

VD4

Installation and service instructions

12 ... 36 kV - 630 ... 3150 A - 16 ... 50 kA

Index

For your safety!	1
I. Introduction	2
II. Environmental protection programme	2
1. Packing and transport	3
2. Checking on receipt	4
3. Storage	5
4. Handling	6
5. Description	7
6. Instructions for operating the circuit-breaker	48
7. Installation	52
8. Putting into service	59
9. Maintenance	61
10. Application of the X-ray emission Standards	65
11. Spare parts and accessories	66
12. Electric circuit diagrams	67
13. Overall dimensions	68
14. Product quality and environmental protection	94



For your safety!

- Make sure that the installation room (spaces, divisions and ambient) is suitable for the electrical apparatus.
- Check that all the installation, putting into service and maintenance operations are carried out by qualified personnel with suitable knowledge of the apparatus.
- Make sure that the standard and legal prescriptions are complied with during installation, putting into service and maintenance, so that installations according to the rules of good working practice and safety in the work place are constructed.
- Strictly follow the information given in this instruction manual.
- Check that the rated performance of the apparatus is not exceeded during service.
- Check that the personnel operating the apparatus have this instruction manual to hand as well as the necessary information for correct intervention.
- Pay special attention to the danger notes indicated in the manual by the following symbol:



Responsible behaviour safeguards
your own and others' safety!
For any requests, please contact the
ABB Assistance Service.

I. Introduction

This publication contains the information needed to install medium voltage VD4 circuit-breakers and put them into service.

For correct use of the product, please read it carefully.

Like all the apparatus we manufacture, the VD4 circuit-breakers are designed for different installation configurations. However, this apparatus allows further technical-construction modifications (at the customer's request) to adapt to special installation requirements.

Consequently, the information given below may sometimes not contain instructions concerning special configurations. Apart from this manual, it is therefore always necessary to consult the latest technical documentation (electric circuit and wiring diagrams, assembly and installation drawings, any protection coordination studies, etc.), especially regarding any variants requested in relation to the standardised configurations.

Only use original spare parts for maintenance operations.

For further information, please also see the technical catalogue of the circuit-breaker and the spare parts catalogue.



All the installation, putting into service, running and maintenance operations must be carried out by skilled personnel with in-depth knowledge of the apparatus.

II. Environmental protection programme

The VD4 circuit-breakers are manufactured in accordance with the ISO 14000 Standards (Guidelines for environmental management).

The production processes are carried out in compliance with the Standards for environmental protection in terms of reduction in energy consumption as well as in raw materials and production of waste materials. All this is thanks to the medium voltage apparatus manufacturing facility environmental management system.

1. Packing and transport

The circuit-breaker is shipped in special packing, in the open position and with the spring discharged.

Each piece of apparatus is protected by a plastic cover to prevent any infiltration of water during the loading and unloading stages and to keep the dust off during storage.

3. Storage

When a period of storage is foreseen, our workshops can (on request) provide suitable packing for the specified storage conditions.

On receipt the apparatus must be carefully unpacked and checked as described in Checking on receipt (chap. 2).

If immediate installation is not possible, the packing must be replaced, using the original material supplied.

Insert packets of special hygroscopic substances inside the packing, with at least one standard packet for piece of apparatus.

Should the original packing not be available and immediate installation is not possible, store in a covered, well-ventilated, dry, dust-free, non-corrosive ambient, away from any easily flammable materials and at a temperature between $-5\text{ }^{\circ}\text{C}$ and $+45\text{ }^{\circ}\text{C}$.

In any case, avoid any accidental impacts or positioning which stresses the structure of the apparatus.

4. Handling

Before carrying out any operations, always make sure that the operating mechanism spring is discharged and that the apparatus is in the open position.

To lift and handle the circuit-breaker, proceed as follows (fig. 2):

- use a special lifting tool (1) (not supplied) fitted with ropes with safety hooks (2);
- insert the hooks (2) in the supports (3) fixed to the frame of the circuit-breaker and lift. Put the hooks (2) into the support holes (3) according to the type of apparatus (see table);
- on completion of the operation (and in any case before putting into service) unhook the lifting tool (1) and dismantle the supports (3) from the frame.

During handling, take great care not to stress the insulating parts and the terminals of the circuit-breaker.

⚠ The apparatus must not be handled by putting lifting devices directly under the apparatus itself. Should it be necessary to use this technique, put the circuit-breaker onto a pallet or a sturdy supporting surface (see fig. 3). In any case, it is always advisable to carry out lifting using the supports (3).

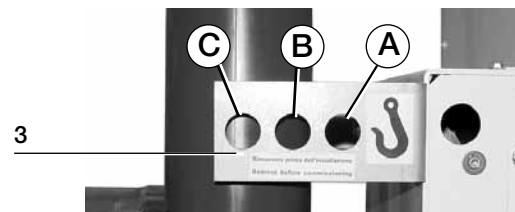
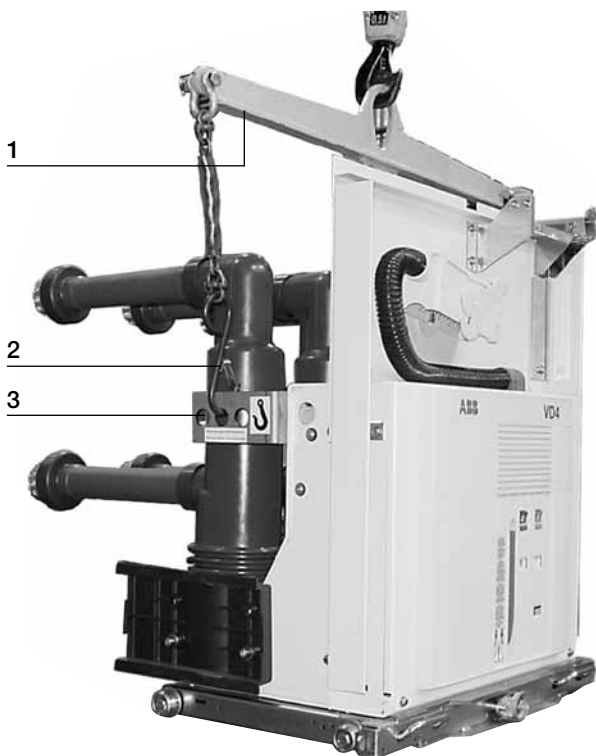

Version	Pole centre distance	Rated current	Hole
Fixed	150-210 mm	up to 1250 A	A
Fixed	275 mm	from 1600 to 3150 A	A
Fixed	210 mm	from 1600 to 2000 A	A
Fixed	210-275 mm	up to 4000 A	C
Withdrawable	150 mm	up to 1250 A	A
Withdrawable	210 mm	from 1600 to 2500 A	B
Withdrawable	275 mm	up to 1250 A	B
Withdrawable	275 mm	from 1600 to 3150 A	C
Withdrawable	210 mm	up to 1250 A	C
Withdrawable	210-275 mm	up to 4000 A	C

Fig. 2

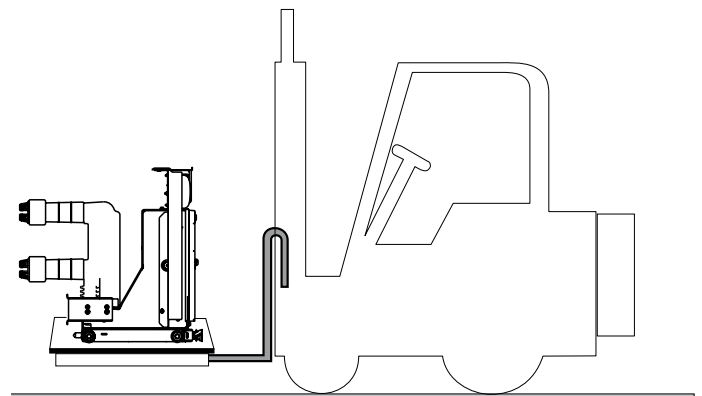

Fig. 3

5. Description

5.1. General

The VD4 are vacuum circuit-breaker for indoor installation. For the electrical performances, please refer to the corresponding technical catalogue code 1VCP000001.

For special installation requirements, please contact ABB.

The following versions are available:

- fixed
- withdrawable for UniGear ZS1 switchgear and PowerCube modules.

5.2. Reference Standards

The VD4 circuit-breakers conform to the IEC 62271-100, CEI - VDE - BS Standards are equivalent to IEC Standards due to harmonization with IEC.

5.3. EL operating mechanism

VD4 circuit-breakers are equipped with modular EL spring operating mechanisms. The operating mechanism is designed to cover the whole range of performances as shown in the following table:

Type of operating mechanism	Rated short-circuit current
EL1 - EL2	Up to 31.5 kA
EL3	Up to 40 kA - 24 kV, 31.5 kA
EL1 TWIN	Up to 50 kA (rated current up to 2000 A)
EL2 TWIN	Up to 50 kA (rated current \geq 2500 A)

5.4. Fixed circuit-breakers

The fixed circuit-breaker (fig. 4) is the basic version complete with structure and front protection screen. The fixing holes are made in the lower part of the structure.

For the electrical connections of the circuit-breaker auxiliary circuits, the terminal box (10) is available (also see par. 7.8.1.). The earthing screw is placed in the rear part of the circuit-breaker. For further details please see the caption to figure 4.

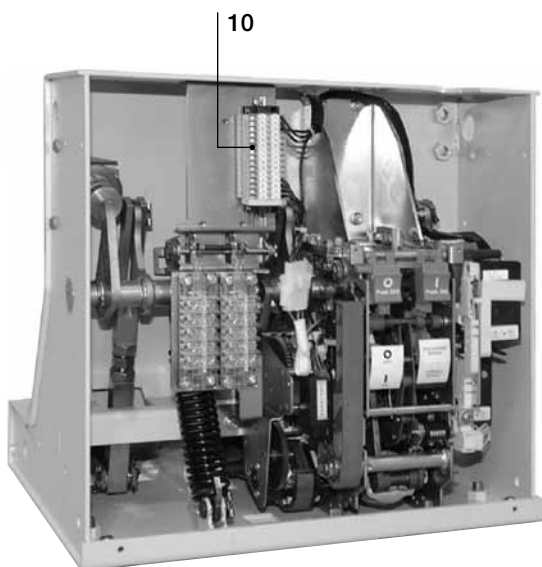
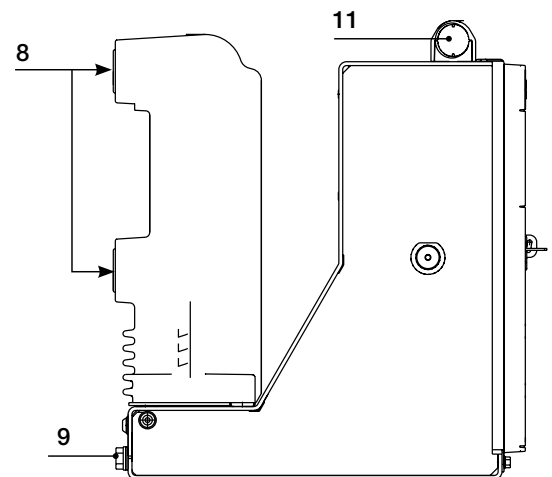
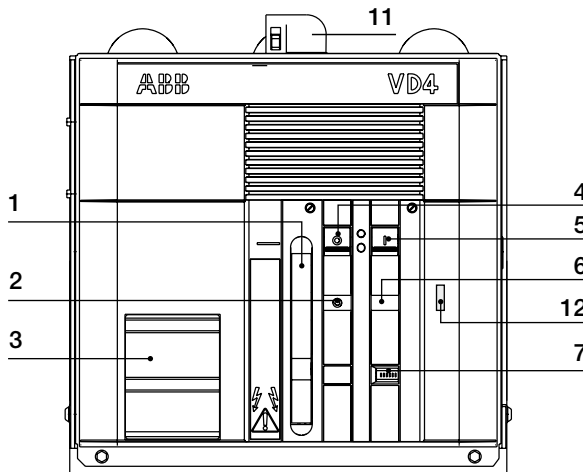

Caption

- 1 Lever for manual closing spring charging
- 2 Signalling device for circuit-breaker open/closed
- 3 Rating plate
- 4 Opening pushbutton
- 5 Closing pushbutton
- 6 Signalling device for closing spring charged/discharged
- 7 Operation counter
- 8 Terminals
- 9 Earthing screw
- 10 Delivery terminal box
- 11 Cabling connection
- 12 Mechanical override of the undervoltage release (on request)

Fig. 4

5.4.1. General characteristics of fixed circuit-breakers

General characteristics of fixed circuit-breakers (12 kV)

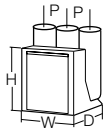

Circuit-breaker	VD4 12											
Standards	IEC 62271-100 • VDE 0671; CEI 17-1 (File 1375) •											
Rated voltage	Ur [kV] 12											
Rated insulation voltage	Us [kV] 12											
Withstand voltage at 50 Hz	Ud (1 min) [kV] 28											
Impulse withstand voltage	Up [kV] 75											
Rated frequency	fr [Hz] 50-60											
Rated normal current (40 °C)	Ir [A]	630	630	630	1250	1250	1250	1250	1250	1250	1250	
		16	16	16	16	16	16	-	-	-	-	
Rated breaking capacity (rated short-circuit breaking current symmetrical)	Isc [kA]	20	20	20	20	20	20	-	-	-	-	
		25	25	25	25	25	25	-	-	-	-	
		31.5	31.5	31.5	31.5	31.5	31.5	-	-	-	-	
		-	-	-	-	-	-	40	40	-	-	
Rated short-time withstand current (3s)	Ik [kA]	-	-	-	-	-	-	-	50	50	-	
		16	16	16	16	16	16	-	-	-	-	
		20	20	20	20	20	20	-	-	-	-	
		25	25	25	25	25	25	-	-	-	-	
Making capacity	Ip [kA]	31.5	31.5	31.5	31.5	31.5	31.5	-	-	-	-	
		-	-	-	-	-	-	40	40	-	-	
		-	-	-	-	-	-	-	-	50	50	
		40	40	40	40	40	40	-	-	-	-	
Operation sequence	[O - 0.3 s - CO - 15 s - CO]	50	50	50	50	50	50	-	-	-	-	
		63	63	63	63	63	63	-	-	-	-	
		80	80	80	80	80	80	-	-	-	-	
		-	-	-	-	-	-	100	100	-	-	
Opening time	[ms]	-	-	-	-	-	-	-	-	125	125	
		33	33	33	33	33	33	-	-	-	-	
		10	10	10	10	10	10	-	-	-	-	
		43	43	43	43	43	43	-	-	-	-	
Arcing time	[ms]	60	60	60	60	60	60	-	-	-	-	
		10	10	10	10	10	10	-	-	-	-	
		43	43	43	43	43	43	-	-	-	-	
		75	75	75	75	75	75	-	-	-	-	
Total breaking time	[ms]	60	60	60	60	60	60	-	-	-	-	
		60	60	60	60	60	60	-	-	-	-	
		60	60	60	60	60	60	-	-	-	-	
		80	80	80	80	80	80	-	-	-	-	
Closing time	[ms]	100	100	100	100	100	100	-	-	-	-	
		125	125	125	125	125	125	-	-	-	-	
		125	125	125	125	125	125	-	-	-	-	
		125	125	125	125	125	125	-	-	-	-	
Maximum overall dimensions		H [mm]	461	461	461	461	461	461	589	589	610	610
		W [mm]	450	570	700	450	570	700	570	700	600	750
		D [mm]	424	424	424	424	424	424	424	424	459	459
		Pole distance P [mm]	150	210	275	150	210	275	210	275	210	275
Weight	[kg]	73	75	79	73	75	79	84	84	146	158	
		73	75	79	73	75	79	84	84	146	158	
Standardised table of dimensions	TN	7405	7406	-	7405	7406	-	-	-	-	-	
		7405	7406	-	7405	7406	-	-	-	-	-	
Operating temperature	[°C]	-5	-5	-5	-5	-5	-5	-5	-5	-5	-5	
		-5	-5	-5	-5	-5	-5	-5	-5	-5	-5	
Tropicalization	IEC: 60068-2-30, 60721-2-1 •											
Electromagnetic compatibility	IEC: 62271-1 •											

•																
•																
12																
12																
28																
75																
50-60																
1600	1600	1600	1600	1600	1600	1600	1600	2000	2000	2000	2000	2500	2500	2500	3150	3150
-	-	-	-	-	-	-	-	-	-	-	-	-	-	-	-	-
20	20	20	-	-	-	-	-	20	20	-	-	20	20	-	20	-
25	25	25	-	-	-	-	-	25	25	-	-	25	25	-	25	-
31.5	31.5	31.5	-	-	-	-	-	31.5	31.5	-	-	31.5	31.5	-	31.5	-
-	-	-	40	40	-	-	-	40	40	-	-	-	40	-	40	-
-	-	-	-	-	50	50	-	-	50	50	-	-	50	-	-	50
-	-	-	-	-	-	-	-	-	-	-	-	-	-	-	-	-
20	20	20	-	-	-	-	-	20	20	-	-	20	20	-	20	-
25	25	25	-	-	-	-	-	25	25	-	-	25	25	-	25	-
31.5	31.5	31.5	-	-	-	-	-	31.5	31.5	-	-	31.5	31.5	-	31.5	-
-	-	-	40	40	-	-	-	40	40	-	-	-	40	-	40	-
-	-	-	-	-	50	50	-	-	50	50	-	-	50	-	-	50
-	-	-	-	-	-	-	-	-	-	-	-	-	-	-	-	-
50	50	50	-	-	-	-	-	50	50	-	-	50	50	-	50	-
63	63	63	-	-	-	-	-	63	63	-	-	63	63	-	63	-
80	80	80	-	-	-	-	-	80	80	-	-	80	80	-	80	-
-	-	-	100	100	-	-	-	100	100	-	-	-	100	-	100	-
-	-	-	-	-	125	125	-	-	125	125	-	-	125	-	125	-
•	•	•	•	•	•	•	•	•	•	•	•	•	•	•	•	-

33 ... 60																
10 ... 15																
43 ... 75																
60 ... 80																
599	599	599	589	589	610	610	599	599	610	610	599	599	610	635	636	
450	570	700	570	700	600	750	570	700	600	750	570	700	750	700	750	
424	424	424	424	424	459	459	424	424	459	459	424	424	459	424	459	
150	210	275	210	275	210	275	210	275	210	275	210	275	275	275	275	
93	98	105	84	84	146	158	98	105	146	158	98	105	163	140	177	
-	7407	7408	-	-	-	-	7407	7408	-	-	7407	7408	-	-	-	
000050	-	-	003282	003285	003440	003441	-	-	003440	003441	-	-	003441	000149	003443	
- 5 ... + 40																

•

•

General characteristics of fixed circuit-breakers (17.5 kV)



Circuit-breaker		VD4 17									
Standards	IEC 62271-100	•									
	VDE 0671; CEI 17-1 (File 1375)	•									
Rated voltage	Ur [kV]	17.5									
Rated insulation voltage	Us [kV]	17.5									
Withstand voltage at 50 Hz	Ud (1 min) [kV]	38									
Impulse withstand voltage	Up [kV]	95									
Rated frequency	fr [Hz]	50-60									
Rated normal current (40 °C)	Ir [A]	630	630	630	1250	1250	1250	1250	1250	1250	1250
		16	16	16	16	16	16	-	-	-	-
Rated breaking capacity (rated short-circuit breaking current symmetrical)	Isc [kA]	20	20	20	20	20	20	-	-	-	-
		25	25	25	25	25	25	-	-	-	-
		31.5	31.5	31.5	31.5	31.5	31.5	-	-	-	-
		-	-	-	-	-	-	40	40	-	-
		-	-	-	-	-	-	-	-	50	50
Rated short-time withstand current (3s)	Ik [kA]	16	16	16	16	16	16	-	-	-	-
		20	20	20	20	20	20	-	-	-	-
		25	25	25	25	25	25	-	-	-	-
		31.5	31.5	31.5	31.5	31.5	31.5	-	-	-	-
		-	-	-	-	-	-	40	40	-	-
Making capacity	Ip [kA]	-	-	-	-	-	-	-	50	50	
		40	40	40	40	40	40	-	-	-	-
		50	50	50	50	50	50	-	-	-	-
		63	63	63	63	63	63	-	-	-	-
		80	80	80	80	80	80	-	-	-	-
Operation sequence	[O - 0.3 s - CO - 15 s - CO]	•	•	•	•	•	•	•	•	•	•
		•	•	•	•	•	•	•	•	•	•
Opening time	[ms]	33 ... 60									
Arcing time	[ms]	10 ... 15									
Total breaking time	[ms]	43 ... 75									
Closing time	[ms]	60 ... 80									
Maximum overall dimensions	H [mm]	461	461	461	461	461	461	589	589	610	610
	W [mm]	450	570	700	450	570	700	570	700	600	750
	D [mm]	424	424	424	424	424	424	424	424	459	459
	Pole distance P [mm]	150	210	275	150	210	275	210	275	210	275
Weight	[kg]	73	75	79	73	75	79	84	84	146	158
Standardised table of dimensions	TN	7405	7406	-	7405	7406	-	-	-	-	-
	1VCD	-	-	000051	-	-	000051	003282	003285	003440	003441
Operating temperature	[°C]	- 5 ... + 40									
Tropicalization	IEC: 60068-2-30, 60721-2-1	•									
Electromagnetic compatibility	IEC: 62271	•									

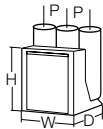

•															
•															
17.5															
17.5															
38															
95															
50-60															
1600	1600	1600	1600	1600	1600	1600	2000	2000	2000	2000	2500	2500	2500	3150	3150
-	-	-	-	-	-	-	-	-	-	-	-	-	-	-	-
20	20	-	-	-	-	-	20	20	-	-	20	20	-	20	-
25	25	-	-	-	-	-	25	25	-	-	25	25	-	25	-
31.5	31.5	-	-	-	-	-	31.5	31.5	-	-	31.5	31.5	-	31.5	-
-	-	40	40	-	-	-	40	40	-	-	-	40	-	40	-
-	-	-	-	50	50	-	-	-	50	50	-	-	50	-	50
-	-	-	-	-	-	-	-	-	-	-	-	-	-	-	-
20	20	-	-	-	-	-	20	20	-	-	20	20	-	20	-
25	25	-	-	-	-	-	25	25	-	-	25	25	-	25	-
31.5	31.5	-	-	-	-	-	31.5	31.5	-	-	31.5	31.5	-	31.5	-
-	-	40	40	-	-	-	40	40	-	-	-	40	-	40	-
-	-	-	-	50	50	-	-	-	50	50	-	-	50	-	50
-	-	-	-	-	-	-	-	-	-	-	-	-	-	-	-
50	50	-	-	-	-	-	50	50	-	-	50	50	-	50	-
63	63	-	-	-	-	-	63	63	-	-	63	63	-	63	-
80	80	-	-	-	-	-	80	80	-	-	80	80	-	80	-
-	-	100	100	-	-	-	100	100	-	-	-	100	-	100	-
-	-	-	-	125	125	-	-	-	125	125	-	-	125	-	125
•	•	•	•	•	•	•	•	•	•	•	•	•	•	•	-
33 ... 60															
10 ... 15															
43 ... 75															
60 ... 80															
599	599	589	589	610	610	599	599	610	610	599	599	610	635	636	
570	700	570	700	600	750	570	700	600	750	570	700	750	700	750	
424	424	424	424	459	459	424	424	459	459	424	424	459	424	459	
210	275	210	275	210	275	210	275	210	275	210	275	275	275	275	
98	105	84	84	146	158	98	105	146	158	98	105	163	140	177	
7407	7408	-	-	-	-	7407	7408	-	-	7407	7408	-	-	-	
-	-	003282	003285	003440	003441	-	-	003440	003441	-	-	003441	000149	003443	
- 5 ... + 40															
•															
•															

General characteristics of fixed circuit-breakers (24 kV)



Circuit-breaker	VD4 24							
Standards	IEC 62271-100 • VDE 0671; CEI 17-1 (File 1375) •							
Rated voltage	Ur [kV]	24						
Rated insulation voltage	Us [kV]	24						
Withstand voltage at 50 Hz	Ud (1 min) [kV]	50						
Impulse withstand voltage	Up [kV]	125						
Rated frequency	fr [Hz]	50-60						
Rated normal current (40 °C)	Ir [A]	630	630	1250	1250	1600	2000	2500
		16	16	16	16	16	16	–
Rated breaking capacity (rated short-circuit breaking current symmetrical)	Isc [kA]	20	20	20	20	20	20	–
		25	25	25	25	25	25	25
		–	–	31.5	–	31.5	31.5	31.5
Rated short-time withstand current (3s)	Ik [kA]	16	16	16	16	16	16	–
		20	20	20	20	20	20	–
		25	25	25	25	25	25	25
Making capacity	Ip [kA]	–	–	31.5	–	31.5	31.5	31.5
		40	40	40	40	40	40	–
		50	50	50	50	50	50	–
Operation sequence	[O - 0.3 s - CO - 15 s - CO]	63	63	63	63	63	63	63
		–	–	80	–	80	80	80
Opening time	[ms]	33 ... 60						
Arcing time	[ms]	10 ... 15						
Total breaking time	[ms]	43 ... 75						
Closing time	[ms]	60 ... 80						
Maximum overall dimensions	H [mm]	631	631	631	631	642	642	642
	W [mm]	570	700	570	700	700	700	700
	D [mm]	424	424	424	424	424	424	424
	Pole distance P [mm]	210	275	210	275	275	275	275
Weight	[kg]	100	104	100/106 ⁽¹⁾	104	110	110	110
	TN	7409	7410	7409	7410	7411	7411	7411
Standardised table of dimensions	1VCD	–	–	000172 ⁽¹⁾	–	–	–	–
Operating temperature	[°C]	- 5 ... + 40						
Tropicalization	IEC: 60068-2-30, 60721-2-1	•						
Electromagnetic compatibility	IEC: 62271-1	•						

(1) 31.5 kA version.

General characteristics of fixed circuit-breakers (36 kV)

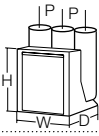

Circuit-breaker	VD4 36					
Standards	IEC 62271-100	•				
	VDE 0671; CEI 17-1 (File 1375)	•				
Rated voltage	Ur [kV]	36				
Rated insulation voltage	Us [kV]	36				
Withstand voltage at 50 Hz	Ud (1 min) [kV]	70				
Impulse withstand voltage	Up [kV]	170				
Rated frequency	fr [Hz]	50-60				
Rated normal current (40 °C)	Ir [A]	1250	1600	2000	2500 (*)	
Rated breaking capacity (rated short-circuit breaking current symmetrical)	Isc [kA]	31.5	31.5	31.5	31.5	
		–	–	–	–	
		–	–	–	–	
Rated short-time withstand current (3s)	Ik [kA]	31.5	31.5	31.5	31.5	
		–	–	–	–	
		–	–	–	–	
Making capacity	Ip [kA]	80	80	80	80	
		–	–	–	–	
		–	–	–	–	
Operation sequence	[O - 0.3 s - CO - 15 s - CO]	•	•	•	•	
Opening time	[ms]	35 ... 60				
Arcing time	[ms]	10 ... 15				
Total breaking time	[ms]	45 ... 75				
Closing time	[ms]	60 ... 80				
Maximum overall dimensions		H [mm]	564	564	564	–
		W [mm]	778	778	778	–
		D [mm]	468	468	468	–
		Pole distance P [mm]	275	275	275	–
Weight	[kg]	150	150	170	–	
Standardised table of dimensions	TN	1VYN300901-LT	1VYN300901-LT	1VYN300901-LT	–	
Operating temperature	[°C]	- 5 ... + 40				
Tropicalization	IEC: 60068-2-30, 60721-2-1	•				
Electromagnetic compatibility	IEC: 62271-1	•				

(*) Contact ABB

5.4.2. Types of circuit-breakers available in the fixed version

VD4 fixed circuit-breaker without bottom and top terminals (12 kV)

Ur	Isc	Rated uninterrupted current (40°C) [A]											Circuit-breaker type	
		H=461			H=589			H=599			H=610			H=636
kV	kA	D=424			D=424			D=424			D=459		D=459	
		u/l=205			u/l=310			u/l=310			u/l=310		u/l=310	
		I/g=217.5			I/g=238			I/g=237.5			I/g=237		I/g=237	
		P=150	P=210	P=275	P=210	P=275	P=150	P=210	P=275	P=210	P=275	P=275		
		W=450	W=570	W=700	W=570	W=700	W=450	W=570	W=700	W=600	W=750	W=750		
12	16	630											VD4 12.06.16 p150	
	20	630											VD4 12.06.20 p150	
	25	630											VD4 12.06.25 p150	
	31.5	630											VD4 12.06.32 p150	
	16	1250											VD4 12.12.16 p150	
	20	1250											VD4 12.12.20 p150	
	25	1250											VD4 12.12.25 p150	
	31.5	1250											VD4 12.12.32 p150	
	20							1600						VD4 12.16.20 p150
	25							1600						VD4 12.16.25 p150
	31.5							1600						VD4 12.16.32 p150
	16	630												VD4 12.06.16 p210
	20	630												VD4 12.06.20 p210
	25	630												VD4 12.06.25 p210
	31.5	630												VD4 12.06.32 p210
	16	1250												VD4 12.12.16 p210
	20	1250												VD4 12.12.20 p210
	25	1250												VD4 12.12.25 p210
	31.5	1250												VD4 12.12.32 p210
	40					1250								VD4 12.12.40 p210
	50							1250						VD4 12.12.50 p210
	20							1600						VD4 12.16.20 p210
	25							1600						VD4 12.16.25 p210
	31.5							1600						VD4 12.16.32 p210
	40					1600								VD4 12.16.40 p210
	50							1600						VD4 12.16.50 p210
	20							2000						VD4 12.20.20 p210
	25							2000						VD4 12.20.25 p210
	31.5							2000						VD4 12.20.32 p210
	40							2000						VD4 12.20.40 p210
	50							2000						VD4 12.20.50 p210
20							2500						VD4 12.25.20 p210	
25							2500						VD4 12.25.25 p210	
31.5							2500						VD4 12.25.32 p210	
16				630									VD4 12.06.16 p275	
20				630									VD4 12.06.20 p275	
25				630									VD4 12.06.25 p275	
31.5				630									VD4 12.06.32 p275	
16				1250									VD4 12.12.16 p275	
20				1250									VD4 12.12.20 p275	
25				1250									VD4 12.12.25 p275	
31.5				1250									VD4 12.12.32 p275	
40					1250								VD4 12.12.40 p275	
50							1250						VD4 12.12.50 p275	

H = Height of the circuit-breaker.

W = Width of the circuit-breaker.

D = Depth of the circuit-breaker.

u/l = Distance between bottom and top terminal.

I/g = Distance between the bottom terminal and the resting surface of the circuit-breaker.

P = Pole horizontal centre distance.

Ur	Isc	Rated uninterrupted current (40 °C) [A]											Circuit-breaker type
		H=461			H=589		H=599		H=610		H=636		
kV	kA	D=424			D=424		D=424		D=459		D=459		
		u/l=205			u/l=310		u/l=310		u/l=310		u/l=310		
		l/g=217.5			l/g=238		l/g=237.5		l/g=237		l/g=237		
		P=150	P=210	P=275	P=210	P=275	P=150	P=210	P=275	P=210	P=275	P=275	
		W=450	W=570	W=700	W=570	W=700	W=450	W=570	W=700	W=600	W=750	W=750	
12	20									1600			VD4 12.16.20 p275
	25									1600			VD4 12.16.25 p275
	31.5									1600			VD4 12.16.32 p275
	40					1600							VD4 12.16.40 p275
	50										1600		VD4 12.16.50 p275
	20									2000			VD4 12.20.20 p275
	25									2000			VD4 12.20.25 p275
	31.5									2000			VD4 12.20.32 p275
	40									2000			VD4 12.20.40 p275
	50										2000		VD4 12.20.50 p275
	20									2500			VD4 12.25.20 p275
	25									2500			VD4 12.25.25 p275
	31.5									2500			VD4 12.25.32 p275
	40									2500			VD4 12.25.40 p275
	50										2500		VD4 12.25.50 p275
	20											3150	VD4 12.32.20 p275
	25											3150	VD4 12.32.25 p275
	31.5											3150	VD4 12.32.32 p275
	40											3150	VD4 12.32.40 p275
	50											3150	VD4 12.32.50 p275

- H = Height of the circuit-breaker.
- W = Width of the circuit-breaker.
- D = Depth of the circuit-breaker.
- u/l = Distance between bottom and top terminal.
- l/g = Distance between the bottom terminal and the resting surface of the circuit-breaker.
- P = Pole horizontal centre distance.

VD4 fixed circuit-breaker without bottom and top terminals (17.5 kV)

Ur	Isc	Rated uninterrupted current (40 °C) [A]											Circuit-breaker type
		H=461			H=589		H=599		H=610		H=635		
kV	kA	D=424			D=424		D=424		D=459		D=459		
		u/l=205			u/l=310		u/l=310		u/l=310		u/l=310		
		l/g=217.5			l/g=238		l/g=237.5		l/g=237		l/g=237.5		
		P=150	P=210	P=275	P=210	P=275	P=150	P=210	P=275	P=210	P=275	P=275	
		W=450	W=570	W=700	W=570	W=700	W=450	W=570	W=700	W=600	W=750	W=750	
17.5	16												VD4 17.06.16 p150
	20												VD4 17.06.20 p150
	25												VD4 17.06.25 p150
	31.5												VD4 17.06.32 p150
	16												VD4 17.12.16 p150
	20												VD4 17.12.20 p150
	25												VD4 17.12.25 p150
	31.5												VD4 17.12.32 p150
	20							1600					VD4 17.16.20 p150
	25							1600					VD4 17.16.25 p150
	31.5							1600					VD4 17.16.32 p150
	16			630									VD4 17.06.16 p210
	20			630									VD4 17.06.20 p210
	25			630									VD4 17.06.25 p210
	31.5			630									VD4 17.06.32 p210

Ur	Isc	Rated uninterrupted current (40 °C) [A]											Circuit-breaker type	
		H=461			H=589			H=599			H=610			H=635
kV	kA	D=424			D=424			D=424			D=459		D=459	
		u/l=205			u/l=310			u/l=310			u/l=310		u/l=310	
		l/g=217.5			l/g=238			l/g=237.5			l/g=237		l/g=237.5	
		P=150	P=210	P=275	P=210	P=275	P=150	P=210	P=275	P=210	P=275	P=275	P=275	
	W=450	W=570	W=700	W=570	W=700	W=450	W=570	W=700	W=600	W=750	W=750			
17.5	16		1250										VD4 17.12.16 p210	
	20		1250										VD4 17.12.20 p210	
	25		1250										VD4 17.12.25 p210	
	31.5		1250										VD4 17.12.32 p210	
	40				1250								VD4 17.12.40 p210	
	50									1250			VD4 17.12.50 p210	
	20								1600				VD4 17.16.20 p210	
	25								1600				VD4 17.16.25 p210	
	31.5								1600				VD4 17.16.32 p210	
	40				1600								VD4 17.16.40 p210	
	50									1600			VD4 17.16.50 p210	
	20								2000				VD4 17.20.20 p210	
	25								2000				VD4 17.20.25 p210	
	31.5								2000				VD4 17.20.32 p210	
	40								2000				VD4 17.20.40 p210	
50									2000			VD4 17.20.50 p210		
20								2500				VD4 17.25.20 p210		
25								2500				VD4 17.25.25 p210		
31.5								2500				VD4 17.25.32 p210		
16			630									VD4 17.06.16 p275		
20			630									VD4 17.06.20 p275		
25			630									VD4 17.06.25 p275		
31.5			630									VD4 17.06.32 p275		
16			1250									VD4 17.12.16 p275		
20			1250									VD4 17.12.20 p275		
25			1250									VD4 17.12.25 p275		
31.5			1250									VD4 17.12.32 p275		
40					1250							VD4 17.12.40 p275		
50										1250		VD4 17.12.50 p275		
20									1600			VD4 17.16.20 p275		
25									1600			VD4 17.16.25 p275		
31.5									1600			VD4 17.16.32 p275		
40					1600							VD4 17.16.40 p275		
50										1600		VD4 17.16.50 p275		
20									2000			VD4 17.20.20 p275		
25									2000			VD4 17.20.25 p275		
31.5									2000			VD4 17.20.32 p275		
40									2000			VD4 17.20.40 p275		
50										2000		VD4 17.20.50 p275		
20									2500			VD4 17.25.20 p275		
25									2500			VD4 17.25.25 p275		
31.5									2500			VD4 17.25.32 p275		
40									2500			VD4 17.25.40 p275		
50										2500		VD4 17.25.50 p275		
20											3150	VD4 17.32.20 p275		
25											3150	VD4 17.32.25 p275		
31.5											3150	VD4 17.32.32 p275		
40											3150	VD4 17.32.40 p275		
50											3150	VD4 17.32.50 p275		

H = Height of the circuit-breaker.

W = Width of the circuit-breaker.

D = Depth of the circuit-breaker.

u/l = Distance between bottom and top terminal.

l/g = Distance between the bottom terminal and the resting surface of the circuit-breaker.

P = Pole horizontal centre distance.

VD4 fixed circuit-breaker without bottom and top terminals (24 kV)

Ur	Isc	Rated uninterrupted current (40 °C) [A]				Circuit-breaker type
		H=631	H=642	H=631	H=642	
kV	kA	D=424	D=424	D=424	D=424	
		u/l=310	u/l=310	u/l=310	u/l=310	
		l/g=282.5	l/g=282.5	l/g=282.5	l/g=282.5	
		P=210	P=275	P=275	P=275	
		W=570	W=700	W=700	W=700	
24	16	630				VD4 24.06.16 p210
	20	630				VD4 24.06.20 p210
	25	630				VD4 24.06.25 p210
	16	1250				VD4 24.12.16 p210
	20	1250				VD4 24.12.20 p210
	25	1250				VD4 24.12.25 p210
	31.5	1250				VD4 24.12.32 p210
	16		630			VD4 24.06.16 p275
	20		630			VD4 24.06.20 p275
	25		630			VD4 24.06.25 p275
	16		1250			VD4 24.12.16 p275
	20		1250			VD4 24.12.20 p275
	25		1250			VD4 24.12.25 p275
	16			1600		VD4 24.16.16 p275
	20			1600		VD4 24.16.20 p275
	25			1600		VD4 24.16.25 p275
	31.5			1600		VD4 24.16.32 p275
	16			2000		VD4 24.20.16 p275
	20			2000		VD4 24.20.20 p275
	25			2000		VD4 24.20.25 p275
31.5			2000		VD4 24.20.32 p275	
25			2500		VD4 24.25.25 p275	
31.5			2500		VD4 24.25.32 p275	

H = Height of the circuit-breaker.
W = Width of the circuit-breaker.
D = Depth of the circuit-breaker.
u/l = Distance between bottom and top terminal.
l/g = Distance between the bottom terminal and the resting surface of the circuit-breaker.
P = Pole horizontal centre distance.

VD4 fixed circuit-breaker without bottom and top terminals (36 kV)

Ur	Isc	Rated uninterrupted current (40 °C) [A]				Circuit-breaker type
		H=564	H=564	H=564	H=564	
kV	kA	D=468	D=468	D=468	D=468	
		u/l=380	u/l=380	u/l=380	u/l=380	
		l/g=399	l/g=399	l/g=399	l/g=399	
		P=275	P=275	P=275	P=275	
		W=778	W=778	W=778	W=778	
36	31.5	1250 A				VD4 36.12.32 p275
			1600 A			VD4 36.16.32 p275
				2000 A		VD4 36.20.32 p275
					2500 A (*)	VD4 36.25.32 p275

H = Height of the circuit-breaker.
W = Width of the circuit-breaker.
D = Depth of the circuit-breaker.
u/l = Distance between bottom and top terminal.
l/g = Distance between the bottom terminal and the resting surface of the circuit-breaker.
P = Pole horizontal centre distance.
(*) = To be released. Contact ABB.



VD4 – up to 24 kV



VD4 – up to 24 kV



VD4 - 36 kV

5.4.3. Standard fittings for fixed circuit-breakers

The basic versions of the fixed circuit-breakers are three-pole and fitted with:

- EL type manual operating mechanism
- mechanical signalling device for closing spring charged/ discharged
- mechanical signalling device for circuit-breaker open/closed
- closing pushbutton, opening pushbutton and operation counter

- set of ten circuit-breaker open/closed auxiliary contacts
 Note: with the set of ten auxiliary contacts supplied as standard and the maximum number of electrical applications possible, three make contacts (signalling circuit-breaker open) and five break contacts (signalling circuit-breaker closed) are available.
- lever for manual closing spring charging
- auxiliary circuit support terminal box.

5.5. Withdrawable circuit-breakers

The withdrawable circuit-breakers up to 24 kV are available for UniGear ZS1 and UniSec switchgear, PowerCube modules (see fig. 5a) and for ZS8.4 switchgear (see fig. 5b).

The 36 kV circuit-breakers are available for ZS2 switchgear. They consist of a truck on which the supporting structure of the circuit-breaker is fixed.

Circuit-breakers for UniGear ZS1 and UniSec switchgear and for PowerCube modules (fig. 5a)

The cord with the connector (14) (plug) for connection of the operating mechanism electrical accessories comes out of the connection (15).

The strikers for operating the contacts (connected/isolated) placed in the switchgear are fixed in the top part of the circuit-breaker.

The shutter actuator (9) (roller (18) for UniSec version) are provided for operating the segregation shutters of the medium voltage contacts of the enclosure or of the switchgear are fixed on the sides of the circuit-breaker.

The crosspiece with the handles (17) for hooking up the circuit-breaker for the racking-in/out operations by means of the special operating lever (16) is mounted on the front part of the circuit-breaker truck.

The circuit-breaker is completed with the isolating contacts (8). The withdrawable circuit-breaker is fitted with special locks on the front crosspiece, which allow hooking up into the

corresponding couplings of the switchgear.

The locks can only be activated by the handles with the truck fully resting against the crosspiece.

The operating lever (16) must be fully inserted (also see par. 7.5.). A lock prevents the truck from advancing into the enclosure or fixed part when the earthing switch is closed. Another lock prevents racking-in and racking-out with the circuit-breaker closed. With the truck in an intermediate position between isolated and connected, a further lock prevents circuit-breaker closing (either mechanical or electrical).

A locking magnet is also mounted on the truck which, when de-energised, prevents the truck racking-in operation.

On request, an interlock is available which prevents racking-in of the circuit-breaker with the door open, and door opening with the circuit-breaker closed.

The lever for loading the closing spring (1) in the manual mode is built into the operating mechanism. The spring is loaded by repeatedly lowering the lever with linear movements until the yellow indicator (6) appears to show that loading is complete. The spring can only be loaded with the switchgear door open. Comply with the instructions in the UniGear switchgear manual for the operations that can be performed with the door open.

Note: on request, the closing spring loading device for withdrawable circuit-breakers for UniGear switchgear can be supplied with the lever outside the operating mechanism and a rotary loading movement. This device is part of the standard equipment for VD4/ZS8 withdrawable circuit-breakers only (see detail 1 of Fig. 5b on the next page). This rotary loading device allows the closing spring to be loaded with the switchgear door closed.

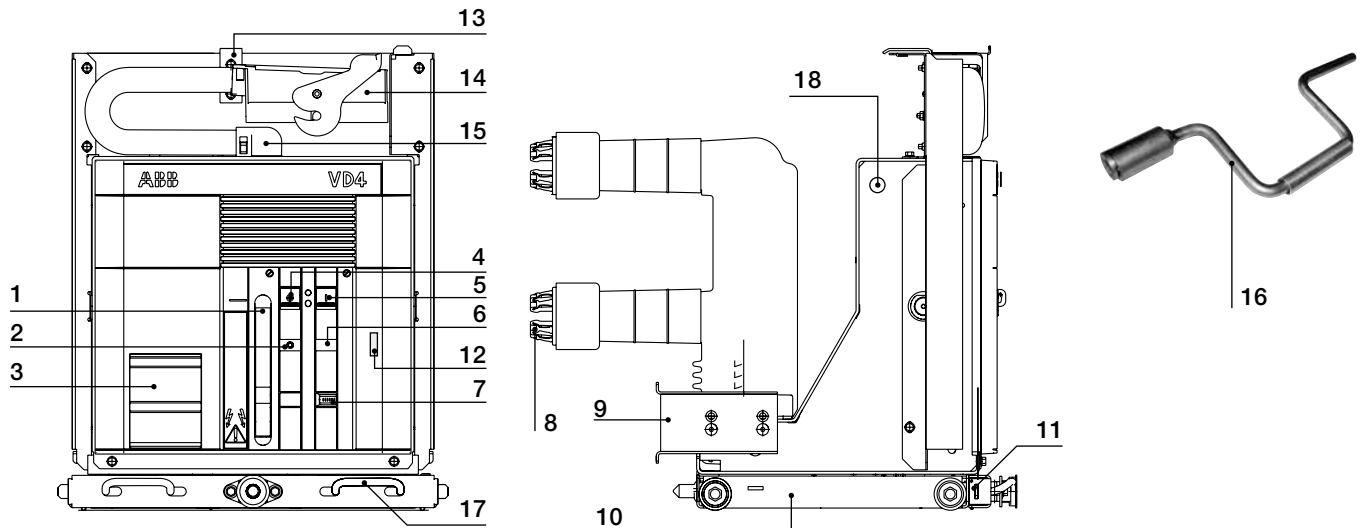

Caption

- 1 Lever for manually charging the closing spring
- 2 Signalling device for circuit-breaker open/closed
- 3 Rating plate
- 4 Opening pushbutton
- 5 Closing pushbutton
- 6 Signalling device for closing spring charged/discharged
- 7 Operation counter
- 8 Isolating contacts

- 9 Slide for operating the switchgear shutters (UniGear ZS1, PowerCube, ZS8.4)
- 10 Truck
- 11 Locks for hooking into the fixed part
- 12 Mechanical override of the undervoltage release (on request)
- 13 Strikers for activating the contacts placed in the enclosure
- 14 Connector (plug)
- 15 Cabling connection
- 16 Operating lever for circuit-breaker racking-in/out
- 17 Handles for activating the locks (11)
- 18 Shutter actuator (for UniSec version only)

Fig. 5a

Circuit-breakers for ZS8.4 switchgear (fig. 5b)

The socket (13) takes the connector (plug) placed in the switchgear.

The slides (9) for operating the segregation shutters of the medium voltage contacts of the switchgear are fixed on the sides of the circuit-breaker.

The crosspiece with the handles (17) for hooking up the circuit-breaker for the racking-in/out operations by means of the special operating lever (16) is mounted on the front part of the circuit-breaker truck.

The circuit-breaker is completed with the isolating contacts (8). The withdrawable circuit-breaker is fitted with special locks, described below (see fig. 5c - 5d).

1) Prevention of traverse with circuit-breaker closed

With the circuit-breaker closed, the feeler pin (16 - fig. 5c) prevents the shutter sliding (19 - fig. 5c) and therefore insertion of the lever (20 - fig. 5c) for traverse of the apparatus.

2) Prevention of traverse with socket-plug disconnected

When the plug is not inserted in the socket (13), the stem (21 - fig. 5c) prevents the plate (22 - fig. 5c) lifting and traverse of the apparatus.

3) Prevention of switchgear door closing with socket-plug disconnected (*)

When the plug is not inserted in the socket (13), the feeler pin (23 - fig. 5d) prevents door closing.

4) Prevention of circuit-breaker racking-out with the socket-plug connected (*)

When the plug is inserted in the socket (13), the lock bolt (29 - fig. 5d) hits the pin (30 - fig. 5d) preventing the apparatus from being racked out of the switchgear.

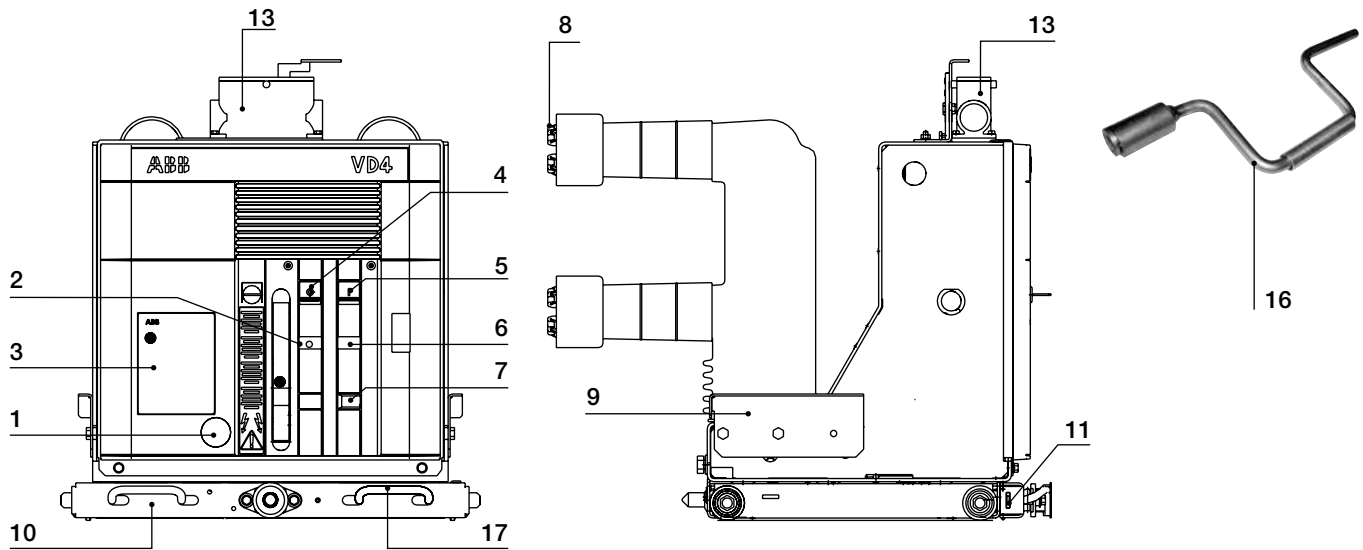

Caption

- 1 Coupling for the manual closing spring charging lever (*)
- 2 Signalling device for circuit-breaker open/closed
- 3 Rating plate
- 4 Opening pushbutton
- 5 Closing pushbutton
- 6 Signalling device for closing spring charged/discharged
- 7 Operation counter
- 8 Isolating contacts

- 9 Slide for operating the switchgear shutters
- 10 Truck
- 11 Locks for hooking into the fixed part
- 13 Connector (plug)
- 16 Operating lever for circuit-breaker racking-in/out (a special version is provided for VD4/ZS8 Preussen Elektra EON circuit-breakers)
- 17 Handles for activating the locks (11)

(*) Only VD4/ZS8 Preussen - Elektra EON version.

Fig. 5b

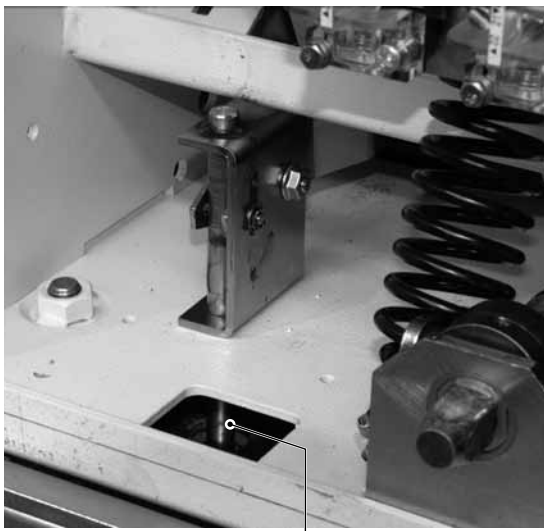

16



19

20

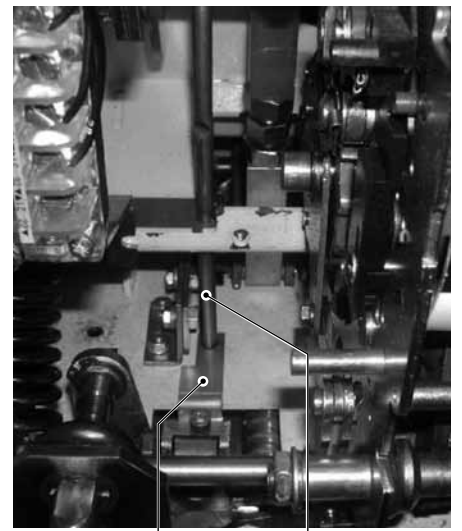

22

21

Fig. 5c



23



30

29

Fig. 5d

5.5.1. General characteristics of withdrawable circuit-breakers for UniGear ZS1 switchgear

General characteristics of withdrawable circuit-breakers for UniGear ZS1 switchgear (12 kV)



Circuit-breaker	VD4/P 12								
Standards	IEC 62271-100 • VDE 0671; CEI 17-1 (File 1375) •								
Rated voltage	Ur [kV]	12							
Rated insulation voltage	Us [kV]	12							
Withstand voltage at 50 Hz	Ud (1 min) [kV]	28							
Impulse withstand voltage	Up [kV]	75							
Rated frequency	fr [Hz]	50-60							
Rated normal current (40 °C) ⁽¹⁾	Ir [A]	630	1250	1250	1250	1250	1600	1600	
		16	16	–	–	–	–	–	
Rated breaking capacity (rated short-circuit breaking current symmetrical)	Isc [kA]	20	20	–	–	–	20	20	
		25	25	–	–	–	25	25	
		31.5	31.5	–	–	–	31.5	31.5	
		–	–	40	40	–	–	–	
		–	–	–	–	50	–	–	
		–	–	–	–	–	–	–	
Rated short-time withstand current (3s)	Ik [kA]	16	16	–	–	–	–	–	
		20	20	–	–	–	20	20	
		25	25	–	–	–	25	25	
		31.5	31.5	–	–	–	31.5	31.5	
		–	–	40	40	–	–	–	
		–	–	–	–	50	–	–	
Making capacity	Ip [kA]	40	40	–	–	–	–	–	
		50	50	–	–	–	50	50	
		63	63	–	–	–	63	63	
		80	80	–	–	–	80	80	
		–	–	100	100	–	–	–	
		–	–	–	–	125	–	–	
Operation sequence	[O - 0.3 s - CO - 15 s - CO]	•	•	•	•	•	•	•	
Opening time	[ms]	33 ... 60							
Arcing time	[ms]	10 ... 15							
Total breaking time	[ms]	43 ... 75							
Closing time	[ms]	60 ... 80							
Maximum overall dimensions		H [mm]	628	628	691	691	691	691	691
		W [mm]	503	503	653	853	681	653	853
		D [mm]	662	662	641	642	643	642	642
		Pole distance P [mm]	150	150	210	275	210	210	275
Weight	[kg]	116	116	174	176	180	160	166	
Standardised table of dimensions	TN	7412	7412	–	–	–	7415	7416	
	1VCD	–	–	003284	003286	003444	–	–	
Operating temperature	[°C]	- 5 ... + 40							
Tropicalization	IEC: 60068-2-30, 60721-2-1	•							
Electromagnetic compatibility	IEC: 62271-1	•							

(1) Rated current guaranteed with circuit-breaker installed in UniGear ZS1 switchgear and with 40 °C ambient temperature.

(2) Up to 4000 A with forced ventilation. Available on request.

•												
•												
12												
12												
28												
75												
50-60												
1600	1600	1600	1600	2000	2000	2000	2000	2500	2500	3150 ⁽²⁾	3150 ⁽²⁾	
-	-	-	-	-	-	-	-	-	-	-	-	-
-	-	-	-	20	20	-	-	20	-	20	-	-
-	-	-	-	25	25	-	-	25	-	25	-	-
-	-	-	-	31.5	31.5	-	-	31.5	-	31.5	-	-
40	40	-	-	40	40	-	-	40	-	40	-	-
-	-	50	50	-	-	50	50	-	50	-	50	-
-	-	-	-	-	-	-	-	-	-	-	-	-
-	-	-	-	20	20	-	-	20	-	20	-	-
-	-	-	-	25	25	-	-	25	-	25	-	-
-	-	-	-	31.5	31.5	-	-	31.5	-	31.5	-	-
40	40	-	-	40	40	-	-	40	-	40	-	-
-	-	50	50	-	-	50	50	-	50	-	50	-
-	-	-	-	-	-	-	-	-	-	-	-	-
-	-	-	-	50	50	-	-	50	-	50	-	-
-	-	-	-	63	63	-	-	63	-	63	-	-
-	-	-	-	80	80	-	-	80	-	80	-	-
100	100	-	-	100	100	-	-	100	-	100	-	-
-	-	125	125	-	-	125	125	-	125	-	125	-
•	•	•	•	•	•	•	•	•	•	•	•	•
33 ... 60												
10 ... 15												
43 ... 75												
60 ... 80												
691	691	691	691	691	691	691	691	691	691	730	742	
653	853	681	853	653	853	681	853	853	853	853	853	
641	642	643	643	642	642	643	643	640	643	640	643	
210	275	210	275	210	275	210	275	275	275	275	275	
174	176	180	193	160	166	190	205	186	225	221	240	
-	-	-	-	7415	7416	-	-	7417	-	-	-	
003284	003286	003444	003445	-	-	003444	003445	-	003446	000153	003447	
- 5 ... + 40												
•												
•												

General characteristics of withdrawable circuit-breakers for UniGear ZS1 switchgear (17.5 kV)

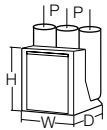

Circuit-breaker		VD4/P 17							
Standards	IEC 62271-100 • VDE 0671; CEI 17-1 (File 1375) •								
Rated voltage	Ur [kV]	17.5							
Rated insulation voltage	Us [kV]	17.5							
Withstand voltage at 50 Hz	Ud (1 min) [kV]	38							
Impulse withstand voltage	Up [kV]	95							
Rated frequency	fr [Hz]	50-60							
Rated normal current (40 °C) ⁽¹⁾	Ir [A]	630	1250	1250	1250	1250	1600	1600	
		16	16	–	–	–	–	–	
Rated breaking capacity (rated short-circuit breaking current symmetrical)	Isc [kA]	20	20	–	–	–	20	20	
		25	25	–	–	–	25	25	
		31.5	31.5	–	–	–	31.5	31.5	
		–	–	40	40	–	–	–	
		–	–	–	–	50	–	–	
Rated short-time withstand current (3s)	Ik [kA]	16	16	–	–	–	–	–	
		20	20	–	–	–	20	20	
		25	25	–	–	–	25	25	
		31.5	31.5	–	–	–	31.5	31.5	
		–	–	40	40	–	–	–	
Making capacity	Ip [kA]	–	–	–	–	50	–	–	
		40	40	–	–	–	–	–	
		50	50	–	–	–	50	50	
		63	63	–	–	–	63	63	
		80	80	–	–	–	80	80	
Operation sequence	[O - 0.3 s - CO - 15 s - CO]	•	•	•	•	•	•	•	
		•	•	•	•	•	•	•	
Opening time	[ms]	33 ... 60							
Arcing time	[ms]	10 ... 15							
Total breaking time	[ms]	43 ... 75							
Closing time	[ms]	60 ... 80							
Maximum overall dimensions		H [mm]	632	632	691	691	691	691	691
		W [mm]	503	503	653	853	681	653	853
		D [mm]	664	664	641	642	643	642	642
		Pole distance P [mm]	150	150	210	275	210	210	275
Weight	[kg]	116	116	174	176	180	160	166	
Standardised table of dimensions	TN	7412	7412	–	–	–	7415	7416	
	1VCD	–	–	003284	003286	003444	–	–	
Operating temperature	[°C]	– 5 ... + 40							
Tropicalization	IEC: 60068-2-30, 60721-2-1	•							
Electromagnetic compatibility	IEC: 62271-1	•							

(1) Rated current guaranteed with circuit-breaker installed in UniGear ZS1 switchgear and with 40 °C ambient temperature.

(2) Up to 4000 A with forced ventilation. Available on request.

•												
•												
17.5												
17.5												
38												
95												
50-60												
1600	1600	1600	1600	2000	2000	2000	2000	2500	2500	3150 ⁽²⁾	3150 ⁽²⁾	
-	-	-	-	-	-	-	-	-	-	-	-	-
-	-	-	-	20	20	-	-	20	-	20	-	-
-	-	-	-	25	25	-	-	25	-	25	-	-
-	-	-	-	31.5	31.5	-	-	31.5	-	31.5	-	-
40	40	-	-	40	40	-	-	40	-	40	-	-
-	-	50	50	-	-	50	50	-	50	-	50	-
-	-	-	-	-	-	-	-	-	-	-	-	-
-	-	-	-	20	20	-	-	20	-	20	-	-
-	-	-	-	25	25	-	-	25	-	25	-	-
-	-	-	-	31.5	31.5	-	-	31.5	-	31.5	-	-
40	40	-	-	40	40	-	-	40	-	40	-	-
-	-	50	50	-	-	50	50	-	50	-	50	-
-	-	-	-	-	-	-	-	-	-	-	-	-
-	-	-	-	50	50	-	-	50	-	50	-	-
-	-	-	-	63	63	-	-	63	-	63	-	-
-	-	-	-	80	80	-	-	80	-	80	-	-
100	100	-	-	100	100	-	-	100	-	100	-	-
-	-	125	125	-	-	125	125	-	125	-	125	-
•	•	•	•	•	•	•	•	•	•	•	•	•
33 ... 60												
10 ... 15												
43 ... 75												
60 ... 80												
691	691	691	691	691	691	691	691	691	691	730	742	
653	853	681	853	653	853	681	853	853	853	853	853	
641	642	643	643	642	642	643	643	640	643	640	643	
210	275	210	275	210	275	210	275	275	275	275	275	
174	176	180	193	160	166	190	205	186	225	221	240	
-	-	-	-	7415	7416	-	-	7417	-	-	-	
003284	003286	003444	003445	-	-	003444	003445	-	003446	000153	003447	
- 5 ... + 40												
•												
•												

General characteristics of withdrawable circuit-breakers for UniGear ZS1 switchgear (24 kV)

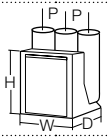

Circuit-breaker		VD4/P 24									
Standards	IEC 62271-100 • VDE 0671; CEI 17-1 (File 1375) •										
Rated voltage	Ur [kV]	24									
Rated insulation voltage	Us [kV]	24									
Withstand voltage at 50 Hz	Ud (1 min) [kV]	50									
Impulse withstand voltage	Up [kV]	125									
Rated frequency	fr [Hz]	50-60									
Rated normal current (40 °C) ⁽¹⁾	Ir [A]	630	630	1250	1250	1600	2000	2500 ⁽²⁾	3150 ⁽³⁾		
		16	16	16	16	16	16	16	–		
Rated breaking capacity (rated short-circuit breaking current symmetrical)	Isc [kA]	20	20	20	20	20	20	20	–		
		25	25	25	25	25	25	25	–		
		–	–	31.5	–	31.5	31.5	31.5	31.5		
Rated short-time withstand current (3s)	Ik [kA]	16	16	16	16	16	16	16	–		
		20	20	20	20	20	20	20	–		
		25	25	25	25	25	25	25	–		
Making capacity	Ip [kA]	–	–	31.5	–	31.5	31.5	31.5	31.5		
		40	40	40	40	40	40	40	–		
		50	50	50	50	50	50	50	–		
		63	63	63	63	63	63	63	–		
		–	–	80	–	80	80	80	80		
Operation sequence	[O - 0.3 s - CO - 15 s - CO]	•	•	•	•	•	•	•	•		
Opening time	[ms]	33 ... 60									
Arcing time	[ms]	10 ... 15									
Total breaking time	[ms]	43 ... 75									
Closing time	[ms]	60 ... 80									
Maximum overall dimensions		H [mm]	794	794	794	794	838	838	838	838	
		W [mm]	653	853	653	853	853	853	853	853	853
		D [mm]	802	802	802	802	790	790	790	790	790
		Pole distance P [mm]	210	275	210	275	275	275	275	275	275
Weight	[kg]	140	148	140/146 ⁽⁴⁾	148	228	228	228	277	277	
Standardised table of dimensions	TN	7413	7414	–	7414	7418	7418	7418	–	–	
	1VCD	–	–	000173 ⁽⁴⁾	–	–	–	–	–	000177	
Operating temperature	[°C]	- 5 ... + 40									
Tropicalization	IEC: 60068-2-30, 60721-2-1	•									
Electromagnetic compatibility	IEC: 62271-1	•									

(1) Rated current guaranteed with circuit-breaker installed in UniGear ZS1 switchgear and with 40 °C ambient temperature.

(2) 2300 A rated current guaranteed with natural ventilation; 2500 A rated current guaranteed with forced ventilation.

(3) 2700 A rated current guaranteed with natural ventilation; 3150 A rated current guaranteed with forced ventilation.

(4) 31.5 kA version.

General characteristics of withdrawable circuit-breakers for UniGear ZS2 switchgear and PowerCube modules (36 kV)



Circuit-breaker		VD4/W 36				
Standards	IEC 62271-100 VDE 0671; CEI 17-1 (File 1375)	•	•	•	•	
Rated voltage	Ur [kV]	36				
Rated insulation voltage	Us [kV]	36				
Withstand voltage at 50 Hz	Ud (1 min) [kV]	70				
Impulse withstand voltage	Up [kV]	170				
Rated frequency	fr [Hz]	50-60				
Rated normal current (40 °C) ⁽¹⁾	Ir [A]	1250	1600	2000	2500 ^(*)	
Rated breaking capacity (rated short-circuit breaking current symmetrical)	Isc [kA]	–	–	–	–	
		31.5	31.5	31.5	31.5	
		–	–	–	–	
Rated short-time withstand current (3s)	Ik [kA]	–	–	–	–	
		31.5	31.5	31.5	31.5	
		–	–	–	–	
Making capacity	Ip [kA]	–	–	–	–	
		80	80	80	80	
		–	–	–	–	
Operation sequence	[O - 0.3 s - CO - 15 s - CO]	•	•	•	•	
Opening time	[ms]	33 ... 60				
Arcing time	[ms]	10 ... 15				
Total breaking time	[ms]	45 ... 75				
Closing time	[ms]	60 ... 80				
Maximum overall dimensions		H [mm]	973	973	973	973
		W [mm]	842	842	842	842
		D [mm]	788	788	788	788
		Pole distance P [mm]	275	275	275	275
Weight	[kg]	230	230	230	–	
Standardised table of dimensions	TN	1VYN300901-KG	1VYN300901-KG	1VYN300901-KG	–	
Operating temperature	[°C]	- 5 ... + 40				
Tropicalization	IEC: 60068-2-30, 60721-2-1	•				
Electromagnetic compatibility	IEC: 62271-1	•				

(*) Ask ABB

5.5.2. Types of withdrawable circuit-breakers available for UniGear ZS1 switchgear

VD4 withdrawable circuit-breaker (12 kV)

Ur	Isc	Rated uninterrupted current (40 °C) [A]					Circuit-breaker type
		W=650 P=150 u/l=205 ø=35	W=800 P=210 u/l=310 ø=79	W=1000 P=275 u/l=310 ø=79	W=1000 P=275 u/l=310 ø=109	W=1000 P=275 u/l=310 ø=109	
12	16	630					VD4/P 12.06.16 p150
	20	630					VD4/P 12.06.20 p150
	25	630					VD4/P 12.06.25 p150
	31.5	630					VD4/P 12.06.32 p150
	16	1250					VD4/P 12.12.16 p150
	20	1250					VD4/P 12.12.20 p150
	25	1250					VD4/P 12.12.25 p150
	31.5	1250					VD4/P 12.12.32 p150
	40		1250				VD4/P 12.12.40 p210
	50		1250				VD4/P 12.12.50 p210
	20		1600				VD4/P 12.16.20 p210
	25		1600				VD4/P 12.16.25 p210
	31.5		1600				VD4/P 12.16.32 p210
	40		1600				VD4/P 12.16.40 p210
	50		1600				VD4/P 12.16.50 p210
	20		2000				VD4/P 12.20.20 p210
	25		2000				VD4/P 12.20.25 p210
	31.5		2000				VD4/P 12.20.32 p210
	40		2000				VD4/P 12.20.40 p210
	50		2000				VD4/P 12.20.50 p210
	40			1250			VD4/P 12.12.40 p275
	20			1600			VD4/P 12.16.20 p275
	25			1600			VD4/P 12.16.25 p275
	31.5			1600			VD4/P 12.16.32 p275
	40			1600			VD4/P 12.16.40 p275
	50			1600			VD4/P 12.16.50 p275
	20			2000			VD4/P 12.20.20 p275
	25			2000			VD4/P 12.20.25 p275
	31.5			2000			VD4/P 12.20.32 p275
	40			2000			VD4/P 12.20.40 p275
	50			2000			VD4/P 12.20.50 p275
	20				2500		VD4/P 12.25.20 p275
25				2500		VD4/P 12.25.25 p275	
31.5				2500		VD4/P 12.25.32 p275	
40				2500		VD4/P 12.25.40 p275	
50				2500		VD4/P 12.25.50 p275	
20					3150 ⁽¹⁾	VD4/P 12.32.20 p275	
25					3150 ⁽¹⁾	VD4/P 12.32.25 p275	
31.5					3150 ⁽¹⁾	VD4/P 12.32.32 p275	
40					3150 ⁽¹⁾	VD4/P 12.32.40 p275	
50					3150 ⁽¹⁾	VD4/P 12.32.50 p275	

W = Width of the circuit-breaker.

P = Pole horizontal centre distance.

u/l = Distance between bottom and top terminal.

ø = Diameter of the isolating contact.

(1) Up to 4000 A rated current guaranteed with forced ventilation.

VD4 withdrawable circuit-breaker (17.5 kV)

Ur	Isc	Rated uninterrupted current (40 °C) [A]					Circuit-breaker type
		W=650 P=150 u/l=205 ø=35	W=800 P=210 u/l=310 ø=79	W=1000 P=275 u/l=310 ø=79	W=1000 P=275 u/l=310 ø=109	W=1000 P=275 u/l=310 ø=109	
kV	16	630					VD4/P 17.06.16 p150
	20	630					VD4/P 17.06.20 p150
	25	630					VD4/P 17.06.25 p150
	31.5	630					VD4/P 17.06.32 p150
	16	1250					VD4/P 17.12.16 p150
	20	1250					VD4/P 17.12.20 p150
	25	1250					VD4/P 17.12.25 p150
	31.5	1250					VD4/P 17.12.32 p150
	40		1250				VD4/P 17.12.40 p210
	50		1250				VD4/P 17.12.50 p210
	20		1600				VD4/P 17.16.20 p210
	25		1600				VD4/P 17.16.25 p210
	31.5		1600				VD4/P 17.16.32 p210
	40		1600				VD4/P 17.16.40 p210
	50		1600				VD4/P 17.16.50 p210
	20		2000				VD4/P 17.20.20 p210
	25		2000				VD4/P 17.20.25 p210
	31.5		2000				VD4/P 17.20.32 p210
	40		2000				VD4/P 17.20.40 p210
	50		2000				VD4/P 17.20.50 p210
17.5	40			1250			VD4/P 17.12.40 p275
	20			1600			VD4/P 17.16.20 p275
	25			1600			VD4/P 17.16.25 p275
	31.5			1600			VD4/P 17.16.32 p275
	40			1600			VD4/P 17.16.40 p275
	50			1600			VD4/P 17.16.50 p275
	20			2000			VD4/P 17.20.20 p275
	25			2000			VD4/P 17.20.25 p275
	31.5			2000			VD4/P 17.20.32 p275
	40			2000			VD4/P 17.20.40 p275
	50			2000			VD4/P 17.20.50 p275
	20				2500		VD4/P 17.25.20 p275
	25				2500		VD4/P 17.25.25 p275
	31.5				2500		VD4/P 17.25.32 p275
	40				2500		VD4/P 17.25.40 p275
	50				2500		VD4/P 17.25.50 p275
	20					3150 ⁽¹⁾	VD4/P 17.32.20 p275
	25					3150 ⁽¹⁾	VD4/P 17.32.25 p275
	31.5					3150 ⁽¹⁾	VD4/P 17.32.32 p275
	40					3150 ⁽¹⁾	VD4/P 17.32.40 p275
50					3150 ⁽¹⁾	VD4/P 17.32.50 p275	

W = Width of the circuit-breaker.
P = Pole horizontal centre distance.
u/l = Distance between bottom and top terminal.
ø = Diameter of the isolating contact.
(1) Up to 4000 A rated current guaranteed with forced ventilation.

VD4 withdrawable circuit-breaker (24 kV)

Ur	Isc	Rated uninterrupted current (40 °C) [A]				Circuit-breaker type
		W=800	W=1000	W=1000	W=1000	
kV	kA	P=210	P=275	P=275	P=275	
		u/l=310	u/l=310	u/l=310	u/l=310	
		ø=35	ø=35	ø=79	ø=109	
24	16	630				VD4/P 24.06.16 p210
	20	630				VD4/P 24.06.20 p210
	25	630				VD4/P 24.06.25 p210
	16	1250				VD4/P 24.12.16 p210
	20	1250				VD4/P 24.12.20 p210
	25	1250				VD4/P 24.12.25 p210
	31.5	1250				VD4/P 24.12.32 p210
	16		630			VD4/P 24.06.16 p275
	20		630			VD4/P 24.06.20 p275
	25		630			VD4/P 24.06.25 p275
	16		1250			VD4/P 24.12.16 p275
	20		1250			VD4/P 24.12.20 p275
	25		1250			VD4/P 24.12.25 p275
	16			1600		VD4/P 24.16.16 p275
	20			1600		VD4/P 24.16.20 p275
	25			1600		VD4/P 24.16.25 p275
	31.5			1600		VD4/P 24.16.32 p275
	16			2000		VD4/P 24.20.16 p275
	20			2000		VD4/P 24.20.20 p275
	25			2000		VD4/P 24.20.25 p275
	31.5			2000		VD4/P 24.20.32 p275
	16			2300 ⁽¹⁾		VD4/P 24.25.16 p275
	20			2300		VD4/P 24.25.20 p275
	25			2300		VD4/P 24.25.25 p275
	31.5			2300		VD4/P 24.25.32 p275
	31.5				2700 ⁽²⁾	VD4/P 24.32.32 p275

W = Width of the switchgear.

P = Pole horizontal centre distance.

u/l = Distance between bottom and top terminal.

ø = Diameter of the isolating contact.

(1) 2500 A rated current guaranteed with forced ventilation.

(2) 3150 A rated current guaranteed with forced ventilation.

VD4 withdrawable circuit-breaker (36 kV)

Ur	Isc	Rated uninterrupted current (40 °C) [A]				Circuit-breaker type
		Pole type				
kV	kA	H=951				
		D=788				
		u/l=380				
		ø=399	ø=399	ø=399	ø=399	
		P=275	P=275	P=275	P=275	
		W=778	W=778	W=778	W=778	
36	31.5	1250 A				VD4/W 36.12.32 p275
			1600 A			VD4/W 36.16.32 p275
				2000 A		VD4/W 36.20.32 p275
					2500 A (*)	VD4/W 36.25.32 p275

H = Height of the circuit-breaker.

D = Depth of the circuit-breaker.

u/l = Distance between bottom and top terminal.

ø = Diameter of the isolating contact.

P = Pole horizontal centre distance.

W = Width of the circuit-breaker.

(*) = To be released. Contact ABB



VD4 – up to 24 kV

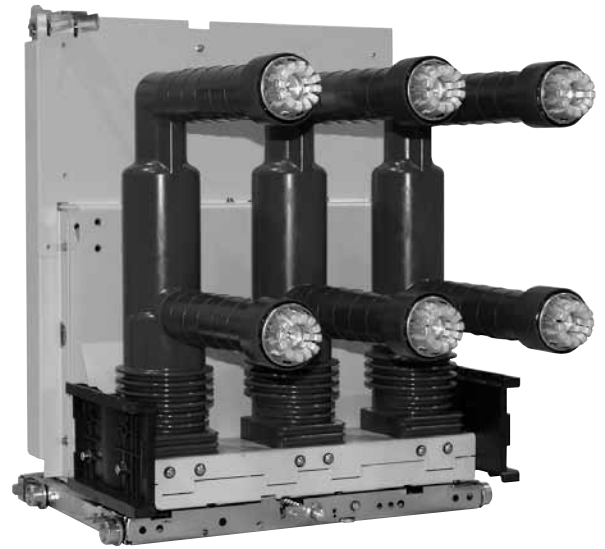

VD4 – up to 24 kV



VD4 - 36 kV

5.5.3. Standard fittings of withdrawable circuit-breakers for UniGear ZS1 switchgear (up to 24 kV) - UniGear ZS2 and PowerCube modules (VD4 36 kV)

The basic versions of the withdrawable circuit-breakers are three-pole and fitted with:

- EL type manual operating mechanism
- mechanical signalling device for closing spring charged/discharged
- mechanical signalling device for circuit-breaker open/closed
- closing pushbutton
- opening pushbutton
- operation counter
- set of ten auxiliary circuit-breaker open/closed contacts

Note: with the set of ten auxiliary contacts supplied as standard and the maximum number of electrical applications possible, three make contacts (signalling circuit-breaker open) and four break contacts (signalling circuit-breaker closed) are available.

- lever for manually charging the closing spring
- isolating contacts
- cord with connector (plug only) for auxiliary circuits, with striker pin which does not allow connection of the plug in the socket if the rated current of the circuit-breaker is different from the rated current of the panel
- racking-in/out lever (the quantity must be defined according to the number of pieces of apparatus ordered)
- locking electromagnet in the truck. This prevents the circuit-breaker from being racked into the panel with auxiliary circuits not connected (plug not inserted in the socket).

5.5.4. General characteristics of withdrawable circuit-breakers for PowerCube modules

General characteristics of withdrawable circuit-breakers for PowerCube modules (12 kV)

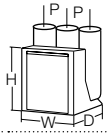

Circuit-breaker	VD4/P 12		VD4/W 12			
	PowerCube module	PB1	PB2			
Standards	IEC 62271-100 VDE 0671; CEI 17-1 (File 1375)	•	•			
Rated voltage	Ur [kV]	12	12			
Rated insulation voltage	Us [kV]	12	12			
Withstand voltage at 50 Hz	Ud (1 min) [kV]	28	28			
Impulse withstand voltage	Up [kV]	75	75			
Rated frequency	fr [Hz]	50-60	50-60			
Rated normal current (40 °C) ⁽¹⁾	Ir [A]	630	1250	630	1250	
		16	16	16	16	
Rated breaking capacity (rated short-circuit breaking current symmetrical)	Isc [kA]	20	20	20	20	
		25	25	25	25	
		31.5	31.5	31.5	31.5	
		-	-	-	-	
		-	-	-	-	
Rated short-time withstand current (3s)	Ik [kA]	16	16	16	16	
		20	20	20	20	
		25	25	25	25	
		31.5	31.5	31.5	31.5	
		-	-	-	-	
Making capacity	Ip [kA]	40	40	40	40	
		50	50	50	50	
		63	63	63	63	
		80	80	80	80	
		-	-	-	-	
Operation sequence	[O - 0.3 s - CO - 15 s - CO]	•	•			
Opening time	[ms]	33 ... 60	33 ... 60			
Arcing time	[ms]	10 ... 15	10 ... 15			
Total breaking time	[ms]	43 ... 75	43 ... 75			
Closing time	[ms]	60 ... 80	60 ... 80			
Maximum overall dimensions		H [mm]	628	628	691	691
		W [mm]	503	503	653	853
		D [mm]	662	662	642	642
		Pole distance P [mm]	150	150	210	210
Weight	[kg]	116	116	135	135	
Standardised table of dimensions	TN	7412	7412	7420	7420	
	1VCD	-	-	-	-	
Operating temperature	[°C]	- 5 ... + 40	- 5 ... + 40			
Tropicalization	IEC: 60068-2-30, 60721-2-1	•	•			
Electromagnetic compatibility	IEC: 62271-1	•	•			

(1) Rated current guaranteed with circuit-breaker installed in PowerCube enclosure and with 40 °C ambient temperature
(2) Up to 4000 A rated current guaranteed with forced ventilation. Available on request.

VD4/P 12								VD4/W 12			
PB2								PB3		PB3	
•								•		•	
•								•		•	
12								12		12	
12								12		12	
28								28		28	
75								75		75	
50-60								50-60		50-60	
1250	1250	1600	1600	1600	2000	2000	2500	2500	3150 ⁽²⁾	3150 ⁽²⁾	
-	-	-	-	-	-	-	-	-	-	-	-
-	-	20	-	-	20	-	20	-	20	-	-
-	-	25	-	-	25	-	25	-	25	-	-
-	-	31.5	-	-	31.5	-	31.5	-	31.5	-	-
40	-	-	40	-	40	-	40	-	40	-	-
-	50	-	-	50	-	50	-	50	-	50	-
-	-	-	-	-	-	-	-	-	-	-	-
-	-	20	-	-	20	-	20	-	20	-	-
-	-	25	-	-	25	-	25	-	25	-	-
-	-	31.5	-	-	31.5	-	31.5	-	31.5	-	-
40	-	-	40	-	40	-	40	-	40	-	-
-	50	-	-	50	-	50	-	50	-	50	-
-	-	-	-	-	-	-	-	-	-	-	-
-	-	50	-	-	50	-	50	-	50	-	-
-	-	63	-	-	63	-	63	-	63	-	-
-	-	80	-	-	80	-	80	-	80	-	-
100	-	-	100	-	100	-	100	-	100	-	-
-	125	-	-	125	-	125	-	125	-	125	-
•								•		•	
33 ... 60								33 ... 60		33 ... 60	
10 ... 15								10 ... 15		10 ... 15	
43 ... 75								43 ... 75		43 ... 75	
60 ... 80								60 ... 80		60 ... 80	
691	691	691	691	691	690	691	691	691	730	691	
653	681	653	653	681	653	681	853	853	853	853	
641	643	642	641	643	642	643	640	643	640	643	
210	210	210	210	210	210	210	275	275	275	275	
174	180	160	174	180	160	190	186	225	221	240	
-	-	7415	-	-	7415	-	7417	-	-	-	
003284	003444	-	003284	003444	-	003444	-	003445	000152	003596	
- 5 ... + 40								- 5 ... + 40		- 5 ... + 40	
•								•		•	
•								•		•	

General characteristics of withdrawable circuit-breakers for PowerCube modules (17.5 kV)

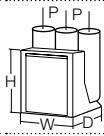

Circuit-breaker	VD4/P 17		VD4/W 17			
	PowerCube module	PB1	PB2			
Standards	IEC 62271-100 VDE 0671; CEI 17-1 (File 1375)	•	•			
Rated voltage	Ur [kV]	17.5	17.5			
Rated insulation voltage	Us [kV]	17.5	17.5			
Withstand voltage at 50 Hz	Ud (1 min) [kV]	38	38			
Impulse withstand voltage	Up [kV]	95	95			
Rated frequency	fr [Hz]	50-60	50-60			
Rated normal current (40 °C) ⁽¹⁾	Ir [A]	630	1250	630	1250	
		16	16	16	16	
Rated breaking capacity (rated short-circuit breaking current symmetrical)	Isc [kA]	20	20	20	20	
		25	25	25	25	
		31.5	31.5	31.5	31.5	
		–	–	–	–	
		–	–	–	–	
Rated short-time withstand current (3s)	Ik [kA]	16	16	16	16	
		20	20	20	20	
		25	25	25	25	
		31.5	31.5	31.5	31.5	
		–	–	–	–	
Making capacity	Ip [kA]	40	40	40	40	
		50	50	50	50	
		63	63	63	63	
		80	80	80	80	
		–	–	–	–	
Operation sequence	[O - 0.3 s - CO - 15 s - CO]	•	•			
Opening time	[ms]	33 ... 60	33 ... 60			
Arcing time	[ms]	10 ... 15	10 ... 15			
Total breaking time	[ms]	43 ... 75	43 ... 75			
Closing time	[ms]	60 ... 80	60 ... 80			
Maximum overall dimensions		H [mm]	628	628	691	691
		W [mm]	503	503	653	853
		D [mm]	662	662	642	642
		Pole distance P [mm]	150	150	210	210
Weight	[kg]	116	116	135	135	
Standardised table of dimensions	TN	7412	7412	7420	7420	
	1VCD	–	–	–	–	
Operating temperature	[°C]	- 5 ... + 40	- 5 ... + 40			
Tropicalization	IEC: 60068-2-30, 60721-2-1	•	•			
Electromagnetic compatibility	IEC: 62271-1	•	•			

(1) Rated current guaranteed with circuit-breaker installed in PowerCube enclosure and with 40 °C ambient temperature.

(2) Up to 4000 A rated current guaranteed with forced ventilation. Available on request.

VD4/P 17								VD4/W 17			
PB2								PB3		PB3	
•								•		•	
•								•		•	
17.5								17.5		17.5	
17.5								17.5		17.5	
38								38		38	
95								95		95	
50-60								50-60		50-60	
1250	1250	1600	1600	1600	2000	2000	2500	2500	3150 ⁽²⁾	3150 ⁽²⁾	
-	-	-	-	-	-	-	-	-	-	-	-
-	-	20	-	-	20	-	20	-	-	-	20
-	-	25	-	-	25	-	25	-	-	-	25
-	-	31.5	-	-	31.5	-	31.5	-	-	-	31.5
40	-	-	40	-	40	-	40	-	-	-	40
-	50	-	-	50	-	50	-	50	50	50	-
-	-	-	-	-	-	-	-	-	-	-	-
-	-	20	-	-	20	-	20	-	-	-	20
-	-	25	-	-	25	-	25	-	-	-	25
-	-	31.5	-	-	31.5	-	31.5	-	-	-	31.5
40	-	-	40	-	40	-	40	-	-	-	40
-	50	-	-	50	-	50	-	50	50	50	-
-	-	-	-	-	-	-	-	-	-	-	-
-	-	50	-	-	50	-	50	-	-	-	50
-	-	63	-	-	63	-	63	-	-	-	63
-	-	80	-	-	80	-	80	-	-	-	80
100	-	-	100	-	100	-	100	-	-	-	100
-	125	-	-	125	-	125	-	125	125	125	-
•								•		•	
33 ... 60								33 ... 60		33 ... 60	
10 ... 15								10 ... 15		10 ... 15	
43 ... 75								43 ... 75		43 ... 75	
60 ... 80								60 ... 80		60 ... 80	
691	691	691	691	691	690	691	691	691	691	691	730
653	681	653	653	681	653	681	853	853	853	853	853
641	643	642	641	643	642	643	640	643	643	643	640
210	210	210	210	210	210	210	275	275	275	275	275
174	180	160	174	180	160	190	186	225	240	240	221
-	-	7415	-	-	7415	-	7417	-	-	-	-
003284	003444	-	003284	003444	-	003444	-	003445	003596	003596	000152
- 5 ... + 40							- 5 ... + 40		- 5 ... + 40		
•								•		•	
•								•		•	

General characteristics of withdrawable circuit-breakers for PowerCube modules (24 kV)

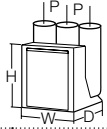

Circuit-breaker	VD4/P 24						
	PowerCube module	PB4		PB5			
Standards	IEC 62271-100	•		•			
	VDE 0671; CEI 17-1 (File 1375)	•		•			
Rated voltage	Ur [kV]	24		24			
Rated insulation voltage	Us [kV]	24		24			
Withstand voltage at 50 Hz	Ud (1 min) [kV]	50		50			
Impulse withstand voltage	Up [kV]	125		125			
Rated frequency	fr [Hz]	50-60		50-60			
Rated normal current (40 °C) ⁽¹⁾	Ir [A]	630	1250	1600	2000	2500 ⁽²⁾	
		16	16	16	16	16	
Rated breaking capacity (rated short-circuit breaking current symmetrical)	Isc [kA]	20	20	20	20	20	
		25	25	25	25	25	
		–	31.5	31.5	31.5	31.5	
		16	16	16	16	16	
Rated short-time withstand current (3s)	Ik [kA]	20	20	20	20	20	
		25	25	25	25	25	
		–	31.5	31.5	31.5	31.5	
		40	40	40	40	40	
Making capacity	Ip [kA]	50	50	50	50	50	
		63	63	63	63	63	
		–	80	80	80	80	
		40	40	40	40	40	
Operation sequence	[O - 0.3 s - CO - 15 s - CO]	•	•	•	•	•	
Opening time	[ms]	33 ... 60		33 ... 60			
Arcing time	[ms]	10 ... 15		10 ... 15			
Total breaking time	[ms]	43 ... 75		43 ... 75			
Closing time	[ms]	60 ... 80		60 ... 80			
Maximum overall dimensions		H [mm]	794	794	838	838	838
		W [mm]	653	653	853	853	853
		D [mm]	802	802	790	790	790
		Pole distance P [mm]	210	210	275	275	275
Weight	[kg]	140	140/146 ⁽³⁾	228	228	228	
Standardised table of dimensions	TN	7413	7413	7418	7418	7418	
	1VCD	–	000173 ⁽³⁾	–	–	–	
Operating temperature	[°C]	- 5 ... + 40					
Tropicalization	IEC: 60068-2-30, 60721-2-1	•					
Electromagnetic compatibility	IEC: 62271-1	•					

(1) Rated current guaranteed with circuit-breaker installed in PowerCube enclosure and with 40 °C ambient temperature.

(2) 2300 A rated uninterrupted current guaranteed with natural ventilation; 2500 A rated current guaranteed with forced ventilation.

(3) 31.5 kA version.

5.5.5. Types of withdrawable circuit-breakers available for PowerCube modules

VD4 withdrawable circuit-breaker (12 kV)

Ur	Isc	Rated uninterrupted current (40 °C) [A]					Circuit-breaker type
		W=650 P=150 u/l=205 ø=35	W=800 P=210 u/l=310 ø=79	W=1000 P=275 u/l=310 ø=79	W=1000 P=275 u/l=310 ø=109	W=1000 P=275 u/l=310 ø=109	
12	16	630					VD4/P 12.06.16 p150
	20	630					VD4/P 12.06.20 p150
	25	630					VD4/P 12.06.25 p150
	31.5	630					VD4/P 12.06.32 p150
	16	1250					VD4/P 12.12.16 p150
	20	1250					VD4/P 12.12.20 p150
	25	1250					VD4/P 12.12.25 p150
	31.5	1250					VD4/P 12.12.32 p150
	16		630				VD4/W 12.06.16 p210
	20		630				VD4/W 12.06.20 p210
	25		630				VD4/W 12.06.25 p210
	31.5		630				VD4/W 12.06.32 p210
	16		1250				VD4/W 12.12.16 p210
	20		1250				VD4/W 12.12.20 p210
	25		1250				VD4/W 12.12.25 p210
	31.5		1250				VD4/W 12.12.32 p210
	40		1250				VD4/P 12.12.40 p210
	50		1250				VD4/P 12.12.50 p210
	20			1600			VD4/P 12.16.20 p210
	25			1600			VD4/P 12.16.25 p210
	31.5			1600			VD4/P 12.16.32 p210
	40			1600			VD4/P 12.16.40 p210
	50			1600			VD4/P 12.16.50 p210
	20			2000			VD4/P 12.20.20 p210
	25			2000			VD4/P 12.20.25 p210
	31.5			2000			VD4/P 12.20.32 p210
	40			2000			VD4/P 12.20.40 p210
	50			2000			VD4/P 12.20.50 p210
	20				2500		VD4/P 12.25.20 p275
	25				2500		VD4/P 12.25.25 p275
	31.5				2500		VD4/P 12.25.32 p275
40				2500		VD4/P 12.25.40 p275	
50				2500		VD4/P 12.25.50 p275	
20					3150 ⁽¹⁾	VD4/W 12.32.20 p275	
25					3150 ⁽¹⁾	VD4/W 12.32.25 p275	
31.5					3150 ⁽¹⁾	VD4/W 12.32.32 p275	
40					3150 ⁽¹⁾	VD4/W 12.32.40 p275	
50					3150 ⁽¹⁾	VD4/W 12.32.50 p275	

W = Width of the switchgear.

P = Pole horizontal centre distance.

u/l = Distance between bottom and top terminal.

ø = Diameter of the isolating contact.

(1) Up to 4000 A rated current guaranteed with forced ventilation. Available on request.

VD4 withdrawable circuit-breaker (17.5 kV)

Ur	Isc	Rated uninterrupted current (40 °C) [A]					Circuit-breaker type
		W=650 P=150 u/l=205 ø=35	W=800 P=210 u/l=310 ø=79	W=1000 P=275 u/l=310 ø=79	W=1000 P=275 u/l=310 ø=109	W=1000 P=275 u/l=310 ø=109	
17.5	16	630					VD4/P 17.06.16 p150
		20	630				VD4/P 17.06.20 p150
		25	630				VD4/P 17.06.25 p150
		31.5	630				VD4/P 17.06.32 p150
	20	1250					VD4/P 17.12.16 p150
		20	1250				VD4/P 17.12.20 p150
		25	1250				VD4/P 17.12.25 p150
		31.5	1250				VD4/P 17.12.32 p150
	25		630				VD4/W 17.06.16 p210
			630				VD4/W 17.06.20 p210
			630				VD4/W 17.06.25 p210
			630				VD4/W 17.06.32 p210
	31.5		1250				VD4/W 17.12.16 p210
			1250				VD4/W 17.12.20 p210
			1250				VD4/W 17.12.25 p210
			1250				VD4/W 17.12.32 p210
40		1250				VD4/P 17.12.40 p210	
		1250				VD4/P 17.12.50 p210	
			1600			VD4/P 17.16.20 p210	
			1600			VD4/P 17.16.25 p210	
50			1600			VD4/P 17.16.32 p210	
			1600			VD4/P 17.16.40 p210	
			1600			VD4/P 17.16.50 p210	
			2000			VD4/P 17.20.20 p210	
2500			2000			VD4/P 17.20.25 p210	
			2000			VD4/P 17.20.32 p210	
			2000			VD4/P 17.20.40 p210	
			2000			VD4/P 17.20.50 p210	
3150 ⁽¹⁾				2500		VD4/P 17.25.20 p275	
				2500		VD4/P 17.25.25 p275	
				2500		VD4/P 17.25.32 p275	
				2500		VD4/P 17.25.40 p275	
3150 ⁽¹⁾				2500		VD4/P 17.25.50 p275	
					3150 ⁽¹⁾	VD4/W 17.32.20 p275	
					3150 ⁽¹⁾	VD4/W 17.32.25 p275	
					3150 ⁽¹⁾	VD4/W 17.32.32 p275	
3150 ⁽¹⁾					3150 ⁽¹⁾	VD4/W 17.32.40 p275	
					3150 ⁽¹⁾	VD4/W 17.32.50 p275	

W = Width of the switchgear.

P = Pole horizontal centre distance.

u/l = Distance between bottom and top terminal.

ø = Diameter of the isolating contact.

(1) Up to 4000 A rated current guaranteed with forced ventilation. Available on request.

VD4 withdrawable circuit-breaker (24 kV)

Ur	Isc	Rated uninterrupted current (40 °C) [A]		Circuit-breaker type
		W=800	W=1000	
kV	kA	P=210	P=275	
		u/l=310	u/l=310	
		ø=35	ø=79	
24	16	630		VD4/P 24.06.16 p210
	20	630		VD4/P 24.06.20 p210
	25	630		VD4/P 24.06.25 p210
	16	1250		VD4/P 24.12.16 p210
	20	1250		VD4/P 24.12.20 p210
	25	1250		VD4/P 24.12.25 p210
	31.5	1250		VD4/P 24.12.32 p210
	16		1600	VD4/P 24.16.16 p275
	20		1600	VD4/P 24.16.20 p275
	25		1600	VD4/P 24.16.25 p275
	31.5		1600	VD4/P 24.16.32 p275
	16		2000	VD4/P 24.20.16 p275
	20		2000	VD4/P 24.20.20 p275
	25		2000	VD4/P 24.20.25 p275
	31.5		2000	VD4/P 24.20.32 p275
	16		2300 ⁽¹⁾	VD4/P 24.25.16 p275
	20		2300 ⁽¹⁾	VD4/P 24.25.20 p275
	25		2300 ⁽¹⁾	VD4/P 24.25.25 p275
	31.5		2300 ⁽¹⁾	VD4/P 24.25.32 p275

W = Width of the switchgear.

P = Pole horizontal centre distance.

u/l = Distance between bottom and top terminal.

Ø = Diameter of the isolating contact.

(1) Up to 2500 A rated current guaranteed with forced ventilation. Available on request.

5.5.6. Standard fittings for withdrawable circuit-breakers for PowerCube modules

The basic versions of the withdrawable circuit-breakers are always three-pole and fitted with:

- EL type manual operating mechanism
- mechanical signalling device for closing spring charged/discharged
- mechanical signalling device for circuit-breaker open/closed
- closing pushbutton
- opening pushbutton
- operation counter
- set of ten auxiliary circuit-breaker open/closed contacts
Note: with the group of ten auxiliary contacts supplied as standard and the maximum number of electrical applications, three make contacts (signalling circuit-breaker open) and four break contacts (signalling circuit-breaker closed) are available.
- lever for manually charging the closing spring
- isolating contacts
- cord with connector (only plug) for auxiliary circuits, with striker pin which does not allow connection of the plug in the socket if the rated current of the circuit-breaker is different from the rated current of the panel
- racking-in/out lever (the quantity must be defined according to the number of pieces of apparatus ordered)
- locking electromagnet in the truck. This prevents racking-in of the circuit-breaker in the panel with auxiliary circuits not connected (plug not inserted in the socket).



5.5.7. General characteristics of withdrawable circuit-breakers for ZS8.4 switchgear



Circuit-breaker		VD4/Z8					
	Panel without partitions	•					
	Panel with partitions	–					
	Preussen Elektra - EON ⁽²⁾	–					
	Width [kV]	650	650	650	650	800	800
	Depth [kV]	1000	1000	1000	1000	1200	1200
	IEC 62271-100	•					
	VDE 0671	•					
Rated voltage	Ur [kV]	12	12	17.5	17.5	24	24
Rated insulation voltage	Us [kV]	12	12	17.5	17.5	24	24
Withstand voltage at 50 Hz	Ud (1 min) [kV]	28	28	38	38	50	50
Impulse withstand voltage	Up [kV]	75	75	95	95	125	125
Rated frequency	fr [Hz]	50-60					
Rated normal current (40 °C) ⁽¹⁾	Ir [A]	630	1250	630	1250	630	1250
Rated breaking capacity (rated symmetrical short-circuit current)	Isc [kA]	–	–	–	–	16	16
		20	20	20	20	20	20
Rated short-time withstand current (3 s)	Ik [kA]	–	–	–	–	16	16
		20	20	20	20	20	20
Making capacity	Ip [kA]	–	–	–	–	40	40
		18,5 mm	50	50	50	50	50
		63	63	63	63	63	63
Operation sequence	[O-0.3s-CO-15s-CO]	•					
Opening time	[ms]	33...60					
Arcing time	[ms]	10...15					
Total breaking time	[ms]	43...75					
Closing time	[ms]	60...80					
Maximum overall dimensions	H [mm]	579	579	579	579	680	680
	W [mm]	503	503	503	503	653	653
	D [mm]	548	548	548	548	646	646
	Pole distance P [mm]	150	150	150	150	210	210
Weight	[kg]	116	116	116	116	140	140
Standardised table of dimensions	1VCD	000092	000137	000137	000137	000089	000138
Operating temperature	[°C]	– 5 ... + 40					
Tropicalisation	IEC 60068-2-30	•					
	IEC 60721-2-1	•					
Electromagnetic compatibility	IEC 62271-1	•					

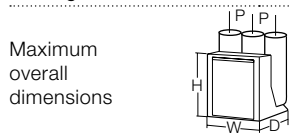

(1) Rated current guaranteed with circuit-breaker installed in switchgear with 40 °C ambient temperature.

(2) Special type with device for charging the closing spring by means of a rotary handle outside the operating mechanism.

VD4/ZT8						VD4/ZS8				
-						-				
•						•				
-						-				
650	650	650	650	800	800	650	650	800	800	
1200	1200	1200	1200	1200	1200	1200	1200	1200	1200	
•						•				
•						•				
12	12	17.5	17.5	24	24	12	12	24	24	
12	12	17.5	17.5	24	24	12	12	24	24	
28	28	38	38	50	50	28	28	50	50	
75	75	95	95	125	125	75	75	125	125	
50-60						50-60				
630	1250	630	1250	630	1250	630	1250	630	1250	
-	-	-	-	16	16	-	-	16	16	
20	20	20	20	20	20	20	20	20	20	
25	25	25	25	25	25	25	25	25	25	
-	-	-	-	16	16	-	-	16	16	
20	20	20	20	20	20	20	20	20	20	
25	25	25	25	25	25	25	25	25	25	
-	-	-	-	40	40	-	-	40	40	
50	50	50	50	50	50	50	50	50	50	
63	63	63	63	63	63	63	63	63	63	
•						•				
33...60						40...60				
10...15						10...15				
43...75						50...75				
60...80						60...80				
579	579	579	579	680	680	579	579	680	680	
503	503	503	503	653	653	503	503	653	653	
638	638	638	638	646	646	638	638	646	646	
150	150	150	150	210	210	150	150	210	210	
116	116	116	116	140	140	116	116	140	140	
000093	000134	000134	000134	000090	000136	000091	000133	000088	000135	
- 5 ... + 40						- 5 ... + 40				
•						•				
•						•				
•						•				

5.5.8. General characteristics of withdrawable circuit-breakers for ZS8.4 switchgear

VD4/ZS8 - VD4/ZT8 - VD4/Z8 withdrawable circuit-breaker for ZS8.4 switchgear

Ur	Isc	Rated uninterrupted current (40 °C) [A]						Circuit-breaker type
		Panel with partition		Panel without partition		Special panel EON		
kV	kA	W = 650	W = 800	W = 650	W = 800	W = 650	W = 800	
		P = 150	P = 210	P = 150	P = 210	P = 150	P = 210	
		u/l = 205	u/l = 310	u/l = 205	u/l = 310	u/l = 205	u/l = 310	
		ø = 35	ø = 35	ø = 35	ø = 35	ø = 35	ø = 35	
12	20	630						VD4/ZS8 12.06.20 p150
	25	630						VD4/ZS8 12.06.25 p150
	20	1250						VD4/ZS8 12.12.20 p150
	25	1250						VD4/ZS8 12.12.25 p150
	20			630				VD4/ZT8 12.06.20 p150
	25			630				VD4/ZT8 12.06.25 p150
	20			1250				VD4/ZT8 12.12.20 p150
	25			1250				VD4/ZT8 12.12.25 p150
	20					630		VD4/ZS8 12.06.20 p150
	25					630		VD4/ZS8 12.06.25 p150
	20					1250		VD4/ZS8 12.12.20 p150
	25					1250		VD4/ZS8 12.12.25 p150
17.5	20	630						VD4/Z8 17.06.20 p150
	25	630						VD4/Z8 17.06.25 p150
	20	1250						VD4/Z8 17.12.20 p150
	25	1250						VD4/Z8 17.12.25 p150
	20			630				VD4/ZT8 17.06.20 p150
	25			630				VD4/ZT8 17.06.25 p150
	20			1250				VD4/ZT8 17.12.20 p150
	25			1250				VD4/ZT8 17.12.25 p150
24	16		630					VD4/ZS8 24.06.16 p210
	20		630					VD4/ZS8 24.06.20 p210
	25		630					VD4/ZS8 24.06.25 p210
	16		1250					VD4/ZS8 24.12.16 p210
	20		1250					VD4/ZS8 24.12.20 p210
	25		1250					VD4/ZS8 24.12.25 p210
	16			630				VD4/ZT8 24.06.16 p210
	20			630				VD4/ZT8 24.06.20 p210
	25			630				VD4/ZT8 24.06.25 p210
	16			1250				VD4/ZT8 24.12.16 p210
	20			1250				VD4/ZT8 24.12.20 p210
	25			1250				VD4/ZT8 24.12.25 p210
	16					630		VD4/ZS8 24.06.16 p210
	20					630		VD4/ZS8 24.06.20 p210
	25					630		VD4/ZS8 24.06.25 p210
	16					1250		VD4/ZS8 24.12.16 p210
	20					1250		VD4/ZS8 24.12.20 p210
	25					1250		VD4/ZS8 24.12.25 p210

W = Width of the switchgear.
P = Pole horizontal centre distance.
u/l = Distance between bottom and top terminal.
Ø = Diameter of the isolating contact.

5.5.9. Standard fittings for withdrawable circuit-breakers for ZS8.4 switchgear

The basic versions of the withdrawable circuit-breakers are always three-pole and fitted with:

- EL type manual operating mechanism
- mechanical signalling device for closing spring charged/discharged
- mechanical signalling device for circuit-breaker open/closed
- closing pushbutton
- opening pushbutton
- operation counter
- set of ten auxiliary circuit-breaker open/closed contacts
Note: with the set of ten auxiliary contacts supplied as standard and the maximum number of electrical applications possible, three make contacts (signalling circuit-breaker open) and four break contacts (signalling circuit-breaker closed) are available.
- lever for manually charging the closing springs incorporated in the operating mechanism for VD4/Z8 and VD4/ZT8, external with rotary movement for VD4/ZS8
- isolating contacts
- cord with connector (only plug) for auxiliary circuits, with striker pin which does not allow connection of the plug in the socket if the rated current of the circuit-breaker is different from the rated current of the panel
- racking-in/out lever (the quantity must be defined according to the number of pieces of apparatus ordered)

5.5.10. VD4/ZS8 (Preussen Elektra-EON version)

- Device for recharging the closing spring, with door closed, by means of removable rotary handle and outside the operating mechanism and the switchgear
- 64-pin Harting socket with mechanical interlock which prevents traverse of the circuit-breaker when the plug is not inserted in the socket
- Interlock with the door which prevents insertion of the spring charging lever when the circuit-breaker is closed
- Interlock with the door and the 64-pin Harting socket which prevents door closure when the plug is not inserted in the socket.

5.5.11. VD4/Z8 - VD4/ZT8

- Harting 64-pin socket with mechanical interlock which prevents traverse of the circuit-breaker when the plug is not inserted in the socket.



Caption

- 1) Device for spring charging with rotary handle
- 2) Harting 64-pin socket with mechanical interlock which prevents traverse when the socket is not inserted
- 3) Door-socket-spring charging device interlock (only VD4/ZS8 version)

5.5.12. General characteristics of withdrawable circuit-breakers for UniSwitch switchgear and UniMix (24 kV) switchgear



Circuit-breaker		VD4/US 24 ⁽³⁾	VD4/US 24 ⁽⁴⁾
	UniSwitch (unit CBW type)	•	–
	UniMix (unit P1/E type)	–	•
Standards	IEC 62271-100	•	•
	VDE 0671; CEI 17-1 (File 1375)	•	•
Rated voltage	Ur [kV]	24	24
Rated insulation voltage	Us [kV]	24	24
Withstand voltage at 50 Hz	Ud (1 min) [kV]	50	50
Impulse withstand voltage	Up [kV]	125	125
Rated frequency	fr [Hz]	50-60	50-60
Rated normal current (40 °C) ⁽¹⁾	Ir [A]	630	1250
		16 (20) ⁽⁵⁾	16 (25) ⁽⁵⁾
Rated breaking capacity (rated symmetrical short-circuit current)	Isc [kA]	20 (25) ⁽⁵⁾	20 (25) ⁽⁵⁾
		–	25
Rated short-time withstand current (3 s) ⁽²⁾	I _k [kA]	16 (20) ⁽⁵⁾	16 (25) ⁽⁵⁾
		20 (25) ⁽⁵⁾	20 (25) ⁽⁵⁾
Making capacity	I _p [kA]	–	25
		40 (50) ⁽⁵⁾	40 (50) ⁽⁵⁾
		50 (63) ⁽⁵⁾	50 (63) ⁽⁵⁾
Operation sequence	[O - 0.3 s - CO - 15 s - CO]	•	•
Opening time	[ms]	33 ... 60	33 ... 60
Arcing time	[ms]	10 ... 15	10 ... 15
Total breaking time	[ms]	43 ... 75	43 ... 75
Closing time	[ms]	60 ... 80	60 ... 80
Maximum overall dimensions	H [mm]	680	680
	W [mm]	653	653
	D [mm]	742	742
	Pole distance P [mm]	210	210
Weight	[kg]	125	125
Standardised table of dimensions	1VCD	000047	000047
Operating temperature	[°C]	- 5 ... + 40	- 5 ... + 40
Tropicalization	IEC: 60068-2-30, 60721-2-1	•	•
Electromagnetic compatibility	IEC 62271	•	•

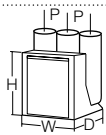

(1) Rated current guaranteed with withdrawable circuit-breaker installed in switchgear with 40 °C ambient temperature

(2) The value and duration of the rated short-time withstand current depends on the switchgear. See the specific catalogues of the UniSwitch and UniMix switchgear

(3) The top shutter activation wheels of the UniSwitch switchgear (CBW unit) are mounted and adjusted by the manufacturer of the UniSwitch switchgear

(4) The top shutter activation wheels of the UniMix switchgear (P1/E unit) are available on request

(5) The values in brackets refer to the 12 kV rated voltage.

5.5.13. General characteristics of withdrawable circuit-breakers for UniSec switchgear



Circuit-breaker	VD4/SEC	
Standards	IEC 62271-100	•
	VDE 0671; CEI 17-1 (File 1375)	•
Rated voltage	Ur [kV]	24
Rated insulation voltage	Us [kV]	24
Withstand voltage at 50 Hz	Ud (1 min) [kV]	50
Impulse withstand voltage	Up [kV]	125
Rated frequency	fr [Hz]	50-60
Rated normal current (40 °C) ⁽¹⁾	Ir [A]	630 - 1250
		16
Rated breaking capacity (rated symmetrical short-circuit current)	Isc [kA]	20
		25
Rated short-time withstand current (3 s) ⁽²⁾		16
	Ik [kA]	20
		25
		40
Making capacity	I _p [kA]	50
		63
Opening time	[O - 0.3 s - CO - 15 s - CO]	•
Opening time	[ms]	33 ... 60
Arcing time	[ms]	10 ... 15
Total breaking time	[ms]	43 ... 75
Closing time	[ms]	60 ... 80
Maximum overall dimensions	H [mm]	743
	W [mm]	653
	D [mm]	742
	Pole distance P [mm]	210
Weight	[kg]	133
Standardised table of dimensions	1VCD	000190
Operating temperature	[°C]	- 5 ... + 40
Tropicalization	IEC: 60068-2-30, 60721-2-1	•
Electromagnetic compatibility	IEC 62271	•

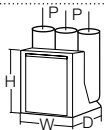

(1) Rated current guaranteed with withdrawable circuit-breaker installed in switchgear with 40 °C ambient temperature.

5.5.14. Standard fittings for withdrawable circuit-breakers for UniSwitch, UniMix and UniSec switchgear

The basic versions of the withdrawable circuit-breakers are three-pole and provided with:

- EL type manual operating mechanism
- Mechanical signalling device for closing spring charged/discharged
- Mechanical signalling device for circuit-breaker open/closed
- Closing pushbutton
- Opening pushbutton
- Operation counter
- Set of ten circuit-breaker open/closed auxiliary contacts
Note: with the set of ten auxiliary contacts supplied as standard and the maximum electrical accessories, three break contacts are available (signalling circuit-breaker open) and four make contacts (signalling circuit-breaker closed).
- Lever for manual charging of the closing spring incorporated in the operating mechanism
- Isolating contacts
- Racking-out/racking-in lever (the quantity must be established according to the number of pieces of apparatus ordered).

VD4 withdrawable circuit-breaker for switchgear UniSwitch (type unit CBW) and UniMix (type unit P1/E)

Ur	Isc	Rated uninterrupted current (40 °C) [A]		
kV	kA	UniSwitch CBW	UniMix P1/E	Circuit-breaker type
		P=210 u/l=310 ø=35	P=210 u/l=310 ø=35	
24	16	630 ⁽¹⁾	630	VD4/US 24.06.16 p210
	20	630 ⁽¹⁾	630	VD4/US 24.06.20 p210
	25	-	630	VD4/US 24.06.25 p210
	16	1250 ⁽¹⁾	1250	VD4/US 24.12.16 p210
	20	1250 ⁽¹⁾	1250	VD4/US 24.12.20 p210
	25	-	1250	VD4/US 24.12.25 p210

(1) 25 kA Isc at the 12 kV rated voltage
P = Pole horizontal centre distance.
u/l = Distance between bottom and top terminal.
ø = Diameter of the isolating contact.

VD4 withdrawable circuit-breaker for switchgear UniSec

Ur	Isc	Rated uninterrupted current (40 °C) [A]		
kV	kA	P=210	Circuit-breaker type	
		u/l=310 ø=35		
24	16	630	VD4/SEC 24.06.16 p210	
	20	630	VD4/SEC 24.06.20 p210	
	25	630	VD4/SEC 24.06.25 p210	
	16	1250	VD4/SEC 24.12.16 p210	
	20	1250	VD4/SEC 24.12.20 p210	
	25	1250	VD4/SEC 24.12.25 p210	

P = Pole horizontal centre distance.
u/l = Distance between bottom and top terminal.
ø = Diameter of the isolating contact.

5.6. Characteristics of the electrical accessories

- Shunt opening release (-MO1)
- Additional shunt opening release (-MO2)
- Shunt closing release (-MC)
- Locking magnet on the actuator (-RL1)

Un	24 - 30 - 48 - 60 - 110 - 125 - 220 - 250 V-
Un	48 - 60 - 110 - 120 - 127 - 220 ... 240 V~ 50 Hz
Un	110 - 120 - 127 - 220 - 240 V~ 60 Hz
Operating limits	70 ... 110% Un
Inrush power (Ps)	DC 200 W; AC = 200 VA
Inrush time	approx. 100 ms
Continuous power (Pc)	DC = 5 W; AC = 5 VA
Opening time	35 ... 60 ms
Closing time	30 ... 80 ms
Insulation voltage	2000 V 50 Hz (for 1 min)

Undervoltage release (-MU)

Un	24 - 30 - 48 - 60 - 110 - 125 - 220 - 250 V-
Un	48 - 60 - 110 - 120 - 127 - 220 ... 240 V~ 50 Hz
Un	110 - 120 ... 127 - 220 ... 240 V~ 60 Hz
Operating limits	
- circuit-breaker opening	35-70% Un
- circuit-breaker closing	85-110% Un
Inrush power (Ps)	DC 200 W; AC = 200 VA
Inrush time	approx. 100 ms
Continuous power	DC = 5 W; AC = 5 VA
Opening time	60 ... 80 ms
Insulation voltage	2000 V 50 Hz (for 1 min)

Electronic time delay device for undervoltage release (mounted outside the circuit-breaker)

Un	24 ... 30 - 48 - 60 - 110 ... 127 - 220 ... 250 V-
Un	48 - 60 - 110 ... 127 - 220 ... 240 V~ 50/60 Hz
Adjustable opening time (release + time delay device)	0.5-1-1.5-2-3 s

Motor for motorised truck (-MT) (only for withdrawable circuit-breakers for UniGear ZS1, UniSec and ZS8.4 switchgear)

Un	24-30-48-60-110-220 V DC
Operating limits	85 ... 110% Un
Rated power (Pn)	40 W

Motor operator (-MS)

Characteristics

Un	24...30 - 48...60 - 110...130 - 220...250 V-	
Un	100...130 - 220...250 V ~ 50/60 Hz	
Operating limits	85 ... 110% Un	
Inrush power (Ps)	≤ 40 kA	50 kA
	DC=600 W; AC=600 VA	DC=900 W; AC=900 VA
Rated power (Pn)	DC=200 W; AC=200 VA	DC=350 W; AC=350 VA
	Inrush time	0.2 s
Charging time	6-7 s	6-7 s
Insulation voltage	2000 V 50 Hz (for 1 min) 2000 V 50 Hz (for 1 min)	

Auxiliary contacts of the circuit-breaker

Rated insulation voltage according to VDE 0110, Group C	660 V AC 800 V DC
Rated voltage	24 V... 660 V
Insulation-test test voltage	2.5 kV
Maximum rated current	10 A
Number of contacts	5
Stroke	6 mm ... 7 mm
Contact force	26 N
On resistance	3 mΩ
Storing temperature range	- 20° C ... + 120 °C
Operating temperature range	- 20° C ... + 70 °C
Contact over temperature	20 K
Operating cycles	30,000
Unlimited short circuit stability by using fuses of max. 10 A time-lag	

Cosφ	Rated current	Breaking capacity	
220 V AC	0.7	2.5 A	25 A
380 V AC	0.7	1.5 A	15 A
500 V AC	0.7	1.5 A	15 A
660 V AC	0.7	1.2 A	12 A
	Time constant		
24 V DC	1 ms	10 A	12 A
	15 ms	10 A	12 A
	50 ms	8 A	10 A
	200 ms	4 A	7.7 A
60 V DC	1 ms	8 A	10 A
	15 ms	6 A	8 A
	50 ms	5 A	6 A
	200 ms	4 A	5.4 A
110 V DC	1 ms	6 A	8 A
	15 ms	4 A	5 A
	50 ms	2 A	4.6 A
	200 ms	1 A	2.2 A
220 V DC	1 ms	1.5 A	2 A
	15 ms	1 A	1.4 A
	50 ms	0.75 A	1.2 A
	200 ms	0.5 A	1 A

Note

With the set of 10 auxiliary contacts supplied as standard, the following are available:

- 3 NO contacts + 5 NC contacts for fixed circuit-breakers
- 3 NO contacts + 4 NC contacts for withdrawable circuit-breakers

With the set of 15 auxiliary contacts (+5 contacts on request compared to the 10 supplied as standard), the following are available:

- for fixed circuit-breaker, as desired, 6 NO contacts + 7 NC contacts or 5 NO contacts + 8 NC contacts or 3 NO contacts + 10 NC contacts
- for withdrawable circuit-breakers, depending on the applications required, a maximum of 6 NO contacts + 6 NC contacts and a minimum of 5 NO contacts + 5 NC contacts are available.

Locking magnet on the truck (-RL2) (*)

Un	24 - 30 - 48 - 60 - 110 - 125 - 127 - 132 - 220 - 240 V-
Un	24 - 30 - 48 - 60 - 110 - 125 - 127 - 220 - 230 ... 240 V~ 50/60 Hz
Operating limits	85 ... 110% Un
Inrush power (Ps)	DC = 250 W; AC = 250 VA
Continuous power (Pc)	DC = 5 W; AC = 5 VA
Inrush time	150 ms

(*) Not available for versions with motorized truck.

6. Instructions for operating the circuit-breaker

6.1. Safety indications



The VD4 circuit-breakers guarantee a minimum IP2X degree of protection when installed in the following conditions:

- fixed circuit-breaker, installed behind a protective metal net
- withdrawable circuit-breaker, installed in switchgear.

Under these conditions the operator is totally guaranteed against accidental contact with moving parts.

Should mechanical operations be carried out on the circuit-breaker outside of the switchgear, take great care of the moving parts.

If the operations are prevented, do not force the mechanical interlocks and check that the operating sequence is correct.

Racking the circuit-breaker in and out of the switchgear must be done gradually to avoid shocks which may deform the mechanical interlocks.

Due to safety reasons, the circuit-breaker has to be treated as "switched on" if the switching position cannot be clearly determined.

In this case all high voltage connections to the circuit-breaker have to be de-energized and zero potential on the primary side of the circuit-breaker has to be confirmed prior to commissioning, operation, maintenance or repair work.

6.2. Switching and signalling parts

VD4 circuit-breakers for UniGear switchgear and PowerCube modules (fig. 6a)

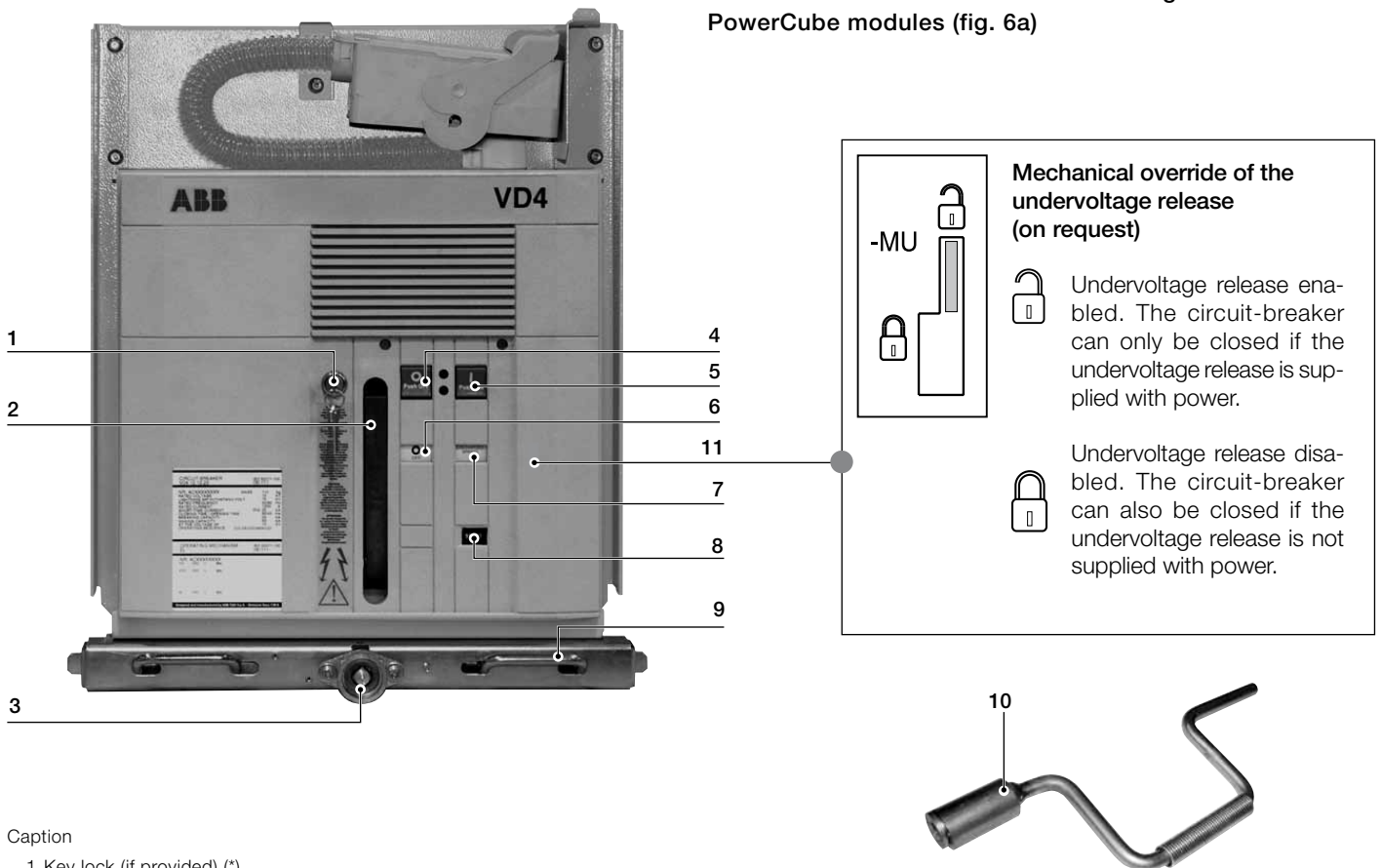

Caption

- 1 Key lock (if provided) (*)
- 2 Lever for manually charging the closing spring (except version VD4/ZS8 - see figure 6b)
- 3 Coupling lever for racking-out operation (withdrawable circuit-breakers only)
- 4 Opening pushbutton
- 5 Closing pushbutton
- 6 Signalling device for circuit-breaker open/closed
- 7 Signalling device for closing springs charged/discharged
- 8 Operation counter.
- 9 Handles for operating the truck locks (only for withdrawable circuit-breakers)
- 10 Operating lever for circuit-breaker racking-in/out (there is a special version for VD4/ZS8)
- 11 Mechanical undervoltage release override (on request).

(*) Warning! To activate the key lock: open the circuit-breaker, keep the opening pushbutton depressed, then turn the key and remove it from the housing.

Fig. 6a

6.3. Circuit-breaker closing and opening operations

Circuit-breaker operation can be either manual or electrical (fig. 6 - fig. 7).

a1) Manual closing spring charging for VD4 circuit-breakers for UniGear switchgear and PowerCube modules (fig. 7a)

Repeatedly activate the charging lever (2) (maximum rotation angle of the lever: about 90°) until the yellow indicator (7) appears.

The maximum forces which can normally be applied to the lever are ≤ 150 N for the EL1 operating mechanism, ≤ 200 N for the EL2 operating mechanism and ≤ 250 N for EL3 operating mechanism.

EL1 Twin and EL2 Twin type operating mechanisms are provided for circuit-breakers with 50 kA breaking capacity. For manual charging, the additional lever (1) should be inserted fully, as indicated in fig. 7c. In this way, the maximum force to be applied is ≤ 200 N. For the type of operating mechanism, please refer to the rating plate in fig. 1.

a2) Closing spring loading in the manual mode for withdrawable VD4 circuit-breakers for UniGear switchgear equipped with a hand-operated rotary loading device for the closing spring (refer to fig. 6b for indicative details)

Rotate the charging lever (2) (rotate about 12 times) until the yellow indicator (7) appears. The maximum force which can normally be applied to the lever is ≤ 150 N for the EL1 operating mechanism and ≤ 230 N for the EL3 operating mechanism.

The operation can be carried out with the door either open or closed and the circuit-breaker either withdrawn or connected.

WARNING (fig. 6b): Fit the hand-operated loading lever of the closing spring (2b) into its housing (2a). Turn the lever clockwise (about 12 times) until the yellow indicator (7) appears to show that loading is complete. Once this happens, the lever will continue for half a turn without loading (without exercising any force), after which it will lock owing to a sudden load increase. Do not exercise force or try to continue loading as this will damage the device.

VD4 circuit-breakers for ZS8.4 switchgear (fig. 6b)

a3) Manual closing spring charging for VD4 circuit-breakers (fig. 7b)

Rotate the charging lever (2) until the yellow indicator (7) appears. The maximum force which can normally be applied to the lever is ≤ 150 N for the EL1 operating mechanism and ≤ 230 N for the EL3 operating mechanism.

The operation can be carried out with the door either open or closed and the circuit-breaker either withdrawn or connected.

WARNING (fig. 6b): Fit the hand-operated loading lever of the closing spring (2b) into its housing (2a). Turn the lever clockwise (about 12 times) until the yellow indicator (7) appears to show that loading is complete. Once this happens, the lever will continue for half a turn without loading (without exercising any force), after which it will lock owing to a sudden load increase. Do not exercise force or try to continue loading as this will damage the device.

b) Electrical spring charging operation

On request, the circuit-breaker can be fitted with the following accessories for electrical operation:

- geared motor for automatic closing spring charging
- shunt closing release
- shunt opening release.

The geared motor automatically recharges the spring after each closing operation until the yellow indicator (7) appears. If the power is cut off during charging, the geared motor stops and automatically starts recharging the springs again when the power returns.

In any case, it is always possible to complete the charging operation manually.

c) Circuit-breaker closing

The operation can only be carried out with the closing spring completely charged.

For manual closing, press the pushbutton (5 - fig. 6b).

When there is a shunt closing release, the operation can also be carried out remotely by means of a special control circuit. Closing having taken place is indicated by the signalling device (6 - fig. 6b).

d) Circuit-breaker opening

For manual opening, press the pushbutton (4 - fig. 6b).

When there is a shunt opening release, the operation can also be carried out remotely by means of a special control circuit. Opening having taken place is indicated by the signalling device (6 - fig. 6b).

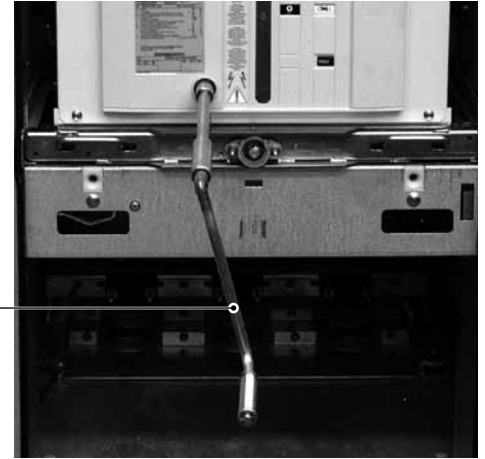
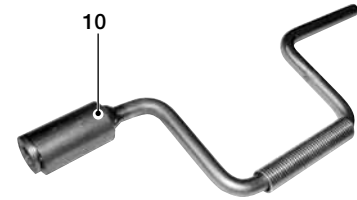
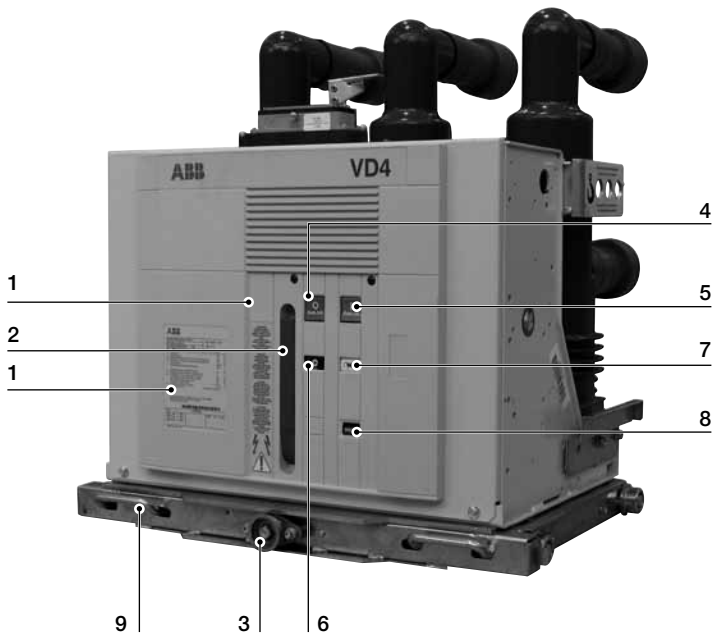

Caption

- 1 Key lock (if provided)
- 2 Lever for manually charging the closing spring
- 2a Coupling for manual closing spring charging (when lever 2 is not provided)
- 2b Lever for manual closing spring charging for rotary charging device
- 3 Coupling for racking-out operation lever (only for withdrawable circuit-breakers)
- 4 Opening pushbutton
- 5 Closing pushbutton
- 6 Signalling device for circuit-breaker open/closed
- 7 Signalling device for closing spring charged/discharged
- 8 Operation counter.
- 9 Handles for operating the truck locks (only for withdrawable circuit-breakers)
- 10 Operating lever for circuit-breaker racking-in/out.

Fig. 6b

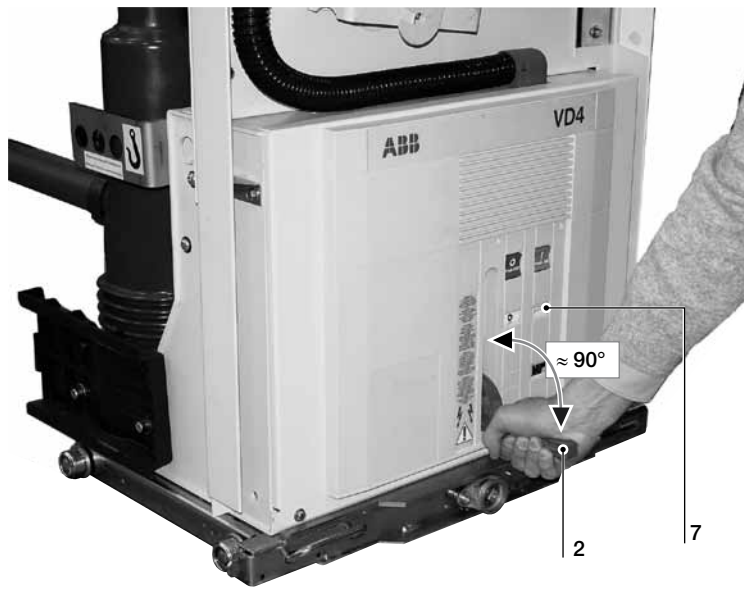

Fig. 7a

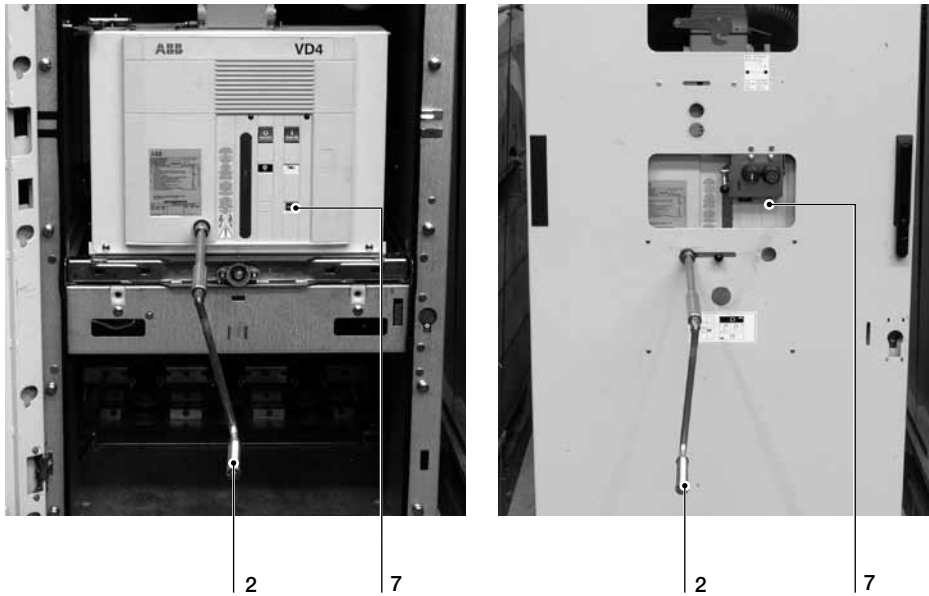

Fig. 7b

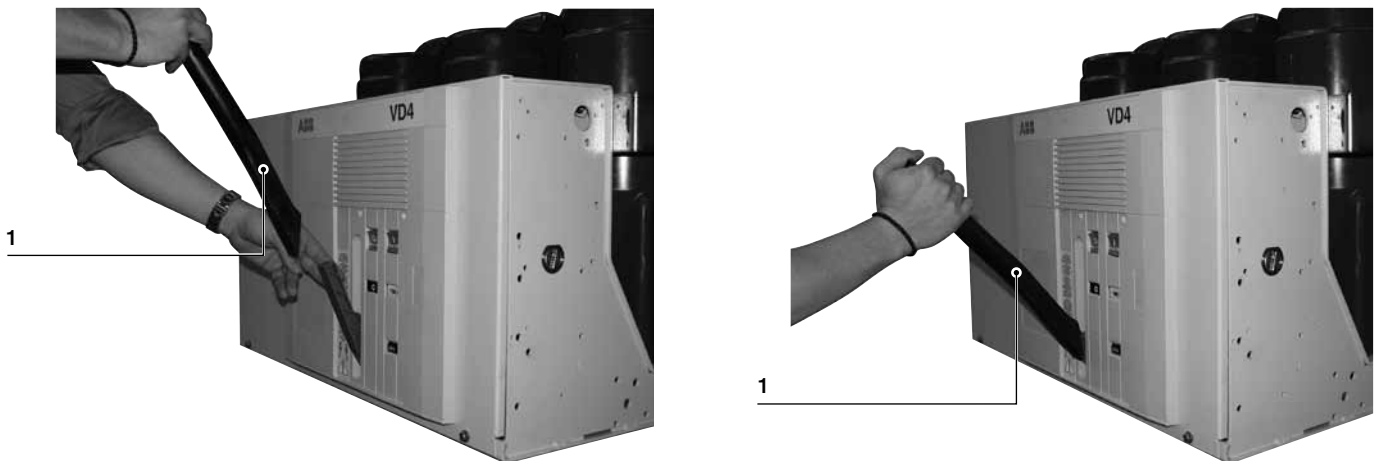

Fig. 7c

7. Installation

7.1. General

! Correct installation is of primary importance. The manufacturer's instructions must be carefully studied and followed. It is good practice to use gloves for handling the pieces during installation.

7.2. Installation and operating conditions

The following Standards must be taken into particular consideration during installation and service:

- IEC 62271-1/DIN VDE 0101
- VDE 0105: Electrical installation service
- DIN VDE 0141: Earthing systems for installations with rated voltage above 1 kV
- All the accident prevention regulations in force in the relative countries.

7.2.1. Normal conditions

Follow the recommendations in the IEC 62271-1 and 62271-100 Standards. In more detail:

Ambient temperature

Maximum	+ 40 °C
Average maximum over 24 hours	+ 35 °C
Minimum (according to class - 5), apparatus for indoor installation	- 5°

Humidity

The average value of the relative humidity, measured for a period longer than 24 hours, must not exceed the 95%.

The average value of the pressure of the water vapour, measured for a period longer than 24 hours, must not exceed 2.2 kPa.

The average value of the relative humidity, measured for a period longer than 1 month, must not exceed the 90%.

The average value of the pressure of the water vapour, measured for a period longer than 1 month, must not exceed 1.8 kPa.

Altitude

≤ 1000 m above sea level.

7.2.2. Special conditions

Installations over 1000 m a.s.l.

Possible within the limits permitted by reduction of the dielectric resistance of the air.

Increase in the ambient temperature

Reduction in the rated current.

Encourage heat dissipation with appropriate additional ventilation.

Climate

To avoid the risk of corrosion or other damage in areas:

- with a high level of humidity, and/or
- with rapid and big temperature variations, take appropriate steps (for example, by using suitable electric heaters) to prevent condensation phenomena.

For special installation requirements or other operating conditions, please contact ABB.

! The areas involved by the passage of power conductors or auxiliary circuit conductors must be protected against access of any animals which might cause damage or disservices.

7.2.3. Trip curves

The following graphs show the number of closing-opening cycles (No.) allowed, of the vacuum interrupters, according to the breaking capacity (Ia).

Caption (Figs. 8...)

No. Number of closing-opening cycles allowed for the vacuum interrupters.

Ia: Breaking capacity of the vacuum interrupters.

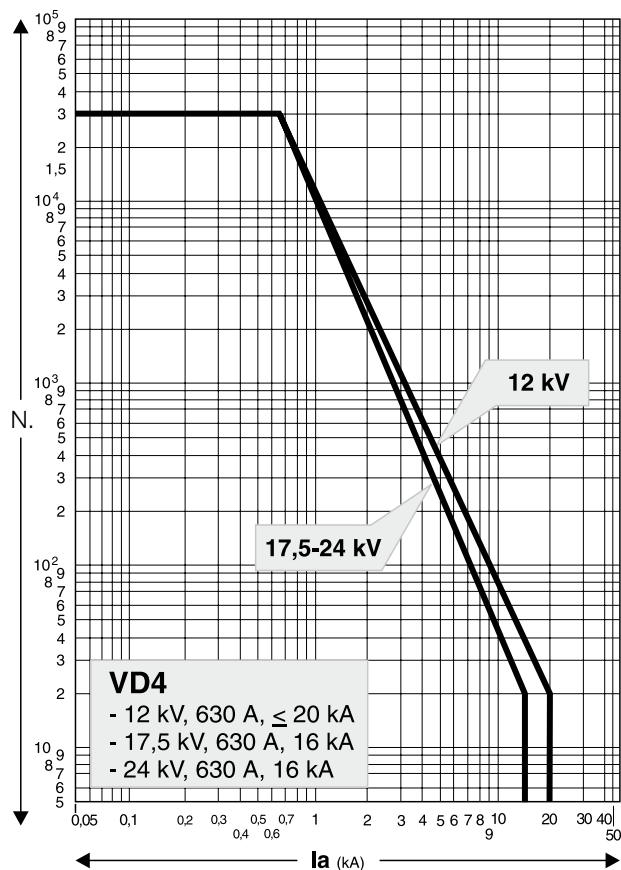

Fig. 8a

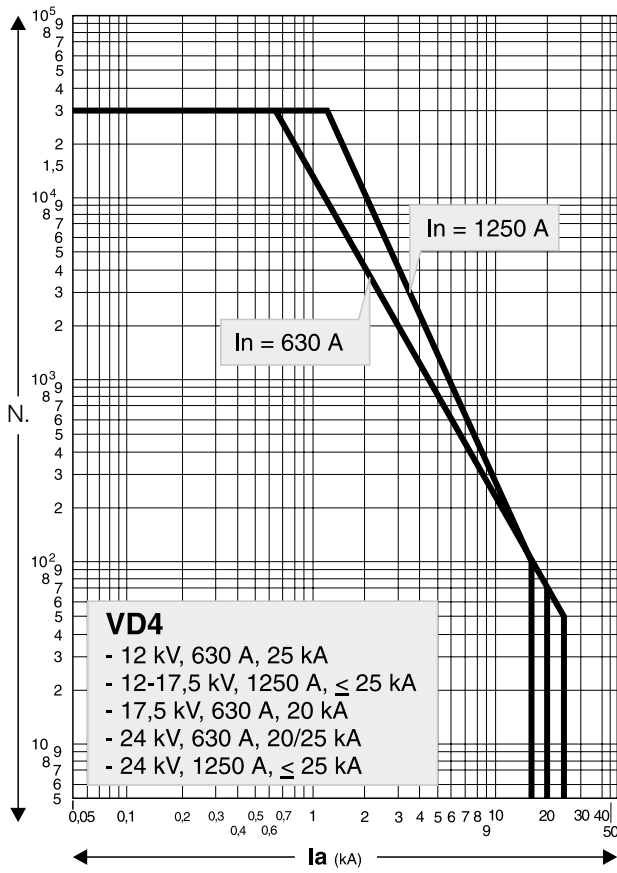

Fig. 8b

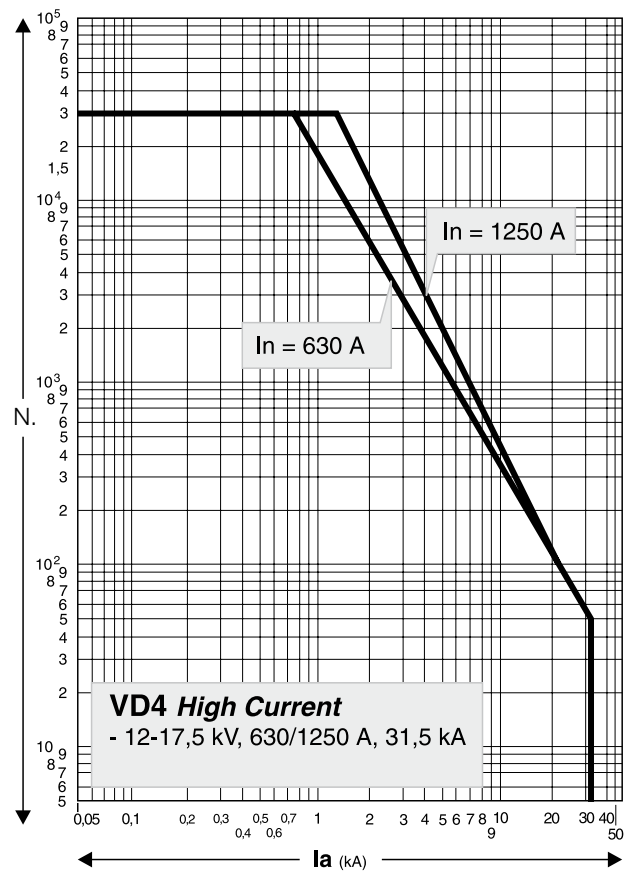

Fig. 8c

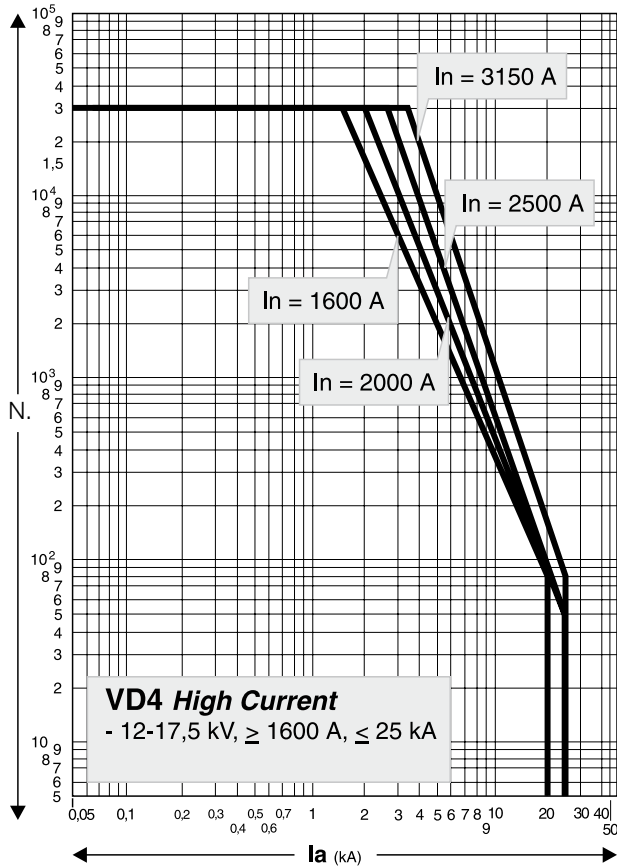

Fig. 8d

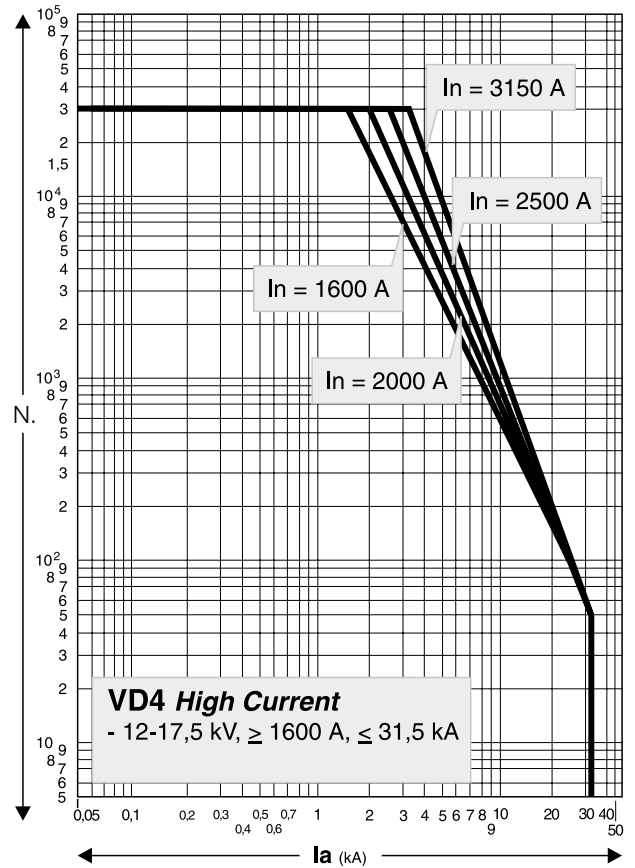

Fig. 8e

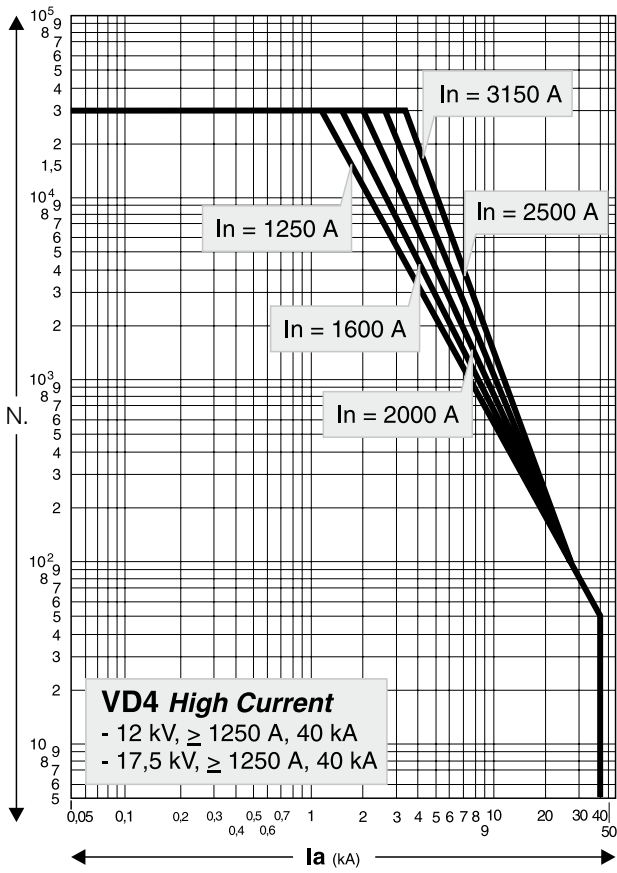

Fig. 8f

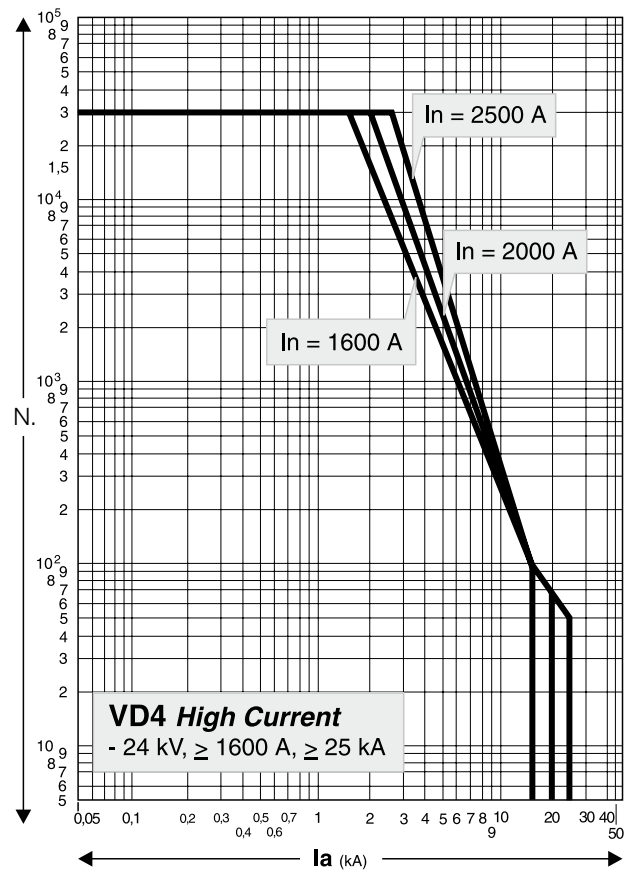

Fig. 8g

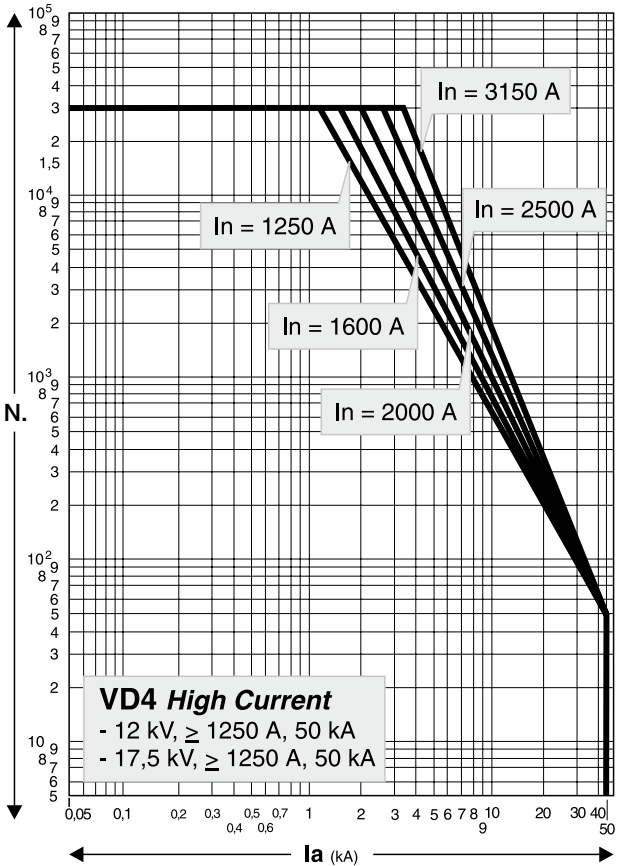

Fig. 8h

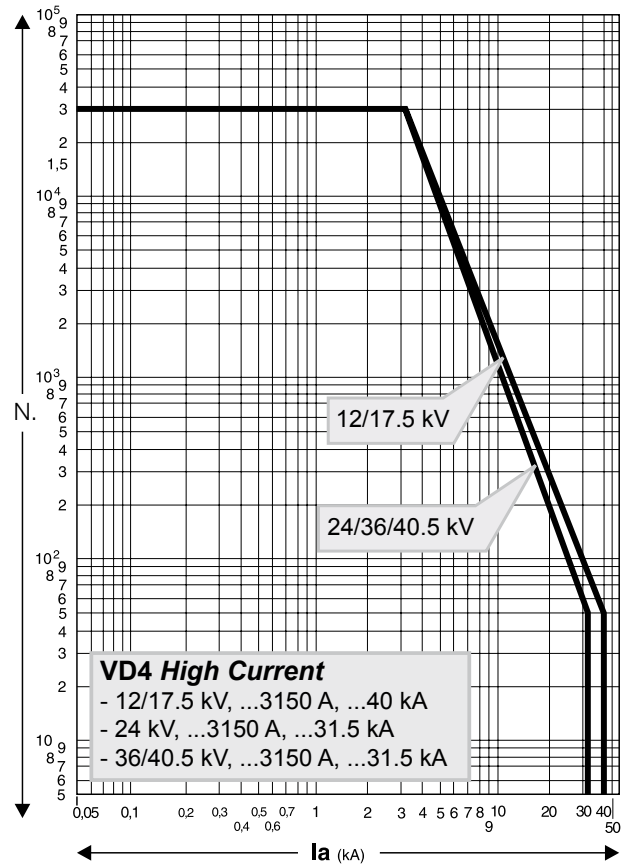

Fig. 8i

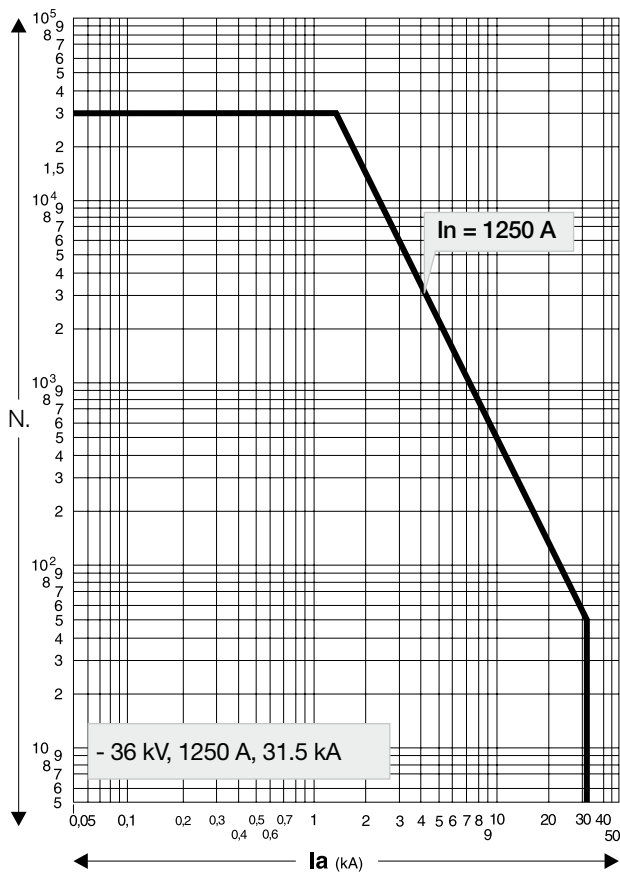

Fig. 8l

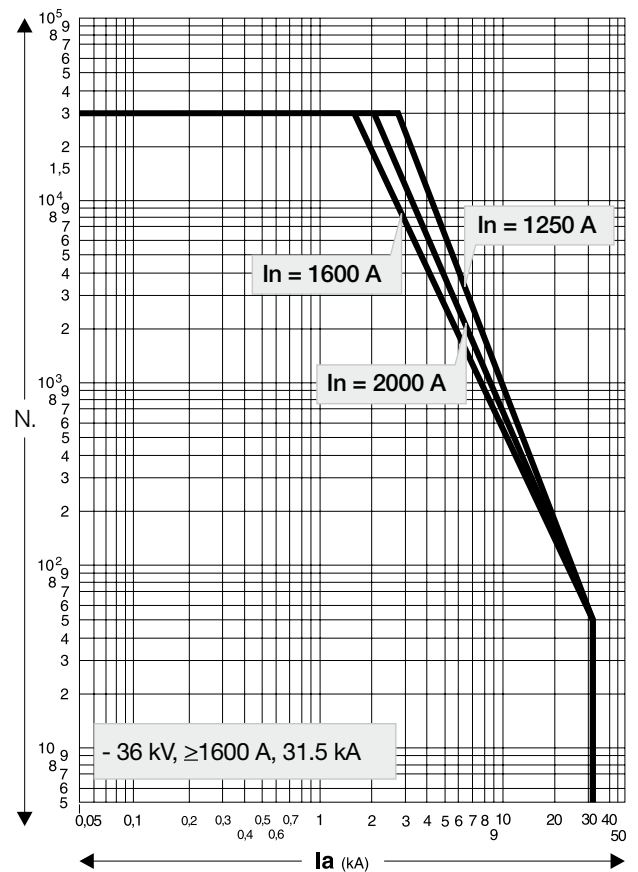

Fig. 8m

7.3. Preliminary operations

- Clean the insulating parts with clean dry cloths.
- Check that the top and bottom terminals are clean and free of any deformation caused by shocks received during transport or storage.

7.4. Installation of fixed circuit-breakers

The circuit-breaker can be mounted directly on supporting frames to be provided by the customer, or on a special supporting truck (available on request).

The circuit-breaker, with supporting truck, must be suitably fixed to the floor of its own compartment by the customer. The floor surface in correspondence with the truck wheels must be carefully levelled.

A minimum degree of protection (IP2X) must be guaranteed from the front towards live parts.

7.4.1. Mounting the circuit-breaker on a truck made by other manufacturers

The VD4 circuit-breakers which are not installed on ABB trucks, but on trucks made by the customer, must be fitted with one or two additional auxiliary contacts (activated by the

mechanical lock and by the circuit-breaker release device) to carry out the function of interrupting the shunt closing release circuit (-MC) during traverse from isolated and vice versa. In ABB trucks, this function is carried out by the -BT1 and -BT2 auxiliary contacts which cut off the release power supply during and before activation of the mechanical lock of the screw truck racking-in device. This means that the shunt closing release power supply can only be applied at the end of activation of the mechanical lock. In this way it is certain that no electrical impulse can activate the shunt closing release with the circuit-breaker in an intermediate position.

7.5. Installation of withdrawable circuit-breaker

The withdrawable circuit-breakers are preset for use in UniGear ZS1, UniGear ZS2, UniSec switchgear and PowerCube modules.

For racking-in/racking-out of the switchgear, fully insert the lever (1) (fig. 9) in the appropriate seat (2) and work it clockwise for racking-in, and anti-clockwise for racking-out, until the limit switch positions are reached.

Circuit-breaker racking-in/-out must be carried out gradually to avoid shocks which may deform the mechanical interlocks and the limit switches.

The torque normally required to carry out racking-in and racking-out is $\leq 25\text{ Nm}$.

This value must not be exceeded. If operations are prevented or difficult, do not force them and check that the operating sequence is correct.

Note

To complete the racking-in/out operation, about 20 rotations of the lever are required for circuit-breakers up to 17.5 kV, and about 30 rotations for 24 kV circuit-breakers.

When the circuit-breaker has reached the isolated for test/ isolated position, it can be considered racked into the switchgear and, at the same time, earthed by means of the truck wheels.

Withdrawable circuit-breakers of the same version, and therefore with the same dimensions, are interchangeable. However, when, for example, different electrical accessory fittings are provided, a different code for the plug of the auxiliary circuits does not allow incorrect combinations between panels and circuit-breakers.

For the circuit-breaker installation operations, also refer to the technical documentation of the above-mentioned switchgear.



- **The racking-in/-out operations must always be carried out with the circuit-breaker open.**
- **When putting into service for the first time, it is advisable to charge the circuit-breaker operating mechanisms manually so as not to overload the auxiliary power supply circuit.**

7.5.1. Circuit-breakers with withdrawable motorized truck

Carry out the racking-in/racking-out test of the motorized truck in the same way as for a manual truck, following the instructions below:

- Rack the circuit-breaker into the switchgear in the open and isolated position, with the power supply to the motor circuit cut off and with the enclosure door closed.

- Insert the manual racking-in lever (1) in the special coupling (2) Fig. 9, and take the motorized truck to about half its run between the isolated for test and the connected position. The torque needed to carry out truck handling is $\leq 25\text{ Nm}$. In the case of accidental inversion of the truck motor power supply polarity, this operation allows a possible error in direction to be dealt with without any damage. Verification checks:

- a) motor rotation **clockwise** during circuit-breaker racking-in.
- b) motor rotation **anticlockwise** during circuit-breaker racking-out.
- Remove the manual lever (1) from the coupling (2) Fig. 9
- Supply the truck motor circuit.
- Activate the control for the electrical racking-in operation. When racking-in has taken place, check correct changeover of the relative auxiliary contact.
- On completion, activate the control for the electrical racking-out operation. When racking-out has taken place, check correct changeover of the relative auxiliary contact.
- In the case of a motor fault during a racking-in or racking-out operation, in an emergency the truck can be taken to the end of its run manually, after first cutting off the power supply to the motor power supply circuit and then, using the manual lever, work in the same way as with the manual truck.

Note

By means of the chain transmission, truck handling carried out using the manual lever makes the truck motor armature rotate which, behaving like a generator, can cause inverse voltage at the connection terminals. This may damage the permanent magnet of the motor, therefore all the truck racking-in and racking-out operations carried out using the manual lever must be done without power supply in the motor circuit.

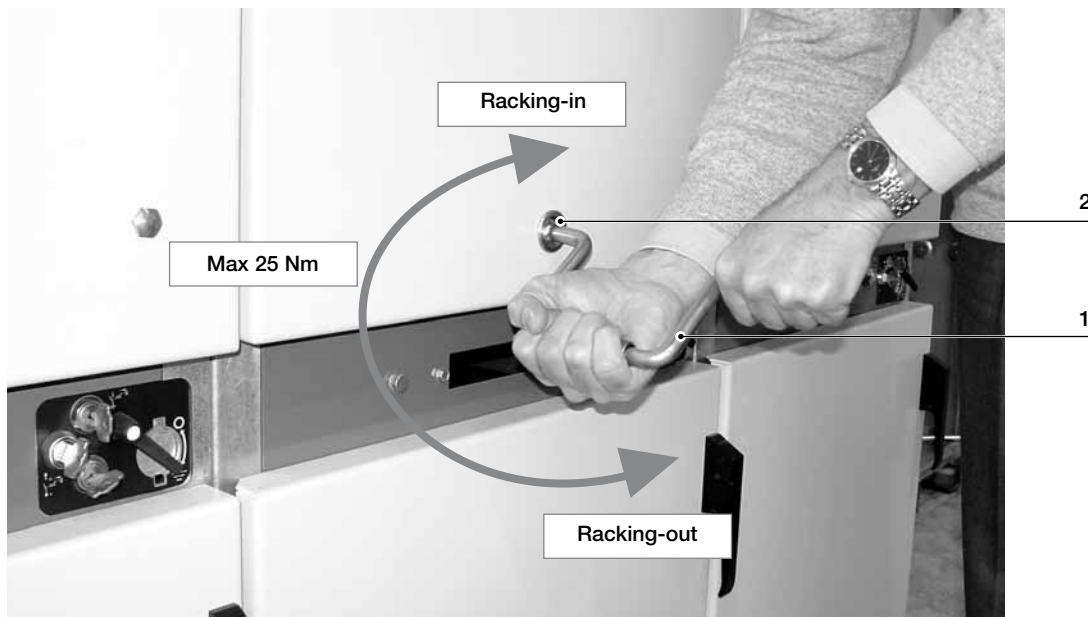

Fig. 9

7.6. Power circuit connections of fixed circuit-breakers

7.6.1. General recommendations

- Select the cross-section of the conductors according to the service current and the short-circuit current of the installation.
- Prepare special pole insulators, near the terminals of the fixed circuit-breaker or of the enclosure, sized according to the electrodynamic forces deriving from the short-circuit current of the installation.

7.6.2. Assembly of the connections

- Check that the contact surfaces of the connections are flat, and are free of any burrs, traces of oxidation or deformation caused by drilling or impacts received.
- According to the conductor material and the surface treatment used, carry out the operations indicated in table T1 on the contact surface of the conductor.

Assembly procedure

- Put the connections in contact with the circuit-breaker terminals, taking care to avoid mechanical stresses (traction / compression) on, for example, the conducting busbars on the terminals.
- Interpose a spring washer and a flat washer between the head of the bolt and the connection.
- It is advisable to use bolts according to DIN class 8.8 Standards, also referring to what is indicated in table T2.
- In the case of cable connections, strictly follow the manufacturer's instructions to make the terminals.

T1

Bare copper

- Clean with a fine file or emery cloth.
- Tighten fully and cover the contact surfaces with 5RX Moly type grease.

Copper or silver-plated aluminium

- Clean with a rough dry cloth.
- Only in the case of obstinate traces of oxidation, clean with a very fine grain emery cloth taking care not to remove the surface layer.
- If necessary, restore the surface treatment.

Bare aluminium

- Clean with a metal brush or emery cloth.
- Cover the contact surfaces again immediately with neutral grease.
- Insert the copper-aluminium bimetal with surfaces shined (copper side in contact with the terminal; aluminium side in contact with the connection) between the aluminium connection and the copper terminal.

T2

Bolt	Recommended tightening torque ⁽¹⁾	
	Without lubricant	With lubricant ⁽²⁾
M6	10 Nm	4.5 Nm
M8	30 Nm	10 Nm
M10	40 Nm	20 Nm
M12	70 Nm	40 Nm
M16	200 Nm	80 Nm

- (1) The nominal tightening torque is based on a friction coefficient of the thread of 0.14 (distributed value the thread is subjected to which, in some cases, is not negligible). The nominal tightening torque with lubricant is according to the DIN 43673 Standards.
- (2) Oil or grease. The thread and surfaces in contact with the lubricated heads. Take into account the deviations from the general Standards table (for example, for systems in contact or terminals) as foreseen in the specific technical documentation. The thread and surfaces in contact with the heads of bolts must be slightly oiled or greased, so as to obtain a correct nominal tightening torque.

7.7. Earthing

For the fixed version circuit-breaker, carry out earthing by means of the special screw marked with the relative symbol. Clean and degrease the area around the screw to a diameter of about 30 mm and, on completion of assembly, cover the joint again with Vaseline grease. Use a conductor (busbar or braid) with a cross-section conforming to the Standards in force.

7.8. Connection of the auxiliary circuits

Note: the minimum cross-section of the wires used for the auxiliary circuits must not be less than the one used for the internal cabling. Furthermore, they must be insulated for 3 kV of test.

7.8.1. Fixed circuit-breaker

Connection of the circuit-breaker auxiliary circuits must be made by means of the terminal box (1) (fig. 10) mounted inside the circuit-breaker and the cables must pass through the connector (2). Outside the connector, the cables must pass through a suitable metal protective cover (pipe, wiring duct, etc.), which must be earthed.

To prevent the cabling wires outside the circuit-breaker (carried out by the customer) from accidentally coming into contact with moving parts and therefore undergoing damage to the insulation, it is recommended to fix the wires as shown in fig. 10a.



Before removing the operating mechanism cover to access the terminal box, check that the circuit-breaker is open and the closing spring discharged.

7.8.2. Withdrawable circuit-breakers

The auxiliary circuits of withdrawable circuit-breakers are fully cabled in the factory as far as the connector (fig. 11). For the external connections, refer to the electric wiring diagram of the switchgear.

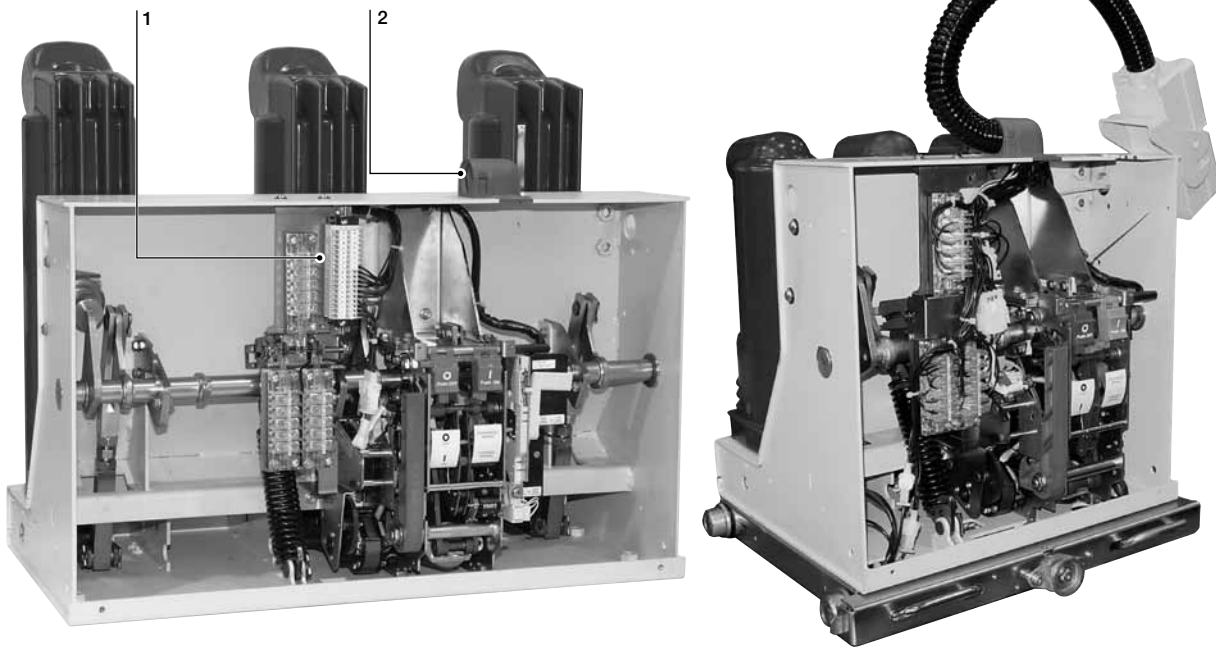

Fig. 10

VD4 circuit-breaker for ZS8.4 switchgear (VD4/ZS8 version with rotary charging).

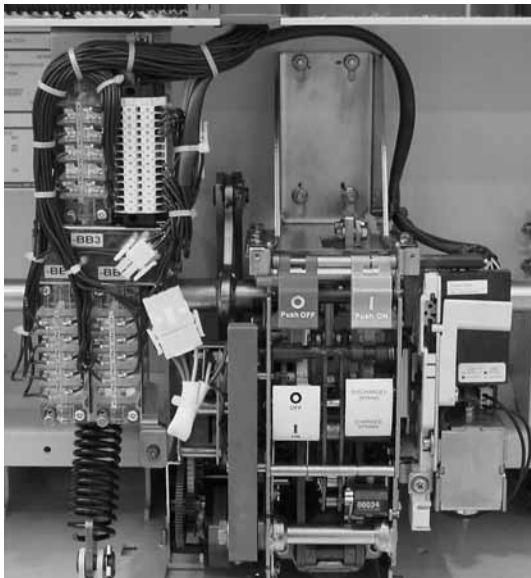

Fig. 10a

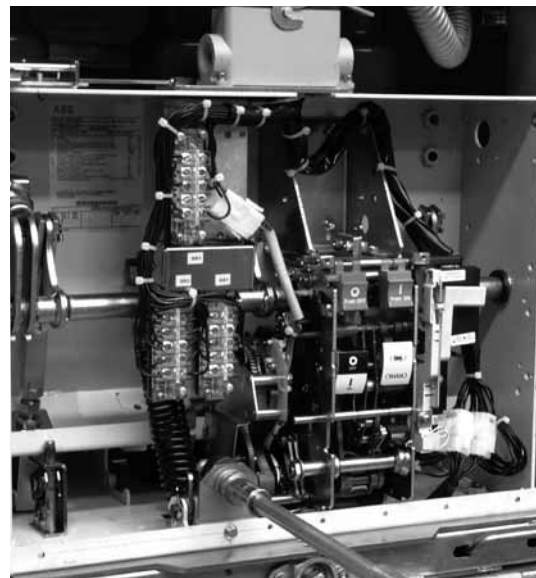

Fig. 11

8. Putting into service

8.1. General procedures



All the operations regarding putting into service must be carried out by ABB personnel or by suitably qualified customer personnel with in-depth knowledge of the apparatus and of the installation. Should the operations be prevented, do not force the mechanical interlocks and check that the operating sequence is correct. The operating forces which can be applied for racking-in withdrawable circuit-breakers are indicated in paragraph 7.5.

Before putting the circuit-breaker into service, carry out the following operations:

- check tightness of the power connections to the circuit-breaker terminals;
- establish the setting of the primary electronic overcurrent release (if provided);
- check that the value of the power supply voltage of the auxiliary circuits is between 85% and 110% of the rated voltage of the electrical accessories;
- check that no foreign bodies, such as bits of packing, have got into the moving parts;
- check that there is a sufficient exchange of air in the installation place to avoid overtemperatures;
- also carry out the checks indicated in table T3.

ITEM INSPECTED	PROCEDURE	POSITIVE CHECK
1 Insulation resistance.	<p>Medium voltage circuit</p> <p>With a 2500 V megger, measure the insulation resistance between the phases and the exposed conductive part of the circuit.</p>	The insulation resistance should be at least 50 Mohm and in any case constant over time.
	<p>Auxiliary circuits</p> <p>With a 500 V megger (if the apparatus installed allows this), measure the insulation resistance between the auxiliary circuits and the exposed conductive part.</p>	The insulation resistance should be a few Mohm and in any case constant over time.
2 Auxiliary circuits.	Check that the connections to the control circuit are correct: proceed at the relative power supply.	Operations and signals normal.
3 Manual operating mechanism.	Carry out a few closing and opening operations (see cap. 6). N.B. Supply the undervoltage release and the locking magnet on the operating mechanism at the relative rated voltage (if provided).	The operations and relative signals take place normally.
4 Motor operator (if provided).	Supply the spring charging geared motor at the relative rated voltage.	The spring is charged normally. The signals are normal. With the spring charged, the geared motor stops.
	Carry out a few closing and opening operations. N.B. Supply the undervoltage release and the locking magnet on the operating mechanism at the relative rated voltage (if provided).	The geared motor recharges the spring after each closing operation.
5 Undervoltage release (if provided).	Supply the undervoltage release at the relative rated voltage and carry out the circuit-breaker closing operation.	The circuit-breaker closes normally. The signals are normal.
	Cut off power to the release.	The circuit-breaker opens. The signalling changes over.
6 Shunt opening release and additional shunt opening release (if provided).	Close the circuit-breaker and supply the shunt opening release at the relative rated voltage.	The circuit-breaker opens normally. The signals are normal.
7 Shunt closing release (if provided).	Open the circuit-breaker and supply the shunt closing release at the relative rated voltage.	The circuit-breaker opens normally. The signals are normal.
8 Key lock (if provided).	Open the circuit-breaker, keep the opening pushbutton depressed, then turn the key and remove it from the housing. Attempt the circuit-breaker closing operation.	Neither manual nor electrical closing takes place.
	Put the key back in and turn it 90°. Carry out the closing operation.	Both electrical and manual closing take place normally; in this position the key cannot be removed.
9 Locking electromagnet (-RL1) (if provided).	With the circuit-breaker open, spring charged and locking electromagnet not supplied, attempt circuit-breaker closing both manually and electrically.	Closing is not possible.
10 Auxiliary contacts in the operating mechanism.	Insert the auxiliary contacts in suitable signalling circuits. Carry out a few closing and opening operations.	Signals take place normally.
11 Locking electromagnet on the truck circuit-breaker (-RL2) (if provided).	With the circuit-breaker open, in the isolated for test position and the locking electromagnet not supplied, attempt racking-in of the circuit-breaker.	Racking-in is not possible.
	Supply the locking electromagnet and carry out the racking-in operation.	Racking-in takes place correctly.
12 Auxiliary transmitted contacts for signalling circuit-breaker racked-in, isolated (UniGear switchgear or PowerCube modules).	Insert the auxiliary contacts in suitable signalling circuits. With the circuit-breaker racked into the enclosure, carry out a few traverse operations from the isolated for test position to the connected position. Take the circuit-breaker to the racked-out position.	The signals due to the relative operations take place normally.

9. Maintenance

The maintenance operations are aimed at keeping the apparatus in good working condition for as long as possible. In accordance with what is specified in the IEC 61208 / DIN 31 051 Standards, the following operations must be carried out.

Inspection:	Finding out the actual conditions
Overhauling:	Measures to be taken to maintain the specific conditions
Repairs:	Measures to be taken to restore the specific conditions.

9.1. General

The vacuum circuit-breakers are characterised by simple, sturdy construction and a long life.

The operating mechanism requires maintenance and functional inspections to reach the expected operating-life (see par. 9.3.2.).

The vacuum interrupters are maintenance-free for their whole operating life.

Vacuum interruption does not produce any harmful effects even when there are frequent interruptions at the rated and short-circuit current.

The interventions during service and their aim are determined by the ambient conditions, by the sequence of operations and by the short-circuit interruptions.

Note

Respect the following Standards for maintenance work:

- the relative specifications given in the chapter on “Standards and Specifications”;
- work safety regulations in the chapter on “Putting into service and operations”;
- standards and specifications of the country where the apparatus is installed.

The maintenance operations must only be carried out by trained personnel and who follow all the safety regulations. Furthermore, it is advisable to call on ABB personnel, at least in cases for checking the performances in service and for repairs.

Cut the power supply off and put the apparatus under safe conditions during the maintenance operations.



Before carrying out any operations, check that the circuit-breaker is open, with the spring discharged and that it is not supplied (medium voltage circuit and auxiliary circuits).

9.1.1. Operating life expectancy

The operating life expectancy for the VD4 circuit-breakers is as follows:

- vacuum interrupters: up to 30,000 operations, according to their type (see par. 7.2.3. Trip curves);

- switching device, actuator and transmission system: up to 30,000 operations, under normal operating conditions, according to the type of circuit-breaker and with regular maintenance (see par. 9.3.2.);
- with operations correctly executed it is possible to carry out up to 1000 racking-out/in operations (as prescribed in the IEC 60271-200 Standards);
- the data regarding the operating life are basically applicable to all the components which cannot be directly affected by operator activity. The manually operated components (moving parts of isolatable parts, etc.) can vary their behaviour.

9.2. Inspections and functionality tests

9.2.1. Interruption devices in general

- Check the conditions of the interruption devices with regular inspections.
- Inspection at fixed intervals can be avoided when the apparatus is permanently under the control of qualified personnel.
- The checks must, first of all, include visual inspection to check for any contamination, traces of corrosion or electrical discharge phenomena.
- Carry out more frequent inspections when there are unusual operating conditions (including severe climatic conditions) and in the case of environmental pollution (e.g. high level of contamination or an atmosphere with aggressive agents).
- Visual inspection of the isolating contacts.
It is recommended to turn the contact system alternately in order to keep the internal surface of the contact areas clean. The contact areas must be cleaned when there are signs of overheating (discoloured surface) (also see Repairs).
- In the case of abnormal conditions, take suitable overhauling measures (see Overhauling par.).

9.2.2. Stored energy operating mechanism

Carry out the functional test of the operating mechanism after 5,000 operations (2,000 operations for 3150 A circuit-breakers) or during ordinary maintenance operations as specified in par. 9.2.1.

Before doing the test, open the circuit-breaker and carry out the following operations:

- in the case of withdrawable circuit-breakers, take the circuit-breaker to the isolated for test position
- in the case of fixed circuit-breakers: cut off the power supply to the medium voltage circuit.

Note

Insulate the work area and make it safe, following the safety regulations specified in the IEC/DIN VDE Standards.

Functional test

- With the circuit-breaker not connected to the load, carry out a few opening and closing operations.
- If foreseen, cut the power supply to the spring charging motor off. Discharge the spring by closing and opening the circuit-breaker by means of the closing and opening pushbuttons.
- Visually inspect the lubrication conditions of the tulip isolating contacts, of the sliding surfaces, etc.

- Check correct electrical and mechanical operation of the various devices, with particular attention to the interlocks.
- The screws and nuts are tightened in the factory and correct tightening is marked with a collared sign. No further tightening operations are foreseen during the operating life of the circuit-breaker. However, following any maintenance interventions, should it be necessary to re-tighten the screws or nuts, it is recommended to always replace the screws and nuts and to keep to the values indicated in fig. 12.

Checking tightness of the screws

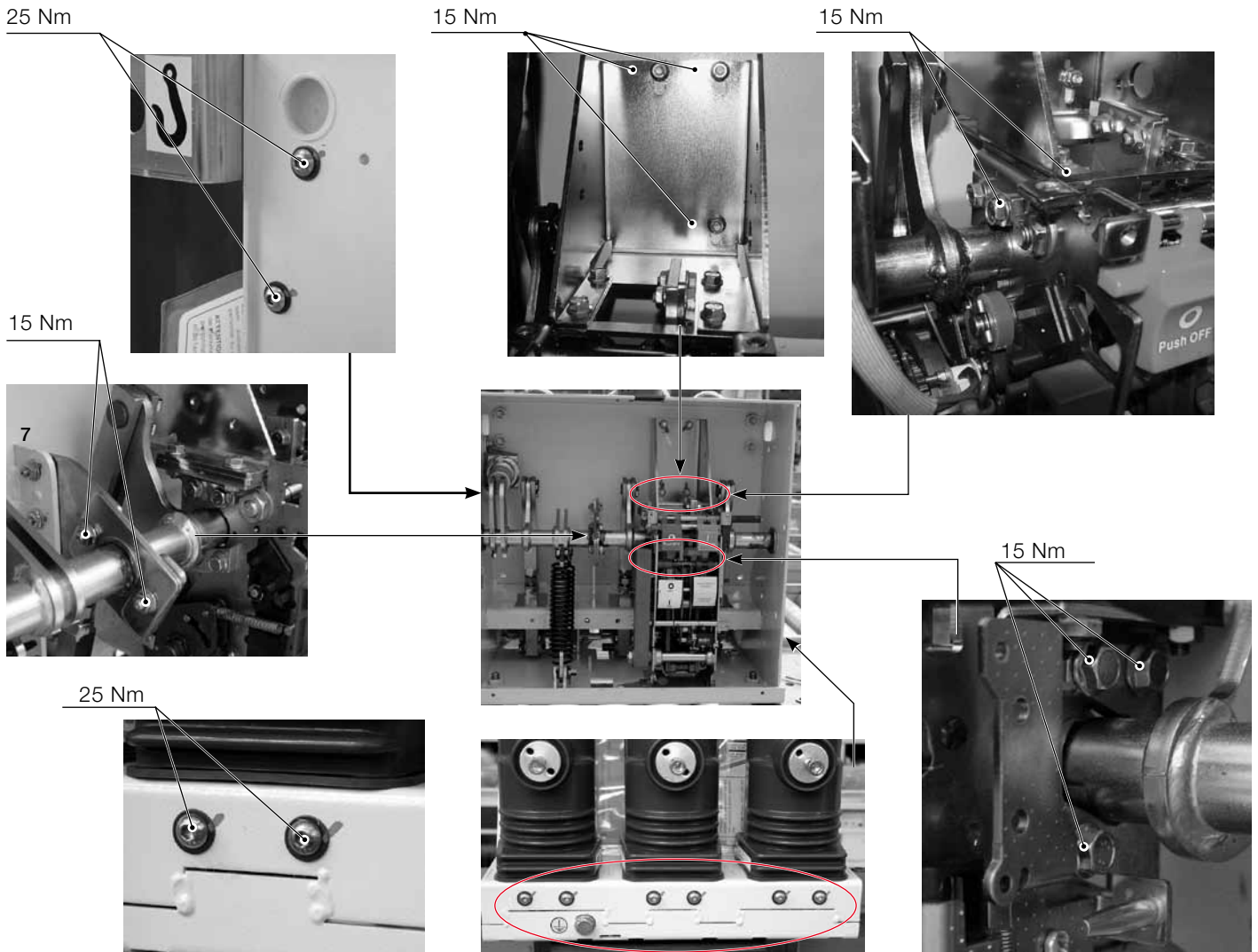

EL Twin actuator - 50 kA

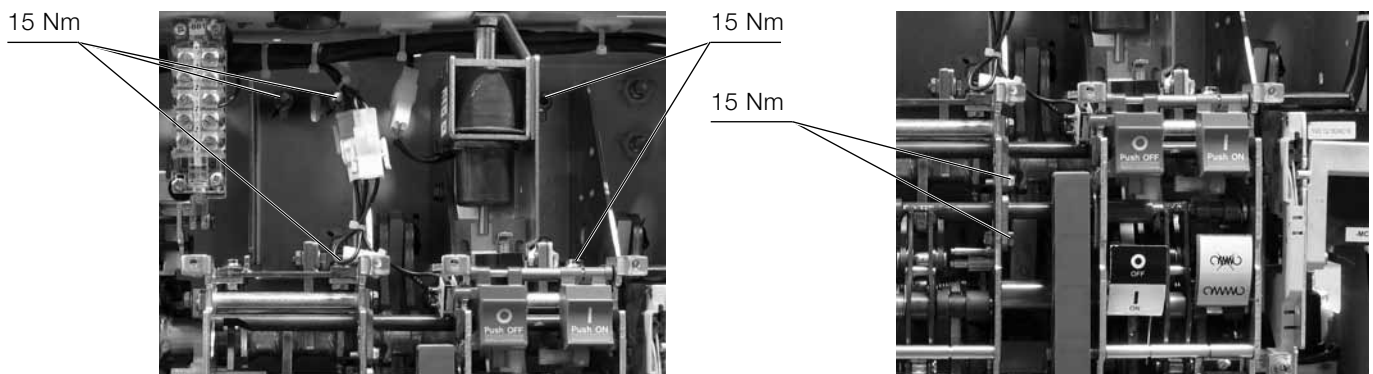

Fig. 12

9.2.3. Circuit-breaker pole

No other check except what has already been specified in par. 9.2.1. is necessary.

9.2.4. Withdrawable assembly (truck and circuit-breaker)

Visually inspect the components, especially those which may be damaged by incorrect operations (also see table in chap. 8). Visually inspect the isolating contacts and that all the contact elements are clean, especially in cases where signs of overheating are found (also see par. 9.4.).

Visually inspect and carry out the functional tests of the locks, checking their correct operation and activation without abnormal force – maximum 25 N (also see table in chap. 8).

9.3. Overhauling

9.3.1. Interruption devices in general

Should it have been necessary to clean the devices during the inspections, according to what is specified in par. 9.2.1., use the following procedure:

- insulate the work area and make it safe, following the safety regulations specified in the IEC/DIN VDE Standards;
- general cleaning of the surfaces:
 - dry and eliminate light deposits of dirt with a soft dry cloth;
 - more resistant deposits of dirt can be removed using slightly alkaline domestic type detergent or Rivolta BWR 210 type detergent;
- cleaning insulating surfaces and conductive parts:
 - light dirt: with Rivolta BWR 210 detergent;
 - resistant dirt: with cold detergent type 716.

After cleaning, rinse thoroughly with clean water and dry carefully.

Note

Only use detergents without halogens and never 1.1.1-trichloroethane, trichloroethylene or carbon tetrachloride!

9.3.2. Tripping device: actuator and transmission system

Circuit-breakers up to 17.5 kV, 2500 A, 31.5 kA and up to 24 kV, 2500 A, 25 kA

To ensure correct operation of the circuit-breaker, inspection and maintenance of the tripping devices is recommended every 10,000 operations. For this purpose, please contact the ABB Service office.

Complete replacement of the actuator, shock absorber and of the other transmission system parts (shaft, main levers, safety rings, etc.) must be carried out after 30,000 operations.

Circuit-breakers up to 17.5 kV, 40 kA and 24 kV, 31.5 kA

To ensure correct operation of the circuit-breaker, inspection and maintenance of the tripping devices is recommended every 10,000 operations. For this purpose, please contact the ABB Service office.

Complete replacement of the actuator must be carried out every 10,000 operations.

Complete replacement of the shock absorber and of the other transmission system parts (shaft, main levers, safety rings, etc.) must be carried out after 30,000 operations.

Replacement of spring charging geared motor (if provided) must be carried out every 3,000 operations.

Circuit-breakers up to 17.5 kV, 3150 A, 40 kA

To ensure correct operation of the circuit-breaker, inspection and maintenance of the tripping devices must be carried out every 2,000 operations. For this purpose, please contact the ABB Service office.

Complete replacement of the shock absorber and of the other part of the transmission system (shaft, main levers, safety rings, etc.) must be carried out after 10,000 operations.

Replacement of spring charging geared motor (if provided) must be carried out every 3,000 operations.

Circuit-breakers up to 17.5 kV, 50 kA and EL twin actuator

To ensure correct operation of the circuit-breaker, inspection and maintenance of the tripping devices must be carried out every 10,000 operations. For this purpose, please contact ABB Service.

Complete replacement of the shock-absorber and of the other parts of the transmission system (shaft, main levers, safety rings, etc.) must be carried out every 10,000 operations.

Replacement of spring charging geared motor (if provided) must be carried out every 2,000 operations.

Note

Dismantling and replacement of the operating mechanism (trip box) can only be carried out by ABB personnel or by skilled and specially trained personnel, particularly for the necessary adjustments.

Details regarding overhauling

- When foreseen, cut of the power supply to the spring charging motor and manually discharge the operating mechanism spring by closing and opening the circuit-breaker.
- Replace the parts subjected to mechanical stress or stress due to particular environmental conditions, (contact and ABB service centre).

Note

These operations can only be carried out by ABB personnel or by skilled and specially trained personnel.

9.3.3. Circuit-breaker pole

The circuit-breaker pole and relative vacuum interrupter are maintenance-free until the maximum number of electrical operations for the type of interrupter is reached (see par. 7.2.3. Trip curves).

The operating life of the vacuum interrupter is defined by the sum of the ultimate currents corresponding to the specific type of interrupter in accordance with what is indicated in the graphs of par. 7.2.3. Trip curves: when the sum of the ultimate currents is reached, the whole pole must be replaced.

Note

Dismantling and replacement of the pole can only be carried out by ABB personnel or by skilled and specially trained personnel, particularly for the necessary adjustments.

To carry out the interrupter test without dismantling the circuit-breaker pole, use:

- the VIDAR vacuum tester, made by the company Programma Electric GmbH, Bad Homburg v.d.H.

To check vacuum tightness of the interrupter, the following test values must be set on the VIDAR tester:

Rated voltage of the circuit-breaker	d.c. test voltage
12 kV	40 kV
17.5 kV	40 kV
24 kV - 36 kV	60 kV

The test must always be carried out with the circuit-breaker open with the contacts at the nominal distance.

Procedure for testing the degree of vacuum of the interrupter of the circuit-breaker poles:

- turn the power supply off and make the working area safe by following the safety regulations specified in the IEC/DIN VDE Standards;
- open the circuit-breaker;
- earth a terminal of each circuit-breaker pole;
- connect the earth terminal of the VIDAR tester to the circuit-breaker structure;
- connect the high voltage terminal of the VIDAR tester to the terminal of the circuit-breaker pole not connected to earth (L1 phase) and carry out the test. Repeat the test for phases L2 and L3.

Note

The tester connection cables can produce an indication due to the capacitive effect. In this case the cables must not be removed.

9.4. Repairs

Replacement of spare parts and accessories must only be carried out by ABB personnel or suitably qualified and specially trained personnel.

Always work with the circuit-breaker open and locked so that it cannot be closed again, with the work area insulated and made safe.

The operating mechanism spring must be discharged.

All power supply sources must be disconnected and made safe against any reclosing during removal and installation work.



Should maintenance be carried out by the customer's personnel, responsibility for the interventions remains with the customer.

The replacement of parts not included in the "List of spare parts/accessories" (par. 12.1.) must only be carried out by ABB personnel. In particular:

- complete pole with bushings/connections
- actuator and transmission system
- closing spring set
- opening spring
- shock-absorber.

10. Application of the X-ray emission Standards

One of the physical properties of vacuum insulation is the possibility of X-ray emission when the interrupter contacts are open.

The specific tests carried out at the PTB laboratories (Physikalisch-Technische Bundesanstalt, in Brunswick - Germany) show that local emission at a distance of 10 cm from the interrupter or pole surface, does not exceed 1 mSv/h.

It follows that:

- at the rated service voltage the use of vacuum interrupters is absolutely safe;
- application of the withstand voltage at power frequency, according to the IEC 62271-100 and VDE 0670 Standards, is safe;
- application of a voltage higher than the withstand voltage at power frequency or of a test voltage in direct current, specified in the IEC and VDE Standards, cannot be used;
- limitation of the above-mentioned local phenomena, with interrupters with open contacts, depends on keeping the specific distance between the contacts.
This condition is intrinsically guaranteed by correct operation of the operating mechanism and by the adjustments of the transmission system.

11. Spare parts and accessories



All assembly operations of spare parts/accessories must be carried out following the instructions enclosed with the spare parts, by ABB personnel or by suitably qualified customer personnel with in-depth knowledge of the apparatus (IEC 60694) and of all the Standards aimed at carrying out these interventions in safe conditions. Should the maintenance be carried out by the customer's personnel, responsibility for the interventions remains with the customer. Before carrying out any operation, always make sure that the circuit-breaker is open, the spring discharged and that it is not energised (medium voltage circuit and auxiliary circuits).

To order circuit-breaker spare parts/accessories, refer to the ordering sales codes indicated in the technical catalogue and always state the following:

- type of circuit-breaker
- rated voltage of the circuit-breaker
- rated normal current of the circuit-breaker
- breaking capacity of the circuit-breaker
- serial number of the circuit-breaker
- rated voltage of any electrical spare parts.

For availability and to order spare parts, please contact our Service office.

11.1. List of spare parts

- Shunt opening release
- Additional shunt opening release
- Undervoltage release
- Contact for signalling undervoltage release energised/de-energised
- Time delay device for undervoltage release
- Mechanical override for undervoltage release
- Shunt closing release
- Spring charging geared motor with electrical signalling of spring charged
- Contact signalling protection circuit-breaker of the geared motor open/closed
- Contact signalling closing spring charged/discharged
- Transient contact with momentary closing during circuit-breaker opening
- Circuit-breaker auxiliary contacts
- Locking electromagnet on the operating mechanism
- Position contact of the withdrawable truck
- Contacts signalling connected/isolated
- Opening solenoid
- Key lock in open position
- Isolation interlock with the door
- Protection for opening pushbutton
- Protection for closing pushbutton
- Locking electromagnet on the withdrawable truck
- Set of six tulip contacts.

12. Electric circuit diagrams

The standard VD4 circuit-breaker electric circuit diagrams are as follows:

- 1VCD400046: Fixed circuit-breakers
- 1VCD400099: Fixed circuit-breakers 50 kA
- 1VCD400055: Fixed circuit-breakers with 64-pole connector
- 1VCD400064: Fixed circuit-breakers with 58-pole connector
- 1VCD400078: Fixed circuit-breakers with truck
- 1VCD400047: Withdrawable circuit-breakers
- 1VCD400048: Withdrawable circuit-breakers with motorized truck
- 1VCD400100: Withdrawable circuit-breakers 50 kA
- 1VCD400080: Withdrawable circuit-breakers for ZS8.4 switchgear VD4/ZS8, ZT8 and Z8 with circuit-breaker
- 1VCD400080: Withdrawable circuit-breakers for ZS8.4 switchgear with VD4/ZS8, ZT8 and Z8 circuit-breaker with motorized truck
- 1VCD400102: Withdrawable circuit-breakers with motorized truck 50 kA.

Each circuit-breaker is always provided with the standard electric diagram or with a specific diagram in the case of a circuit-breaker with non-standard cabling.

13. Overall dimensions

Fixed circuit-breakers

VD4	
TN	1VCD000050
Ur	12 kV
	17.5 kV
Ir	1600 A
Isc	20 kA
	31.5 kA

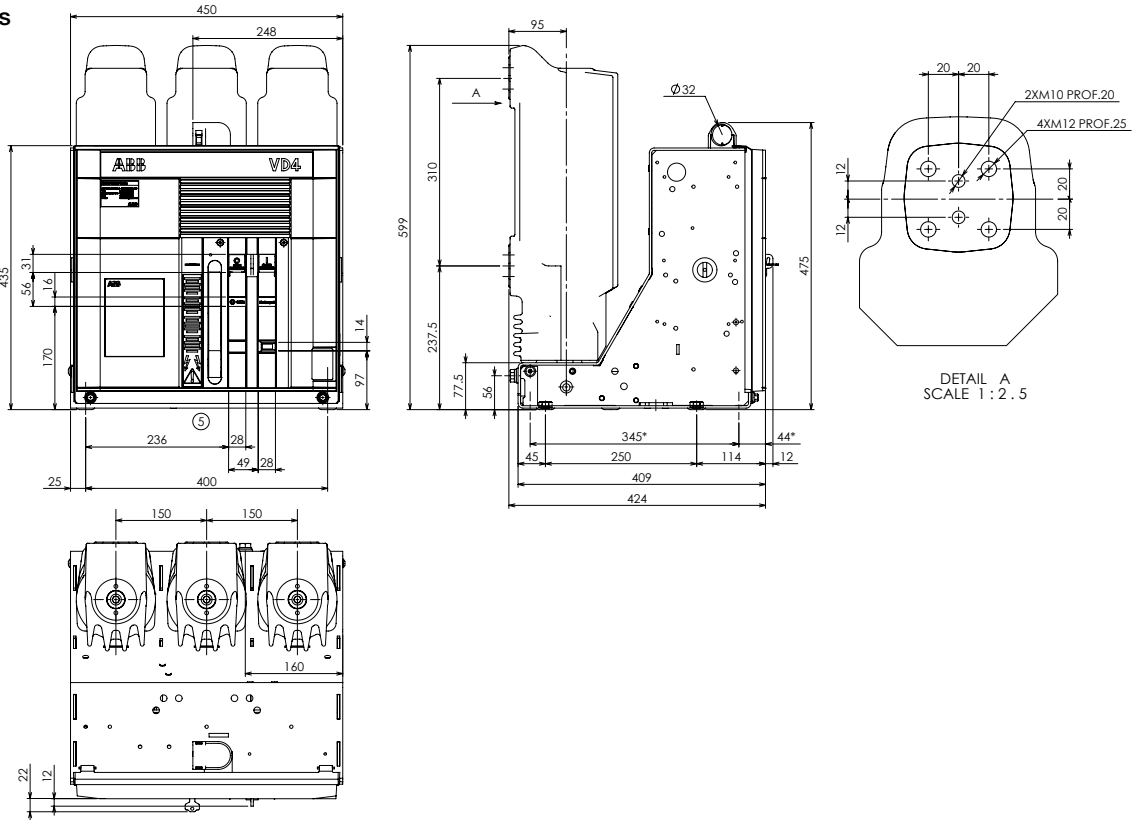

(*) Fixing interchangeability with previous series (345 x 400).

Fixed circuit-breakers

VD4	
TN	7405
Ur	12 kV
	17.5 kV
Ir	630 A
	1250 A
Isc	16 kA
	20 kA
	25 kA
	31.5 kA

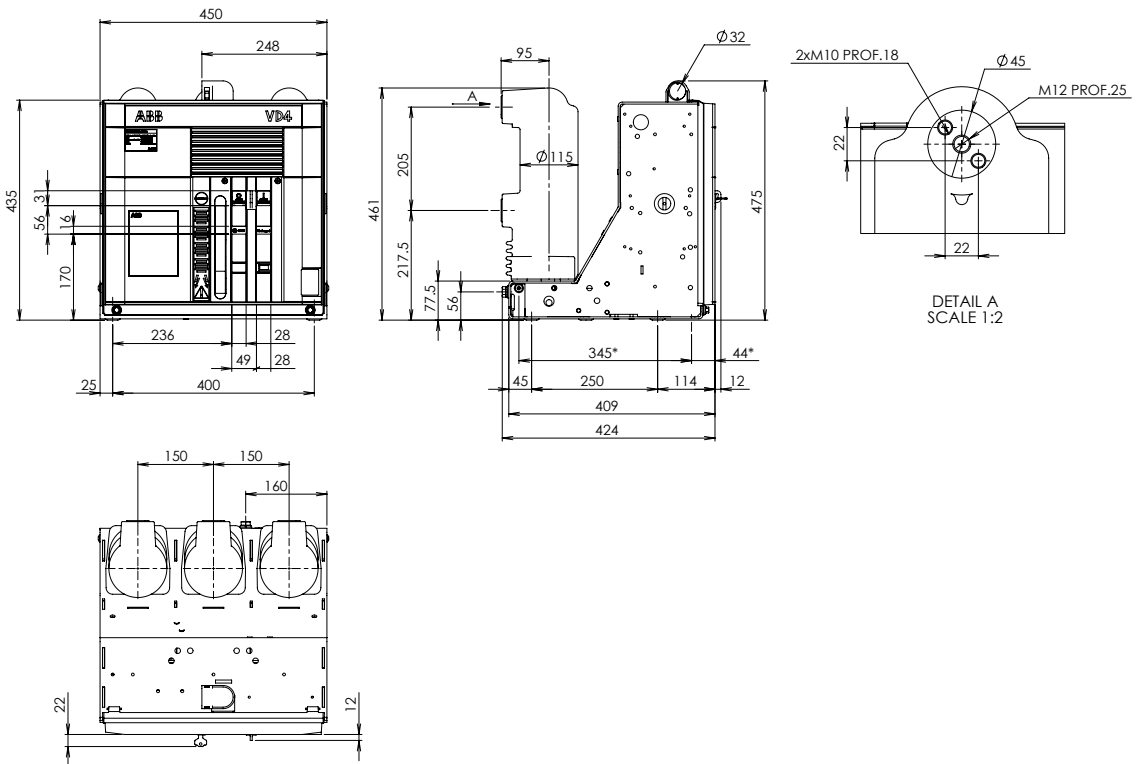

(*) Fixing interchangeability with previous series (345 x 400).

Fixed circuit-breakers

VD4	
TN	7406
Ur	12 kV
	17.5 kV
Ir	630 A
	1250 A
	16 kA
Isc	20 kA
	25 kA
	31.5 kA

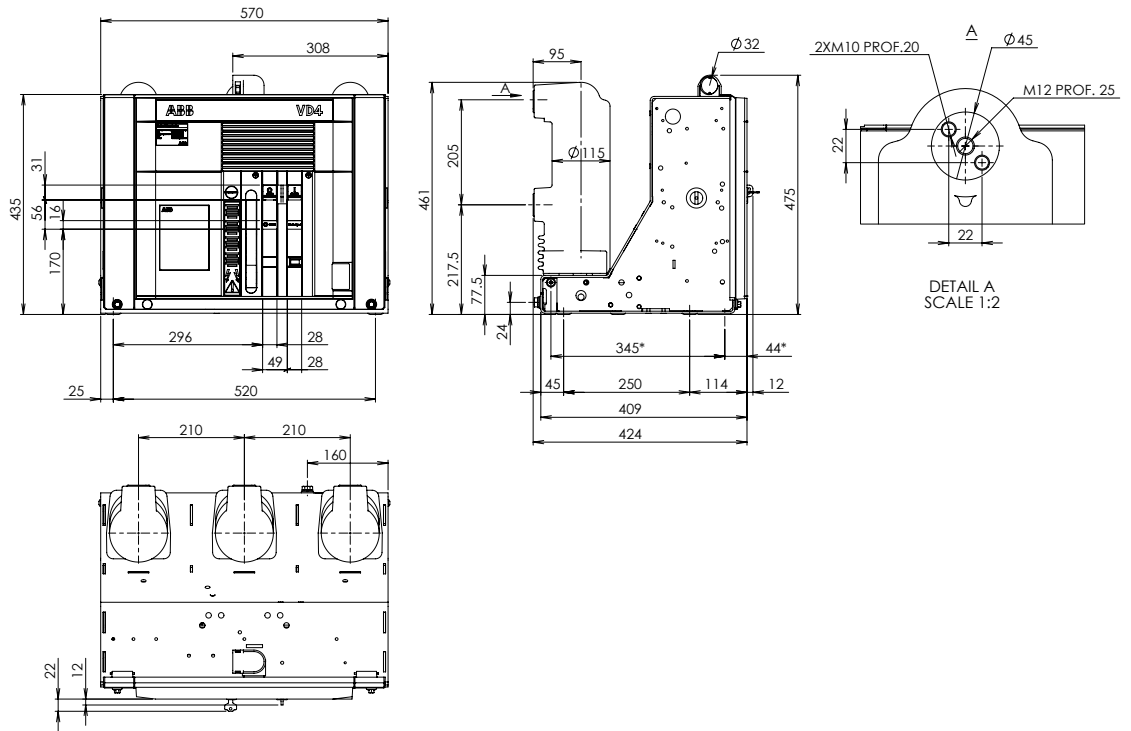

(*) Fixing interchangeability with previous series (345 x 520).

Fixed circuit-breakers

VD4	
TN	1VCD003282
Ur	12 kV
	17.5 kV
Ir	1250 A
	1600 A
Isc	40 kA

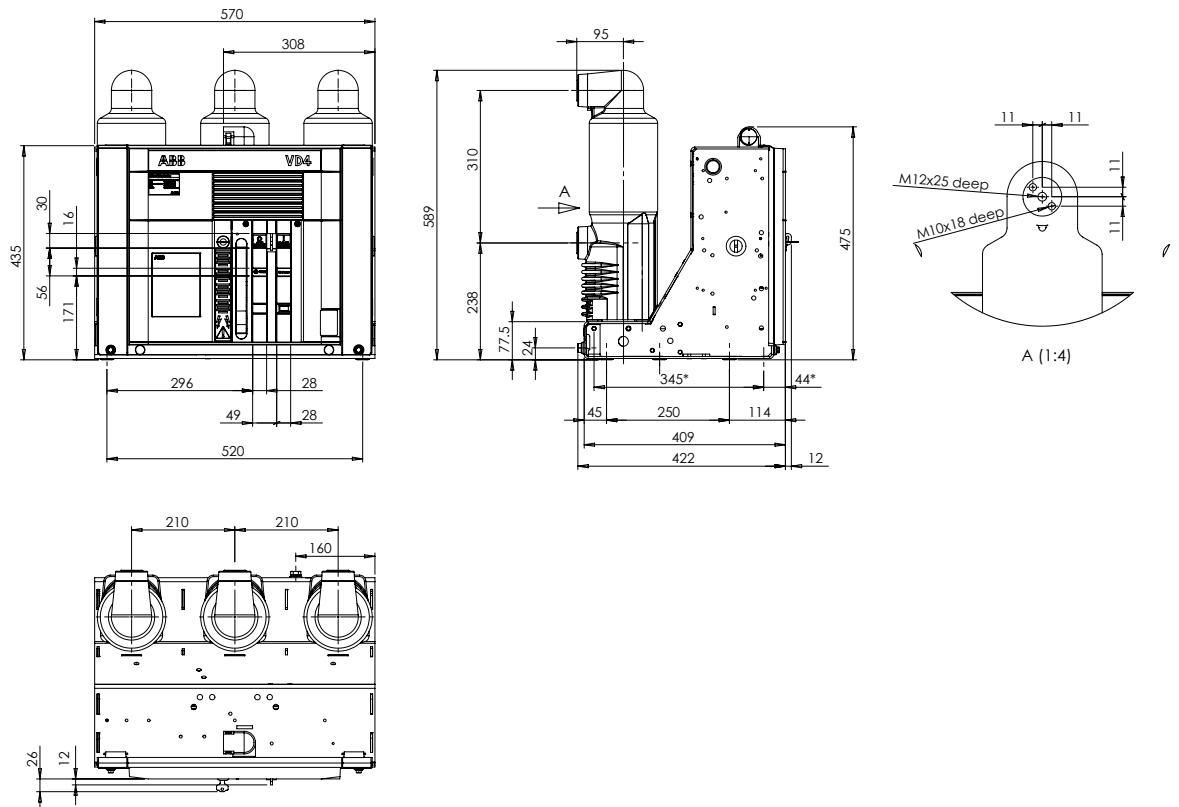

(*) Fixing interchangeability with previous series (345 x 650).

Fixed circuit-breakers

VD4	
TN	1VCD003285
Ur	12 kV
	17.5 kV
Ir	1250 A
	1600 A
Isc	40 kA

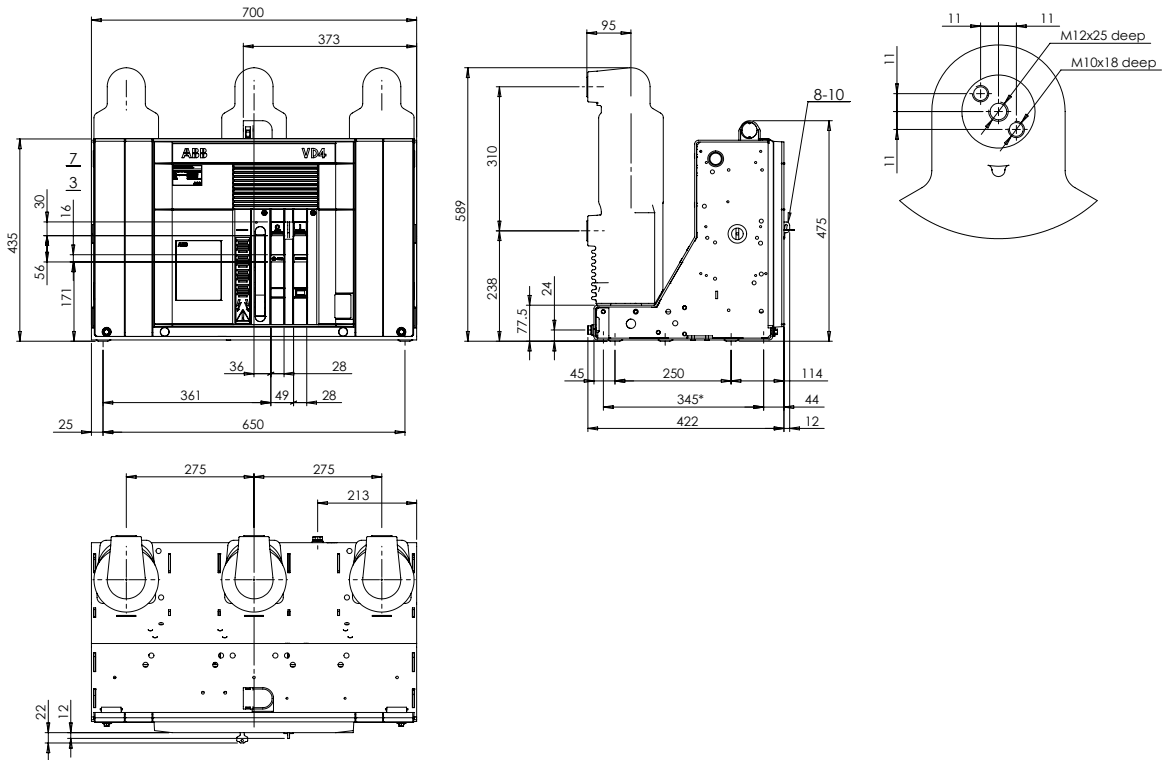

(*) Fixing interchangeability with previous series (345 x 650).

Fixed circuit-breakers

VD4	
TN	1VCD000051
Ur	12 kV
	17.5 kV
Ir	630 A
	1250 A
Isc	16 kA
	20 kA
	31.5 kA

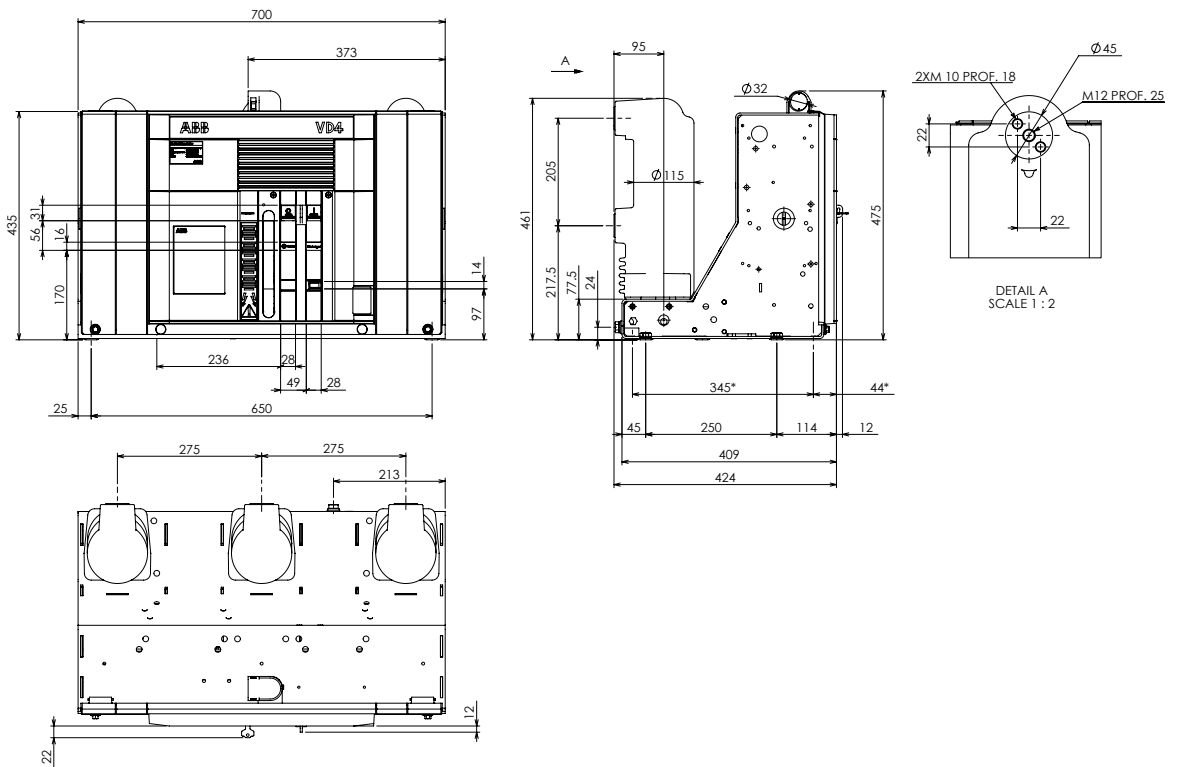

(*) Fixing interchangeability with previous series (345 x 650).

Fixed circuit-breakers

VD4	
TN	7408
Ur	12 kV
	17.5 kV
Ir	1600 A
	2000 A
	2500 A
Isc	20 kA
	25 kA
	31.5 kA

VD4	
TN	7408
Ur	12 kV
	17.5 kV
Ir	2000 A
	2500 A
Isc	40 kA

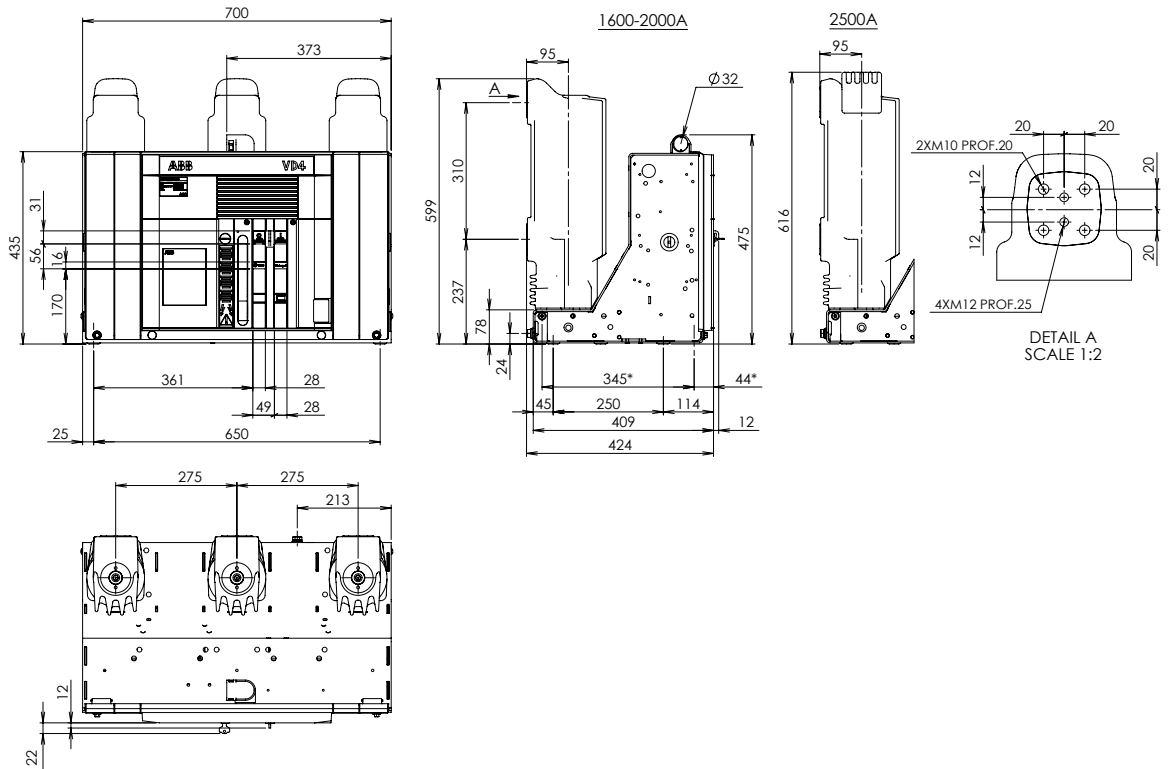

(*) Fixing interchangeability with previous series (345 x 650).

Fixed circuit-breakers

VD4	
TN	7407
Ur	12 kV
Ir	2500 A
	20 kA
Isc	25 kA
	31.5 kA
	40 kA

VD4	
TN	7407
Ur	12-17.5 kV
Ir	1600 A
	2000 A
	20 kA
Isc	25 kA
	31.5 kA
	40 kA

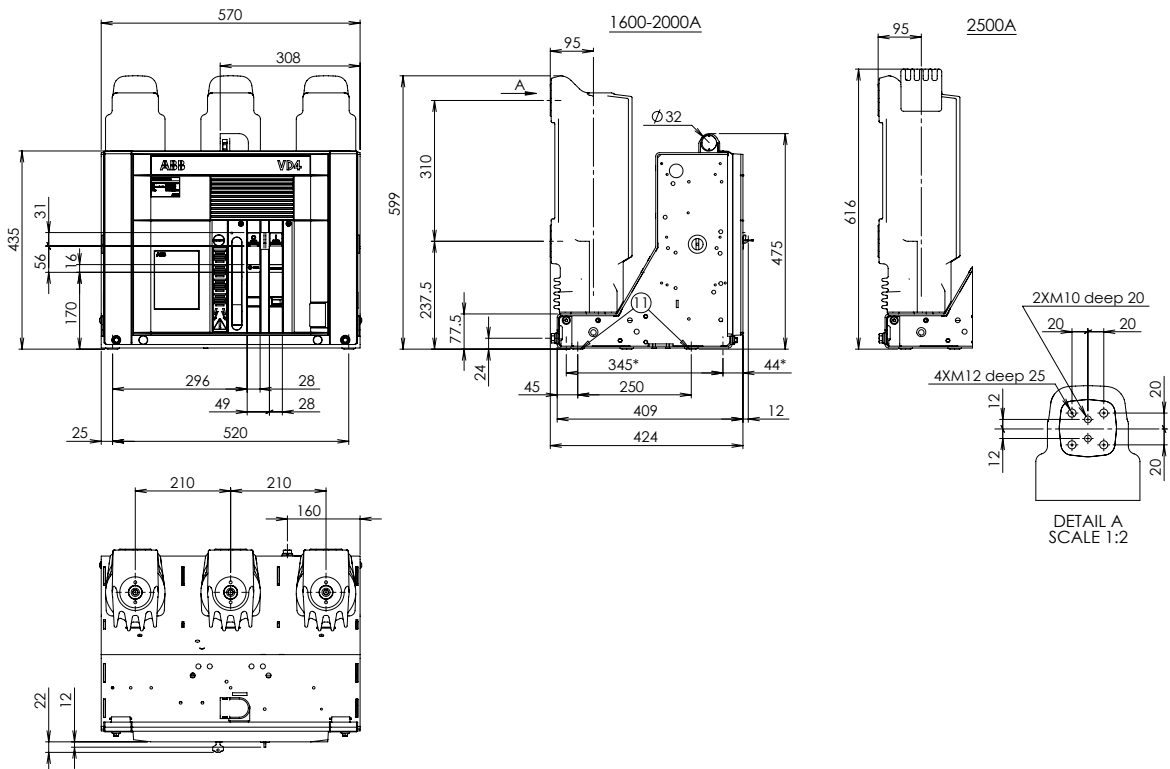

(*) Fixing interchangeability with previous series (345 x 650).

Fixed circuit-breakers

VD4	
TN	1VCD000149
Ur	05-12- 15-17 kV
Ir	3150 A
	4000 A (**)
	20 kA
	25 kA
Isc	31.5 kA
	40 kA
	50 kA

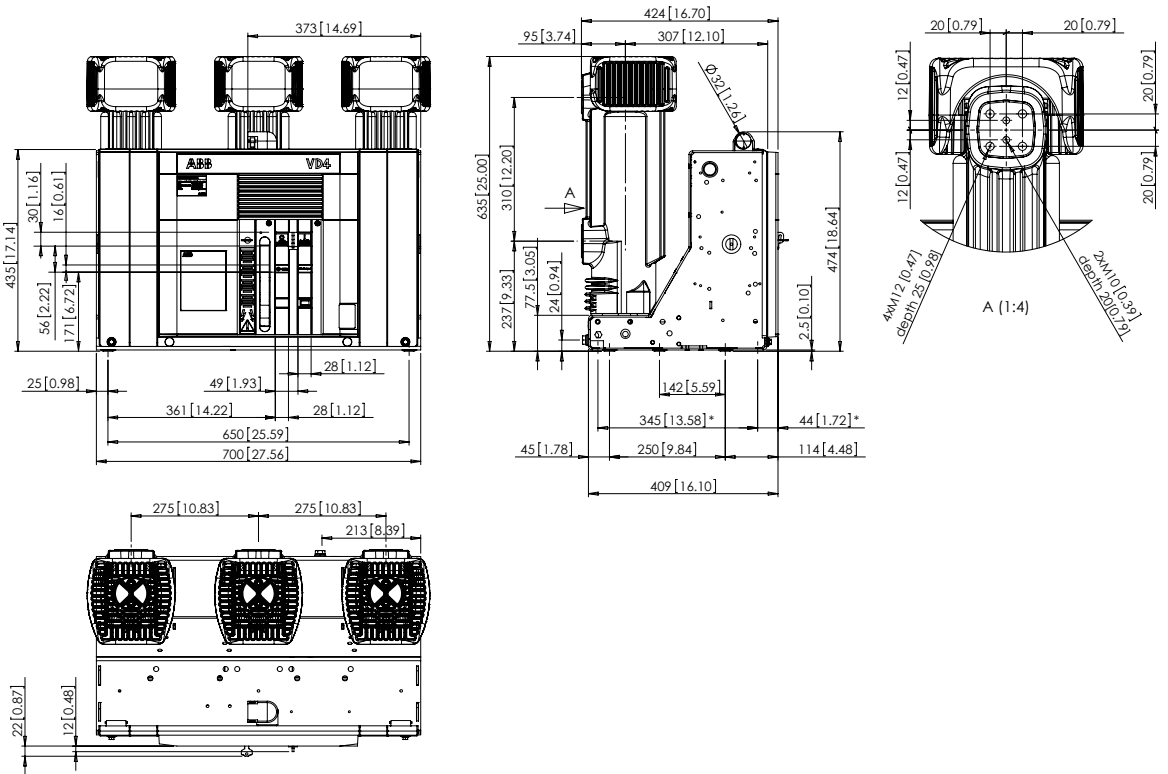

(*) Fixing interchangeability with previous series (345 x 650).

(**) With forced ventilation.

Fixed circuit-breakers

VD4	
TN	1VCD003440
Ur	12 kV 17.5 kV
	1250 A
Ir	1600 A
	2000 A
Isc	50 kA

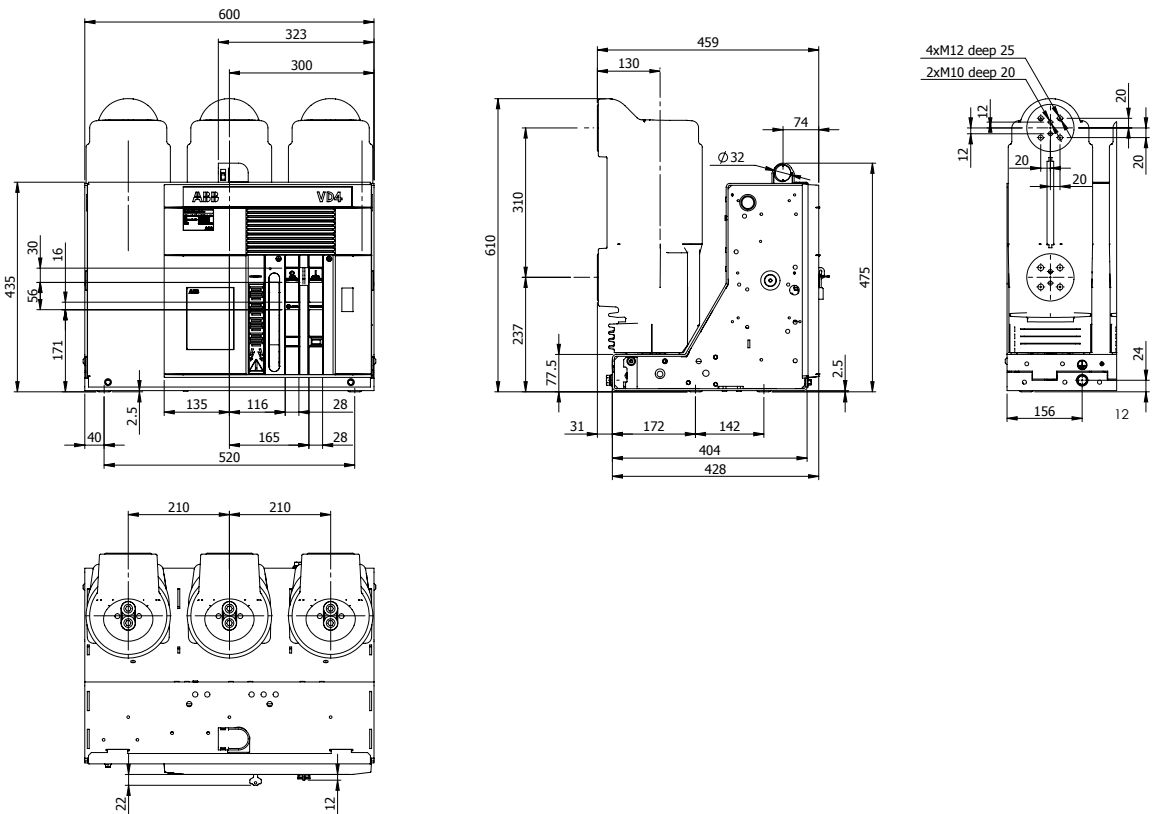

Fixed circuit-breakers

VD4	
TN	7409
Ur	24 kV
Ir	630 A
	1250 A
Isc	16 kA
	20 kA
	25 kA

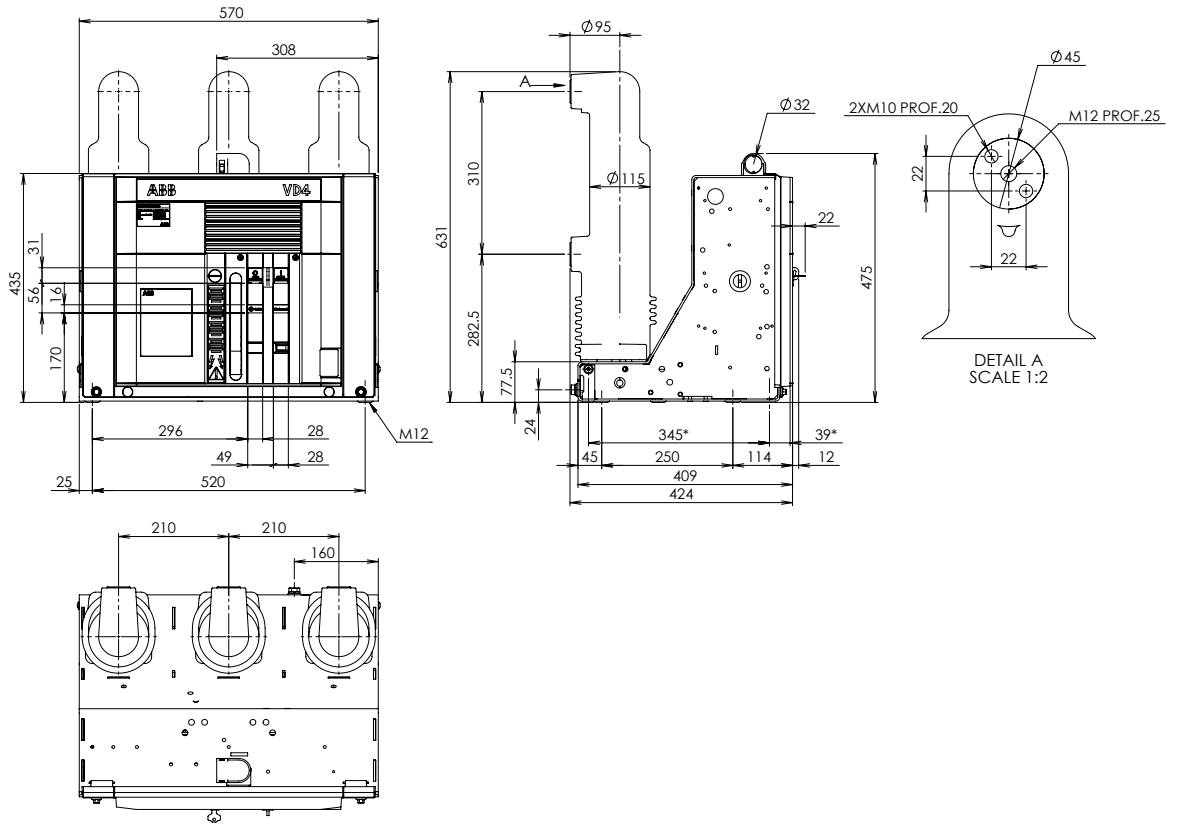

(*) Fixing interchangeability with previous series (345 x 520).

Fixed circuit-breakers

VD4	
TN	7410
Ur	24 kV
Ir	630 A
	1250 A
Isc	16 kA
	20 kA
	25 kA

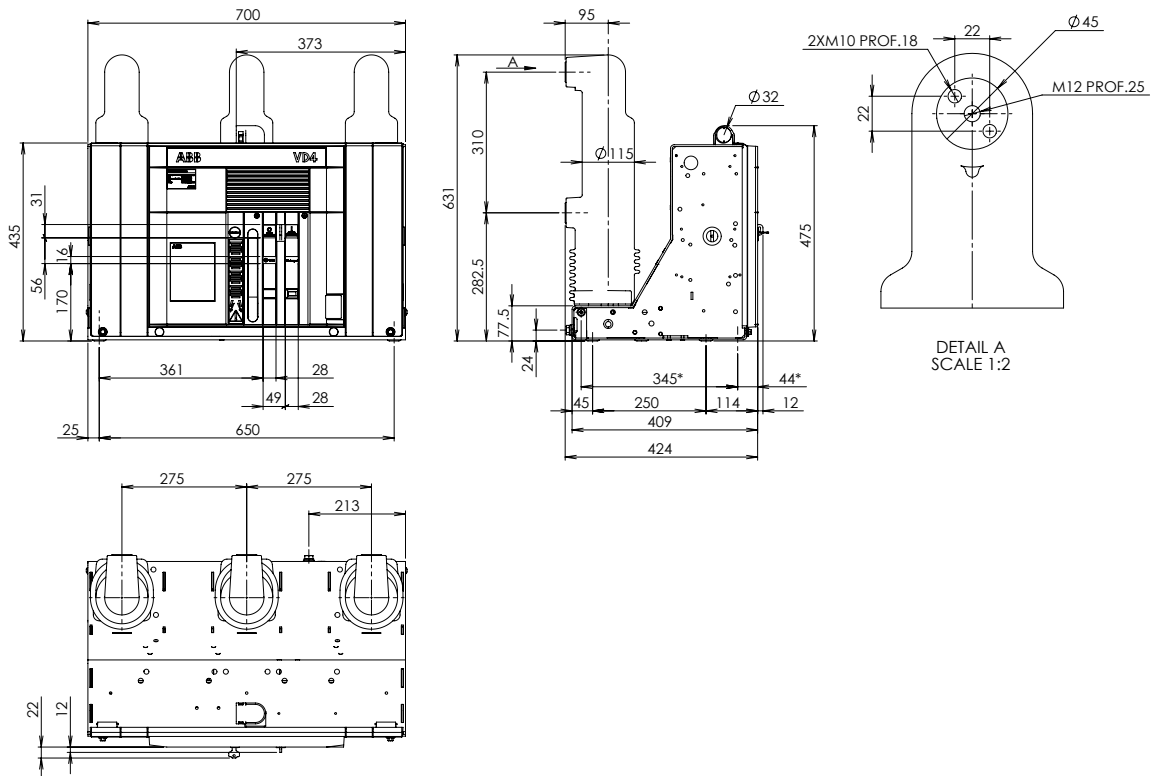

(*) Fixing interchangeability with previous series (345 x 650).

Fixed circuit-breakers

VD4	
TN	7411
Ur	24 kV
	1600 A
Ir	2000 A
	2500 A
	16 kA
Isc	20 kA
	25 kA
	31,5 kA

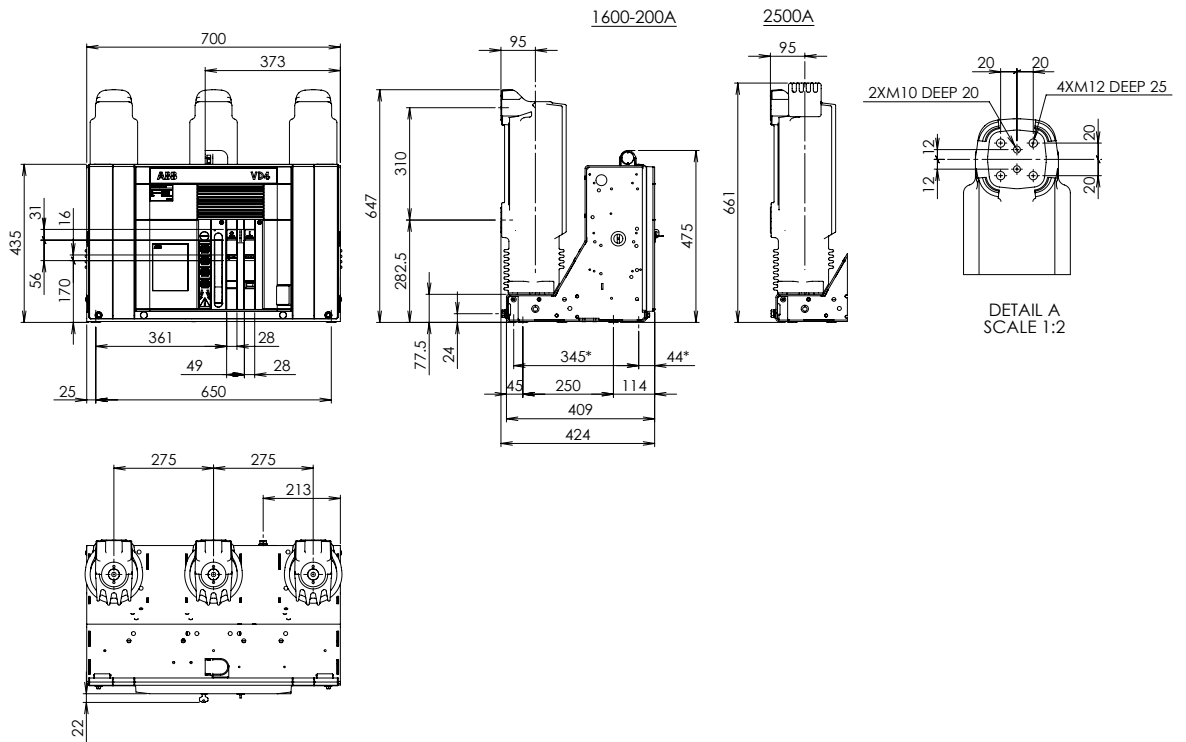

(*) Fixing interchangeability with previous series (345 x 650).

Fixed circuit-breakers

VD4	
TN	1VCD000172
Ur	24 kV
Ir	1250 A
Isc	31.5 kA

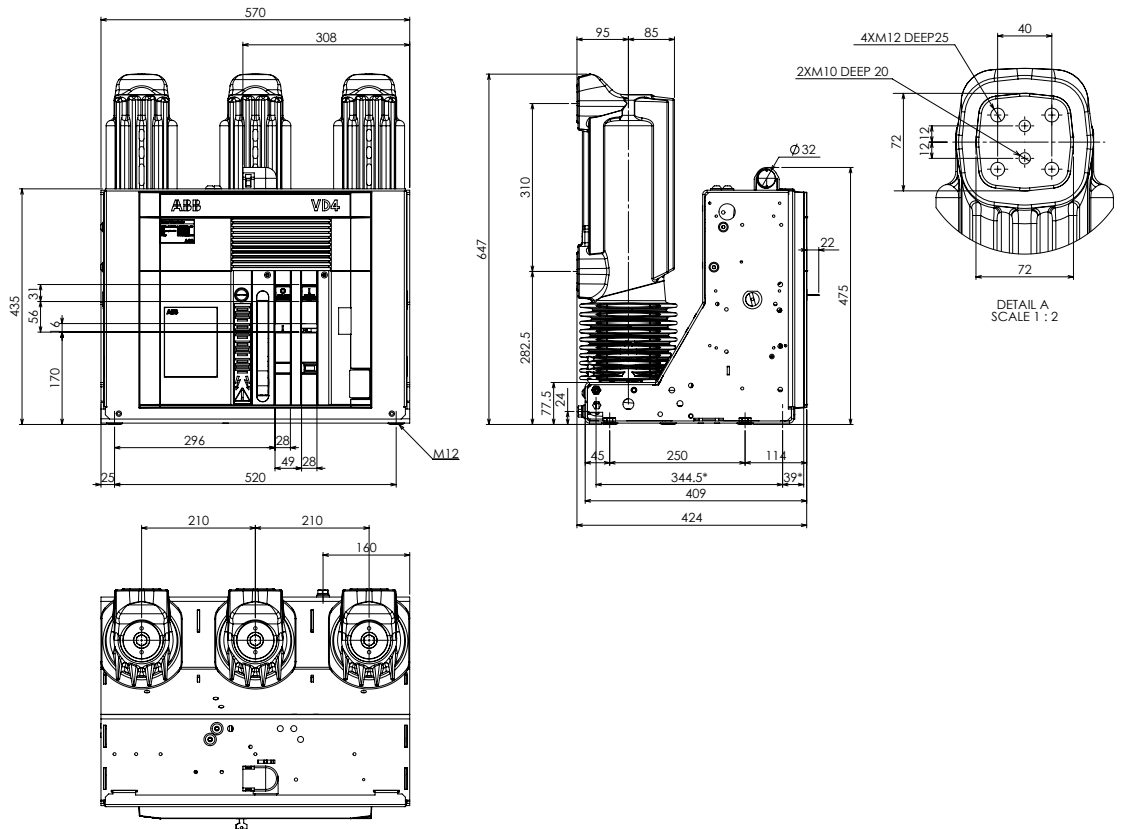

Fixed circuit-breakers

VD4		
TN	1VYN300901-LT	
Ur	36	kV
	1250	A
Ir	1600	A
	2000	A
Isc	31.5	kA

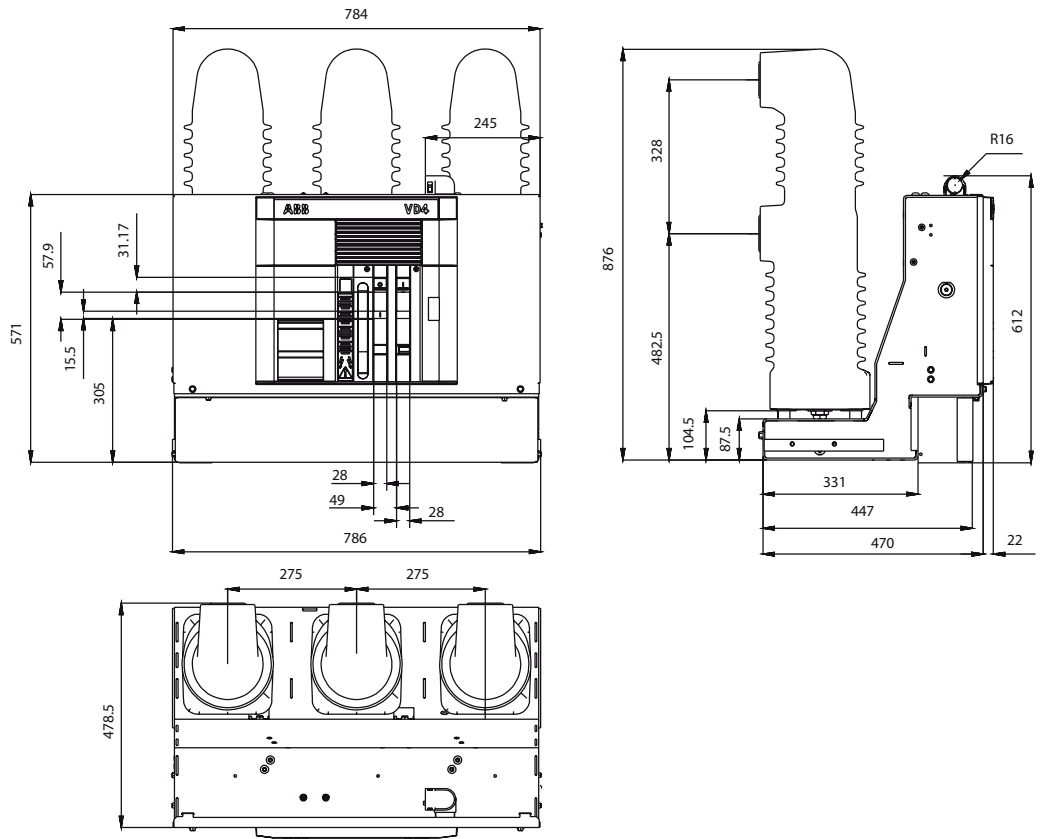

Withdrawable circuit-breakers for UniGear ZS1 switchgear and PowerCube modules

VD4/P	
TN	7412
Ur	12 kV
	17.5 kV
Ir	630 A
	1250 A
Isc	16 kA
	20 kA
	25 kA
	31.5 kA

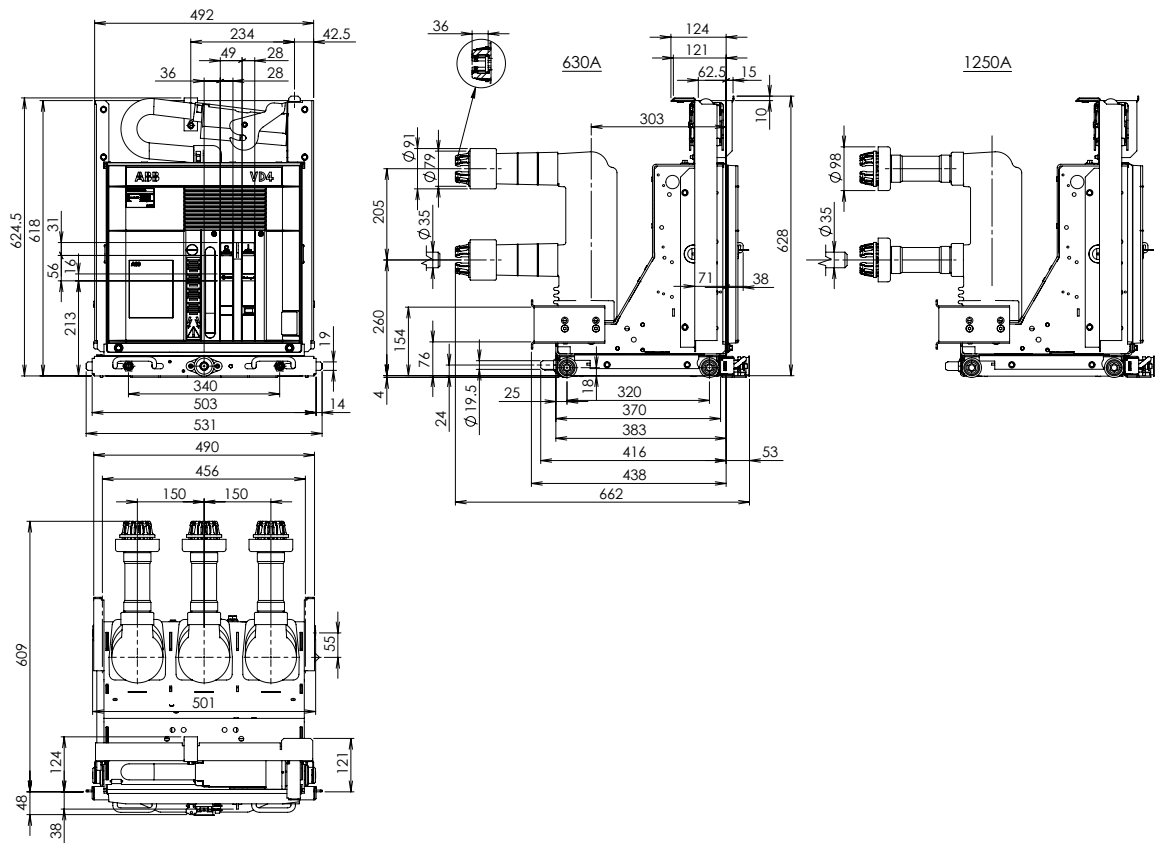

Withdrawable circuit-breakers for PowerCube modules

VD4/W ⁽¹⁾	
TN	7420
Ur	12 kV
	17.5 kV
Ir	630 A
	1250 A
Isc	16 kA
	25 kA
	31.5 kA

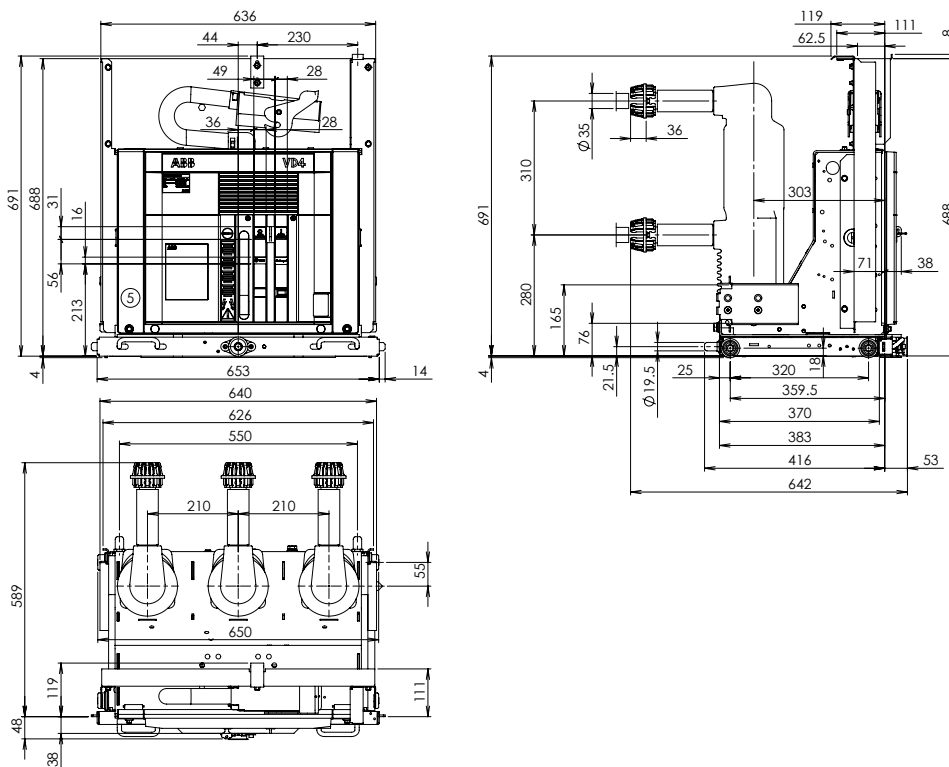

(1) Only for PowerCube modules.

Withdrawable circuit-breakers for UniGear ZS1 switchgear and PowerCube modules

VD4/P	
TN	1VCD003284
Ur	12 kV
	17.5 kV
Ir	1250 A
	1600 A
Isc	40 kA

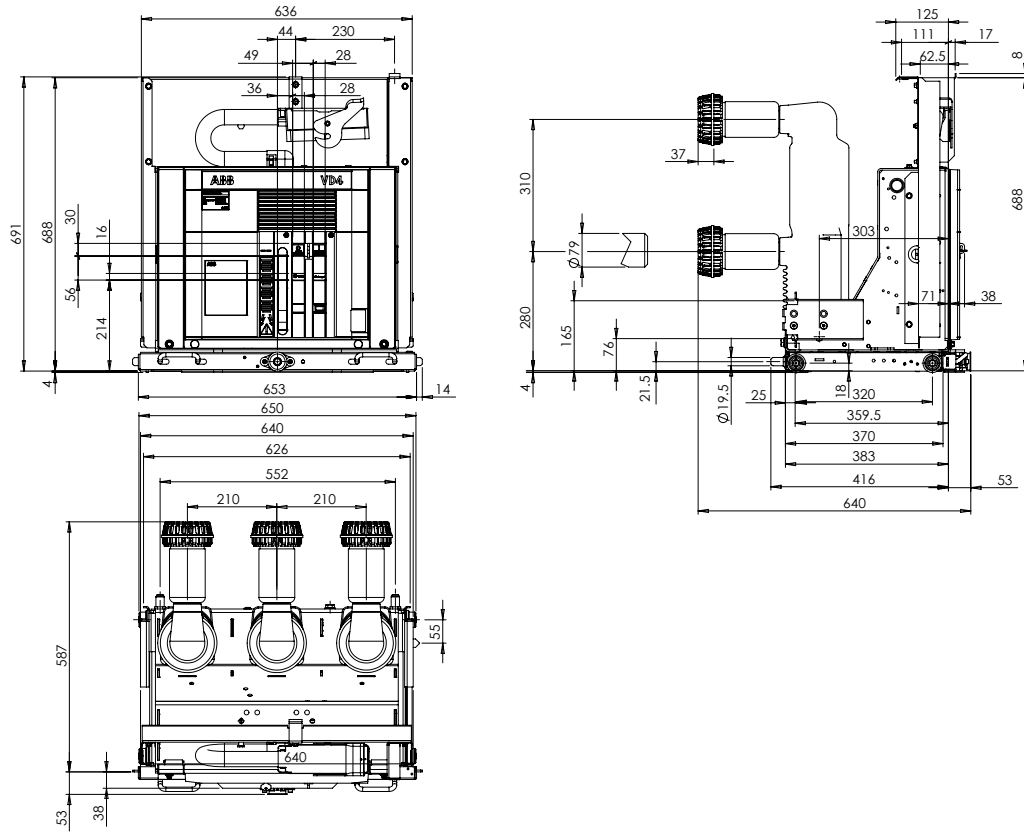

Withdrawable circuit-breakers for UniGear ZS1 switchgear and PowerCube modules

VD4/P	
TN	1VCD003286
Ur	12 kV
	17.5 kV
Ir	1250 A
	1600 A
Isc	40 kA

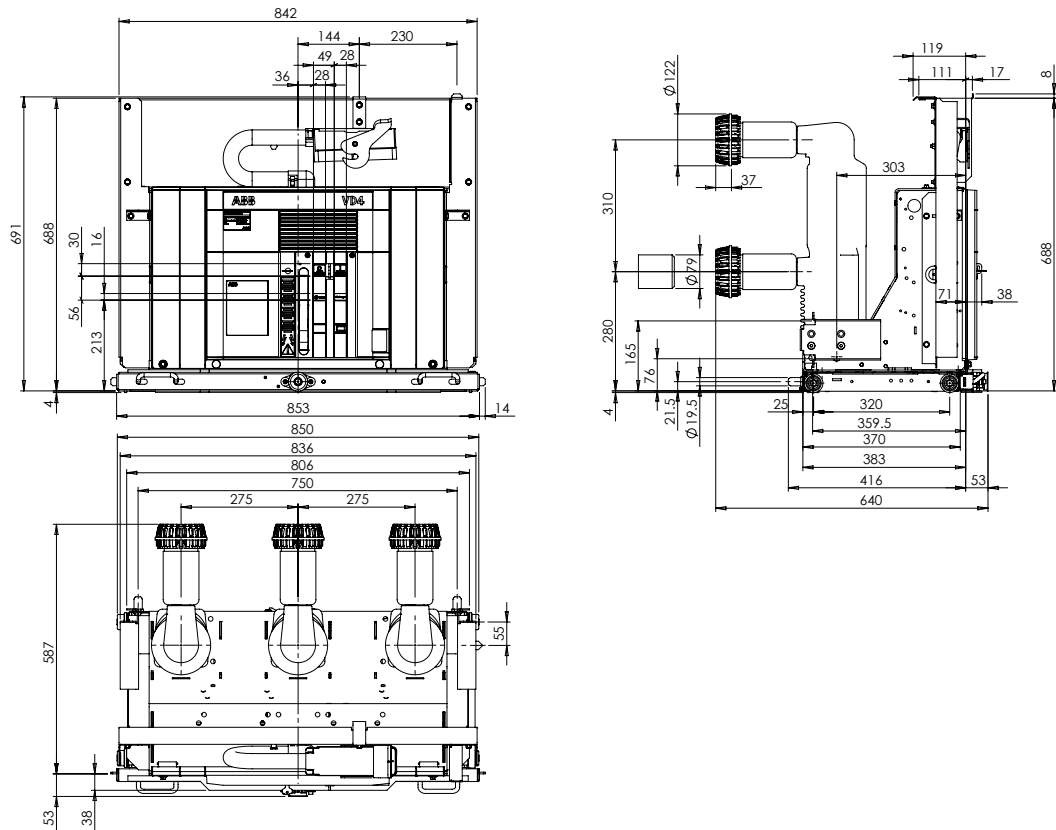

Withdrawable circuit-breakers for UniGear ZS1 switchgear and PowerCube modules

VD4/P	
TN	7415
Ur	12 kV
	17.5 kV
Ir	1600 A
	2000 A
Isc	20 kA
	25 kA
	31.5 kA

VD4/P	
TN	7415
Ur	12 kV
	17.5 kV
Ir	2000 A
Isc	40 kA

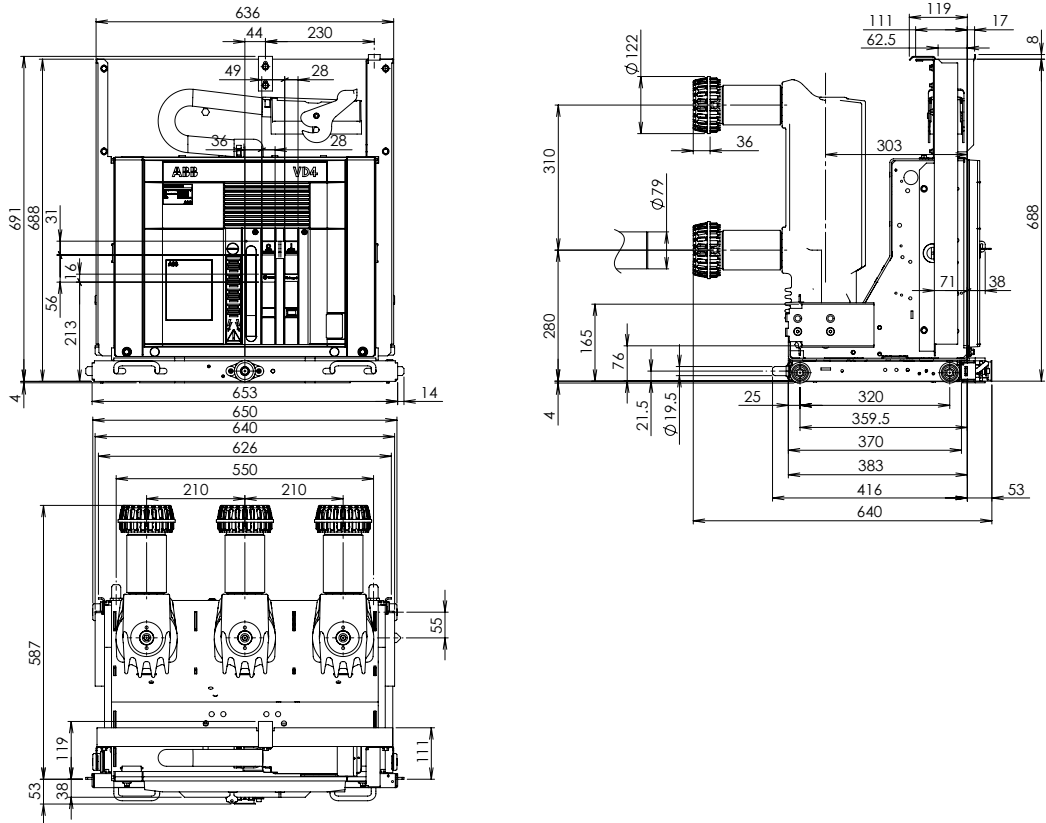

Withdrawable circuit-breakers for UniGear ZS1 switchgear and PowerCube modules

VD4/P	
TN	7416
Ur	12 kV
	17.5 kV
Ir	1600 A
	2000 A
Isc	20 kA
	25 kA
	31.5 kA

VD4/P	
TN	7416
Ur	12 kV
	17.5 kV
Ir	2000 A
Isc	40 kA

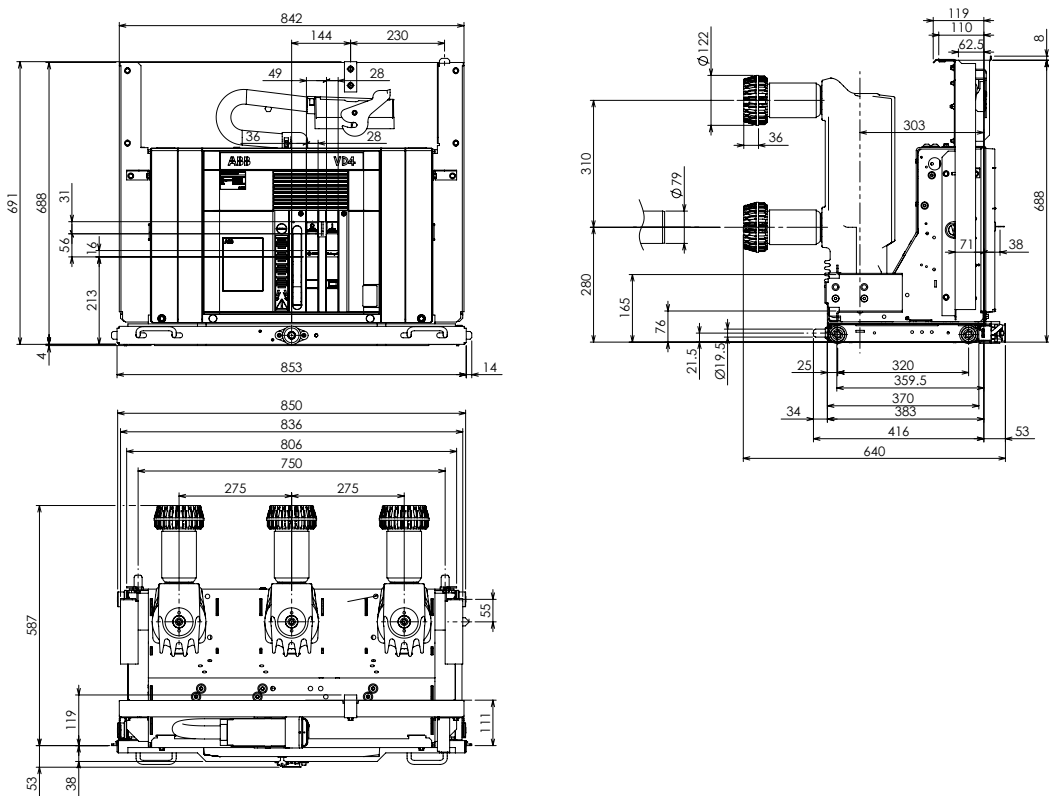

Withdrawable circuit-breakers for UniGear ZS1 switchgear and PowerCube modules

VD4/P	
TN	7417
Ur	12 kV
	17.5 kV
Ir	2500 A
	20 kA
Isc	25 kA
	31.5 kA
	40 kA

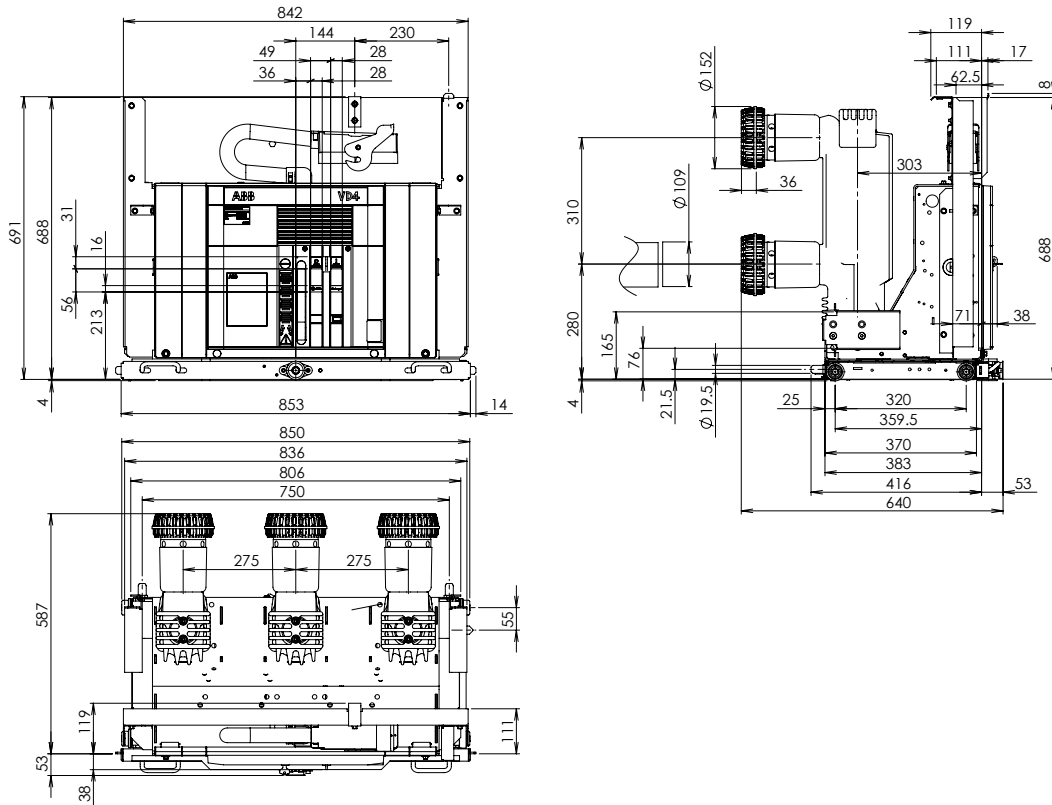

Withdrawable circuit-breakers for UniGear ZS1 switchgear and PowerCube modules

VD4/P	
TN	1VCD003444
Ur	12 kV
	17.5 kV
Ir	1250 A
	1600 A
Isc	2000 A
	50 kA

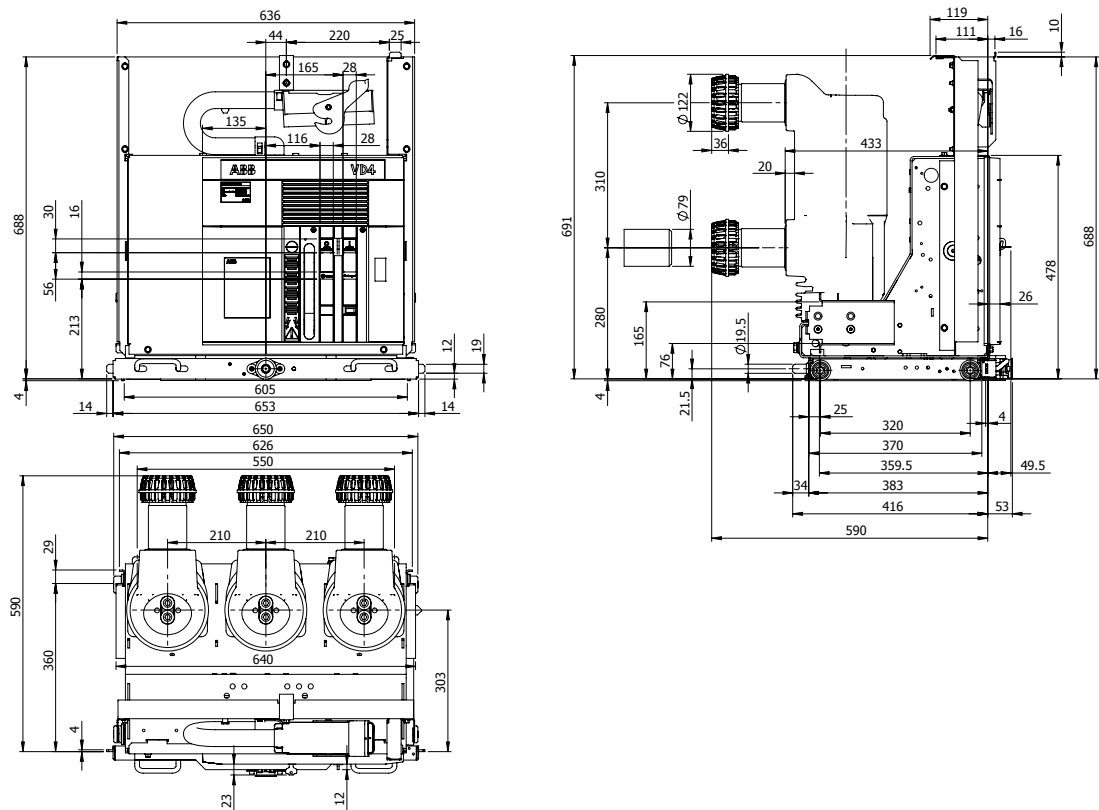

Withdrawable circuit-breakers for UniGear ZS1 switchgear and PowerCube modules

VD4/P	
TN	1VCD003445
Ur	12 kV
	17.5 kV
Ir	1600 A
	2000 A
Isc	50 kA

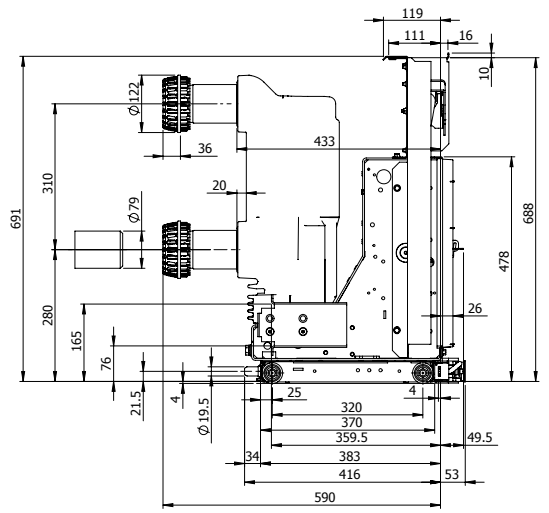
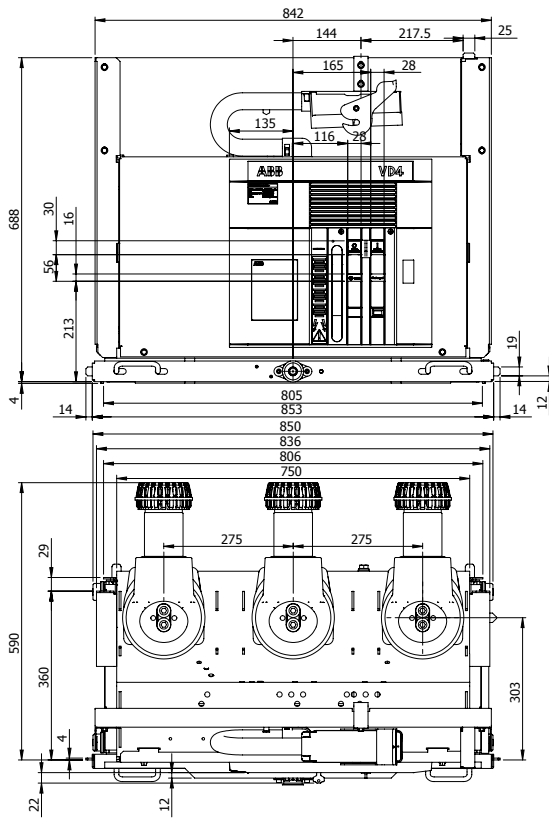

Withdrawable circuit-breakers for UniGear ZS1 switchgear and PowerCube modules

VD4/P	
TN	1VCD003446
Ur	12 kV
	17.5 kV
Ir	2500 A
	50 kA

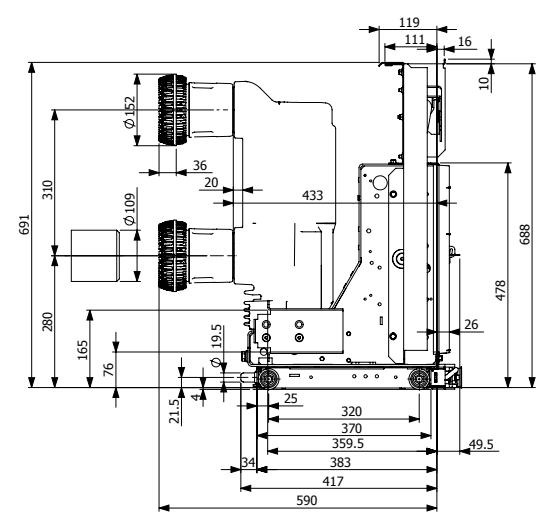
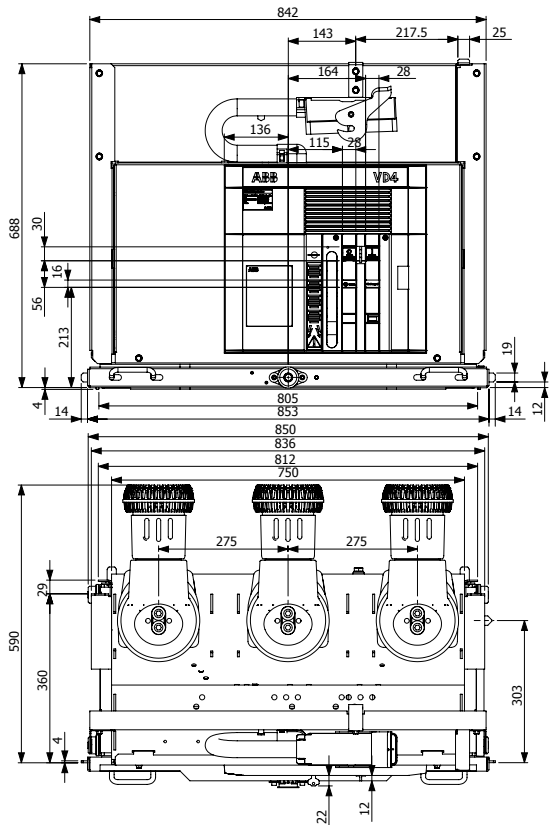

Withdrawable circuit-breakers for PowerCube modules

VD4/W	
TN	1VCD003596
Ur	12 kV
	17.5 kV
Ir	3150 A (*)
Isc	50 kA

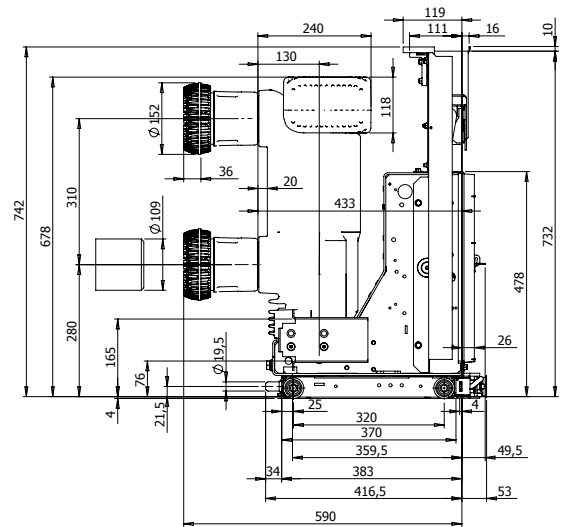
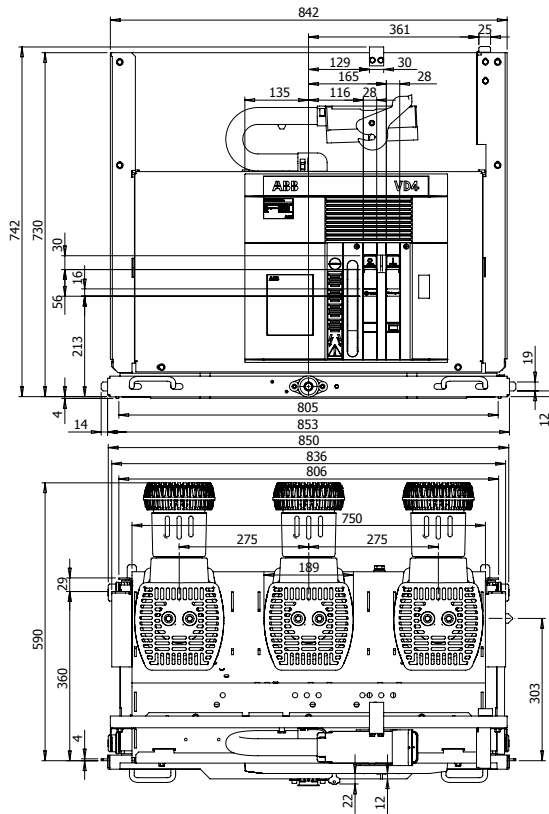

(*) 4000 A with forced ventilation.

Withdrawable circuit-breakers for UniGear ZS1 switchgear

VD4/P	
TN	1VCD003447
Ur	12 kV
	17.5 kV
Ir	3150 A (*)
Isc	50 kA

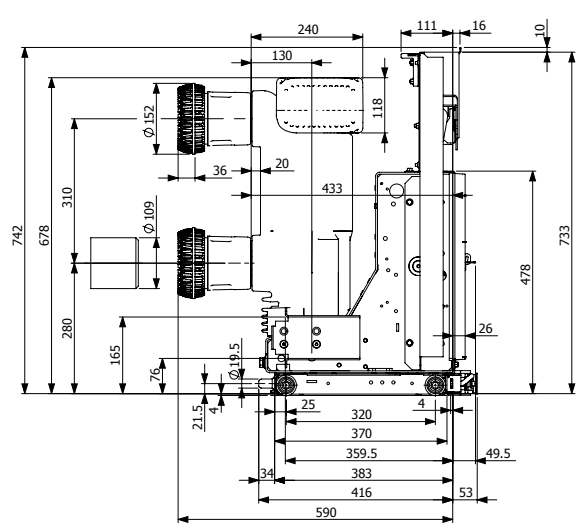
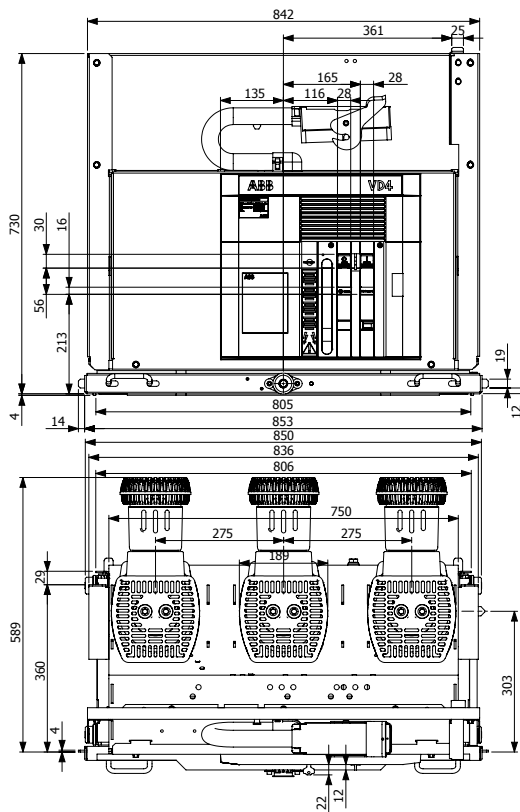

(*) 4000 A with forced ventilation.

Withdrawable circuit-breakers for UniGear ZS1 switchgear

VD4/P	
TN	1VCD000153
Ur	12 kV
	17.5 kV
Ir	3150 A (*)
	20 kA
Isc	25 kA
	31.5 kA
	40 kA

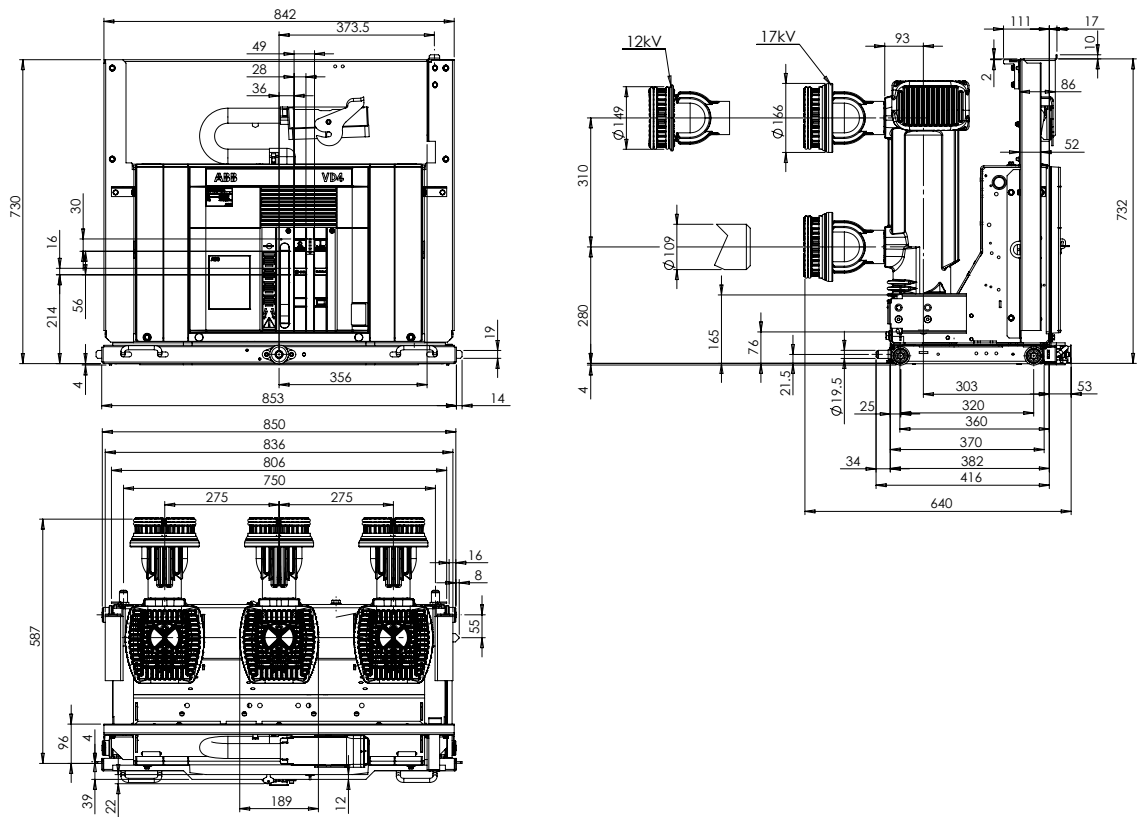

(*) 4000 A with forced ventilation.

Withdrawable circuit-breakers for UniGear ZS1 switchgear and PowerCube modules

VD4/P	
TN	7413
Ur	24 kV
Ir	630 A
	1250 A
Isc	16 kA
	20 kA
	25 kA

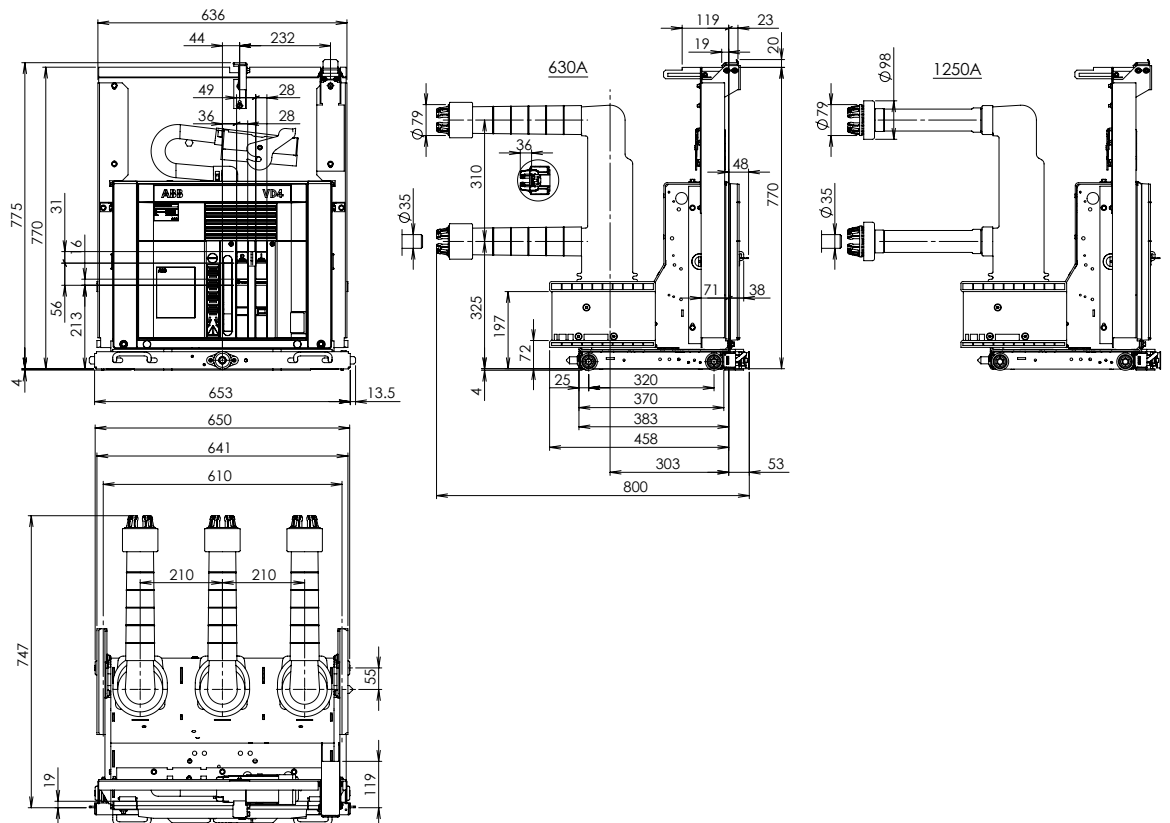

Withdrawable circuit-breakers for UniGear ZS1 switchgear

VD4/P	
TN	7414
Ur	24 kV
Ir	630 A
	1250 A
Isc	16 kA
	20 kA
	25 kA

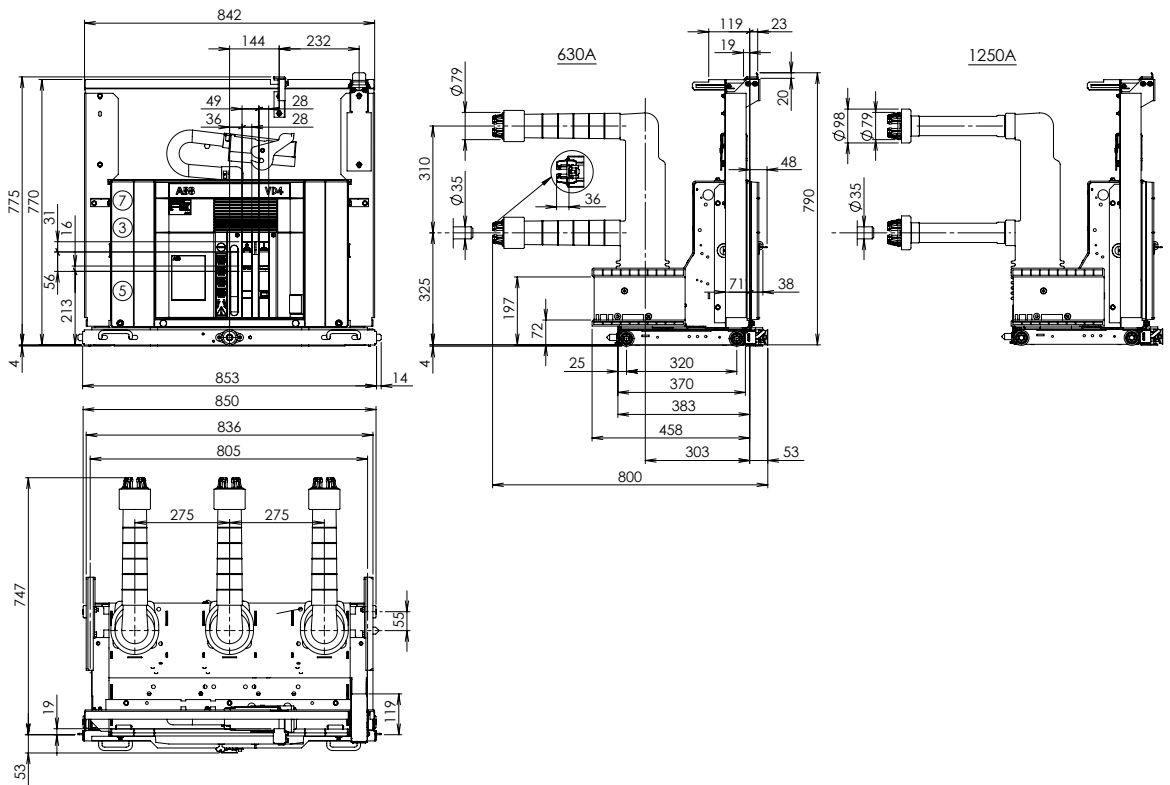

Withdrawable circuit-breakers for UniGear ZS1 switchgear

VD4/P	
TN	7418
Ur	24 kV
Ir	1600 A
	2000 A
	2500 A ⁽¹⁾
Isc	16 kA ⁽²⁾
	20 kA
	25 kA
	31.5 kA

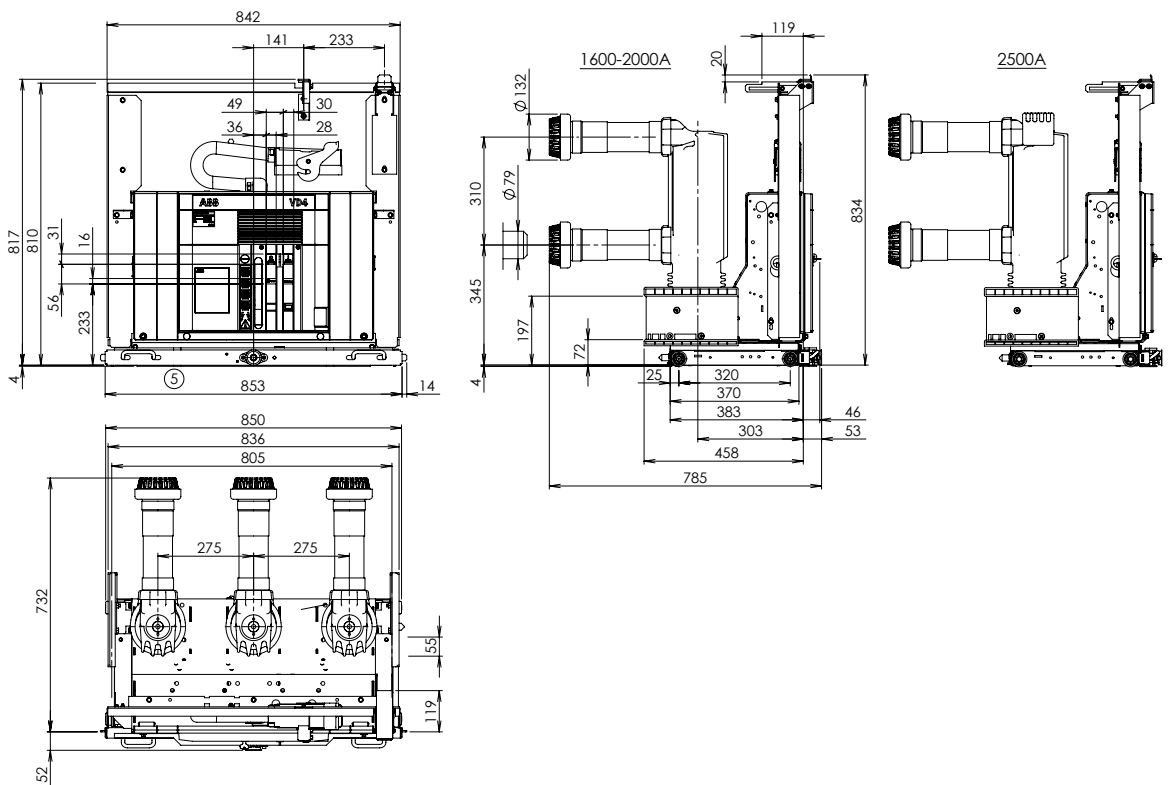

(1) The rated uninterrupted current of 2300 A is guaranteed with natural ventilation. The rated uninterrupted current of 2500 A is guaranteed with forced ventilation.
 (2) Only for UniGear ZS1 switchgear.

Withdrawable circuit-breakers for PowerCube modules

VD4/W	
TN	1VCD000152
Ur	12 kV
	17.5 kV
Ir	3150 A (*)
	20 kA
Isc	25 kA
	31.5 kA
	40 kA

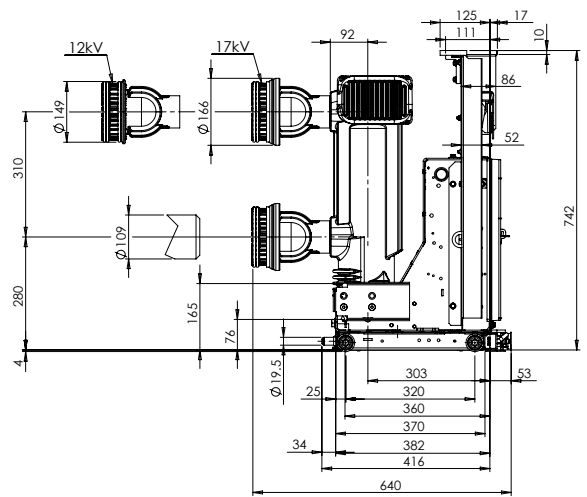
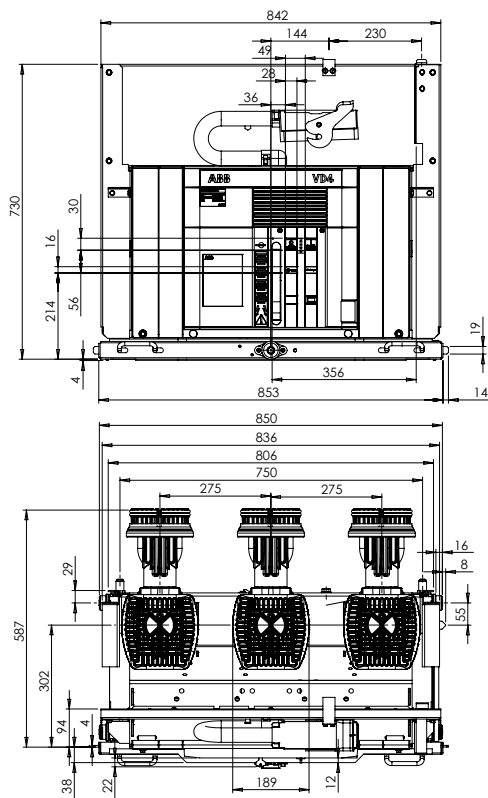

(*) 4000 A with forced ventilation.

Withdrawable circuit-breakers for ZS8.4 switchgear

VD4/Z8	
TN	1VCD000092
Ur	12 kV
Ir	630 A
Isc	20 kA
	25 kA

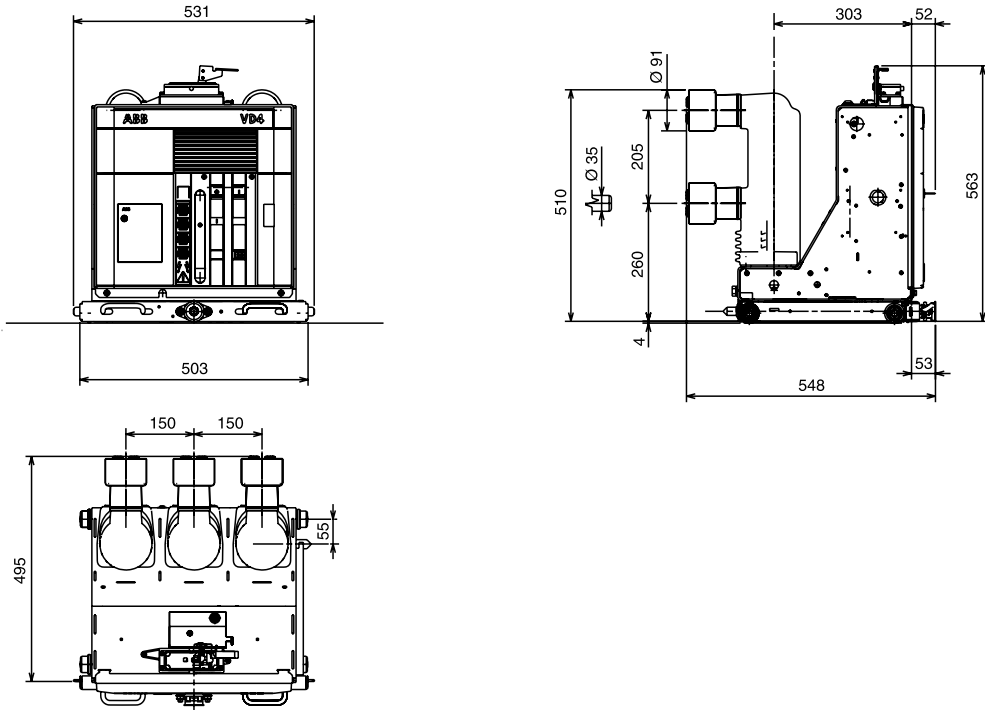

Withdrawable circuit-breakers for ZS8.4 switchgear

VD4/ZT8	
TN	1VCD000093
Ur	12 kV
Ir	630 A
Isc	20 kA
	25 kA

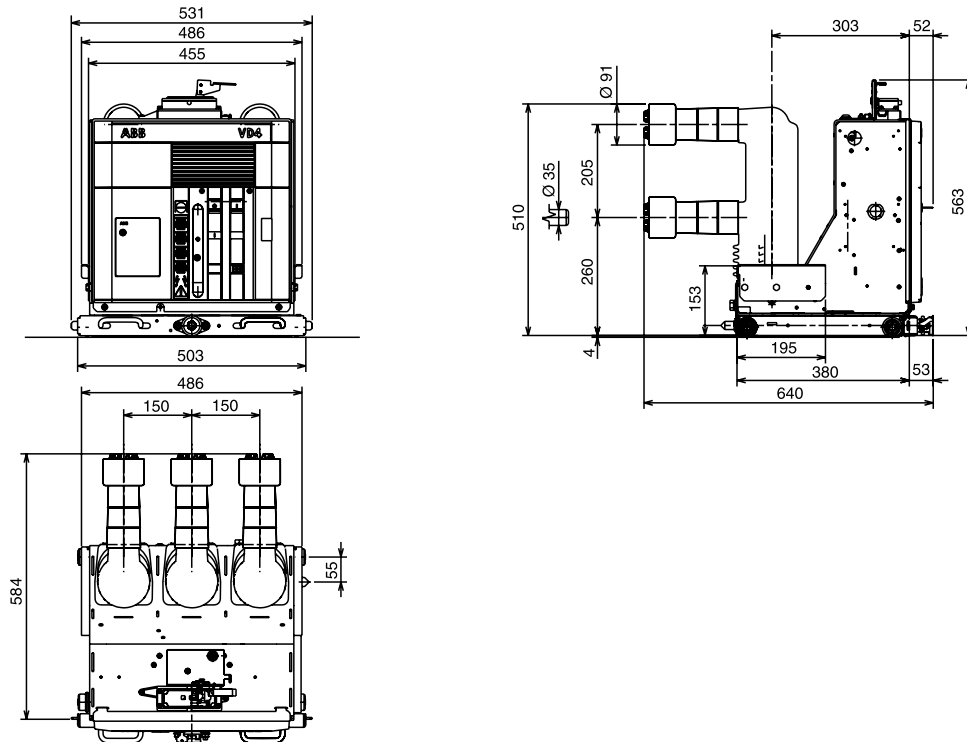

Withdrawable circuit-breakers for ZS8.4 switchgear

VD4/ZS8	
TN	1VCD000091
Ur	12 kV
Ir	630 A
Isc	20 kA
	25 kA

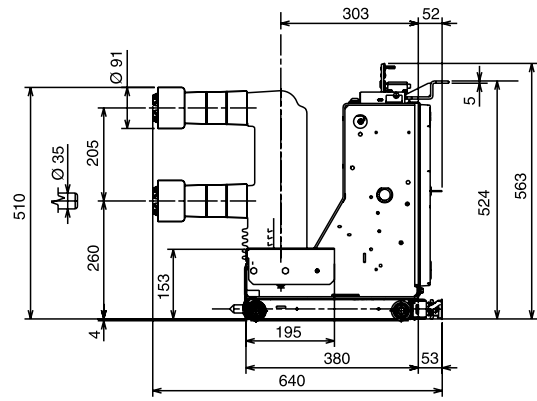
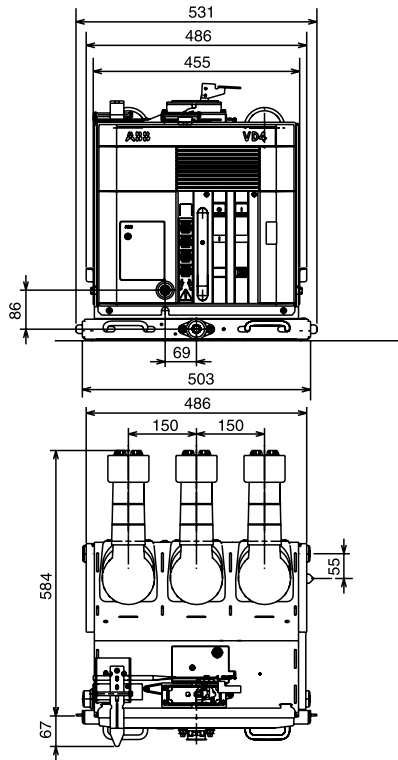

Withdrawable circuit-breakers for ZS8.4 switchgear

VD4/ZS8	
TN	1VCD000133
Ur	12 kV
Ir	1250 A
Isc	20 kA
	25 kA

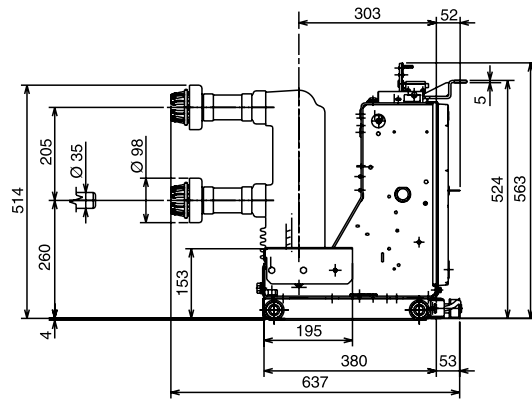
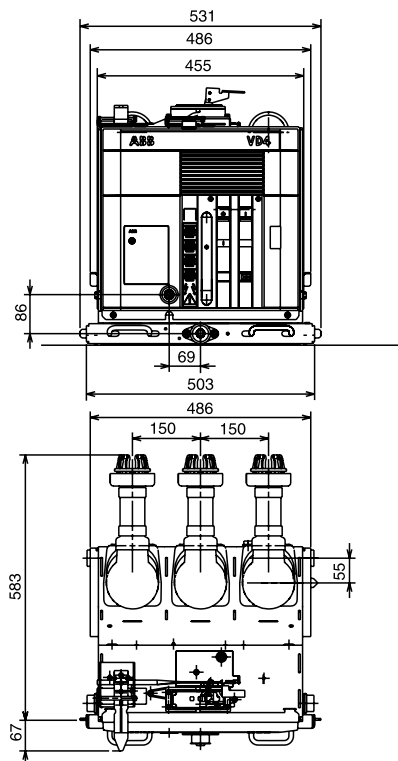

Withdrawable circuit-breakers for ZS8.4 switchgear

VD4/Z8	
TN	1VCD000137
Ur	12 kV
	17.5 kV
Ir	630 A
	1250 A
Isc	20 kA
	25 kA

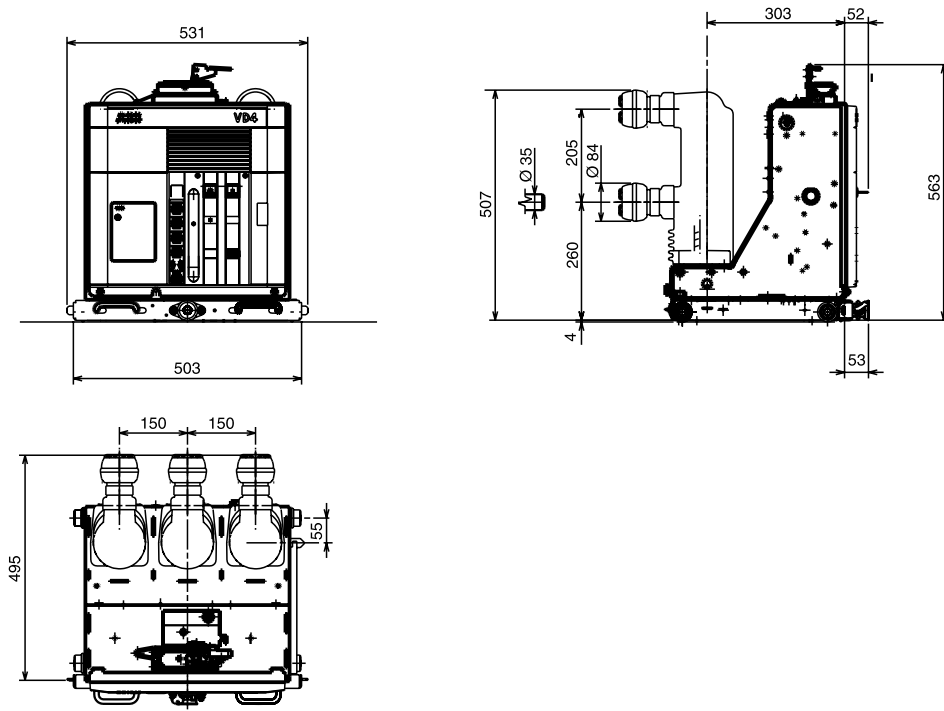

Withdrawable circuit-breakers for ZS8.4 switchgear

VD4/ZT8	
TN	1VCD000134
Ur	12 kV
	17.5 kV
Ir	630 A
	1250 A
Isc	20 kA
	25 kA

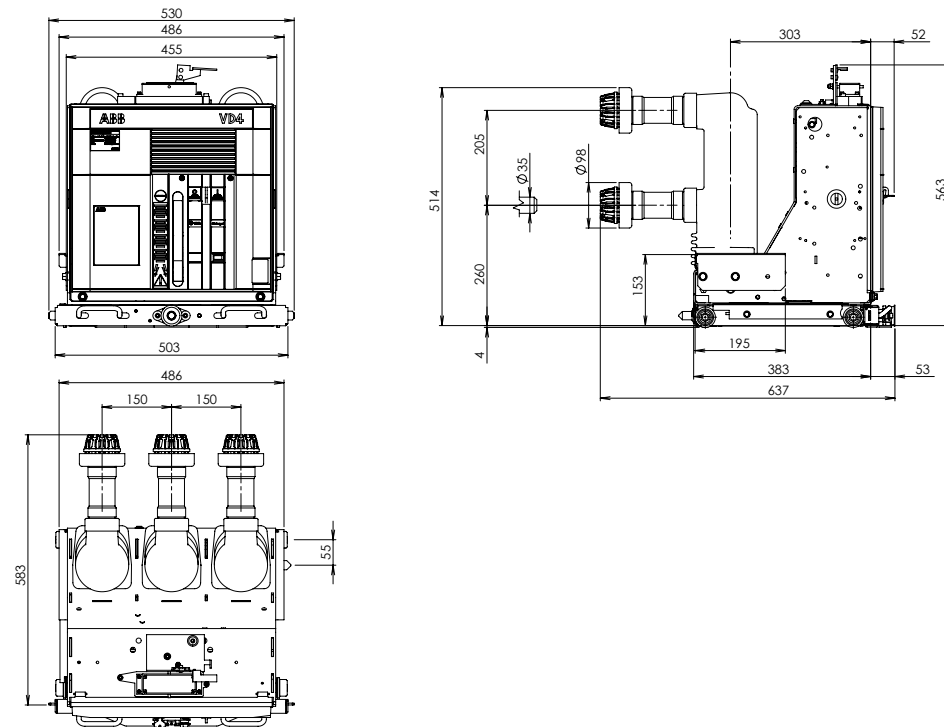

Withdrawable circuit-breakers for ZS8.4 switchgear

VD4/Z8	
TN	1VCD000138
Ur	24 kV
Ir	1250 A
Isc	16 kA
	20 kA
	25 kA

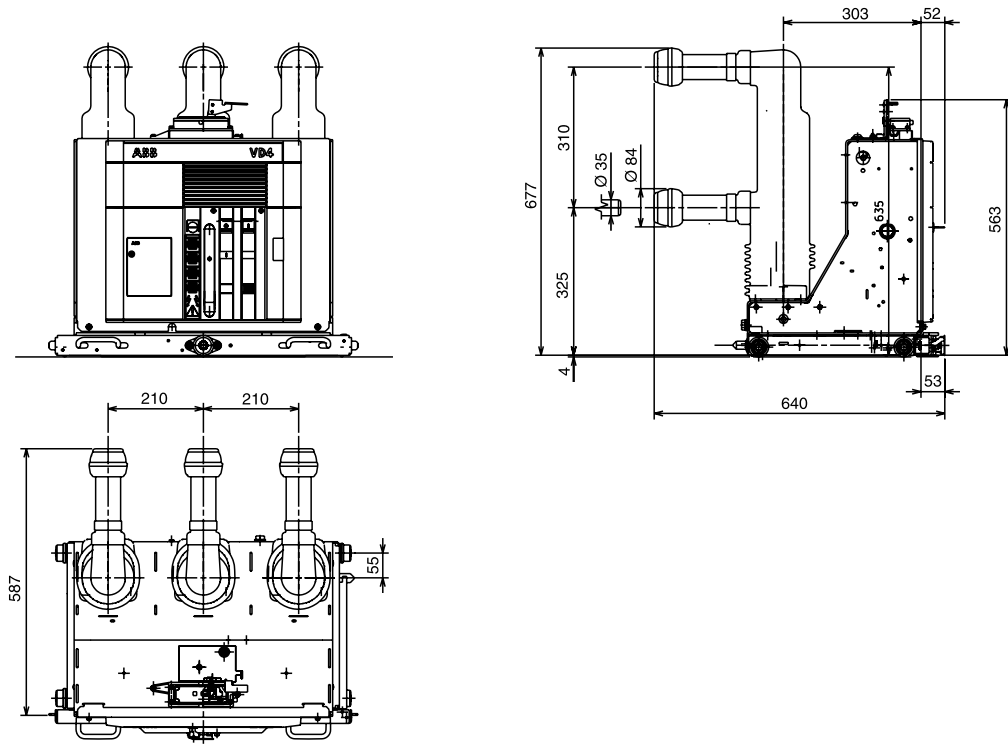

Withdrawable circuit-breakers for ZS8.4 switchgear

VD4/ZT8	
TN	1VCD000090
Ur	24 kV
Ir	630 A
Isc	16 kA
	20 kA
	25 kA

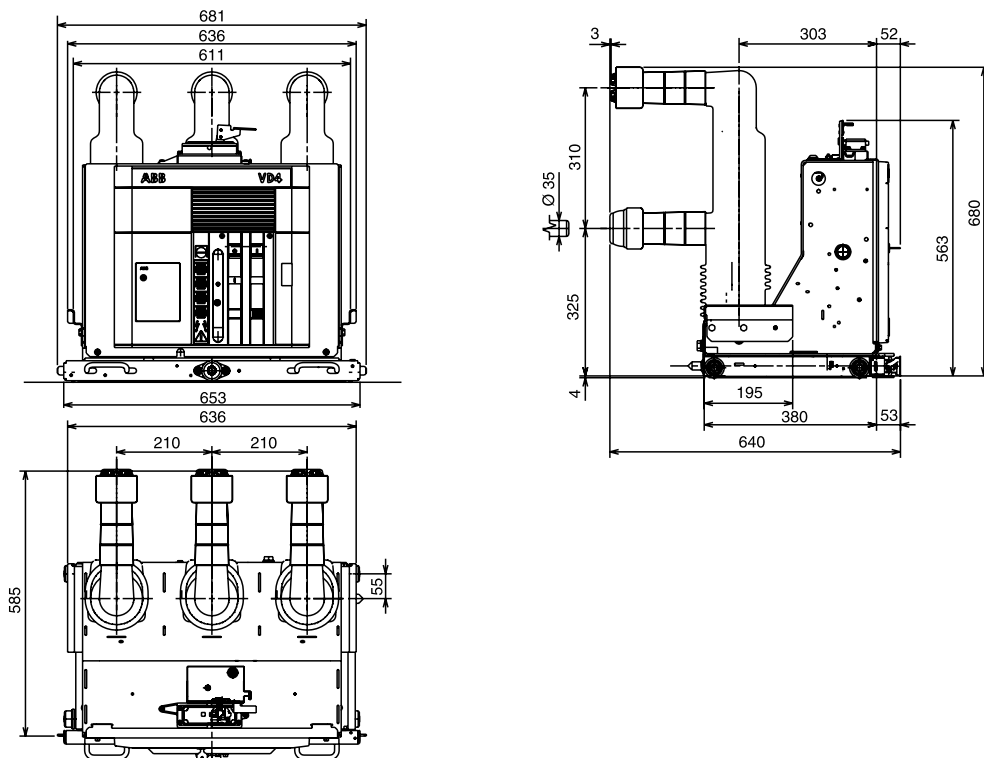

Withdrawable circuit-breakers for ZS8.4 switchgear

VD4/ZT8	
TN	1VCD000136
Ur	24 kV
Ir	1250 A
	16 kA
Isc	20 kA
	25 kA

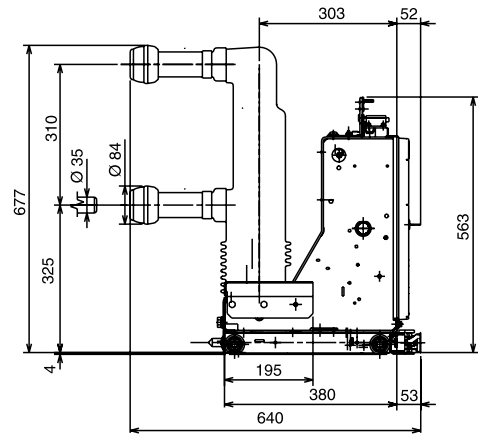
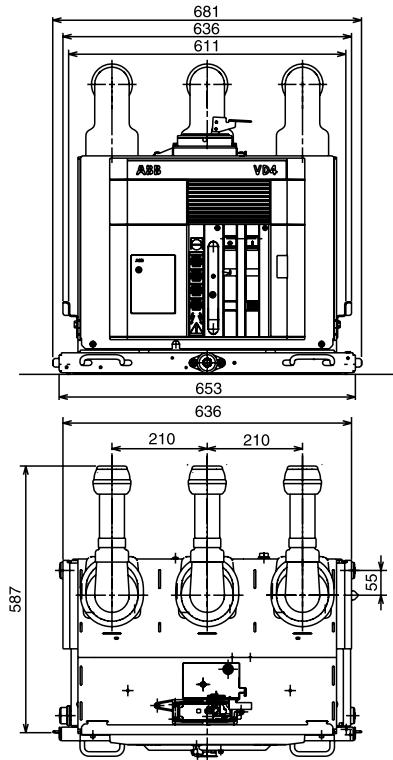

Withdrawable circuit-breakers for ZS8.4 switchgear

VD4/ZS8	
TN	1VCD000135
Ur	24 kV
Ir	1250 A
	16 kA
Isc	20 kA
	25 kA

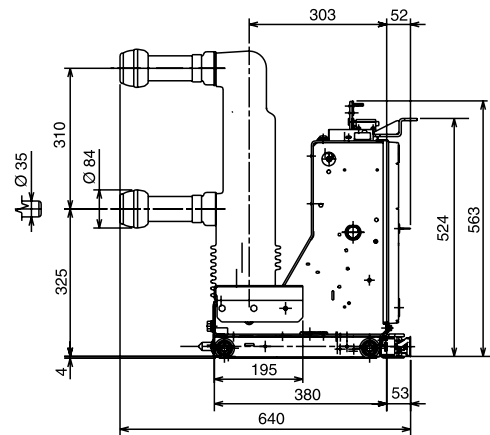
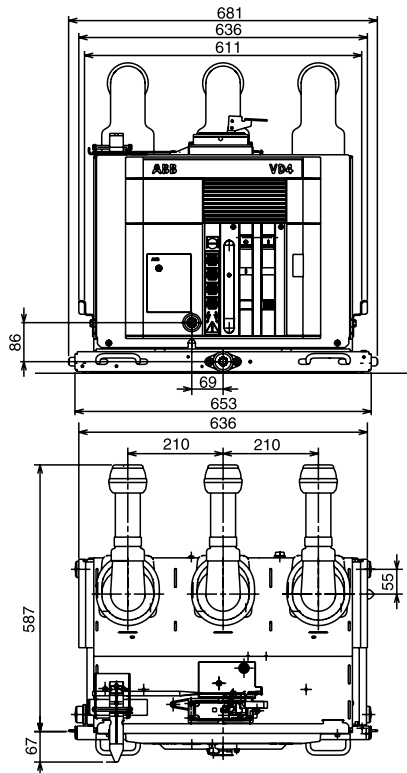

Withdrawable circuit-breakers for UniSwitch / UniMix switchgears

VD4/US	
TN	1VCD000047
Ur	24 kV
Ir	630 A
	1250 A
Isc	16 kA
	20 kA
	25 kA

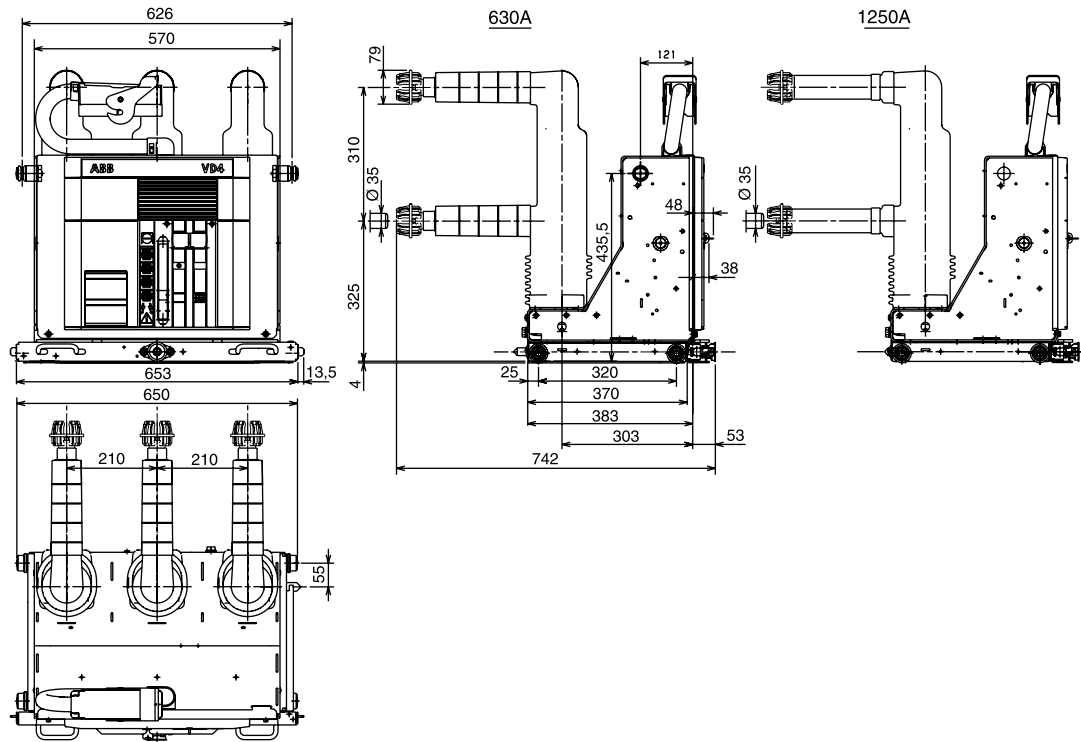

Withdrawable circuit-breakers for UniSec switchgears

VD4/SEC	
TN	1VCD000190
Ur	24 kV
Ir	630 A
	1250 A
Isc	16 kA
	20 kA
	25 kA

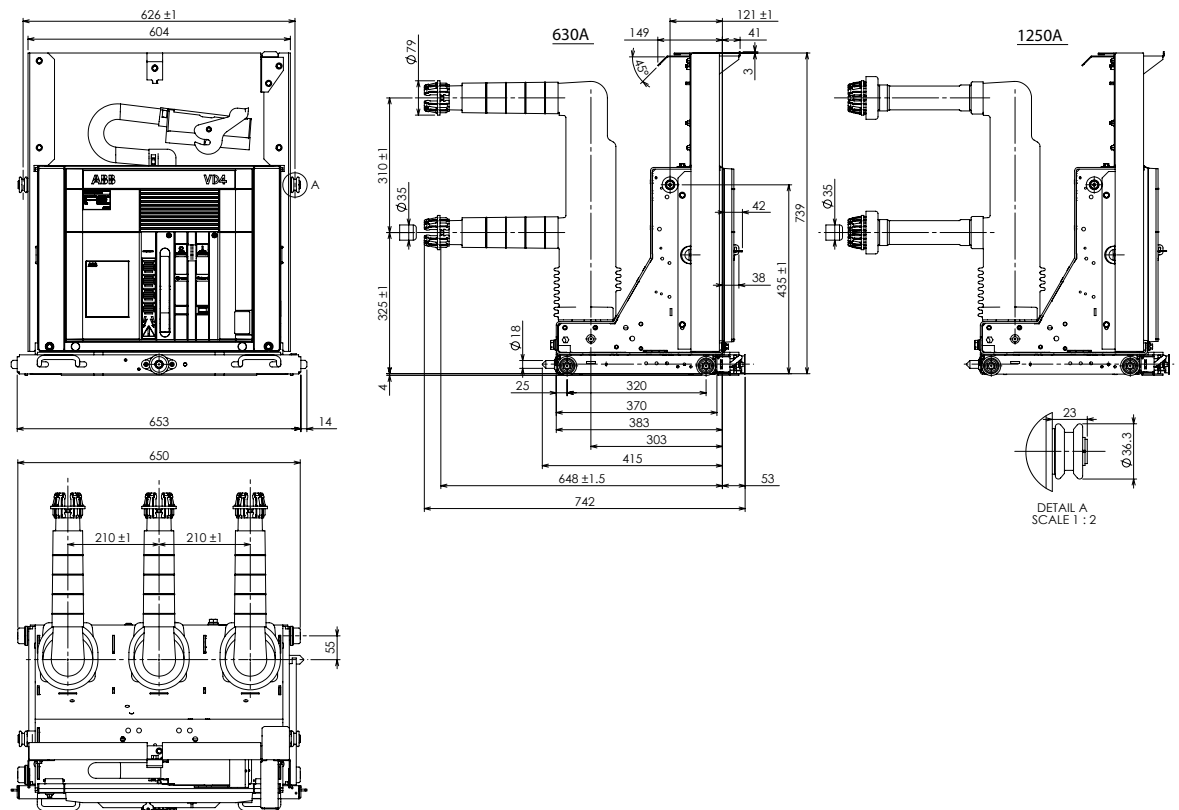

Withdrawable circuit-breakers for UniGear ZS2 switchgear and PowerCube modules (36 kV)

VD4	
TN	1VYN300901-KG
Ur	36 kV
	1250 A
Ir	1600 A
	2000 A
Isc	31.5 kA

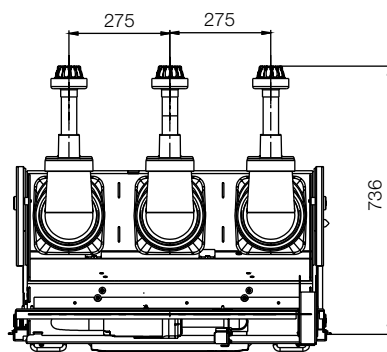
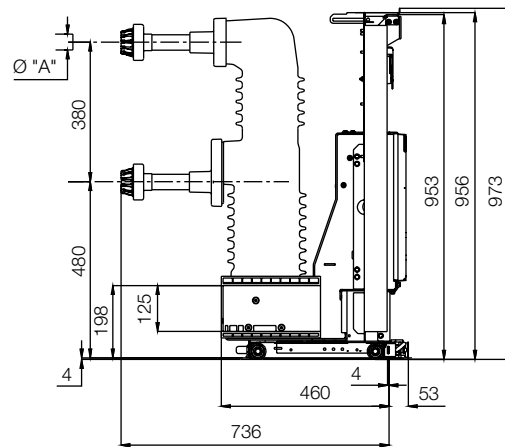
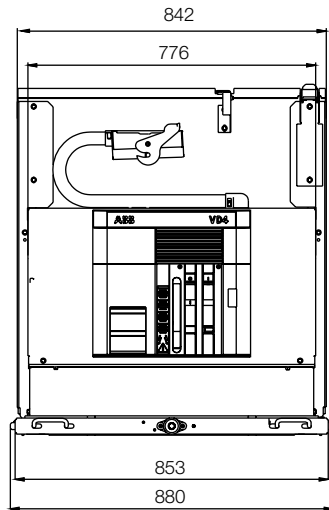

Breaker type	$\varnothing A$ mm
VD4 36.12.32	35
VD4 36.16.32	79
VD4 36.20.32	75

14. Product quality and environmental protection

The apparatus are produced in compliance with the requirements of international standards for the quality management system and environmental management system. In these fields, the excellent level is proved by quality certificates according to ISO 9001 and by the EMS according to ISO 14 001.

End of life of product

The ABB company is committed to complying with the relevant legal and other requirements for environment protection according to the ISO 14 001 standard.

The duty of company is to facilitate subsequent recycling or disposal at the end of product life. During disposal of the product, it is always necessary to act in accordance with local legal requirements in force.

Methods of disposal

Disposal can either be carried out thermally in an incineration plant or by storing on a waste site.

RAW MATERIAL	RECOMMENDED METHOD OF DISPOSAL
Metal material (Fe, Cu, Al, Ag, Zn, W, others)	Separation and recycling
Thermoplasts	Recycling or disposal
Epoxy resin	Separation of metal material and the disposal of rest
Rubber	Disposal
Oil as dielectric (transformer oil)	Draining from equipment and further recycling or disposal
SF6 gas	Discharging from equipment and further recycling or disposal
Packing material – wood	Recycling or disposal
Packing material – foil	Recycling or disposal

For more information please contact:

ABB S.p.A.

Power Products Division

Unità Operativa Sace-MV

Via Friuli, 4

I-24044 Dalmine

Tel.: +39 035 6952 111

Fax: +39 035 6952 874

E-mail: info.mv@it.abb.com

ABB AG

Calor Emag Medium Voltage Products

Oberhausener Strasse 33

Petzower Strasse 8

D-40472 Ratingen

D-14542 Glindow

Phone: +49(0)2102/12-1230,

Fax: +49(0)2102/12-1916

E-mail: powertech@de.abb.com

www.abb.com

The data and illustrations are not binding. We reserve the right to make changes without notice in the course of technical development of the product.

© Copyright 2012 ABB. All rights reserved.