

MEDIUM VOLTAGE PRODUCT

VT Guard Pro / VT Guard Pro-D

Instructions for installation, use and maintenance





Scope of Contents

3	1. Description
3	2. Application and settings
3	VT Guard Pro
4	VT Guard Pro-D
5	3. Installation
5	4. Operating condition
6	5. Technical parameters
6	6. Dimensional drawing
6	7. Maintenance and service
6	8. Warranty
6	9. Disposal

Instructions for installation, use and maintenance for the VT Guard Pro / VT Guard Pro-D

01 Demonstration of VT Guard Pro effectiveness – dumping action

1. Description

VT Guard Pro is an advanced security device which protects MV inductive voltage transformers (VTs) against ferroresonant oscillations. It is designed to be used in open-delta connection of three single-phase VTs. Ferroresonant oscillations may be initiated by transient events (such as switching operations) in power networks. The undamped ferroresonant oscillations are dangerous to the equipment installed due to large overcurrents and overvoltages which may lead to permanent damage of the equipment. VT Guard Pro belongs to a new family of advanced protection devices which protect VTs against ferroresonant phenomena by proper and prompt damping action (Fig. 1.), without creating excessive power consumption (as in case of using ordinary damping resistors) during normal operation of the network.

Two versions of the VT Guard Pro are available:

- a) VT Guard Pro
- b) VT Guard Pro-D

Both versions are identical from functionality point of view (dumping ability), but the VT Guard Pro-D has extended functions which allows self-diagnostic. This diagnostic feature allows the device to check itself (functionality of its circuits) and is able to send information about its state into a superior system.

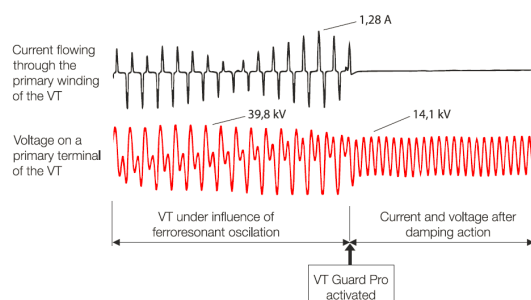

2. Application and settings

In order to ensure the full performance of VT Guard Pro and thus reliably protect Voltage transformers against Ferroresonance in all cases, it is recommended that the rated primary voltage of Voltage transformers shall correspond to the highest value of the operating voltage in the grid which occurs under normal environmental conditions at any time and at any point in the system.

a) VT Guard Pro

VT Guard Pro should be connected in open delta configuration of three single-phase VTs, as shown in Fig. 2. Nominal voltage level of the winding used for open-delta configuration should be 100/3 V or 110/3 V.

VTs should further fulfill minimum design parameters:

- thermal limiting output: 400 VA
- rated current of open delta winding: 6 A
- cross-section of open delta winding: 2 mm²

Attention: Manufacturer does not guarantee proper operation and performance of VT Guard Pro in case of its use in different applications or at different voltage levels. In such case contact manufacturer for further details.

In case some other device for ferroresonance elimination is already installed in the open-delta winding of VT, it has to be removed from this circuit before VT Guard Pro installation.

02 Connection diagram of VT Guard Pro

03 Jumper setting

04 Recommend connection of the diagnostic supply

05 Recommend connection of the diagnostic supply

06 Device status, LED position

Live end of the open delta configuration (da1 - terminal on Fig. 2) should be connected into X1:1 terminal, earthed end (dn3 - terminal on Fig. 2 to the X1:2 terminal. In case, the earth-fault protection device is already connected in open delta configuration, the VT Guard Pro should be connected in parallel to such protection device.

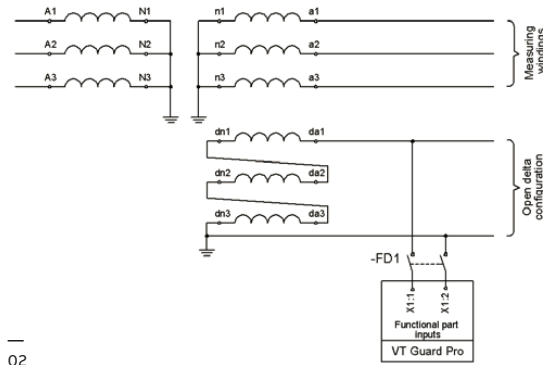

02

Factory default setting for the threshold voltage of VT Guard Pro (effective voltage level when the device is activated) is 20 V and time delay (time between reach of threshold voltage and dumping action – introduced in order to keep functions of external protection device unaffected) is 1.4 s. These settings cover the majority of the applications, but can be changed if necessary. In that case, the device has to be disconnected from the power (both functional and diagnostic part) at least for 20 s before setting change. The setting change is done by jumpers, after opening the cover– one jumper is for threshold voltage selection, the other for time delay.

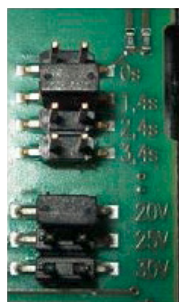

Possible adjustment:
 Threshold voltage 20, 25, 30 V
 Time delay 0.4; 1.4; 2.4; 3.4 s

03

b) VT Guard Pro-D

The internal settings (threshold voltage, time delay) and connection of the functional part (Terminals X1:2, X1:2) should be done the same way as in the case of VT Guard Pro (Fig. 2) Separate power supply is needed for diagnostic part. There are two recommended ways how to supply power to the diagnostic part (described in Fig. 4 and Fig. 5). The earthed star-point (n1, n2, n3) has to be connected to the X2:1 terminal (diagnostic part)

and earthed part of the open delta (dn3) configuration to the terminal X1:2 (functional part), for the connection on Fig. 4.

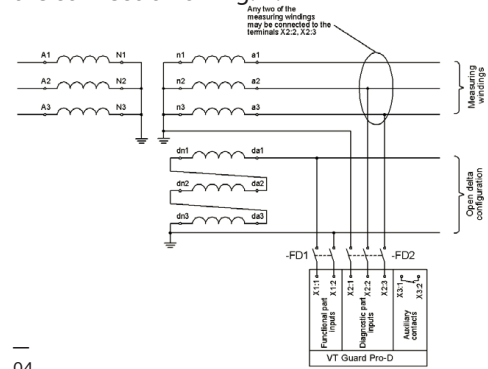

04

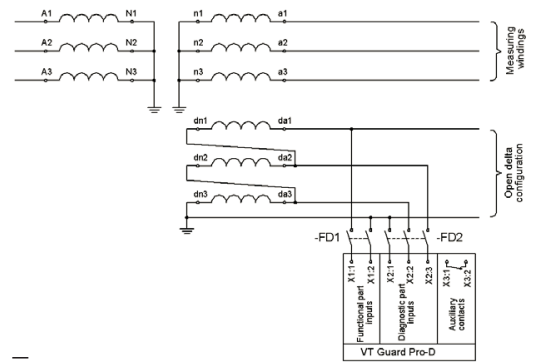

05

The VT Guard-D has self-check functions. The status of the device is indicated by

- Diodes, which are placed in such a way, that they are visible (only when activated) through unused holes at the screw terminal holes on the right side, position 17 - RED, 18 - GREEN

LED indication	Description
RED	GREEN
	- Diagnostic power is OFF
	- Diagnostic power is ON
	- Device OK
x	- Diagnostic power is too low
	- Circuit error occurred
x	x
	- Diagnostic power is too low or circuit error occurred

a) OK



b) internal failure



06

- Terminals X3:1 and X3:2 (see Fig. 4, Fig. 5). In case of proper operation, auxiliary contacts are switched on. Superior system (e.g. protection relay - separate device with available binary inputs/outputs) sends and receives the same signal through these terminals. In case of internal failure, there is no signal flowing through.

3. Instruction for installation

VT Guard Pro should be fitted in low-voltage compartment of the MV switchgear at the DIN – TS 35 rail in vertical position at least 20 cm from other thermal sources. Connection should be done according to the Fig. 4 or Fig. 5 by insulated wires (minimum cross-section should be 1.5 mm², maximum – 2.5 mm²). Maximal length of the connection wires up to 150 m. Minimum temperature wires rating is 75°C! The device should be connected via switches /isolators (-FD1, -FD2) according to (Fig. 2, Fig. 4, Fig. 5) to meet IEC 61010-1 (CE marking). If the switches/isolators are not used it has no impact on the device functionality. The device contains self-protection components which disconnect device in case of internal failure.

- functional (terminals X1:1, X1:2)...-FD1, resistive load AC1, min 15A tripping ability, recommended device - ABB isolator E202
- diagnostic (terminals X2:1, X2:2, X2:3)...-FD2, resistive load AC1, min 1A tripping ability, recommended device - ABB isolator E203

Attention: The switches shall be in close proximity to the device and within easy reach of an operator. The switches shall be marked as the disconnecting device for the equipment.



Device part	Terminal		
	Label	Description	Voltage
Functional	X1:1	open delta configuration - live end	0 - 110 V AC
	X1:2	open delta configuration - earthed end	earthed
Diagnostic	X2:1	measurement/residual winding - earthed	earthed
	X2:2	measurement/residual winding - live end	33 - 110 V AC
	X2:3	measurement/residual winding - live end	33 - 110 V AC
Auxiliary contacts	X3:1	closed in normal condition	230 V AC
	X3:2		220 V DC

Tab. 1 – Terminals position

Attention: All of assembly work should be done after transformers disconnection from network.

It is forbidden to open VT Guard enclosure under voltage or with connected leads from the voltage transformers

It is forbidden to do any manipulation or changes inside of the device, except of jumper setting (Fig. 3). Jumper setting to be done by authorized and trained personnel only.

If the device is used in a manner not specified by the manufacturer, the protection provided by the equipment may be impaired

4. Operating condition

Appliance should be working indoor, with ambient temperature from -25°C to +50°C and humidity up to 90 %, not condensing water.

Note: No one should touch terminals with metallic objects, when appliance is under voltage.

It is forbidden to place any objects close to or into ventilation gaps of the device.

In case of improper work or failure, it is necessary to separate appliance from system and replace with a new device.

5. Technical parameters

Device part	Functional	Rated operational voltage	Ue	100/110 V AC
		Max. operational current	I _{emax}	10 A/0.2s
		Voltage range	U	0-110 V AC
		Nominal frequency	f _n	50/60 Hz
		Time delay	t _d	0.4; 1.4; 2.4; 3.4 s
		Threshold voltage	U _t	20; 25; 30 V
	Selfconsumption	P	<0.1 W	
	Diagnostic	Rated control supply voltage	U _S	100/√3, 100/3 V AC
		Voltage range	U	33-110 V AC
		Nominal frequency	f _n	50/60 Hz
Selfconsumption		P _D	<2 W	
Auxiliary contacts	Rated control circuit voltage	U _C	230 (max. 100 mA) V AC	
			220 (max. 100 mA) V DC	
Operating ambient temperature		-	-25°C ... +50°C	
Storage & transportation temperature		-	-40°C ... +85°C	
Humidity		-	up to 90 %	
Protection class		-	IP 20	

6. Dimensional drawing

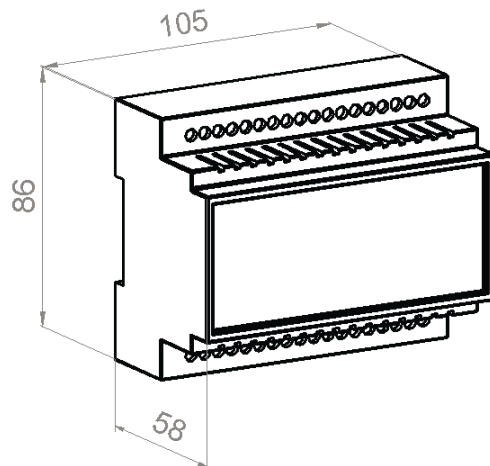

7. Maintenance and service

It is important to keep VT Guard Pro in cleanliness. Special attention should be paid to cleanliness of air-ventilation gaps. In case, of choked air-ventilation gaps the device should be disconnected from the circuit (both functional and diagnostic part), then the air-ventilation gaps can be cleaned by brush or compressed air. Other preventive maintenance is not needed.

Attention:

Any repairs must be done only by authorized personnel.

Manufacturer does not take responsibility for improper device functioning in case of unauthorized servicing.

Choked gaps may cause failure of appliance.

8. Warranty

The manufacturer warranty is 24 months since the day of putting the apparatus into operation but not longer than 36 months since the day of purchase.

9. Disposal

The device contains electronic parts. It should be disposed in electronic-waste recycling centre according to the local law.

CONTACT US

ABB s.r.o.
ELDS Brno
Videnska 117, 619 00 Brno,
Czech Republic
Tel.: +420 547 152 021
+420 547 1528 54
Fax: +420 547 152 626
E-mail: kontakt@cz.abb.com

NOTE

We reserve the right to make technical changes or modify the contents of this document without prior notice. With regard to purchase orders, the agreed particulars shall prevail. ABB does not accept any responsibility whatsoever for potential errors or possible lack of information in this document.

We reserve all rights in this document and in the subject matter and illustrations contained therein. Any reproduction, disclosure to third parties or utilization of its contents - in whole or in parts - is forbidden without prior written consent of ABB.

Copyright© 2022 ABB
All rights reserved