

More colors, less waste

ABB Cartridge Paint System:
Cutting costs and reducing environmental impact
Osamu Yoshida



How many different colors should an automaker offer its customers? A famous pioneer supposedly said, "You can have it in whatever color you want so long as it's black". Today, however, it goes without saying that automakers seek to improve their market position by offering customers as many choices as possible.

But how many choices are possible? Diversity is largely limited by production line logistics. Until now, to change color, the painting apparatus of a robot had to be thoroughly cleaned. This wastes paint and solvent, adds to pollution and costs time and money. All good reasons not to change color more often than is absolutely necessary.

But imagine being able to switch color without losing paint or time, and while reducing solvent waste by more than a factor of ten. With ABB's innovative cartridge bell system, this vision becomes reality.

Demand driven manufacturing

When a modern car gets into a fender-bender, it's increasingly unlikely that the local body shop will bang the bumper back into shape. Neither will the manufacturer pull a spare out of stock; instead a whole new bumper module will be built specifically to meet the individual need.

This saves on inventory costs, but it makes the paint operations at automakers and their subsidiary suppliers far more complex; not only do they need to paint bumpers for current-model cars, but must also be able to paint small lots of replacement parts for older models.

During the normal production run of a car model, some ten colors are required. For a bumper line, however, that number can often be as high as 50 or 60, and consequently the number of units painted in any one color is limited. Even so, an entire paint line has to be operated to ensure the same quality as the original product.

Whether using hand spray guns or robots, long paint supply lines and atomizers must be thoroughly cleaned with solvent between each paint change. Both paint and solvent are wasted, increasing costs and causing negative impact on the environment (particularly solvents, which contain volatile organic compounds, or VOCs, which are a serious source of pollution). Not the most efficient way to produce bumpers – or

any other painted product requiring different paint colors.

The solution came out of an internal brainstorming session. ABB thought that having a traditional paint line with many different paint tanks and all the lines and hoses needed to paint just a few bumpers was a terrible waste not only of paint and solvent, but also of time, labor and money. Why not move the paint tank to the end of the robot arm itself? The total amount of paint needed didn't have to be too much, only 350 to 500 ml, so if a way could be found to put a small tank – a cartridge – on the robot, only the atomizer itself would have to be cleaned with solvent. Each cartridge could be dedicated to one color, so keeping cleaning to a minimum.

As carmakers struggle to position themselves in a highly competitive global market, offering consumers a greater choice in color and features is one way to set themselves apart.

Working closely with a major Japanese automaker, ABB began to pursue the idea – applying it not only to bumpers. As carmakers struggle to po-

sition themselves in a highly competitive global market, offering consumers a greater choice in color and features is one way to set themselves apart.

At the same time, the cartridge concept promised to reduce VOC (volatile organic compounds) emissions and paint waste, an important consideration in a time of increased environmental awareness and tighter legislation. ABB thought the concept might also increase the total efficiency of automotive paint operations. They set a number of goals for the project. One was to practically eliminate paint and solvent loss caused by paint change. The other was to reduce material loss at color change from approximately 120 ml of solvent and 32 ml of paint to just 10 ml of solvent: the amount needed to clean the bell cup.

There were several initial technical hurdles that had to be overcome. First was that the time for a cartridge change had to be 10 seconds or less. If this could not be achieved, painting operations would have to slow down – not an option for automakers!

Next was the question of how to hold the cartridge in place in the robot arm. Vacuum pressure was the obvious answer, but it had to be very carefully controlled.

To increase coating efficiency and reduce paint loss, paint robots use elec-

1 ABB's cartridge bell system (CBS). The proximity of the paint to the bell cup minimizes paint and solvent loss when the color is changed

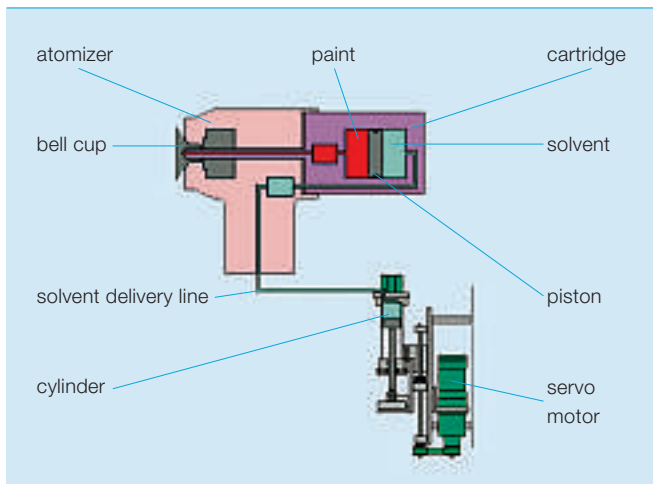

2 A paint robot changing its cartridge in the manipulator. The empty cartridge is automatically refilled



Demand driven manufacturing

trostatic painting. In traditional hand painting, only a small part of the paint actually adheres to the body – often as little as 20 percent. ABB is the inventor of, and world leader in electrostatic painting. This technique greatly increases the transfer efficiency of the painting process. A negative electrical charge is applied to the paint droplets as they emerge from the atomizer; the car body is grounded. The result is that the paint is not simply sprayed onto the car body, but is actually attracted to it electrically. The major issue raised by this method is sparking. A spark can easily ignite the flammable mixture of vaporized paint and solvent and air. The developers had to find the ideal pressure to hold the cartridge in the robot arm. Too much of a vacuum would have led to sparking.

As these hurdles were cleared, a working concept began to develop.

A conventional robot painting systems involves large tanks for the main color, smaller tanks for special colors, a tank for solvent, paint supply lines leading to a Color Change Valve unit (CCV), and a Flushable Gear Pump unit (FGP) mounted on the robot to regulate paint flow. They all have to be cleaned for paint changes. In the new concept **1** the robot was to be separated from the paint delivery system. There would still be paint and solvent tanks, albeit much smaller for special colors. These would feed to a cartridge handling unit, where the paint would be filled into the cartridges. Each cartridge would contain a piston driven by solvent to force out the paint as painting progressed. A full cartridge would contain only paint below the piston, and no solvent; as solvent was pumped into the cartridge, the paint would be driven out, until the piston was fully extended with only solvent above it. The robot required only a solvent-filling line; all other lines

3 An ABB technician inspects a CBS installation



would be single-usage and lead only to the cartridge station. A surprisingly simple and straightforward idea! At least, as an initial concept.

The cartridge change time requirement made the supply and the removal of solvent in the cartridge an important issue to overcome. What was desired was an almost instantaneous and constant delivery of solvent to the cartridge, resulting in a similarly constant and smooth delivery of paint, with both varying by less than ± 10 ml during the painting operation.

The solution was fairly straightforward, involving the addition of a third valve to the solvent control unit and modifying the shape of the cylinder head inside the cartridge. The result was flow of both solvent and paint from stop to full flow in less than 0.2 seconds, with flow that varied by only ± 3 ml – far below the target figure. This was better than the devel-

opment team expected, and it really made the system very attractive for the market.

First realized in the late 1990s, the system – now called the Cartridge Bell System (CBS) – is being applied on automotive production lines not only in Japan, but also in Asia, the US and Europe. As intended, it is a streamlined approach to painting. The exchange unit can be flexibly adjusted with as many colors as needed **2**, with two cartridges for each color (one being filled while the second is in use). When a cartridge is empty, the robot arm swings over to pick up a newly filled cartridge **3**, set in place by the cartridge handler and held in place by the robot using negative air pressure.

In the meantime, the first cartridge is being filled. The solvent from above the piston is used to prepare fresh paint. When the time for a color change has come, only the atomizer bell is cleaned with solvent; the robot then

simply begins to work using a different pair of cartridges.

Significantly, this approach leads to safer electrostatic painting, because only the cartridge itself needs to be charged and isolated from ground – no small concern with a charge of -90 kV. Up to 90 percent of all the paint is transferred to the automobile body, hugely cutting paint losses. And small-lot paint runs are far easier to handle, and much more efficient and affordable.

The results from a major Japanese automaker speak for themselves:

- A 27-percent reduction in running costs – a savings of ¥3 billion/US\$ 26 million – over the manufacturer's annual production of five million vehicles.
- A 45-percent reduction in VOC emissions during painting, from 65 grams to 35 grams per square meters.

Demand driven manufacturing

4 The pattern control (PC) bell small (left) and large (right)

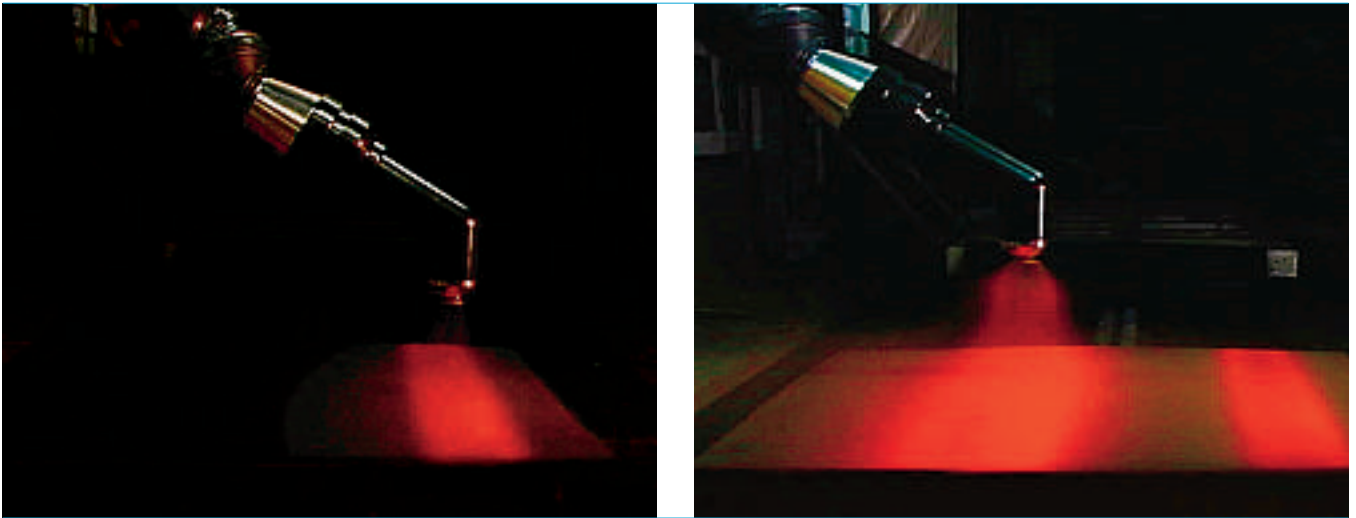

- Improved productivity, with smaller runs of greater numbers of colors, and the possibility of paint-to-order production.

As environmental regulations have become more stringent in recent years, car manufacturers are obliged to switch to waterborne, rather than solvent-borne, paints. Water, naturally, is the ideal solvent, non-polluting and safe to handle. The major problem in the use of waterborne paints comes from the difficulty in utilizing electrostatic painting technologies. Waterborne paints are much more viscous than solvent-based ones, making them harder to vaporize (yet, on the car body, they also tend to remain wet and run more, since water is not as volatile as solvent). Water is also more electrically conductive than solvent. The charged paint supply system must be isolated from the ground, resulting in a system that can be hard to maintain and is potentially dangerous. The result was that electrostatic painting with waterborne paints was impossible for many years.

To cope with this, ABB developed the COPES-IV Bell Atomizer. A bell atomizer has a cup shaped part, the bell, which spins rapidly, flinging the paint off and creating a fine mist that provides superior coating properties. Compressed air spins the bell and shapes the paint mist. ABB engineers succeeded in fitting the COPES-IV with external electrodes that indirectly

charge the paint particles, making electrostatic painting with waterborne paints possible. This type of atomizer, exemplified today by ABB's G1 COPES bell, is now used by European automakers, where stricter EU environmental laws significantly increasing the rate of conversion to waterborne paints.

ABB engineers succeeded in fitting the COPES-IV with external electrodes that indirectly charge the paint particles, making electrostatic painting with waterborne paints possible.

ABB robotic paint solutions are continuously evolving to meet market demands for lower investment, maintenance and operating costs and reduced environmental impact. One variation of the CBS system is the Flushable Cartridge Bell System (FCBS), which provides reduced maintenance costs. Especially when used with waterborne paints, where the problems associated with cleaning by solvent are eliminated, the system allows the cartridge to be cleaned during operations, cutting on routine overhaul of the cartridges. The FCBS has been highly regarded, again particularly in Europe where waterborne

paints are today the norm in automobile production. Japanese and Asian auto production has not been as swift to move to waterborne paint, but there are plans to remedy this in the coming years. At the cutting edge of paint transfer technology is the Pattern Control (PC) bell 4. Automobiles and other objects to be painted do not only consist of open, flat surfaces, but have pillars and other smaller surfaces alternating with wider spaces such as hoods and doors. The PC bell allows for on-the-fly changes in paint spray width – narrow on a pillar and broad for the hood, for example – providing outstanding control of the amount of paint being applied. Combined with ABB robots, this is the future of robotized painting guaranteeing maximum transfer efficiency with minimum paint consumption.

ABB Paint Technologies makes it much easier to be a bumper manufacturer – or an automaker, a white-goods manufacturer or any other operation requiring paint color variation and greater response to individual demands – thanks to ABB Paint Technologies.

Osamu Yoshida
 ABB Automation Manufacturing
 Tokyo, Japan
 osamu.yoshida@jp.abb.com