

# Insertion-Type Electromagnetic Probe Flowmeter

AquaProbe 2



## The Company

We are an established world force in the design and manufacture of instrumentation for industrial process control, flow measurement, gas and liquid analysis and environmental applications.

As a part of ABB, a world leader in process automation technology, we offer customers application expertise, service and support worldwide.

We are committed to teamwork, high quality manufacturing, advanced technology and unrivalled service and support.

The quality, accuracy and performance of the Company's products result from over 100 years experience, combined with a continuous program of innovative design and development to incorporate the latest technology.

The UKAS Calibration Laboratory No. 0255 is just one of the ten flow calibration plants operated by the Company and is indicative of our dedication to quality and accuracy.

EN ISO 9001:2000



Cert. No. Q 05907

EN 29001 (ISO 9001)



Lenno, Italy – Cert. No. 9/90A

Stonehouse, U.K.



## Electrical Safety

This equipment complies with the requirements of CEI/IEC 61010-1:2001-2 'Safety Requirements for Electrical Equipment for Measurement, Control and Laboratory Use'. If the equipment is used in a manner NOT specified by the Company, the protection provided by the equipment may be impaired.

## Symbols

One or more of the following symbols may appear on the equipment labelling:

	<b>Warning</b> – Refer to the manual for instructions		Direct current supply only
	<b>Caution</b> – Risk of electric shock		Alternating current supply only
	Protective earth (ground) terminal		Both direct and alternating current supply
	Earth (ground) terminal		The equipment is protected through double insulation

Information in this manual is intended only to assist our customers in the efficient operation of our equipment. Use of this manual for any other purpose is specifically prohibited and its contents are not to be reproduced in full or part without prior approval of the Technical Publications Department.

### Health and Safety

To ensure that our products are safe and without risk to health, the following points must be noted:

1. The relevant sections of these instructions must be read carefully before proceeding.
2. Warning labels on containers and packages must be observed.
3. Installation, operation, maintenance and servicing must only be carried out by suitably trained personnel and in accordance with the information given.
4. Normal safety precautions must be taken to avoid the possibility of an accident occurring when operating in conditions of high pressure and/or temperature.
5. Chemicals must be stored away from heat, protected from temperature extremes and powders kept dry. Normal safe handling procedures must be used.
6. When disposing of chemicals ensure that no two chemicals are mixed.

Safety advice concerning the use of the equipment described in this manual or any relevant hazard data sheets (where applicable) may be obtained from the Company address on the back cover, together with servicing and spares information.

# Contents

<b>1</b>	<b>Introduction .....</b>	<b>3</b>
1.1	System Schematic .....	3
<b>2</b>	<b>Mechanical Installation .....</b>	<b>4</b>
2.1	Location – Environmental Conditions .....	4
2.1.1	AquaProbe .....	4
2.1.2	Transmitter .....	5
2.2	Location – Flow Conditions .....	6
2.2.1	International Standard for Flow Measurement .....	6
2.2.2	Velocity Limitations .....	7
2.3	Location – Mechanical .....	9
2.3.1	AquaProbe .....	9
2.3.2	Transmitter .....	10
2.4	Safety .....	11
2.5	Installing the AquaProbe .....	12
2.6	Setting the Insertion Depth .....	13
2.6.1	Centre Line Method for Pipe Diameters $\leq 1\text{m}$ ( $\leq 40\text{in}$ ) .....	13
2.6.2	Centre Line Method for Pipe Diameters $> 1\text{m}$ $\leq 2\text{m}$ ( $> 40\text{in}$ $\leq 80\text{in}$ ) .....	14
2.6.3	Mean Axial Velocity Method .....	15
2.7	AquaProbe Alignment .....	16
<b>3</b>	<b>Electrical Installation .....</b>	<b>17</b>
3.1	Connections .....	17
3.1.1	Sensor Terminal Box Connections (Remote Versions only) .....	17
3.1.2	Environmental Protection .....	18
3.1.3	Transmitter Connections .....	19
3.2	Input/Output Connections .....	21
3.2.1	Frequency Outputs .....	21
3.2.2	PLC Interface .....	22
3.2.3	MIL Connector Input/Output Connections (Option) .....	23
3.2.4	Local Computer Connection .....	24
3.2.5	Remote Computer Connection (Option) .....	25
3.2.6	Power Supply Connection Options .....	26
3.2.7	Pressure Transducer (Optional) .....	28
3.2.8	Environmental Protection (Option) .....	29
<b>4</b>	<b>Setting Up .....</b>	<b>30</b>
4.1	Introduction .....	30
4.2	Centre Line Method .....	30
4.3	Mean Axial Velocity Method (1/8 Diameter) .....	31
4.4	Partial Velocity Traverse .....	31
4.5	AquaProbe Transmitter Setup .....	31

---

<b>5</b>	<b>Start Up And Operation</b>	<b>32</b>
5.1	Fitting the Battery	32
5.2	Start-up	32
5.3	Display Activation	33
5.4	Replacing the Battery	34
<b>Appendix A</b>		<b>35</b>
A.1	Testing the Flow Profile for Symmetry	35
A.1.1	Partial Velocity Traverse	35
A.1.2	Single Entry Point Method	35
A.1.3	Dual Entry Point Method	36
<b>Appendix B Aquamaster Block Diagram</b>		<b>37</b>
<b>Notes</b>		<b>38</b>

## 1 Introduction

The AquaProbe electromagnetic insertion flowmeter is designed for measurement of the velocity of water. The flowmeter, available in four standard lengths, can be installed in any pipeline of internal diameter from 200mm (8in) to 8000mm (360in), through a small tapping. The AquaProbe is designed for use in survey applications such as leakage monitoring and network analysis and in permanent locations where cost or space limitations preclude the use of conventional closed pipe meters.

**Note.**

The tip of the AquaProbe is a precision-built part of the equipment and must be handled with care. When the AquaProbe is not in use, fully retract the tip of the probe and replace the end-cap. When removing/inserting the probe into the pipeline, ensure that the valve is fully open. Damage to the probe affects the performance. Physical damage to the probe invalidates the warranty.

### 1.1 System Schematic

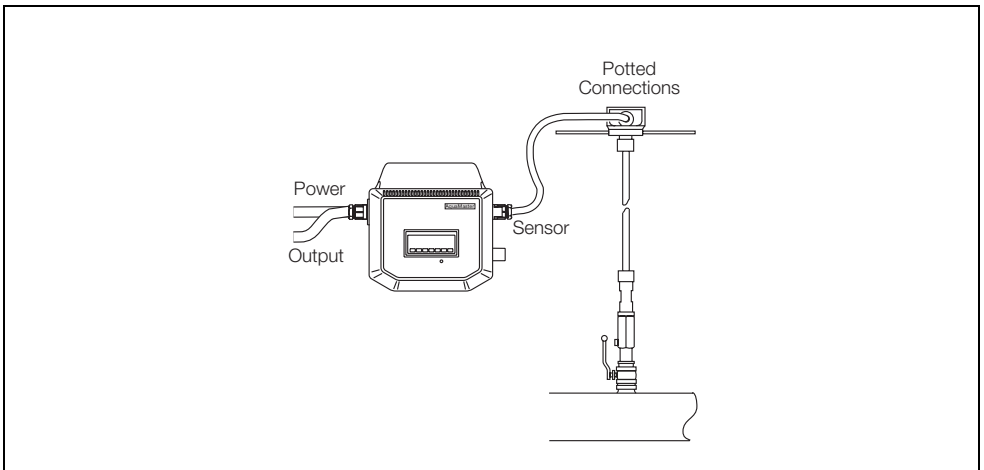

Fig. 1.1 System Schematic

## 2 Mechanical Installation

### 2.1 Location – Environmental Conditions

#### 2.1.1 AquaProbe

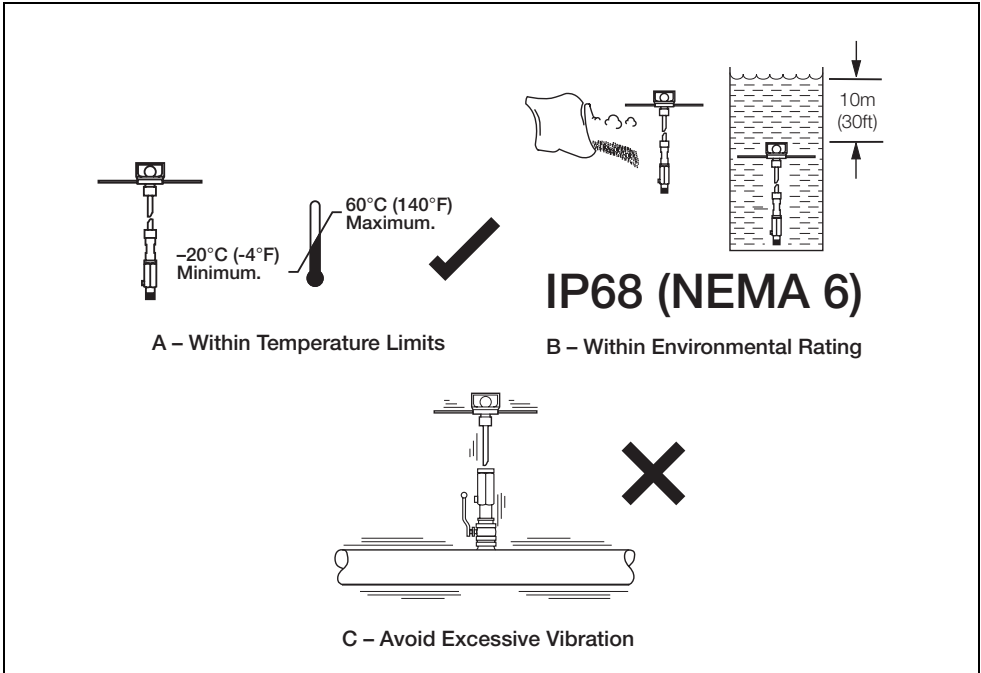

Fig. 2.1 Environmental Requirements – AquaProbe

### 2.1.2 Transmitter

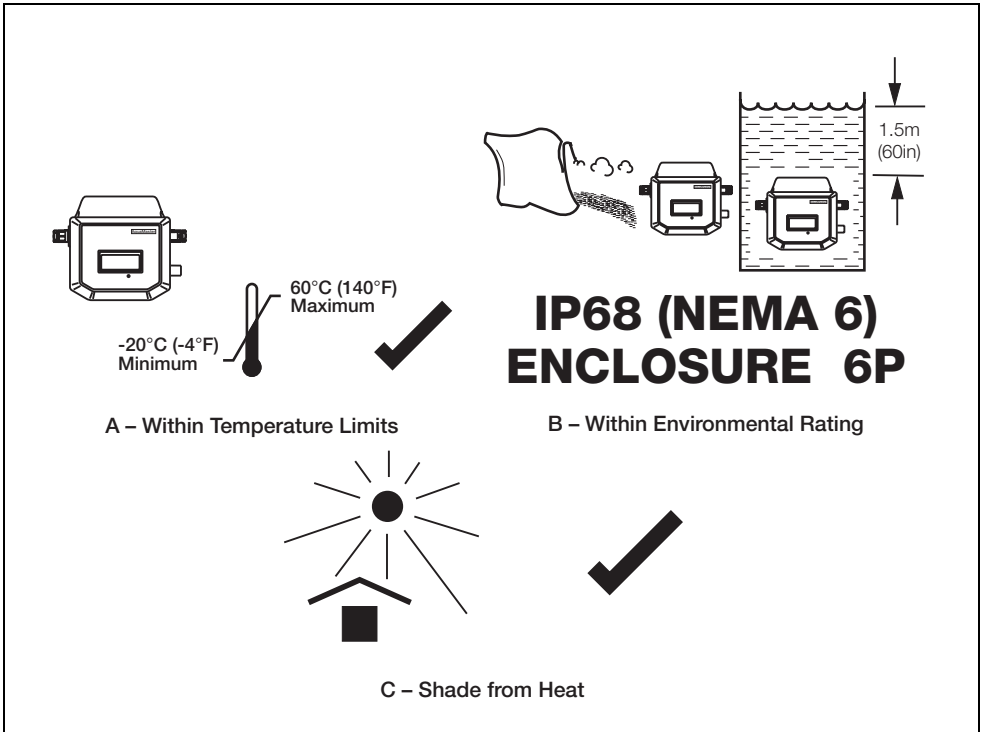

Fig. 2.2 Environmental Requirements – AquaMaster Transmitter

## 2.2 Location – Flow Conditions

The probe may be installed in one of two positions in the pipe; either on the centre line or at the mean axial velocity point (1/8 pipe diameter). It may also be traversed across the pipe to determine the velocity profile.

**Note.** Ensure that the sensor is installed in the pipe with the flow direction arrow on the probe case matching the pipe flow.

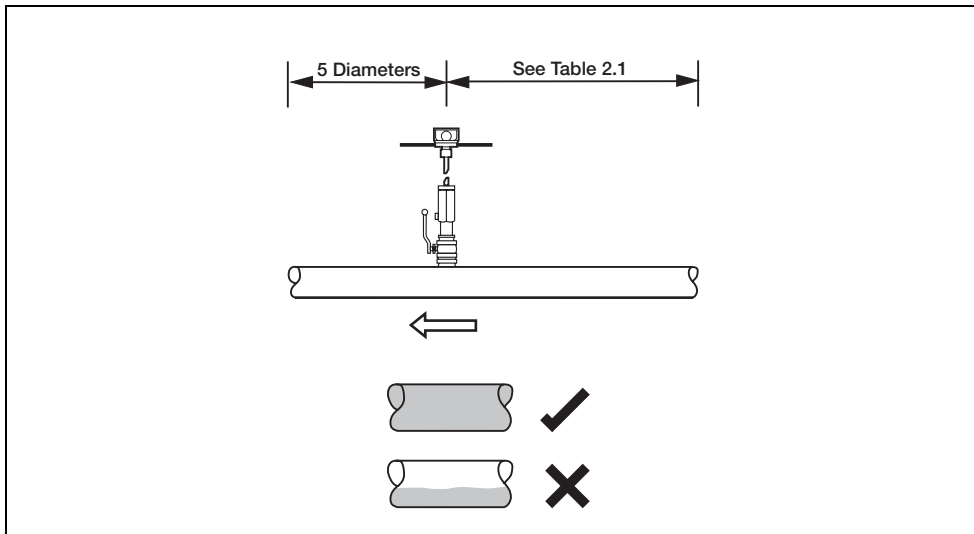

Fig. 2.3 Flow Conditions

### 2.2.1 International Standard for Flow Measurement

ISO 7145 '(BS 1042) Measurement of fluid flow in closed conduits' Part 2 'Velocity area methods' describes methods of calculating volumetric flow from velocity measurements.

Section 2.2: 1982 'Method of measurement of velocity at one point of a conduit of circular cross section' describes the inference of volumetric flow from measurement of velocity at a single point. Several conditions must be fulfilled to validate the method, which uses calculations based on empirical data.

Where the validating conditions can be met, the method described in Section 2.2 is the most practical. It is possible to measure the velocity either on the centre line, which reduces sensitivity to positional errors, or at the assumed point of mean flow velocity.

Table 2.1 is an extract from ISO 7145 (BS 1042): Section 2.2: 1982 and is reproduced with the permission of BSI. Complete copies of the standard can be obtained by post from BSI Publications, Linford Wood, Milton Keynes, MK14 6LE.

**Note.** Where the above ideal conditions cannot be achieved, the flow profile must be tested for symmetry in order to obtain reliable flow results.



Type of disturbance upstream from the measuring cross-section	Minimum upstream straight length*	
	For a measurement at the point of mean axial velocity	For a measurement on the axis of the conduit
90° elbow or a t-bend	50	25
Several 90° coplanar bends	50	25
Several 90° non- coplanar bends	80	50
Total angle convergent 18 to 36°	30	10
Total angle divergent 14 to 28°	55	25
Fully opened butterfly valve	45	25
Fully opened plug valve	30	15

\* Expressed in multiples of the diameter of the conduit.

Downstream from the measurement cross-section, the straight length shall be at least equal to five duct diameters whatever the type of disturbance.

Table 2.1 Straight Pipe Lengths

### 2.2.2 Velocity Limitations

All insertion probe devices are susceptible to the vortex shedding effect which can cause severe vibration of the probe, resulting in damage and/or measurement instability. Electromagnetic devices with no moving parts, such as AquaProbe, are less susceptible to this effect than mechanical devices.

The graphs below show the maximum permissible velocities, depending on the probe's location.

This information is provided as a guide only. Some installations may experience unwanted vibration resonance which may further limit the maximum velocity at which the AquaProbe may be used.

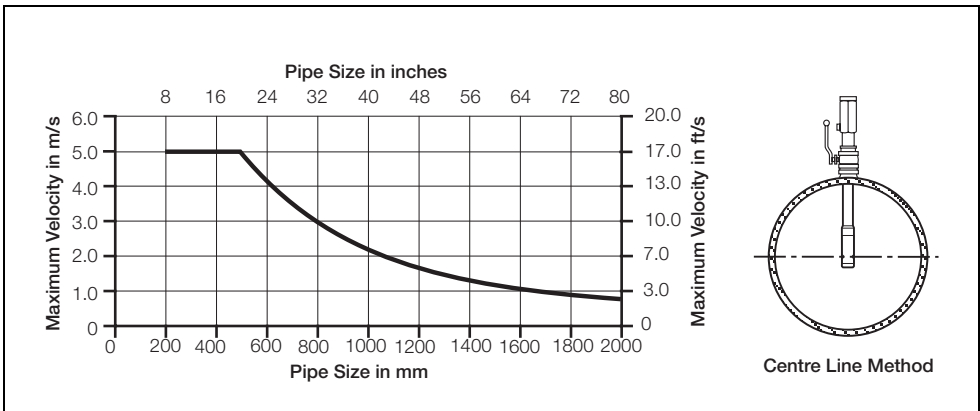

Fig. 2.4 Maximum Permissible Velocity for different Pipe Sizes

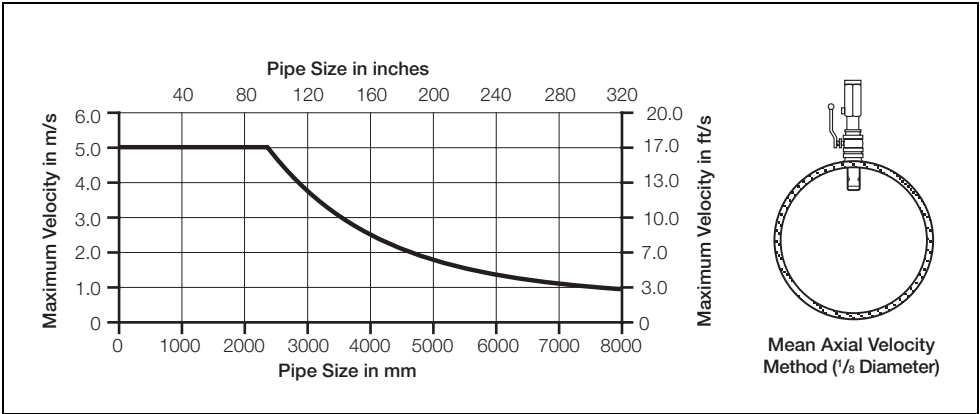

Fig. 2.5 Maximum Permissible Velocity for different Pipe Sizes

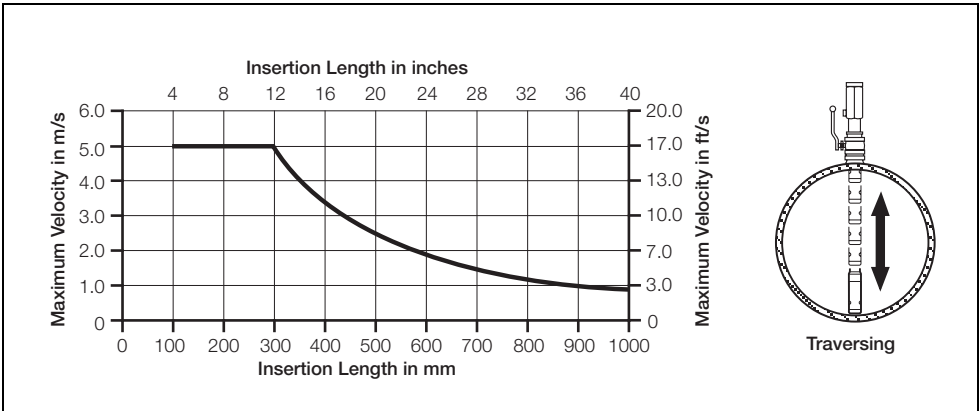

Fig. 2.6 Maximum Permissible Velocity for different Insertion Lengths

## 2.3 Location – Mechanical

### 2.3.1 AquaProbe

**Note.** Pipeline recommended to be metal for electrical screening.

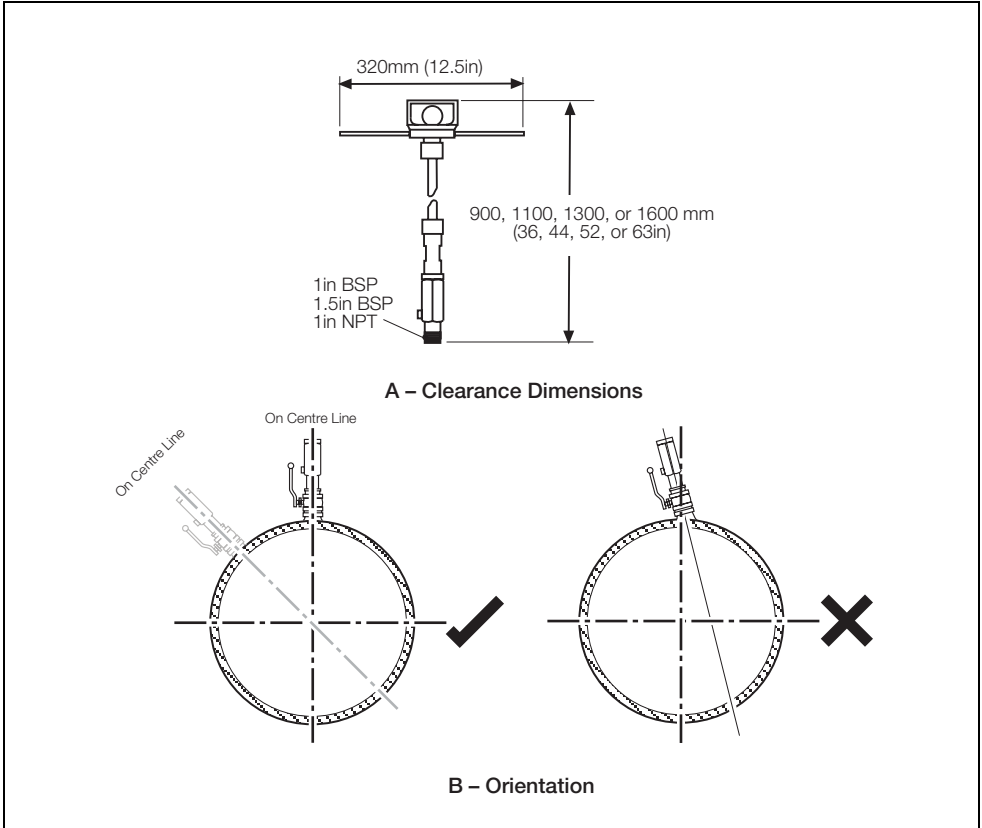

Fig. 2.7 Mechanical Requirements – AquaProbe

### 2.3.2 Transmitter

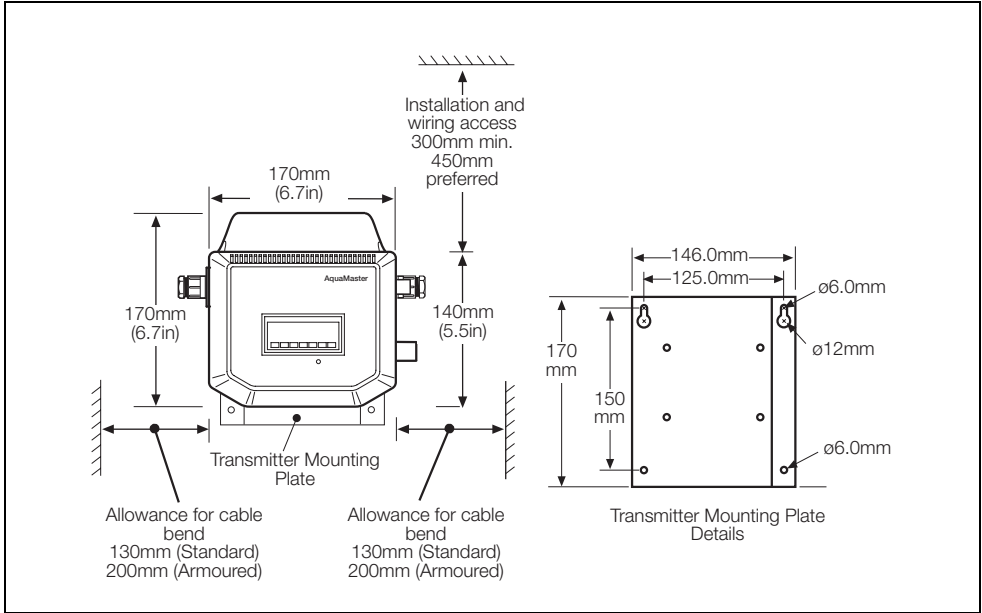

Fig. 2.8 Clearance Dimensions – Transmitter

## 2.4 Safety

**Warning.** The Aquaprobe is provided with a safety mechanism (see Fig. 2.9A ) which should be attached to its securing collar as shown in Fig. 2.9B. This prevents rapid outward movement by the probe if the nut 1 is released.

**Note.** To ensure maximum safety, the positioning collar **MUST** be tightened in place using a 4mm hexagon key

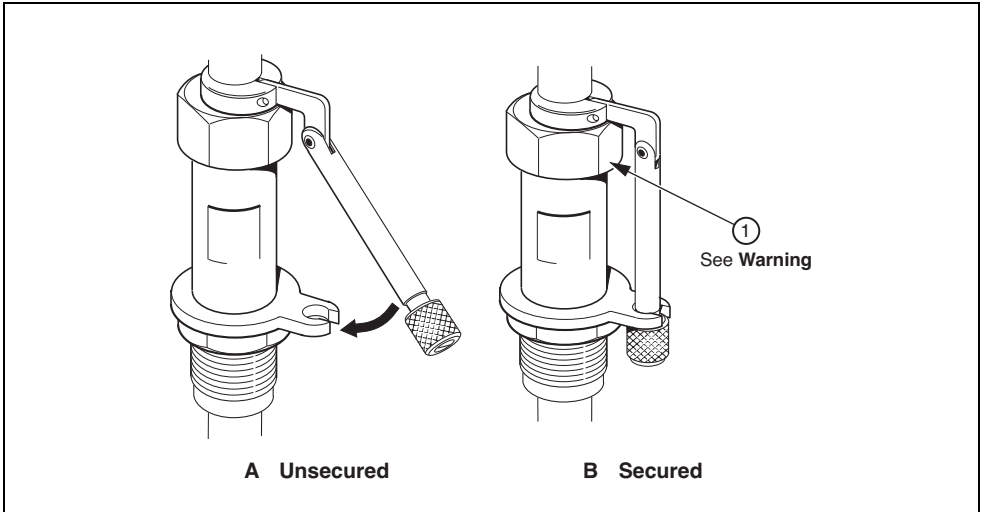

Fig. 2.9 Safety Mechanism

## 2.5 Installing the AquaProbe

**Warning.** When inserting or removing the AquaProbe suitable restraining equipment must be used to prevent the probe being forced out under pressure. Ensure that the valve is fully open.

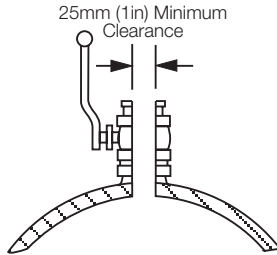

Fig. 2.10 Insertion Bore Clearance

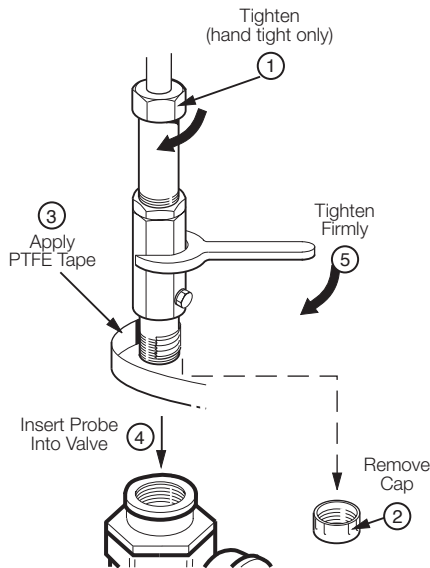

Fig. 2.11 Installing the AquaProbe

## 2.6 Setting the Insertion Depth

### 2.6.1 Centre Line Method for Pipe Diameters $\leq 1\text{m}$ ( $\leq 40\text{in}$ )

**Warning.** When inserting or removing the AquaProbe suitable restraining equipment must be used to prevent the probe being forced out under pressure. Ensure that the valve is fully open.

**Note.** Safety restraint omitted for clarity.

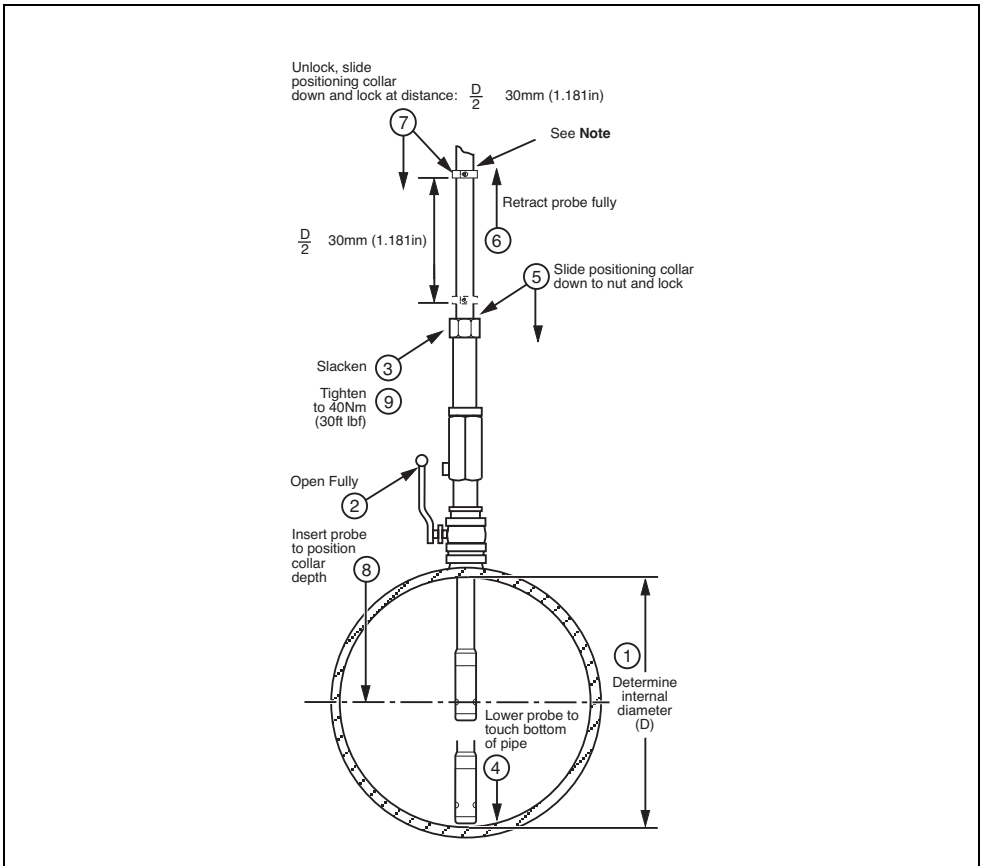

Fig. 2.12 Setting the insertion Depth – Centre Line Method for Pipe Diameters 1m (40in)

### 2.6.2 Centre Line Method for Pipe Diameters >1m ≤2m (>40in ≤80in)

**Warning.** When inserting or removing the AquaProbe suitable restraining equipment must be used to prevent the probe being forced out under pressure. Ensure that the valve is fully open.

**Note.** Safety restraint omitted for clarity.

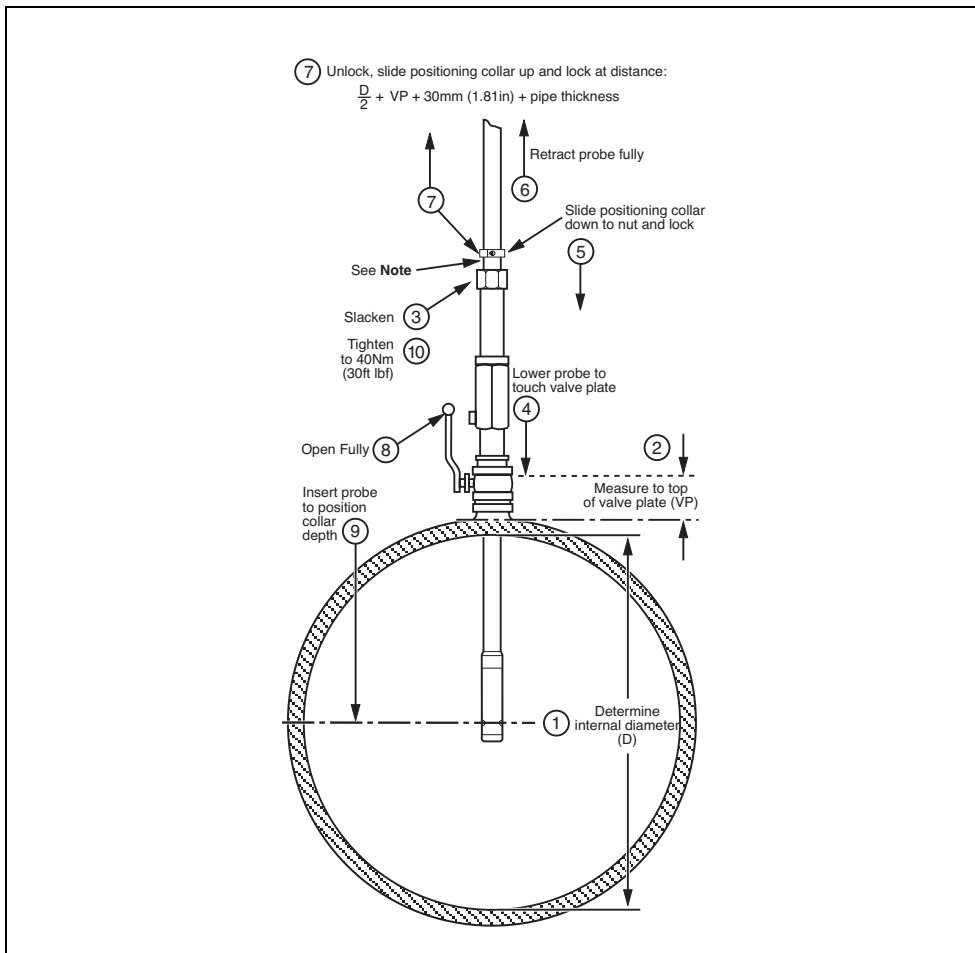

Fig. 2.13 Setting the Insertion Depth – Centre Line Method for Pipe Diameters >1m 2m (>40in 80in)



### 2.6.3 Mean Axial Velocity Method

**Warning.** When inserting or removing the AquaProbe suitable restraining equipment must be used to prevent the probe being forced out under pressure. Ensure that the valve is fully open.

**Note.** Safety restraint omitted for clarity.

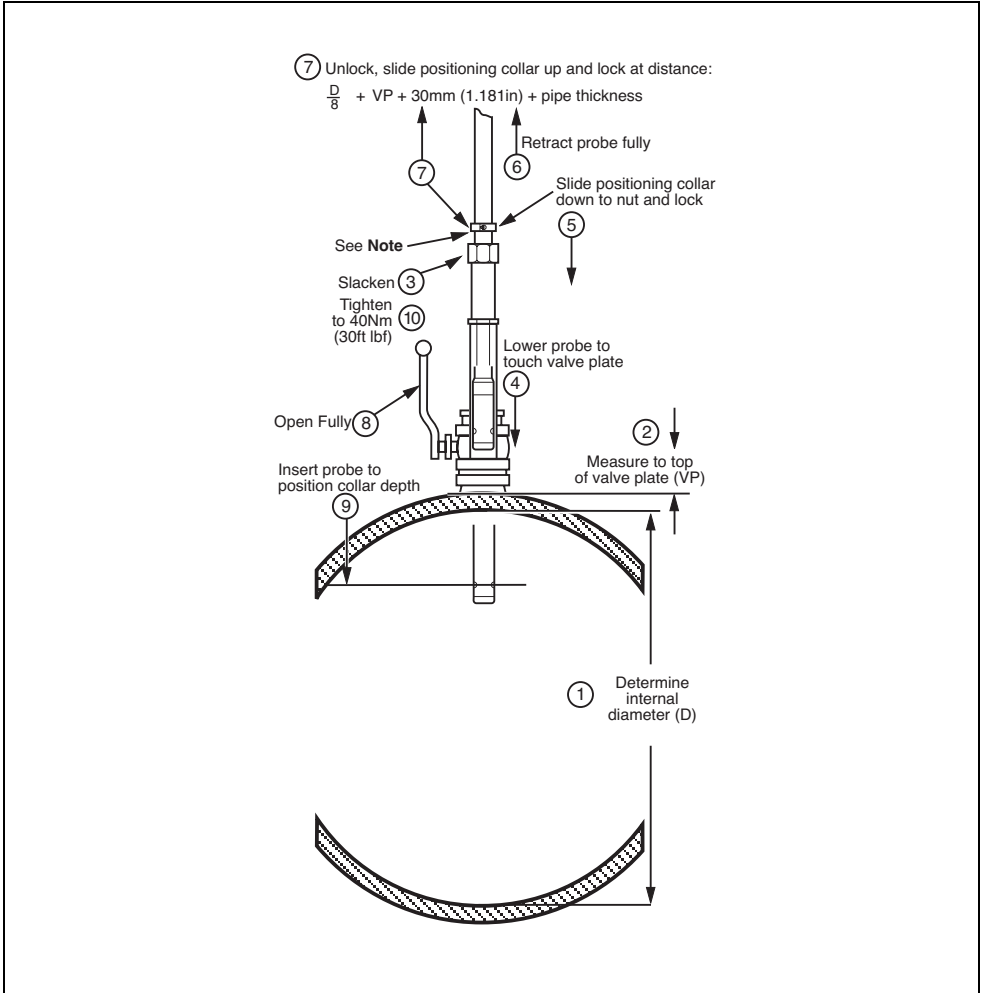

Fig. 2.14 Setting the Insertion Depth – Mean Axial Velocity Method

## 2.7 AquaProbe Alignment

**Warning.** When inserting or removing the AquaProbe suitable restraining equipment must be used to prevent the probe being forced out under pressure. Ensure that the valve is fully open.

**Note.** Safety restraint omitted for clarity.

**Note.** Measurement error due to misalignment (of  $<2^\circ$ ) is  $<0.15\%$ .

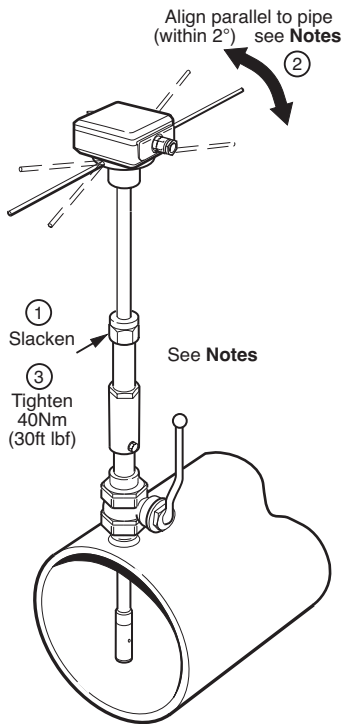

Fig. 2.15 Probe Alignment

### 3 Electrical Installation

#### 3.1 Connections

##### 3.1.1 Sensor Terminal Box Connections (Remote Versions only)

**Caution.** (Remote versions)

- Make connections only as shown.
- Remove foil screens
- Twist the three screen wires together and sleeve them.
- Twist cable pairs together
- Maintain Environmental Protection at all times.
- Conduit connections must provide cable entry sealing.

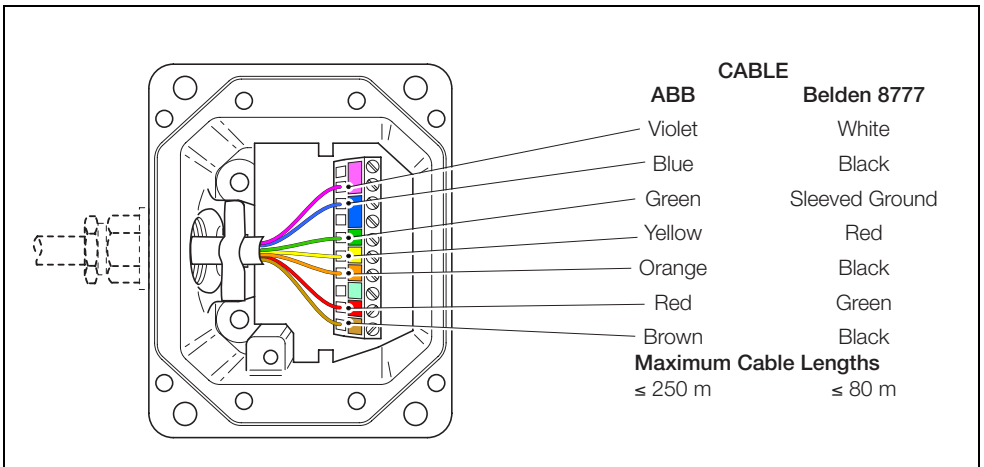

Fig. 3.1 Sensor Terminal Box Connections (Remote Version)

**Caution.** With Belden Cable 8777, ensure that the black wires are not interchanged, and remain with the associated twisted pair.

### 3.1.2 Environmental Protection

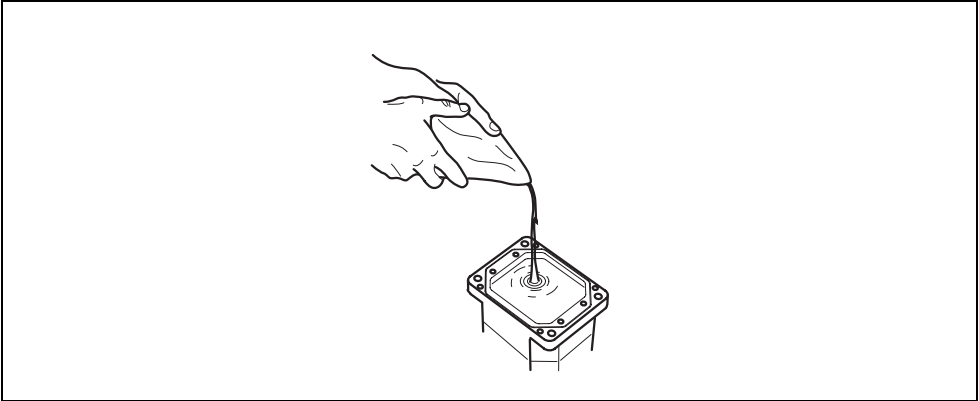

Fig. 3.2 Potting the Terminal Box

#### Warning.

- Potting materials are toxic – use suitable safety precautions.
- Read the manufacturers instructions carefully before preparing the potting material.
- The remote sensor terminal box connections must be potted immediately on completion to prevent the ingress of moisture.
- Check all connections before potting – see section 3, page 17.
- Do not overfill or allow the potting material to come into contact with 'O' rings or grooves.
- Do not let potting material enter conduit, if used.

### 3.1.3 Transmitter Connections

**Caution.**

- To ensure cable glands seal, use cable of diameter 7 to 11mm (0.28 to 0.43 in) only.
- Ensure cable glands are tightened after wiring.
- Ensure that 'O' ring seals and mating surfaces are clean, to maintain environmental rating.

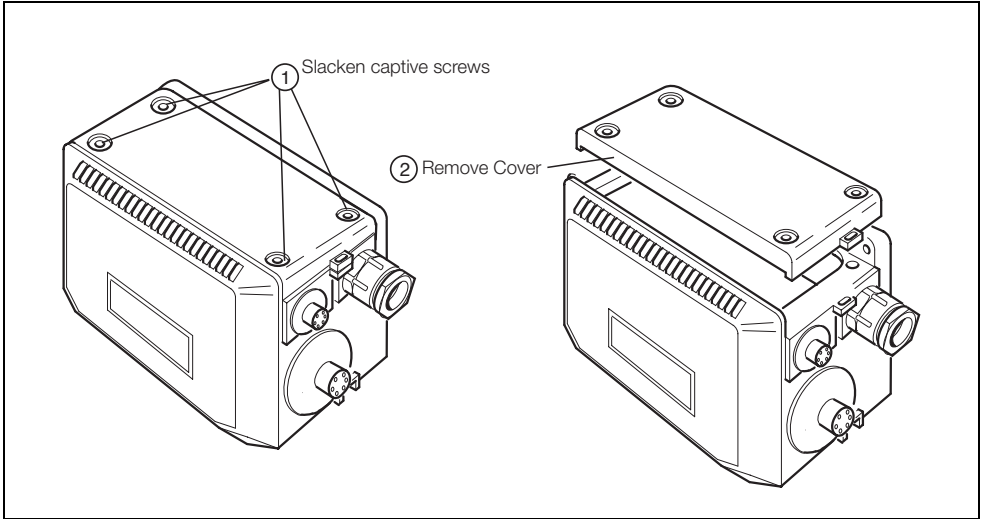

Fig. 3.3 Transmitter Connection Terminal Access

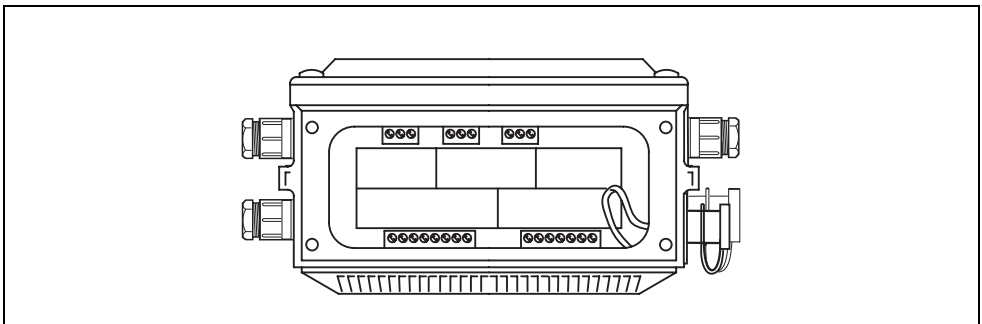

Fig. 3.4 Transmitter Connection (Glands/Conduit Entry)

**Caution.** (Remote versions)

- Make connections only as shown.
- Remove foil screens
- Twist the three screen wires together and sleeve them.
- Twist cable pairs together
- Maintain Environmental Protection at all times.
- Conduit connections must provide cable entry sealing.

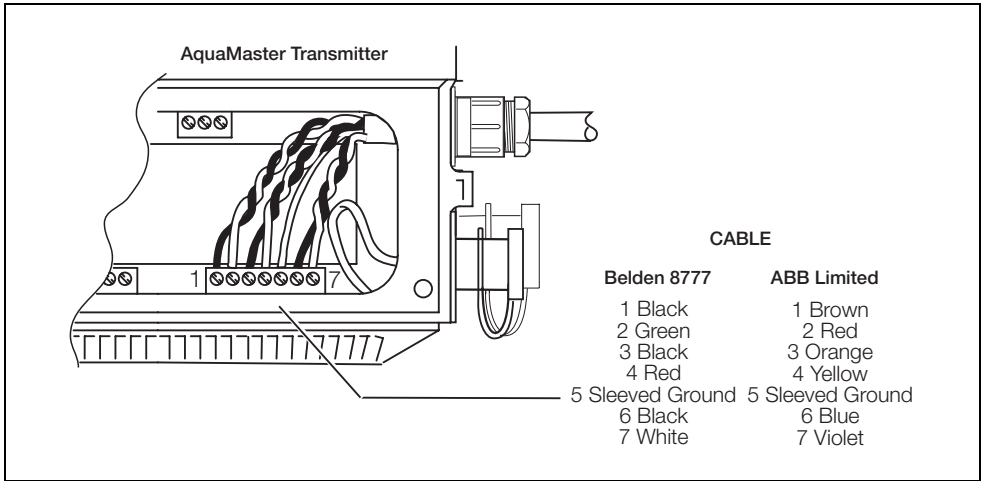

Fig. 3.5 Sensor Cable Connections (Gland/Conduit, Remote version)

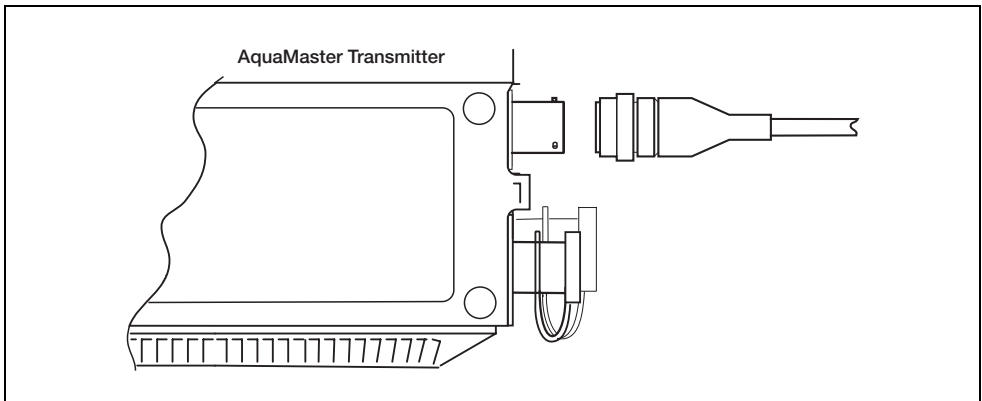

Fig. 3.6 Sensor Cable Connections (Connector, Remote version)

**Note.** This arrangement is an option.

### 3.2 Input/Output Connections

**Caution.**

- Refer to SPECIFICATION SHEET for Input/Output ratings.
- Inductive loads must be suppressed or clamped to limit voltage swings
- Capacitive loads must be inrush current limited.

#### 3.2.1 Frequency Outputs

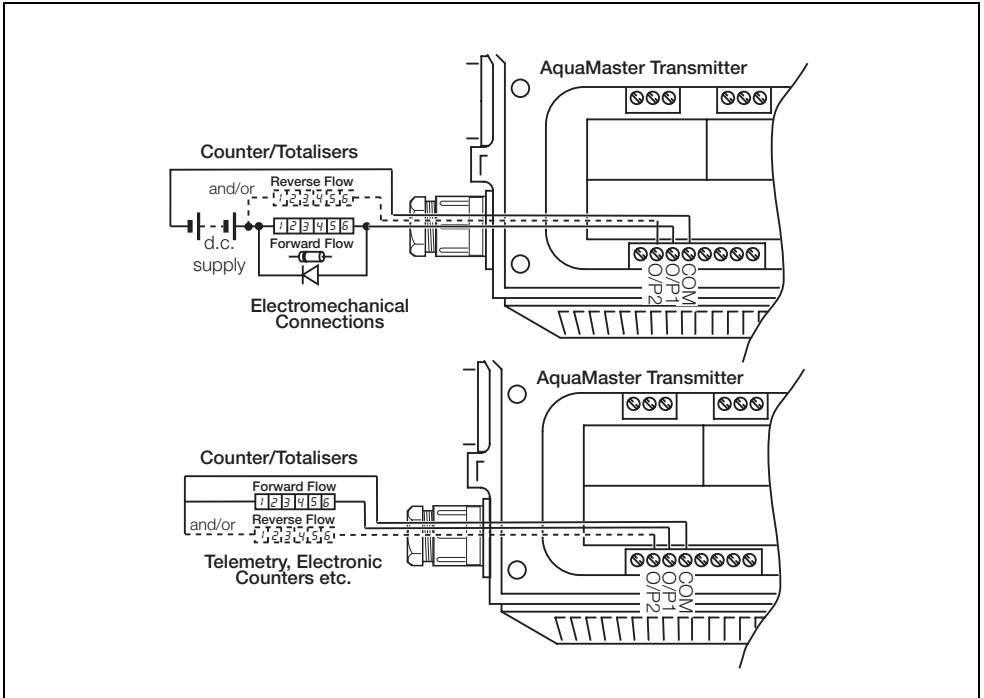

Fig. 3.7 Frequency Output Connections

**Note.** Outputs 1, 2 & 3 are not polarity sensitive. The common connection for these outputs is designated 'COM'.

### 3.2.2 PLC Interface

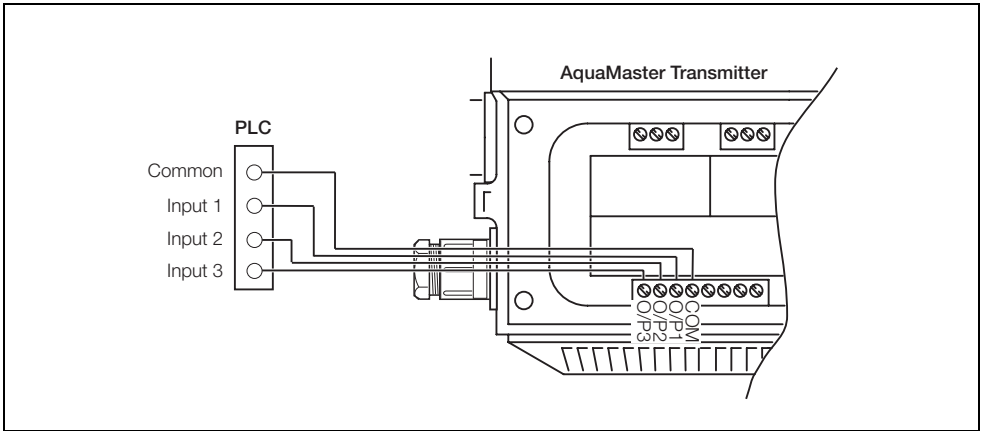

Fig. 3.8 Frequency and Alarm Output Connections

**Note.** Outputs 1, 2 & 3 are not polarity sensitive. The common connection for these outputs is designated 'COM'. Output 3 is an option and may not function on some models.



### 3.2.3 MIL Connector Input/Output Connections (Option)

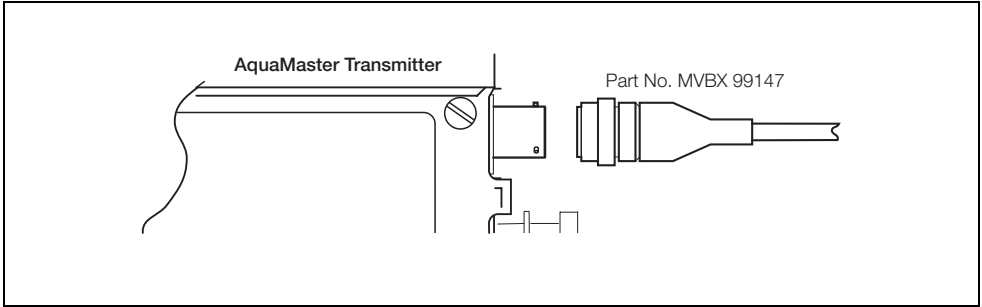

Fig. 3.9 MIL Connector Connections

Pin	Name	Function	Colour (Output cable)
A	-	Reserved	
B	-	Reserved	
C	-	Reserved	
D	O/P 1	Forward Pulses	Orange
E	O/P 3	Output 3	White/Orange
F	O/P 2	Reverse Pulses or Direction	Blue
G	O/P Com	Common	Drain Wire
H	-	Reserved	
J	I/P Gnd	Input Common	White
K	I/P+	Contact Input	Violet
L	RXD	Receive data (serial input connection)	Turquoise
M	TXD	Transmit data (serial output connection)	Brown
N	RTS	Request to send	Red/Black
P	CTS	Clear to send	Yellow/Red
R	-	Reserved	
S	-	Reserved	
T	RI	Ring Indicator	Yellow
U	-	Reserved	
V	Serial GND	Comms Ground	Green

Table 3.1 MIL Connector Connections

### 3.2.4 Local Computer Connection

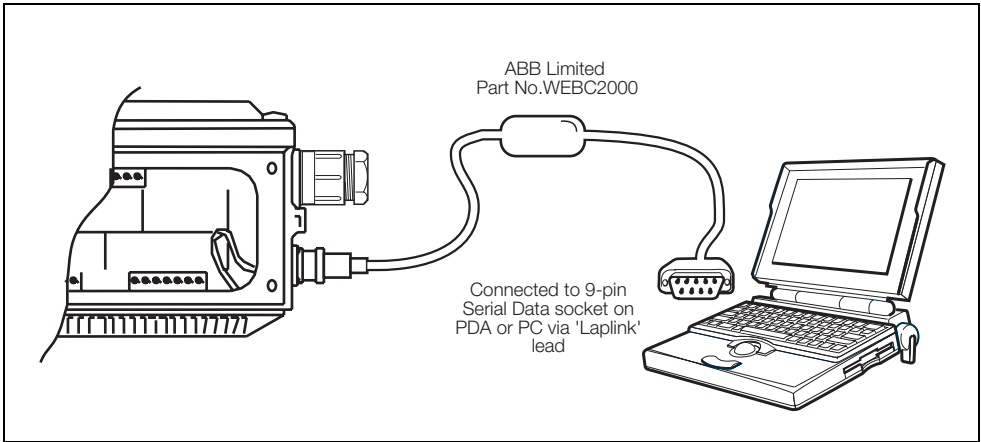

Fig. 3.10 Local Computer Connections

3.2.5 Remote Computer Connection (Option)

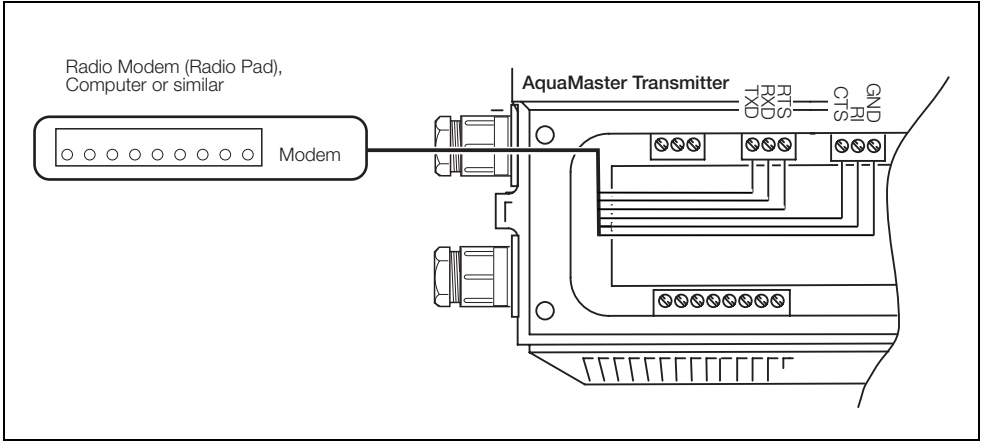

Fig. 3.11 RS232 Connections

AquaMaster Terminal	RS232	9-PIN PC Connector	25-PIN PC Connector
TXD	TXD	3	2
RXD	RXD	2	3
RTS	RTS	7	4
CTS	CTS	8	5
RI	RI	9	22
GND	GND	5	7

Table 3.2 RS232 Connections

### 3.2.6 Power Supply Connection Options

**Warning.**

- DISCONNECT THE SUPPLY FROM ANY CABLES BEING TERMINATED ON THE TRANSMITTER.
- Electrical installation and earthing (grounding) must be in accordance with relevant national and local standards.

**Note.** Power Supply connections/earthing arrangements are identical for Cathodically Protected systems.

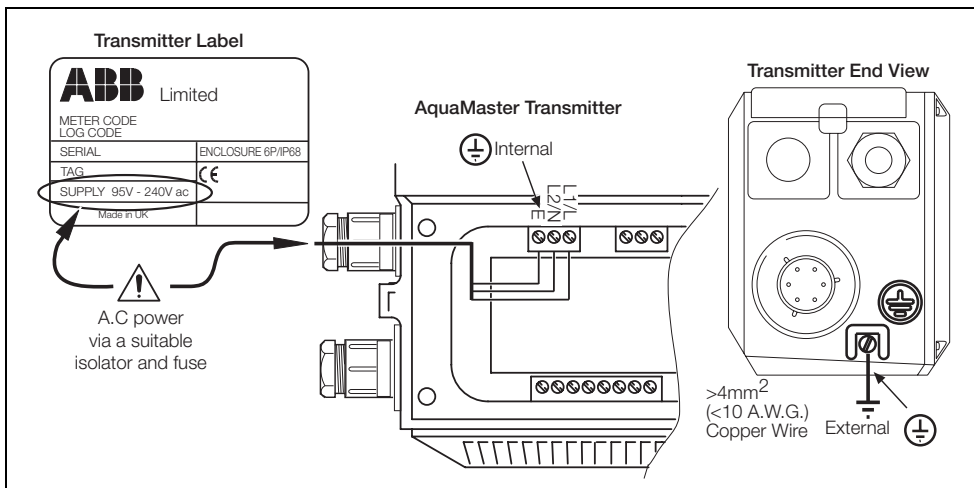

Fig. 3.12 Power Supply Connections (A.C. Version Transmitter)

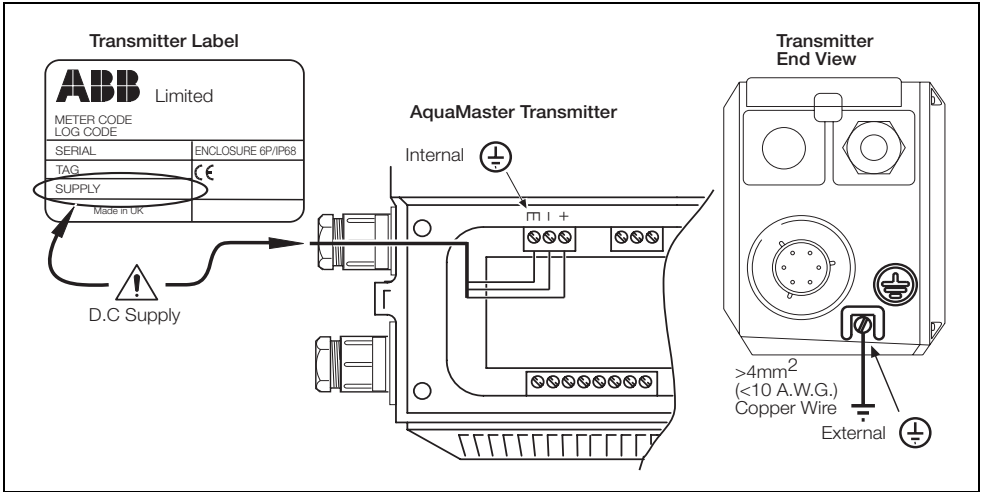

Fig. 3.13 Power Supply Connections (D.C. Version Transmitter)

### 3.2.7 Pressure Transducer (Optional)

Optional pressure transducer cables are available for a range of pressures and cable lengths.

**Caution.** Ensure that only the pressure transducer supplied with the transmitter is used. Use of other pressure transducers requires alteration of the pressure span and zero factors in the transmitter – see Quick Reference Programming guide.

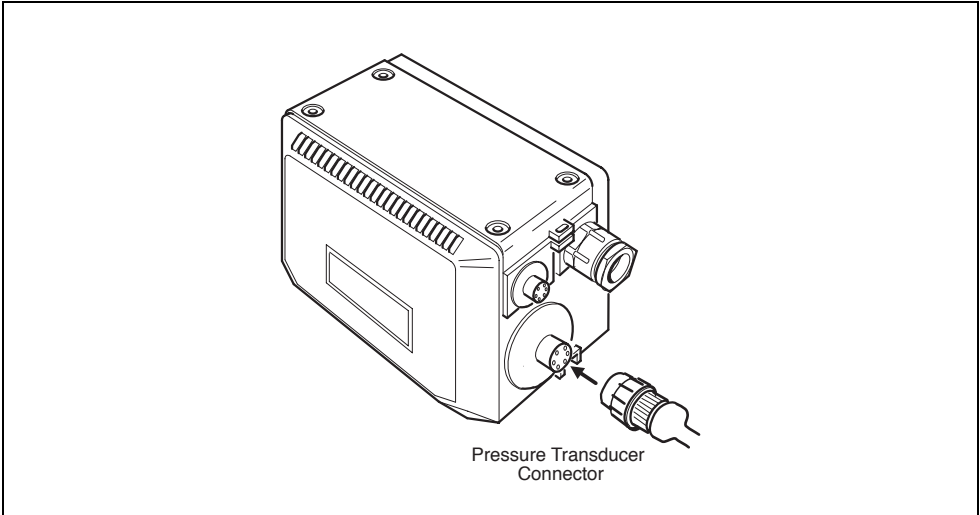

Fig. 3.14 AquaMaster Transmitter fitted with Optional Pressure Transducer Connector

### 3.2.8 Environmental Protection (Option)

**Warning.**

- Potting materials are toxic – use suitable safety precautions.
- Read the manufacturers instructions carefully before preparing the potting material.

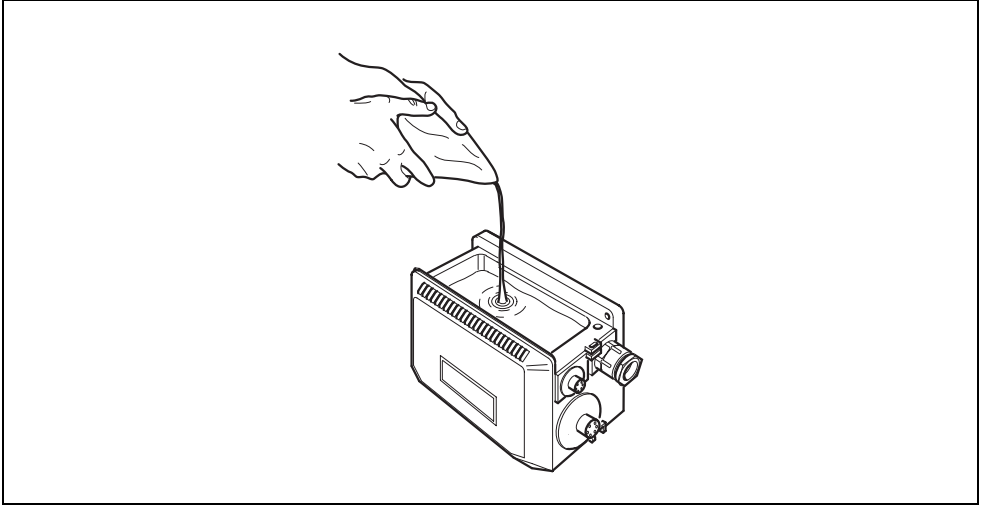

Fig. 3.15 Potting the Transmitter

**Caution.**

- For increased protection against accidental water ingress, for example by poor gland tightening, pot the termination area.
- Check all connections and operations before potting – see section 3, page 17.
- Do not overfill or allow the potting material to come into contact with 'O' rings or grooves.
- Do not let potting material enter conduit, if used.

## 4 Setting Up

### 4.1 Introduction

The basic equation for volume measurement using AquaProbe is:

$$Q = A F_i F_p V$$

Where: Q = flow rate,  
 F<sub>i</sub> = insertion factor  
 F<sub>p</sub> = profile factor  
 V = velocity  
 A = area

The pipe diameter, profile factor and insertion factor must be determined as detailed in see section 5.2, page 32 to 5.3, as applicable.

**Note.** Due to software configuration, all calculations are in metric units. Therefore if using an imperial pipe, the diameter **MUST** be converted into millimetres (1in = 25.4mm) i.e. a 36in pipe = 914mm

### 4.2 Centre Line Method

1. Determine the internal diameter D of the pipe, in millimetres, by the most accurate method available.
2. Determine the profile factor F<sub>p</sub> from Fig. 4.1.
3. Calculate the insertion factor

$$F_i = \frac{1}{1 - (38/\pi D)}$$

**Example** – for a pipe of internal diameter 593mm (23.35in):

F<sub>p</sub> = 0.861 (derived from Fig. 4.1)

$$F_i = \frac{1}{1 - (38/593\pi)}$$

F<sub>i</sub> = 1.021

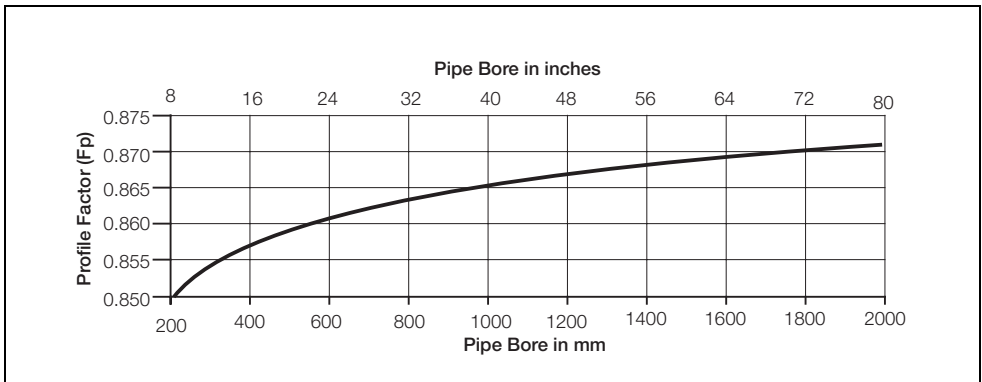

Fig. 4.1 Profile Factor vs Velocity for Pipe Sizes 200 to 2000mm (8in to 80in)



### 4.3 Mean Axial Velocity Method (1/8 Diameter)

1. Determine the internal diameter D of the pipe, in millimetres, by the most accurate method available.
2. A profile factor  $F_p$  of 1 must be used.
3. Calculate the insertion factor

$$F_i = \left[ 1 + \frac{12.09}{D} + \frac{1.3042}{\sqrt{D}} \right]$$

**Example** – for a pipe of internal diameter 593mm (23.35in):

$$F_p = 1$$

$$F_i = \left[ 1 + \frac{12.09}{593} + \frac{1.3042}{\sqrt{593}} \right]$$

$$F_i = 1.074$$

### 4.4 Partial Velocity Traverse

Refer to the Appendix A1 for procedure.

### 4.5 AquaProbe Transmitter Setup

The AquaProbe Transmitter can be set up to display point velocity, mean velocity or flow rate, as required. For full programming details refer to the AquaProbe Quick Reference Guide.

## 5 Start Up And Operation

### Warning.

- The lithium battery used in this device may present a risk of fire or chemical burn if mistreated. Do not recharge, disassemble, heat above 100°C or incinerate.
- Replace battery with ABB Limited Part No. WABC2001 only. Use of another battery may present a risk of fire or explosion.
- Dispose of used battery promptly. Keep away from children.
- Dispose of used batteries in accordance with your local regulations.
- Where possible, recycle used batteries.
- Contact your local environmental authority for further information regarding disposal or recycling schemes for used batteries.

### Note.

- If fitting a battery on an external powered (a.c. or d.c.) unit, ensure the unit is powered during this operation.
- Each battery must be connected to the cable from the same side of the termination area as the battery position in the lid.

### 5.1 Fitting the Battery

If the AquaMaster has been supplied with one or two batteries, but not connected, then proceed as follows:

1. Remove the top cover of the transmitter – see section 3.1.3, page 19.
2. Invert the cover.
3. Slide out the connector from behind the battery retaining clamp.
4. Connect the battery or batteries to the wire connector(s) inside the top of the transmitter unit; left hand battery to left hand connector and right hand battery to right hand connector.
5. Ensure that the end of the battery with the connection wires is pushed up against the inside end of the top cover.
6. Push the connection centrally behind the battery retaining clamp to secure the battery.
7. Fit the top cover to the transmitter and ensure the screws are tightened fully.

### 5.2 Start-up

If the AquaMaster is received with a protective plastic film over the display window, remove this film before commencing normal operation.

When the power is connected or the plastic film is removed, the AquaMaster performs a self test operation, and indicates a successful completion with 'EE Pass' displayed.

If the display shows 'EE Fail 1', remove all power, check the sensor wiring and apply power.

If the display shows 'EE Fail 2 or 3', contact ABB.

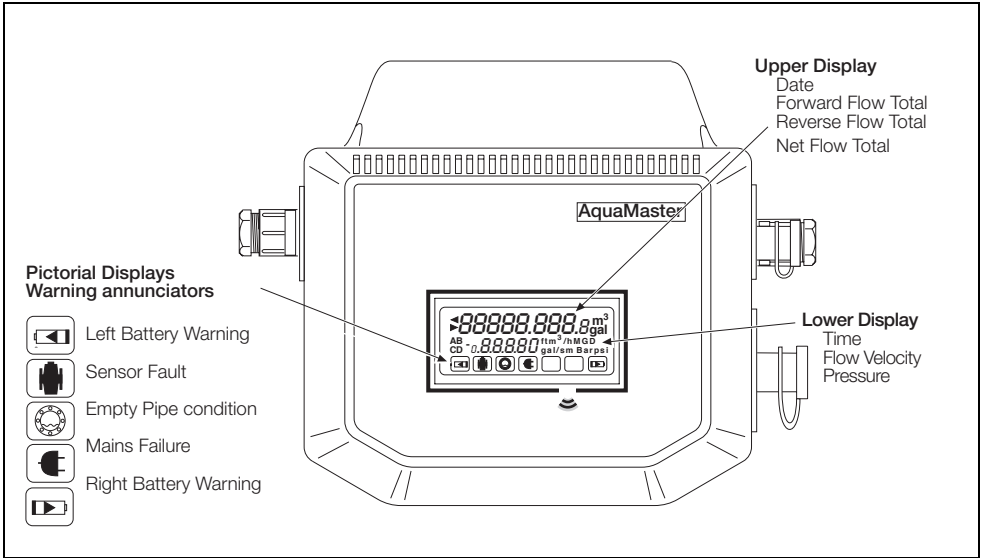

Fig. 5.1 Location of Controls

### 5.3 Display Activation

For normal operation, activate the light sensitive display by first covering the display area totally. On removing the covering, the display activates and cycles through the programmed set of display measurements.

With external power applied, the display is permanently activated.

To alter the displayed set of measurements, or instrument setup, see the Quick Reference Programming Guide.

**Note.** For the use of local or remote serial communication, and configuration, see the Quick Reference Programming Guide.

## 5.4 Replacing the Battery

**Caution.** If replacing the battery on an external powered (a.c. or d.c.) unit, ensure it is powered during this operation. For dual battery units, replace only the battery above the indicated battery legend.

**Note.** Each battery must be connected to the cable from the same side of the termination area as the battery position in the lid.

### Normal Operation

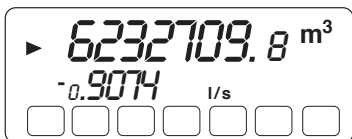

If both batteries are good, then no battery alarm is indicated.

### Replace Battery

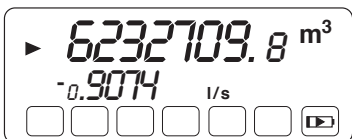

When a battery alarm is shown, replace the cell on the side indicated. (In this example, the Right Battery).

### Replace both batteries

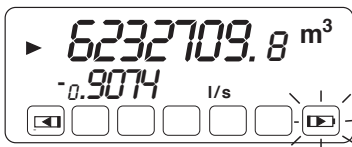

If both batteries require replacement, it is important to first change the cell indicated by the steady icon.

The flashing icon indicates the battery currently in use.

### Proceed as follows:

1. Remove the top cover of the transmitter – see section 3.1.3, page 19.
2. Invert the cover.
3. Slide out the connector from behind the battery retaining clamp and pull the connector apart.
4. Remove the battery.
5. Fit a new battery (ABB Limited Part No. WABC2001) ensuring that the end of the battery with the connection wires is pushed up against the inside end of the top cover.
6. Connect the battery connector to the connector previously removed.
7. Push the connection centrally behind the battery retaining clamp to secure the battery.
8. Fit the top cover to the transmitter and ensure the screws are tightened fully.

## Appendix A

### A.1 Testing the Flow Profile for Symmetry

If there is any doubt as to the symmetry of the flow profile (see section 2.2, page 6), a Partial Velocity Traverse should be carried out. This procedure involves comparing the value of velocity at two points at equal distances from the centre line.

It is normal to compare the flow velocities at insertion depths of 1/8 and 7/8 of the pipe diameter as these points are always on the 'knee' of the profile.

#### A.1.1 Partial Velocity Traverse

Determine the internal diameter D of the pipe, in millimetres, by the most accurate method available. If the AquaProbe insertion length is greater than the internal diameter of the pipe, proceed with the Single Entry Point Method detailed in Section A.1.2. If the AquaProbe insertion length is less than the internal diameter of the pipe, proceed with the Dual Entry Point Method detailed in Section A.1.3.

#### A.1.2 Single Entry Point Method

1. Insert the probe to a depth of 1/8 the pipe diameter – see Fig. 2.14.

**Note.** Due to software configuration, all calculations are in metric units. Therefore if using an imperial pipe, the diameter **MUST** be converted into millimetres (1 in = 25.4mm) i.e. a 36in pipe = 914mm.

2. Calculate the insertion factor

$$F_i = \left[ 1 + \frac{12.09}{D} + \frac{1.3042}{\sqrt{D}} \right]$$

3. Refer to the AquaProbe Transmitter Configuration Manual and enter a Blockage Factor (BL) of value equal to  $F_i$ .
4. Record the flow velocity reading.
5. Insert the probe to a depth of 7/8 the pipe diameter.

6. Calculate the insertion factor

$$F_i = \left[ 1 + \frac{12.09}{D} + \frac{1.3042}{\sqrt{D}} \right]$$

7. Refer to the AquaProbe Transmitter Configuration Manual and enter a Blockage Factor (BL) of value equal to  $F_i$ .
8. Record the flow velocity reading.
9. Calculate the ratio of the two values recorded.

If the ratio is between 0.95 and 1.05 the flow profile is acceptable and the procedure detailed in section 4.2 can be used. If outside this ratio the AquaProbe should be resited for optimum accuracy.

### A.1.3 Dual Entry Point Method

Refer to Section 2.5 and fit a second mounting boss directly opposite the one already fitted.

**Note.** Due to software configuration, all calculations are in metric units. Therefore if using an imperial pipe, the diameter **MUST** be converted into millimetres (1in = 25.4mm) i.e. a 36in pipe = 914mm.

1. Insert the probe to a depth of 1/8 the pipe diameter through the original mounting boss.
2. Calculate the insertion factor
$$F_i = \left[ 1 + \frac{12.09}{D} + \frac{1.3042}{\sqrt{D}} \right]$$
3. Refer to the AquaProbe Transmitter Configuration Manual and enter a Blockage Factor (BL) of value equal to  $F_i$ .
4. Record the flow velocity reading.
5. Insert the probe to a depth of 1/8 the pipe diameter through the second mounting boss.
6. Record the flow velocity reading.
7. Calculate the ratio of the two values recorded.

If the ratio is between 0.95 and 1.05 the flow profile is acceptable and the procedure detailed in Section 4.2 can be used. If outside this ratio the AquaProbe should be resited for optimum accuracy.

# Appendix B Aquamaster Block Diagram

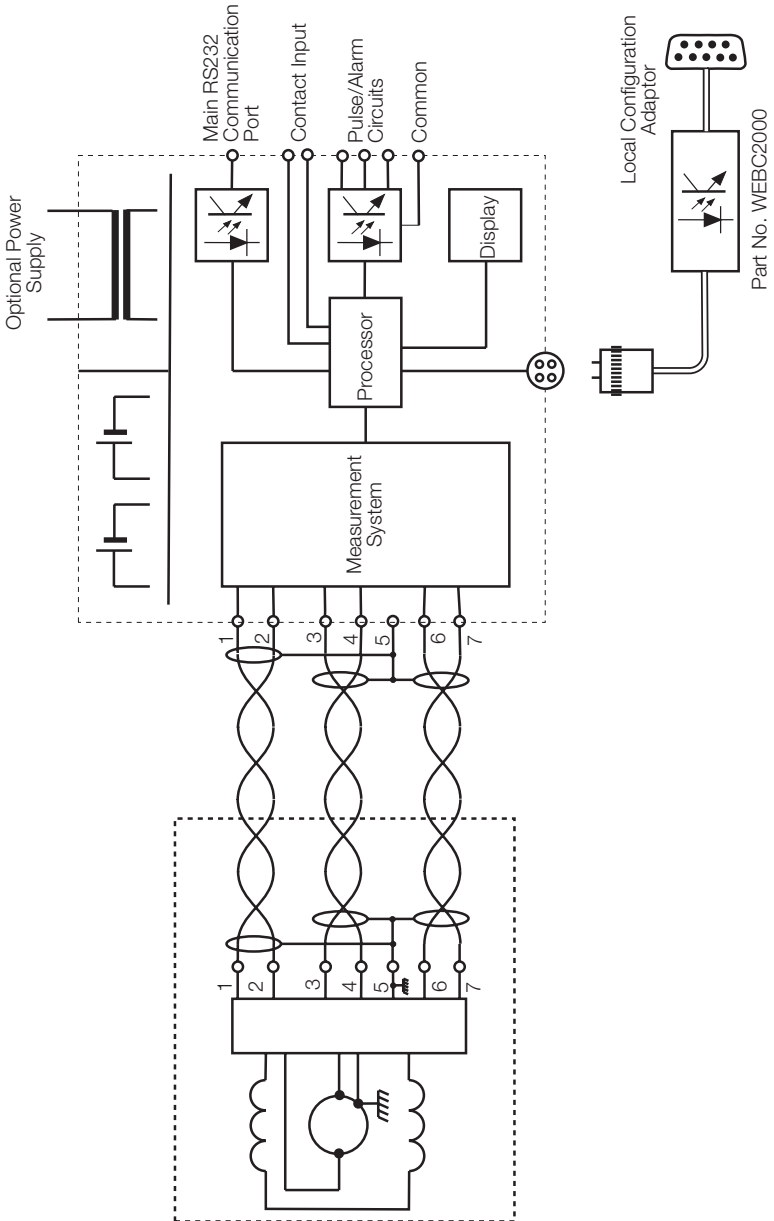

## Notes







# PRODUCTS & CUSTOMER SUPPORT

## Products

### Automation Systems

- for the following industries:
  - Chemical & Pharmaceutical
  - Food & Beverage
  - Manufacturing
  - Metals and Minerals
  - Oil, Gas & Petrochemical
  - Pulp and Paper

### Drives and Motors

- AC and DC Drives, AC and DC Machines, AC Motors to 1kV
- Drive Systems
- Force Measurement
- Servo Drives

### Controllers & Recorders

- Single and Multi-loop Controllers
- Circular Chart and Strip Chart Recorders
- Paperless Recorders
- Process Indicators

### Flexible Automation

- Industrial Robots and Robot Systems

### Flow Measurement

- Electromagnetic Flowmeters
- Mass Flowmeters
- Turbine Flowmeters
- Wedge Flow Elements

### Marine Systems & Turbochargers

- Electrical Systems
- Marine Equipment
- Offshore Retrofit and Refurbishment

### Process Analytics

- Process Gas Analysis
- Systems Integration

### Transmitters

- Pressure
- Temperature
- Level
- Interface Modules

### Valves, Actuators and Positioners

- Control Valves
- Actuators
- Positioners

### Water, Gas & Industrial Analytics

#### Instrumentation

- pH, Conductivity and Dissolved Oxygen Transmitters and Sensors
- Ammonia, Nitrate, Phosphate, Silica, Sodium, Chloride, Fluoride, Dissolved Oxygen and Hydrazine Analyzers
- Zirconia Oxygen Analyzers, Katharometers, Hydrogen Purity and Purge-gas Monitors, Thermal Conductivity

## Customer Support

We provide a comprehensive after sales service via a Worldwide Service Organization. Contact one of the following offices for details on your nearest Service and Repair Centre.

### United Kingdom

ABB Limited  
Tel: +44 (0)1453 826661  
Fax: +44 (0)1453 829671

### United States of America

ABB Inc.  
Tel: +1 215 674 6000  
Fax: +1 215 674 7183

#### Client Warranty

Prior to installation, the equipment referred to in this manual must be stored in a clean, dry environment, in accordance with the Company's published specification.

Periodic checks must be made on the equipment's condition. In the event of a failure under warranty, the following documentation must be provided as substantiation:

1. A listing evidencing process operation and alarm logs at time of failure.
2. Copies of all storage, installation, operating and maintenance records relating to the alleged faulty unit.

---

**ABB** has Sales & Customer Support expertise  
in over 100 countries worldwide

**[www.abb.com](http://www.abb.com)**

The Company's policy is one of continuous product  
improvement and the right is reserved to modify the  
information contained herein without notice.

Printed in UK (04.07)

© ABB 2007



**ABB Limited**  
Oldends Lane, Stonehouse  
Gloucestershire  
GL10 3TA  
UK  
Tel: +44 (0)1453 826661  
Fax: +44 (0)1453 829671

**ABB Inc.**  
125 E. County Line Road  
Warminster  
PA 18974  
USA  
Tel:+1 215 674 6000  
Fax:+1 215 674 7183