

White paper - "Preliminary"

# Emax 2, all-in-one innovation Load Shedding



# Emax 2

## Load Shedding innovation

### Index

<b>Introduction</b> .....	2
<b>Emax 2, all-in-one innovation</b> .....	3
<b>Benefits</b> .....	4
Service continuity .....	4
Space saving .....	6
Ease of use .....	8
<b>How it works</b> .....	9
Basic Load Shedding .....	10
Operating principle .....	11
Adaptive Load Shedding .....	12
Operating principle .....	12
<b>Ekip Connect 3.0 commissioning tool</b> .....	14
<b>Application example of Adaptive Load Shedding</b> .....	20
Industry .....	20
Building .....	22
<b>Electrical diagrams</b> .....	24
<b>Shopping List</b> .....	28

# Emax 2

## Load Shedding innovation

### Introduction

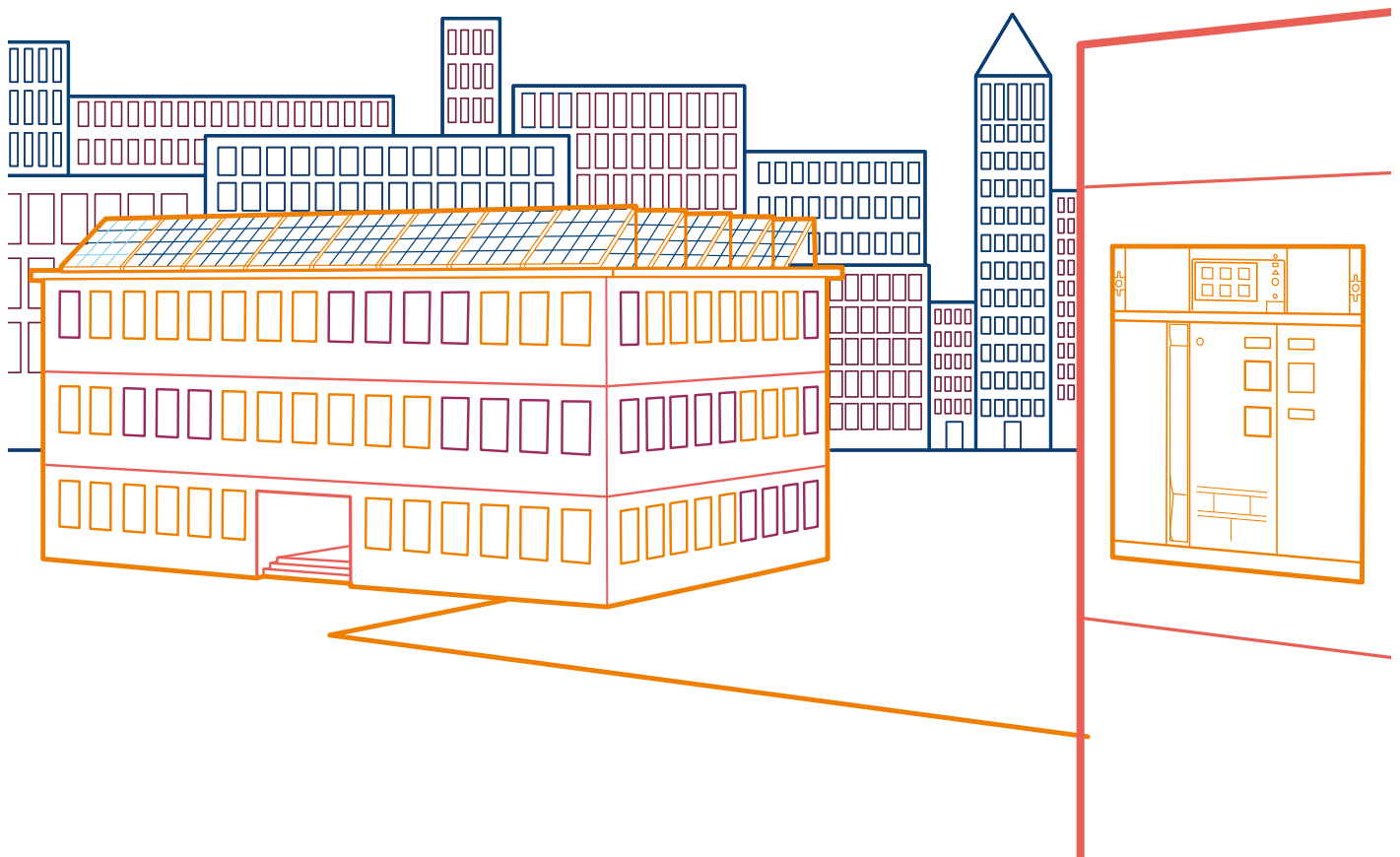
Power supply reliability is one of the main topic in all the market segments. Not only critical facilities like hospitals, banks or data centers, but also ships, remote communities and industries are very sensitive to service continuity, since even one blackout means a long non-productive time (NPT) with a consequent waste of productivity in their processes. Some cases are due to weak grids that are not able to satisfy 24/7/365 continuous operation for overload or fault reasons. Other critical conditions are related to environmental contingencies, like hurricane events or earthquakes that increase enormously the number of power outages.

Grid resiliency is the answer to this request in terms of electrical distribution reinforcement and generation safeguard. This means huge investments for utilities and heavy modification of plant design for facility owners to get more reliability.

Microgrids are the next level approach in low voltage meshed networks which fully meet these expectations, using their capability to define power absorption and to move from grid-connected to islanded operation mode quickly and without stress. On one hand, the power demand definition is able to avoid overwork situations that can compromise the electrical stability. On the other hand, the bumpless transition gives the chance for the plant to remain power supplied even off-grid, when the main grid is down.

Microgrids are the tangible result of the grid evolution, adding automation pillar in the energy distribution. This new network paradigm cuts the investments necessary to improve the grid stability, ensuring savings for both utilities and end users. Based on this speed-up concept, the low voltage distribution is continuously hunting for flexible solutions, able to reduce space in the switchgear for panel builders and simply upgrade old plants using advanced solutions, which do not require a high engineering and customization effort for consultants and system integrators. The electronic intelligence can now face all the challenges enabling software solutions to be protagonist of the Microgrid control, giving flexibility for O&Ms manufacturer.

The circuit breaker becomes smart and able to protect the Microgrids under every conditions, ensuring service continuity, space savings and ease of use.



## Emax 2, all-in-one innovation

ABB Emax 2, the all-in-one smart circuit breaker, integrates innovative algorithms to safeguard the Microgrids and manage their resources maximizing the efficiency. It embeds patented functions based on load shedding which reduces the Microgrid stress in all situations.

Emax 2 is the main circuit breaker of the low voltage Microgrid located at the interface point with the medium voltage grid, able to control the plant in every circumstances.

### 1) Microgrid in islanding operation

After the Emax 2 circuit breaker opening, because of interface protection systems intervention or external command, the Microgrid should transit from on-grid to off-grid state with bumpless transition. When it is standalone, the power absorption from the main grid ceases, so that the Microgrid loads remains supplied by the local generation, like diesel GenSet or energy storage systems. This Microgrid generation can be always active or started up by an automatic transfer switching (ATS) logic after the disconnection from the main grid, depending on the plant configuration. During the islanding transition, it is very important to avoid the frequency drop, otherwise the generation protections could trip jeopardizing the Microgrid stability with consequently a long downtime. Emax 2, employing the embedded voltage current and voltage measurements, integrates two different fast load shedding logics to reduce this blackout risk, protecting the Microgrid during the intentional or unintentional islanding operation:

- a) Basic Load Shedding, simple logic able to recognize the Microgrid disconnection event and shed a group of not priority loads thus ensuring a fast time response and power balance.
- b) Adaptive Load Shedding, the advanced algorithm available with Emax 2 as an enhancement of the basic version. The intelligent software embedded in the circuit breaker sheds very quickly the not priority loads according to the Microgrid power consumption and frequency measurements. Moreover, such software has a dedicated configuration for backup generation related to ATS and the software itself is even able to estimate the energy produced by a solar plant based on plant-geography settings.

### 2) Microgrid in grid-connected operation

During normal circumstances, the microgrid point is generally connected to the Utility in order to inject/adsorb the surplus or the lacking energy. During this situation, with Emax 2 as main circuit breaker installed immediately downstream the MV/LV transformer in closed status, power overload should be avoided not to stress too much the plant elements. In order to satisfy this, the circuit breaker embeds a patented load shedding algorithm:

- a) Predictive Load Shedding, slow disconnection of loads based on the limit of the average power flow towards the Microgrid according to the transformer size designed for the power peak profile.

All the versions are available on Emax 2 platform for both the Microgrid situations, sharing some information about the loads under control in the plant.

The scope of this White Paper is to explain how Emax 2 manages the Microgrid transition from on-grid to off-grid, based on fast load shedding logics. For Microgrid connected case, please refer to 1SDC007410G0202. In the Emax 2 commissioning SW - Ekip Connect 3.0 - there is a dedicated tool where it is possible to enable the Predictive Load Shedding thanks to the SW license available with this commercial code 1SDA082922R1.

# Emax 2

## Load Shedding innovation

### Benefits

#### Service continuity

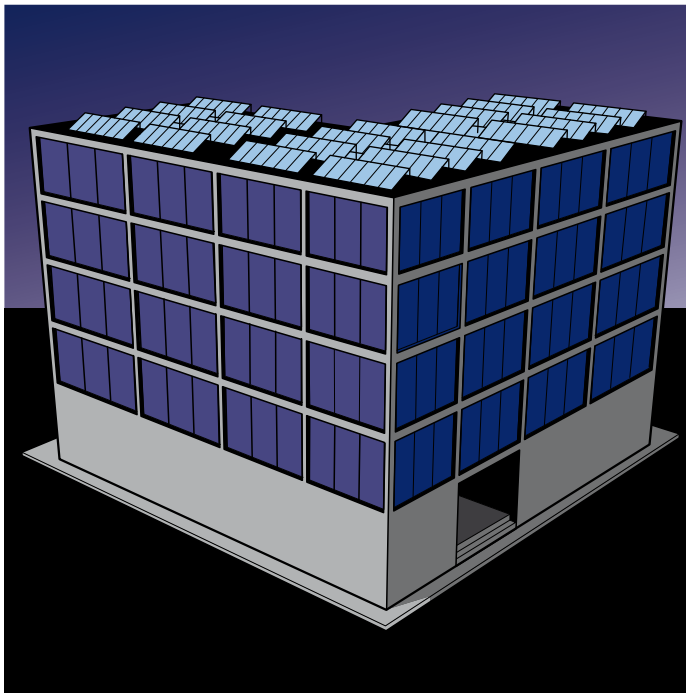
Emax 2 with load shedding features becomes the first circuit breaker that enables intentional or unintentional islanding and avoid consequent blackouts. Indeed, when a plant remain disconnected from the Utility grid, even if there is active local production, there is a significant stress that turns off all the generators with consequent blackout.

In any business, a lack of power supply always causes loss of money. For instance, on average, total annual downtime for automotive industry is 700h, which represents a cost avg of 1b USD (22kUSD per minute); for F&B industry is about 500h annually; for a data center the average cost of power outage is 8000 USD per minute, 600 KUSD per event; for a drill ship NPT means an average of \$12 million/year lost.

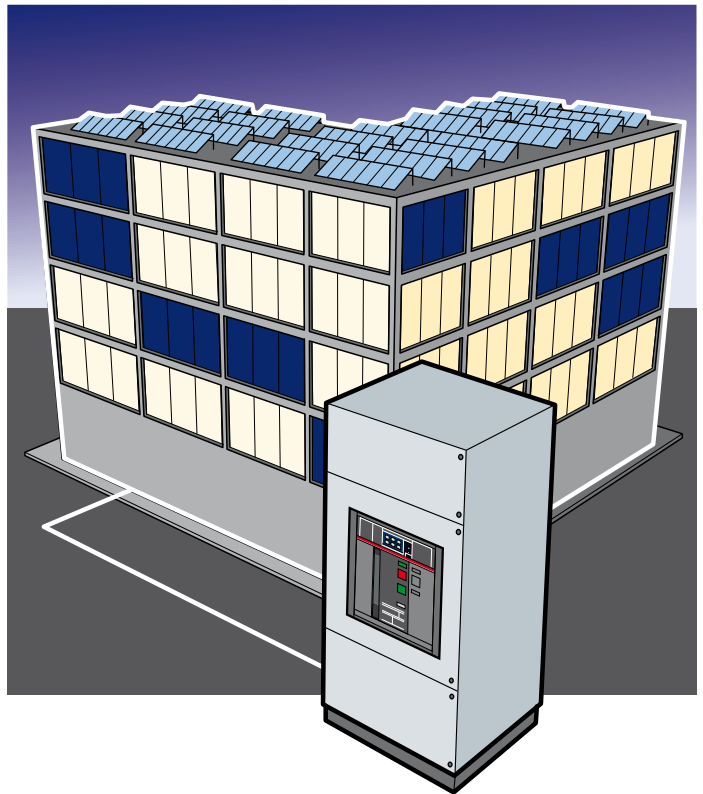
For all these reasons, it is very important to reduce the unplanned interruptions and speed up the recovery phase<sup>1</sup>. Thanks to its load shedding function, Emax 2 not only improves the service continuity but also enhances the lifetime of the spinning generators.

<sup>1</sup> See White Paper 1SDC007118G0201 – Synchro Reclosing.

**Figure 1: Microgrid hospital without Emax 2 Load Shedding function**

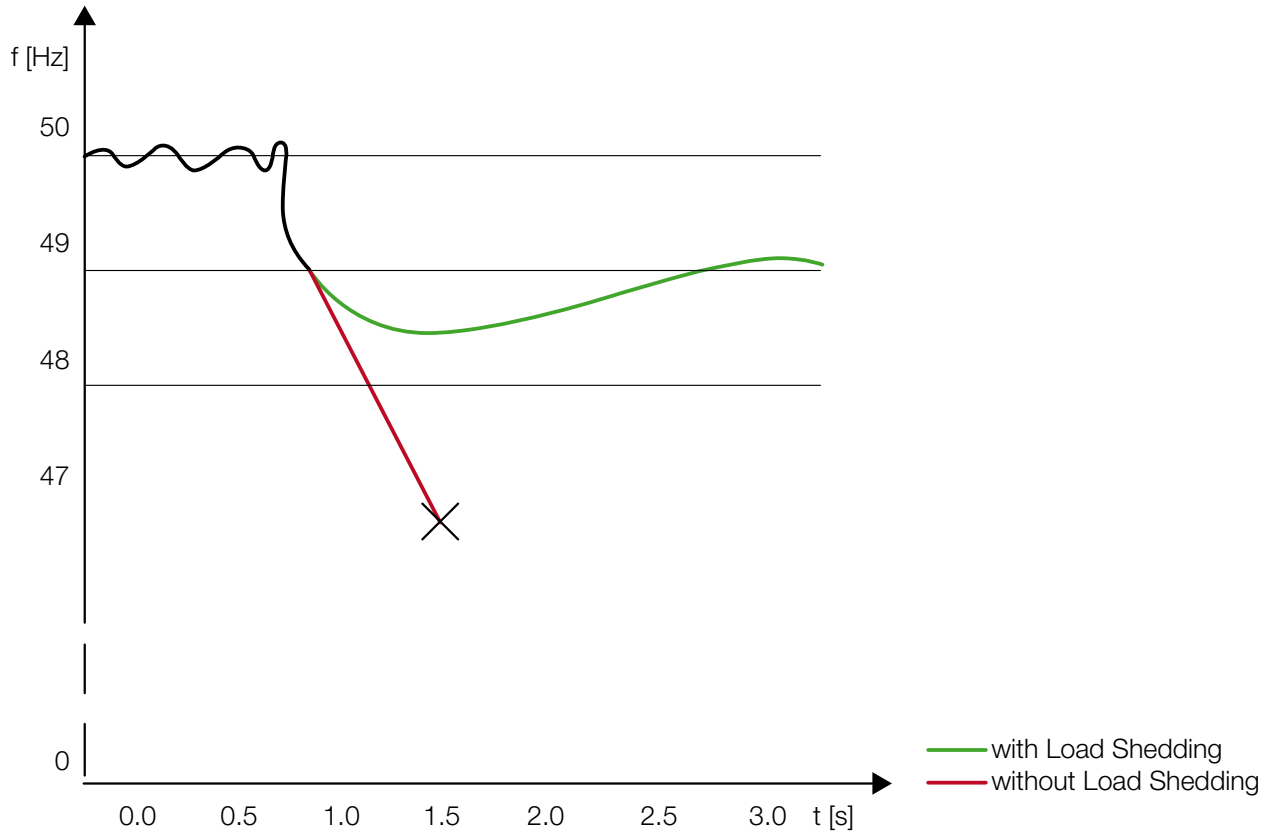


**Figure 2: Microgrid hospital with Emax 2 Load Shedding function**



In detail, the load shedding protects the Microgrid from a quick significant frequency drop, which disconnects the local generation as shown in Figure 3 for machine protection trips. The plant remains live and can work in a stand-alone state, with priority loads all time supplied and annual interruptions reduced.

Figure 3



# Emax 2

## Load Shedding innovation

### Space saving

Neither PLC neither external relays are needed as Emax 2 has embedded the intelligence to realize the load shedding logic, taking advantage of the internal current and voltage sensors for electrical parameter measurements.

In addition, static converters for low voltage photovoltaic production have typically anti-islanding protections: this implies another power deficit to be added to the main grid contribution lost during the Microgrid disconnection.

Emax 2 is the first circuit breaker that estimates solar production requiring very few input data to face also this power unbalance issue. Neither fieldbus network nor metering devices are needed for the function architecture, reducing components and mistakes in wiring installation.

Figure 4: load shedding layout without Emax 2

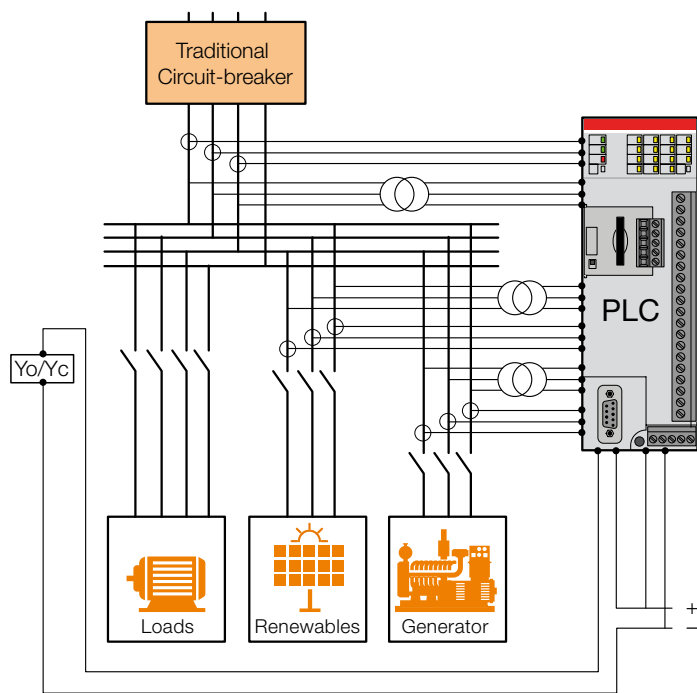
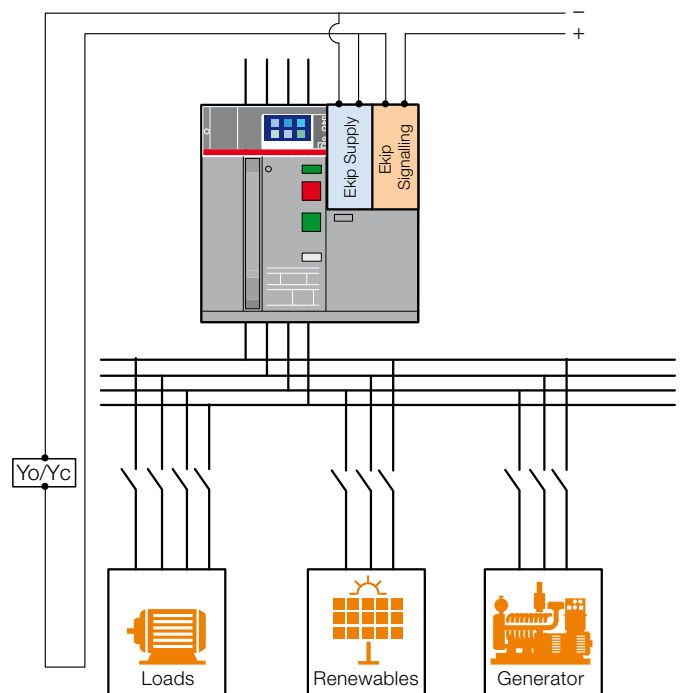


Figure 5: load shedding layout with Emax 2



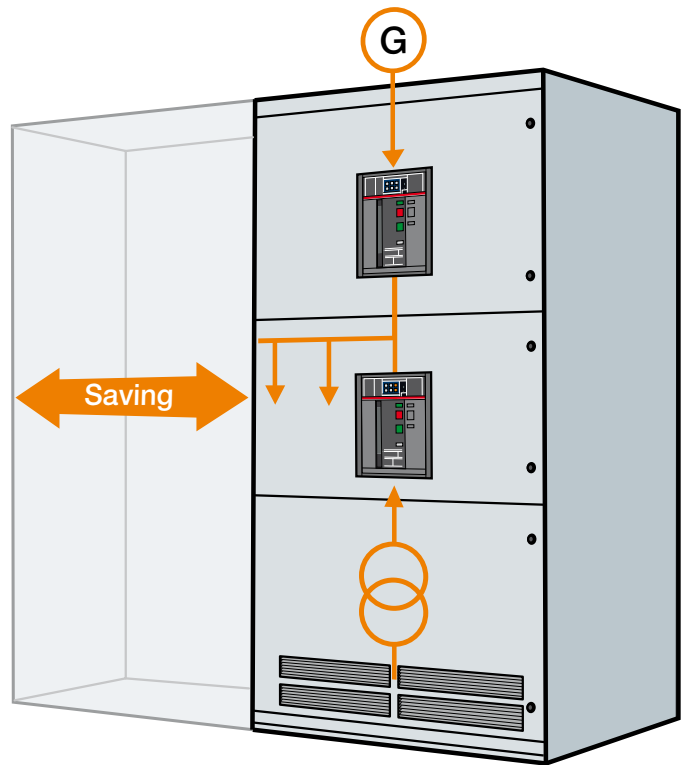
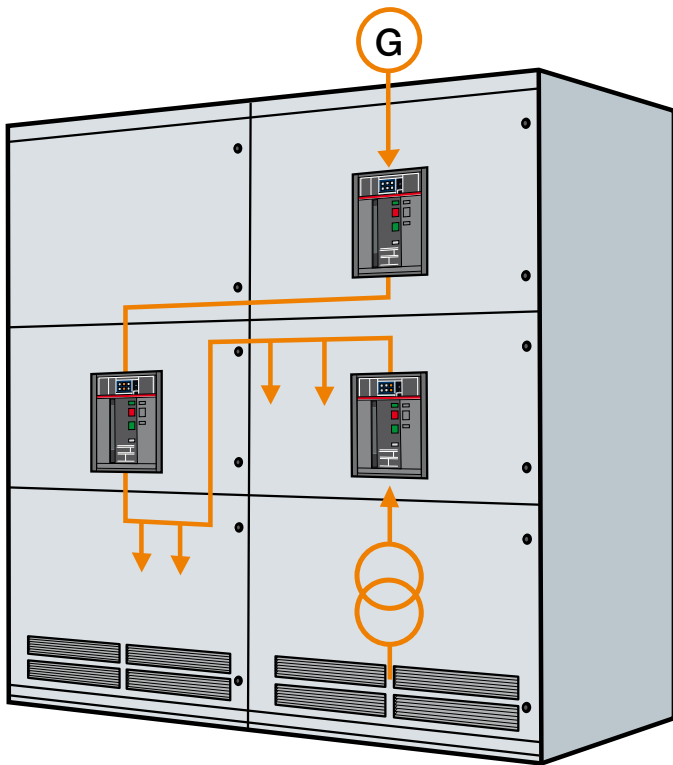
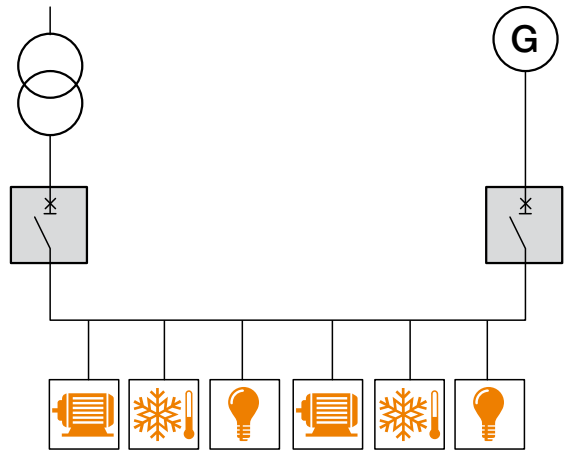
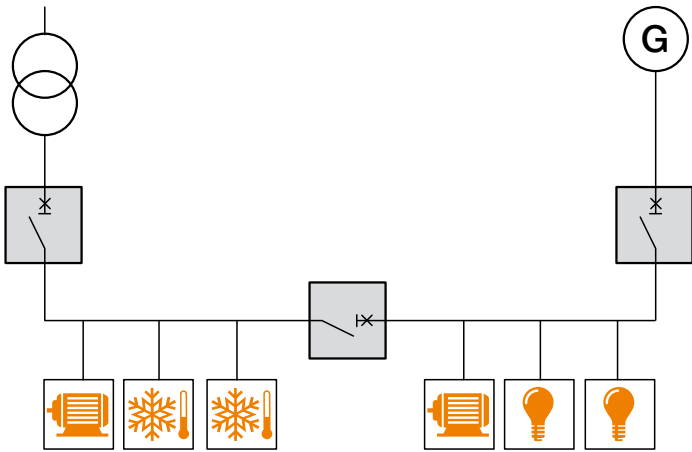
The load shedding algorithm embedded in Emax 2 is suitable with automatic transfer switch logics between switching devices. When the back-up generator is tailored to supply only priority loads, the ATS units are designed with three switching device configuration, like main – bus tie – gen. The bus tie switch disconnector distinguishes fundamental loads from the others, dividing the low voltage Microgrid busbar in two parts, adding a constraint in the plant design.

Thanks to load shedding inside Emax 2, where feasible, bus-tie switch disconnector is no longer required yet and this means less constraint for consultants and time for the electrical plant installation, besides a significant space saving up to 50% in the power distribution switchgear. ATS unit should manage only two sources, without interlock, logic programming and wiring connections for the third switch disconnector. In addition to this, using the Adaptive Load Shedding, the non-priority loads are not preset, but dynamically chosen in the right amount among a group of controllable ones, as the algorithm is self-tuned with the specific power unbalance identification.



Figure 6: electrical diagram and switchgear without load shedding embedded in Emax 2

Figure 7: electrical diagram and switchgear with load shedding embedded in Emax 2



# Emax 2

## Load Shedding innovation

### Ease of use

Load Shedding logics are generally set with high engineering skills and customization effort with devices as programmable logic controllers. Emax 2 ensures ease of use thanks to predefined templates and the user-friendly graphic interface in the SW commissioning tool. This reduces a lot the programming time, so as to speed up the Microgrid projects without this possible barrier.

Figure 8: load shedding commissioning without Emax 2

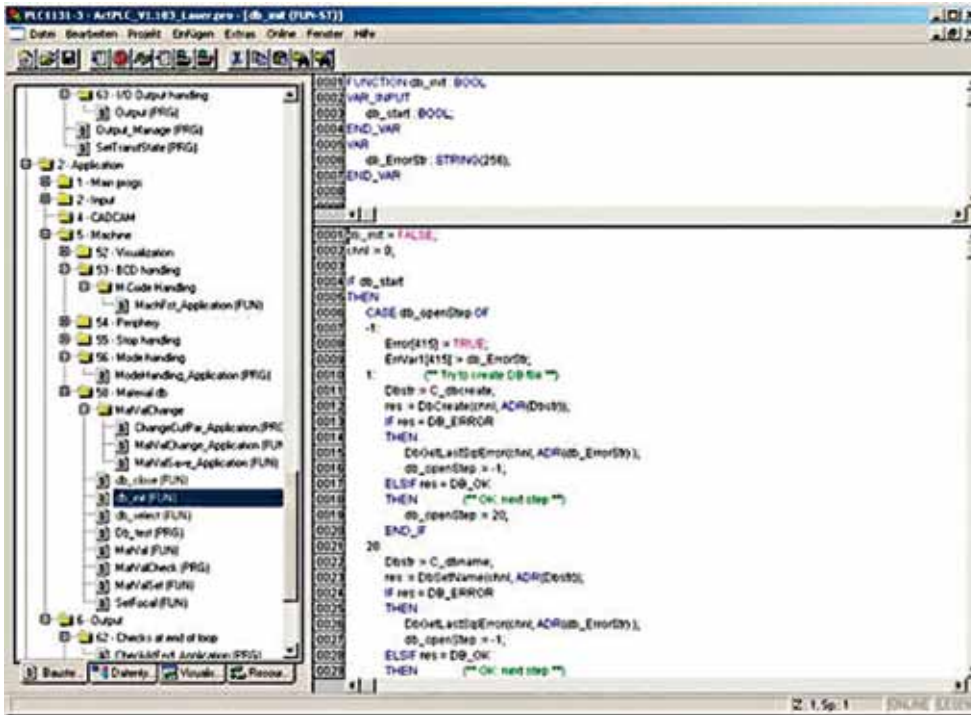
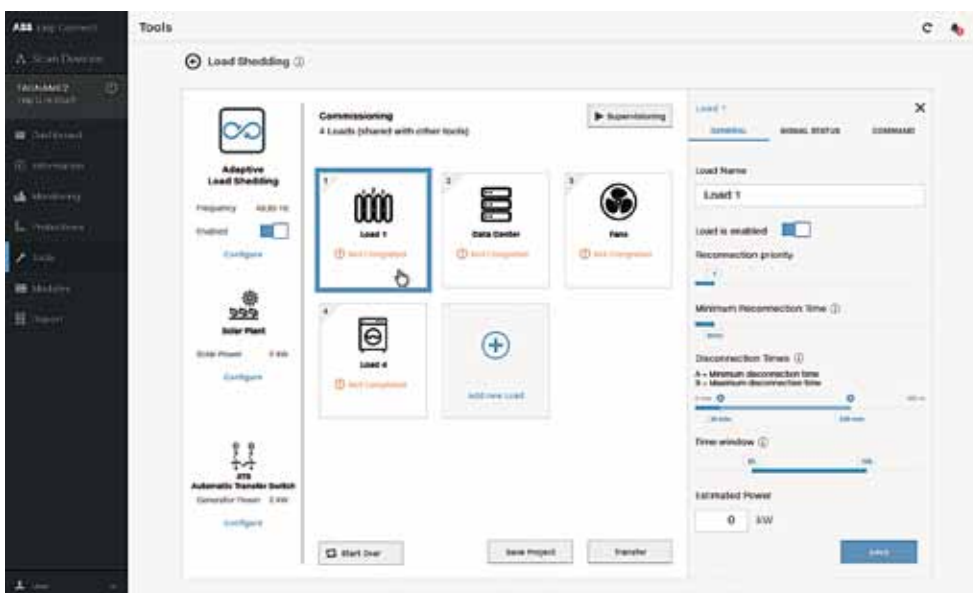


Figure 9: load shedding commissioning with Emax 2



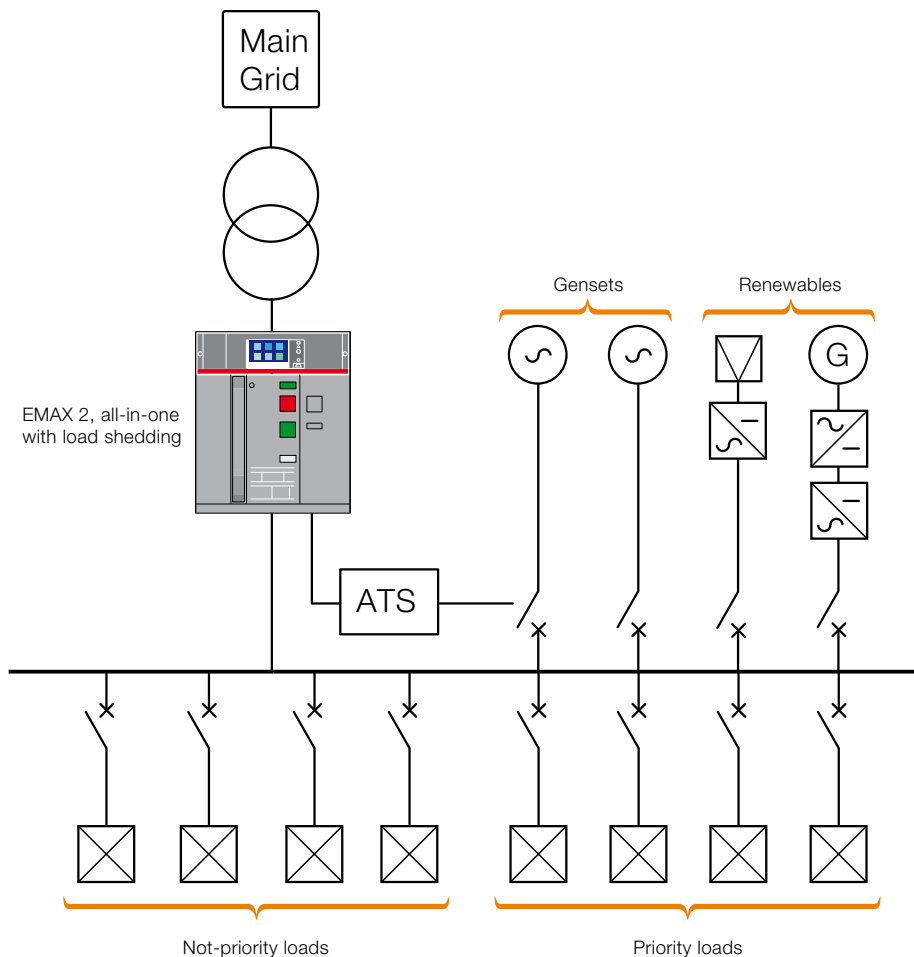
Besides, after the loads have been shed, no technician is needed to restore them, because Emax 2 automatically reconnects every load in a cyclical way, without risk of simultaneous start up. This feature guarantees reliability without waste of person-hours in facility management.

## How it works

Load Shedding functions are adopted to protect Microgrids during islanding operation. The application scenarios with just one smart circuit breaker are:

- Grid-connected plants with running GenSets, which contribute to the self-consumption together with potential renewable sources and support the load power supply in emergency conditions. It is the case of hybrid PV-diesel remote communities connected to weak distribution-grids where there are a lot of daily faults, or of facilities located in geographical areas where there are frequent environmental events, for example hurricanes or earthquakes.
- Grid-connected plants with back-up GenSets started up after main - gen transfer switching logics that require high reliability. For example, hospitals, banks or data centers need redundancy and continuous operation, so it is important to avoid blackouts when the emergency GenSets join the plant.

Figure 10: example of plant layout with Emax 2, Load Shedding



Even if Microgrids with diesel GenSets are the most common, they can be replaced with energy storage systems where the inertia of the plant remains guaranteed.

As an extension situation, also standalone Microgrids are suitable to adopt load shedding logics embedded in Emax 2, which becomes the main generator protection circuit breaker. In that scenario, like in marine applications, the generator is the main power source instead of the distribution-grid.

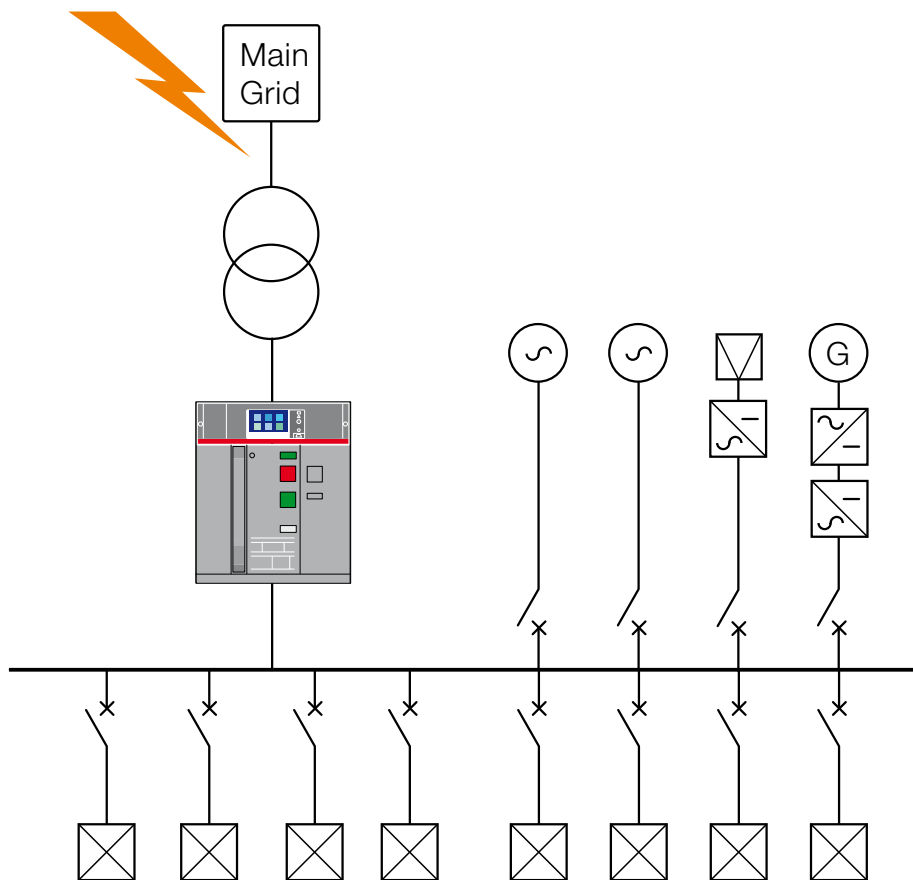
# Emax 2

## Load Shedding innovation

### Basic Load Shedding

Figure 11 shows the circuit breaker at the point of common coupling (PCC): when the circuit breaker opens, the Microgrid is disconnected. Because of this, an unwanted balance condition generally occurs, so Emax 2 realizes the load shedding of a group of non priority loads to restore power balance and, consequently, avoid a frequency reduction with the consequent downtime due to generator protection tripping. When the Microgrid reconnects to the medium voltage grid, Emax 2 returns in closed position, and the loads can be automatically closed again in a cyclical loop.

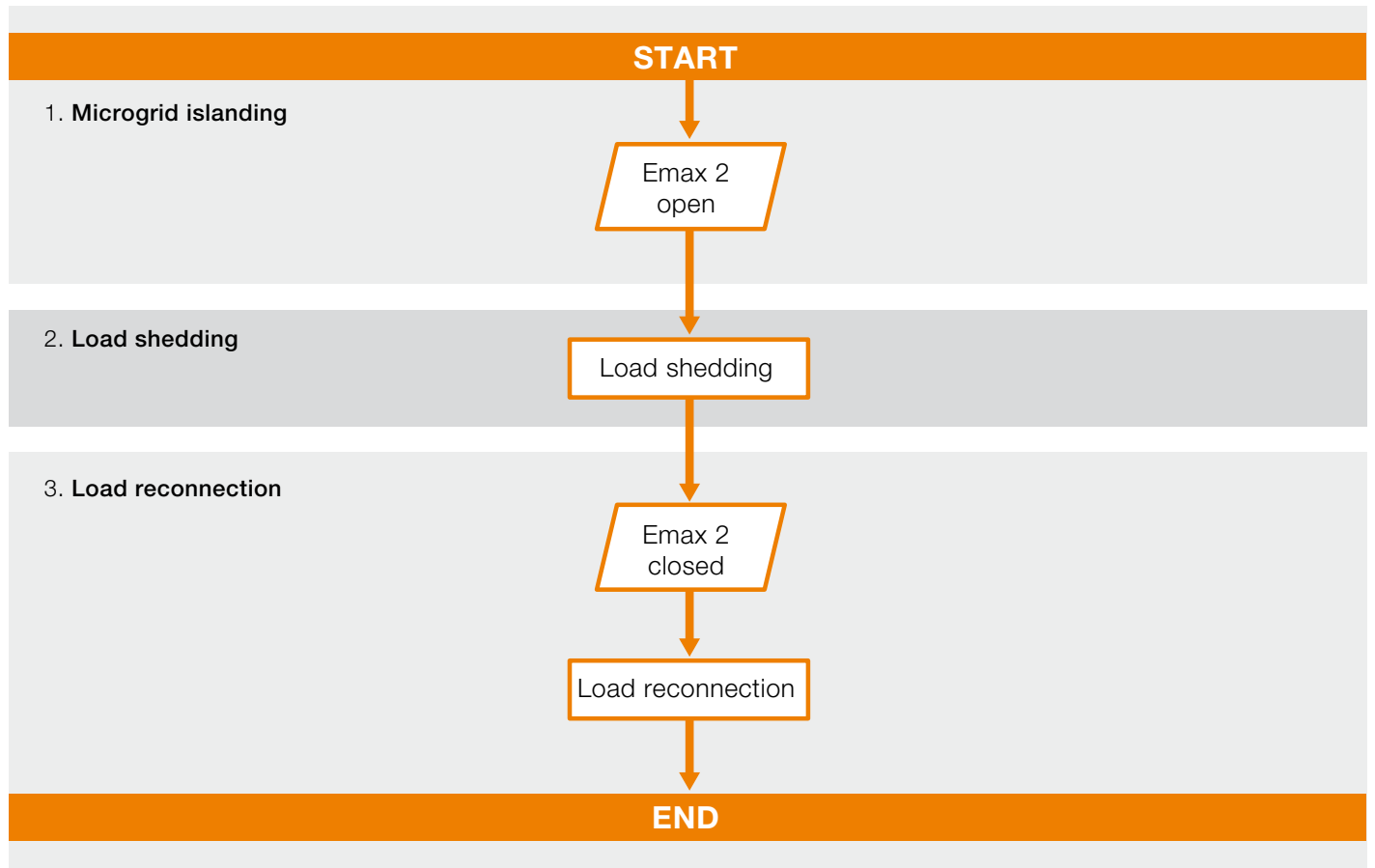
Figure 11: possible situation of fault that disconnects the Microgrid



### Operating principle

Figure 12 illustrates all the logic steps for Basic Load Shedding.

Figure 12: the logic steps for Basic Load Shedding



#### 1. Microgrid islanding

The main circuit breaker, Emax 2, opens for fault events or remote/manual operation, for example due to substation maintenance or Microgrid pricing strategy to enhance self consumption.

#### 2. Load Shedding

After the main circuit breaker opening, a group of N controlled load (maximum 15 loads) are simultaneously open by the same I/O contact. An alert output contact signals if the status of the load devices is not coherent with the commands sent.

#### 3. Load reconnecting

After the Microgrid reconnection to the main grid, it is recommended to automatic reclose the loads shed for network stabilization. This is realized only for the loads open without release tripped signal. Each n-load will be gradually reconnected in order to avoid a stressing transient using I/O contacts and closing commands. A time delay is defined for the reconnecting loop.

# Emax 2

## Load Shedding innovation

### Adaptive Load Shedding

The scenario is the same described for Basic Load Shedding, but Adaptive Load Shedding is a more sophisticated algorithm that sheds loads according to power flow evaluation. The circuit breaker understands which is the reason for the plant islanding, recognizes the emergency condition with advanced measurements and quickly acts load disconnection. In addition, it memorizes Microgrid instantaneous power absorption, parametrically characterizes load consumptions and estimates real-time solar production.

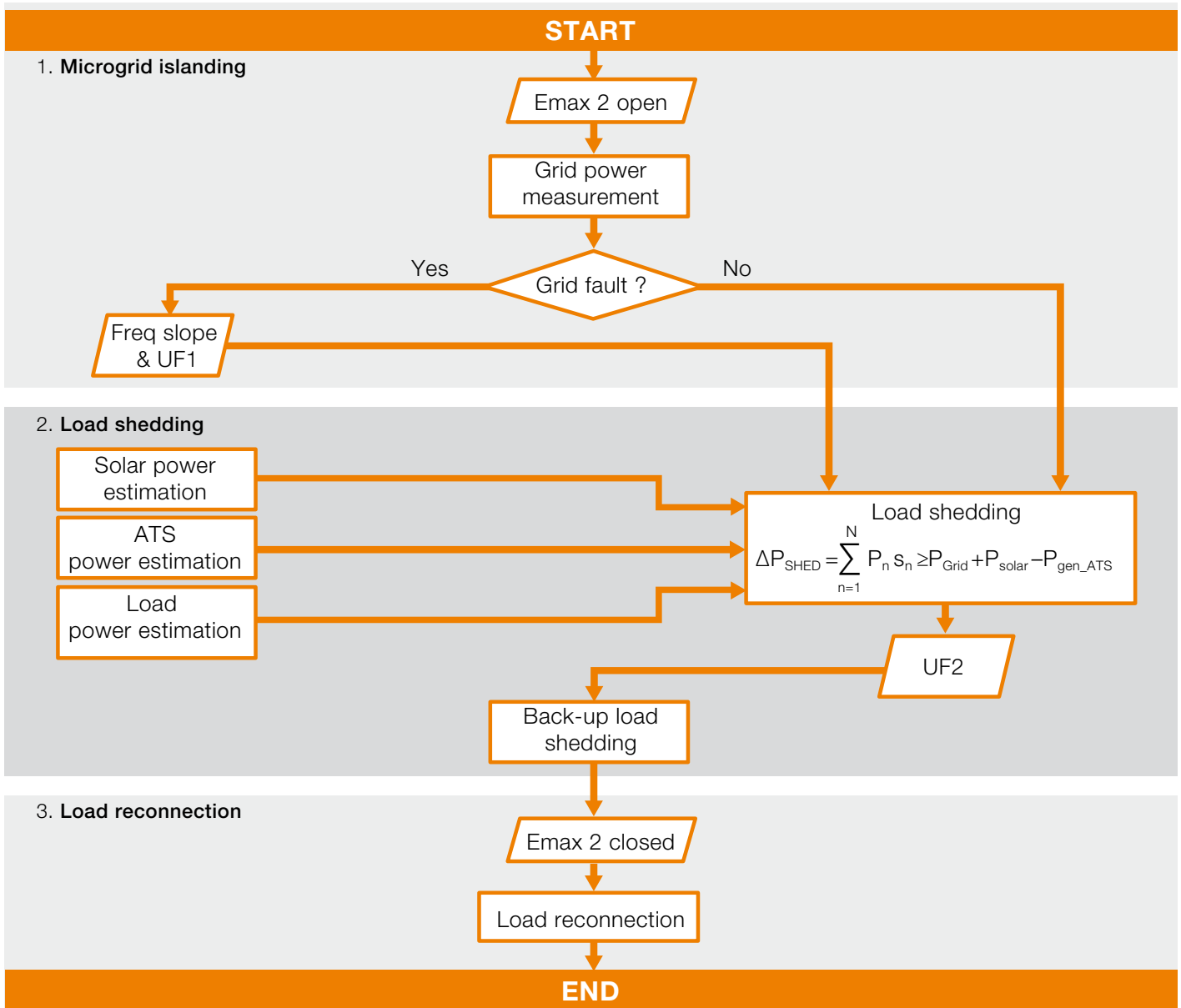
All these calculations make the load shedding tuned to each specific case. As in Basic Load Shedding, when the Microgrid returns to on-grid operation, the loads are automatically reconnected.

Besides, ATS logics are completely suitable with Adaptive Load Shedding. The back-up generator is connected to the grid according to transfer switching logics, so this amount of power, indicated by the user, is not considered in the analysis of not priority loads to be shed. This capability avoids the bus-tie switch disconnector installation, if used to separate non priority loads from priority ones.

### Operating principle

Figure 13 shows the main steps for the Adaptive Load Shedding algorithm built-in Emax 2 trip unit.

Figure 13: Adaptive Load Shedding logics



## 1. Microgrid islanding

The islanding operation starts on the main circuit breaker - Emax 2 opening event. The circuit breaker bi-directionally measures the power flow of the Microgrid and identifies if the plant is consuming more than producing or vice-versa before the opening. In the first case, load shedding sequence evaluation is initiated.

Emax 2 understands if the opening has been due to fault events in the main grid or to other reasons, like maintenance, inter-tripping with medium voltage switching device or pricing logics identified by optimization systems to enhance self-consumption. If there has been a grid fault, the circuit breaker trips for interface protections<sup>2</sup>, otherwise it opens for local/remote opening command. In case of fault, the grid voltage value decreases significantly, so usually the loads adsorb less power and the generators produce more power. As a result, the dynamic of the transient is slower than in the other situations. Having more time to take actions, Emax 2 sees the frequency trend after the fault and starts load shedding only if detects the frequency slope exceedance of the first under-frequency (UF1) threshold. Having both frequency slope detection and under frequency limit makes the load shedding sensitive neither for short-time disturbance nor for emergency conditions.

In other cases, the frequency decreases with high speed, so there is not any more time for Emax 2 to understand how the Microgrid is evolving with running generation. This is also the case of ATS: when the back-up generator reconnects to the Microgrid, it has to face all the loads, even if it is sized for a plant load percentage.

<sup>2</sup> See White Paper 1SDC007117G0201 – Interface Protection System and Interface Device

## 2. Load Shedding

If the triggers have been detected, the loads are fast shed according to Equation 1.

Equation 1

$$\Delta P_{\text{SHED}} = \sum_{n=1}^N P_n s_n \geq P_{\text{Grid}} + P_{\text{solar}} - P_{\text{gen\_ATS}}$$

- $\Delta P_{\text{SHED}}$  is the amount of load power to be shed, adapted to the load-flow scenario. In particular, it is equal to the sum of the power of the minimum number (N) of loads that can cover the load shedding power request. In other words, it is the result of power unbalance calculation.
- $P_{\text{Grid}}$  is the measured power that has been absorbed from the grid before the opening event. Emax 2 is configured top-bottom, so it uses the load convention.
- $P_{\text{solar}}$  is the estimated power of the photovoltaic plant in the Microgrid. It can be disconnected after the islanding for internal protections of the static converters, so there is a power gap in the system.

The solar power calculation is based on a few details edited by the user during commissioning (see 5) :

- Geographic position
- Date and time
- Solar panels inclination and orientation
- Solar plant size

Emax 2 analyzes this information and gives a conservative sunny daily power profile.

- $P_{\text{gen\_ATS}}$  is the power of the back-up generator in the main – gen ATS architectures, or energy storage systems in general. This is a parameter inserted by the user during commissioning (see 5)).
- $P_n$  is the usage power of the n-load. It is obtained as the product of the nominal power and the usage factor depending on the kind of loads. These are not priority loads, possible to be turned off in emergency situations, for example thermal loads like air conditioning units, ovens, freezing cells or pumps, air compressors, chillers, non-emergency lights.
- $s_n$  is the status (open/closed) of the n-load device. For instance, if it is open, it is set to zero since it is not involved in the power to be shed calculation.

Whenever frequency continues to decrease and a back-up under second under frequency threshold (UF2) is exceeded, Emax 2 disconnects all the controlled loads not previously open in order to avoid as well as possible a blackout.

## 3. Load reconnecting

It is the same procedure of Basic Load Shedding (see 4.1.1).

# Emax 2

## Load Shedding innovation

### Ekip Connect 3.0 commissioning tool

Ekip Connect 3.0 simplifies complex programming, which is an emblematic barrier for the adoption of advanced functions with other devices.

The user can find load shedding functions inside the “Tools section” and select the desired setup. It is possible to configure the load shedding function even if the SW license has not been already bought, so as to let the user make practice and see if the algorithm fits with the requirements prescribed for the Microgrid. On the other side, there is the chance to save projects in dedicated files and upload them for other people and in other plants, leaving the greater flexibility for every application.

Basic Load Shedding is available with in Emax 2 circuit breaker, so it is possible to boost performances with Adaptive Load Shedding.

Figure 14: select load shedding function

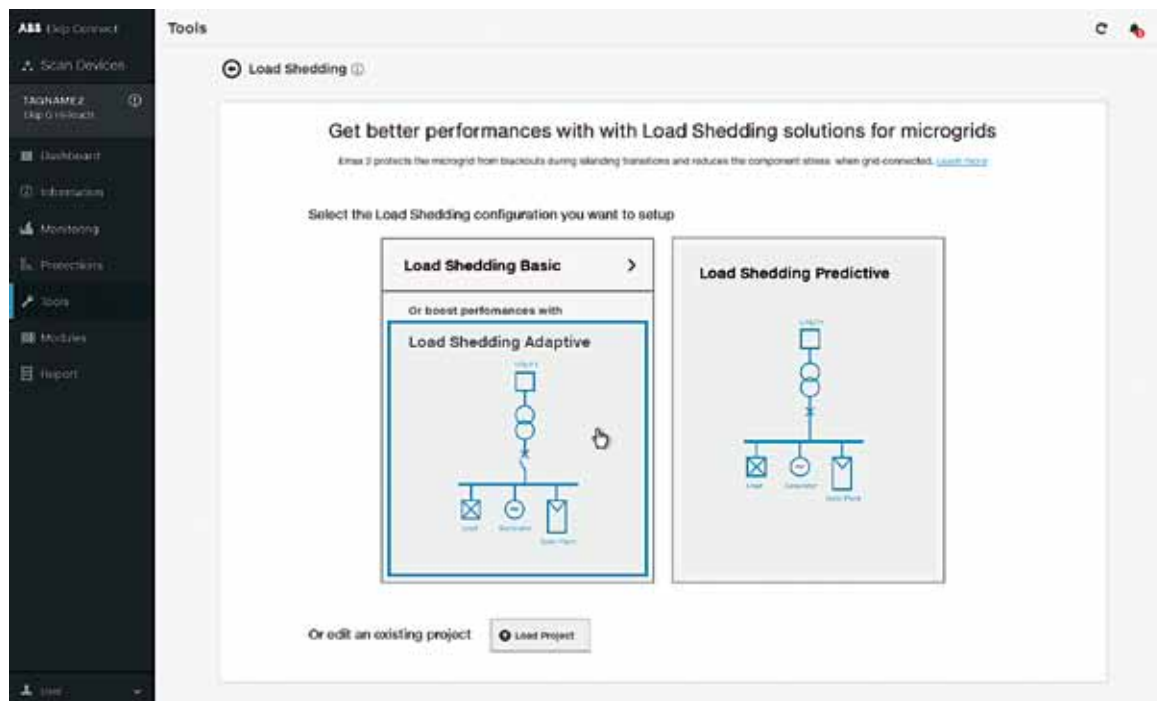
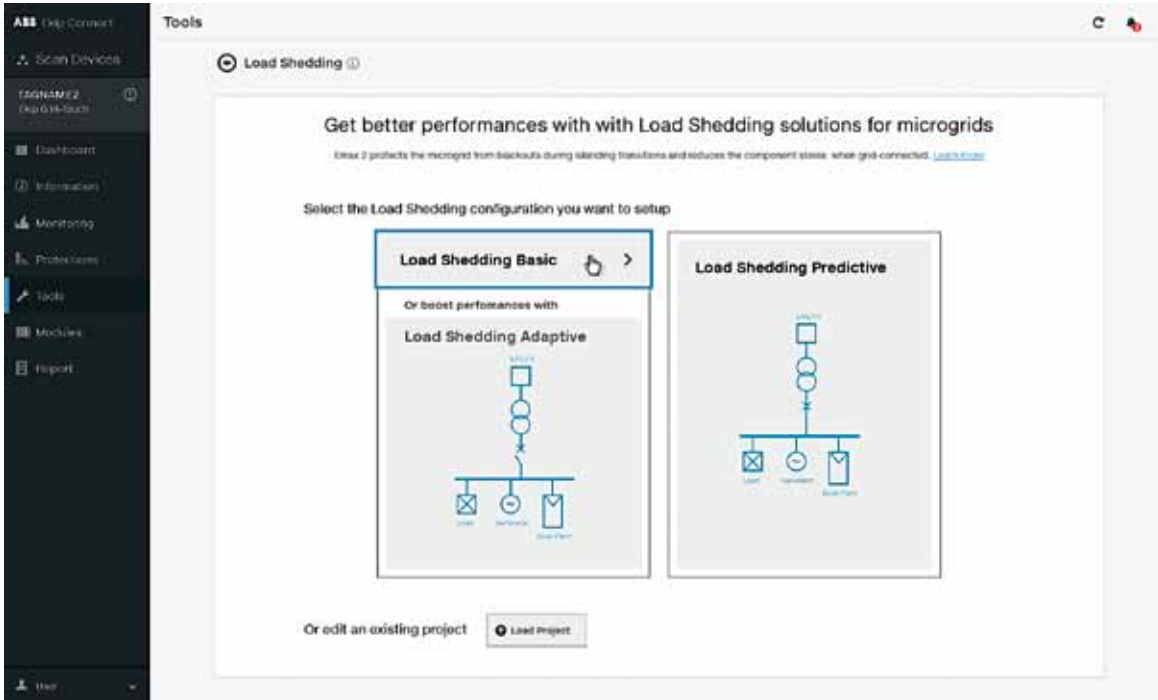




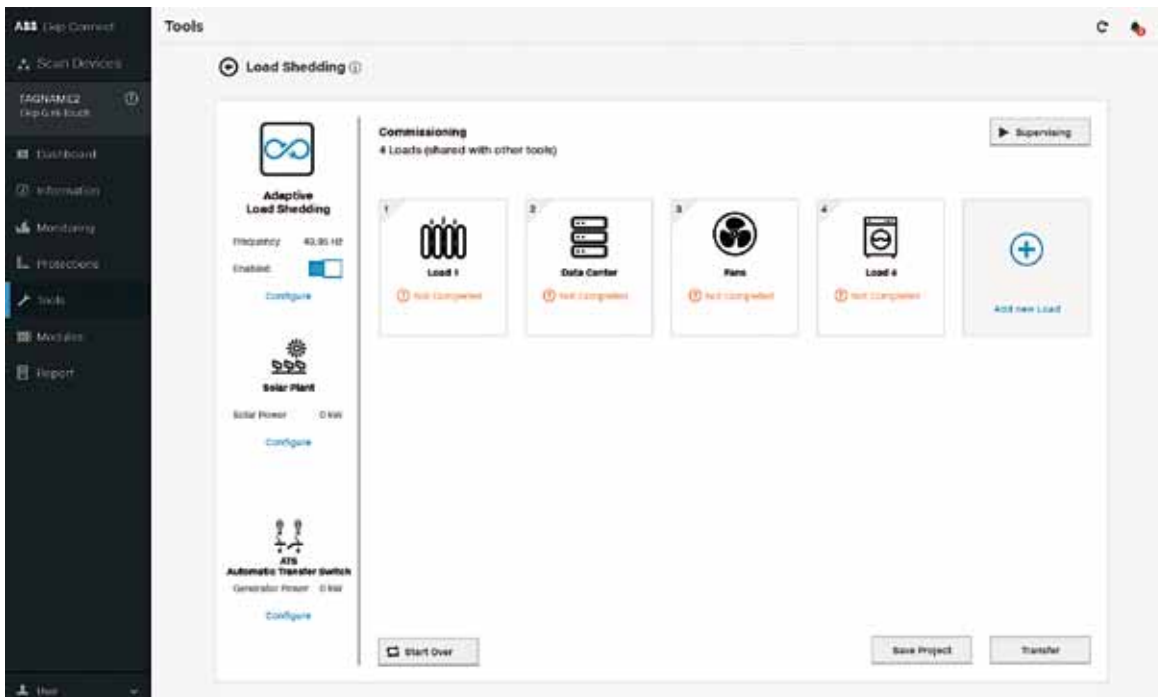
Figure 15: if Basic Load Shedding has been selected, it is continuously possible to try Adaptive Load Shedding



The Ekip Connect tool have two sessions for load shedding: one for the commissioning stage and another for supervising when the plant is running.

During commissioning, if other compatible tools are already enabled, some parameters are already acquired, without repeating twice the same configuration.

Figure 16: commissioning of Adaptive Load Shedding with some loads shared with other tools



# Emax 2

## Load Shedding innovation

Adaptive Load Shedding setup is divided into 2 steps:

1) Configuration of Emax 2 settings for load shedding

Figure 17: main settings of Emax 2, Adaptive Load Shedding

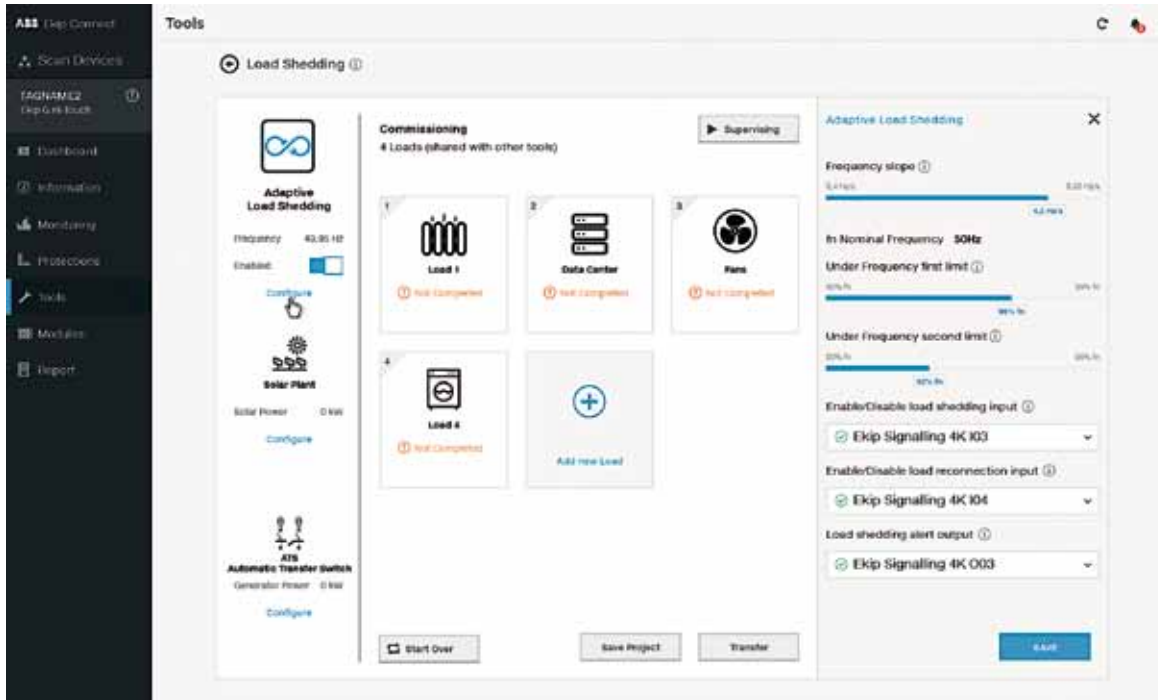


Figure 18: solar plant estimation parameters

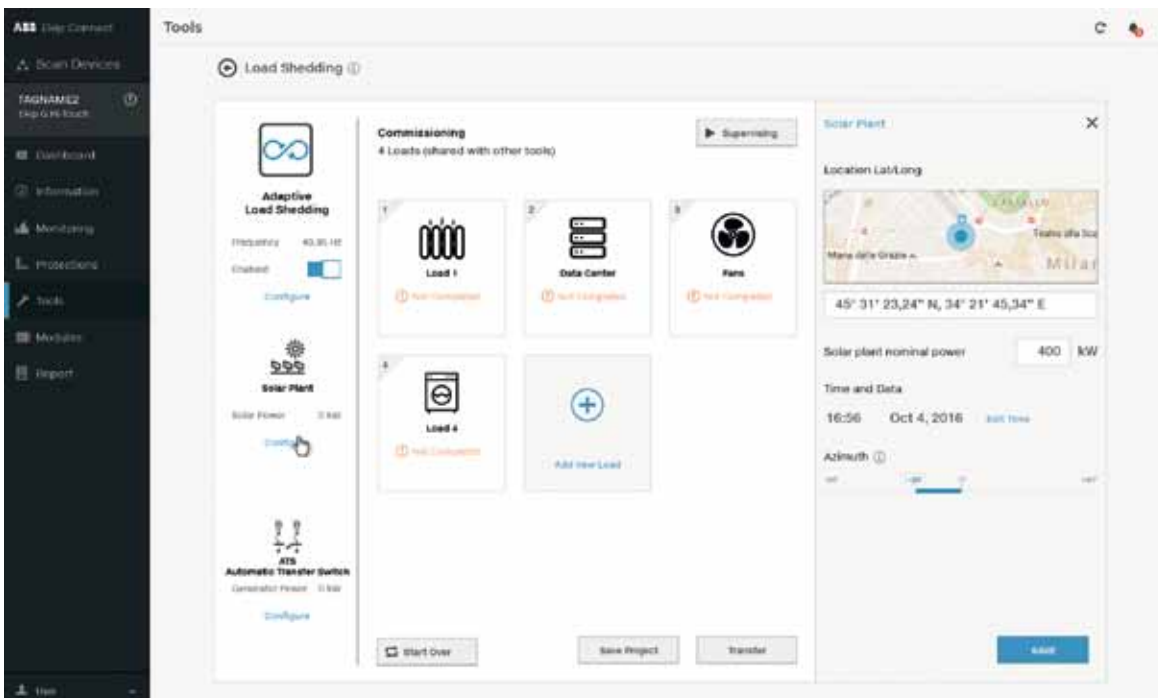
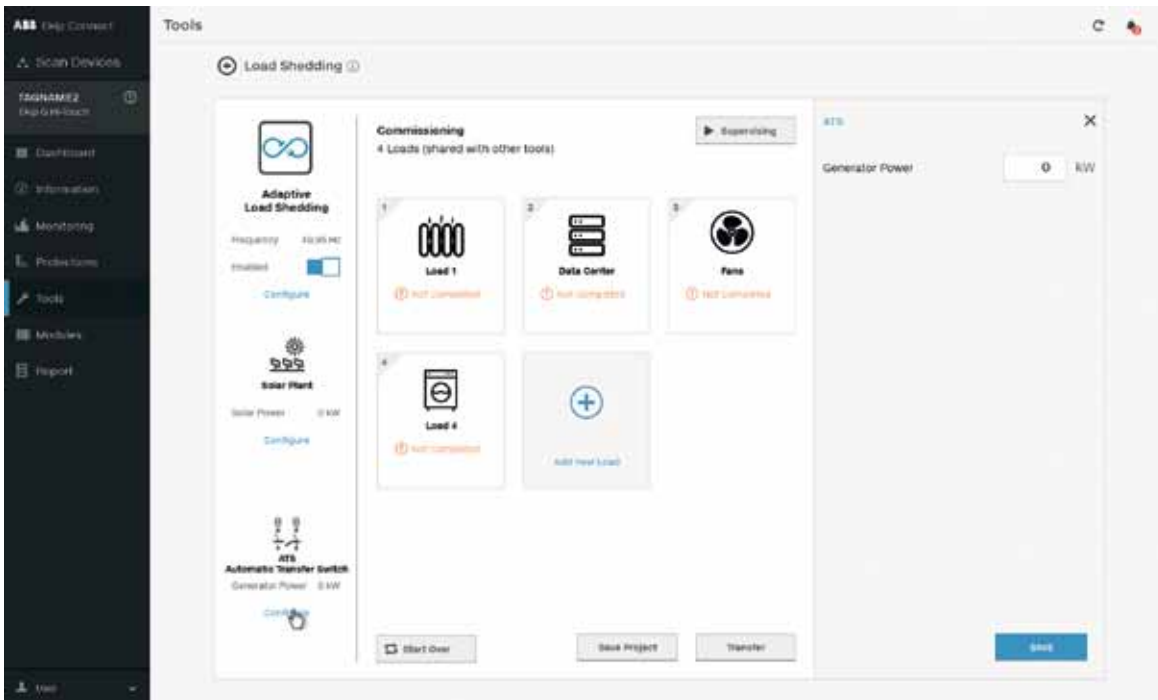


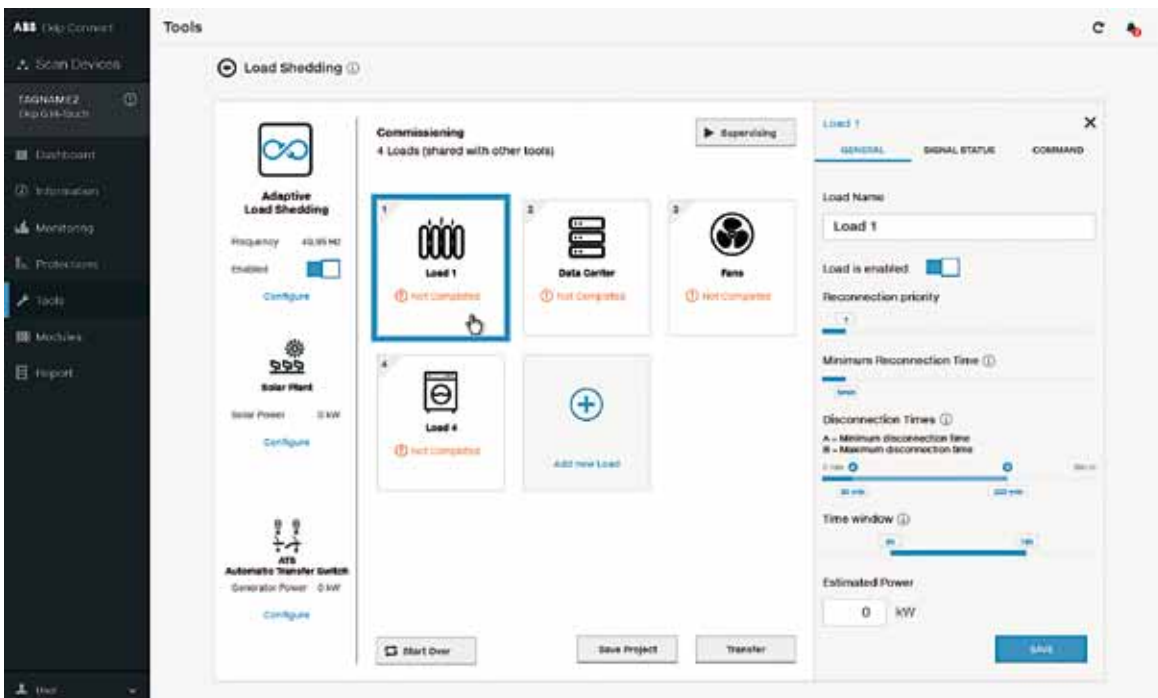
Figure 19: ATS back-up generation definition<sup>1</sup>



<sup>3</sup> If it set as "0 kW", it means there is not any ATS back up generation in the Microgrid.

2) Configuration of controlled loads

Figure 20: general classification with time constraints



# Emax 2

## Load Shedding innovation

Figure 21: signal status definition

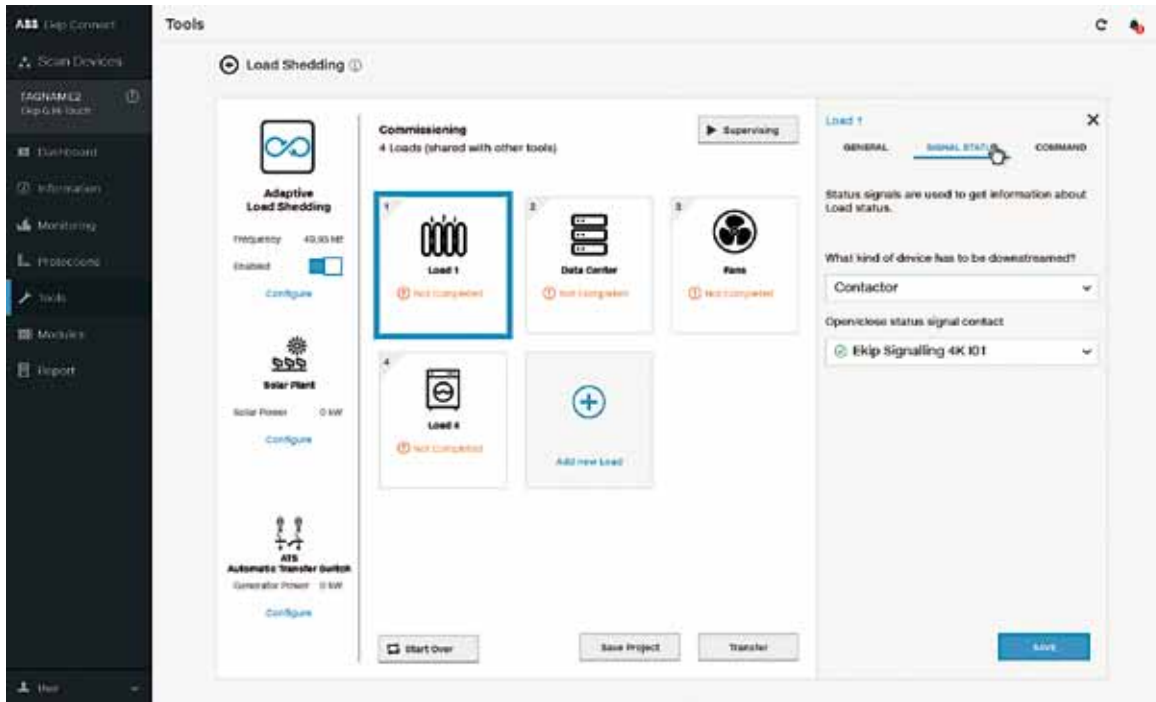
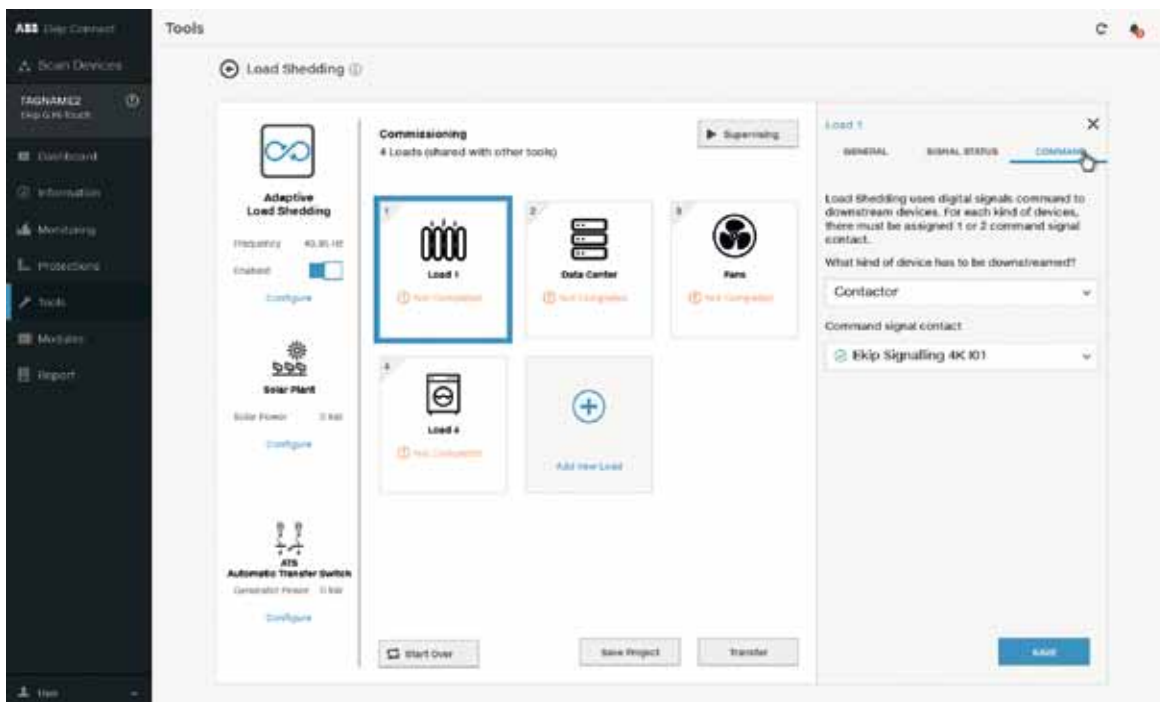


Figure 22: command to each load device settings



After commissioning, the logics can be easily transferred to the circuit breaker, if the SW license has already been purchased and there is the possibility to see how it works with the supervising widgets. They represent the controlled loads, the yearly peak solar power estimation and the real-time Microgrid frequency values.

Figure 23: transfer of Adaptive Load Shedding logics to Emax 2

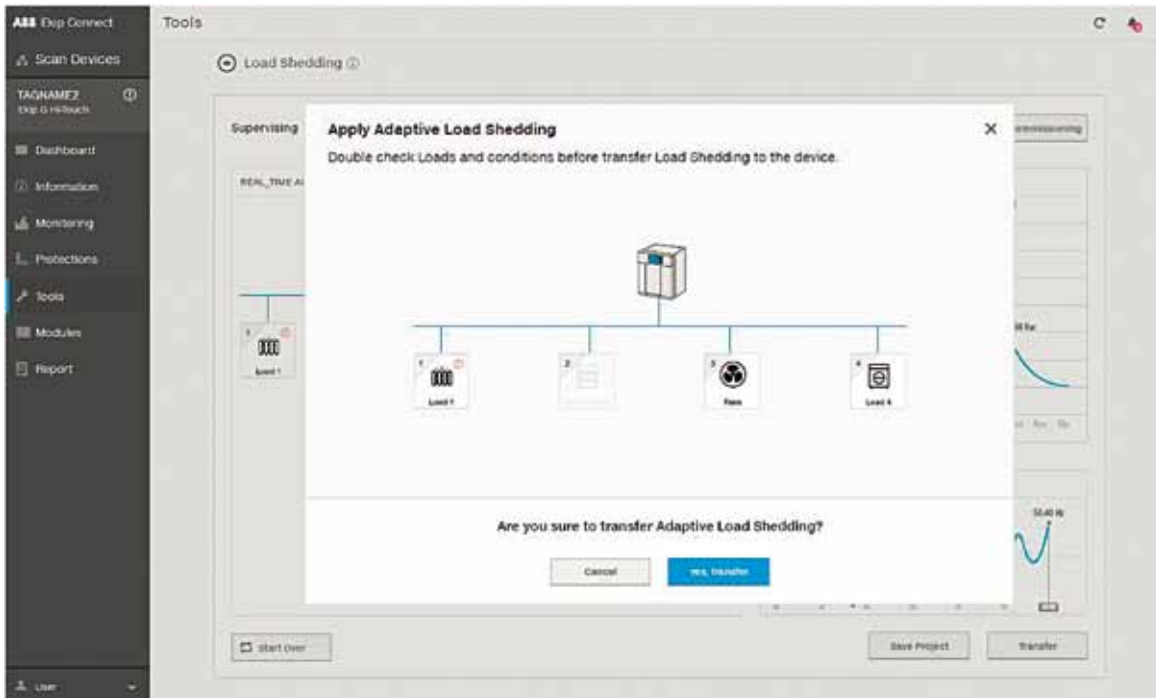
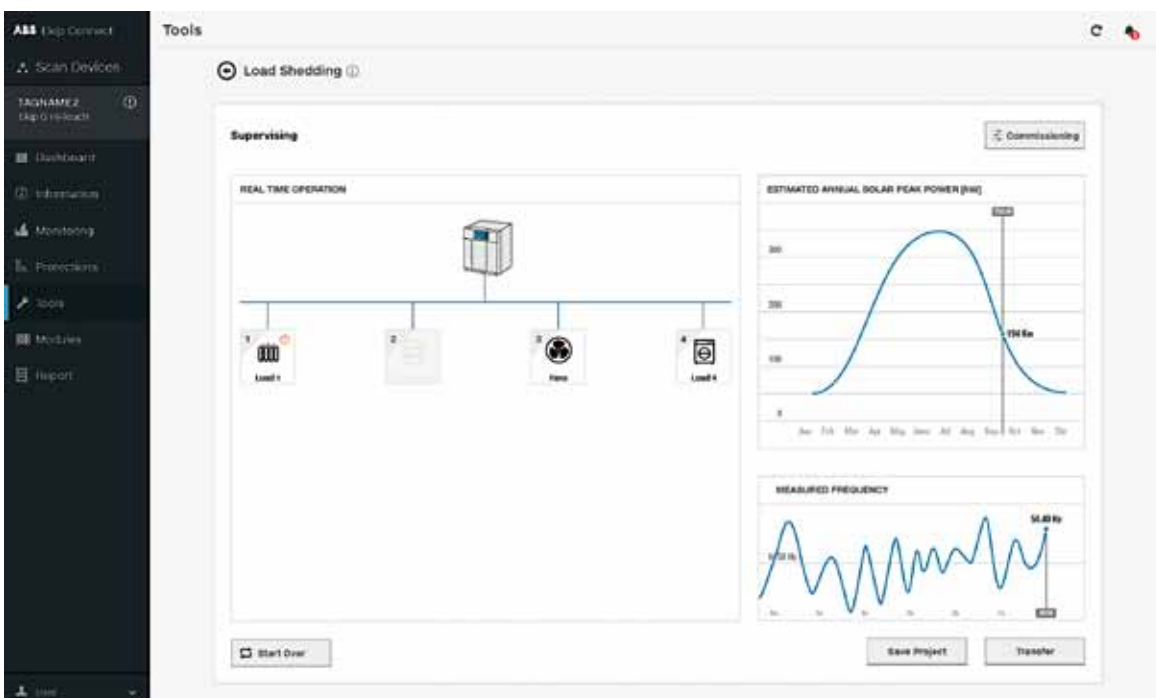


Figure 24: supervising widget



# Emax 2

## Load Shedding innovation

### Application example of Adaptive Load Shedding

#### Industry

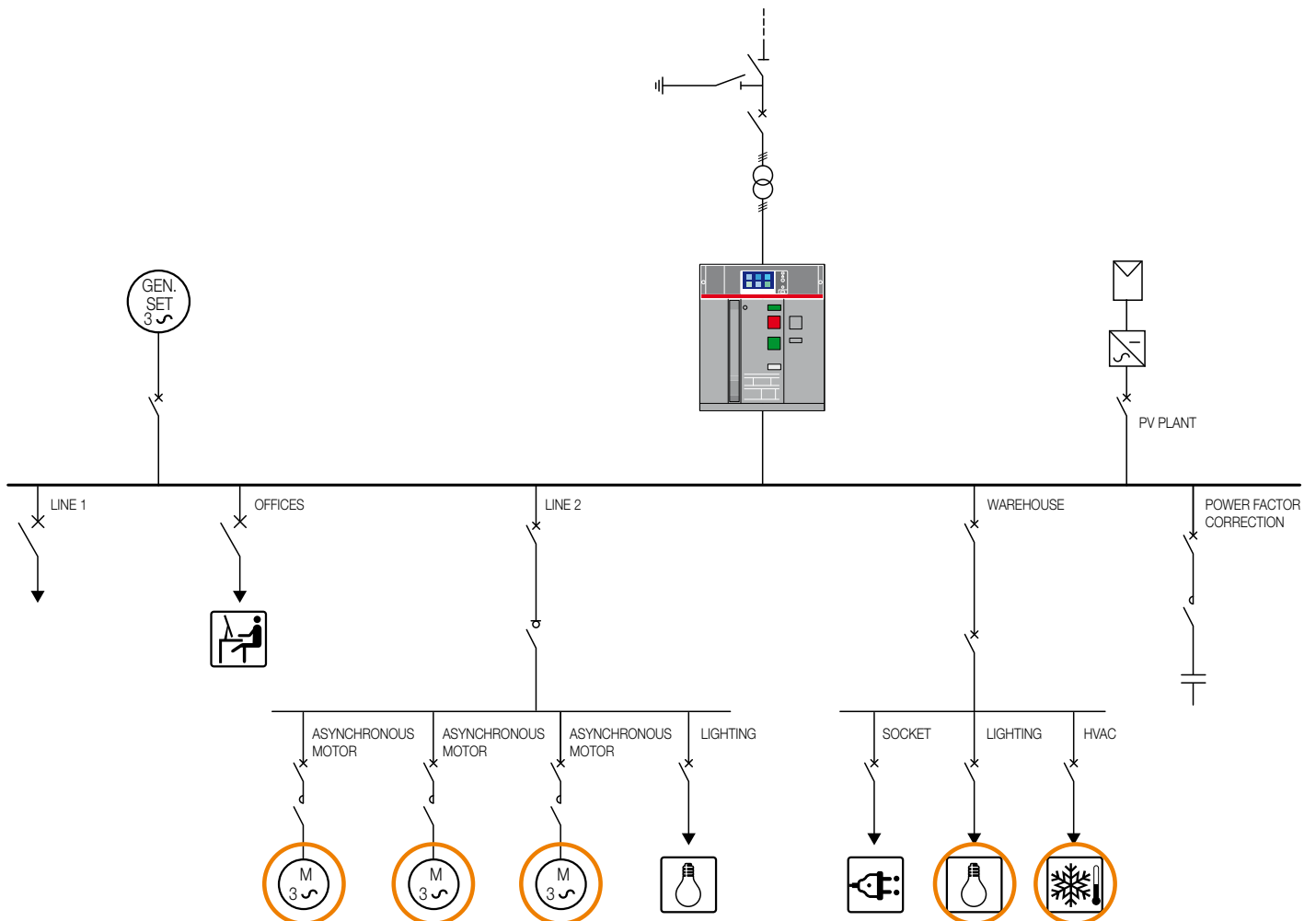
This application example refers to an industry connected to the MV Utility through a MV/LV transformer (15kV/400V). As shown in Figure 24, in such plant there are a GenSet (An = 625 kVA, Pn = 500 kW) and a PV plant (Pn = 100 kW) which are in parallel with the Utility during the grid-connected operation. The total active power consumed by the loads is 1000kW, so the power absorbed from the grid in a sunny day is equal to 400kW. As a result, the total power of the non-priority loads must be at least 500 kW (sum of the power flowing from the grid with the PV plant nominal power<sup>4</sup>).

The main circuit breaker Emax 2 - installed immediately downstream of the MV/LV transformer and equipped with Interface Protection System feature – is an E1.2C Iu = 800 A.

There are two production lines: Line 1 and 2. Line 1 feeds the priority loads belonging to a continuous production process, so they cannot be controlled by the Load Shedding during islanding operation. Instead, Line 2 feeds non-priority loads which can be managed by the Load Shedding by means of contactors, installed on the power circuit of the corresponding asynchronous motors. Moreover, in the warehouse, there are several loads (e.g lighting and HVAC) that can be controlled by the Load Shedding by means of circuit breakers.

<sup>4</sup> As said before, it is assumed that the PV plant stops its power delivering during islanding operation due to the inverter stand-by self-protection.

Figure 25



The reconnection priority and the controlled devices chosen by the Customer are shown in Table 1:

**Table 1**

Reconnection Priority	Load	Nominal Power [kW]	Load Factor	Total Power [kW]	Controlled device
1	HVAC	3 x 50	0.8	120	MCCB
2	Lighting	3 x 30	1	90	MCB
3	Conveyor belt – Asynchronous motor	100	0.9	90	Contactora
4	Air compressor 1 – Asynchronous motor	140	0.8	112	Contactora
5	Air compressor 2 – Asynchronous motor	120	0.8	96	Contactora
				<b>508</b>	

Figure 26 shows the frequency variation diagrams during the islanding operation in the following two cases:

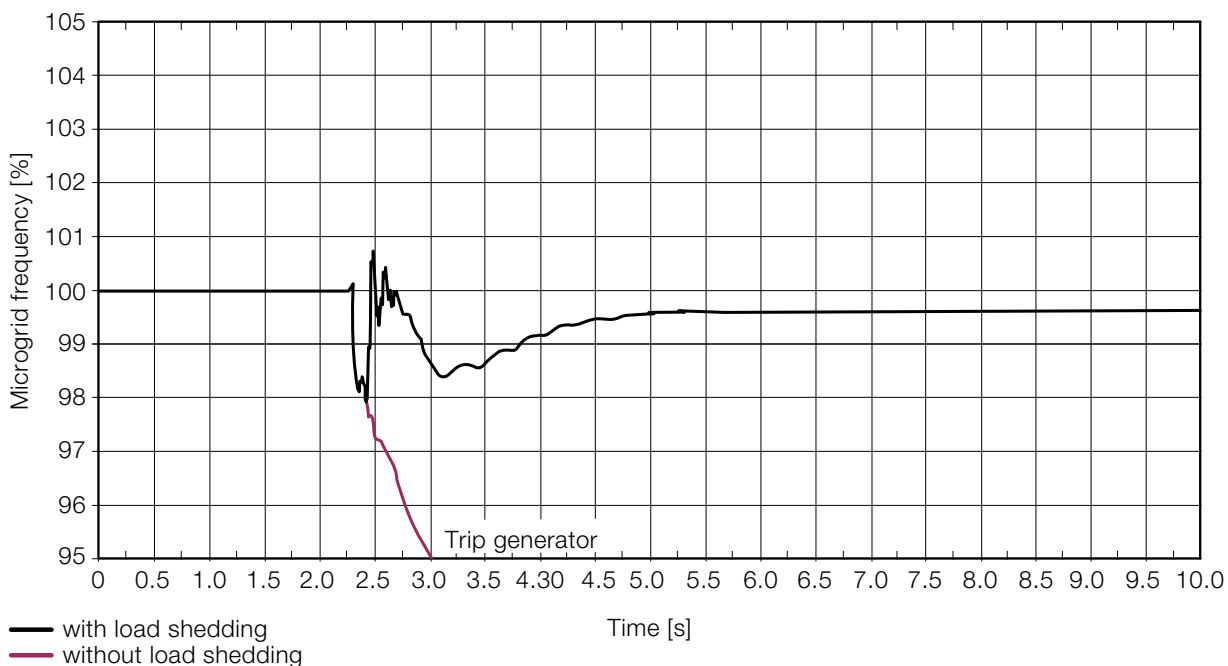
- without load shedding feature (Red Line)
- with load shedding feature (Blue Line)

As it can be seen, in the first case, moving from grid-connected to islanding operation, there is a frequency reduction due to a power absorption by the passive loads higher than the power produced by the GenSet. As a result, as soon as the frequency reaches the undervoltage threshold of the circuit breaker installed on the generator feeder, there will be a shutdown of the whole microgrid.

Instead, in the second case and thanks to the Load Shedding feature, as soon as the main circuit breaker Emax 2 opens, the algorithm disconnects a number of non-priority in order to have a power balance between the power absorbed and local generated. As a result, the frequency decrease is reduced and stopped to a value higher than in the previous case. Hence, the frequency protection does not trip and the Microgrid remains live.

Then, when the main circuit breaker Emax 2 recloses, the Load Shedding feature will reconnect all the loads according to the priority list.

**Figure 26**



# Emax 2

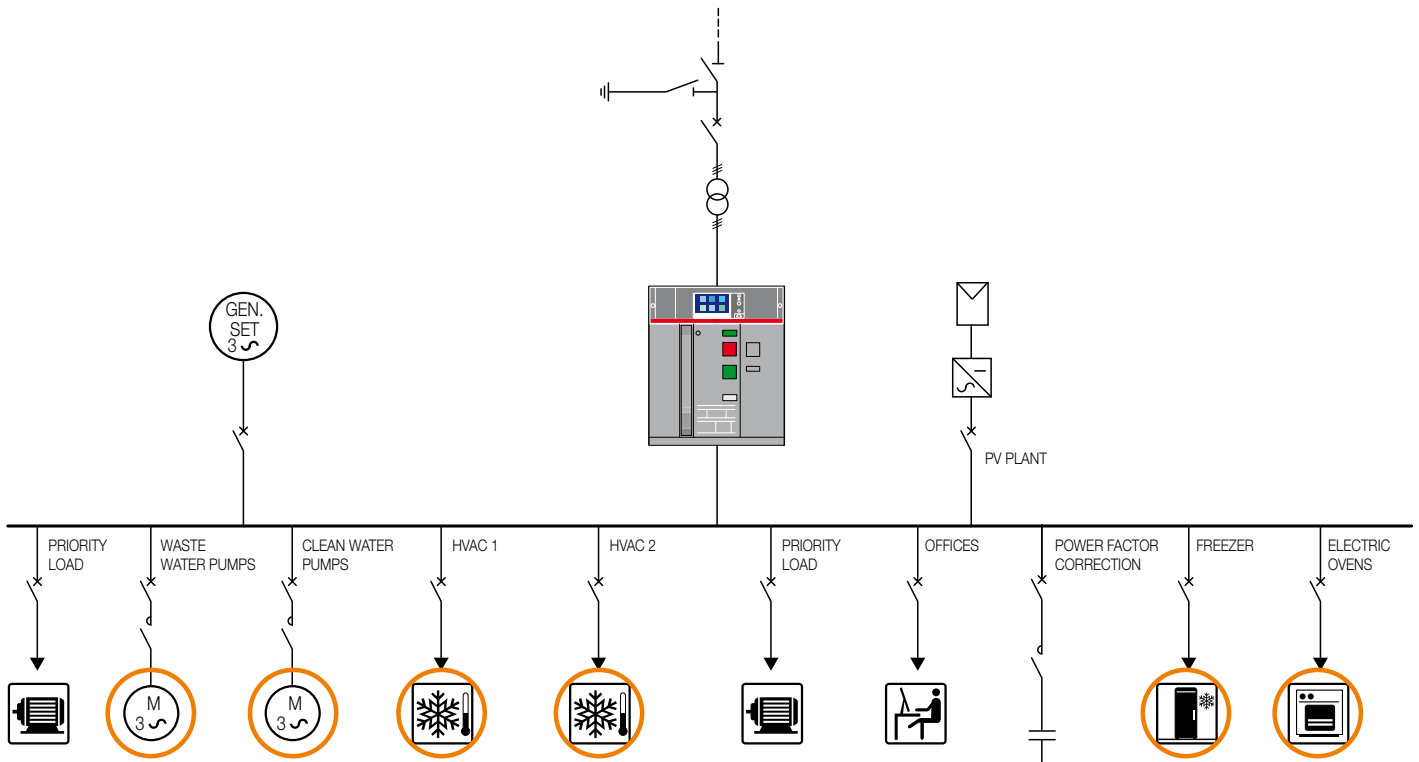
## Load Shedding innovation

### Building

This application example refers to an office building connected to the MV Utility through a MV/LV transformer (15kV/400V). As shown in Figure 26, in such plant there is a PV plant ( $P_n = 100 \text{ kW}$ ) connected in parallel with the Utility during the grid-connected operation. There is also a GenSet ( $A_n = 625 \text{ kVA}$ ,  $P_n = 500 \text{ kW}$ ) which is connected by the ATS when the main circuit breaker Emax 2, installed immediately downstream of the MV/LV transformer, opens. The total active power adsorbed by the loads is 1000kW; therefore, the power adsorbed from the grid in a sunny day is equal to 900kW. As a result, the total power of the non-priority loads must be at least 500 kW (difference between the total power of the loads and the nominal generator power<sup>5</sup>).

<sup>5</sup> Even in this case, it is assumed that the PV plant stops power delivering during islanding operation due to the inverter stand-by.

Figure 27



The reconnection priority of the non-priority loads and the controlled devices chosen by the Customer are shown in Table 2.

Table 2

Reconnection Priority	Load	Nominal Power [kW]	Load Factor	Total Power [kW]	Controlled device
1	HVAC1	3 x 50	0.7	105	MCCB
2	HVAC2	3 x 50	0.7	105	MCCB
3	Clean water pumps – Asynchronous motor	170	0.8	136	Contactora
4	Waste water pumps – Asynchronous motor	170	0.8	136	Contactora
5	Freezer	12	0.9	10.8	MCB
6	Electric ovens	12	0.9	10.8	MCB
				<b>503.6</b>	



Figure 28 shows the frequency variation diagrams during islanding operation in the following two cases:

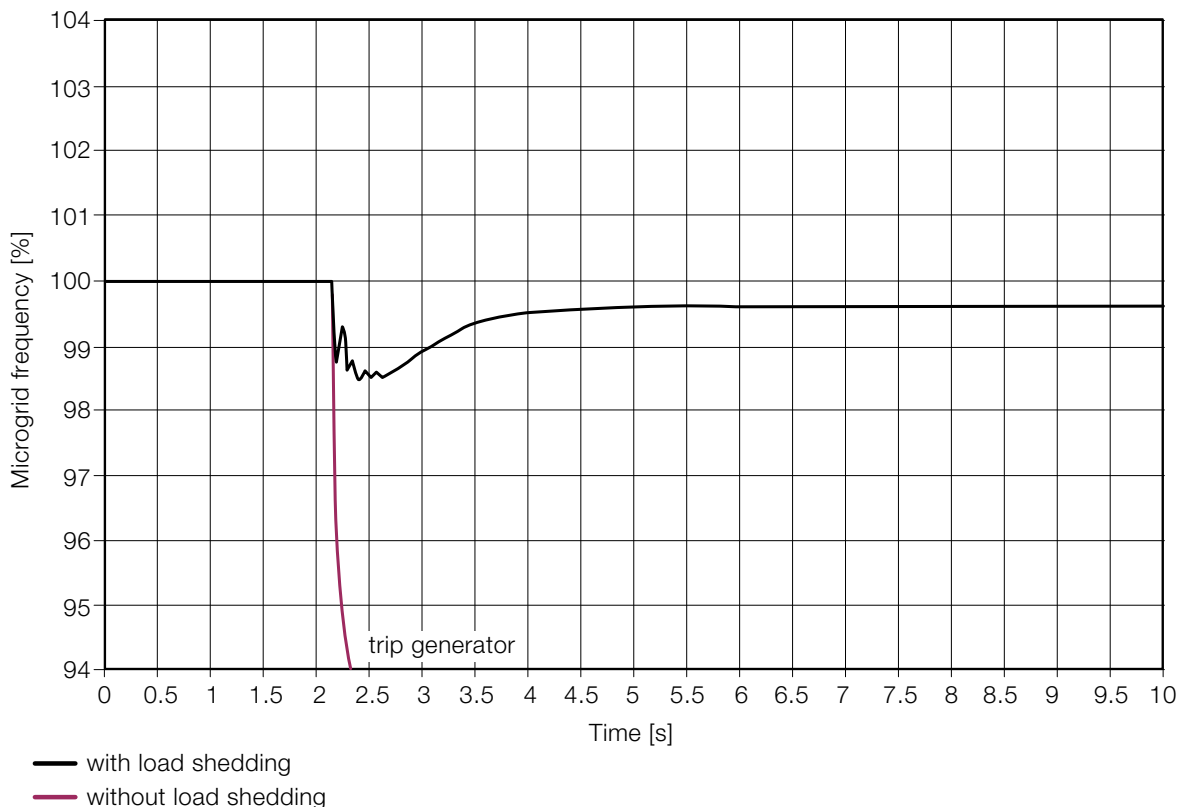
- without load shedding feature (Red Line)
- with the load shedding feature (Black Line)

As it can be seen, in the first case, moving from grid-connected to islanding operation, there is a short time interval during which the loads are not supplied until the ATS has activated the GenSet. Nevertheless, even if the GenSet starts to deliver its maximum power, the frequency decreases due to a power absorption by the passive loads higher than the power produced. As a result, as soon as the frequency reaches the undervoltage threshold of the circuit breaker installed on the generator feeder, there will be a shutdown of the whole microgrid.

Instead, in the second case, after the brief power interruption, the algorithm disconnects a number of non-priority loads to ensure power balance between the power absorbed and local generated. As a result, the frequency decrease is reduced and stopped at a value higher than in the previous case. Hence, the frequency protection does not trip and the Microgrid remains active.

Then, when the main circuit breaker Emax 2 recloses, the Load Shedding feature reconnects all the loads according to the priority list.

Figure 28



# Emax 2

## Load Shedding innovation

### Electrical diagrams

In the algorithm architecture, Emax 2 sends inputs to the non-priority load devices to realize the load shedding and outputs to each one for their reconnection. From the other side, it receives the load status and tripped indication, where available, from the load devices.

The connection among Emax 2 and the load devices is realized by traditional wiring using Ekip Signalling modules. The number of Ekip Signalling depends on the number of loads controlled. The load devices that can be shed are those of the Table 3, either if ABB product or not.

**Table 3: load device controlled**

Product family	Accessory required	Emax 2 I/O used
Molded case circuit breaker ABB example: Tmax XT, Tmax T equipped with MOD or MOE	Motor operator, open/closed contact, released tripped contact	2
Air circuit breaker ABB example: Emax, Emax 2	Charging coil motor, opening/closing coil, status contact, release tripped contact	2
Contactors ABB example: AF	Auxiliary contact	1
Switches ABB example:: OTM	Motor operator, auxiliary contact	1
Miniature circuit breaker ABB example:: S200 equipped with S2C-CM, DS200 equipped with DS2C-CM, S800 equipped with S800-RSU-H	Auxiliary power supply, motor operator, open/closed contact (if not included in the motor).	1
I/O interface Example: drives	Digital input contact	1

If the loads under control are many and therefore the integrated I/O are not enough or if they are far from the Emax 2 cabinet, it is possible to connect them through Ekip Signalling 10K. This Din-rail module is connected to Emax 2 either by the local bus for short distance or by Ekip Link, using standardized Ethernet cable in case of long distances.

Figure 28: example of switchboard design for Emax 2 Load Shedding

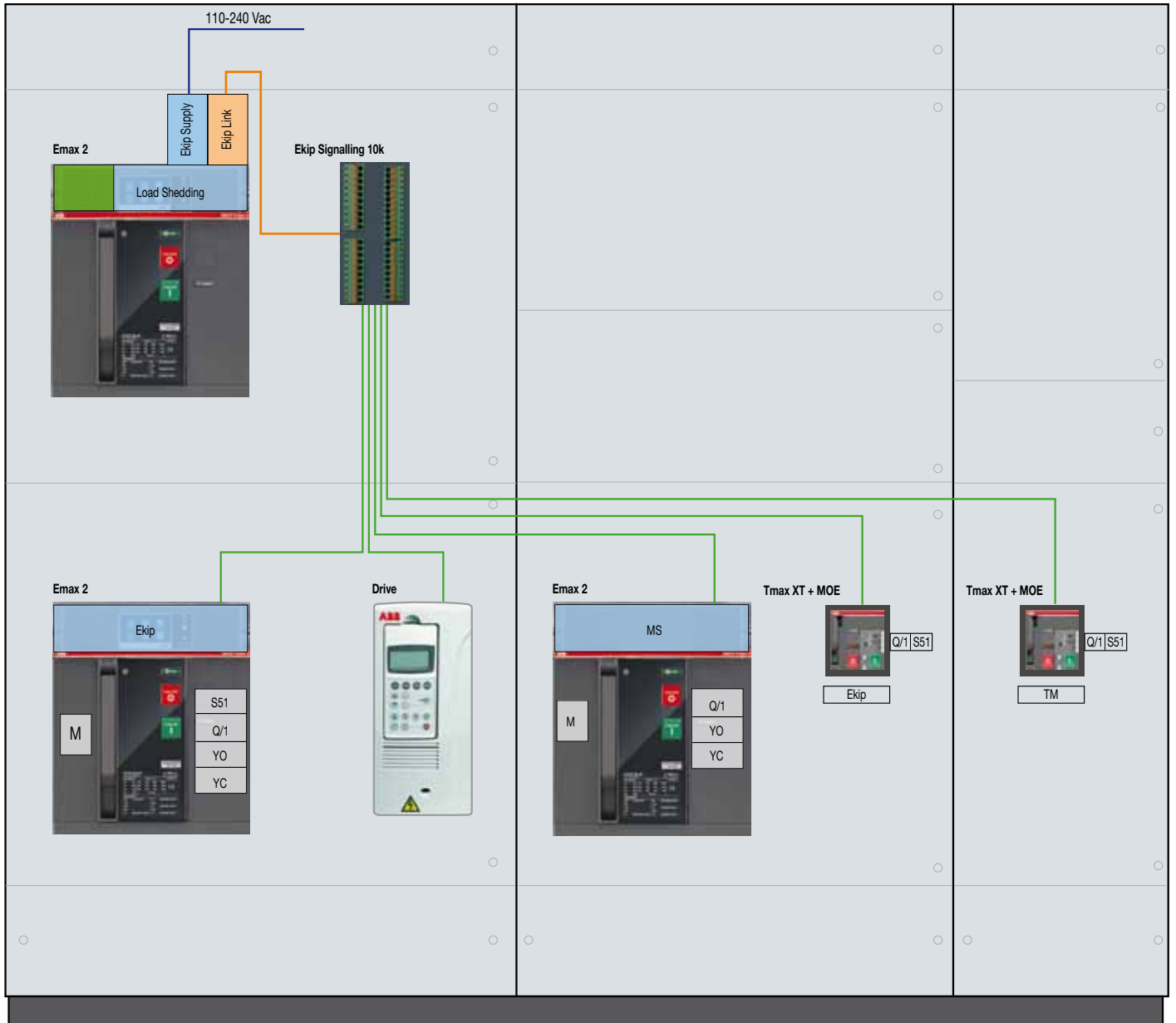


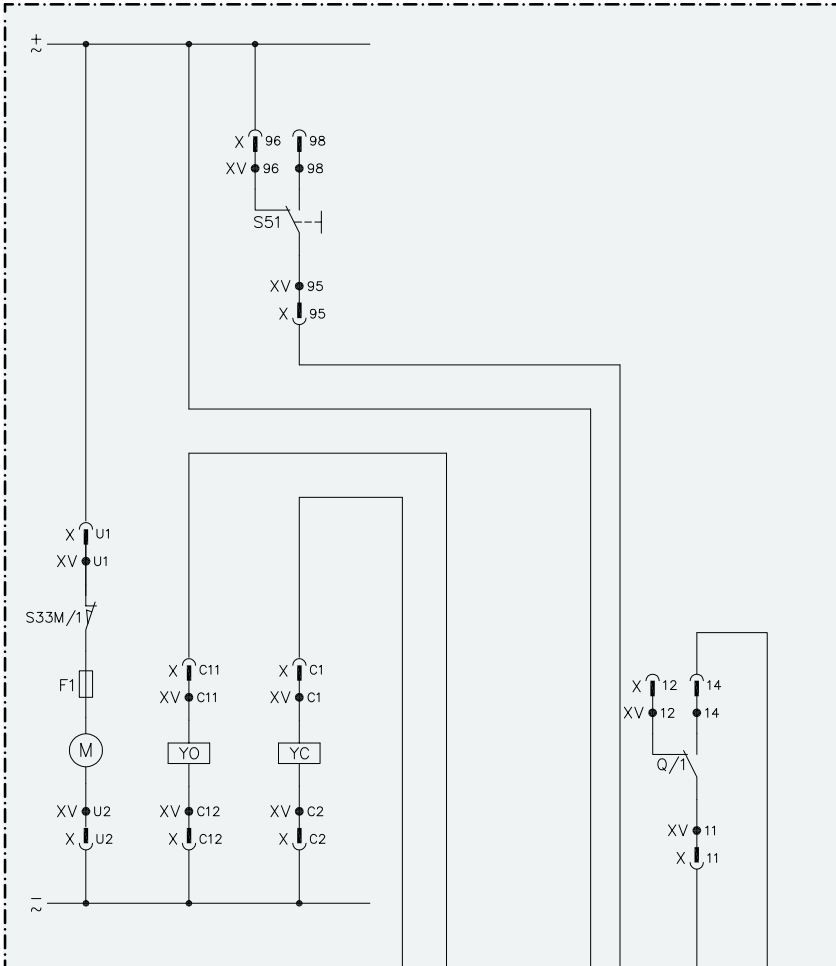
Figure 28 shows a schematic circuit diagram with an example of the load shedding architecture. Emax 2 equipped with the load shedding is the main circuit breaker that controls four circuit breakers (two air circuit breakers and two molded case circuit breakers) and one drives on the load side. These ones are commanded by traditional wirings using Ekip Signalling 10k, that is peer-to-peer Ethernet wired to the Ekip Link cartridge module of Emax 2.

# Emax 2

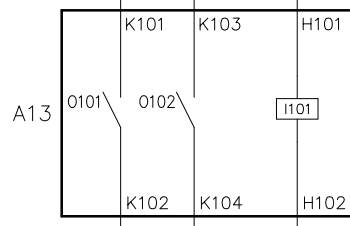
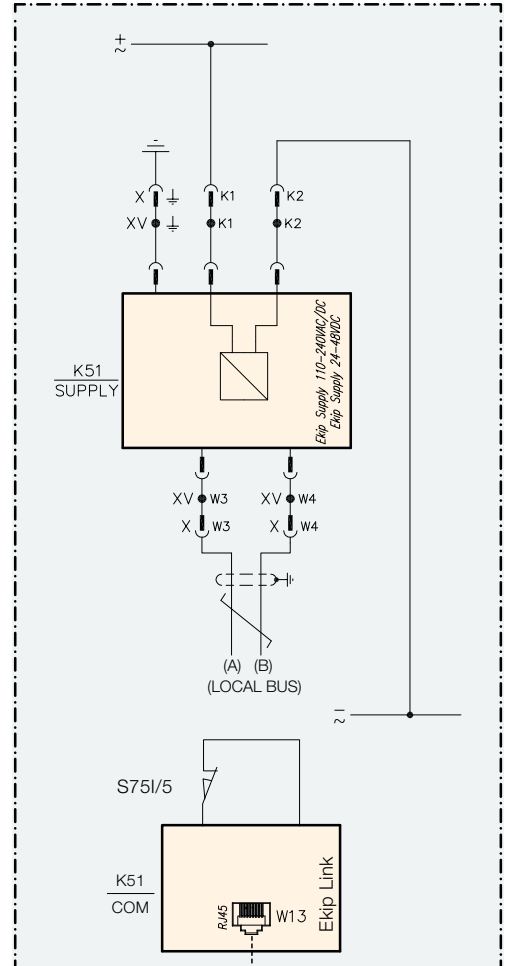
## Load Shedding innovation

Figure 29: example of electrical diagram for Emax 2 Load Shedding

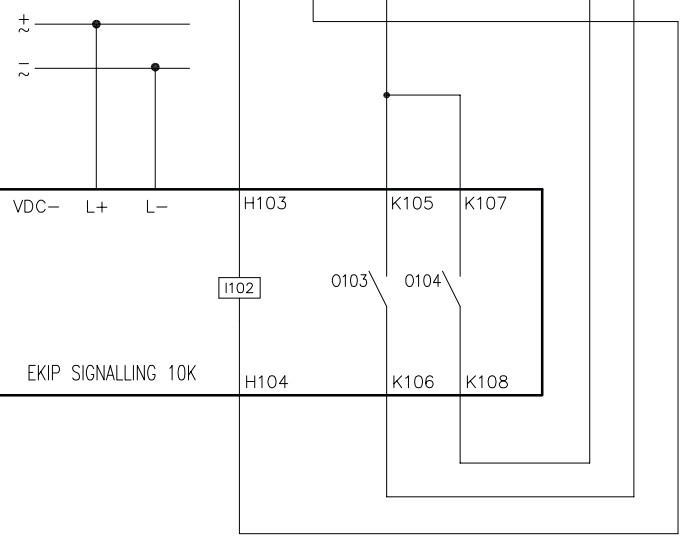
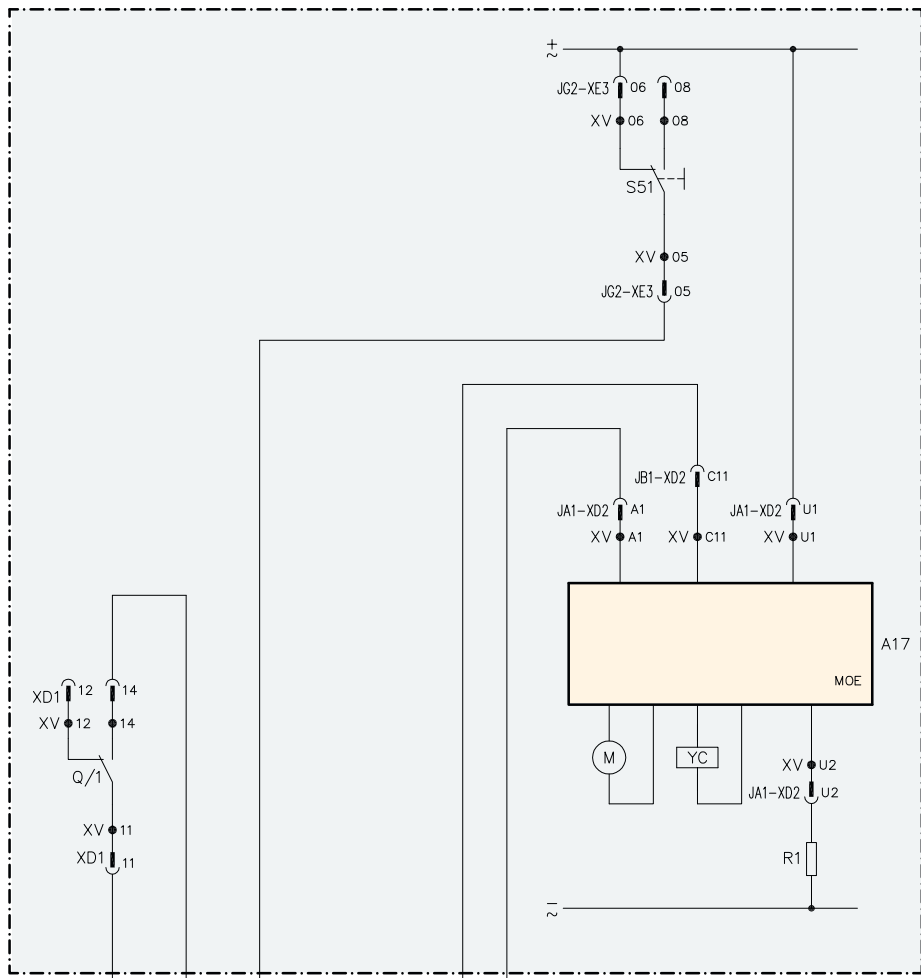
### Q2 - Emax 2



### Q1 - Emax 2 + Adaptive Load Shedding



**Q3 - Tmax XT + MOE**



# Emax 2

## Load Shedding innovation

### Shopping List

The load shedding algorithms can be easily used Emax 2 thanks to a plug&play business model.

The Basic Load Shedding is always available in the circuit breaker equipped with the right hardware and can be configured directly by Ekip Connect.

The Adaptive Load Shedding can be ordered directly for new breaker or uploaded for upgrade switchgear already commissioned. In this case, the SW license present in the USB key unlocks the settings transfer to the breaker by Ekip Connect 3.0.

**Table 4: shopping list for Emax 2 Load Shedding**

Description	Product	Commercial Codes	Notes <sup>6</sup>
Trip unit	Ekip Touch + Ekip Measuring	Embedded in Emax 2 circuit breaker	Otherwise, Ekip Hi Touch, Ekip G Touch, Ekip G Hi Touch family
Power supply	Ekip Supply 110-240V AC/DC	1SDA074172R1	As an alternative Ekip Supply 24-48V DC (1SDA074173R1)
I/O contacts	Ekip Signalling 10k	1SDA074171R1	As an alternative, depending on the number of I/O required in the architecture, Ekip Signalling 4k (1SDA074170R1) <sup>7</sup> or Ekip Signalling 2k <sup>8</sup> (1SDA074167R1, 1SDA074168R1, 1SDA074169R1)
Ethernet communication	Ekip Link	1SDA074163R1	Optional if used with Ekip Signalling 10k with Ekip Link interface
SW license USB key	Basic Load Shedding	Already installed in Emax 2	
SW license USB key	Adaptive Load Shedding	1SDA082921R1	

<sup>6</sup> For every commercial codes, see 1SDC200023D0204 for IEC and 1SDC200039D0201 for UL.

<sup>7</sup> Available for E2.2-E6-2 frames.

<sup>8</sup> Up to 2 modules for frame E1.2, up to 3 modules for frame E2.2-E6.2.



# Contact us

For more information please contact:

**ABB SACE**

**A division of ABB S.p.A.**

**L.V. Breakers**

Via Pescaria, 5

24123 Bergamo - Italy

Tel.: +39 035 395 111

Fax: +39 035 395306-433

**[www.abb.com](http://www.abb.com)**



The data and illustrations are not binding. We reserve the right to modify the contents of this document on the basis of technical development of the products, without prior notice.

Copyright 2016 ABB. All rights reserved.

1SDC007119G0201 - 10/2016