

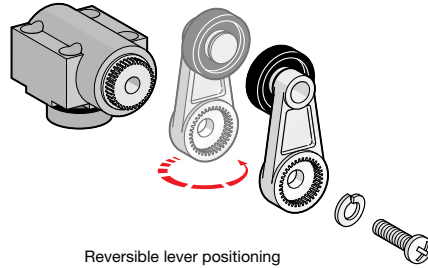

**General technical data**  
Limit switches

# Technical data Implementation



Reversible lever positioning

9

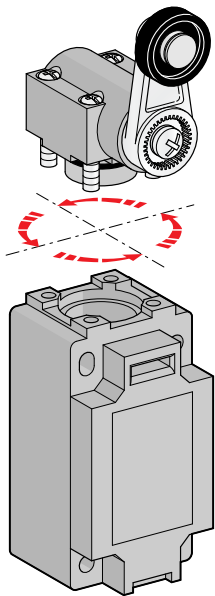

90° head orientation

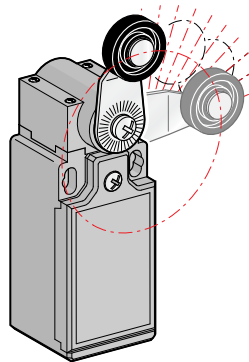

Free position adjustment of lever

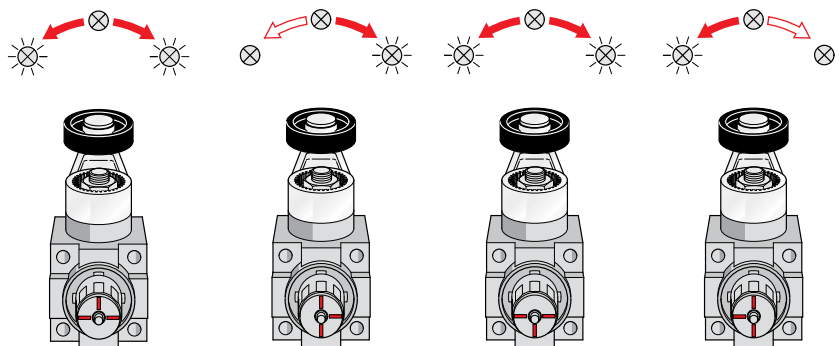
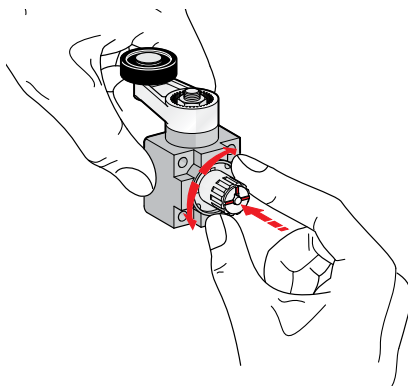
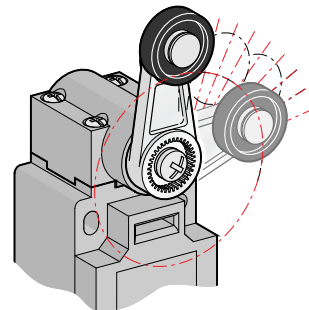

### Double insulation

Class II materials, according to IEC 536, are designed with double insulation. This measure consists in doubling the functional insulation with an additional layer of insulation so as to eliminate the risk of electric shock and thus not having to protect elsewhere. No conductive part of "double insulated" material should be connected to a protective conductor.

### Positive opening operation

A control switch, with one or more break-contact elements, has a positive opening operation when the switch actuator ensures full contact opening of the break-contact. For the part of travel that separates the contacts, there must be a positive drive, with no resilient member (e.g. springs), between the moving contacts and the point of the actuator to which the actuating force is applied.

The positive opening operation does not deal with N.O. contacts.

Control switches with positive opening operation may be provided with either snap action or slow action contact elements. To use several contacts on the same control switch with positive opening operation, they must be electrically separated from each other, if not, only one may be used. Every control switch with positive opening operation must be indelibly marked on the outside with the symbol: .

### Snap action

Snap action contacts are characterized by a release position that is distinct from the operating position (differential travel). Snap breaking of moving contacts is independent of the switch actuator's speed and contributes to regular electric performance even for slow switch actuator speeds.

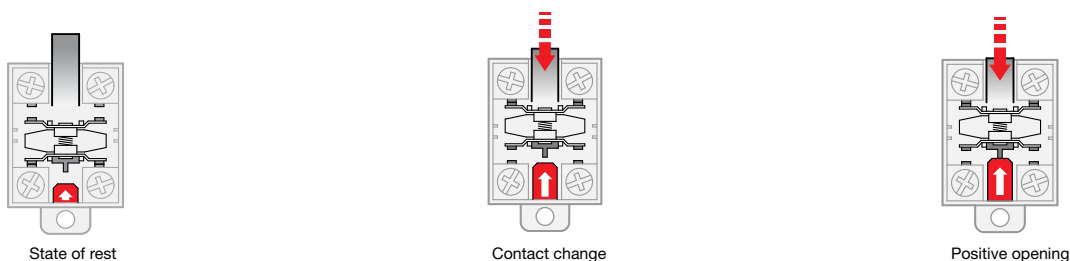

### Slow action

Slow action contacts are characterized by a release position that is the same as the operating position. The switch actuator's speed directly conditions the travel speed of contacts.



### Contact shape according to IEC 947-5-1.

Change-over contact elements with 4 terminals must be indelibly marked with the corresponding **Za** or **Zb** symbol as in the diagrams below.



### Utilization category

AC-15: switching of electromagnetic loads of electromagnets using an alternating current (>72 VA).

DC-13: switching of electromagnets using a direct current.

### Terminals

Limit switches with metal casings must have a terminal, for a protective conductor, that is placed inside the casing very close to the cable inlet and must be indelibly marked.

### Minimum actuation force/torque

The minimum amount of force/torque that is to be applied to the switch actuator to produce a change in contact position.

### Minimum force/torque to achieve positive opening operation

The minimum amount of force/torque that is to be applied to the switch actuator to ensure positive opening operation of the N.C. contact.

# Technical data

## Travel and operation diagrams

9

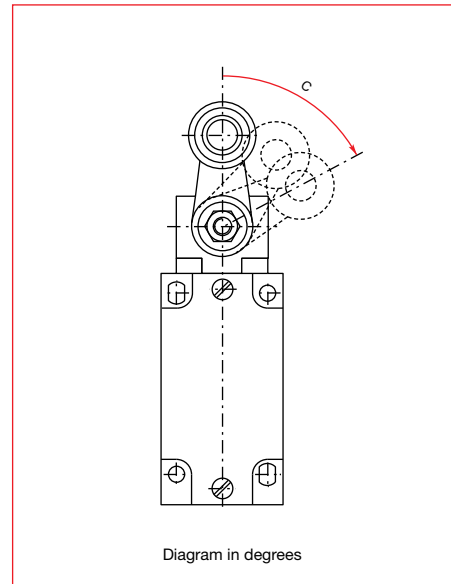
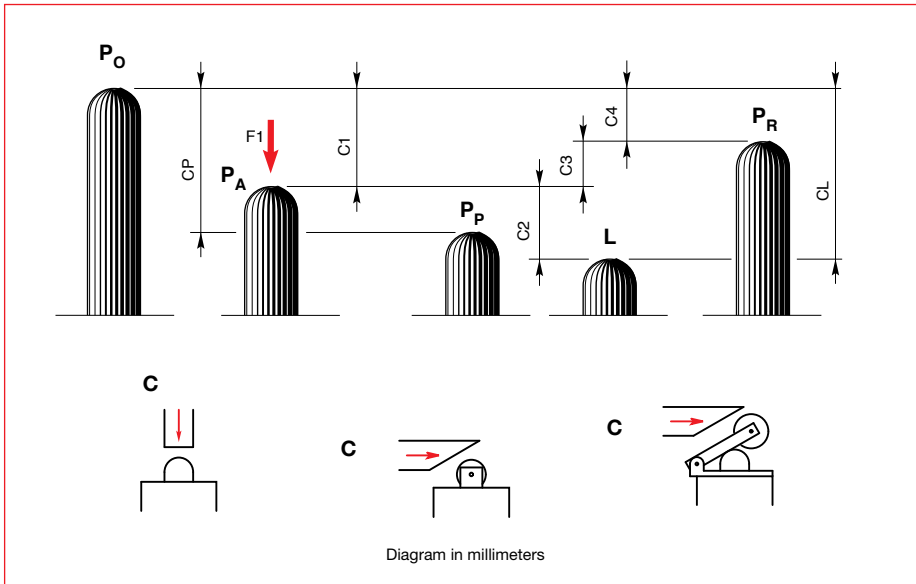

**P<sub>0</sub> Free position**

Position of the switch actuator when no external force is exerted on it.

**P<sub>A</sub> Operating position**

Position of the switch actuator, under the effect of force F<sub>1</sub>, when the contacts leave their initial free position.

**P<sub>P</sub> Positive opening position**

Position of the switch actuator from which positive opening is ensured.

**L Max. travel position**

Maximum acceptable travel position of the switch actuator under the effect of a force F<sub>1</sub>.

**P<sub>R</sub> Release position**

Position of the switch actuator when the contacts return to their initial free position.

**C<sub>1</sub> Pre-travel**

Distance between the free position P<sub>0</sub> and the operating position P<sub>A</sub>.

**C<sub>P</sub> Positive opening travel**

Minimum travel of the switch actuator, from the free position, to ensure positive opening operation of the normally closed contact.

**C<sub>2</sub> Over-travel**

Distance between the operating position P<sub>A</sub> and the max. travel position L.

**C<sub>L</sub> Max. travel**

Distance between the free position P<sub>0</sub> and the max. travel position L.

**C<sub>3</sub> Differential travel (C1-C4)**

Travel difference of the switch actuator between the operating position P<sub>A</sub> and the release position P<sub>R</sub>.

**C<sub>4</sub> Release travel**

Distance between the release position P<sub>R</sub> and the free position P<sub>0</sub>.

**Diagram for snap action contacts:**

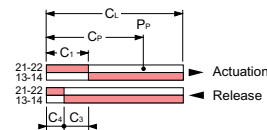

**Diagram for non-overlapping slow action contacts:**

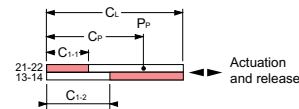

**Note:** for slow action contacts, C<sub>3</sub> = 0, C<sub>1-1</sub> = pre-travel of contact 21-22, C<sub>1-2</sub> = pre-travel of contact 13-14.

**Examples:**

LS45M13B11  
(snap action contacts)

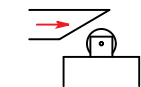

**Diagram in millimeters/cam travel**

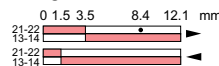

LS45M41B11  
(snap action contacts)

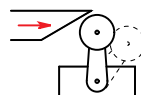

**Diagram in degrees/lever rotation**

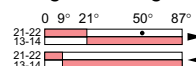

LS45M11D11  
(non-overlapping slow action contacts)

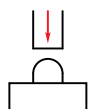

**Diagram in millimeters/plunger travel**

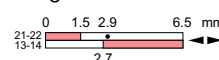

# Technical data

## Utilization precautions

### Plain plunger



### Roller plunger or roller lever

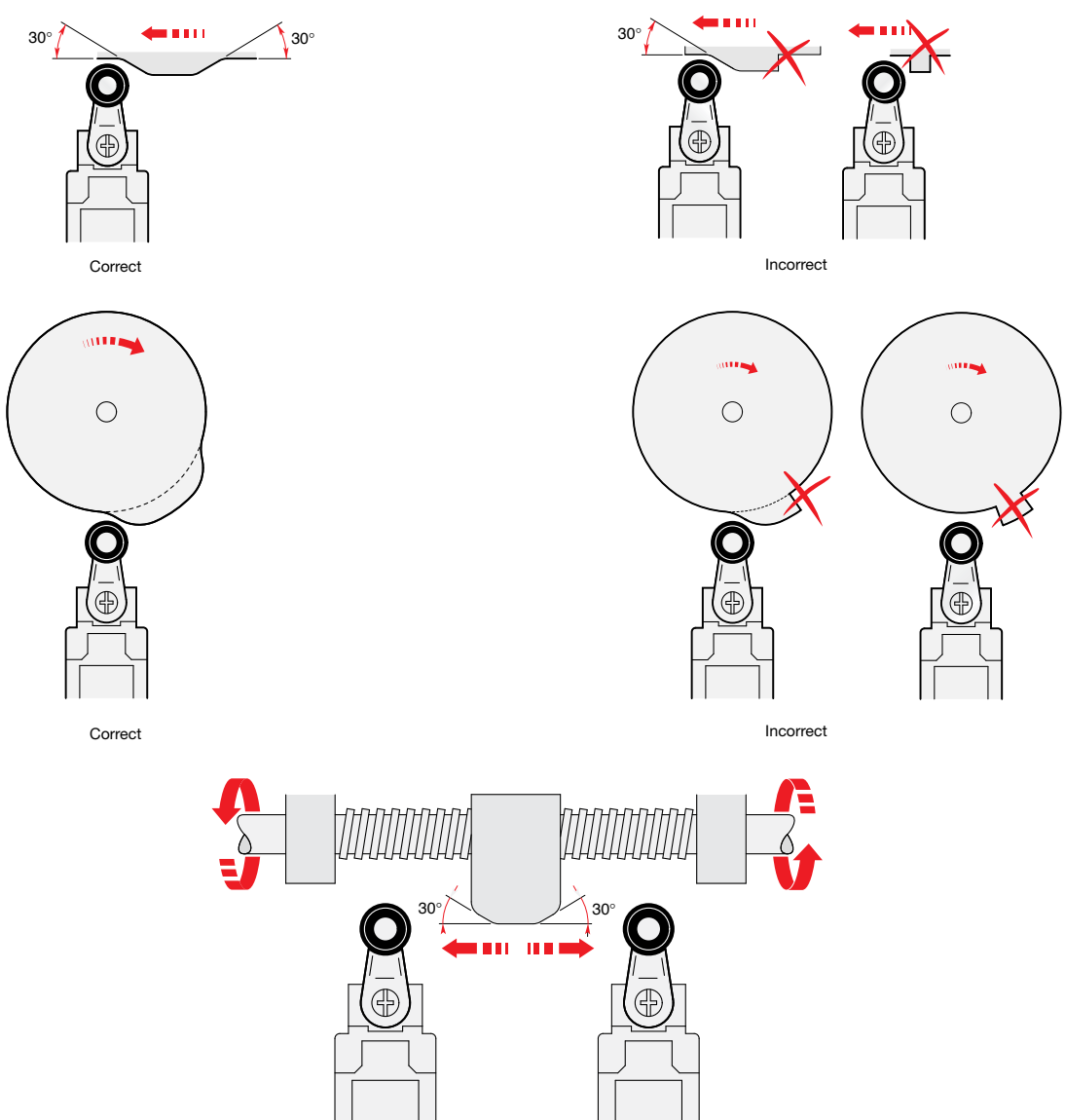

For a relatively slow movement of the switch actuator, a limit switch with a snap action contact block is preferred.

# Technical data EN 50047 standard

The European Committee for Electrotechnical Standardization (CENELEC), which groups together 18 European countries, publishes EN standards.

The present standard defines dimensions and mechanical data for limit switches (30 x 55mm).

## A Shape

Roller lever operating heads

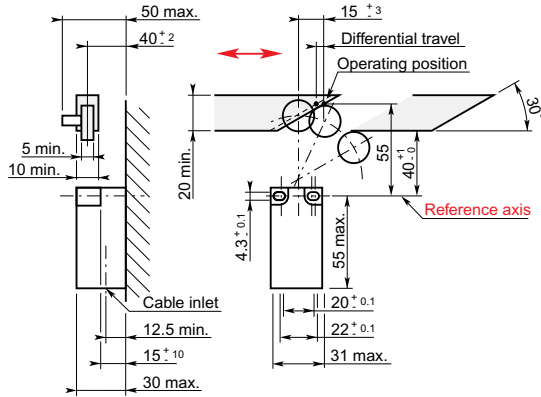

## B Shape

Rounded plunger operating heads

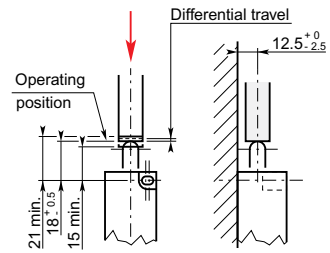

## C Shape

Roller plunger operating heads

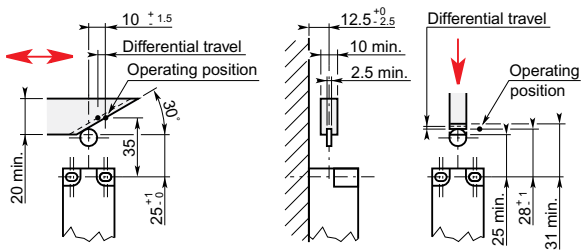

## E Shape

Roller lever operating heads

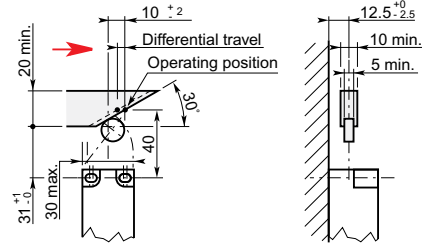

# Technical data EN 50041 standard

The European Committee for Electrotechnical Standardization (CENELEC), which groups together 18 European countries, publishes EN standards.

## A Shape

Roller lever operating heads

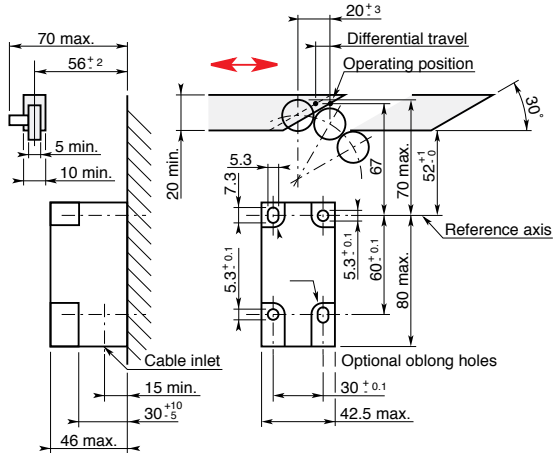

## C Shape

Roller plunger operating heads

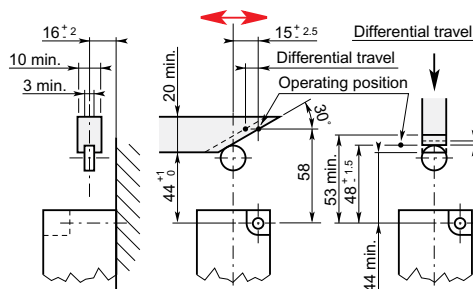

## F Shape

Rounded lateral plunger operating heads

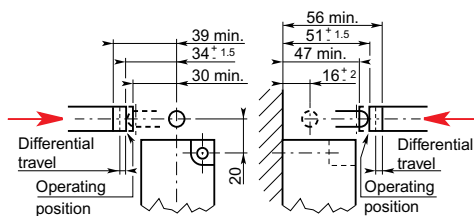

The present standard defines dimensions and mechanical data for limit switches (42.5 x 80 mm).

## B Shape

Rounded plunger operating heads

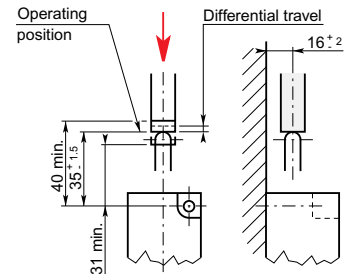

## D Shape

Rod operating heads

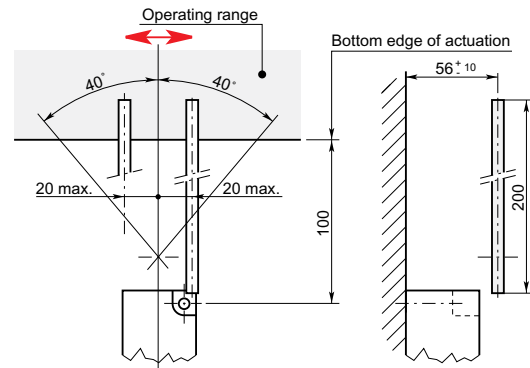

## G Shape

Lateral roller plunger operating heads - Lateral actuation

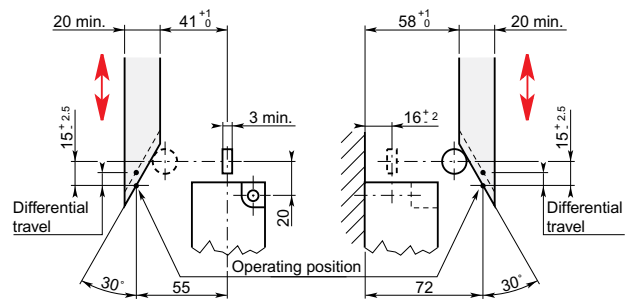

Lateral roller plunger operating heads - Front actuation

