

SattLine

Object-oriented Process Automation

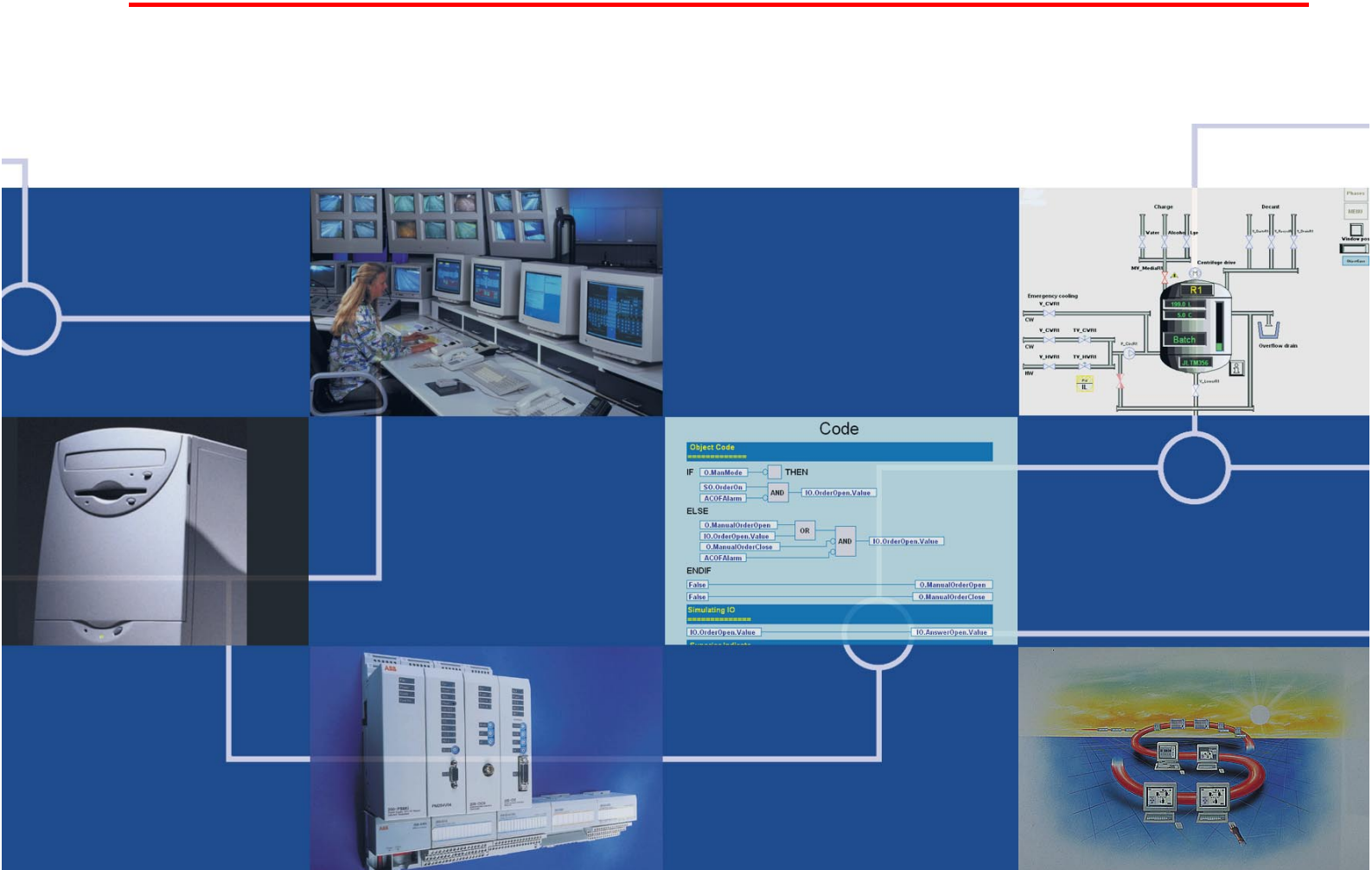

SattLine is an advanced, object oriented, distributed industrial control system.

The system includes WorkStations and Process Controllers communicating with each other over Ethernet.

The SattLine concept realises a fully integrated system. Workstations may be used as both engineering stations and as operator stations.

A high degree of software flexibility and quality is achieved by using an object oriented approach to programming and graphics.

Changes made in the application software are inherited simultaneously, across the plant.

SattLine Workstations are PC stations running Windows 2000 Professional.

Several workstations may view the complete plant simultaneously. Multiple screens may be used to increase the detail available at any single workspace.

Individual workstations may also be configured to offer reduced access to the complete process if required.

The program development environment includes a Source Code Control system. This has revision control and debug mechanisms built-in. Program documentation may be performed via a connected Access database.

SattLine has the following main features:

- Fully object oriented.
- Operator interactions and graphics.
- Information zooming.
- Window based operator interface.
- Sequence control and interlocks.
- PID controllers with autotuner.
- Fuzzy control.
- Alarms and events.
- Data acquisition.
- Batch process support (S88.01).
- Report Generation.
- Connections to OLE/ODBC.
- ES/ER to comply with FDA 21CFR Port 11 regulations.

System Configuration

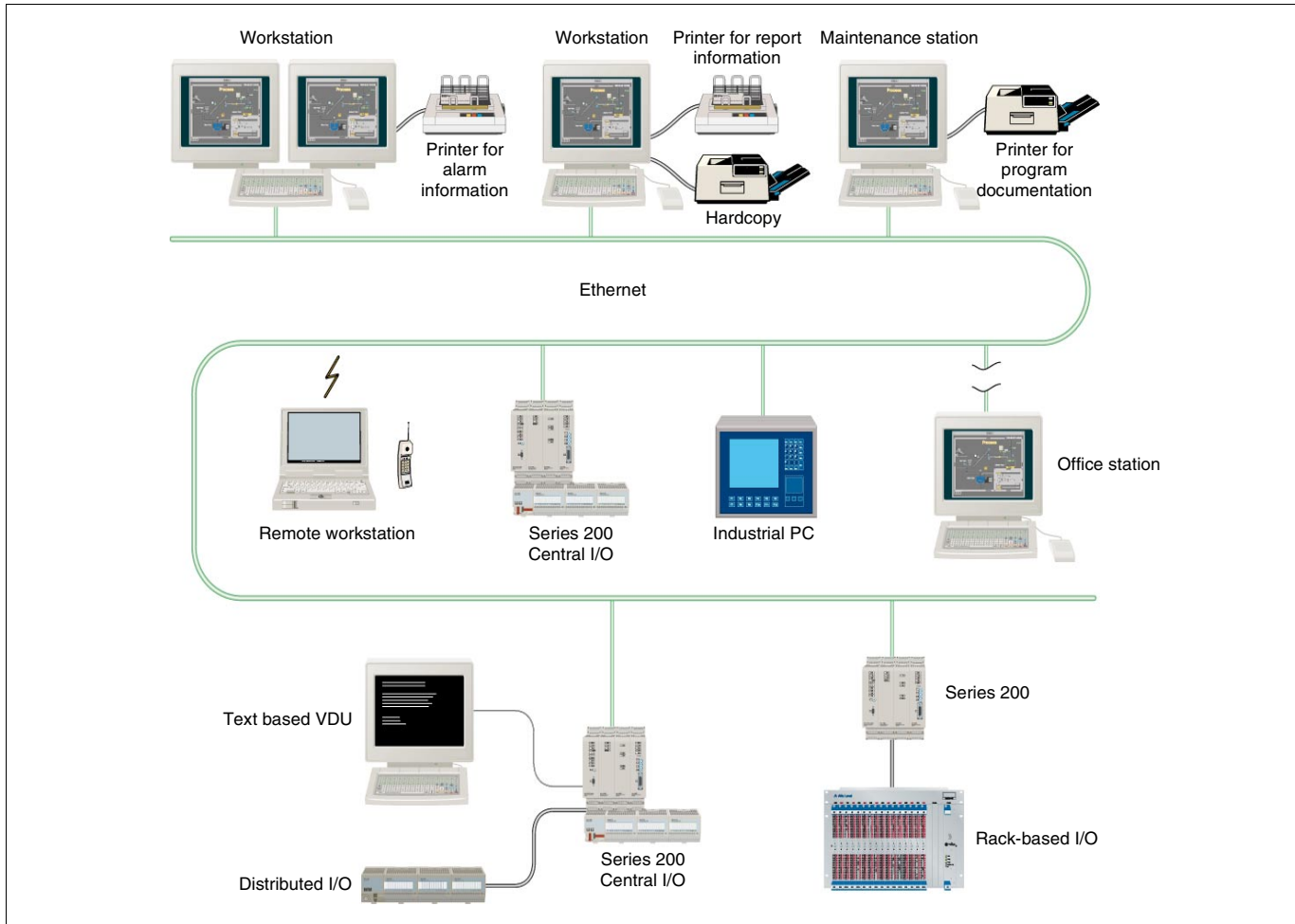

Object-oriented Process Automation

A common control language is used throughout all components of the system to cover the various needs of a control application.

SattLine includes the process graphics, operator interaction and program code for calculations and control in one and the same object. The objects, called Module types, may be saved in libraries.

Programs consist of a hierarchy of such objects which are able to correspond to physical objects in the plant or process functions.

In a large installation, there would normally be several more or less independent process units, controlled by systems connected on the same network.

It is possible to divide the execution of a program between several controllers. This is desirable if the process segment I/O count is too large to be controlled from a single controller or there are demands for faster execution.

Process objects may be built to include the program code, visual representation, interaction, data acquisition and communication etc. These objects are stored in libraries and are thus made reusable in both the current and future applications.

Window Techniques

SattLine may implement several types of window. Windows containing process overview or detail may be created on-line by the operator. Process objects may be built to contain interactions which create pop-up windows for control panels or other process views.

The information zoom facility makes it possible to organise and view process information in various levels of detail.

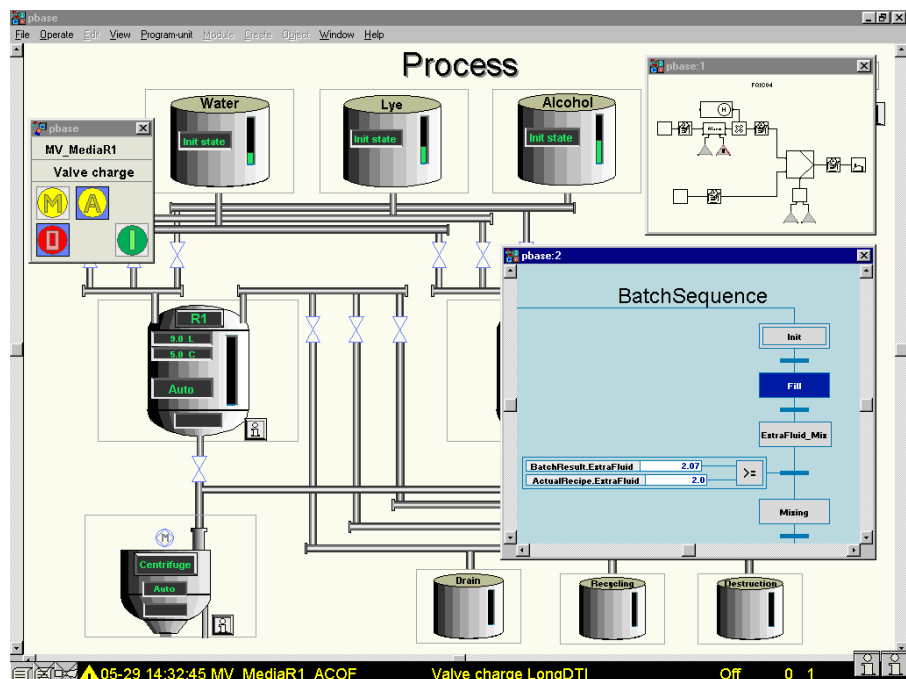

A SattLine process window

Functions

Alarms and Events

Alarms may be generated in both the workstations and the controllers. The alarm list in the workstation has extensive filter and sorting mechanisms which allow the operator to sort and select which groups of alarms are viewed. Several alarm lists may be configured. Alarms may be placed in classes and each associated with a particular severity.

An *EventLog* is used to save all alarms and events on a hard drive over a certain period.

Alarms can be inhibited and presented in the list of inhibited alarms.

Historical Data Handling

Process variables, Alarms, Operator interactions etc., may be stored as historical data. Such data may be stored as a *SattLine Journal* or else in an external database via ODBC.

Historical data may be presented as a textual report based on time, a Batch related report, or as historical graphs. Graphics may be incorporated into text reports.

A sophisticated historical data display is available which may be used to view data from one or more journals simultaneously. The time axis may be made absolute or relative by operators.

Batch related information such as recipes, and batch events may also be stored in *Journals* or in an external database.

Reports

The report library can be used to create program controlled reports including graphics, e.g. trend curves.

Batch Handling

Using the *SattBatch* library (compliant with ISA S88.01) gives the user a high level access to batch control. The library can control all batch processes from single paths and products to multi purpose plants. Phases and operations are easily created.

The recipe can describe both a unit recipe and a main recipe for a complete process cell. A graphical recipe editor is used to create the recipes (Revision control for recipes may be implemented). The same display is used to follow the execution of the batch on-line.

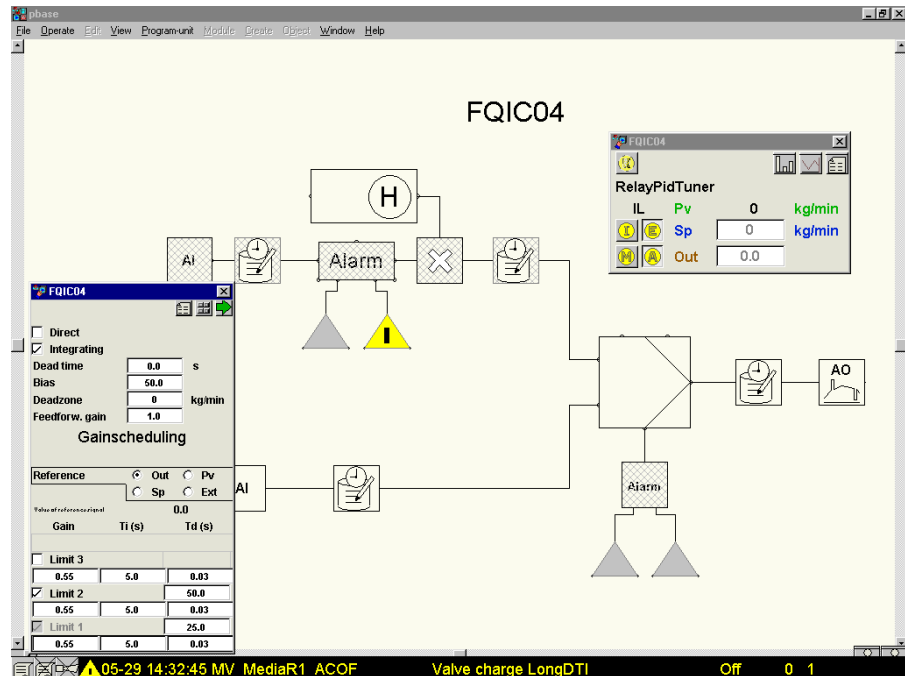

Control Loops

Control Loops

A wide range of pre-defined modules are available, e.g. PID, filters, ramps, taps and splitters. These modules are graphically connected to each other to create a complete control loop function.

The control loop includes functions for autotuning (automatic setting of control parameters) and gain scheduling with different parameter set-up for different control range. All modules have *back-tracking* which enables bumpless transfer between auto and manual control.

A function in the PID gives an alarm if oscillations, due to stiction (static friction) in control valves, is detected in the process. To minimize the oscillations a *Stiction compensation* function can be enabled at the analogue output module.

All modules have a built-in user interface, e.g. the PID module has windows for parameter set-up, variable trend curve display and bar graph representation of setpoint etc.

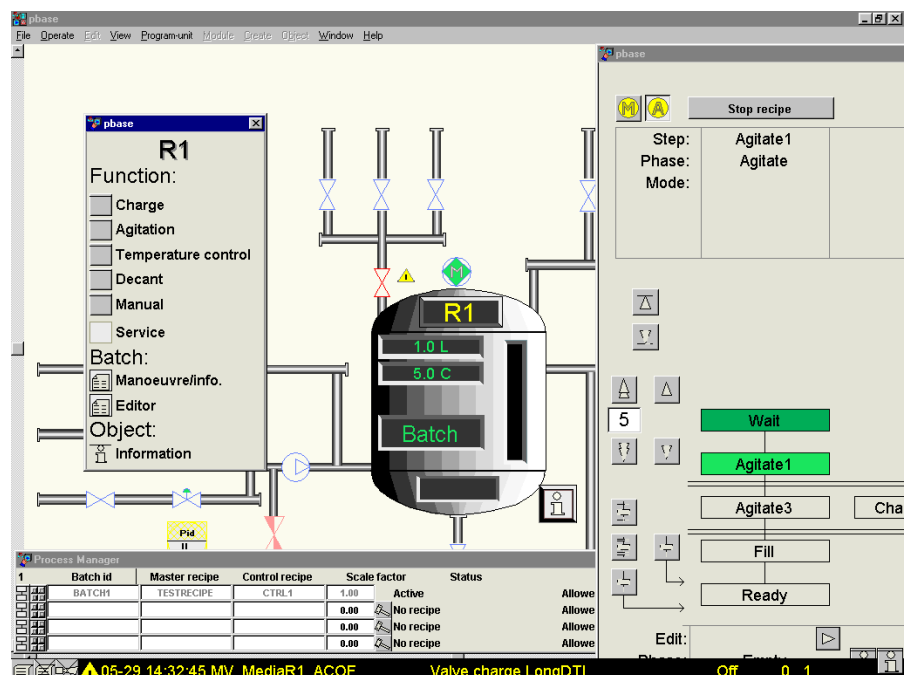

Batch handling

Programming Program Development

A *Source Code Control System* is a part of the program development environment. Development in workgroups is utilized by source code reservation and distribution. A ChangeLog is saved together with the library or program, giving the user full control of development changes.

Programming Methods

A common control language is used across all components of the system. The language is tailored to the need of advanced process control. A program is built of many objects, in a hierarchical structure, each object corresponds to a real-world object or function.

Objects may contain graphics (for visual representation), operator dialogues and code for control and calculations.

A programmer builds an object as a module whose type may be stored in libraries. Such library modules may be reused throughout the application. A library of module types may easily be used in future applications.

The behaviour of a module is defined by equation blocks and sequential flow charts. A module may also contain instances of other modules. The modules interact with their surroundings by parameters connected to local variables. Conditional evaluation of equations may be performed using IF.. statements or by sequential flow charts.

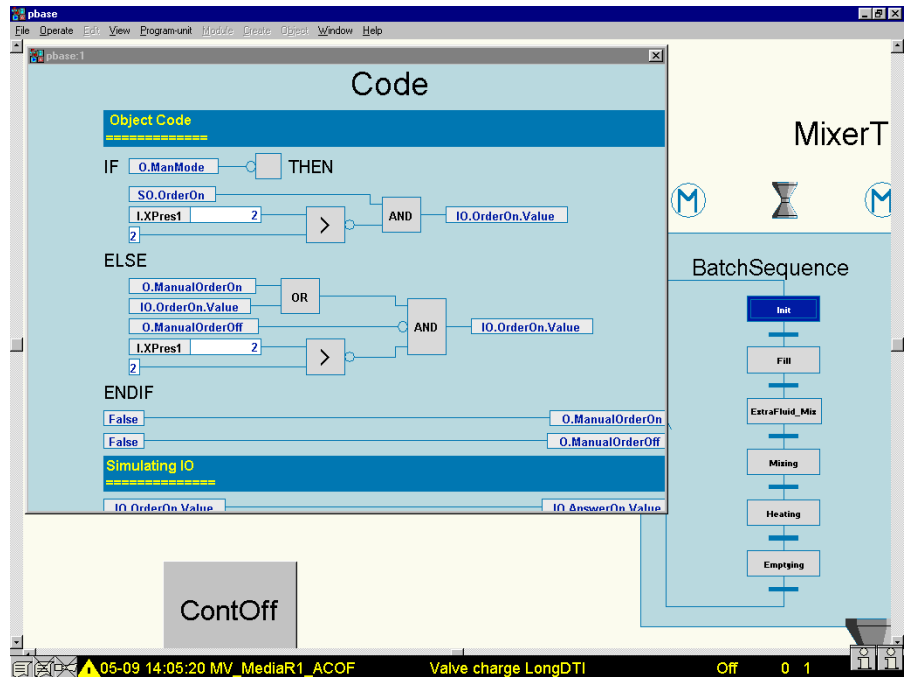

Programming methods

Openness

Several software gateways are available to provide communication to the Windows environment. The ODBC-MMS gateway can be used to store data directly from a controller or workstation into a database. OLE-MMS gateways is used for transferring data from SattLine by use of Microsoft OLE links.

External Windows programs can be activated from the workstation by the use of the *SystemCommand* feature.

Documentation

The system provides a wide range of tools to make program documentation. Objects can be documented, either the object definition itself, or within its context. I/O list are easy to generate.

Documentation can also be generated through an *Access* database, giving very flexible and useful documentation.

Manuals online

All SattLine manuals and data sheets are, besides the printed ones, available online for reading in PDF format.

Microsoft Access - [Pid : Report]

Pid
12-maj-97

R2_Water RelayPidFilter

Path: Fase:TempFas:TempStyCont2.Pid
Sp: process1.R2.Fase:TempFas:Bovinda:Temp
Pv: TempFas:AngStyCont2<FilterRea11.Out-Pid.Pv>
C: TempFas:AngStyCont2<Pid.C.Ao.Inp>

Gain: 4.43 Td: 27.0
Bias: 50.0 Dr: 0.0
Integral: True Direct: False
Pv unit: Pv max: 100.0
C unit: C max: 100.0

ProgramUnit: pmcprocess System: 3com_661.F51

R2_Steam RelayPidFilter

Path: Fase:TempFas:AngStyCont2.Pid
Sp: process1.R2.Fase:TempFas:Bovinda:Temp
Pv: TempFas:AngStyCont2<FilterRea11.Out-Pid.Pv>
C: TempFas:AngStyCont2<Pid.C.Ao.Inp>

Gain: 4.43 Td: 27.0
Bias: 50.0 Dr: 0.0
Integral: True Direct: False
Pv unit: Pv max: 100.0
C unit: C max: 100.0

ProgramUnit: pmcprocess System: 3com_661.F51

Documentation

Microsoft Access - [Iocross : Report]

IO crossreference
12-maj-97

Name	Read/Write	in system	in scangroup	in equation
IO_SEPI.R1.VentIHMediaIn.Open				
R	3	com_661.F51	SLCN orm al	Screen.process1.R1.VentIHMediaIn.SOCcode
R	3	com_661.F51	SLCN orm al	Screen.process1.R1.VentIHMediaIn.SOCcode
IO_SEPI.R1.VentIHMediaIn.Closed				
R	3	com_661.F51	SLCN orm al	Screen.process1.R1.VentIHMediaIn.SOCcode
R	3	com_661.F51	SLCN orm al	Screen.process1.R1.VentIHMediaIn.SOCcode
IO_SEPI.R1.VentIHMediaIn.LocalMode				
R	3	com_661.F51	SLCN orm al	Screen.process1.R1.VentIHMediaIn.SOCcode
IO_SEPI.R1.VentIHMediaIn.OrderOpen				
W	3	com_661.F51	SLCN orm al	Screen.process1.R1.VentIHMediaIn.Ccode
IO_SEPI.R1.VentIHMediaIn.OrderClose				
W	3	com_661.F51	SLCN orm al	Screen.process1.R1.VentIHMediaIn.Ccode

Document program item - [Object : Report]

Object	Program	Module type	Module name	Motor Type
1997-05-20	demo	sldemo	MotorType3	
	System: Rem Sys00A024661F51	Scan Group: Normal		
	Path: P_O.Pr.MixerTank.Mixer9			

IO in	In	Value	Parameter	Out	IO
	Base Picture: Object Name Mixer9	Mixer9	Name		
	Base Picture: In Plant: Process MixerTank Mixer9	Mixer9	Description		
	Rem Sys00A024661F51.0.10		IO		
			IO Fault		
			IO_OrderOn		
			S0		
	P_P_O.Pr.MixerTank.Mixer9		IO_OrderOn		
	P_P_O.Pr.MixerTank.BatchSequence		S0_OrderOn		
	P_P_O.Pr.MixerTank.BatchSequence		S0_OrderOn		
	Base Picture: In Plant: Process MixerTank.LS11		LevelBlock		
	Base Picture: Event Class: Process		Alarm Class		
		61	Alarm Tag Overload		
			Mixer_M9OVER-		
			Mixer_M9RUT-		
			Mixer_M9RUT/Pre-		
			Alarm Tag/Pre		
			Mixer_M9RUT/Pre-		
			Alarm Tag/Pre		
			F19-		
			SelectButton		

Software

Program Templates

Start package

Templates with a start-up environment including modules for process objects, alarms, events and trend curves. The *Start Package* gives the structure and the basics for construction of applications.

Standard Library Software

- **Basic Libraries** includes standard icons, buttons and panels.
- **I/O Library** includes modules for configuration of control systems and I/O's, both local and remote. The library also contains modules for the configuration of other types of I/O, e.g. SattTop I/O and Altop I/O.
- **Function Libraries** includes Function modules (e.g. PID controllers with autotuner, control loop templates), modules for data acquisition, event and alarm handling, VT100 terminal handling, valve feedback control (ACOF) and time control (TCC).
- **Communication Libraries** includes modules for application controlled communication e.g. COMLI, SattBus, Siemens 3964R (Master)*, and MMS. The library also contains modules to be used for writing application specific protocols, e.g. barcode readers or scales.

* Requires an additional license

Optional Library Software*

- **Batch Library*** includes modules for batch handling with ISA S88.01-1995 based batch control.
- **SQL Library*** includes modules for database communication, using ODBC.
- **Fuzzy Controller Library*** includes fuzzy logic controller.

Additional Utility Software*

- OLE MMS Gateway*.
- ODBC MMS Gateway*.
- OPC SattLine Server for data access (OPC = OLE for Process Control)*.

Hardware

Workstations

The SattLine workstations are available at three different levels: *Mini*, *midi* and *maxi*. These can be used for programming, maintenance, controlling and management.

For programming only, a *programming/development license* is available. The *SattLine viewer license* can be used at the office for temporary process control.

The level of access is restricted by personal passwords. The workstations are based on standard hardware (PC), using Windows 2000 Professional as operating system. Other Windows functions can be restricted in order to enable a safe environment for the user.

Control System

The control system consists of a central system including CPU and communication modules. Connected to the central system is a remote or centralized I/O.

A wide range of compatible CPU's are available.

For technical data information and order codes on the various control systems, see separate data sheets for the Series 200.

Redundancy

SattLine supports a redundant MMS network, on the workstations and in the controllers.

The workstations can be setup for redundant use. All workstations within the plant might have the same SattLine programs loaded, hence giving all stations access to all parts of the process.

Communication

The workstations and control systems communicate on a standard Ethernet network using the MMS protocol. Standard Ethernet cables are used, e.g. fibre and coax. For dialled connections, Windows 2000 Professional Dial-up connections or SattLink can be used.

For distributed I/O, the fieldbus ControlNet is used.

For external communication various protocols available, see table on last page.

Control System Overview

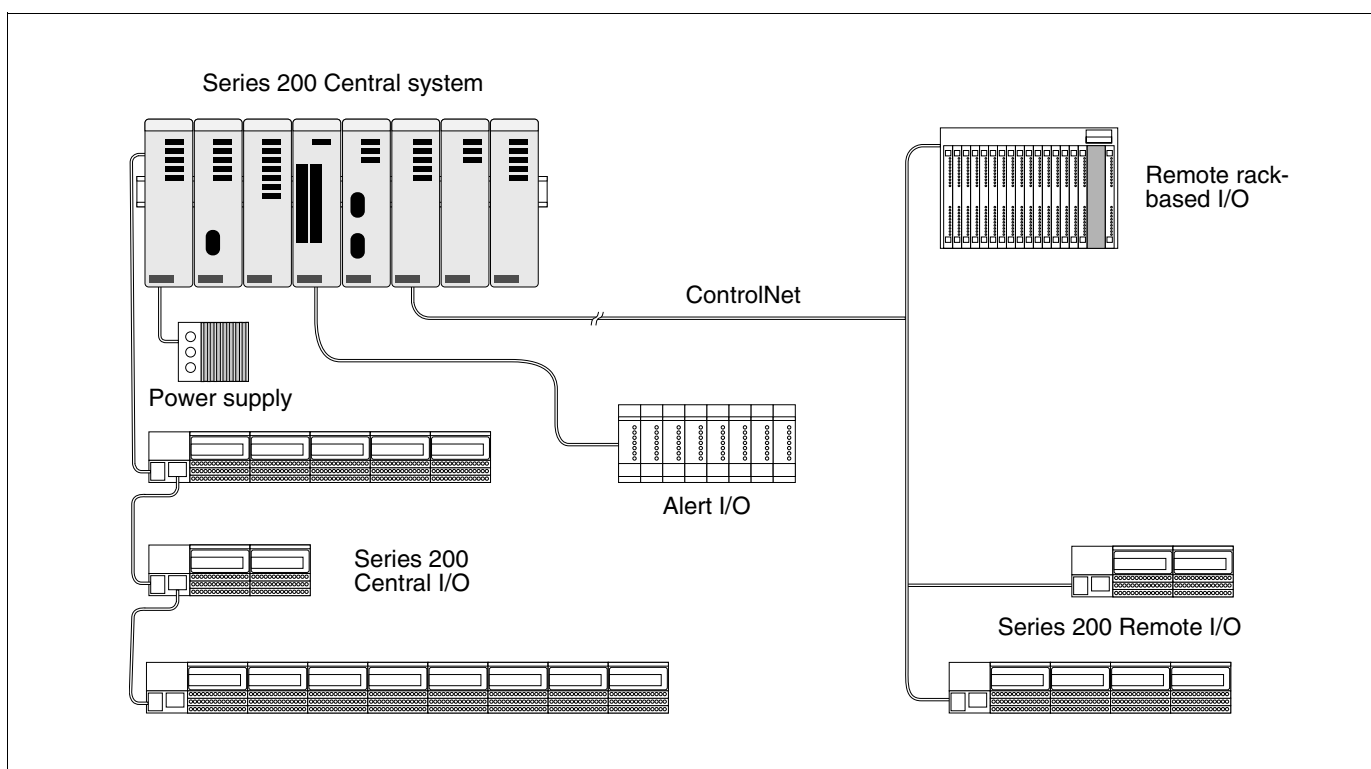

Technical Data for SattLine version 2.3

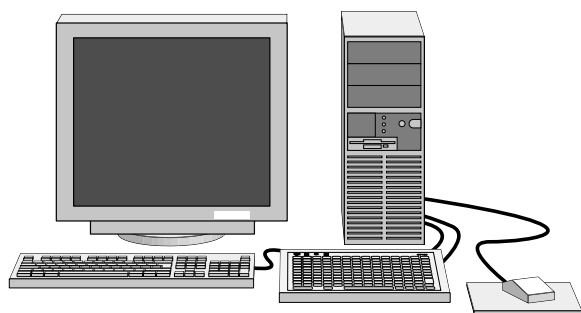

Operating system	Windows 2000 Professional.
Hardware	A PC that complies with <i>Windows 2000 Professional Compatibility List</i> based upon Intel processors, except the Celeron type. No support for multiple processors.
Back-up	Removable mass storage (e.g. SyQuest or DAT).
Graphical board	1024 x 768 pixels and 256 colours min.
Communication board	An Ethernet board is required. A second board can be used for redundancy.
Serial ports	See <i>Windows 2000 Professional Compatibility List</i> for hardware.
Printers	Alarm printers must be line oriented. Printers for reports and hardcopy must comply with the <i>Windows 2000 Professional Compatibility List</i> .
Operator's keyboard	Standard PC keyboard or a configurable IP65/IP54 keyboard from ABB.
Pointing device	Three-button mouse is recommended.
Other devices	The system software is distributed on CD-ROM only, hence a CD drive is required.

Communication Protocols

	PC	Controller
MMS on reduced OSI stack	X	X
MMS on TCP/IP (reduced OSI stack)	X	X
SattBus ¹	X	X
SattBus on TCP/IP	X	
COMLI	X	X
Siemens 3964R Master ²	X	X
Profibus DP		X
ControlNet		X
MAP/OSI (MMS on full OSI stack) ²	X	
SINEC/H1 MAP ²	X	
SQL client	X	X

¹ Requires additional hardware.

² Requires an additional license.

Microsoft, Window 2000 Professional, Access and OLE are registered trademarks of the Microsoft Corporation.



Automation Technology Products

SE-721 59 Västerås
Sweden
Phone: 46 (0) 21342000
Fax: 46 (0) 21137845
www.abb.com/processautomation
email: processautomation@se.abb.com

Automation Technology Products

29801 Euclid Avenue
Wickliffe, Ohio 44092, USA
Phone: 1 440 585 8500
Fax: 1 440 585 8756
www.abb.com/processautomation
email: industrialsolutions@us.abb.com

Automation Technology Products

Dudenstrasse 44-46
D-68167, Mannheim, Germany
Phone: 49 (0) 1805 266776
Telefax: 49 (0) 1805 776329
www.abb.de/processautomation
email: marketing.control-products@de.abb.com

3BSE 025 465 R101 Rev B 0111

Copyright © 2001 by ABB Automation Technology Products. All rights to trademarks reside with their respective owners. Specifications subject to change without notice. Pictures, schematics and other graphics contained herein are published for illustration purposes only and do not represent product configurations or functionality. User documentation accompanying the product is the exclusive source for functionality descriptions.