

1SFC170015M0201 EN, REV B*

Current Sensing Unit

Installation and maintenance guide



* Appendix for Arc Guard System™ – TVOC-2 Installation and maintenance guide EN

Safety

Warning and information

This chapter describes warning and information signs used in this manual, which the user should pay attention to.

- The installation shall be performed by authorized personnel only.
- The manual shall always be read through before performing any tasks.

Usage of warnings and notes

There are two types of safety instructions throughout this manual: warnings and notes. Warnings caution you about conditions which can result in serious injury or death and/or damage to the equipment, and advise on how to avoid the danger. Notes draw attention to a particular condition or fact, or give information on a subject. The warning symbols are used as follows:



CAUTION

Caution icon indicates the presence of a hazard which could result in personal injury.



WARNING

Warning icon indicates the presence of a hazard which could result in damage to equipment or property.



Electrostatic sensitive devices warning

Tells that electrostatic discharge is needed to not damage the equipment.



INFORMATION

Information sign alerts the reader to pertinent facts and conditions.



Electrostatic sensitive devices warning

The printed circuit boards contain components sensitive to electrostatic discharge. Wear a grounding wrist band when handling the boards. Do not touch the boards unnecessarily. Use grounding strip:

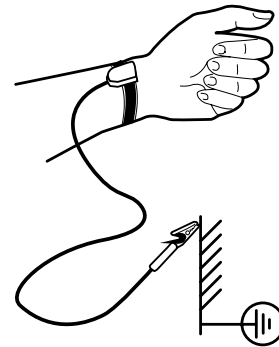

Personal safety



Service and repair should be performed by authorized personnel only. Note that unauthorized repair affects safety and warranty.

ABB personell have to, as a minimum, follow the ABB CISE 15.4 instructions.

Current Sensing Unit

Installation and maintenance guide

6	1.1 Introduction
6	1.2 Mounting of the component
7	1.3 Electrical installation of CSU
8	1.4 Connection of optical fibre cables and detectors
8	1.5 Settings for operation
9	1.6 Control
10	1.7 Diagrams and layouts

1.1 Introduction

This is a appendix to **Arc Guard System™, TVOC-2 Installation and maintenance guide**, which shows operation connections between the **TVOC-2** and the **Current Sensing Unit (CSU)**.

This appendix shows connection of Fibre cables and Detectors, how to control, diagrams and layouts.



CAUTION

Risk of Electric Shock. Do not remove any current range bridge connection when current circuits are live!



WARNING

Safe working methods must be used to prevent injuries. The safety equipment must not be disengaged, bypassed or in any other way modified so that the safety effect ceases.



INFORMATION

For further information about installation and maintenance for the Arc Guard System, see manual;

Arc Guard System™, TVOC-2 Installation and maintenance guide 1SFC1700011M0201

1.2 Mounting of the component

This chapter describes how to mount the TVOC-2 and the CSU. For mounting details of the TVOC-2 and the CSU, see: **Chapter 4, Mounting** on page 24 in **Arc Guard System™, TVOC-2 Installation and maintenance guide 1SFC1700011M0201**.

1. Mount the Units

The TVOC-2 and the CSU should be mounted according to **figure 1**. The flange opening shall be facing downwards, inside a cubicle, separately on a wall or stand.

- 1 Loosen 2x screws on the CSU box.
- 2 Open the hatch of the CSU box.

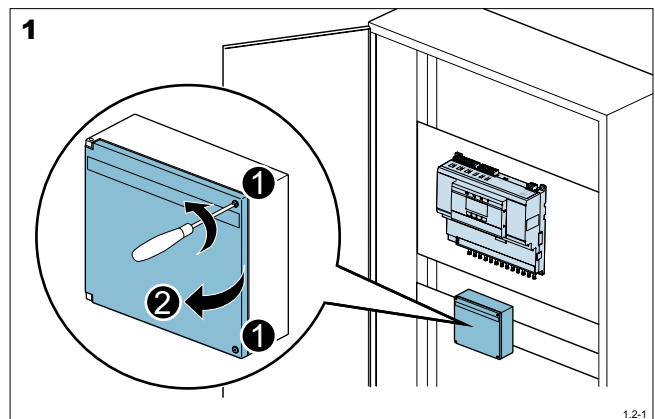

2. Earth the component

- 1 Earth the component according to **figure 2**.

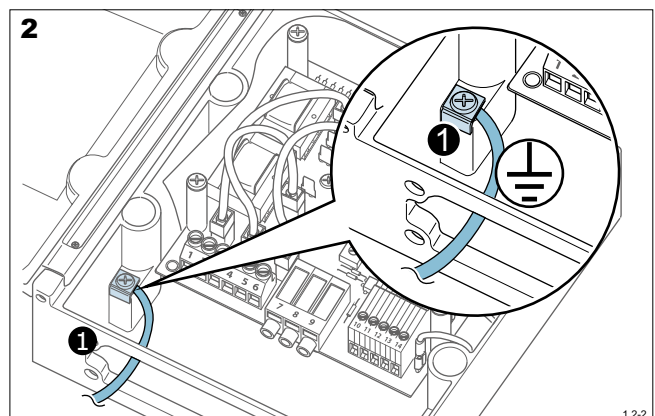

1.3 Electrical Installation of CSU

This chapter describes the electrical installation of the CSU. For Wiring diagrams and layouts, see chapter 1.7 Diagrams and layouts.



CAUTION

Risk of Electric Shock. Do not remove any current range bridge connection when current circuits are live!



WARNING

Safe working methods must be used to prevent injuries. The safety equipment must not be disengaged, bypassed or in any other way modified so that the safety effect ceases.

3. Connect supply voltage

① Connect the supply voltage to terminal 10...14. Select the terminals according to desired voltage, See 1.7.2 Simplified block diagram.

4. Connect the external current transformers

① Connect the current-circuits from the external current transformers to terminal 1...6.

Single-, two- or three-phase connection is possible, but single-phase connection results in a somewhat longer function time.

5. Connect one side of current-circuit to earth

① One side of each current-circuit should be connected to earth. ② By EMC-reasons this is best done by earthing of the terminals 2, 4 and 6 inside the enclosure.

6. Connect the Current transformers internal

① The internal connection in the CSU is selected according to which secondary rating the chosen transformers have. See table below.

Table 5

Secondary rating of transformers	Connection Id
1A	X24-X17, X25-X20, X26-X23
2A	X24-X16, X25-X19, X26-X22
5A	X24-X15, X25-X18, X26-X21

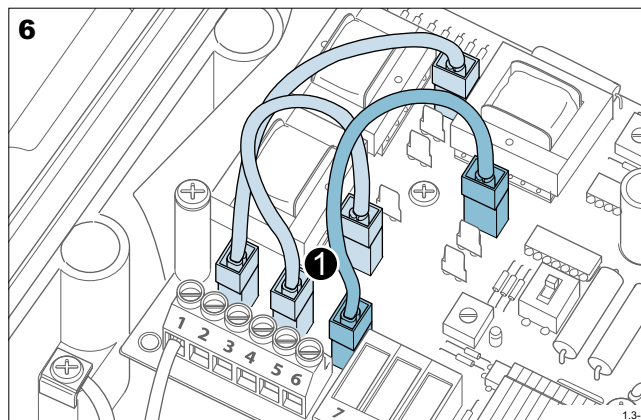
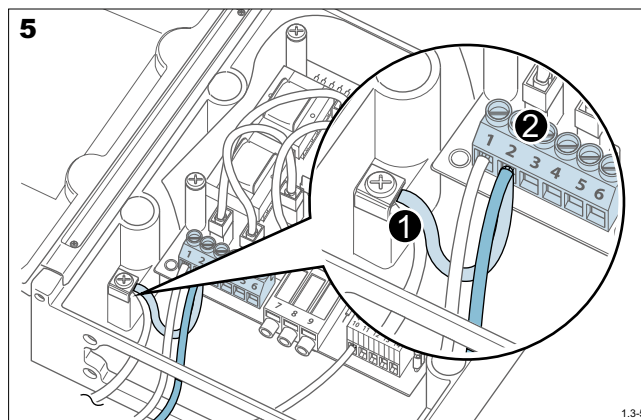
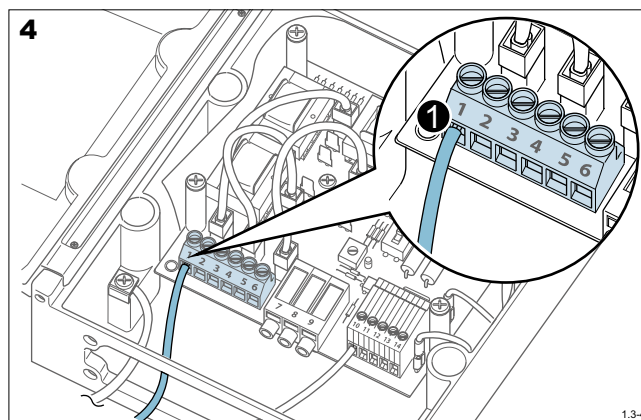
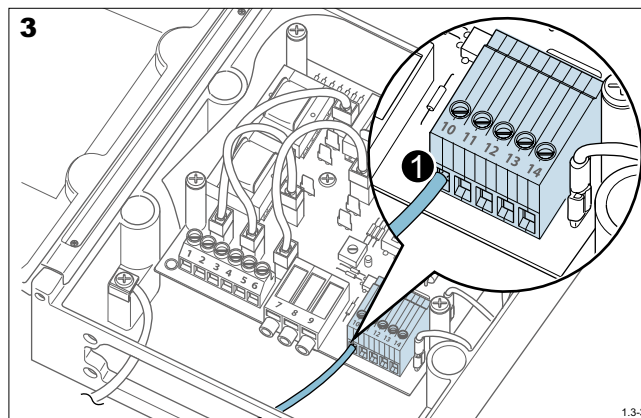

1.4 Connection of Optical Fibre Cables and Detectors

General

Before the detectors can be connected to the component the protective covers on the input terminals must be removed. Please note that unused optical inputs must have their protective plugs inserted, to avoid incorrect tripping signals coming from them.

When connecting the detectors to the component the end sleeve of the optical fibre is pressed to the bottom of the connection terminal. Please check that it can not be removed easily by gently pulling the optical fibre cable.

7. Connect the detectors to the Arc Monitor

① Remove the protection plug. ② Connect the detector cable to the detector inputs at the lower right side of the Arc Monitor.

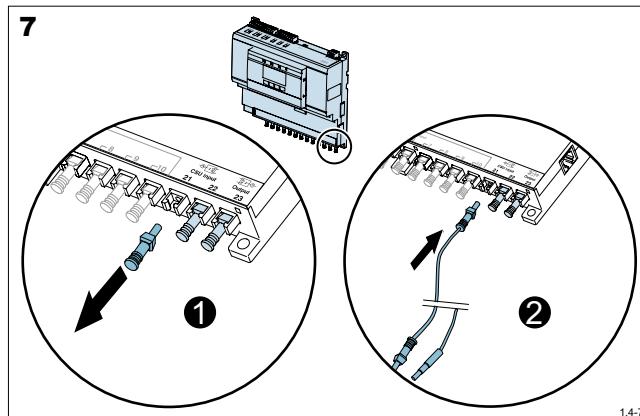

8. Connect the TVOC-2 to the CSU

① Connect a optical fibre cable to 21 or 22 in the Arc Monitor. ② Connector the other end of the fibre cable to 7 or 8 in the Current Sensing Unit.

Connect outsignal from the CSU

If more than one Current Sensing Unit is used, the optical fibre cables are connected from output 7 or 8 to input 9 of the next Current Sensing Unit so that the Current Sensing Units are connected in series.

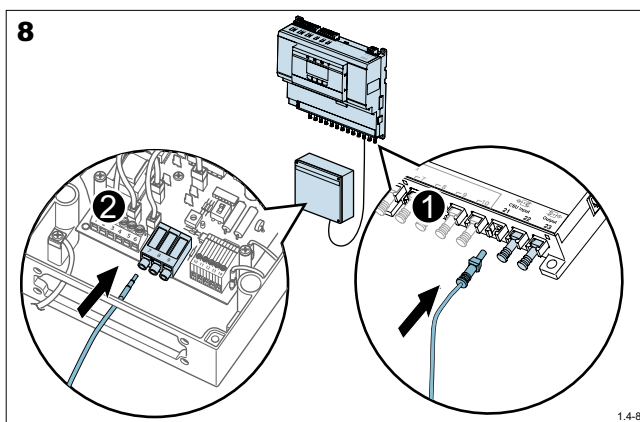

1.5 Settings for Operation

9. Test or Operational position

The CSU can be switched to Test position or Operational position by turning the S1 Switch.

Switch S1 ① in figure 9

Position 1: Test

Position 2: Operation

Switch input 9 on or off

Input 9 of the CSU can be switched to on or off position by turning the S1 Switch.

Switch S2 ② in figure 9

Position 1: When input terminal 9 is not used.

Position 2: When input terminal 9 is used.

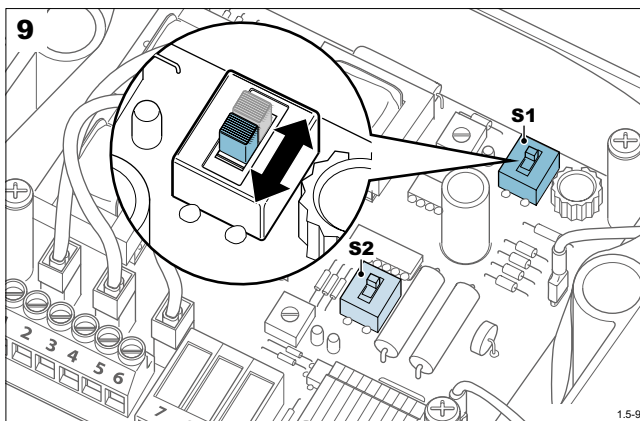

10. Set the nominal level with Potentiometer R21

The nominal overcurrent level is set with the **Potentiometer R21**

The overcurrent level should be set as low as possible. Adjustment must be done at max load current. The potentiometer is turned clockwise until both the yellow LED V27 ① and the green LED V29 ② are lit. It should then be turned back slightly until the yellow LED is switched off. With this setting the current sensing unit will indicate an overcurrent at a level of approx. 140% of the max set current level.

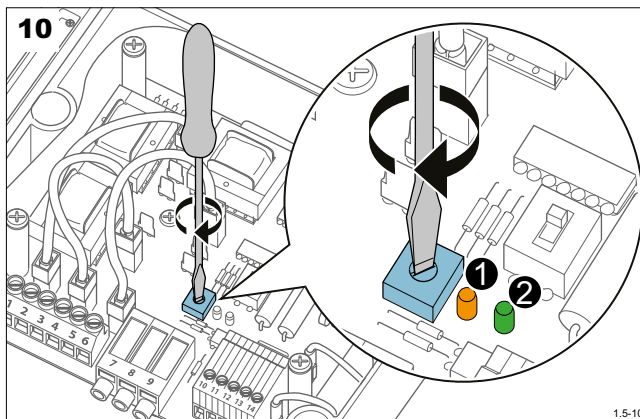

1.6 Control

Perform this test after installation, before using the unit.
 Switch on the supply voltage.

Switch S1 to position 1, (the test position).

A red lit LED, V22, indicates that S1 is in test position.

11. Control the Overcurrent

An overcurrent is simulated by turning the potentiometer R29 clockwise until both the yellow, V27, and the green, V29, LEDs are switched off.
 A fault is simulated, and it should be checked that the circuit breaker trips.

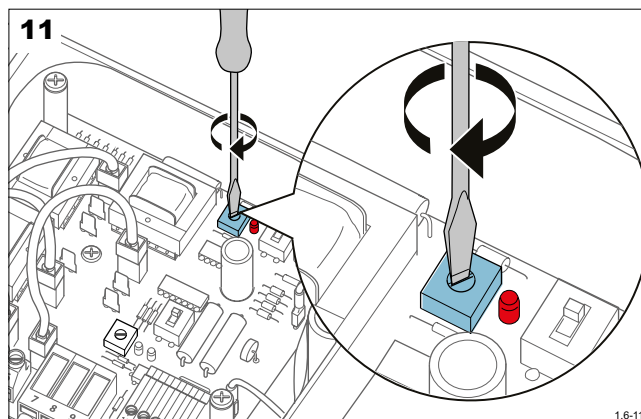

12. Control the Normal current

A normal current is simulated by turning the potentiometer R29 counter clockwise so that both the yellow LED and the green LED are lit.
 A fault is simulated again, in the same way as above, and it should be checked that the circuit-breaker does NOT trip.

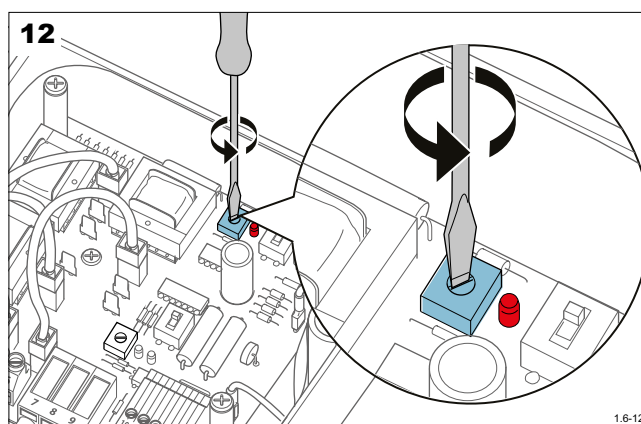

Resetting to NORMAL RUN condition is done by setting switch S1 in the Current Sensing Unit to position 2.
 (The red LED V22 is switched off.)

1.6.1 Test when in use



WARNING

Since the breaking capacity of the disconnectable terminal blocks are very low, they must not be opened when there is current flowing in the circuit.

To enable a test to be done when the Arc Monitor is in use, the trip circuit can be disconnected by opening the inputs 21 ① and 22 ②.

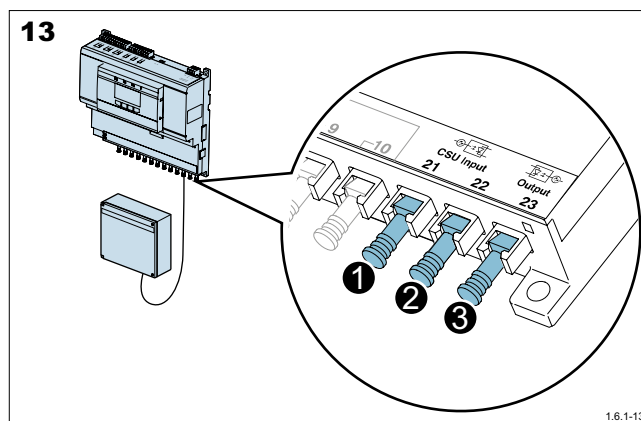

DO NOT FORGET TO RECONNECT THE TERMINALS 21 ② AND 23 ③ AFTER THE TEST.

A control of the function is recommended after every arc fault and should also be carried out regularly, e.g. once a year. This applies to all units.



INFORMATION

If the dip switches on the TVOC-2 are configured to have a CSU installed and the CSU cable is disconnected, a fault indication will appear. Fault indication will disappear when reconnecting the CSU cable to the TVOC-2.

1.7 Diagrams and layouts

1.7.1 Current Sensing Unit

Table 5

Current Sensing Unit ①	
	From another Current Sensing Unit
V22	Red LED, switched on when S1 is in test mode
S1	Test switch Position 1: Test Position 2: Operation
R29	Potentiometer for simulating a test current
V29	Green LED switched on for normal current and switched off for overcurrent
R21	Potentiometer for overcurrent setting
V27	Yellow LED, switched off at approx. 70% of over-current level
S2	Operation condition switch Position 1: Input 9 is not used Position 2: Input 9 is used
X15	Terminal pins for
X26	Choice of current range

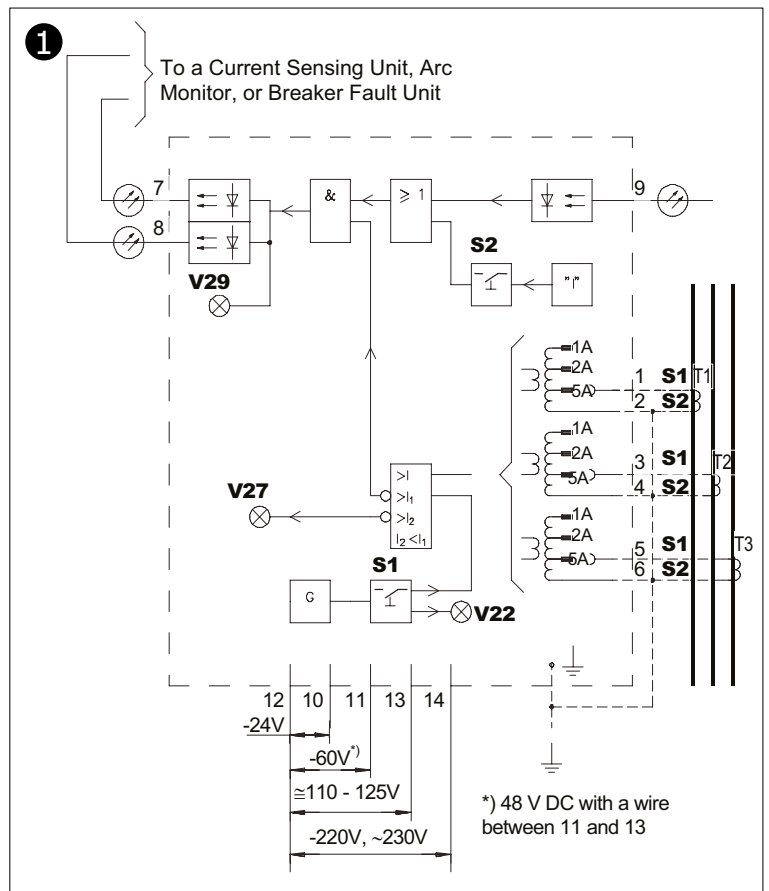
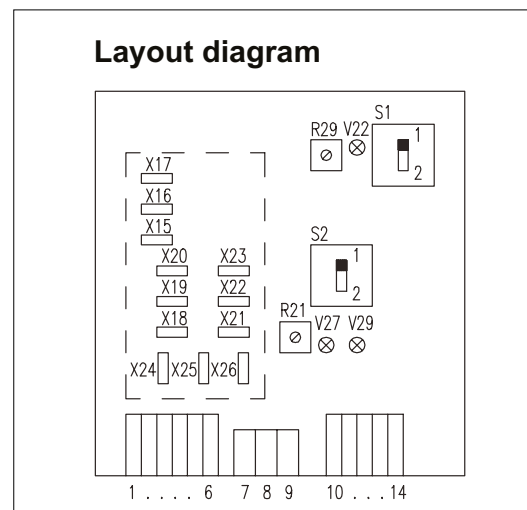

Table 5

Current range	Bridge connections
1A	X24-X17, X25-X20, X26-X23
2A	X24-X16, X25-X19, X26-X22
5A	X24-X15, X25-X18, X26-X21



1.7.2 Simplified block diagram

Table 5

A) Testing facilities:	
R29	Simulating a test current
S1	1= Test position 2= Operation position
V22	Red ON= S1 in test position OFF= S1 in operation position
B) Setting facilities:	
R21	Overcurrent setting
S2	1= Input 9 not used 2= Input 9 used
V27	Yellow ON= Load current <70% of set overcurrent level
V29	Green ON= Load current <100% of set overcurrent level OFF= Load current >100% of set overcurrent level
X) Current range bridge connections:	
1A	24- 17, 25- 20, 26- 23
2A	24- 16, 25- 19, 26- 22
5A	24- 15, 25- 18, 26- 21 On delivery

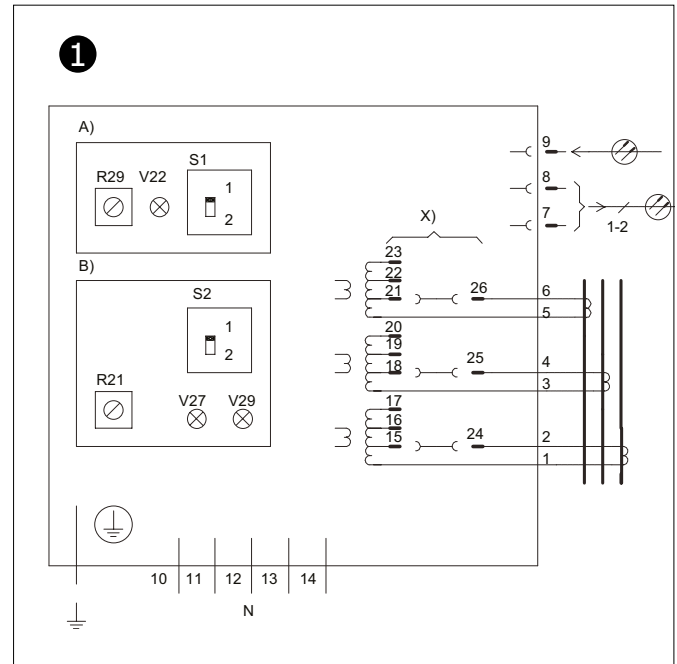

Terminals

1...6	Current transformer terminals
7...8	Optical output, current signal to a Current Sensing Unit or an Arc Monitor
9	Optical input, current signal from another Current Sensing Unit
10 and 12	24 V DC
11 and 12	60 V DC 48 V DC, with a wire between 11 and 13
13 and 12	110 - 125 V AC/DC
14 and 12	12 220 V DC, 230 V AC



ABB AB

Electrification Products Division

Low Voltage Products and Systems

Protection & Connection

Motorgränd 20

SE-721 61 Västerås / Sweden

You can find the address of your local sales organisation on the ABB home page.



<http://new.abb.com/low-voltage/products/arc-guard>



<http://www.abb.com/lowvoltage>

We reserve the right to make technical changes or modify the contents of this document without prior notice. ABB does not accept any responsibility whatsoever for potential errors or possible lack of information in this document.

We reserve all rights in this document and in the subject matter and illustrations contained therein. Any reproduction, disclosure to third parties or utilization of its contents – in whole or in parts – is forbidden without prior written consent of ABB.

Copyright© 2018 ABB - All rights reserved