

Product specification

Controller

S4Cplus

M2000

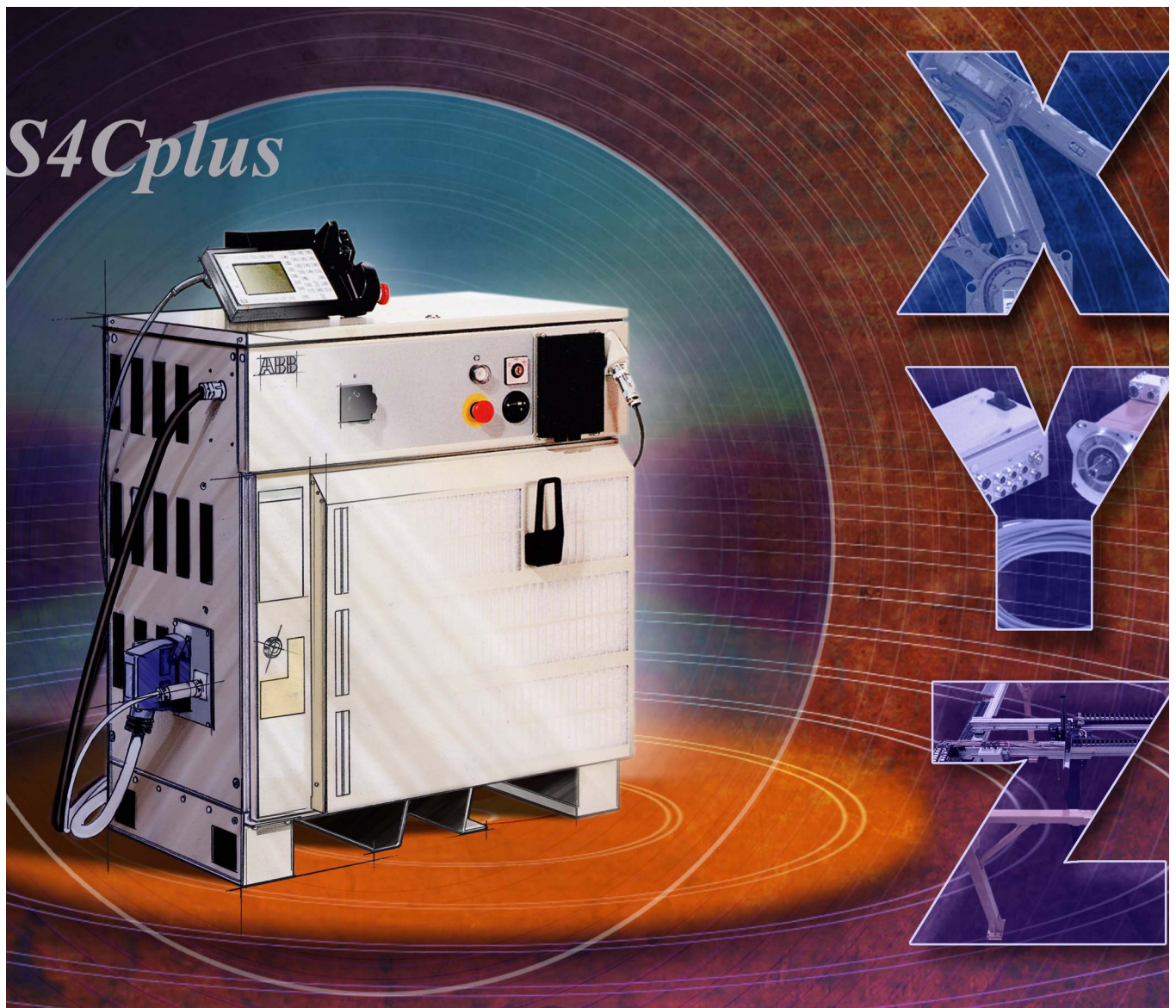

ABB

Product specification

Robot Controller

S4Cplus

M2000

3HAC 9039-1

Revision 7

The information in this manual is subject to change without notice and should not be construed as a commitment by ABB. ABB assumes no responsibility for any errors that may appear in this manual.

Except as may be expressly stated anywhere in this manual, nothing herein shall be construed as any kind of guarantee or warranty by ABB for losses, damages to persons or property, fitness for a specific purpose or the like.

In no event shall ABB be liable for incidental or consequential damages arising from use of this manual and products described herein.

This manual and parts thereof must not be reproduced or copied without ABB's written permission, and contents thereof must not be imparted to a third party nor be used for any unauthorized purpose. Contravention will be prosecuted.

Additional copies of this manual may be obtained from ABB at its then current charge.

©Copyright 2004 ABB All right reserved.

ABB Automation Technologies AB
Robotics
SE-721 68 Västerås
Sweden

1 Description	7
1.1 Structure	7
General	7
1.2 Safety/Standards	10
Health and safety standards	10
Safety system based on a two-channel circuit	10
Safety category 3	11
Selecting the operating mode	11
Reduced speed	11
Three position enabling device	11
Safe manual movement	12
Over-speed protection	12
Emergency stop	12
Safeguarded space stop	12
Delayed safeguarded space stop	12
Collision detection	12
Restricting the working space	12
Hold-to-run control	12
Fire safety	12
1.3 Operation	13
General	13
Portable teach pendant	14
Deflection of the joystick	15
User tasks	15
Motors on	16
Operating mode selector	16
External mounting	17
Remote control	17
1.4 Memory	18
Available memory	18
DRAM memory	18
Flash disk memory	18
Installation of different systems in the controller	19
RAPID memory consumption	19
Additional software options	19
1.5 Installation	20
Configuration for the corresponding manipulator	20
Operating requirements	20
Power supply	20
Rated power	20
Recommended max line fusing	21
Computer system	21
Configuration	21
1.6 Programming	22
General	22
Programming environment	22
Movements	22
The velocity	22
Program management	23
Editing programs	23
Change of robot position	23
Testing programs	23
1.7 Automatic Operation	24
General	24
Service position	24
Special routines	24
Absolute measurement	24

Table of Contents

1.8 The RAPID Language and Environment	25
General	25
1.9 Exception handling	25
General	25
1.10 Maintenance and Troubleshooting	26
Easy to service	26
Error detection	26
1.11 Robot Motion	26
QuickMove™	26
TrueMove™	27
Coordinate systems	27
1.12 External Axes	30
General	30
AC motor	30
Absolute position	30
External axes	31
1.13 I/O System	33
General	33
Input and output units	33
I/O Plus	33
Configuration of inputs and outputs	33
PLC	34
Available manual functions	34
Types of connection	34
ABB I/O units (node types)	35
Distributed I/O	36
Permitted customer load	36
Digital inputs 24 V DC (option 61-1/58-1/63-1)	36
Digital outputs 24 V DC (option 61-1/58-1)	36
Relay outputs (option 63-1)	37
Digital inputs 120 V AC (option 60-1)	37
Digital outputs 120 V AC (option 60-1)	37
Analog inputs (option 54-1)	38
Analog outputs (option 54-1)	38
Analog outputs (option 58-1)	38
System signals	39
1.14 Communication	40
General	40

2 Specification of Variants and Options	43
2.1 Introduction	43
General	43
2.2 Safety Standards	43
EU - Electromagnetic Compatibility	43
Underwriters Laboratories Inc.	43
2.3 Control System	44
Cabinet	44
Cabinet Height	44
Cabinet on wheels	45
Operator's panel	45
Operator's panel cable	47
Door lock insert	47
Operating mode selector	47
Controller cooling	48
Teach Pendant	48
Mains voltage	49
IRB 6600, IRB 6650, IRB 7600	49
IRB 140, IRB 1400, IRB 2400, IRB 4400, IRB 6400, IRB 340, IRB 640, IRB 940	49
Mains connection type	50
Mains switch	51
I/O Interfaces	52
Inputs/outputs	53
Connection of I/O	54
Safety signals	54
Field bus and communication	54
Variants	55
Gateway units	56
External I/O units	56
External gateway units	57
External axes in robot cabinet	58
Drive units	58
Servo gun interface	59
Stationary gun (SG)	59
Robot Gun (RG)	60
One SG and one RG	60
Twin SG	61
SG and Track Motion	62
RG and T	62
External axes measurement board	63
External axes - separate cabinet	63
Motor selection table	64
Drive unit	64
Drive unit DDU-VW/DDU-V/DDU-W	65
Equipment	65
Cable length	65
Protection for manipulator cable	66
Service outlet	66
Power supply	66
Memory	66

Table of Contents

1 Description

1.1 Structure

1.1.1 Introduction

General

The controller contains the electronics required to control the manipulator, external axes and peripheral equipment.

The controller also contains the system software, i.e. the BaseWare OS (operating system), which includes all basic functions for operation and programming.

Data	Description
Controller weight	250 kg
Controller volume:	950 x 800 x 620 mm
Airborne noise level	The sound pressure level outside the working space < 70 dB (A) Leq (acc. to Machinery directive 98/37/EEC)

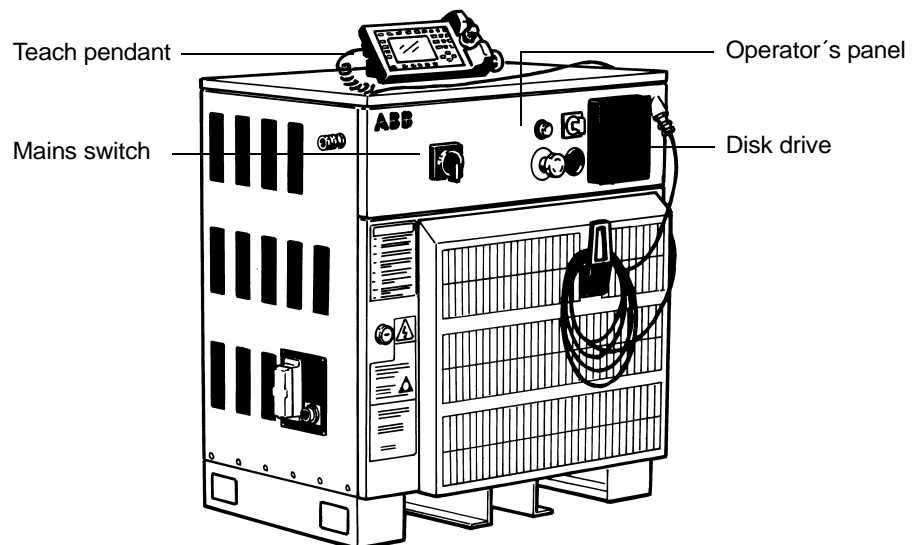

Figure 1 The controller is specifically designed to control robots, which means that optimal performance and functionality is achieved.

1 Description

1.1.1 Introduction

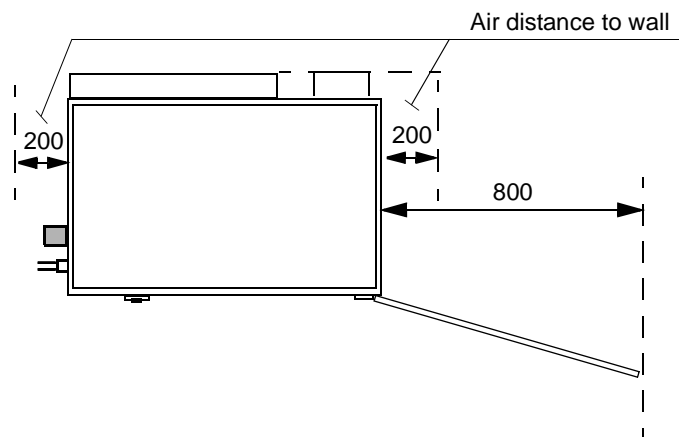

Figure 2 View of the controller from above (dimensions in mm).

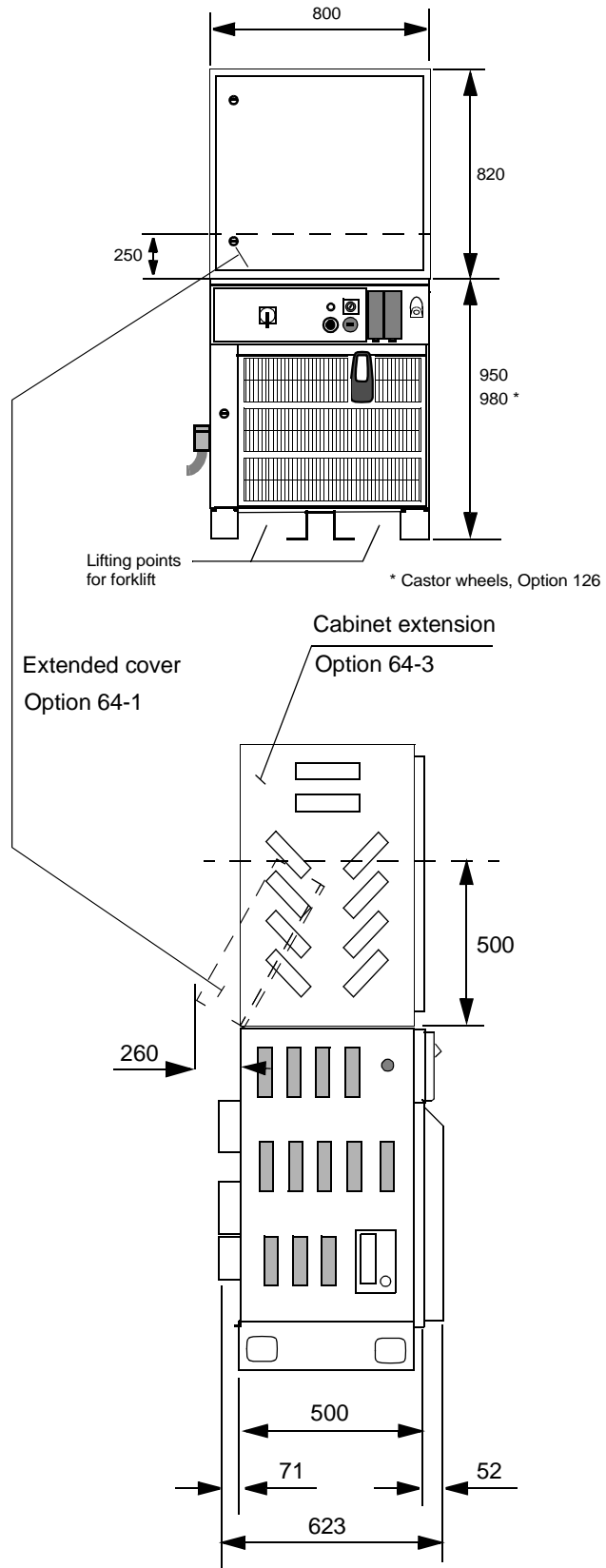

Figure 3 View of the controller from the front and from the side (dimensions in mm).

1 Description

1.2.1 Standards

1.2 Safety/Standards

1.2.1 Standards

The robot conforms to the following standards:

Standard	Description
EN ISO 12100 -1	Safety of machinery, terminology
EN ISO 12100 -2	Safety of machinery, technical specifications
EN 954-1	Safety of machinery, safety related parts of control systems
EN 60204	Electrical equipment of industrial machines
EN 775	Electrical equipment of industrial machines
EN 61000-6-4 (option)	EMC, Generic emission
EN 61000-6-2	EMC, Generic immunity

Standard	Description
IEC 204-1	Electrical equipment of industrial machines
IEC 529	Degrees of protection provided by enclosures

Standard	Description
ISO 10218	Manipulating industrial robots, safety
ISO 9787	Manipulating industrial robots, coordinate systems and motions

Standard	Description
ANSI/RIA 15.06/1999	Safety Requirements for Industrial Robots and Robot Systems
ANSI/UL 1740-1998 (option)	Safety Standard for Robots and Robotic Equipment
CAN/CSA Z 434-03 (option)	Industrial Robots and Robot Systems - General Safety Requirements

Health and safety standards

The robot complies fully with the health and safety standards specified in the EEC's Machinery Directives.

Safety system based on a two-channel circuit

The robot controller is designed with absolute safety in mind. It has a dedicated safety system based on a two-channel circuit which is monitored continuously. If any

component fails, the electrical power supplied to the motors shuts off and the brakes engage.

Safety category 3

Malfunction of a single component, such as a sticking relay, will be detected at the next MOTOR OFF/MOTOR ON operation. MOTOR ON is then prevented and the faulty section is indicated. This complies with category 3 of EN 954-1, Safety of machinery - safety related parts of control systems - Part 1.

Selecting the operating mode

The robot can be operated either manually or automatically. In manual mode, the robot can only be operated via the teach pendant, i.e. not by any external equipment.

Reduced speed

In manual mode, the speed is limited to a maximum of 250 mm/s (600 inch/min.). The speed limitation applies not only to the TCP (Tool Center point), but to all parts of the robot. It is also possible to monitor the speed of equipment mounted on the robot.

Three position enabling device

The enabling device on the teach pendant must be used to move the robot when in manual mode. The enabling device consists of a switch with three positions, meaning that all robot movements stop when either the enabling device is pushed fully in, or when it is released completely. This makes the robot safer to operate.

1 Description

1.2.1 Standards

Safe manual movement	The robot is moved using a joystick instead of the operator having to look at the teach pendant to find the right key.
Over-speed protection	The speed of the robot is monitored by two independent computers.
Emergency stop	There is one emergency stop push button on the controller and another on the teach pendant. Additional emergency stop buttons can be connected to the robot's safety chain circuit.
Safeguarded space stop	The controller has a number of electrical inputs which can be used to connect external safety equipment, such as safety gates and light curtains. This allows the robot's safety functions to be activated both by peripheral equipment and by the robot itself.
Delayed safeguarded space stop	A delayed stop gives a smooth stop. The robot stops in the same way as at a normal program stop with no deviation from the programmed path. After approx. 1 second the power supplied to the motors shuts off.
Collision detection	In case an unexpected mechanical disturbance like a collision, electrode sticking, etc. occurs, the robot will stop and slightly back off from its stop position.
Restricting the working space	The movement of each axis can be restricted using software limits. There are safeguarded space stops for connection of limit switches to restrict the working space. For some robots the axes 1-3 can also be restricted by means of mechanical stops.
Hold-to-run control	"Hold-to-run" means that you must depress the start button in order to move the robot. When the button is released the robot will stop. The hold-to-run function makes program testing safer.
Fire safety	Both the manipulator and control system comply with UL's (Underwriters Laboratory) tough requirements for fire safety.

1.3 Operation

1.3.1 Teach pendant

General

All operations and programming can be carried out using the portable teach pendant (see Figure 4) and operator's panel (see Operating mode selector).

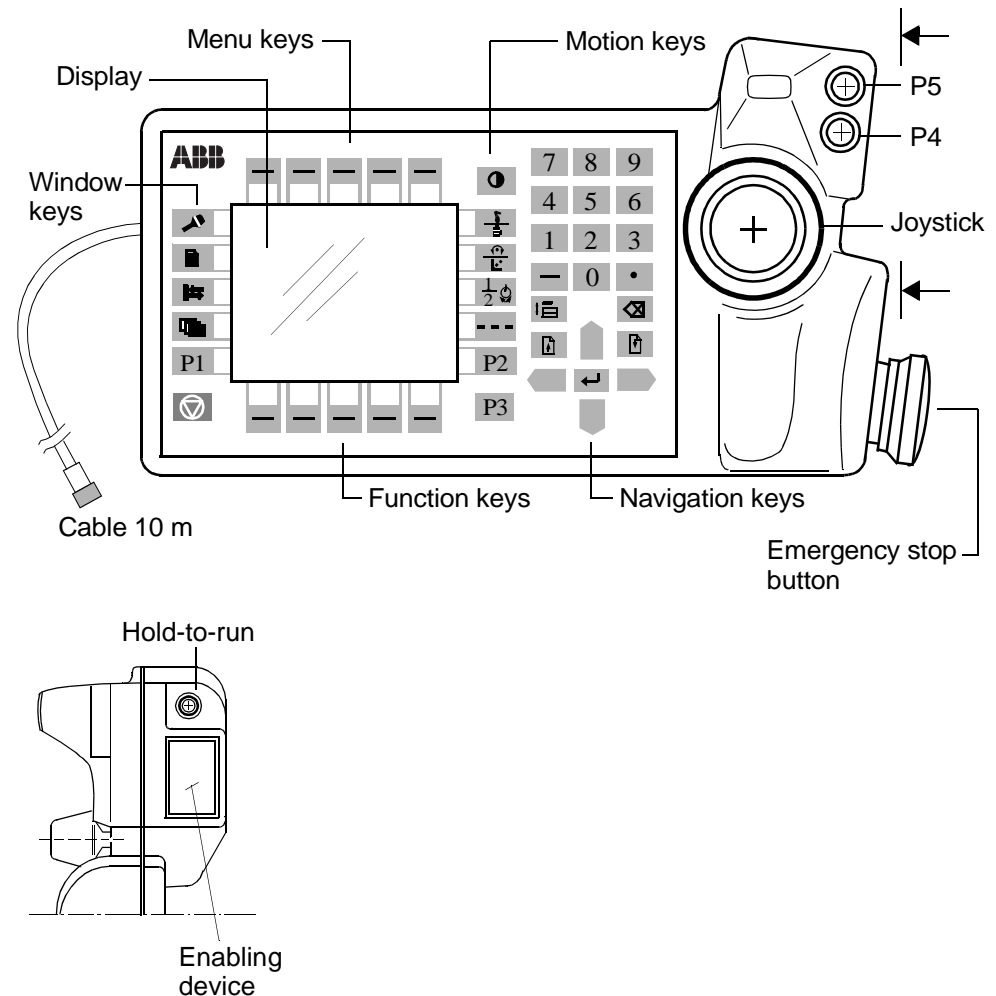

Figure 4 The teach pendant is equipped with a large display, which displays prompts, information, error messages and other information in plain English.

Information is presented on a display using windows, pull-down menus, dialogs and function keys. No previous programming or computer experience is required to learn how to operate the robot. All operations can be carried out from the teach pendant, which means that an additional keyboard is not required. All information, including the complete programming language, is in English or, if preferred, some other major language. (Available languages, see options for Teach Pendant Languages in Specification of Variants and Options)



1 Description

1.3.1 Teach pendant

Portable teach pendant

Features	Description
Display	Displays all information during programming, to change programs, etc. 16 text lines with 40 characters per line.
Motion keys	Select the type of movement when jogging.
Navigation keys	Used to move the cursor within a window on the display and enter data.
Menu keys	Display pull-down menus, see Figure 5.
Function keys	Select the commands used most often.
Window keys	Display one of the robot's various windows. These windows control a number of different functions: Jog (manual operation) Program, edit and test a program Manual input/output management File management System configuration Service and troubleshooting Automatic operation
User-defined keys (P1-P5)	Five user-defined keys that can be configured to set or reset an output (e.g. open/close gripper) or to activate a system input.
Hold-to-run	A push button which must be pressed when running the program in manual mode with full speed.
Enabling device	A push button which, when pressed halfway in, takes the system to MOTORS ON. When the enabling device is released or pushed all the way in, the robot is taken to the MOTORS OFF state.
Joystick	The joystick is used to jog (move) the robot manually; e.g. when programming the robot.
Emergency stop button	The robot stops immediately when the button is pressed in.

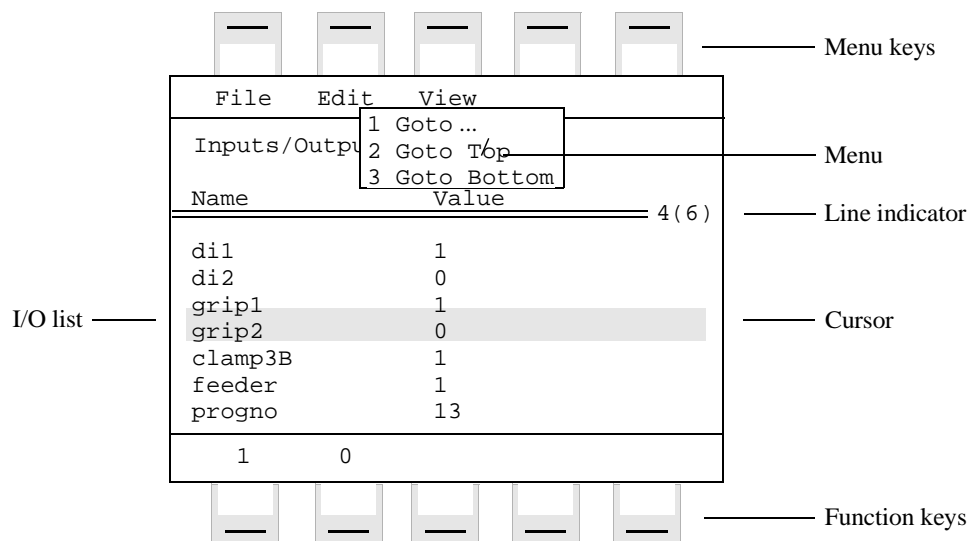

Figure 5 Window for manual operation of input and output signals.

Deflection of the joystick

Using the joystick, the robot can be manually jogged (moved). The user determines the speed of this movement; large deflections of the joystick will move the robot quickly, smaller deflections will move it more slowly.

User tasks

The robot supports different user tasks, with dedicated windows for:

- Production
- Programming
- System setup
- Service and installation

1 Description

1.3.2 Operator's panel

1.3.2 Operator's panel

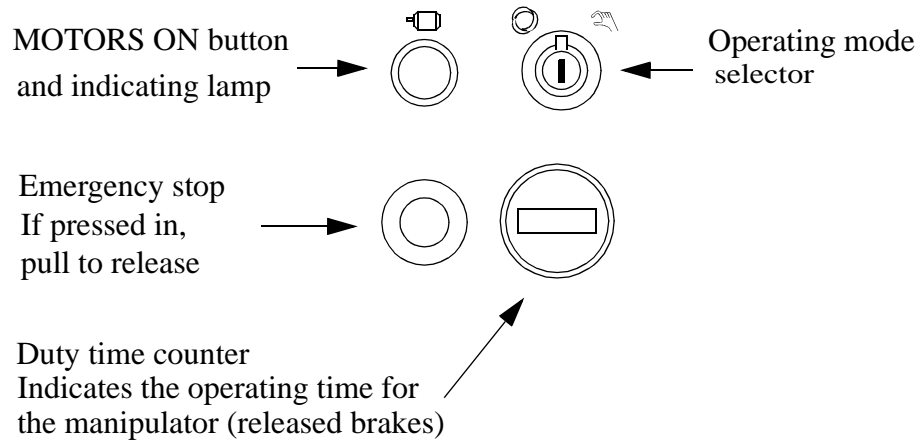



Motors on

MOTORS ON	Operation	Note
Continuous light	Ready for program execution	
Fast flashing light (4Hz)	The robot is not calibrated or the revolution counters are not updated	The motors have been switched on
Slow flashing light (1 Hz)	One of the safeguarded space stops is active	The motors have been switched off

Operating mode selector

Using a key switch, the robot can be locked in two (or three) different operating modes depending on chosen mode selector.

Operating mode	Description	Signs
Automatic mode	Running production	
Manual mode at reduced speed	Programming and setup Max. speed 250 mm/s (600 inches/min.)	

As optional	Description	Signs
Manual mode at full speed	Testing at full program speed	

Equipped with this mode, the robot is not approved according to ANSI/UL.
The operating mode is selected using the operator's panel on the controller.

External mounting

Both the operator's panel and the teach pendant can be mounted externally, i.e. separated from the cabinet. The robot can then be controlled from there.

Remote control

The robot can be remotely controlled from a computer, PLC or from a customer's panel, using serial communication or digital system signals.



For more information on how to operate the robot, see the User's Guide.

1 Description

1.3.2 Operator's panel

1.4 Memory

Available memory The controller has two different memories:

Memory	Size	Usage
Fixed DRAM memory	32 MB	working memory
Flash disk memory	64 MB, standard	mass memory
Flash disk memory	128 MB, optional	mass memory

DRAM memory The DRAM memory is used for running the system software and the user programs and it is thus divided into three areas:

DRAM memory	Size	Option
System software		
System software execution data		
User RAPID see Figure 6	5.5 MB 0.7 MB (at most)	when installing different options, the user program memory will decrease

Flash disk memory

The flash disk is divided into four main areas:

Main areas	Size	Description
Base area	5 MB	permanent code for booting
Release area	20 MB	the code for a specific release is stored
System specific data area	10 MB	the run time specific data including the user program for a system is stored at backup
User mass memory area		can be used for storing RAPID programs, data, logs etc

The flash disk is used for backup, i.e. when a power failure occurs or at power off, all the system specific data including the user program, see Figure 6, will be stored on the flash disk and restored at power on. A backup power system (UPS) ensures the automatic storage function.

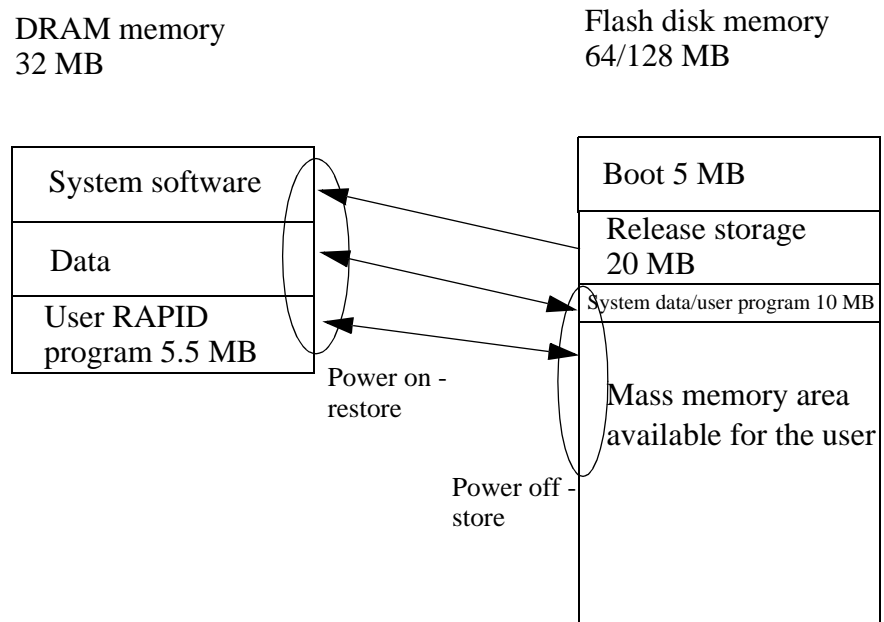

Figure 6 Available memory.

Installation of different systems in the controller

Several different systems, i.e. process applications, may be installed at the same time in the controller, of which one can be active. Each such application will occupy another 10 MB of the flash memory for system data. The release storage area will be in common as long as the process applications are based on the same release. If two different releases should be loaded, the release storage area must also be doubled.

RAPID memory consumption

For RAPID memory consumption, see RAPID Developer's Manual. As an example, a MoveL or MoveJ instruction consumes 236 bytes when the robtarg is stored in the instruction (marked with '*') and 168 bytes if a named robtarg is used. In the latter case, the CONST declaration of the named robtarg consumes an additional 280 bytes.

Additional software options

Additional software options will reduce the available user program memory, most of them however only marginally, i.e. the user program area will still be about 5.5 MB. Only the SpotWare option will reduce memory significantly, i.e. down to about 4.8 MB depending on the number of simultaneous welding guns.

1 Description

1.3.2 Operator's panel

1.5 Installation

Configuration for the corresponding manipulator

The controller is delivered with a standard configuration for the corresponding manipulator, and can be operated immediately after installation. Its configuration is displayed in plain language and can easily be changed using the teach pendant.

Operating requirements

Requirements	Description
Protection standard IEC529	Controller electronics IP54
Explosive environments	The controller must not be located or operated in an explosive environment.
Ambient temperature during operation	option 85-1: +5°C (+41°F) to +45°C (+113°F) option 85-2: +52°C (+125°F)
Ambient temperature during transportation and storage	-25°C (-13°F) to +55°C (+131°F) For short periods (not exceeding 24 hours) up to +70°C (+158°F)
Relative humidity transportation, storage and operation	Max. 95% at constant temperature
Vibration during transportation and storage	0-55 Hz: Max. ± 0.15 mm 55-150 Hz: Max. 20 m/s^2
Bumps during transportation and storage	Max. 100 m/s^2 (4-7 ms)

Power supply

Description	Value
Mains voltage	200-600 V, 3ph (3ph + N for certain options)
Mains voltage tolerance	+10%, -15%
Mains frequency	48.5 to 61.8 Hz

Rated power

Robot		Values
IRB 140, 1400, 2400	standard	4.5 kVA (transformer size)
IRB 140, 1400, 2400	external axes	8.3 kVA (transformer size)
IRB 340, 4400, 640, 6400, 940		8.3 kVA (transformer size)
IRB 6600-225/2.55		6 kVA (ISO 9283)
IRB 7600-400/2.55		7.1 kVA (ISO 9283)

Recommended max line fusing

Recommended line fusing (if not included as optional circuit breaker).

Robot	Voltage	Description
IRB 140-940	at 400-600V	3x16A slow-blowing
	at 200-220V	3x25A slow-blowing
IRB 6600-7600	at 400-600V	3x25A slow-blowing
	at 200-220V	3x35A slow-blowing

Computer system

Description	Value
Backup capacity at power interrupt	20 sec (rechargeable battery)

Configuration

The robot is very flexible and can, by using the teach pendant, easily be configured to suit the needs of each user:

User needs	Description
Authorisation	Password protection for configuration and program window
Most common I/O	User-defined lists of I/O signals
Instruction pick list	User-defined set of instructions
Instruction builder	User-defined instructions
Operator dialogs	Customised operator dialogs
Language	All text on the teach pendant can be displayed in several languages
Date and time	Calendar support
Power on sequence	Action taken when the power is switched on
EM stop sequence	Action taken at an emergency stop
Main start sequence	Action taken when the program is starting from the beginning
Program start sequence	Action taken at program start
Program stop sequence	Action taken at program stop
Change program sequence	Action taken when a new program is loaded
Working space	Working space limitations
External axes	Number, type, common drive unit, mechanical units
Brake delay time	Time before brakes are engaged
I/O signal	Logical names of boards and signals, I/O mapping, cross connections, polarity, scaling, default value at start up, interrupts, group I/O
Serial communication	Configuration

For a detailed description of the installation procedure, see the Product Manual - Installation and Commissioning.

1 Description

1.3.2 Operator's panel

1.6 Programming

General

Programming the robot involves choosing instructions and arguments from lists of appropriate alternatives. Users do not need to remember the format of instructions, since they are prompted in plain English. “See and pick” is used instead of “remember and type”.

Programming environment

The programming environment can be easily customized using the teach pendant.

- Shop floor language can be used to name programs, signals, counters, etc.
- New instructions can be easily written.
- The most common instructions can be collected in easy-to-use pick lists.
- Positions, registers, tool data, or other data, can be created.

Programs, parts of programs and any modifications can be tested immediately without having to translate (compile) the program.

Movements

A sequence of movements is programmed as a number of partial movements between the positions to which you want the robot to move.

The end position of a movement is selected either by manually jogging the robot to the desired position with the joystick, or by referring to a previously defined position.

The exact position can be defined (see Figure 7) as:

- a stop point, i.e. the robot reaches the programmed position
- or
- a fly-by point, i.e. the robot passes close to the programmed position. The size of the deviation is defined independently for the TCP, the tool orientation and the external axes.

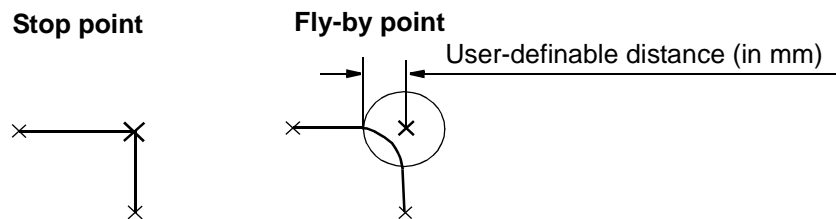

Figure 7 The fly-by point reduces the cycle time since the robot does not have to stop at the programmed point. The path is speed independent.

The velocity

The velocity may be specified in the following units:

Units	Velocity
mm/s	
seconds	time it takes to reach the next programmed position
degrees/s	for reorientation of the tool or for rotation of an external axis

Program management

For convenience, the programs can be named and stored in different directories. The mass memory can also be used for program storage. These can then be automatically downloaded using a program instruction. The complete program or parts of programs can be transferred to/from the network or a diskette. The program is stored as a normal PC text file, which means that it can be edited using a standard PC.

Editing programs

Programs can be edited using standard editing commands, i.e. “cut-and-paste”, copy, delete, find and change, undo etc. Individual arguments in an instruction can also be edited using these commands. No reprogramming is necessary when processing left-hand and right-hand parts, since the program can be mirrored in any plane.

Change of robot position

A robot position can easily be changed either by

- jogging the robot with the joystick to a new position and then pressing the “ModPos” key (this registers the new position)
- or by
- entering or modifying numeric values.

To prevent unauthorised personnel from making program changes, passwords can be used.

Testing programs

Several helpful functions can be used when testing programs. For example, it is possible to

- start from any instruction
- execute an incomplete program
- run a single cycle
- execute forward/backward step-by-step
- simulate wait conditions
- temporarily reduce the speed
- change a position
- tune (displace) a position during program execution.

For more information, see the User's Guide and RAPID Reference Manual.



1 Description

1.3.2 Operator's panel

1.7 Automatic Operation

General

A dedicated production window with commands and information required by the operator is automatically displayed during automatic operation.

The operation procedure can be customised to suit the robot installation by means of user-defined operating dialogs.

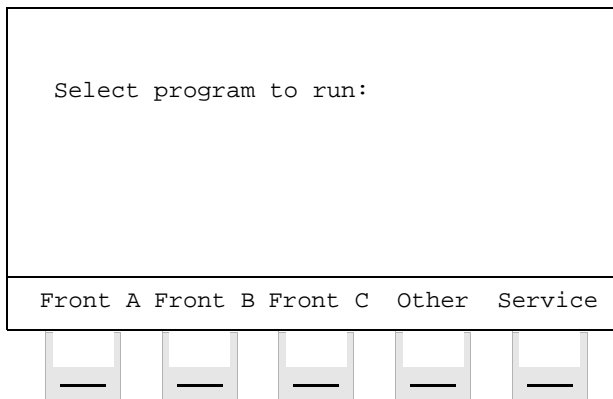

Figure 8 The operator dialogs can be easily customised.

Service position

A special input can be set to order the robot to go to a service position. After service, the robot is ordered to return to the programmed path and continue program execution.

Special routines

You can also create special routines that will be automatically executed when the power is switched on, at program start and on other occasions. This allows you to customise each installation and to make sure that the robot is started up in a controlled way.

Absolute measurement

The robot is equipped with absolute measurement, making it possible to operate the robot directly when the power is switched on. For your convenience, the robot saves the used path, program data and configuration parameters so that the program can be easily restarted from where you left off. Digital outputs are also set automatically to the value prior to the power failure.

1.8 The RAPID Language and Environment

General

The RAPID language is a well balanced combination of simplicity, flexibility and powerfulness. It contains the following concepts:

- Hierarchical and modular program structure to support structured programming and reuse.
- Routines can be Functions or Procedures.
- Local or global data and routines.
- Data typing, including structured and array data types.
- User defined names (shop floor language) on variables, routines and I/O.
- Extensive program flow control.
- Arithmetic and logical expressions.
- Interrupt handling.
- Error handling (for exception handling in general, see Exception handling).
- User defined instructions (appear as an inherent part of the system).
- Backward handler (user definition of how a procedure should behave when stepping backwards).
- Many powerful built-in functions, e.g mathematics and robot specific.
- Unlimited language (no max. number of variables etc., only memory limited).

Windows based man machine interface with built-in RAPID support (e.g. user defined pick lists).

1.9 Exception handling

General

Many advanced features are available to make fast error recovery possible. Characteristic is that the error recovery features are easy to adapt to a specific installation in order to minimise down time. Examples:

- Error Handlers (automatic recovery often possible without stopping production).
- Restart on Path.
- Power failure restart.
- Service routines.
- Error messages: plain text with remedy suggestions, user defined messages.
- Diagnostic tests.
- Event logging.

1 Description

1.3.2 Operator's panel

1.10 Maintenance and Troubleshooting

Easy to service

The controller requires only a minimum of maintenance during operation. It has been designed to make it as easy to service as possible:

- The controller is enclosed, which means that the electronic circuitry is protected when operating in a normal workshop environment.
- There is a supervision of temperature, fans and battery health.

Error detection

The controller has several functions to provide efficient diagnostics and error reports:

- It performs a self-test when power on is set.
- Computer status LEDs and console (serial channel) for fault tracing support.
- Errors are indicated by a message displayed in plain language. The message includes the reason for the fault and suggests recovery action.
- Faults and major events are logged and time-stamped. This makes it possible to detect error chains and provides the background for any downtime. The log can be read on the teach pendant display, stored in a file or printed on a printer.
- There are commands and service programs in RAPID to test units and functions.
- LEDs on the panel unit indicate status of the safeguarded switches.

Most errors detected by the user program can also be reported to and handled by the standard error system. Error messages and recovery procedures are displayed in plain language.



For detailed information on maintenance procedures, see Maintenance section in the Product Manual.

1.11 Robot Motion

QuickMove™

The QuickMove™ concept means that a self-optimizing motion control is used. The robot automatically optimizes the servo parameters to achieve the best possible performance throughout the cycle – based on load properties, location in working area, velocity and direction of movement.

- No parameters have to be adjusted to achieve correct path, orientation and velocity.
- Maximum acceleration is always obtained (acceleration can be reduced, e.g. when handling fragile parts).
- The number of adjustments that have to be made to achieve the shortest possible cycle time is minimized.

TrueMove™

The TrueMove™ concept means that the programmed path is followed – regardless of the speed or operating mode – even after an emergency stop, a safeguarded stop, a process stop, a program stop or a power failure.

This very accurate path and speed is based on advanced dynamic modelling.

Coordinate systems

BaseWare includes a very powerful concept of multiple coordinate systems that facilitates jogging, program adjustment, copying between robots, off-line programming, sensor based applications, external axes co-ordination etc. Full support for TCP (Tool Center Point) attached to the robot or fixed in the cell (“Stationary TCP”).

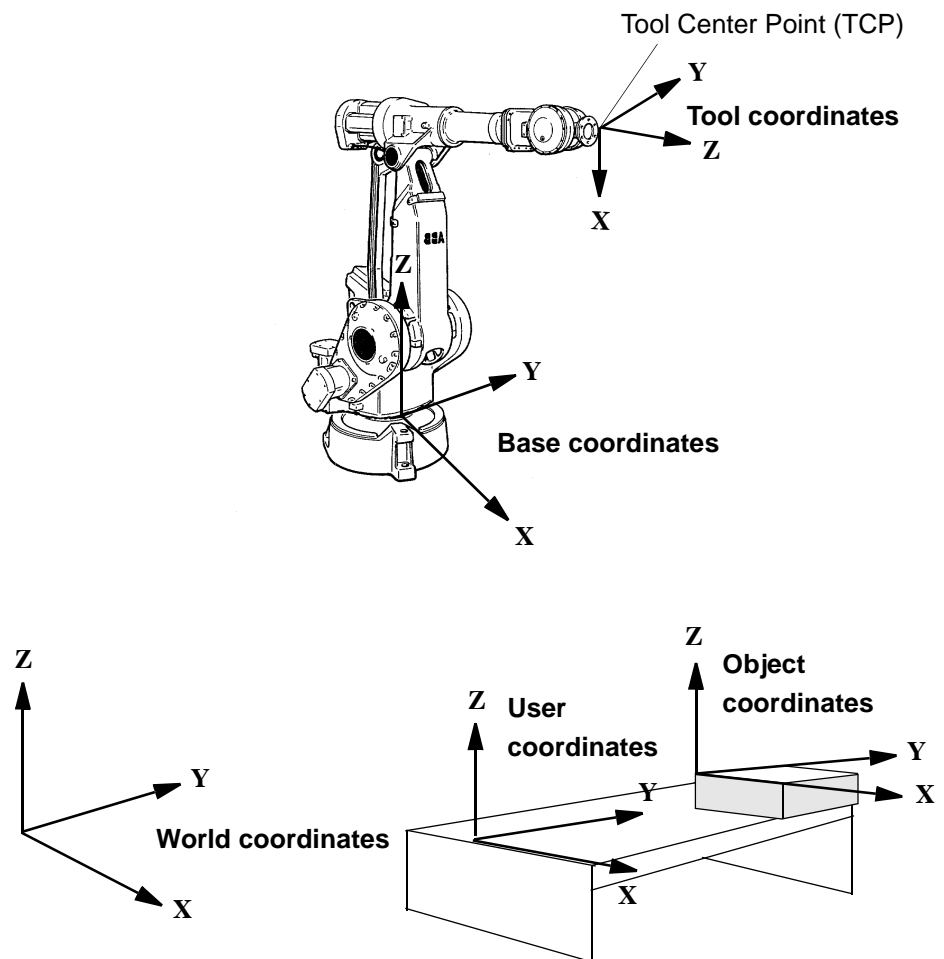

Figure 9 The coordinate systems, used to make jogging and off-line programming easier.

1 Description

1.3.2 Operator's panel

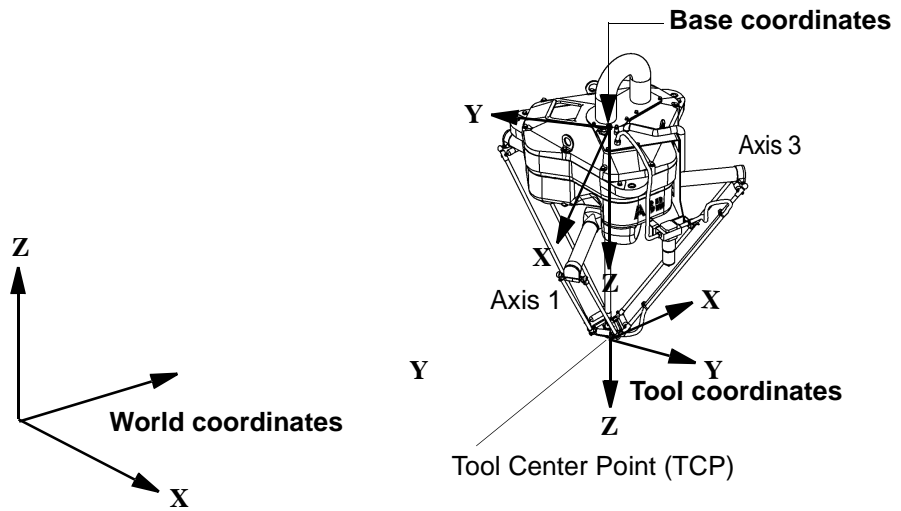

Figure 10 The coordinate systems, used to make jogging and off-line programming easier

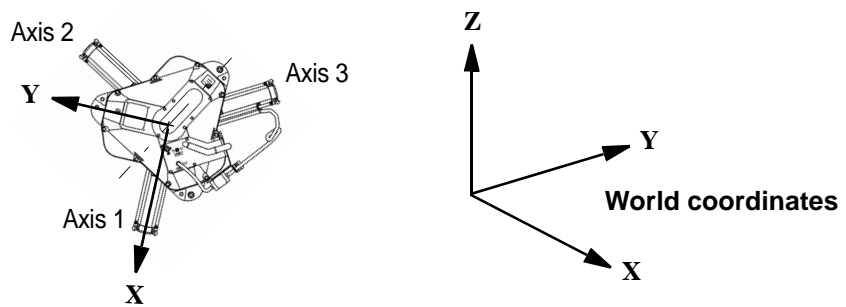

Figure 11 The coordinate systems, used to make jogging and off-line programming easier.

System	Description
World coordinate system	The world coordinate system defines a reference to the floor, which is the starting point for the other coordinate systems. Using this coordinate system, it is possible to relate the robot position to a fixed point in the workshop. The world coordinate system is also very useful when two robots work together or when using a robot carrier.
Base coordinate system	The base coordinate system is attached to the base mounting surface of the robot.
Tool coordinate system	The tool coordinate system specifies the tool's center point and orientation.
User coordinate system	The user coordinate system specifies the position of a fixture or workpiece manipulator.

System	Description
Object coordinate system	<p>The object coordinate system specifies how a workpiece is positioned in a fixture or workpiece manipulator.</p> <p>The coordinate systems can be programmed by specifying numeric values or jogging the robot through a number of positions (the tool does not have to be removed).</p> <p>Each position is specified in object coordinates with respect to the tool's position and orientation. This means that even if a tool is changed because it is damaged, the old program can still be used, unchanged, by making a new definition of the tool.</p> <p>If a fixture or workpiece is moved, only the user or object coordinate system has to be redefined.</p>
Stationary TCP	<p>When the robot is holding a work object and working on a stationary tool, it is possible to define a TCP for that tool. When that tool is active, the programmed path and speed are related to the work object.</p>
Program execution	<p>The robot can move in any of the following ways:</p> <ul style="list-style-type: none"> -Joint motion (all axes move individually and reach the programmed position at the same time) -Linear motion (the TCP moves in a linear path) -Circle motion (the TCP moves in a circular path).
Soft servo	<p>Soft servo - allowing external forces to cause deviation from programmed position - can be used as an alternative to mechanical compliance in grippers, where imperfection in processed objects can occur.</p>
Location	<p>If the location of a workpiece varies from time to time, the robot can find its position by means of a digital sensor. The robot program can then be modified in order to adjust the motion to the location of the part.</p>
Jogging	<p>The robot can be manually operated in any one of the following ways:</p> <ul style="list-style-type: none"> -Axis-by-axis, i.e. one axis at a time. -Linearly, i.e. the TCP moves in a linear path (relative to one of the coordinate systems mentioned above). -Reoriented around the TCP. <p>It is possible to select the step size for incremental jogging. Incremental jogging can be used to position the robot with high precision, since the robot moves a short distance each time the joystick is moved.</p> <p>During manual operation, the current position of the robot and the additional axes can be displayed on the teach pendant.</p>
Singularity handling	<p>The robot can pass through singular points in a controlled way, i.e. points where two axes coincide.</p>
Motion supervision	<p>Very flexible possibilities to configure external axes. Includes for instance high performance coordination with robot movement and shared drive unit for several axes.</p>
External axes	<p>Very flexible possibilities to configure additional motors. Includes, for instance, high performance coordination with robot movement and shared drive unit for several motors.</p>

1 Description

1.3.2 Operator's panel

System	Description
Big Inertia	One side effect of the dynamic model concept is that the system can handle very big load inertias by automatically adapting the performance to a suitable level. For big, flexible objects it is possible to optimise the servo tuning to minimize load oscillation.
Soft Servo	Any motors (also additional) can be switched to soft servo mode, which means that it will adopt a spring-like behaviour.

1.12 External Axes

General

The controller can control up to six external axes. These axes are programmed and moved using the teach pendant in the same way as the robot's axes.

	Description
Mechanical units	The external axes can be grouped into mechanical units to facilitate, for example, the handling of robot carriers, workpiece manipulators, etc.
Coordination	The robot motion can be simultaneously coordinated with for example, a linear robot carrier and a work piece positioner.
Activate/Deactivate	A mechanical unit can be activated or deactivated to make it safe when, for example, manually changing a workpiece located on the unit. In order to reduce investment costs, any axes that do not have to be active at the same time, can share the same drive unit.

AC motor

An external axis is an AC motor (IRB motor type or similar) controlled via a drive unit mounted in the robot cabinet or in a separate enclosure. See Specification of Variants and Options.

Specification	Description
Resolver	Connected directly to motor shaft Transmitter type resolver Voltage ratio 2:1 (rotor: stator)
Resolver supply	5.0 V/4 kHz

Absolute position

Absolute position is accomplished by battery-backed resolver revolution counters in the serial measurement board (SMB). The SMB is located close to the motor(s) according to Figure 12.



For more information on how to install an external axis, see the User's Guide - External Axes

External axes

Robot type	Description
IRB 4400 and IRB 6400X	When more than one external axis is used, the drive units for external axis 2 and upwards must be located in a separate cabinet as shown in Figure 12.
IRB 140, IRB 1400, and IRB 2400	When more than three external axes are used, the drive units for external axis 4 and upwards must be located in a separate cabinet as shown in Figure 12.
IRB 6600 and IRB 7600	The drive units for all external axes must be located in a separate cabinet as shown in Figure 12.

1 Description

1.3.2 Operator's panel

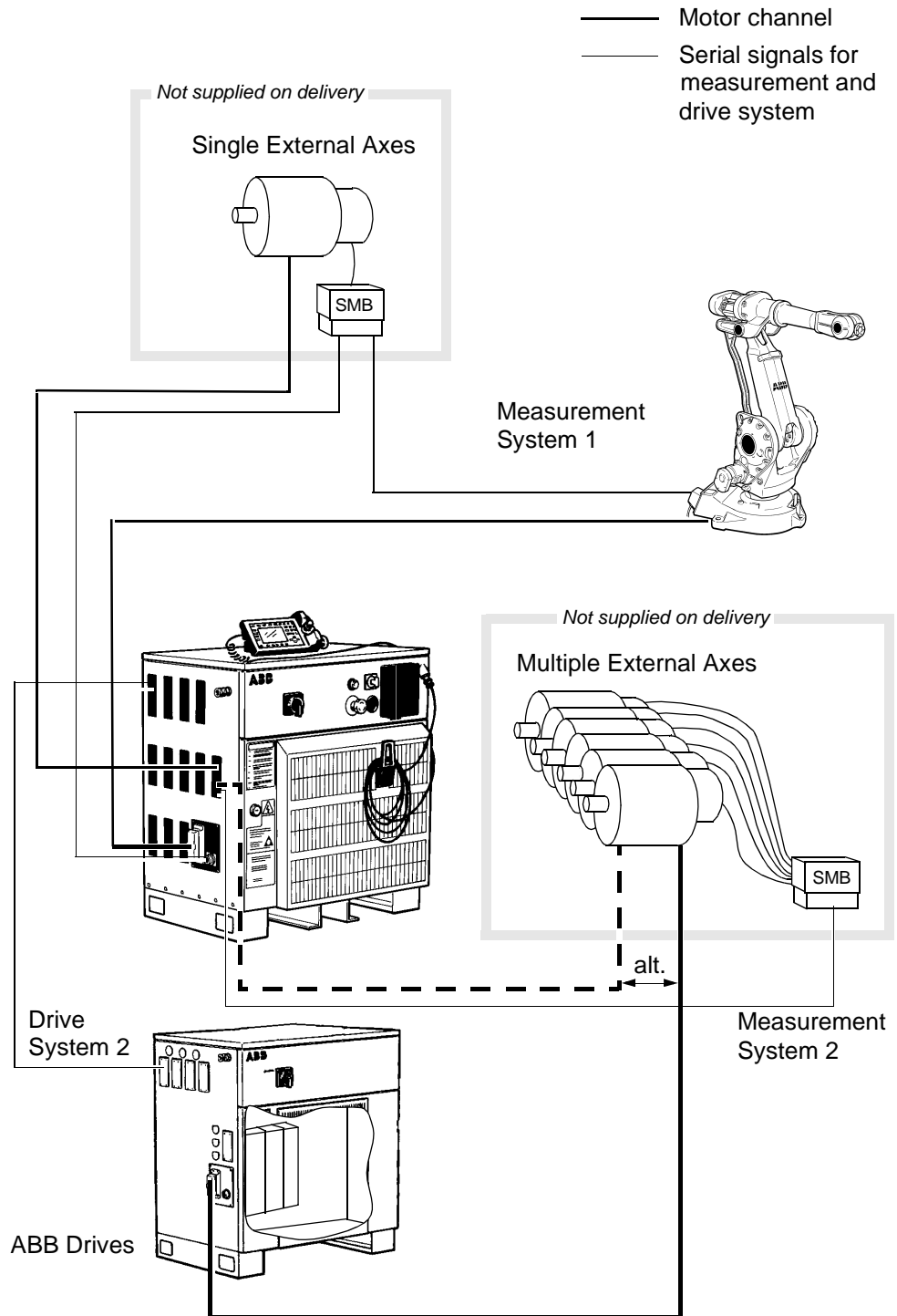

Figure 12 Outline diagram, external axes.

1.13 I/O System

General

A distributed I/O system is used, based on the fieldbus standard CAN/DeviceNet. This makes it possible to mount the I/O units either inside the cabinet or outside the cabinet with a cable connecting the I/O unit to the cabinet.

Two independent CAN/DeviceNet buses allow various conditions of I/O handling. Both channels can be operating as master or slave. One bus, CAN1, is operating with fixed data rate, and the other, CAN2 (accessible by the software option I/O Plus), with different data rates.

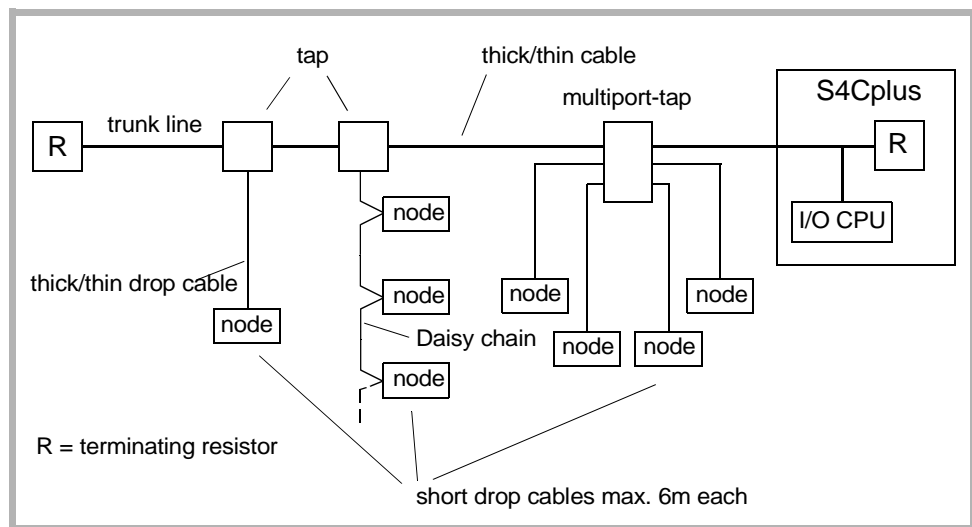

Figure 13 Example of a general DeviceNet bus.

Input and output units

A number of different input and output units can be installed:

- Digital inputs and outputs.
- Analog inputs and outputs.
- Gateway (slave) for Allen-Bradley Remote I/O.
- Gateway (slave) for Interbus Slave.
- Gateway (slave) for Profibus DP Slave.

I/O Plus

S4Cplus with the option I/O Plus can be configured for fieldbus units from other suppliers. For more details see the Product Specification RobotWare Options.

Configuration of inputs and outputs

The inputs and outputs can be configured to suit your installation:

- Each signal and unit can be given a name, e.g. gripper, feeder.
- I/O mapping (i.e. a physical connection for each signal).
- Polarity (active high or low).
- Cross connections.
- Up to 16 digital signals can be grouped together and used as if they were a single signal when, for example, entering a bar code.

1 Description

1.3.2 Operator's panel

- Sophisticated error handling.
- Selectable "trust level" (i.e. what action to take when a unit is "lost").
- Program controlled enabling/disabling of I/O units.
- Scaling of analog signals.
- Filtering.
- Polarity definition.
- Pulsing.
- TCP-proportional analog signal.
- Programmable delays.
- Simulated I/O (for forming cross connections or logical conditions without need the for physical hardware).
- Accurate coordination with motion.

PLC

Signals can be assigned to special system functions, such as program start, so as to be able to control the robot from an external panel or PLC.

The robot can function as a PLC by monitoring and controlling I/O signals:

- I/O instructions are executed concurrent to the robot motion.
- Inputs can be connected to trap routines. (When such an input is set, the trap routine starts executing. Following this, normal program execution resumes. In most cases, this will not have any visible effect on the robot motion, i.e. if a limited number of instructions are executed in the trap routine.)
- Background programs (for monitoring signals, for example) can be run in parallel with the actual robot program. Requires Multitasking option, see Product Specification RobotWare.

Available manual functions

- List all the signal values.
- Create your own list of your most important signals.
- Manually change the status of an output signal.
- Print signal information on a printer.

I/O signals can for some robots also be routed parallel or serial to connectors on the upper arm of the robot.

Types of connection

The following types of connection are available:

- "Screw terminals" on the I/O units
- Industrial connectors on cabinet wall
- Distributed I/O-connections inside or on cabinet wall

For more detailed information, see Chapter 2, Specification of Variants and Options.



**ABB I/O units
(node types)**

Several I/O units can be used. The following table shows the maximum number of physical signals that can be used on each unit. Data rate is fixed at 500 Kbit/s.

Type of unit	DSQC	Option no.	Digital		Analog			Power supply
			In	Out	Voltage inputs	Voltage output	Current output	
Digital I/O 24 VDC	328	61-1	16	16				Internal/External ¹
Digital I/O 120 VAC	320	60-1	16	16				Internal/External
Analog I/O	355	54-1			4	3	1	Internal
AD Combi I/O	327	58-1	16	16		2		Internal/External ¹
Relay I/O	332	63-1	16	16				Internal/External ¹
Allen-Bradley Remote I/O Slave	350	13-1	128 ²	128				
Interbus Slave	351	178-1	64 ²	64				
Profibus DP Slave	352	251-1	128 ²	128				
Simulated I/O ³			150	150	30	30		
Encoder interface unit ⁴	354	79-1	1					
Encoder interface unit ⁵	377	80-1						

1. The digital signals are supplied in groups, each group having 8 inputs or outputs.
2. To calculate the number of logical signals, add 2 status signals for Allen-Bradley Remote I/O unit and 1 for Interbus and Profibus DP.
3. A non physical I/O unit can be used to form cross connections and logical conditions without physical wiring. No. of signals are to be configured. Some Process-Wares include SIM unit. Note that the maximum number of in and out are increased to 200 from RW 4.0.40 and to 512 from RW 4.0.100
4. Dedicated for conveyor tracking only.
5. Only for PickMaster 4.0

1 Description

1.3.2 Operator's panel

Distributed I/O

The maximum number of logical signals is 1024 in total for the CAN/DeviceNet buses (inputs or outputs, group I/O, analog and digital including field buses).

Units	CAN1	CAN2 (option)
Max. total no of units ¹	20 (including SIM units)	20
Data rate (fixed)	500 Kbit/s	125/250/500 Kbit/s
Max. total cable length	100 m trunk + 39m drop	up to 500m
Cable type (not included)	According to DeviceNet specification release 1.2	According to DeviceNet specification release 1.2

1. Max. four units can be mounted inside the cabinet. For IRB 6600/7600 with option 85-2 (+52C) the max. number is three.

Permitted customer load

Load	Value
24 V DC load	max.7,5 A

Digital inputs 24 V DC (option 61-1/58-1/63-1)

Parameter	Value
Optically-isolated	
Rated voltage	24 V DC
Logical voltage levels "1"	15 to 35 V
Logical voltage levels "0"	-35 to 5 V
Input current at rated input voltage	6 mA
Potential difference	max.500 V
Time delays, hardware	5 - 15 ms
Time delays, software	≤ 3 ms
Time variations	± 2 ms

Digital outputs 24 V DC (option 61-1/58-1)

Parameter	Value
Optically-isolated, short-circuit protected, supply polarity protection	
Voltage supply	19 to 35 V
Rated voltage	24 V DC
Logical voltage levels: "1"	18 to 34 V
Logical voltage levels: "0"	< 7 V
Output current	max. 0.5 A
Potential difference	max. 500 V
Time delays: hardware	≤ 1ms

Parameter	Value
Time delays: software	≤2 ms
Time variations	± 2 ms

Relay outputs (option 63-1)

Parameter	Value
Single pole relays with one make contact (normally open)	
Rated voltage	24 V DC, 120 V AC
Voltage range	19 to 35 V DC 24 to 140 V AC
Output current	max.2 A
Potential difference	max.500V
Time intervals	hardware (set signal) typical 13 ms
Time intervals	hardware (reset signal) typical 8 ms
Time intervals	software ≤ 4 ms

Digital inputs 120 V AC (option 60-1)

Parameter	Value
Optically isolated	
Rated voltage	120 V AC
Input voltage range: "1"	90 to 140 V AC
Input voltage range: "0"	0 to 45 V AC
Input current (typical):	7.5 mA
Time intervals	hardware ≤ 20 ms
Time intervals	software ≤ 4 ms

Digital outputs 120 V AC (option 60-1)

Parameter	Value
Optically isolated, voltage spike protection	
Rated voltage	120 V AC
Output current	max. 1A/channel, 12 A 16 channels
Output current	max. 2A/channel, 10 A 16 channels (56 A in 20 ms)
Output current	min. 30mA
Voltage range	24 to 140 V AC
Potential difference	max. 500 V
Off state leakage current	max. 2mA rms
On state voltage drop	max. 1.5 V
Time intervals	hardware ≤ 12 ms

1 Description

1.3.2 Operator's panel

Parameter	Value
Time intervals	software \leq 4 ms

Analog inputs (option 54-1)

Parameter	Description	Value
Voltage	Input voltage	\pm 10 V
Voltage	Input impedance	$>$ 1 Mohm
Voltage	Resolution	0.61 mV (14 bits)
Accuracy		\pm 0.2% of input signal

Analog outputs (option 54-1)

Parameter	Description	Value
Voltage	Output voltage	\pm 10 V
Voltage	Load impedance	min. 2 kohm
Voltage	Resolution	2.44 mV (12 bits)
Current	Output current	4-20 mA
Current	Load impedance	min. 800 ohm
Current	Resolution	4.88 μ A (12 bits)
Accuracy		\pm 0.2% of output signal

Analog outputs (option 58-1)

Parameter	Value
Output voltage galvanically isolated	0 to +10 V
Load impedance	min. 2 kohm
Resolution	2.44 mV (12 bits)
Accuracy	\pm 25 mV \pm 0.5% of output voltage
Potential difference	max. 500 V
Time intervals	hardware \leq 2.0 ms
Time intervals	software \leq 4 ms

System signals

Signals can be assigned to special system functions. Several signals can be given the same functionality.

Digital outputs	Digital inputs	Analog output
Motors on/off	Motors on/off	TCP speed signal
Executes program	Starts program from where it is	
Error	Motors on and program start	
Automatic mode	Starts program from the beginning	
Emergency stop	Stops program	
Restart not possible	Stops program when the program cycle is ready	
Run chain closed	Stops program after current instruction	
	Executes "trap routine" without affecting status of stopped regular program ¹	
	Loads and starts program from the beginning ¹	
	Resets error	
	Resets emergency stop	
	System reset	

1. Program can be decided when configuring the robot.



For more information on system signals, see User's Guide - System Parameters

1 Description

1.3.2 Operator's panel

1.14 Communication

General

The controller has three serial channels for permanent use – two RS232 and one RS422 Full duplex – which can be used for communication point to point with printers, terminals, computers and other equipment. For temporary use, like service, there are two more RS 232 channels.

The serial channels can be used at speeds up to 19,200 bit/s (max. 1 channel with speed 19,200 bit/s).

The controller has two Ethernet channels and both can be used at 10 Mbit/s or 100 Mbit/s. The communication speed is set automatically.

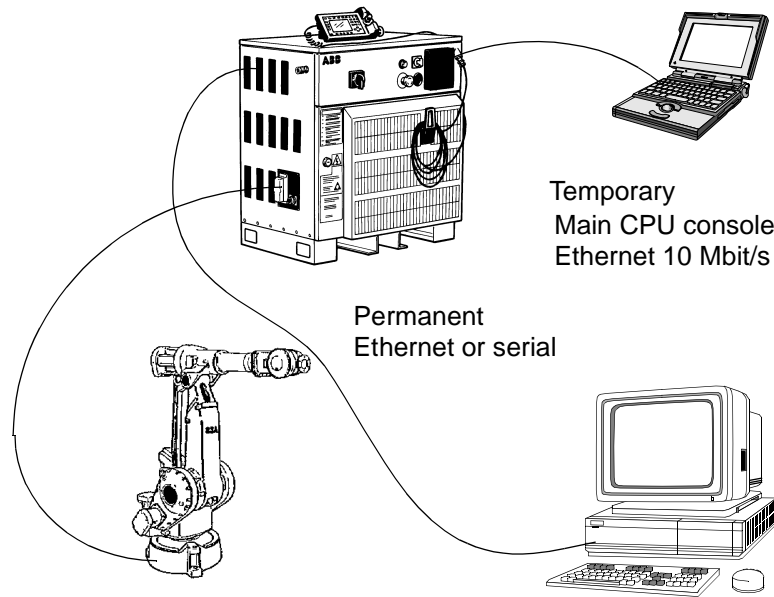

Figure 14 Point-to-point communication.

The communication includes TCP/IP with intensive network configuration possibilities like:

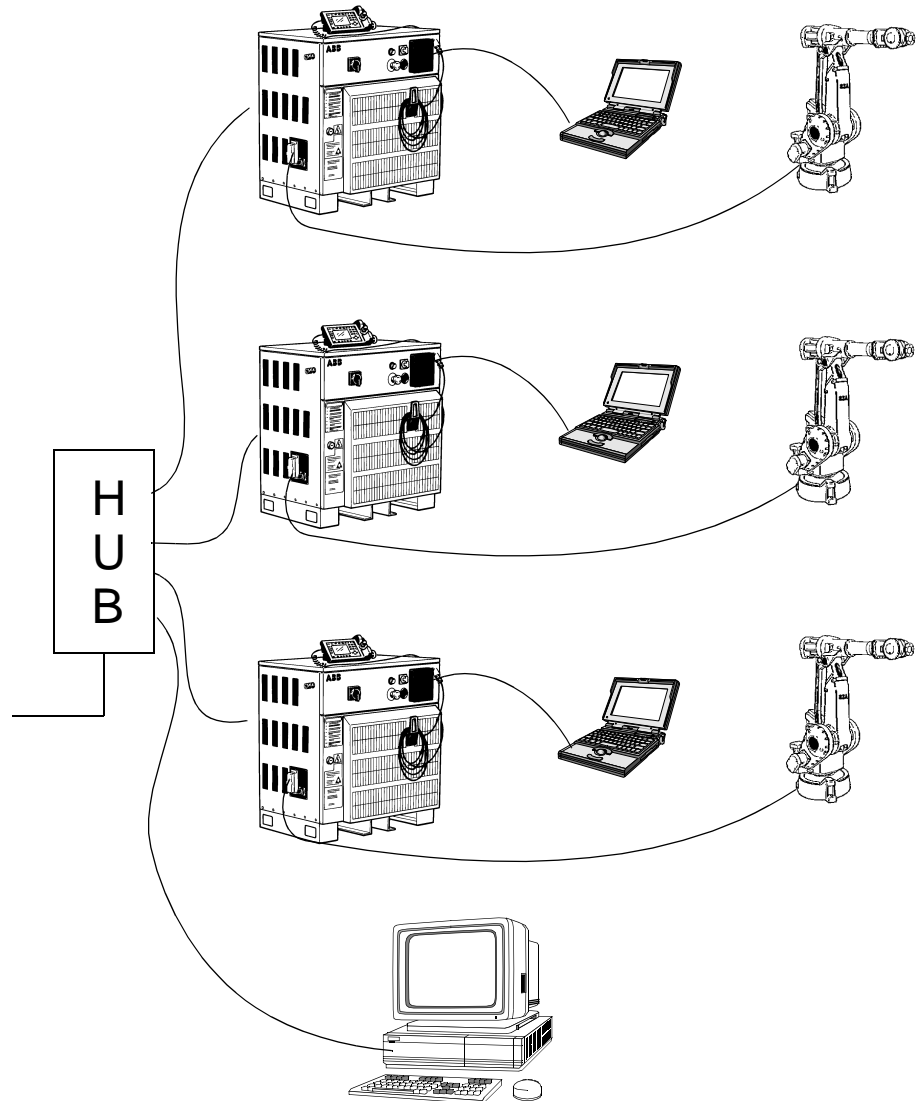

Figure 15 Network (LAN) communication.

Configuration	Description
DNS, DHCP etc.	Inclusion of multiple gateway
Network File System	Accesses using FTP/NFS client and FTP server
Control and/or monitoring of controllers with RAP protocol	Possibility to use OPC, ActiveX, and other APIs for integration with Windows applications
Boot/upgrading of controller software	Via the network or a portable PC

1 Description

1.3.2 Operator's panel

2 Specification of Variants and Options

2.1 Introduction

General

The different variants and options for the controller are described below.

The same numbers are used here as in the Specification form.

For manipulator options, see Product Specification respectively, and for software options, see Product Specification RobotWare Options.

2.2 Safety Standards

EU - Electromagnetic Compatibility

Option	Description
129-1	The controller complies with the European Union Directive "Electromagnetic Compatibility" 89/336/EEC. This option is required by law for end users in the European Union. Not available for controllers connected to 600 V.

Underwriters Laboratories Inc.

Option	Description
429-1UL/CSA	The robot is certified by Underwriters Laboratory to comply with the Safety Standard ANSI/UL 1740-1996 "Industrial Robots and Robotic Equipment" and CAN/CSA Z 434-94. UL/UR certification is required by law in some US states and Canada. UL (UL/CSA) means certification of complete product and UR (UL recognized Component) means certification of component or not complete product. Safety lamp (213-1) Door interlock (188-1, 207-1 or 207-8) Operating mode selector standard 2 modes (241-1) are mandatory. Cabinet height 950 mm without upper cover (64-5), Cabinet height 1200 mm (64-1) Cabinet height 1750 mm (64-3), Cabinet variant Prepared for Arcitec (66-1), Mains connection type CEE17 connector (206-3, 206-2), Service outlet type 230V Europe (328-1).
429-2 UR(UL Recognized)	The robot is certified by Underwriters Laboratories Inc. to comply with the Safety Standard UL 1740 "Industrial Robots and Robotic Equipment". UL/UR certification is required by law in some US states and Canada. UL (UL listed) means certification of complete product and UR (UL Recognized Component) means certification of component or not complete product. Safety lamp (213-1), Door interlock (188-1 or 207-1), Operating mode selector standard 2 modes (241-1) are mandatory. Not with Cabinet variant Prepared for Arcitec (66-1), Mains connection type CEE17 connector (206-3, 206-2), Service outlet type 230V Europe (328-1).

2.3 Control System

Cabinet

Variants

Option	Description
66-2	Standard cabinet with upper cover.
66-1	Prepared for Arcitec Rotary switch 80A (207-5) and Circuit breaker standard (70-2) and Arcitec 4.0 (18-1) are mandatory. Not with Wheels (67-1) or Mains connection type CEE17 connector (206-3, 206-2) or 6HSB (206-4) or Mains switch Flange disconnecter (207-1) or Servo disconnecter (320-1) or UL (429-1) or UR (429-2).

Cabinet Height

Wheels are not included in height

Option	Description
64-4	Standard cabinet 950 mm with upper cover.
64-5	Standard cabinet 950 mm without upper cover. To be used when cabinet extension is mounted on top of the cabinet after delivery. Not with Door interlock (188-1) or UL (429-1) or UR (429-2).
64-1	Standard cabinet with 250 mm extension. The height of the cover increases the available space for external equipment that can be mounted inside the cabinet. Not with UL (429-1).
64-3	Standard cabinet with 800 mm extension. The extension is mounted on top of the standard cabinet. There is a mounting plate inside. (See Figure 16). The cabinet extension is opened via a front door and it has no floor. The upper part of the standard cabinet is therefore accessible. Not with UL (429-1).

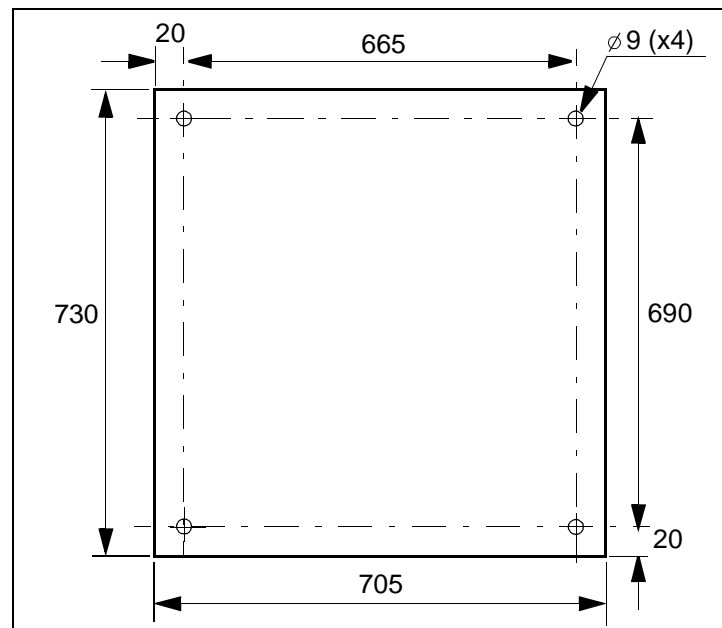

Figure 16 Mounting plate for mounting of equipment (dimensions in mm).

Cabinet on wheels

Option	Description
67-1	Cabinet on wheels. Increase the height by 30 mm. Not with Prepared for Arcitec (66-1).

Operator's panel

The operator's panel and teach pendant holder can be installed in different ways.

Option	Description
242-6	Standard, i.e. on the front of the cabinet.
242-1	External, i.e. in a separate operator's unit. (See Figure 17 for required preparation) All necessary cabling, including flange, connectors, sealing strips, screws, etc., is supplied. External enclosure is not supplied.
242-4	External, mounted in a box. (See Figure 18)

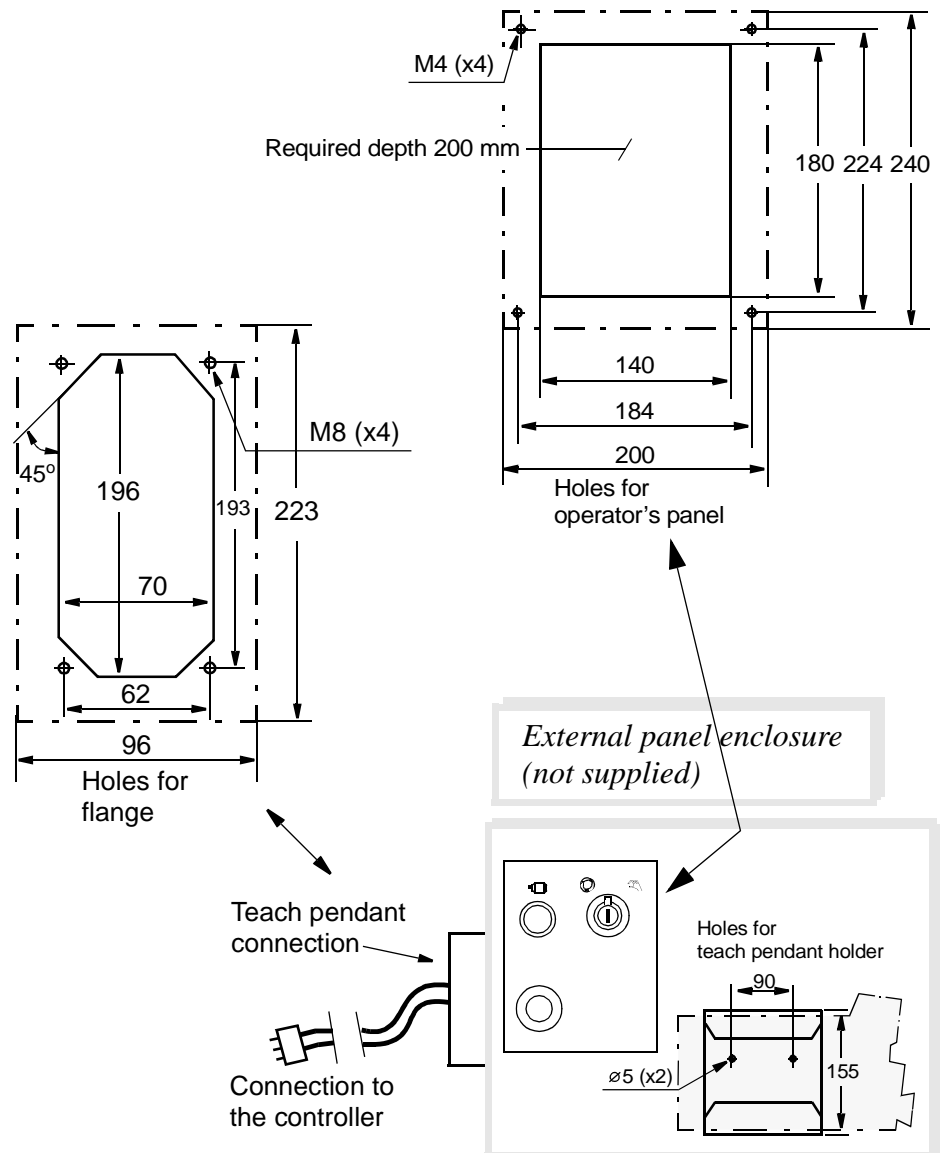

Figure 17 Required preparation of external panel enclosure (all dimensions in mm).

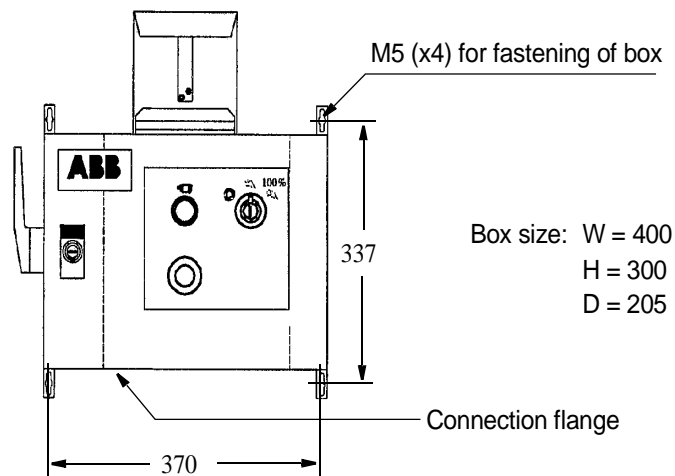

Figure 18 Operator's panel mounted in a box (all dimensions in mm).

Operator's panel cable

Option	Length
240-1	15 m
240-2	22 m
240-3	30 m

Door lock insert

Option	Description
65-6	Standard
65-1	Doppelbart
65-5	Square outside 7 mm
65-2	EMKA DB
65-4	Locking cylinder 3524

Operating mode selector

Option	Description
241-1	Standard, 2 modes: manual and automatic.
241-2	Standard, 3 modes: manual, manual full speed and automatic. Does not comply with UL and UR safety standards.

2 Specification of Variants and Options

Controller cooling

Option	Description
85-1	Ambient temperature up to 45°C (113°F) Standard design. The computer unit is provided with a passive heat exchanger (cooling fins on the rear part of the box).
85-2	Ambient temperature up to 52°C (125°F). The computer unit is provided with an active Peltier cooling equipment (replaces the cooling fins from option 85-1).

Teach Pendant

Option	Description
370-1	Teach pendant with back lighting, connection cable 10 m.

Option	Teach Pendant Language
413-1	English
419-1	Swedish
416-1	German
415-1	French
420-1	Spanish
411-1	Danish
417-1	Italian
412-1	Dutch
410-1	Czech
414-1	Finnish

Extension cable for the teach pendant

Option	Length	Description
373-1	10 m	An extension cable can be connected between the controller and the teach pendant. The total length of cable between the controller and the teach pendant should not exceed 40 m. Note that the length of the optional operator's panel cable must be included in the limitation.
373-2	20 m	

Mains voltage

The control system can be connected to a rated voltage of between 200 V and 600 V, 3-phase and protective earthing. A voltage fluctuation of +10% to -15% is permissible.

**IRB 6600,
IRB 6650,
IRB 7600**

Option	Voltage	Description
208-1	200V	External transformer is supplied, see Figure 19
208-2	220V	External transformer is supplied, see Figure 19
208-3	400V	
208-4	440V	
208-5	475V	
208-7	500V	
208-8	525V	
208-9	600V	

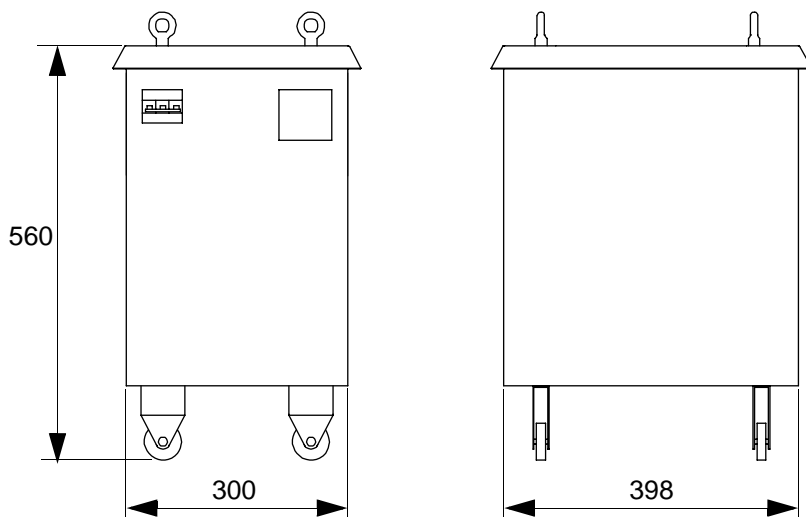

Figure 19 Transformer unit (dimensions in mm).

**IRB 140,
IRB 1400,
IRB 2400,
IRB 4400,
IRB 6400,
IRB 340, IRB 640,
IRB 940**

Option	Voltage
208-1	200V
208-2	220V
208-3	400V
208-4	440V
208-5	475V
208-7	500V
208-8	525V
208-9	600V

2 Specification of Variants and Options

In addition to above selection, the voltage range has to be specified. This gives the possibility to select between three different transformers.

Option	Voltage range	Market
442-1	Voltage range 200, 220, 400, 440V	Intended for the Asian market
442-2	Voltage range 400, 440, 475, 500V	Intended for the European market
442-3	Voltage range 475, 500, 525, 600V	Intended for the North American market

Mains connection type

The power is connected either inside the cabinet or to a connector on the cabinet's left-hand side. The cable is not supplied. If option 206-2--4 is chosen, the female connector (cable part) is included.

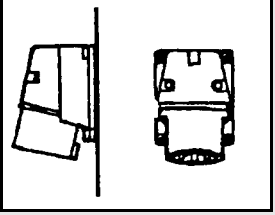
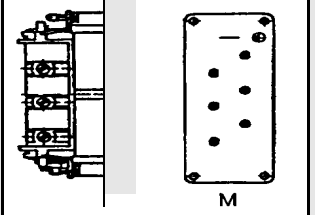
Option	Description
206-1	<p>Cable gland for inside connection. Diameter of cable:11-12 mm. Figure 20 CEE male connector</p> 
206-3	CEE17-connector 32 A, 380-415 V, 3p + PE (see Figure 20). Not with Flange disconnecter (207-1) or UL/UR (429-1/429-2) or Service outlet power supply (331-2). Not available for IRB 6600/7600.
206-2	32 A, 380-415 V, 3p + N + PE (see Figure 20). Not with Flange disconnecter (207-1) or UL/UR (429-1/429-2). Not available for IRB 6600/7600.
206-4	<p>Connection via an industrial Harting 6HSB connector in accordance with DIN 41640. 35 A, 600 V, 6p + PE (see Figure 21). Cannot be combined with Flange disconnecter (207-1). Figure 21 DIN male connector</p> 

Mains switch

Option	Description
207-4	Rotary switch 40 A in accordance with the standard in section 1.2 and IEC 337-1, VDE 0113. Customer fuses for cable protection required.
207-1	Flange disconnecter in accordance with the standard in section 1.2. Includes door interlock for flange disconnecter and a 20A circuit breaker with interrupt capacity 14 kA.
207-8	Flange disconnecter in accordance with the standard in section 1.2. Includes door interlock for flange disconnecter and a 20A circuit breaker with interrupt capacity 65 kA at 400V, 25 kA at 600V.
207-5	Rotary switch 80 A. Customer fuses for cable protection required. Included in the option Prepared for Arcitec (66-1).
320-1	Servo disconnecter. This option adds a rotary switch 40 A to the two contactors in the AC power supply for the drive system. The handle can be locked by a padlock, e.g. in an off position.
188-1	Door interlock for rotary switch. Included in the options UL/CSA/UR (429-1, 429-2) and Servo disconnecter (320-1).
70-2	Circuit breaker for rotary switch. Rated current 16A (option 442-2, -3) or 25A (option 442-2) circuit breaker for short circuit protection of mains cables in the cabinet. Circuit breaker approved in accordance with IEC 898, VDE 0660. Interrupt capacity 30 kA at 400V.

For IRB 7600 and IRB 6600 the cabinet circuit breaker is always rated 25A.

When an external transformer is supplied, the circuit breaker is located in the transformer.

I/O Interfaces

The standard cabinet can be equipped with up to four I/O units. For more details, see *I/O System* on page 33.

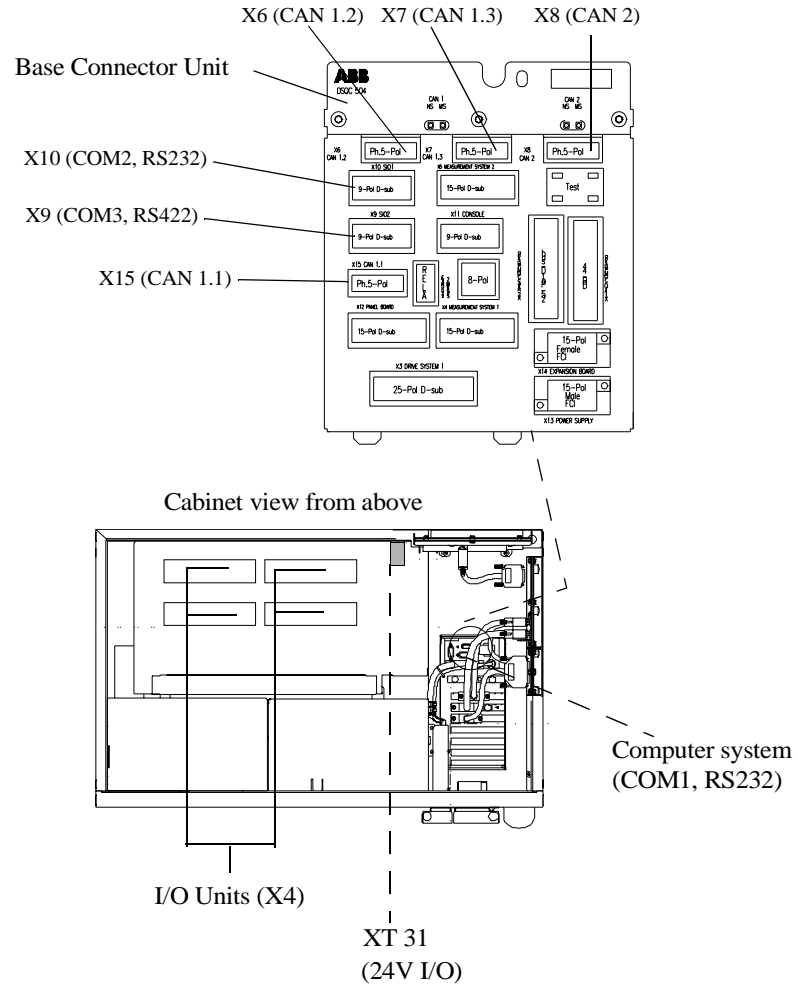

Figure 22 I/O unit and screw terminal locations.

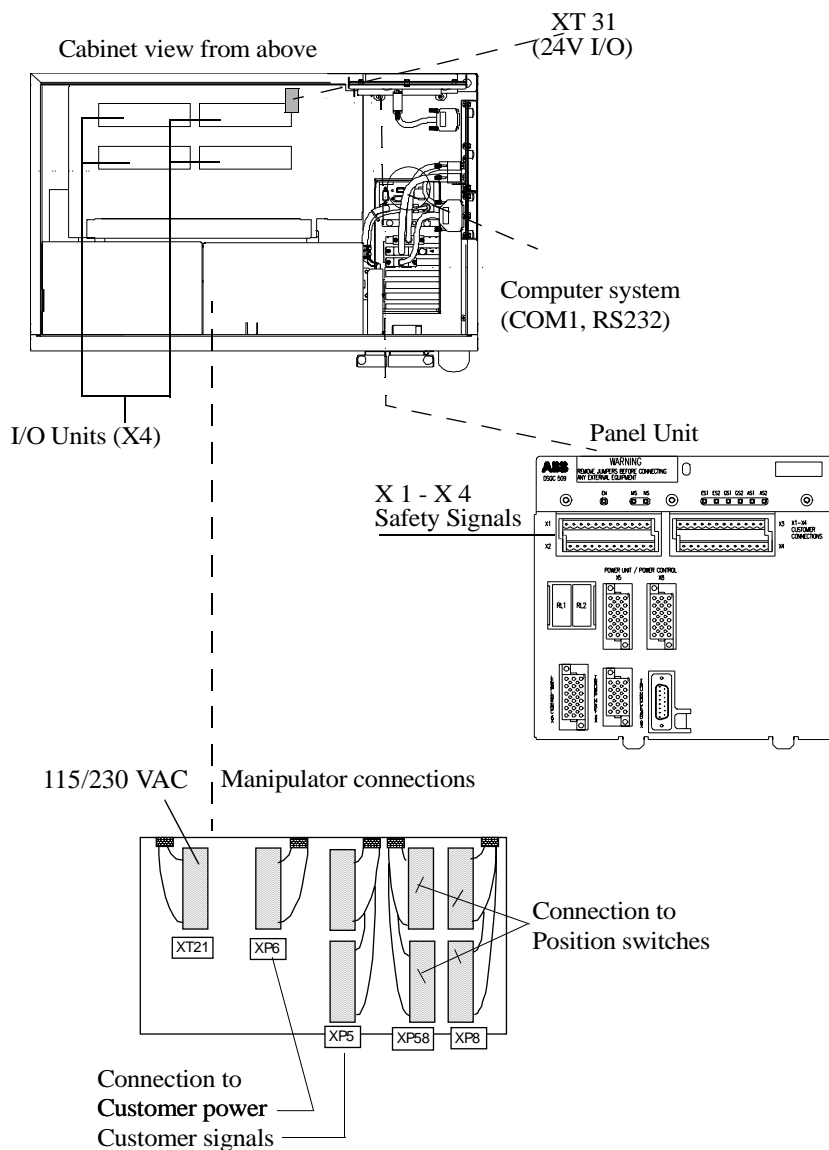

Figure 23 I/O unit and screw terminal locations.

Inputs/outputs

Option	Inputs/outputs	Description
61-1	Digital 24 VDC I/O	16 inputs/16 outputs
54-1	Analog I/O	4 inputs/4 outputs
58-1	AD Combi I/O	16 digital inputs/16 digital outputs and 2 analog outputs (0-10V)
60-1	Digital 120 VAC I/O	16 inputs/16 outputs
63-1	Digital I/O with relay outputs	16 inputs/16 outputs. Relay outputs to be used when more current or voltage is required from the digital outputs. The inputs are not separated by relays.

2 Specification of Variants and Options

Connection of I/O

Option	Connection	Description
191-3	Internal connection (options 61-1, 54-1, 58-1, 60-1, 63-1)	The signals are connected directly to screw terminals on the I/O units in the upper part of the cabinet (see Figure 23).
191-2	External connection	The signals are connected via 64-pole standard industrial connector in accordance with DIN 43652. The connector is located on the left-hand side of the controller. Corresponding customer part is included.
225-1	Prepared for 4 I/O units	The internal CAN/Devicenet cabling to the I/O units exists in two versions, one for up to two I/O units and one for up to four I/O units. The versions are selected to match the number of ordered I/O units. By this option it is possible to get the four unit version even if one or two I/O units are ordered.

Safety signals

Option	Connection	Description
309-3	Internal connection	The signals are connected directly to screw terminals in the upper part of the cabinet (see Figure 23).
309-2	External connection	The signals are connected via 64-pole standard industrial connector in accordance with DIN 43652. The connector is located on the left-hand side of the controller. Corresponding customer part is included.

Field bus and communication

Option	Connection	Description
108-1	CAN/DeviceNet	Connection on the left side to two 5-pole female connectors in accordance with ANSI. (Male connectors are supplied).
126-1	LAN/Ethernet	RJ45 connector to be used for LAN connector. (When the connector is not used, a protective hood covers it).

Option		Description
250-1	Profibus DP Master/Slave	<p>The hardware of the Profibus-DP field bus consists of a master/slave unit, DSQC 510, and distributed I/O units, called slave units. The DSQC 510 unit is mounted in the S4Cplus computer system where it is connected to the PCI bus while the slave units are attached to the field bus network.</p> <p>The slave units can be I/O units with digital and/or analogue signals. They are all controlled via the master part of the DSQC 510 unit.</p> <p>The slave part of the DSQC 510 is normally controlled by an external master on a separate Profibus-DP network. This network is a different one than the network holding the slave units for the master part of the board. The slave part is a digital input and output I/O unit with up to 512 digital input and 512 digital output signals.</p> <p>The signals are connected to the board front (two 9-pole D-sub). Profibus DP M/S CFG Tool (option 285-1) is required when setting up the master part or when changing the number of signals for the slave part. For more information see Product Specification RobotWare Options.</p>
177-3/177-1	Interbus Master/Slave	<p>The hardware of the Interbus field bus consists of a Master/Slave unit (DSQC512/529) and distributed I/O units. The master and the slave units are two separate boards connected by a flat cable. The DSQC512/529 unit is connected to the S4Cplus robot controller PCI bus while the I/O units are attached to the field bus net.</p> <p>The I/O units may be digital or analog modules. They are all controlled by the master part of the DSQC512/529 unit.</p> <p>The slave part of the DSQC512/529 unit is normally controlled by an external master on a separate Interbus network. This network is a different one than the network holding the I/O units for the master part of the board. The slave part is a digital in- and out put I/O unit with up to 160 digital in- and 160 digital out signals.</p>

Variants

Two variants are available

Option	Variants
177-3	for optical fibre connection (DSQC512)
177-1	for copper wire connection (DSQC529)

2 Specification of Variants and Options

Interbus M/S CFG Tool (option 185-1) is required when setting up the master part or when changing the number of signals for the slave part. For more information see Product Specification RobotWare Options.

Gateway units

For more details, see *I/O System* on page 33.

Option		Description
13-1	Allen-Bradley Remote I/O	Up to 128 digital inputs and outputs, in groups of 32, can be transferred serially to a PLC equipped with an Allen Bradley 1771 RIO node adapter. The unit reduces the number of I/O units that can be mounted in cabinet by one. The field bus cables are connected directly to the A-B Remote I/O unit in the upper part of the cabinet (see Figure 23). Connectors Phoenix MSTB 2.5/xx-ST-5.08 or equivalent are included.
178-1	Interbus Slave	Up to 64 digital inputs and 64 digital outputs can be transferred serially to a PLC equipped with an InterBus interface. The unit reduces the number of I/O units that can be mounted in the cabinet by one. The signals are connected directly to the InterBus slave unit (two 9-pole D-sub) in the upper part of the cabinet.
251-1	Profibus DP Slave	Up to 128 digital inputs and 128 digital outputs can be transferred serially to a PLC equipped with a Profibus DP interface. The unit reduces the number of I/O units that can be mounted in the cabinet by one. The signals are connected directly to the Profibus DP slave unit (one 9-pole D-sub) in the upper part of the cabinet.
79-1	Encoder interface unit for conveyor tracking (DSQC 354)	Conveyor Tracking, RobotWare option 83-1, is the function whereby the robot follows a work object which is mounted on a moving conveyor. The customer encoder and synchronization switch cables are connected directly to the encoder unit in the upper part of the cabinet (see Figure 23). Screw connector is included. This option is also required for the function Sensor Synch, RobotWare option 316-1.
80-1	Encoder interface unit for conveyor tracking (DSQC 377)	The option adds functions required for PickMaster 4.0. Physically similar to DSQC 354.

External I/O units

I/O units can be delivered separately. The units can then be mounted outside the cabinet or in the cabinet extension. These are connected in a chain to a connector (CAN 3 or CAN 2, see Figure 23) in the upper part of the cabinet. Connectors to the I/O units and a connector to the cabinet (Phoenix MSTB 2.5/xx-ST-5.08), but no

cabling, is included. Dimensions according to Figure 24 and Figure 25.
For more details, see *I/O System* on page 33.

Option		Inputs/outputs
137-1	Digital I/O 24 V DC	16 inputs/16 outputs
132-1	Analog I/O	
130-1	AD Combi I/O	16 digital inputs/16 digital outputs and 2 analog outputs (0-10V)
136-1	Digital I/O 120 V AC	16 inputs/16 outputs
138-1	Digital I/O with relay outputs	16 inputs/16 outputs

External gateway units

Option	Units
131-1	Allen Bradley Remote I/O
142-1	Interbus Slave
144-1	Profibus DP Slave
134-1	Encoder interface unit DSQC 354
135-1	Encoder interface unit DSQC 377

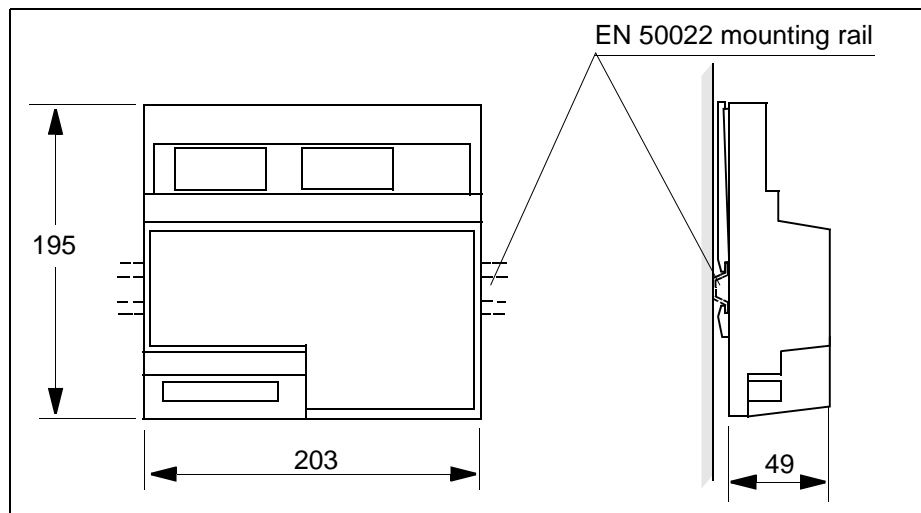

Figure 24 Dimensions for I/O units.

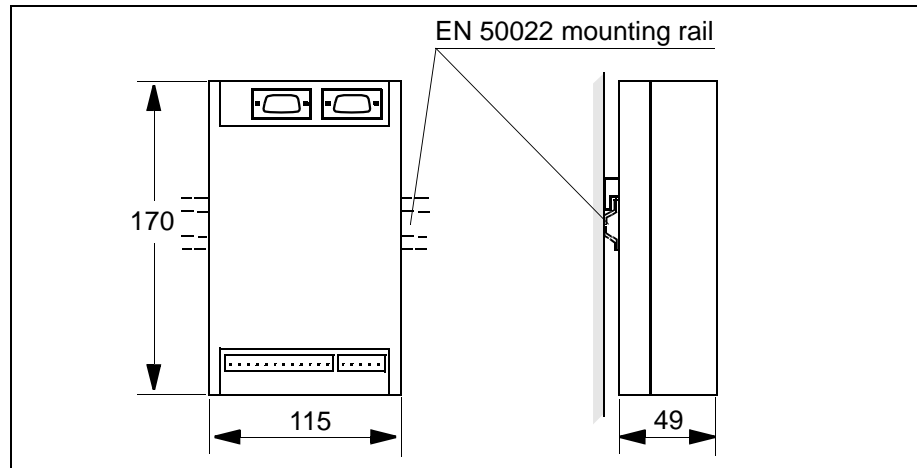

Figure 25 Dimension for gateway units.

External axes in robot cabinet



not available for IRB 340, IRB 6400PE, IRB 6600, IRB 7600

It is possible to equip the controller with drives for external axes. The motors are connected to a standard industrial 64-pin female connector, in accordance with DIN 43652, on the left-hand side of the cabinet. (Male connector is also supplied.)

Drive units

Option	Units	Description
52-1	Drive unit C	The drive unit is part of the DC-link. Recommended motor type, see <i>Motor selection table</i> on page 64 Not available for IRB 640.
52-7	Drive unit T	The drive unit is part of the DC-link. Recommended motor type, see <i>Motor selection table</i> on page 64 Not available for IRB 640, 6400R.
52-9	Drive unit U	The drive unit is part of the DC-link. Recommended motor types, see <i>Motor selection table</i> on page 64 Not available for IRB 4400, 6400S, 6400PE, 640. For IRB 140, 1400 and 2400 the option consists of a larger transformer, DC link DC4U with integrated U drive unit and one extra axis computer with its connection board. No cabling from the drive unit U to cabinet wall is included. For IRB 6400R the option consists of a DC link DC4U with integrated U drive unit with cabling to the cabinet wall.

Option	Units	Description
52-3	Drive unit GT	A separate drive unit including two drives. Recommended motor type, see <i>Motor selection table</i> on page 64 Not available for IRB 4400, 6400R, 6400S
52-4	Prepared for drives GT	The same as 52-3 but without the GT drive module. The preparation includes; larger transformer, larger DC link DC2, and one additional axis computer with its connection board. Not available for IRB 4400, 640, 6400R, 6400S
52-6	Prepared for drives GT	The same as 52-4 but without additional axes computer and connection board.
52-5	Prepared for drives GU	The same as 52-4 but intended for a GU drive module. The preparation includes: larger transformer, larger DC link DC4, and one additional axis computer with its connection board. Not available for IRB 4400, 640, 6400R, 6400S.
52-8	Drive unit T+GT	A combination of 52-7 and 52-3. Not available for IRB 4400, 640, 6400R, 6400S
52-2	Drive unit C+GT	A combination of 52-1 and 52-3 Not available for IRB 4400, 640, 6400R, 6400S
422-1	Track Motion	A special wiring for the three motor combination 52-8 (IRB 140, 1400, 2400 only) to be used when axis 7 is intended for an ABB Track Motion. The drive unit in the DC link and the Track Motion measurement board is then connected to the robot axes computer 1 while the drive unit and the measurement board for motor 8 and 9 is connected to axes computer 2. All motor power wiring is routed to one common connector, XS7.

Servo gun interface

Option	Robot	Description
323-1--6	IRB 6400R, IRB 6600 and 7600	For further information see the Product Specification IRB 6400R chapter Servo Gun or IRB 6600 chapter Servo Gun (overview), and the Product Specification RobotWare Options (function description).

Stationary gun (SG)

Option	Robot	Description
323-5 Stationary gun (SG) or one external axis for general use	IRB 6400R	The option consists of an encapsulated Serial Measurement Board (SMB) and cabling inside the controller. The cabling between SMB and the controller is selected in the option range 95-1--4. Drive unit 52-9 is required.

2 Specification of Variants and Options

Option	Robot	Description
323-5 Stationary gun (SG) or one external axis for general use	IRB 6600/7600	<p>The option adds a resolver cable to the manipulator cable option 476-1 (or 467-1), and a 7m resolver cable between the manipulator and the welding gun pedestal. The customer connector to this cable should be an 8-pin Burndy, wired according to Motor Unit specification.</p> <p>The cable between the controller DDU and the welding gun pedestal is selected in the option range 95-1, -2, -4 (different lengths). The customer connector to this cable should be of Industrial Multi-connector type, corresponding to the manipulator CP/CS (see Product Specification IRB 6600/7600). Besides the necessary motor wiring, it also contains 12 wires for gun I/O, accessible on screw terminals in the cabinet. Drive unit 53-2 or 53-3 (DDU-V or -W) must be selected.</p>

Robot Gun (RG)

Option	Robot	Description
323-1 Robot Gun (RG)	IRB 6400R	<p>The option consists of an encapsulated SMB and cabling inside the controller. It also includes bracket for 6400R foot mounting of the SMB box, and cabling between the SMB box and the manipulator.</p> <p>The cabling between SMB and the controller is selected in the option range 93-1--4.</p> <p>Drive unit option 52-9 is required.</p>
323-1 Robot Gun (RG)	IRB 6600/7600	<p>The option adds resolver cables to the manipulator cable option 476-1. The cable between the controller and the manipulator is selected in the option range 450-1, -2, -4. Besides the necessary motor wiring the cable also contains 22 wires for gun I/O and CAN/DeviceNet fieldbus. The I/O wiring is accessible on screw terminals in the cabinet.</p> <p>Drive unit 53-2 (DDU-V) must be selected.</p>

One SG and one RG

Option	Robot	Description
323-3	IRB 6400R	<p>The option is a combination of 523-5 and 523-1. A distributed drive unit (DDU) controls the SG motor.</p> <p>The cabling between the SG SMB and the controller is selected in the option range 95-1--4, and the cabling between the RG SMB and the controller is selected in the option range 93-1--4.</p> <p>Drive unit options 52-9 (for the RG) and 53-1 (for the SG) are required.</p>

Option	Robot	Description
323-3	IRB 6600/7600	<p>The option adds a resolver cable to the manipulator cable option 476-1. The cable between the controller and the welding gun pedestal is selected in the option range 95-1--4. The customer connector to this cable should be of Industrial Multi-connector type, corresponding to the manipulator CP/CS (see Product Specification IRB 6600/7600). Besides the necessary motor wiring it also contains 12 wires for gun I/O, accessible on screw terminals in the cabinet.</p> <p>The cable between the controller and the manipulator (for RG) is selected in the option range 450-1, -2, -4. Besides the necessary motor wiring the cable also contains 22 wires for gun I/O and CAN/DeviceNet fieldbus.</p> <p>The option also consists of an SMB box for two resolvers, a serial cable between the box and the controller (the same length as 210-2--5), and two resolver cables, one 1.5m for the RG and one 7m for the SG. The customer connector to the SG cable should be an 8-pin Burndy, wired according to the Motor Unit specification. The SMB box should be mounted close to the manipulator foot. Dimensions and mounting information can be found in the Product Specification Motor Unit.</p> <p>Drive unit 53-4 (DDU-VW) must be selected.</p>

Twin SG

Option	Robot	Description
323-6 Twin SG	IRB 6400R	<p>The option is a combination of two options 323-5. A distributed drive unit controls the second SG motor. The cabling between the SG SMBs and the controller is selected in the option range 95-1--4.</p> <p>Drive unit options 52-9 (for one SG) and 53-1 (for the second SG) are required.</p>
323-6 Twin SG	IRB 6600/7600	<p>The option consists of an SMB box for two resolvers, a serial cable between the box and the controller (the same length as 686-689), and two 7m resolver cables. The customer connector to the SG cable should be an 8-pin Burndy, wired according to the Motor Unit specification. The SMB box should be mounted close to the manipulator foot. Dimensions and mounting information can be found in the product Specification Motor Unit.</p> <p>The two cables between the controller and the pedestals are selected in the option range 95-1--2.</p> <p>Customer connectors to the cables should be of Industrial Multi-connector type, corresponding to the manipulator CP/CS (see Product Specification IRB 6600/7600). Besides the necessary motor wiring, the cables also contain 12 wires for gun I/O, accessible on screw terminals in the cabinet (SG axis 7), or on the Multi connector inside (SG axis 8) the DDU.</p> <p>Drive unit 53-4 (DDU-VW) must be selected.</p>

2 Specification of Variants and Options

SG and Track Motion

Option	Robot	Description
323-4 SG and Track Motion (T)	IRB 6400R	<p>The option is a combination of 323-5 and a Track Motion IRBT 6002S controlled by a distributed drive unit.</p> <p>The cabling between the SG SMB and the controller is selected in the option range 95-1--4.</p> <p>Drive unit options 52-9 (for the SG) and 53-1 (for the T) are required.</p>
323-4 SG and Track Motion (T)	IRB 6600/7600	<p>A 7m resolver cable for the SG is included in the option. The customer connector to the cable should be an 8-pin Burndy, wired according to the Motor Unit specification.</p> <p>The cable between the controller and the welding gun pedestal is selected in the option range 95-1--2.</p> <p>The customer connector to the cable should be of Industrial Multi-connector type, corresponding to the manipulator CP/CS (see Product Specification IRB 6600/7600). Besides the necessary motor wiring the cable also contains 12 wires for gun I/O, accessible on screw terminals in the cabinet.</p> <p>The SMB box and the power cable between the controller and the Track Motion are included in the Track Motion delivery. The serial measurement cable between the controller and the Track Motion are included in option 323-4 (length according to 210-2, -3).</p> <p>Drive unit 53-4 (DDU-VW) must be selected.</p>

RG and T

Option	Robot	Description
323-2 RG and T	IRB 6400R	<p>The option is a combination of 323-1 and a track motion IRBT 6002S controlled by a distributed drive unit.</p> <p>The cabling between the RG SMB and the controller is selected in the option range 93-1--4.</p> <p>Drive unit options 52-9 (for the SG) and 53-1 (for the T) are required.</p>
323-2 RG and T	IRB 6600/7600	<p>The option adds a resolver cable to the manipulator cable option 2200. The RG cable between the controller and Track Motion is selected in the option range 450-1, -2, -4 except for the track motor cable which is included in the Track Motion delivery.</p> <p>Besides the necessary motor wiring, the RG cable also contains 22 wires for gun I/O and CAN/DeviceNet fieldbus.</p> <p>The option also consists of a 1.5m resolver cable for the RG to be connected to the Track Motion mounted SMB box.</p> <p>Drive unit 53-4 (DDU-VW) must be selected.</p>

External axes measurement board



not available for IRB 340, IRB 6400PE

The resolvers can be connected to a serial measurement board outside the controller.

Option	Description
317-2	Serial measurement board as separate unit

External axes - separate cabinet



Low voltage

not available for IRB 340, IRB 6400PE

An external cabinet can be supplied when there is not space enough in the standard cabinet. The external cabinet is connected to one Harting connector (cable length 7 m) on the left-hand side of the robot controller.

Door interlock, mains connection, mains voltage and mains filter according to the robot controller. One transformer and one mains switch are included.

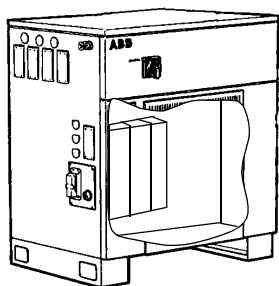

Figure 26

2 Specification of Variants and Options

Recommended motor types see table Motor selection below.

Option	Drive unit	Description
53-7/53-9	Drive unit GT	For 4 or 6 motors
53-5	Drive unit ECB	For 6 motors
53-6	Drive unit GT + ECB	For 5 motors
53-8	Drive unit GT + GT + ECB	For 6 motors

Motor selection table

Motor types according to Product Specification Motor Unit.

Drive voltage	Drive unit identity	Motor max current A_{rms}	Drive unit rated current A_{rms}	Suitable motor type
High	W	11.5-57	30	MU30
High	V	5.5-26	14.5	MU20
Low	U	11 - 55	24	MU30
Low	T	7.5-37	20	MU30
Low	G	6-30	16	MU20
Low	E	4 - 19	8,4	MU20
Low	C	2,5 - 11	5	MU10
Low	B	1,5 - 7	4	MU10

Drive unit

Option	Drive unit	Description
53-1	Drive unit DDU-U (low voltage)	A separate box (H=500mm W=300mm D=250mm) including a DC link DC4 and a drive unit GU where the U part is used (the G part is not connected). The DDU-U is operated from an additional axis computer, included in the option. DDU-U is mainly intended for Servo Gun solutions according to options 323-3, -4, -6 and is available for IRB 4400 and 6400R.
53-2	Drive unit DDU-V	IRB 6600/7600
53-4	Drive unit DDU-VW	IRB 6600/7600
53-3	Drive unit DDU-W	IRB 6600/7600



Figure 27

Drive unit DDU-VW/DDU-V/DDU-W

A separate box (H=500mm, W=300mm, D=250mm) including a DC link DC5 and a drive unit VW.

The box has 4 keyholes on the back of the encapsulation for fastening on a wall or a fence with the connections pointing downwards. Connection cabling (length 5m) to the controller is included.

The DDU-VW is operated from an additional axis computer included in the option, while the DDU-V and -W are operated from the basic robot axes computer.

The options also include appropriate cabling inside the manipulator for different resolver configurations, see Product Specification IRB 6600, chapter Servo Gun. E.g. 7 axes applications utilise the built in 7 resolver SMB.

The DDU-V and VW are mainly intended for Servo Gun solutions according to options 323-1--6.

The DDU-W is intended for a Track Motion without ServoGun.



Figure 28

For general use of one external axis in IRB 6600 or IRB 7600, select the DressPack options 476-1 or 467-1 for resolver cabling to the built in 7 channel SMB.

Equipment

Manipulator cable.

Option	Description
212-2	Standard

Cable length

Option	Description
210-2	7m
210-3	15 m, not available for IRB 140
210-4	22 m, not available for IRB 140
210-5	30 m, not available for IRB 140
210-1	3 m, only available for IRB 140

2 Specification of Variants and Options

Protection for manipulator cable

not available for IRB 6600/7600.

Option	Description
288-1	Each unit length is 2 m. Totally 40 m protection can be specified.

Service outlet

Any of the following standard outlets with protective earthing can be chosen for maintenance purposes.

The maximum load permitted is 500 W (max. 100 W can be installed inside the cabinet).

Option	Description
328-6	120 V in accordance with American standard; single socket, Harvey Hubble.
328-1	230 V mains outlet in accordance with DIN VDE 0620; single socket suitable for EU countries.

Power supply

to the service outlet.

Option	Description
331-3	Connection from the main transformer. The voltage is switched on/off by the mains switch on the front of the cabinet.
331-2	Connection before mains switch which means that the voltage is always available. Note this only applies when supply voltage to the cabinet is 400 V, three-phase with neutral connection and a 230 V service socket.



Connection before mains switch is not in compliance with some national standards, NFPL 79 for example. The option 331-2 is not available for IRB 6600/7600

Memory

Removable mass memory.

Option	Memory	Description
215-1	Floppy drive	The disk drive normally works well at temperatures up to 40°C (104°F). The disk drive will not deteriorate at higher temperatures but there will be an increase in the number of reading/writing problems as the temperature increases.

Option	Memory	Description
581-2	USB Flash disk interface	An external connector located together with the standard Ethernet service port. Following USB Flash disk types are verified: SanDisk 512 Mb Iomega 128 Mb Kingston 256 Mb Pen Drive 256 Mb

Extended mass memory

Option	Description
140-1	Flash disk 128 Mb. Standard is 64 Mb

A

Absolute measurement, 24
Allen-Bradley Remote I/O, 33, 35, 56
analog signals, 33, 37
automatic operation, 24

B

backup
 computer system backup, 21
 memory, 18

C

cabinet wheels, 45
CAN/DeviceNet, 54
collision detection, 12
communication, 40
concurrent I/O, 34
configuration, 21, 33
connection, 66
 mains supply, 50
cooling device, 7
coordinate systems, 27
cross connections, 33
cursor, 13

D

diagnostics, 26
digital signals, 33
distributed I/O, 36

E

editing
 position, 23
 programs, 23
emergency stop, 12
emergency stop button, 14
enabling device, 11, 14
Encoder interface unit, 35, 56
event routine, 24
extended memory, 18
external axes, 30

F

fire safety, 12
flash disk memory, 18
fly-by point, 22
function keys, 14

H

hold-to-run control, 12
humidity, 20

I

I/O units, 35
I/O-system, 33
inputs, 33
installation, 20

Interbus Slave, 33, 35, 56
interrupt, 34

J

joystick, 14, 15

L

LAN/Ethernet, 54
language, 21
lighting
 connection, 66
 teach pendant, 48

M

mains supply, 50
mains switch, 51
mains voltage, 49
maintenance, 26
manipulator cable, 65
 length, 65
 protection, 66
mass memory, 18
memory
 backup, 18
 extended, 18
 flash disk, 18
 mass storage, 18
 RAM memory, 18
mirroring, 23
motion, 26
motion keys, 14
Multitasking, 34

N

navigation keys, 14
noise level, 7

O

operating mode, 17
operating mode selector, 16, 47
operating requirements, 20
operation, 13
operator's panel, 16
options, 43
outputs, 33
over-speed protection, 12

P

password, 23
PLC functionality, 34
position
 editing, 23
 programming, 22
position fixed I/O, 34
production window, 24
Profibus, 55
Profibus DP Slave, 33, 35, 56

- program
 - editing, 23
 - testing, 23
- programming, 22

R

- RAPID Language, 25
- reduced speed, 11

S

- safe manual movements, 12
- safeguarded space stop, 12
 - delayed, 12
- safety, 10
- safety lamp, 13
- serial communication, 40
- service, 26
- service outlets, 66
- space requirements, 7
- standards, 10
- stop point, 22
- structure, 7
- system signals, 39

T

- Teach pendant, 13
- teach pendant
 - cable, 48
 - lighting, 48
- testing programs, 23
- trap routines, 34
- troubleshooting, 26
- TrueMove, 27

V

- variants, 43
- volume, 7

W

- window keys, 14
- windows, 13
- working space
 - restricting, 12



ABB Automation Technologies AB
Robotics
S-721 68 VÄSTERÅS
SWEDEN
Telephone: +46 (0) 21 344000
Telefax: +46 (0) 21 132592

3HAC 9039-1, Revision 7, en