

# Model 266GSH Gauge Model 266ASH Absolute

## 2600T Series Pressure Transmitters Engineered solutions for all applications



### Base accuracy

- from 0.06 % of calibrated span

### Reliable sensing system coupled with very latest digital technologies

- provides large turn down ratio up to 100:1

### Comprehensive sensor choice

- optimize in-use total performance and stability

### 10-year stability

- 0.15 % of URL

### Flexible configuration facilities

- provided locally via local LCD keypad

### New TTG (Through-The-Glass) keypad technology

- allows quick and easy local configuration without opening the cover, even in explosion proof environments

### IEC 61508 certification

- for SIL2 (1oo1) and SIL3 (1oo2) applications

### Full compliance with PED Category III

# Model 266GSH Gauge

# Model 266ASH Absolute

## Functional Specifications

### Range and span limits

Sensor Code	Upper Range Limit (URL)	Lower Range Limit (LRL)	Minimum span	
			266GSH (Δ)	266ASH
C	6 kPa	-6 kPa	0.2 kPa	0.3 kPa
	60 mbar	-60 mbar	2 mbar	3 mbar
	24 inH2O	-24 inH2O	0.8 inH2O	2.25 mmHg
F	40 kPa	-40 kPa	0.4 kPa	2 kPa
	400 mbar	-400 mbar	4 mbar	20 mbar
	160 inH2O	-160 inH2O	1.6 inH2O	15 mmHg
L	250 kPa	0 abs	2.5 kPa	12.5 kPa
	2500 mbar		25 mbar	125 mbar
	1000 inH2O		10 inH2O	93.8 mmHg
D	1000 kPa	0 abs	10 kPa	50 kPa
	10 bar		0.1 bar	0.5 bar
	145 psi		1.45 psi	7.25 psi
U	3000 kPa	0 abs	30 kPa	150 kPa
	30 bar		0.3 bar	1.5 bar
	435 psi		4.35 psi	21.7 psi
R	10000 kPa	0 abs	100 kPa	
	100 bar		1 bar	
	1450 psi		14.5 psi	
V	60000 kPa	0 abs	600 kPa	
	600 bar		6 bar	
	8700 psi		87 psi	
Z	105000 kPa	0.07 kPa abs (§)	10500 kPa	
	1050 bar	0.7 mbar abs (§)	105 bar	
	15225 psi	0.5 mmHg (§)	1522 psi	

(Δ) Lower Range Limit (LRL) for 266ASH is 0 abs for all ranges.

### Span limits

Maximum span = URL

IT IS RECOMMENDED TO SELECT THE TRANSMITTER SENSOR CODE PROVIDING THE TURNDOWN VALUE AS LOWEST AS POSSIBLE TO OPTIMIZE PERFORMANCE CHARACTERISTICS.

### Zero suppression and elevation

Zero and span can be adjusted to any value within the range limits detailed in the table as long as:

– calibrated span ≥ minimum span

### Damping

Selectable time constant : between 0 and 60 s

This is in addition to sensor response time.

### Turn on time

Operation within specification in less than 10 s with minimum damping.

### Insulation resistance

> 100 MΩ at 500 V DC (terminals to earth)

## Operative limits

### Pressure limits:

#### Overpressure limits

Without damage to the transmitter

Sensors	Overpressure limits
Sensor C, F	0 absolute and 1 MPa, 10 bar, 145 psi
Sensor L	0 absolute and 0.5 MPa, 5 bar, 72.5 psi
Sensor D	0 absolute and 2 MPa, 20 bar, 290 psi
Sensor U	0 absolute and 6 MPa, 60 bar, 870 psi
Sensor R	0 absolute and 20 MPa, 200 bar, 2900 psi
Sensor V	0 absolute and 90 MPa, 900 bar, 13050 psi
Perfluoroelastomer gasket	0 absolute and 0.6 MPa abs, 6 bar abs, 87 psia @ $T \geq -15$ °C (5 °F); 0 absolute and 0.18 MPa abs, 1.8 bar abs, 26 psia @ $T \geq -25$ °C (-13 °F)

Sensors	Connection	Overpressure limits
Sensor Z	F250C	0.07 kPa abs, 0.7 mbar abs, 0.5 mmHg and 137.9 MPa, 1379 bar, 20000 psi
Sensor Z	1/4 - 18 NPT	0.07 kPa abs, 0.7 mbar abs, 0.5 mmHg and 135 MPa, 1350 bar, 19570 psi

#### Proof pressure

The transmitter can be exposed without leaking to line pressure of up to the following values:

Sensors	Overpressure limits
Sensor C, F	0 absolute and 1 MPa, 10 bar, 145 psi
Sensor L	0 absolute and 0.5 MPa, 5 bar, 72.5 psi
Sensor D	0 absolute and 2 MPa, 20 bar, 290 psi
Sensor U	0 absolute and 6 MPa, 60 bar, 870 psi
Sensor R	0 absolute and 20 MPa, 200 bar, 2900 psi
Sensor V	0 absolute and 90 MPa, 900 bar, 13050 psi
Sensor Z 1/4 NPT connection	135 MPa, 1350 bar, 19570 psi
Sensor Z F250C connection	210 MPa, 2100 bar, 30000 psi
Perfluoroelastomer gasket	0 absolute and 0.6 MPa abs, 6 bar abs, 87 psia @ $T \geq -15$ °C (5 °F); 0 absolute and 0.18 MPa abs, 1.8 bar abs, 26 psia @ $T \geq -25$ °C (-13 °F)

Meet ANSI/ISA-S 82.03 hydrostatic test requirements.

## Temperature limits °C ( °F ) :

### Ambient

is the operating temperature

Models 266GSH - 266ASH	Ambient temperature limits
Silicone oil	-40 and 85 °C (-40 and 185 °F)
Inert (Galden)	-40 and 85 °C (-40 and 185 °F)
White oil	-6 and 85 °C (21 and 185 °F)
Sensor Z without filling	-40 and 85 °C (-40 and 185 °F)

For Hazardous Atmosphere applications see the temperature range specified on the certificate/approval relevant to the aimed type of protection

Models 266GSH - 266ASH	Ambient temperature limits
LCD integral display	-40 and 85 °C (-40 and 185 °F)
Viton gasket	-20 and 85 °C (-4 and 185 °F)
Perfluoroelastomer gasket (see also section Pressure limits)	-25 resp. -15 and 80 °C (-13 resp. 5 and 176 °F)

LCD display may not be clearly readable below -20 °C (-4 °F) or above +70 °C (+158 °F)

### Process

Models 266GSH - 266ASH	Process temperature limits
Silicone oil	-50 and 121 °C (-58 and 250 °F)
Inert (Galden)	-40 and 121 °C (-40 and 250 °F)
White oil	-6 and 121 °C (21 and 250 °F)
Sensor Z without filling	-40 and 121 °C (-40 and 250 °F)
Viton gasket	-20 and 121 °C (-4 and 250 °F)
Perfluoroelastomer gasket (see also section Pressure limits)	-25 resp. -15 and 80 °C (-13 resp. 5 and 176 °F)

### Storage

Models 266GSH - 266ASH	Storage temperature limits
Storage limits	-50 and 85 °C (-58 and 185 °F)
White oil	-6 and 85 °C (21 and 185 °F)
LCD integral display	-40 and 85 °C (-40 and 185 °F)

# Model 266GSH Gauge

# Model 266ASH Absolute

## Environmental limits

### Electromagnetic compatibility (EMC)

Comply with EN 61326 and NAMUR NE-21  
Surge immunity level (with surge protector): 4 kV  
(according to IEC 1000-4-5 EN 61000-4-5)

### Pressure equipment directive (PED)

Comply with 97/23/EEC Category III Module H.

### Humidity

Relative humidity: up to 100 %  
Condensing, icing: admissible

### Vibration resistance

Accelerations up to 2 g at frequency up to 1000 Hz  
(according to IEC 60068-2-6)

### Shock resistance

Acceleration: 50 g  
Duration: 11 ms  
(according to IEC 60068-2-27)

### Wet and dust-laden atmospheres

The transmitter is dust and sand tight and protected against immersion effects as defined by EN 60529 (1989) to IP 67 (IP 68 on request) or by NEMA to 4X or by JIS to C0920. IP65 with Harting Han connector.

## Hazardous atmospheres

With or without integral display

---

### INTRINSIC SAFETY:

ATEX Europe (code E1) and IEC Ex (code E8) approval

II 1 G Ex ia IIC T6/T5/T4 and

II 1/2 G Ex ia IIC T6/T5/T4; IP67.

II 1 D Ex iaD 20 T85 °C and

II 1/2 D Ex iaD 21 T85 °C; IP67.

NEPSI China (code EY)

Ex ia IIC T4~T6, DIP A20TA, T4~T6.

---

### EXPLOSION PROOF:

ATEX Europe (code E2) and IEC Ex (code E9) approval

II 1/2 G Ex d IIC T6 and

II 1/2 D Ex tD A21 T85 °C (–50 °C ≤ Ta ≤ +75 °C); IP67.

NEPSI China (code EZ)

Ex d IIC T6, DIP A21TA, T6.

---

### TYPE "N":

ATEX Europe (code E3 ) and IEC Ex (code ER) type examination

II 3 G Ex nL IIC T6/T5/T4 and

II 3 D Ex tD A22 T85 °C; IP67.

NEPSI China (code ES) type examination

Ex nL IIC T4~T6, DIP A22TA, T6.

---

FM Approvals US (code E6) and

FM Approvals Canada (code E4):

– Explosionproof (US): Class I, Div. 1, Groups A, B, C, D

– Explosionproof (Canada): Class I, Div. 1, Groups B, C, D

– Dust ignitionproof : Class II, Div. 1, Groups E, F, G

– Suitable for: Class II, Div. 2, Groups F, G; Class III, Div.1, 2

– Nonincendive: Class I, Div. 2, Groups A, B, C, D

– Intrinsically safe: Class I, II, III, Div. 1, Groups A, B, C, D, E, F, G

Class I, Zone 0 AEx ia IIC T6/T4, Zone 0 (FM US)

Class I, Zone 0 Ex ia IIC T6/T4, Zone 0 (FM Canada)

---

COMBINED ATEX (code EW = E1 + E2 + E3), (code E7 = E1 + E2)

---

COMBINED ATEX and FM Approvals (code EN = EW + E4 + E6)

---

COMBINED FM Approvals US and Canada

– Intrinsically safe (code EA)

– Explosionproof (code EB)

– Nonincendive (code EC)

---

COMBINED IEC (code EH = E8 + E9), (code EI = E8 + E9 + ER)

---

COMBINED NEPSI (code EP = EY + EZ), (code EQ = EY + EZ + ES)

– GOST (Russia), GOST (Kazakhstan), GOST (Belarus), Inmetro (Brazil)

---

based on ATEX

REFER TO CERTIFICATES FOR AMBIENT TEMPERATURE RANGES (WITHIN THE LIMITS OF -50 TO 85°C) RELATED TO THE DIFFERENT TEMPERATURE CLASSES

## Electrical Characteristics and Options

### HART digital communication and 4 to 20mA output Power Supply

The transmitter operates from 10.5 to 42 V DC with no load and is protected against reverse polarity connection (additional load allows operations over 42 V DC).

For Ex ia and other intrinsically safe approval power supply must not exceed 30 V DC.

Minimum operating voltage increase to 12.3 V DC with optional surge protector

### Ripple

20 mV max on a 250  $\Omega$  load as per HART specifications.

### Load limitations

4 to 20 mA and HART total loop resistance :

$$R \text{ (k}\Omega\text{)} = \frac{\text{Supply voltage} - \text{min. operating voltage (V DC)}}{22 \text{ mA}}$$

A minimum of 250  $\Omega$  is required for HART communication.

### Optional indicators

#### Integral display (code L1)

Wide screen LCD, 128 x 64 pixel,

52.5 x 27.2 mm (2.06 x 1.07 in.) dot matrix. Multilanguage.

Four keys for configuration and management of device.

Easy setup for quick commissioning.

User selectable application-specific visualizations.

Totalized and instantaneous flow indication.

Display may also indicate static pressure, sensor temperature and diagnostic messages and provides configuration facilities.

#### Through-the-glass (TTG) controlled display (code L5)

As above integral display but equipped with the innovative TTG keypad allowing the activation of the configuration and management menus of the device without the need of removing the transmitter housing cover.

TTG keypad is protected against accidental activations.



### Optional surge protection

Up to 4kV

– voltage 1.2  $\mu$ s rise time / 50  $\mu$ s delay time to half value

– current 8  $\mu$ s rise time / 20  $\mu$ s delay time to half value

### Output signal

Two-wire 4 to 20 mA, user-selectable for linear or 22 points linearization table (i.e. for horizontal or spherical tank level measurement).

HART® communication provides digital process variable superimposed on 4 to 20 mA signal, with protocol based on Bell 202 FSK standard.

### Output current limits (to NAMUR standard)

Overload condition

- Lower limit: 3.8 mA (configurable from 3.8 to 4 mA)

- Upper limit: 20.5 mA (configurable from 20 to 21 mA)

### Alarm current

- Lower limit: 3.6 mA (configurable from 3.6 to 4 mA)

- Upper limit: 21 mA (configurable from 20 to 22 mA)

Factory setting: high alarm current

### Process diagnostics (PILD)

Plugged impulse line detection (PILD) generates a warning via HART communication. The device can also be configured to drive the analog output signal to the "Alarm current".

# Model 266GSH Gauge

## Model 266ASH Absolute

### FOUNDATION Fieldbus output

#### Device type

LINK MASTER DEVICE

Link Active Scheduler (LAS) capability implemented.

Manufacturer code: 000320 (hex)

Device type code: 0007 (hex)

#### Power supply

The transmitter operates from 9 to 32 V DC, polarity independent, with or without surge protector.

For Ex ia approval power supply must not exceed 24 V DC (entity certification) or 17.5 V DC (FISCO certification), according to FF-816.

#### Current consumption

operating (quiescent): 15 mA

fault current limiting: 20 mA max.

#### Output signal

Physical layer in compliance to IEC 1158-2/EN 61158-2 with transmission to Manchester II modulation, at 31.25 kbit/s.

#### Function blocks/execution period

3 enhanced Analog Input blocks/25 ms max (each)

1 enhanced PID block/40 ms max.

1 standard ARithmetic block/25 ms

1 standard Input Selector block/25 ms

1 standard Control Selector block/25 ms

1 standard Signal Characterization block/25 ms

1 standard Integrator/Totalizer block/25 ms

#### Additional blocks

1 enhanced Resource block,

1 custom Pressure with calibration transducer block

1 custom Advanced Diagnostics transducer block including

Plugged Input Line Detection

1 custom Local Display transducer block

#### Number of link objects

35

#### Number of VCRs

35

### Output interface

FOUNDATION fieldbus digital communication protocol to standard H1, compliant to specification V. 1.7.

#### Integral display

Wide screen LCD, 128 x 64 pixel,

52.5 x 27.2 mm (2.06 x 1.07 in.) dot matrix. Multilanguage.

Four keys for configuration and management of device.

Easy setup for quick commissioning.

User selectable application-specific visualizations.

Totalized and instantaneous flow indication.

Display may also indicate static pressure, sensor temperature and diagnostic messages and provides configuration facilities.

#### Transmitter failure mode

The output signal is “frozen” to the last valid value on gross transmitter failure condition, detected by self-diagnostics which also indicate a BAD conditions. If electronic failure or short circuit occur the transmitter consumption is electronically limited at a defined value (20 mA approx), for safety of the network.

## PROFIBUS PA output

### Device type

Pressure transmitter compliant to Profiles 3.0.1  
Identification number: 3450 (hex)

### Power supply

The transmitter operates from 9 to 32 V DC, polarity independent, with or without surge protector.  
For Ex ia approval power supply must not exceed 17.5 V DC.  
Intrinsic safety installation according to FISCO model.

### Current consumption

operating (quiescent): 15 mA  
fault current limiting: 20 mA max.

### Output signal

Physical layer in compliance to IEC 1158-2/EN 61158-2 with transmission to Manchester II modulation, at 31.25 kbit/s.

### Output interface

PROFIBUS PA communication according to Profibus DP50170 Part 2/DIN 19245 part 1-3.

### Output update time

25 ms

### Data blocks

3 analog input, 1 physical.

### Additional blocks

1 Pressure with calibration transducer block  
1 Advanced Diagnostics transducer block including Plugged Input Line Detection  
1 Local Display transducer block

### Integral display

Wide screen LCD, 128 x 64 pixel,  
52.5 x 27.2 mm (2.06 x 1.07 in.) dot matrix. Multilanguage.  
Four keys for configuration and management of device.  
Easy setup for quick commissioning.  
User selectable application-specific visualizations.  
Instantaneous flow indication.

Display may also indicate static pressure, sensor temperature and diagnostic messages and provides configuration facilities.

### Transmitter failure mode

On gross transmitter failure condition, detected by self-diagnostics, the output signal can be driven to defined conditions, selectable by the user as safe, last valid or calculated value.

If electronic failure or short circuit occur the transmitter consumption is electronically limited at a defined value (20 mA approx), for safety of the network.

## Performance specifications

Stated at reference condition to IEC 60770 ambient temperature of 20 °C (68 °F), relative humidity of 65 %, atmospheric pressure of 1013 hPa (1013 mbar), zero based range for transmitter with isolating diaphragms in ceramic, AISI 316 L ss or Hastelloy and silicone oil fill and HART digital trim values equal to 4 mA and to 20 mA span end points, in linear mode.

Unless otherwise specified, errors are quoted as % of span. Some performance referring to the Upper Range Limit are affected by the actual turndown (TD) as ratio between Upper Range Limit (URL) and calibrated span.

IT IS RECOMMENDED TO SELECT THE TRANSMITTER SENSOR CODE PROVIDING THE TURNDOWN VALUE AS LOWEST AS POSSIBLE TO OPTIMIZE PERFORMANCE CHARACTERISTICS.

### Dynamic performance (according to IEC 61298-1 definition)

Sensors	Time constant (63.2 % of total step change)
Sensor C to V	150 ms
Sensor Z	200 ms
Dead time for all sensors	40 ms

Response time (total) = dead time + time constant

### Accuracy rating

% of calibrated span, including combined effects of terminal based linearity, hysteresis and repeatability.

For fieldbus versions SPAN refer to analog input function block outscale range

Model	Sensor	for TD up to	
266GSH	L, D, U, R	from 1:1 to 10:1	± 0.06 %
	L, D, U, R	from 10:1 to 100:1	± (0.006 x TD) %
	F, V	from 1:1 to 10:1	± 0.075 %
	F, V	from 10:1 to 100:1	± (0.0075 x TD) %
	C	from 1:1 to 10:1	± 0.075 %
	C	from 10:1 to 30:1	± (0.0075 x TD) %
	Z	from 1:1 to 5:1	± 0.15 %
	Z	from 5:1 to 10:1	± (0.03 x TD) %
266GSH	F to R	from 1:1 to 5:1	± 0.04 %
(option D2)	L, D, U, R	from 5:1 to 100:1	± (0.0105 + 0.0059 x TD) %
(option D2)	F	from 5:1 to 100:1	± (0.003 + 0.0074 x TD) %
266ASH	C to U	from 1:1 to 10:1	± 0.075 %
	C to U	from 10:1 to 20:1	± (0.0075 x TD) %

# Model 266GSH Gauge

# Model 266ASH Absolute

## Ambient temperature

per 20K change between the limits of -40 °C to +85 °C  
(per 36 °F change between the limits of -40 to +185 °F):

Model	Sensor	for TD up to	
266GSH	C and F	10:1	± (0.06 % URL + 0.09 % span)
	L to R	10:1	± (0.03 % URL + 0.045 % span)
	V	10:1	± (0.04 % URL + 0.065 % span)
	Z	10:1	± (0.06 % URL + 0.10 % span)
266ASH	C and F	10:1	± (0.06 % URL + 0.09 % span)
	L to U	10:1	± (0.03 % URL + 0.045 % span)

for an ambient temperature change from -10 °C to +60 °C  
(+14 to +140 °F):

Model	Sensor	for TD up to	
266GSH	C and F	10:1	± (0.08 % URL + 0.08 % span)
	L to R	10:1	± (0.06 % URL + 0.06 % span)
	V	10:1	± (0.075 % URL + 0.11 % span)
	Z	10:1	± (0.10 % URL + 0.15 % span)
266ASH	C and F	10:1	± (0.2 % URL + 0.1 % span)
	L to U	10:1	± (0.06 % URL + 0.06 % span)

per 10K change between the limits of -40 °C to -10 °C or  
+60° to +85 °C (per 18 °F change between the limits of -40  
to +14 °F or +140° to +185 °F):

Model	Sensor	for TD up to	
266GSH	C and F	10:1	± (0.04 % URL + 0.05 % span)
	L to R	10:1	± (0.03 % URL + 0.045 % span)
	V	10:1	± (0.04 % URL + 0.055 % span)
	Z	10:1	± (0.06 % URL + 0.10 % span)
266ASH	C and F	10:1	± (0.1 % URL + 0.05 % span)
	L to U	10:1	± (0.03 % URL + 0.045 % span)

## Supply voltage

Within voltage/load specified limits the total effect is less than  
0.005 % of URL per volt.

## Load

Within load/voltage specified limits the total effect is negligible.

## Electromagnetic field

Meets all the requirements of EN 61326 and NAMUR NE-21.

## Common mode interference

No effect from 100Vrms @ 50Hz, or 50 V DC

## Mounting position

Standard recommended installation position is vertical with  
process connection at the bottom.

A tilt from vertical causes a zero shift which can be corrected  
with zero adjustment. For sensor C and F an additional  
temperature effect on zero up to 0.02 mbar/10K should be  
considered with a tilt up to 90° from vertical.

## Stability

±0.15 % of URL over a ten years period for sensors C to V  
±0.45 % of URL over a ten years period for sensor Z

## Total performance

similar to DIN 16086

Temperature change in the range from -10 to 60 °C (14 to 140 °F)

Model	Sensor	for TD up to	
266GSH	L to V	1:1	± 0.14 % of calibrated span
266ASH	L to R	1:1	± 0.14 % of calibrated span

Total performance includes the measurement deviation of  
- non-linearity including hysteresis and non-reproducibility,  
- thermal change of ambient temperature on zero and span

$$E_{\text{perf}} = \sqrt{(E_{\Delta Tz} + E_{\Delta Ts})^2 + E_{\text{lin}}^2}$$

$E_{\text{perf}}$  = Total Performance

$E_{\Delta Tz}$  = Effect of the ambient temperature on zero

$E_{\Delta Ts}$  = Effect of the ambient temperature on span

$E_{\text{lin}}$  = Accuracy rating (for terminal-based linearity 0.06 % or  
0.075% as per sensor accuracy)



## Physical Specification

(Refer to ordering information sheets for variant availability related to specific model or versions code)

### Materials

#### Process isolating diaphragms (\*)

Ceramic (Al<sub>2</sub>O<sub>3</sub>) (sensor C and F);

Hastelloy C276™ (sensor C to V);

Hastelloy C276™ gold-plated (sensor L to V);

Inconel 718 (for sensor Z).

#### Process connection (\*)

AISI 316 L ss; Hastelloy C-276™ (sensor C to V).

Inconel 718 (sensor Z)

#### Gasket (only for sensor codes C, F) (\*)

Viton™, Perfluoroelastomer, Perbunan (NBR).

#### Sensor fill fluid

Silicone oil; Inert fill (Galden™);

white oil (FDA).

#### Mounting bracket (\*\*)

Zinc plated carbon steel with chrome passivation; AISI 316 L ss.

#### Sensor housing

AISI 316 L ss.

### Electronic housing and covers

Aluminium alloy (copper content  $\leq 0.3$  %) with baked epoxy finish (colour RAL9002);

AISI 316 L ss.

#### Covers O-ring

Buna N.

#### Local adjustments (zero, span and write protect)

Glass filled polyphenylene oxide (removable).

#### Plates

AISI 316ss for transmitter nameplate, certification plate, optional tag/calibration plate attached to the electronics housing and optional wired-on customer data plate. All printing by laser.

#### Calibration

Standard: at maximum span, zero based range, ambient temperature and pressure;

Optional: at specified range and ambient conditions.

(\*) Wetted parts of the transmitter.

(\*\*) U-bolt material: high-strength alloy steel or AISI 316 L ss;  
bolts/nuts material: high-strength alloy steel or AISI 316 ss.

# Model 266GSH Gauge

## Model 266ASH Absolute

### Optional extras

#### Mounting brackets

For 60mm. (2in) pipes or wall mounting.

#### Display

4-position (at 90°) user orientable.

#### Optional plates

Code I2: for tag (up to 31 characters) and calibration details (up to 31 characters: lower and upper values plus unit) fixed onto transmitter housing.

Code I1: for customer data (32 character x 4 lines) wired-on transmitter housing

#### Surge protection

#### Cleaning procedure for oxygen service

#### Test Certificates (test, design, calibration, material traceability)

#### Tag and manual language

#### Communication connectors

### Process connections

#### For sensors C to V

$\frac{1}{2}$  – 14 NPT male or female; DIN EN837-1 G  $\frac{1}{2}$  B.

#### For sensor Z

$\frac{1}{4}$  – 18 NPT female; F250C (autoclave).

### Electrical connections

Two  $\frac{1}{2}$  – 14 NPT or M20x1.5 threaded conduit entries, direct on housing.

Special communication connector (on request)

– HART : straight or angle Harting Han 8D connector and one plug.

– FOUNDATION Fieldbus, PROFIBUS PA: M12x1 or 7/8 in.

#### Terminal block

HART version: three terminals for signal/external meter wiring up to 2.5 mm<sup>2</sup> (14 AWG), also connection points for test and communication purposes.

Fieldbus versions: two terminals for signal wiring (bus connection) up to 2.5 mm<sup>2</sup> (14 AWG)

#### Grounding

Internal and external 6 mm<sup>2</sup> (10 AWG) ground termination points are provided.

### Mounting position

Transmitter can be mounted in any position.

Electronics housing may be rotated to any position. A positive stop prevents over travel.

### Mass (without options)

2 kg approx (4.4 lb); add 1.5 kg (3.3 lb) for AISI housing.

Add 650 g (1.5 lb) for packing.

### Packing

Carton 27 x 24 x 20 cm approx (11 x 10 x 8 in.).

## Configuration

### Transmitter with HART communication and 4 to 20 mA Standard configuration

Transmitters are factory calibrated to customer's specified range. Calibrated range and tag number are stamped on the tag plate. If a calibration range and tag data are not specified, the transmitter will be supplied with the plate left blank and configured as follows:

Engineering Unit	kPa
4 mA	Zero
20 mA	Upper Range Limit (URL)
Output	Linear
Damping	1 s
Transmitter failure mode	Upscale
Software tag (8 characters max)	Blank
Optional LCD display	PV in kPa; output in mA and in percentage on bargraph

Any or all the above configurable parameters, including Lower range-value and Upper range-value which must be the same unit of measure, can be easily changed using the HART hand-held communicator or by a PC running the configuration software with DTM for 266 models. The transmitter database is customized with specified flange type and material, O-ring and drain/vent materials and meter code option.

#### Custom configuration (option N6)

The following data may be specified in addition to the standard configuration parameters:

Descriptor	16 alphanumeric characters
Message	32 alphanumeric characters
Date	Day, month, year

For HART protocol available engineering units of pressure measure are :

Pa, kPa, MPa

inH<sub>2</sub>O@4 °C, mmH<sub>2</sub>O@4 °C, psi

inH<sub>2</sub>O@20 °C, ftH<sub>2</sub>O@20 °C, mmH<sub>2</sub>O@20 °C

inHg, mmHg, Torr

g/cm<sup>2</sup>, kg/cm<sup>2</sup>, atm

mbar, bar

These and others are available for PROFIBUS and FOUNDATION Fieldbus.

### Transmitter with PROFIBUS PA communication Standard configuration

Transmitters are factory calibrated to customer's specified range. Calibrated range and tag number are stamped on the tag plate. If a calibration range and tag data are not specified, the transmitter will be supplied with the plate left blank and configured as follows:

Measure Profile	Pressure
Engineering Unit	kPa
Output scale 0 %	Lower Range Limit (LRL)
Output scale 100 %	Upper Range Limit (URL)
Output	Linear
Hi-Hi Limit	Upper Range Limit (URL)
Hi Limit	Upper Range Limit (URL)
Low Limit	Lower Range Limit (LRL)
Low-Low Limit	Lower Range Limit (LRL)
Limits hysteresis	0.5 % of output scale
PV filter	0 s
Address (set by local key)	126
Tag	32 alphanumeric characters
Optional LCD display	PV in kPa; output in percentage on bargraph

Any or all the above configurable parameters, including the range values which must be the same unit of measure, can be easily changed by a PC running the configuration software with DTM for 266 models. The transmitter database is customized with specified flange type and material, O-ring and drain/vent materials and meter code option.

#### Custom configuration (option N6)

The following data may be specified in addition to the standard configuration parameters:

Descriptor	32 alphanumeric characters
Message	32 alphanumeric characters
Date	Day, month, year

# Model 266GSH Gauge

## Model 266ASH Absolute

### Transmitter with FOUNDATION Fieldbus communication

#### Standard configuration

Transmitters are factory calibrated to customer's specified range. Calibrated range and tag number are stamped on the tag plate. If a calibration range and tag data are not specified, the transmitter will be supplied with the plate left blank and the analog input function block FB1 is configured as follows:

Measure Profile	Pressure
Engineering Unit	kPa
Output scale 0 %	Lower Range Limit (LRL)
Output scale 100 %	Upper Range Limit (URL)
Output	Linear
Hi-Hi Limit	Upper Range Limit (URL)
Hi Limit :	Upper Range Limit (URL)
Low Limit	Lower Range Limit (LRL)
Low-Low Limit	Lower Range Limit (LRL)
Limits hysteresis	0.5 % of output scale
PV filter time	0 s
Tag	32 alphanumeric characters
Optional LCD display	PV in kPa; output in percentage on bargraph

The analog input function block FB2 and FB3 are configured respectively for the sensor temperature measured in °C and for the static pressure measured in MPa.

Any or all the above configurable parameters, including the range values, can be changed using any host compliant to FOUNDATION fieldbus. The transmitter database is customized with specified flange type and material, O-ring and drain/vent materials and meter code option.

#### Custom configuration (option N6)

The following data may be specified in addition to the standard configuration parameters:

Descriptor	32 alphanumeric characters
Message	32 alphanumeric characters
Date	Day, month, year

## MOUNTING DIMENSIONS (not for construction unless certified) – dimensions in mm (in.)

### Transmitter with barrel housing - 1/2 NPT female connection

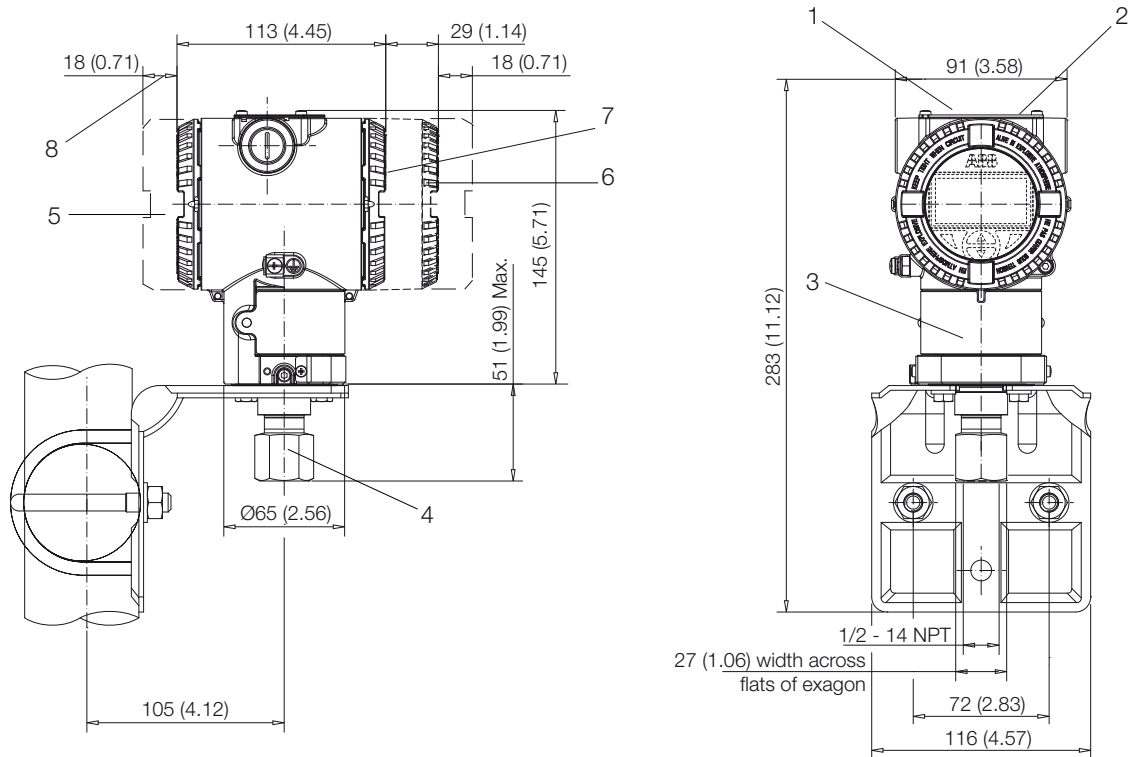

1 Adjustments | 2 Identification plate | 3 Certification plate | 4 Process connection | 5 Terminal side | 6 Integral display housing | 7 Electronic side | 8 Space for cover removal

### Transmitter with DIN aluminium housing - 1/2 NPT male connection

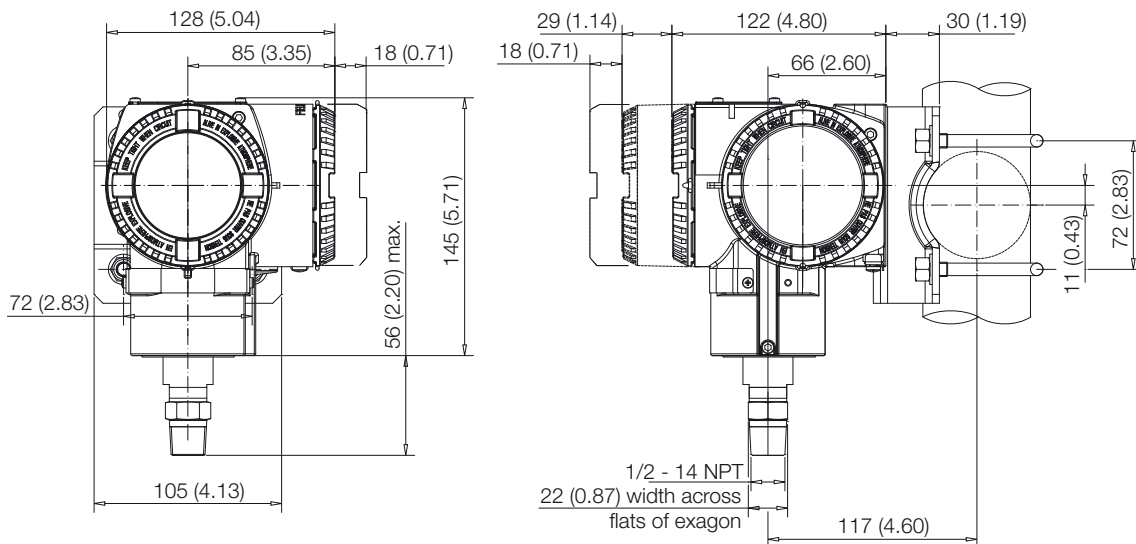

# Model 266GSH Gauge Model 266ASH Absolute

## Transmitter with barrel housing - DIN-EN837-1 G 1/2 B connection

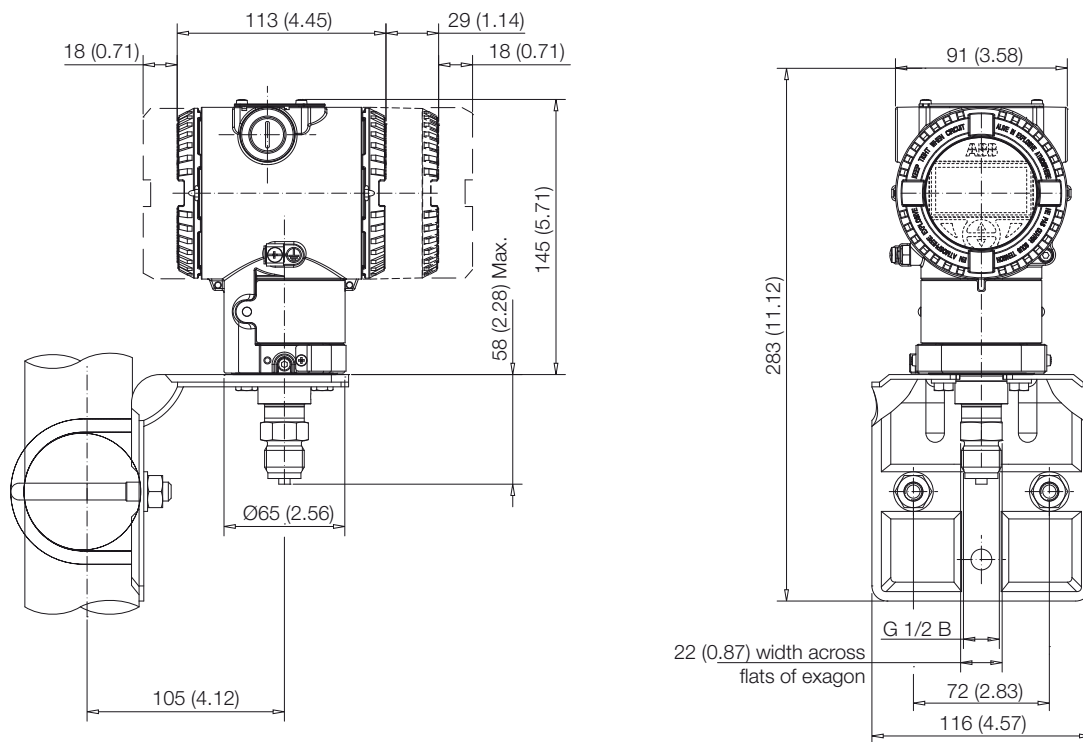

**Transmitter with barrel housing - F250C female connection for sensor Z**

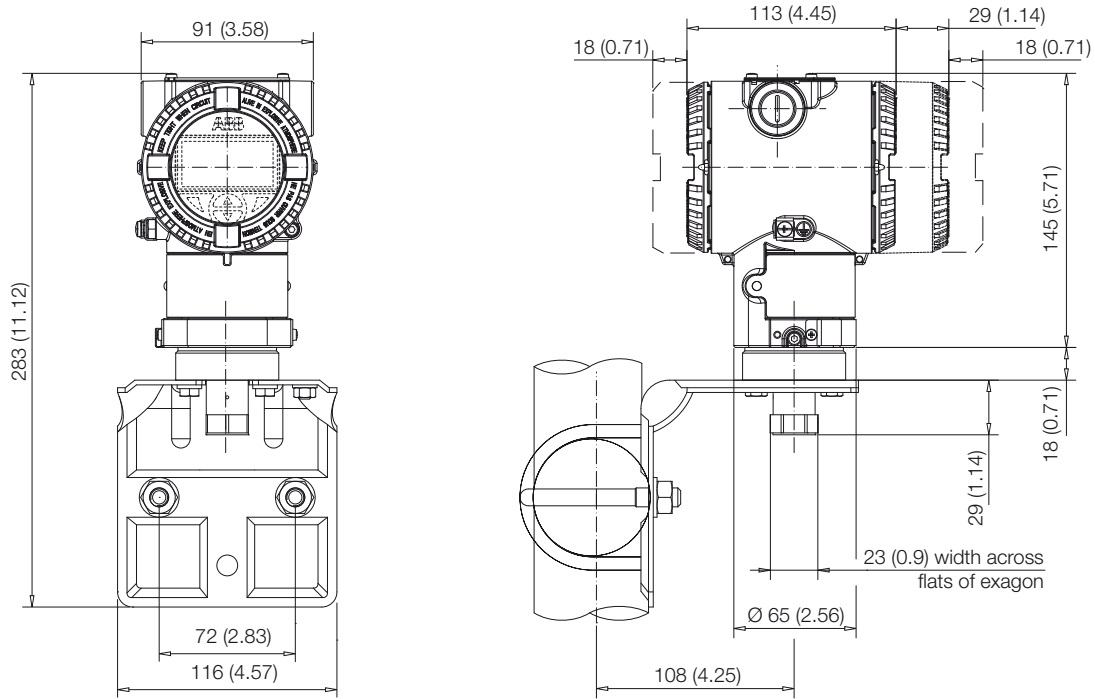

**Transmitter with barrel housing - 1/4 NPT female connection for sensor Z**

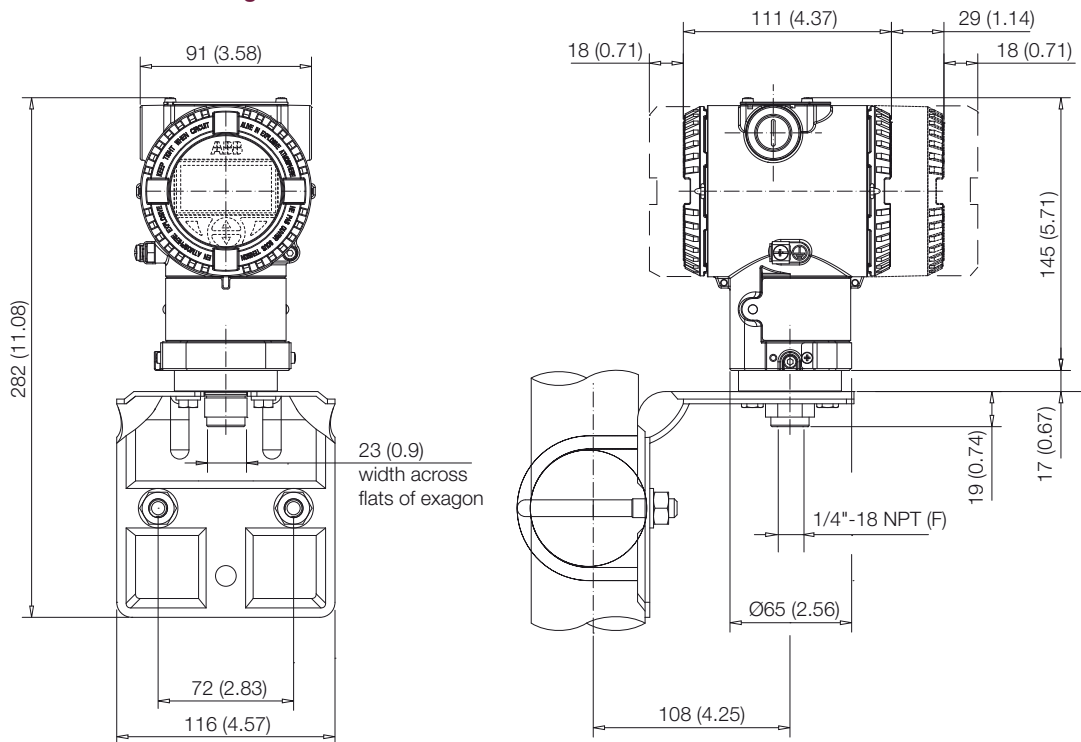

# Model 266GSH Gauge Model 266ASH Absolute

## Electrical connections

### HART Version

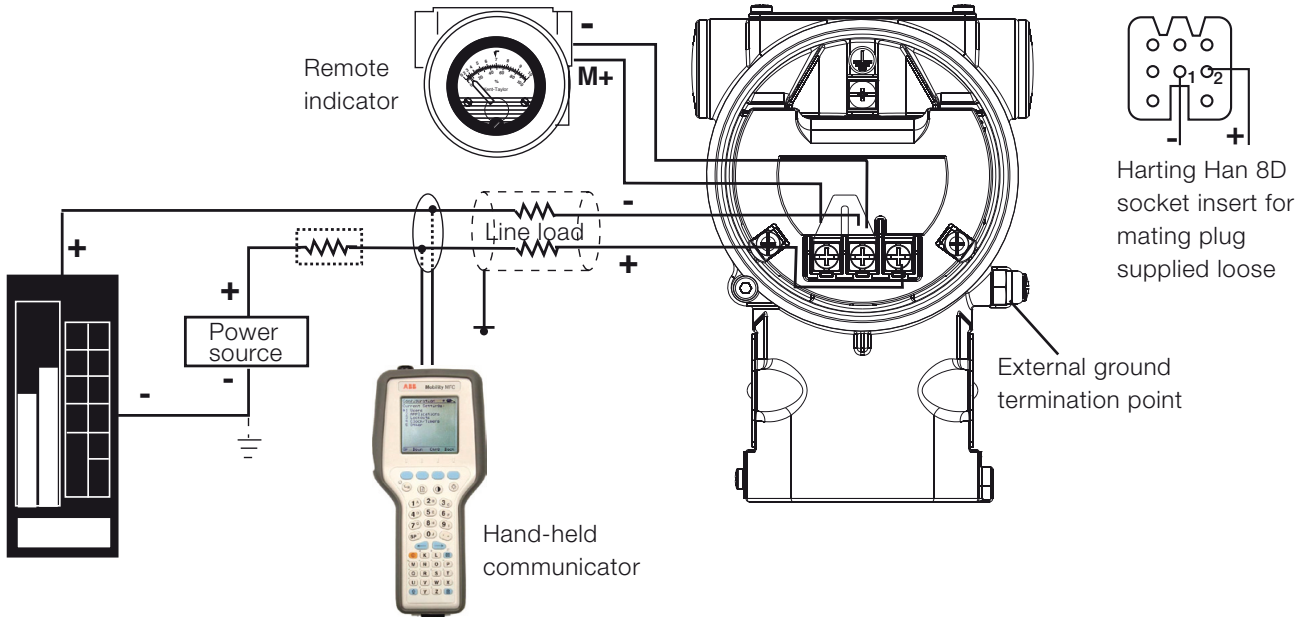

HART hand-held communicator may be connected at any wiring termination point in the loop, providing the minimum resistance is 250 ohm. If this is less than 250 ohm, additional resistance should be added to allow communications.

### FIELDBUS Versions

7/8 in connector

M12 x 1 connector

Internal ground termination point

Fieldbus line (polarity independent)

External ground termination point

PIN (male) IDENTIFICATION		
	FOUNDATION	PROFIBUS
	Fieldbus	PA
1	DATA -	DATA +
2	DATA +	GROUND
3	SHIELD	DATA -
4	GROUND	SHIELD

CONNECTOR IS SUPPLIED LOOSE WITHOUT MATING FEMALE PLUG



**BASIC ORDERING INFORMATION model 266GSH Gauge Pressure Transmitter**

Select one character or set of characters from each category and specify complete catalog number.

Refer to additional ordering information and specify one or more codes for each transmitter if additional options are required.

<b>BASE MODEL</b> - 1 <sup>st</sup> to 6 <sup>th</sup> characters			<b>2 6 6 G S H</b>	<b>X</b>	<b>X</b>	<b>X</b>	<b>X</b>	<b>X</b>	<b>X</b>
Gauge Pressure Transmitter – BASE ACCURACY 0.06 %									
<b>SENSOR - Span limits</b> - 7 <sup>th</sup> character									
0.2 and 6 kPa	2 and 60 mbar	0.8 and 24 inH2O		C					
0.4 and 40 kPa	4 and 400 mbar	1.6 and 160 inH2O		F					
2.5 and 250 kPa	25 and 2500 mbar	10 and 1000 inH2O		L					
10 and 1000 kPa	0.1 and 10 bar	1.45 and 145 psi		D					
30 and 3000 kPa	0.3 and 30 bar	4.35 and 435 psi		U					
100 and 10000 kPa	1 and 100 bar	14.5 and 1450 psi		R					
600 and 60000 kPa	6 and 600 bar	87 and 8700 psi		V					
10500 and 105000 kPa	105 and 1050 bar	1522 and 15225 psi		Z					
<b>Diaphragm material / Fill fluid (wetted parts)</b> - 8 <sup>th</sup> character									
Hastelloy C276™	Silicone oil	(Notes 2, 11)	NACE	K					
Hastelloy C276™gold-plated	Silicone oil	(Notes 2, 11)	NACE	G					
Hastelloy C276™	Inert fluid - Galden	(Notes 1, 2, 11)	NACE	F					
Hastelloy C276™gold-plated	Inert fluid - Galden	(Notes 1, 2, 11)	NACE	E					
Hastelloy C276™	White oil (FDA)	(Notes 2, 11)	NACE	Z					
Ceramic	No filling	(Notes 4, 11)	NACE	J					
Inconel 718	No filling	(for sensor Z ONLY) (Notes 12)	NACE	N					

continued  
see next page

# Model 266GSH Gauge Model 266ASH Absolute

BASIC ORDERING INFORMATION model 266GSH Gauge Pressure Transmitter					2	6	G	S	H	X	X	X	X
<b>Process connection (wetted parts) - 9<sup>th</sup> character</b>													
AISI 316 L ss	1/2 – 14 NPT-f female	(Note 11)	NACE	B									
AISI 316 L ss	1/2 – 14 NPT-f male	(Note 11)	NACE	T									
AISI 316 L ss	DIN EN837-1 G 1/2 B	(Note 11)	NACE	P									
Hastelloy C-276™	1/2 – 14 NPT-f female	(Note 11)	NACE	E									
Hastelloy C-276™	1/2 – 14 NPT-f male	(Note 11)	NACE	K									
Hastelloy C-276™	DIN EN837-1 G 1/2 B	(Note 11)	NACE	D									
Inconel 718	F250C	(for sensor Z ONLY)	(Note 12)	NACE	6								
Inconel 718	1/4 – 18 NPT-f female	(for sensor Z ONLY)	(Note 12)	NACE	7								
<b>Gasket - 10<sup>th</sup> characters</b>													
Viton™		(Notes 1, 4, 11)									5		
Perfluoroelastomer (MWP = 0.6 MPa)		(Notes 4, 11)									6		
Perbunan		(Notes 4, 11)									8		
None		(Note 2)									N		
<b>Housing material and electrical connection - 11<sup>th</sup> character</b>													
Aluminium alloy ( barrel version)	1/2 – 14 NPT												A
Aluminium alloy ( barrel version)	M20 x 1.5 (CM 20)												B
Aluminium alloy ( barrel version)	Harting Han 8D connector	(general purpose only)	(Note 5)										E
Aluminium alloy ( barrel version)	Fieldbus connector	(general purpose only)	(Note 5)										G
AISI 316 L ss ( barrel version)	1/2 – 14 NPT												S
AISI 316 L ss ( barrel version)	M20 x 1.5 (CM20)												T
AISI 316 L ss ( barrel version)	Fieldbus connector	(general purpose only)	(Note 5)										Z
Aluminium alloy (DIN version)	M20 x 1.5 (CM20)	(not Ex d or XP)											J
Aluminium alloy (DIN version)	Harting Han 8D connector	(general purpose only)	(Note 5)										K
Aluminium alloy (DIN version)	Fieldbus connector	(general purpose only)	(Note 5)										W
<b>Output/Additional options - 12<sup>th</sup> character</b>													
HART digital communication and 4 to 20 mA	No additional options										(Notes 6, 7)		H
HART digital communication and 4 to 20 mA	Options requested by “Additional ordering code”										(Note 6)		1
PROFIBUS PA	No additional options										(Notes 6, 7)		P
PROFIBUS PA	Options requested by “Additional ordering code”										(Note 7)		2
FOUNDATION Fieldbus	No additional options										(Notes 6, 7)		F
FOUNDATION Fieldbus	Options requested by “Additional ordering code”										(Note 7)		3
HART and 4 to 20 mA Safety - certified to IEC 61508	No additional options										(Notes 6, 7, 11)		T
HART and 4 to 20 mA Safety - certified to IEC 61508	Options requested by “Additional ordering code”										(Note 6, 11)		8

## ADDITIONAL ORDERING INFORMATION for model 266GSH

Add one or more 2-digit code(s) after the basic ordering information to select all required options

	XX	XX	XX	XX	XX
<b>Accuracy</b>					
0.04 % accuracy for applicable ranges (Notes 13)	D2				
<b>Hazardous area certifications</b>					
ATEX Intrinsic Safety II 1 G and II 1/2 G Ex ia IIC T6; II 1 D Ex iaD 20 T 95 °C and II 1/2D Ex iaD 21 T95 °C (Notes 6, 7)					E1
ATEX Explosion Proof Group II Category 1/2 G Ex d IIC T6 and Group II Cat. 1/2 D Ex tD A21 IP67 T85 °C (Notes 2, 6, 7, 8)					E2
ATEX Type „N“ Group II Category 3 G Ex nL IIC T6 and Group II Category 3 D Ex tD A22 IP67 T85 °C (Notes 6, 7)					E3
Combined ATEX - Intrinsic Safety, Explosion Proof and Type „N“ (Notes 6, 7, 8, 9)					EW
Combined ATEX - Intrinsic Safety and Explosion Proof (Notes 6, 7, 8, 9)					E7
Combined ATEX, FM Approvals (USA) and FM Approvals (Canada) (Notes 6, 7, 8, 9)					EN
FM Approvals (Canada) approval (Notes 6, 7, 8, 9)					E4
FM Approvals (USA) approval (Notes 6, 7, 8, 9)					E6
FM Approvals (USA and Canada) Intrinsic Safety (Notes 6, 7)					EA
FM Approvals (USA and Canada) Explosion Proof (Notes 2, 6, 7, 8)					EB
FM Approvals (USA and Canada) Nonincendive (Notes 6, 7)					EC
IEC Intrinsic Safety II 1 G and II 1/2 G Ex ia IIC T6; II 1 D Ex iaD 20 T 95 °C and II 1/2D Ex iaD 21 T95 °C (Notes 6, 7)					E8
IEC Explosion Proof Group II Category 1/2 G Ex d IIC T6 and Group II Cat. 1/2 D Ex tD A21 IP67 T85 °C (Notes 2, 6, 7, 8)					E9
IEC Group II Category 3 G Ex nL IIC T6 and Group II Category 3 D Ex tD A22 IP67 T85 °C (Notes 6, 7)					ER
Combined IEC - Intrinsic Safety, Explosion Proof and Type „N“ (Notes 6, 7, 8, 9)					EI
Combined IEC - Intrinsic Safety and Explosion Proof (Notes 6, 7, 8, 9)					EH
NEPSI Intrinsic Safety Ex ia IIC T4~T6, DIP A20TA, T4~T6 (Notes 6, 7, 11)					EY
NEPSI Explosion Proof Ex d IIC T6, DIP A21TA, T6 (Notes 2, 6, 7, 8, 11)					EZ
NEPSI Type „N“ Ex nL IIC T4~T6, DIP A22TA, TT6 (Notes 6, 7, 11)					ES
Combined NEPSI - Intrinsic Safety, Explosion Proof and Type „N“ (Notes 6, 7, 8, 9, 11)					EQ
Combined NEPSI - Intrinsic Safety and Explosion Proof (Notes 6, 7, 8, 9, 11)					EP
<b>Other hazardous area certifications</b>					
GOST (Russia) Ex ia (Notes 6, 7, 11)					W1
GOST (Russia) Ex d (Notes 2, 6, 7, 8, 11)					W2
GOST (Kazakhstan) Ex ia (Notes 6, 7, 11)					W3
GOST (Kazakhstan) Ex d (Notes 2, 6, 7, 8, 11)					W4
Inmetro (Brazil) Ex ia (Notes 6, 7, 11)					W5
Inmetro (Brazil) Ex d (Notes 2, 6, 7, 8, 11)					W6
Inmetro (Brazil) Ex nL (Notes 6, 7, 11)					W7
Combined Inmetro (Brazil) - Intrinsic Safety, Explosion Proof and Type „N“ (Notes 6, 7, 8, 9, 11)					W8
GOST (Belarus) Ex ia (Notes 6, 7, 11)					WF
GOST (Belarus) Ex d (Notes 2, 6, 7, 8, 11)					WG
Combined GOST (Belarus) - Intrinsic Safety and Explosion Proof (Notes 6, 7, 8, 9, 11)					WH
<b>Integral LCD</b>					
Digital LCD integral display					L1
TTG (Through-The-Glass) digital LCD controlled display					L5
<b>Mounting bracket (shape and material)</b>					
For pipe/wall mounting - Carbon steel (Not suitable for AISI housing)					B6
For pipe/wall mounting - AISI 316 L ss					B7
<b>Surge</b>					
Surge/Transient Protector					S2

# Model 266GSH Gauge

## Model 266ASH Absolute

<b>ADDITIONAL ORDERING INFORMATION for model 266GSH</b>	XX	XX	XX	XX	XX	XX
<b>Operating manual (up to 2 different selections allowed)</b>						
German (ONLY FOR HART and PROFIBUS VERSIONS)	M1					
Italian (ONLY FOR HART VERSION)	M2					
Spanish (ONLY FOR HART VERSION)	M3					
French (ONLY FOR HART VERSION)	M4					
English	M5					
Chinese (ONLY FOR HART VERSION)	M6					
Swedish (ONLY FOR HART VERSION)	M7					
Polish (ONLY FOR HART VERSION)	M9					
Portuguese (ONLY FOR HART VERSION)	MA					
Turkish (ONLY FOR HART VERSION)	MT					
<b>Plates language</b>						
German	T1					
Italian	T2					
Spanish	T3					
French	T4					
<b>Additional tag plate</b>						
Supplemental wired-on stainless steel plate				I1		
Laser printing of tag on stainless steel plate				I2		
<b>Configuration</b>						
Standard – Pressure = inH2O/ psi at 68 °F; Temperature = deg. F					N2	
Standard – Pressure = inH2O/ psi at 39.2 °F; Temperature = deg. F					N3	
Standard – Pressure = inH2O/ psi at 20 °C; Temperature = deg. C					N4	
Standard – Pressure = inH2O/ psi at 4 °C; Temperature = deg. C					N5	
Custom					N6	
<b>Preparation procedure</b>						
Oxygen service cleaning (only available with inert fill and Viton gasket)				(Note 11)		P1
Pmax = 21 MPa for Galden or sensor overpressure, whichever is less; Tmax=60 °C/140 °F						
<b>Certificates (up to 2 different selections allowed)</b>						
Inspection certificate EN 10204–3.1 of calibration (9-point)						C1
Inspection certificate EN 10204–3.1 of the cleanliness stage						C3
Inspection certificate EN 10204–3.1 of helium leakage test of the sensor module						C4
Inspection certificate EN 10204–3.1 of the pressure test						C5
Certificate of compliance with the order EN 10204–2.1 of instrument design						C6
Overfill protection						C9
Printed record of configured data of transmitter						CG
PMI test of wetted parts						CT

ADDITIONAL ORDERING INFORMATION FOR MODEL 266GSH				XX	XX	XX	XX
<b>Approvals</b>							
GOST (Russia) without Ex	(NOT APPLICABLE WITH ANY HAZARDOUS AREA CERTIFICATION)	(Note 11)	Y1				
GOST (Kazakhstan) without Ex	(NOT APPLICABLE WITH ANY HAZARDOUS AREA CERTIFICATION)	(Note 11)	Y2				
GOST (Belarus) without Ex	(NOT APPLICABLE WITH ANY HAZARDOUS AREA CERTIFICATION)	(Note 11)	Y4				
Chinese pattern without Ex	(NOT APPLICABLE WITH ANY HAZARDOUS AREA CERTIFICATION)	(Note 11)	Y5				
DNV approval		(Note 11)		YA			
Lloyd approval (PENDING)		(Note 11)		YB			
Approval for Custody transfer (PENDING)		(Note 11)		YC			
<b>Material traceability</b>							
Certificate of compliance with the order EN 10204–2.1 of process wetted parts							H1
Inspection certificate EN 10204–3.1 of process wetted parts							H3
Test report EN 10204–2.2 of pressure bearing and process wetted parts							H4
<b>Connector</b>							
Fieldbus 7/8 in. (Recommended for FOUNDATION Fieldbus) - (supplied loose without mating female plug)		(Notes 7, 10)					U1
Fieldbus M12x1 (Recommended for PROFIBUS PA) - (supplied loose without mating female plug)		(Notes 7, 10)					U2
Harting Han 8D – straight entry - (supplied loose)		(Notes 6, 10)					U3
Harting Han 8D – angle entry - (supplied loose)		(Notes 6, 10)					U4

Note 1: Suitable for oxygen service

Note 2: Not available with Sensor C, F

Note 3: Not used

Note 4: Not available with Sensor L, D, U, R, V

Note 5: Select type in additional ordering code

Note 6: Not available with Housing code G, Z, W

Note 7: Not available with Housing code E, K

Note 8: Not available with Housing code J, K, W

Note 9: Not Ex d for sensor code C, F

Note 10: Not available with Housing code, A, B, S, T, J

Note 11: Not available with Sensor code Z

Note 12: Not available with Sensor C, F, L, D, U, R, V

Note 13: Not available with Sensor code C, V, Z

### Standard delivery items (can be differently specified by additional ordering code)

- General purpose (no electrical certification)
- No display, no mounting bracket, no surge protection
- Multilanguage short-form operating instruction manual and labels in english
- Configuration with kPa and deg. C units
- No test, inspection or material traceability certificates

# Model 266GSH Gauge

## Model 266ASH Absolute

### BASIC ORDERING INFORMATION model 266ASH Absolute Pressure Transmitter

Select one character or set of characters from each category and specify complete catalog number.

Refer to additional ordering information and specify one or more codes for each transmitter if additional options are required.

BASE MODEL - 1 <sup>st</sup> to 6 <sup>th</sup> characters			2	6	A	S	H	X	X	X	X	X	X
Absolute Pressure Transmitter – BASE ACCURACY 0.075 %													
SENSOR - Span limits - 7 <sup>th</sup> characters													
0.3 and 6 kPa	3 and 60 mbar	2.25 and 45 mmHg						C					
2 and 40 kPa	20 and 400 mbar	15 and 300 mmHg						F					
12.5 and 250 kPa	125 and 2500 mbar	93.8 and 1875 mmHg						L					
50 and 1000 kPa	0.5 and 10 bar	7.25 and 145 psi						D					
150 and 3000 kPa	1.5 and 30 bar	21.7 and 435 psi						U					
Diaphragm material / Fill fluid (wetted parts) - 8 <sup>th</sup> character													
Hastelloy C276™		Silicone oil	(Note 2)					NACE	K				
Hastelloy C276™gold-plated		Silicone oil	(Note 2)					NACE	G				
Hastelloy C276™		Inert fluid - Galden	(Notes 1, 2)					NACE	F				
Hastelloy C276™gold-plated		Inert fluid - Galden	(Notes 1, 2)					NACE	E				
Hastelloy C276™		White oil (FDA)	(Note 2)					NACE	Z				
Ceramic		No filling	(Note 4)					NACE	J				

continued  
see next page

BASIC ORDERING INFORMATION model 266ASH Absolute Pressure Transmitter				2	6	A	S	H	X	X	X	X
<b>Process connection (wetted parts) - 9<sup>th</sup> character</b>												
AISI 316 L ss	1/2 – 14 NPT-f female	NACE	B									
AISI 316 L ss	1/2 – 14 NPT-f male	NACE	T									
AISI 316 L ss	DIN EN837-1 G 1/2 B	NACE	P									
Hastelloy C-276™	1/2 – 14 NPT-f female	NACE	E									
Hastelloy C-276™	1/2 – 14 NPT-f male	NACE	K									
Hastelloy C-276™	DIN EN837-1 G 1/2 B	NACE	D									
<b>Gasket - 10<sup>th</sup> character</b>												
Viton™		(Notes 1, 4)								5		
Perfluoroelastomer (MWP = 0.6 MPa)		(Note 4)								6		
Perbunan		(Note 4)								8		
None		(Note 2)								N		
<b>Housing material and electrical connection - 11<sup>th</sup> character</b>												
Aluminium alloy ( barrel version)	1/2 – 14 NPT											A
Aluminium alloy ( barrel version)	M20 x 1.5 (CM 20)											B
Aluminium alloy ( barrel version)	Harting Han 8D connector	(general purpose only)	(Note 5)									E
Aluminium alloy ( barrel version)	Fieldbus connector	(general purpose only)	(Note 5)									G
AISI 316 L ss ( barrel version)	1/2 – 14 NPT											S
AISI 316 L ss ( barrel version)	M20 x 1.5 (CM20)											T
AISI 316 L ss ( barrel version)	Fieldbus connector	(general purpose only)	(Note 5)									Z
Aluminium alloy (DIN version)	M20 x 1.5 (CM20)	(not Ex d or XP)										J
Aluminium alloy (DIN version)	Harting Han 8D connector	(general purpose only)	(Note 5)									K
Aluminium alloy (DIN version)	Fieldbus connector	(general purpose only)	(Note 5)									W
<b>Output/Additional options - 12<sup>th</sup> character</b>												
HART digital communication and 4 to 20 mA	No additional options		(Notes 6, 7)									H
HART digital communication and 4 to 20 mA	Options requested by "Additional ordering code"		(Note 6)									1
PROFIBUS PA	No additional options		(Notes 6, 7)									P
PROFIBUS PA	Options requested by "Additional ordering code"		(Note 7)									2
FOUNDATION Fieldbus	No additional options		(Notes 6, 7)									F
FOUNDATION Fieldbus	Options requested by "Additional ordering code"		(Note 7)									3
HART and 4 to 20 mA Safety - certified to IEC 61508	No additional options		(Notes 6, 7)									T
HART and 4 to 20 mA Safety - certified to IEC 61508	Options requested by "Additional ordering code"		(Note 6)									8

# Model 266GSH Gauge

# Model 266ASH Absolute

## ADDITIONAL ORDERING INFORMATION for model 266ASH

Add one or more 2-digit code(s) after the basic ordering information to select all required options

	XX	XX	XX	XX
<b>Hazardous area certifications</b>				
ATEX Intrinsic Safety II 1 G and II 1/2 G Ex ia IIC T6; II 1 D Ex iaD 20 T 95 °C and II 1/2D Ex iaD 21 T95 °C	(Notes 6, 7)	E1		
ATEX Explosion Proof Group II Category 1/2 G Ex d IIC T6 and Group II Category 1/2 D Ex tD A21 IP67 T85 °C	(Notes 2, 6, 7, 8)	E2		
ATEX Type „N“ Group II Category 3 G Ex nL IIC T6 and Group II Category 3 D Ex tD A22 IP67 T85 °C	(Notes 6, 7)	E3		
Combined ATEX - Intrinsic Safety, Explosion Proof and Type „N“	(Notes 6, 7, 8, 9)	EW		
Combined ATEX - Intrinsic Safety and Explosion Proof	(Notes 6, 7, 8, 9)	E7		
Combined ATEX, FM Approvals (USA) and FM Approvals (Canada)	(Notes 6, 7, 8, 9)	EN		
FM Approvals (Canada) approval	(Notes 6, 7, 8, 9)	E4		
FM Approvals (USA) approval	(Notes 6, 7, 8, 9)	E6		
FM Approvals (USA and Canada) Intrinsic Safety	(Notes 6, 7)	EA		
FM Approvals (USA and Canada) Explosion Proof	(Notes 2, 6, 7, 8)	EB		
FM Approvals (USA and Canada) Nonincendive	(Notes 6, 7)	EC		
IEC Intrinsic Safety II 1 G and II 1/2 G Ex ia IIC T6; II 1 D Ex iaD 20 T 95 °C and II 1/2D Ex iaD 21 T95 °C	(Notes 6, 7)	E8		
IEC Explosion Proof Group II Category 1/2 G Ex d IIC T6 and Group II Category 1/2 D Ex tD A21 IP67 T85 °C	(Notes 2, 6, 7, 8)	E9		
IEC Group II Category 3 G Ex nL IIC T6 and Group II Category 3 D Ex tD A22 IP67 T85 °C	(Notes 6, 7)	ER		
Combined IEC - Intrinsic Safety, Explosion Proof and Type „N“	(Notes 6, 7, 8, 9)	EI		
Combined IEC - Intrinsic Safety and Explosion Proof	(Notes 6, 7, 8, 9)	EH		
NEPSI Intrinsic Safety Ex ia IIC T4~T6, DIP A20TA, T4~T6	(Notes 6, 7)	EY		
NEPSI Explosion Proof Ex d IIC T6, DIP A21TA, T6	(Notes 2, 6, 7, 8)	EZ		
NEPSI Type „N“ Ex nL IIC T4~T6, DIP A22TA, TT6	(Notes 6, 7)	ES		
Combined NEPSI - Intrinsic Safety, Explosion Proof and Type „N“	(Notes 6, 7, 8, 9)	EQ		
Combined NEPSI - Intrinsic Safety and Explosion Proof	(Notes 6, 7, 8, 9)	EP		
<b>Other hazardous area certifications</b>				
GOST (Russia) Ex ia	(Notes 5, 6)	W1		
GOST (Russia) Ex d	(Notes 2, 6, 7, 8)	W2		
GOST (Kazakhstan) Ex ia	(Notes 6, 7)	W3		
GOST (Kazakhstan) Ex d	(Notes 2, 6, 7, 8)	W4		
Inmetro (Brazil) Ex ia	(Notes 6, 7)	W5		
Inmetro (Brazil) Ex d	(Notes 2, 6, 7, 8)	W6		
Inmetro (Brazil) Ex nL	(Notes 6, 7)	W7		
Combined Inmetro (Brazil) - Intrinsic Safety, Explosion Proof and Type „N“	(Notes 6, 7, 8, 9)	W8		
GOST (Belarus) Ex ia	(Notes 6, 7)	WF		
GOST (Belarus) Ex d	(Notes 2, 6, 7, 8)	WG		
Combined GOST (Belarus) - Intrinsic Safety and Explosion Proof	(Notes 6, 7, 8, 9)	WH		
<b>Integral LCD</b>				
Digital LCD integral display			L1	
TTG (Through-The-Glass) digital LCD controlled display			L5	
<b>Mounting bracket (shape and material)</b>				
For pipe/wall mounting - Carbon steel	(Not suitable for AISI housing)			B6
For pipe/wall mounting - AISI 316 L ss				B7
<b>Surge</b>				
Surge/Transient Protector				S2



<b>ADDITIONAL ORDERING INFORMATION for model 266ASH</b>	<b>XX</b>	<b>XX</b>	<b>XX</b>	<b>XX</b>	<b>XX</b>	<b>XX</b>
<b>Operating manual (up to 2 different selections allowed)</b>						
German (ONLY FOR HART and PROFIBUS VERSIONS)	M1					
Italian (ONLY FOR HART VERSION)	M2					
Spanish (ONLY FOR HART VERSION)	M3					
French (ONLY FOR HART VERSION)	M4					
English	M5					
Chinese (ONLY FOR HART VERSION)	M6					
Swedish (ONLY FOR HART VERSION)	M7					
Polish (ONLY FOR HART VERSION)	M9					
Portuguese (ONLY FOR HART VERSION)	MA					
Turkish (ONLY FOR HART VERSION)	MT					
<b>Plates language</b>						
German		T1				
Italian		T2				
Spanish		T3				
French		T4				
<b>Additional tag plate</b>						
Supplemental wired-on stainless steel plate					I1	
Laser printing of tag on stainless steel plate					I2	
<b>Configuration</b>						
Standard – Pressure = inH2O/ psi at 20 °C; Temperature = deg. F						N2
Standard – Pressure = inH2O/ psi at 4 °C; Temperature = deg. F						N3
Standard – Pressure = inH2O/ psi at 20 °C; Temperature = deg. C						N4
Standard – Pressure = inH2O/ psi at 4 °C; Temperature = deg. C						N5
Custom						N6
<b>Preparation procedure</b>						
Oxygen service cleaning (only available with inert fill)						P1
Pmax = 21 MPa for Galden or sensor overpressure, whichever il less; Tmax=60 °C/140 °F						
<b>Certificates (up to 2 different selections allowed)</b>						
Inspection certificate EN 10204–3.1 of calibration (9-point)						C1
Inspection certificate EN 10204–3.1 of the cleanliness stage						C3
Inspection certificate EN 10204–3.1 of helium leakage test of the sensor module						C4
Inspection certificate EN 10204–3.1 of the pressure test						C5
Certificate of compliance with the order EN 10204–2.1 of instrument design						C6
Overfill protection						C9
Printed record of configured data of transmitter						CG
PMI test of wetted parts						CT

# Model 266GSH Gauge

## Model 266ASH Absolute

ADDITIONAL ORDERING INFORMATION FOR MODEL 266ASH		XX	XX	XX	XX
<b>Approvals</b>					
GOST (Russia) without Ex	(NOT APPLICABLE WITH ANY HAZARDOUS AREA CERTIFICATION)	Y1			
GOST (Kazakhstan) without Ex	(NOT APPLICABLE WITH ANY HAZARDOUS AREA CERTIFICATION)	Y2			
GOST (Belarus) without Ex	(NOT APPLICABLE WITH ANY HAZARDOUS AREA CERTIFICATION)	Y4			
Chinese pattern without Ex	(NOT APPLICABLE WITH ANY HAZARDOUS AREA CERTIFICATION)	Y5			
DNV approval			YA		
Lloyd approval (PENDING)			YB		
Approval for Custody transfer (PENDING)			YC		
<b>Material traceability</b>					
Certificate of compliance with the order EN 10204–2.1 of process wetted parts					H1
Inspection certificate EN 10204–3.1 of process wetted parts					H3
Test report EN 10204–2.2 of pressure bearing and process wetted parts					H4
<b>Connector</b>					
Fieldbus 7/8 in. (Recommended for FOUNDATION Fieldbus) - (supplied loose without mating female plug)		(Notes 7, 10)			U1
Fieldbus M12x1 (Recommended for PROFIBUS PA) - (supplied loose without mating female plug)		(Notes 7, 10)			U2
Harting Han 8D – straight entry - (supplied loose)		(Notes 6, 10)			U3
Harting Han 8D – angle entry - (supplied loose)		(Notes 6, 10)			U4

Note 1: Suitable for oxygen service

Note 2: Not available with Sensor C, F

Note 3: Not used

Note 4: Not available with Sensor L, D, U

Note 5: Select type in additional ordering code

Note 6: Not available with Housing code G, Z, W

Note 7: Not available with Housing code E, K

Note 8: Not available with Housing code J, K, W

Note 9: Not Ex d for sensor code C, F

Note 10: Not available with Housing code, A, B, S, T, J

### Standard delivery items (can be differently specified by additional ordering code)

- General purpose (no electrical certification)
- No display, no mounting bracket, no surge protection
- Multilanguage short-form operating instruction manual and labels in english
- Configuration with kPa and deg. C units
- No test, inspection or material traceability certificates

### IMPORTANT REMARK FOR ALL MODELS

THE SELECTION OF SUITABLE WETTED PARTS AND FILLING FLUID FOR COMPATIBILITY WITH THE PROCESS MEDIA IS A CUSTOMER'S RESPONSIBILITY, IF NOT OTHERWISE NOTIFIED BEFORE MANUFACTURING.

### NACE COMPLIANCE INFORMATION

- (1) The materials of constructions comply with metallurgical recommendations of NACE MR0175/ISO 15156 for sour oil field production environments. As specific environmental limits may apply to certain materials, please consult latest standard for further details. Selected materials also conform to NACE MR0103 for sour refining environments.
- (2) NACE MR-01-75 addresses bolting requirements in two classes:
  - Exposed bolts: bolts directly exposed to the sour environment or buried, encapsulated or anyway not exposed to atmosphere
  - Non exposed bolts: bolts exposed to the atmosphere.
 266 bolting identified by "NACE" are in compliance to the requirements of NACE MR-01-75 when considered "exposed bolting"



# Contact us

## **ABB Ltd.**

### **Process Automation**

Howard Road  
St. Neots  
Cambridgeshire PE19 8EU  
UK

Tel: +44 (0)1480 475321

Fax: +44 (0)1480 217948

## **ABB Inc.**

### **Process Automation**

125 E. County Line Road  
Warminster  
PA 18974  
USA

Tel: +1 215 674 6000

Fax: +1 215 674 7183

## **ABB Automation Products GmbH**

### **Process Automation**

Schillerstr. 72  
32425 Minden  
Germany

Tel: +49 551 905 534

Fax: +49 551 905 555

## **ABB S.p.A.**

### **Process Automation**

Via Statale 113  
22016 Lenno (CO)  
Italy

Tel: +39 0344 58111

Fax: +39 0344 56278

[www.abb.com](http://www.abb.com)

## Note

We reserve the right to make technical changes or modify the contents of this document without prior notice. With regard to purchase orders, the agreed particulars shall prevail. ABB does not accept any responsibility whatsoever for potential errors or possible lack of information in this document.

We reserve all rights in this document and in the subject matter and illustrations contained therein. Any reproduction, disclosure to third parties or utilization of its contents - in whole or in parts - is forbidden without prior written consent of ABB.

Copyright© 2012 ABB

All rights reserved

3KXP200012R1001

<sup>TM</sup> Hastelloy C-276 is a Cabot Corporation trademark

<sup>TM</sup> Inconel is a Special Metals Corporation trademark

<sup>TM</sup> Viton is a Dupont de Nemour trademark

<sup>TM</sup> Galden is a Montefluos trademark