

NOTES:

1. WARNING: This drawing does not illustrate the installation methods required for hazardous locations. Prior to any installation in a Classified Hazardous Location, verify installation methods by the Control Drawing referenced on the product's name tag and national and local codes.
2. WARNING: Using a non-factory RS232 data cable between uFLO and radio may result in damage and may void system warranty.

PRIMARY SETUP ITEMS FOR TRANSNET 900 RS-232 RADIOS:

1. Mode R.
2. ADDR XXXX - where (xxxx) is radio's address, which is also the same as the Master Radio's Address.
3. SLEEP ON.
4. Port RS232.
5. BAUD 9600 8,n,1 - (other baud rates and parity can be used but needs to match the flow computer).

Note: Typically, all other setup items can be left in their default state.

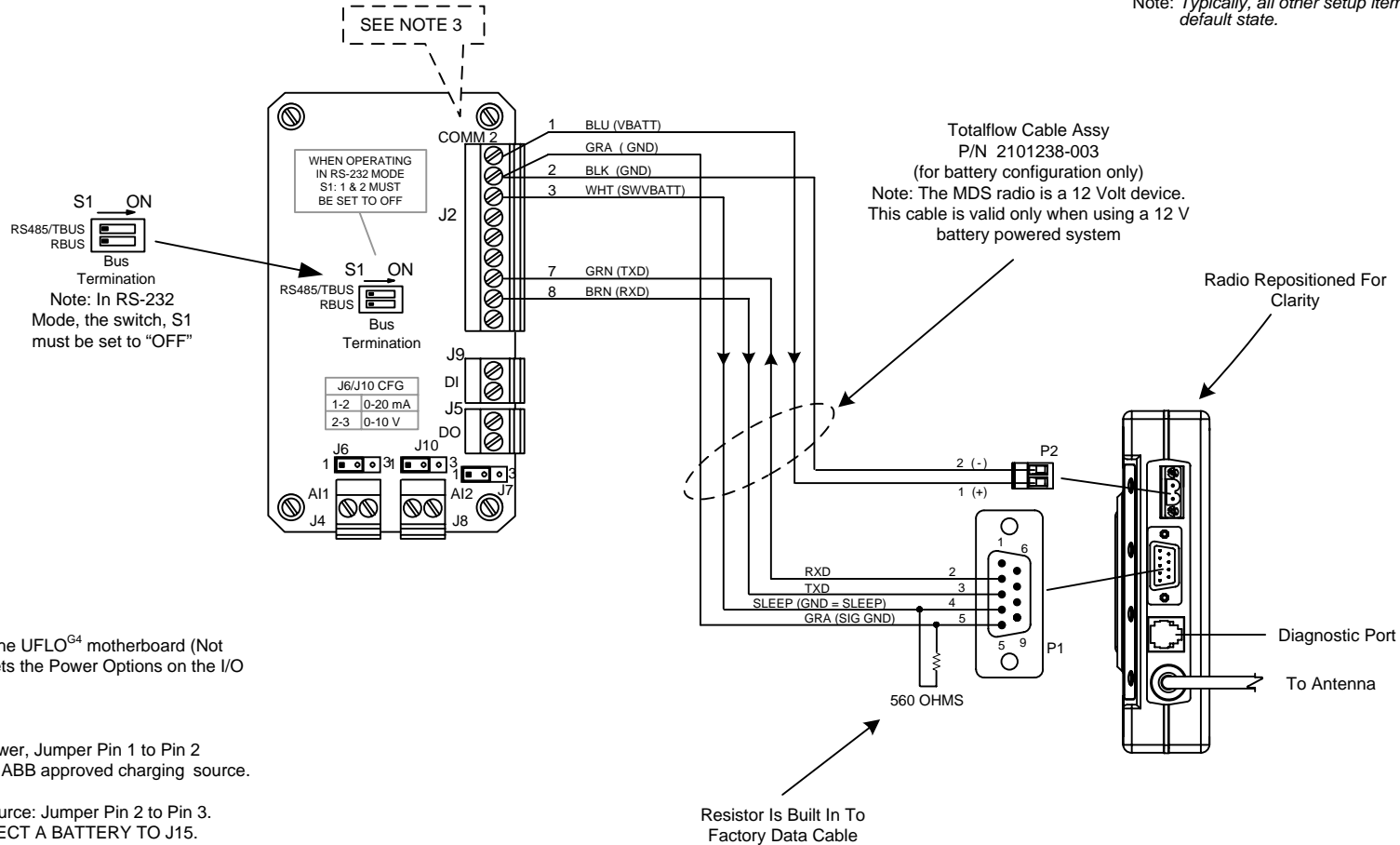

3. The Jumper at J16 of the uFLO<sup>G4</sup> motherboard (Not shown on this page) sets the Power Options on the I/O board:

On the motherboard:

For Solar & Battery Power, Jumper Pin 1 to Pin 2

**Note:** Power to J17 by ABB approved charging source.

For External Power Source: Jumper Pin 2 to Pin 3.

**Note:** DO NOT CONNECT A BATTERY TO J15.

Wire external power (9 - 30 Vdc) to charger connector J17.

WARNING: Power at J17 (up to 30 Vdc) is applied to the Communication connector terminals as power for radios, etc. Radio operation and the Inhibit feature may not work properly if other than a nominal 12 Vdc power source is utilized.

REF: N/A

	<b>TOTALFLOW</b> Products	ACTION	DOC TYPE	TITLE	DWG NO.	REV	SHEET
		D31823	UD	μFLO <sup>G4</sup> OPT1 I/O (2104395 BOARD) COMM2 TO MDS TRANSNET 900 RADIO (RS-232)	2104581	AB	1 OF 1