

MARINE & PORTS | SERVICE

# Optimizing energy usage

for heating, ventilation, air conditioning

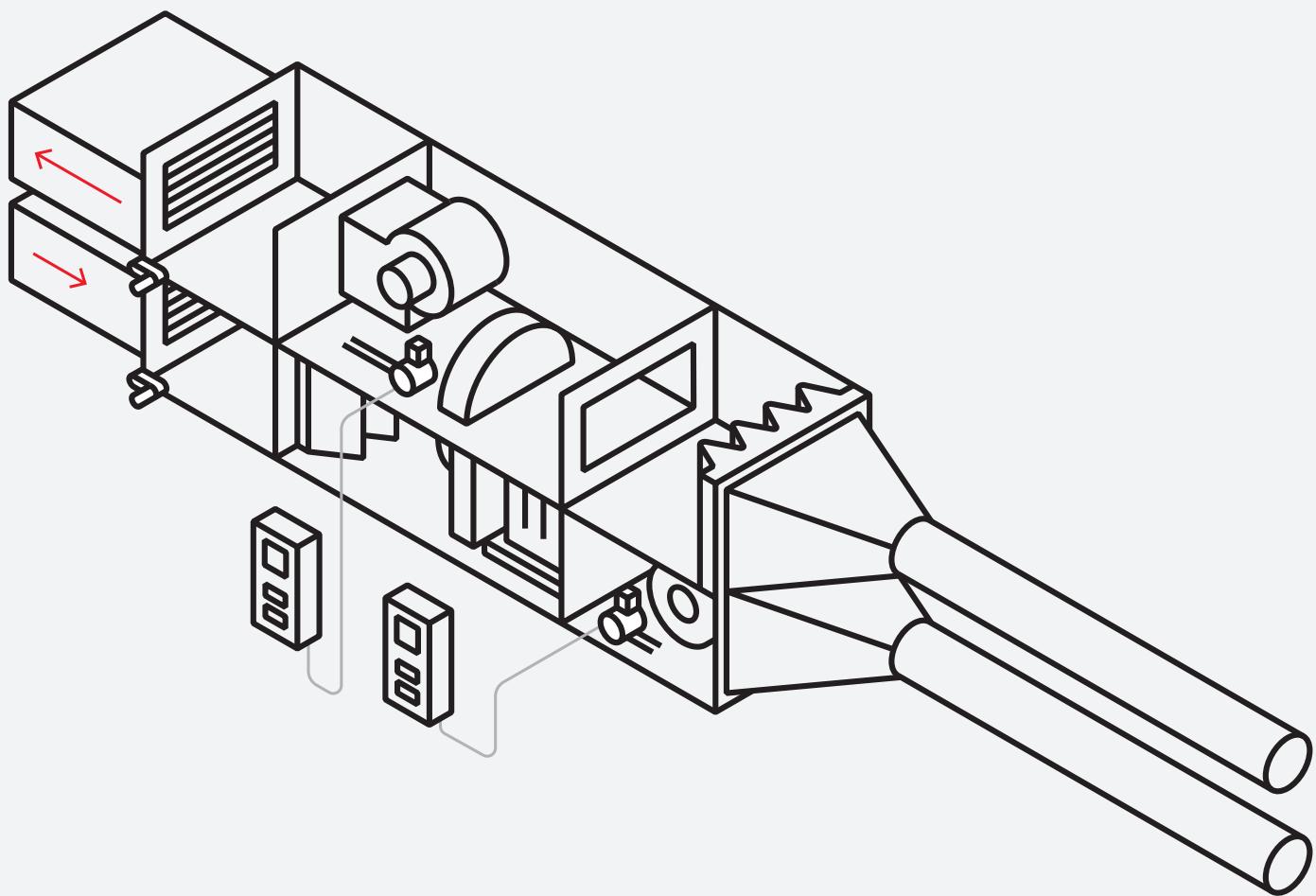

- Accurate process control based on the actual operating conditions, rather than on a theoretical design point of the process.
- Solutions for retrofitting existing cooling circuits.
- Running motors at reduced speed lowers energy consumption.

---

# Variable frequency drive to control HVAC systems

Heating, ventilation, and air conditioning (HVAC) are the second largest energy consumers after propulsion in passenger vessels. The HVAC system has three elements functioning separately.

Onboard HVAC systems are generally divided into three elements: the cooling system (chiller plant), chilled water circuit, as well as air handling units (AHU). Chiller plants play an important role in air conditioning systems, since they supply the air handling unit with chilled water. Onboard ships, the most commonly used chiller systems are vapor compressed refrigeration cycle chillers, comprising compressor, condenser, expansion or flow control devices, as well as evaporators.

The most commonly used compressors are screw or centrifugal types, with an indirect central cooling system design. This means that secondary circuits are also installed, where the condenser is cooled via a seawater cooling circuit and the chilled water circuit (evaporator side) uses cold water to cool the air handling units.

Consideration can be given to using a variable frequency drive (VFD) for the chilled water circuit in both variable flow and constant pressure systems. In practice, energy efficiency improvements are always achieved in cases where the existing system uses balancing valves to adjust either the flow or pressure. If the operational profile of the ship varies significantly during the year, it is worth considering whether to install VFD on seawater cooling pumps on the condenser side.

Several methods are available for capacity control of the centrifugal compressor, each of which has its advantages and disadvantages. Two of the most common capacity control methods are speed variation and pre rotation vanes, also known as inlet guide vanes. Pre rotation vanes modulate capacity by altering the direction of the refrigerant flow entering the impeller. Capacity control based on variable speed (with VFD) is more economical than pre rotation vanes, in applications where the pressure requirements vary under a part load.

Fans use approximately 40% of all electricity in HVAC systems. Despite the range of textbooks and handbooks on the issue, which describe the proper procedure for the selection of fans, practice shows that fans in existing HVAC systems have a very low overall efficiency.

Cooling and heating coils are located within the AHU. These coils are connected to a pre-heating or re-heating system, which uses a combination of pumps, fans and compressors. Incoming fresh air passes over these coils and is warmed or cooled, depending on the room-air quality requirements.

Using VFD for the speed control of fans provides an effective way of improving air quality and optimising energy use. Choosing ABB standard drives for HVAC provides users with ready-made macros for the most common HVAC applications, such as pumps, fans and condensers.

---

Cooling systems play an important part in air conditioning systems, since they supply air handling units (AHU) with chilled water. This water is circulated in the cooling coil located inside the AHU, in order to cool the supply air temperature.

### Benefits

- Accurate process control based on the actual operating conditions, rather than on a theoretical design point of the process.
- Solutions for retrofitting existing cooling circuits.
- Running motors at reduced speed lowers energy consumption.
- Precise control of air quality leads to a healthier and more comfortable environment
- Smooth control reduces mechanical stress on pumps, fans and compressors, while lowering maintenance costs.

### Savings and payback time

- Installing VFDs on chilled water pumps and on the evaporator cooling side provides accurate control and energy consumption based on process demand. In most cases, the typical payback time is less than one year. On average, savings are between 30 – 40% of total power consumption.
- Using VFDs for supply and exhaust fans, rather than relying on inlet vanes and two-speed motors, generates energy savings in every case. The payback time is less than one year.
- In theory, installing a VFD on a centrifugal compressor can reduce power consumption by as much as 25%. This depends heavily on the chiller plant's control strategy. The investment cost of a chiller upgrade is relatively high, generating a payback time of between 2 – 2.5 years.

—  
01 ABB Marine & Ports  
believes the next  
generation of ships  
are electric, digital  
and connected.

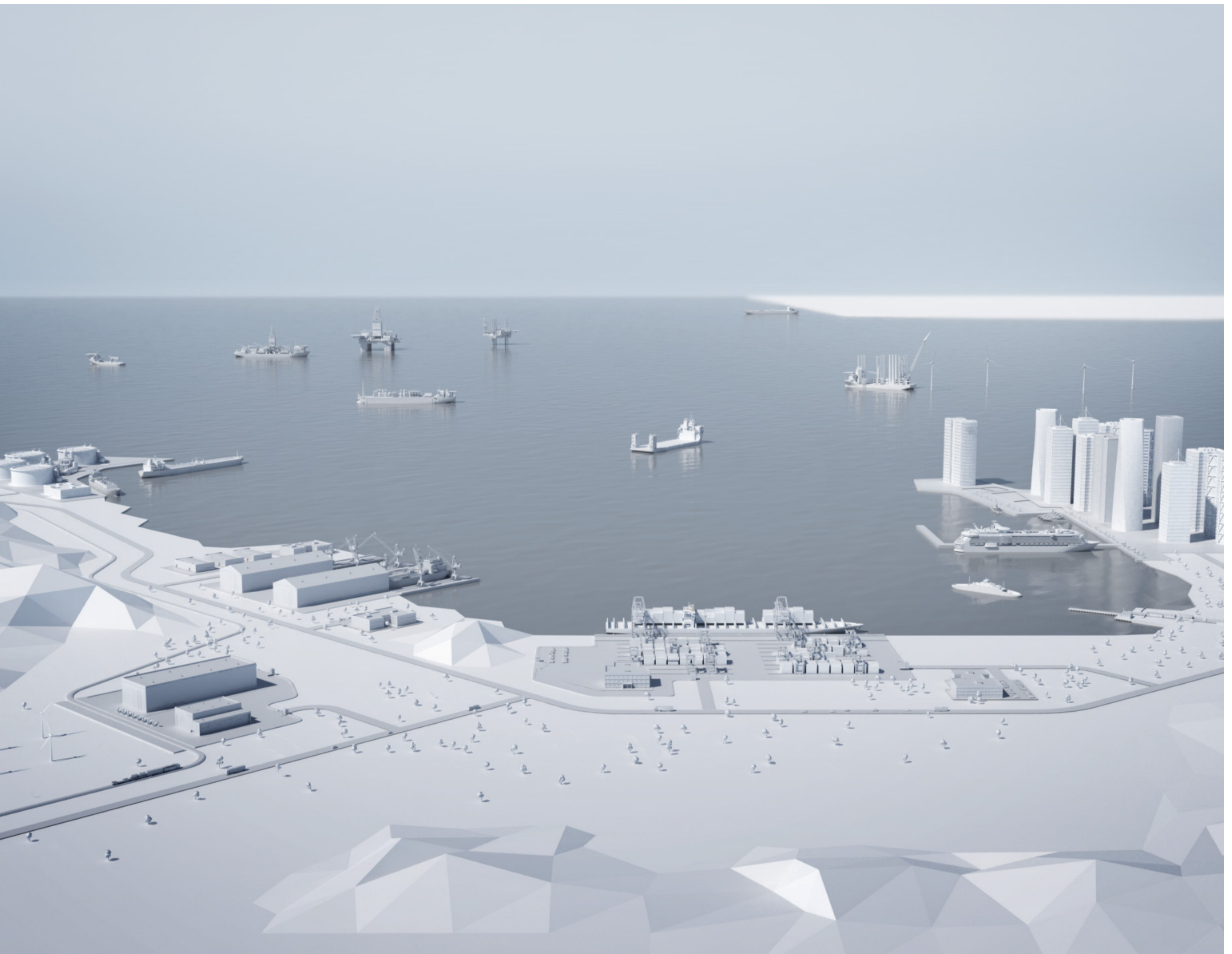

# HVAC

## Technical description

Heating, ventilation, and air conditioning are the second largest energy consumers after propulsion in passenger vessels. The HVAC system has three elements functioning separately.

Cooling systems play an important part in air conditioning systems, since they supply air handling units (AHU) with chilled water. This water is circulated in the cooling coil located inside the AHU, in order to cool the supply air temperature.

### Central cooling system, chiller

Central cooling systems can be divided into two major categories: vapour compression refrigeration cycle chillers and absorption-cycle chillers. These two methods rest on the same basic working principle, but use different refrigerants and a different compression method. While a vapour compression system is based on mechanical force (compressor) used to raise the pressure and the temperature of the refrigerant, an absorption-cycle chiller uses external heat to do the same.

Vapour compression refrigeration cycle chillers are the most commonly used method onboard ships. Absorption type chillers can be used in combination with waste heat from steam and/or high temperature (HT) cooling processes.

A vapour compression chiller has the following main components:

- Compressor
- Condenser
- Expansion or flow control device
- Evaporator

A compressor is used to compress refrigerant gas into a higher-pressure and higher-temperature gas. The condenser then cools down the gas and condenses it into liquid. The liquid is then routed through the expansion valve, where it undergoes a reduction in pressure and temperature. After this, the cold mixture is routed through the evaporator, where the liquid refrigerant is returned to gas form. Finally, the refrigerant gas enters the compressor and the cycle continues.

In the vapour compressor process, it is important to understand that the refrigerant can exist in gas and liquid form, depending on the temperature and pressure of the refrigerant. The refrigerant will phase change from liquid into gas or gas into liquid at the saturation temperature. A large amount of energy is exchanged during the phase change of the refrigerant. The saturation temperature is proportional to pressure, meaning that if the pressure is high, the saturation temperature will also be high and vice versa. It is important to understand this, since the compressor compresses the refrigerant gas to match the condenser saturation pressure, in such a way that the refrigerant gas can condense at a temperature equal to that at which water exits the condenser. Based on this, it is easy to understand why the compressor is controlled according to the discharge pressure and how the power required by the compressor is linked to the water temperature as it exits the condenser.

### System design

The central cooling system design can be either direct or indirect. In a direct system, the refrigerant directly transports heat from the cooled space to the space in which heat is released. In an indirect system, a heat exchanger is used to transfer heat between the primary circuit and one or two secondary circuits (condenser side or/and evaporator side). An indirect system with secondary circuits requires heat exchangers and circulation pumps for these secondary circuits. Simplified examples of direct and indirect systems can be seen in figure 3. The most common system onboard a ship is an indirect system, where the condenser is cooled via a seawater cooling circuit.

A central cooling system might also have more than one compressor in one chiller unit, or multiple chillers within the cooling system, either in series or in parallel. A chiller with multiple compressors is called a multi-stage chiller.

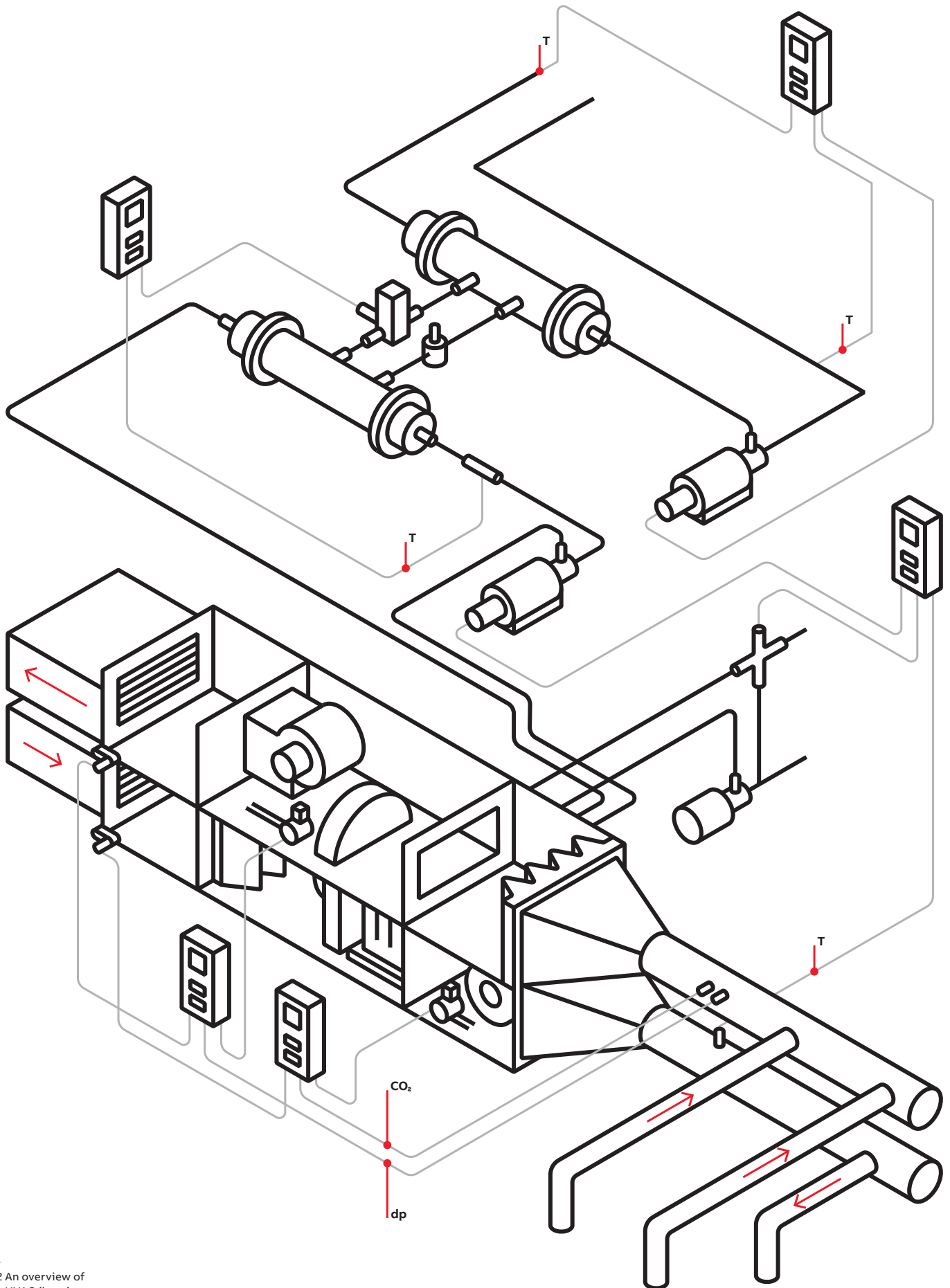

—  
 02 An overview of  
 an HVAC (heating,  
 ventilation and air  
 conditioning) system,  
 with an AHU and central  
 cooling system.

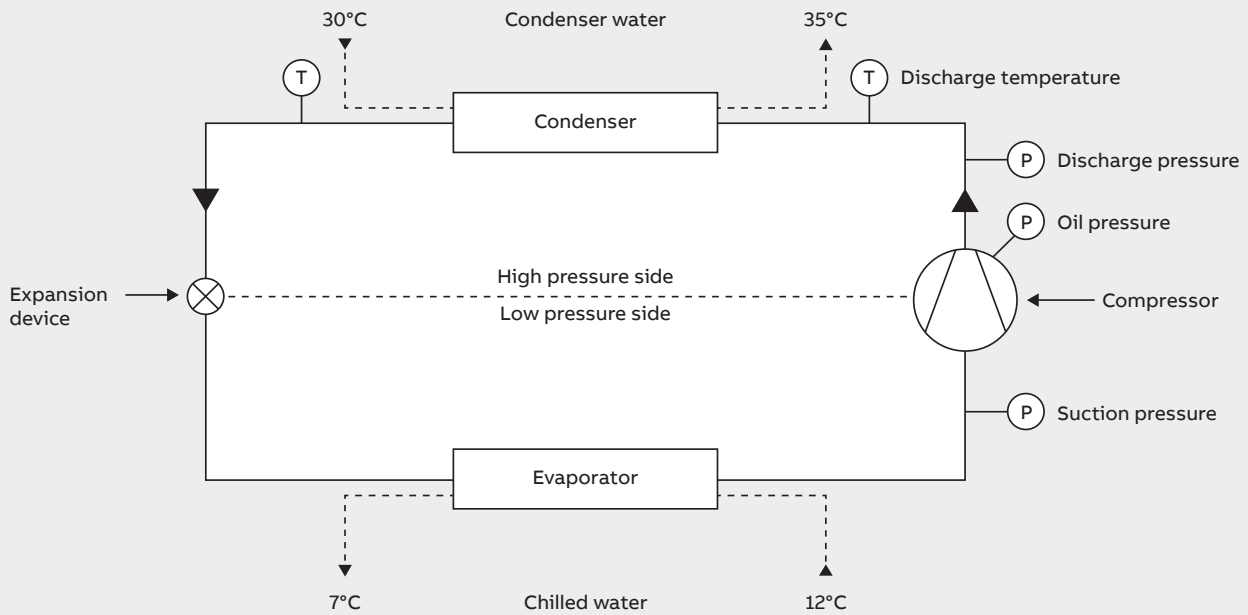

—  
03 Diagram for  
vapour compression  
chiller

### A variable chilled water flow and condenser water flow

A variable flow of chilled water and condenser water is achieved by varying the speed of the condenser pump and chilled water pump. The chilled water side can also be divided into primary and secondary sides, with their own circulation pumps. Primary and secondary circuits are more typically used when the central cooling system serves a group of areas with large cooling loads.

Consideration should be given to a variable flow on the chilled water side in cases where the cooling load varies significantly. Differential pressure measurement is used to control the chilled water pumps, in order to secure an adequate water flow, even at the system's remotest cooling coil.

Consideration could be given to using variable frequency drives (VFD) on the chilled water side, in both variable flow and constant pressure systems.

More often than not, a constant pressure system is over dimensioned for the need in hand, considering the fouling margins, and the pressure in the system is kept stable using manually controlled valves. Applying a VFD with fully opened valves, based on using the VFD to control pressure, is more energy efficient.

Savings in chilled water pumps are based on controlling the flow of the system, by using balancing valves, rather than a throttling system, to control the speed of the pump.

The actual power requirement of the circulation pumps is calculated based on the flow rate and pressure over the pump, according to the following formula:

$$P = q \times dP$$

Where  $q$  is the volume flow rate of the pump and  $dP$  is the pressure difference over the pump. The given pump power is theoretical and takes no account of efficiencies. On the other hand, no account is taken of the fouling margins of the piping design either, due to which using theoretical power as the base for the saving estimation is viewed as justified.

Energy savings of up to 30% can be achieved by using VFD to control the pumps, rather than controlling the process with balancing valves.

Onboard a ship, the chiller, particularly the condenser side, is dimensioned based on the ship's operating profile. For example, on a cruise ship cruising on the Caribbean, the condenser side must be dimensioned to a relatively high seawater temperature, typically 32-35°C. When the same ship cruises on European waters or in a colder climate, the temperature at which the water enters the system is lower than the dimensioned temperature, leaving room for variable flow in the seawater entering the condenser.

Applying a VFD to the seawater cooling pump, which ensures that the seawater flow rate is kept above the minimum flow rate approved by the chiller manufacturer (to avoid laminar flow and scaling), can reduce the flow by as much as 40%.

In a piping system where the flow is controlled by controlling the speed of the pump, the flow rate and the power requirement of the pump follow affinity laws, as described below

$$\frac{Q_1}{Q_2} = \frac{n_1}{n_2} \text{ and } \frac{P_1}{P_2} = \left(\frac{n_1}{n_2}\right)^3$$

Where Q is the flow rate of the system, n is the running speed of the pump and P is the pump's power requirement.

The affinity laws state that the power requirement increases by the velocity cubed, meaning that while even a small increase in speed requires much more power, a modest speed reduction can yield significant energy savings. Figure 4 illustrates how a pump or fan running at half speed consumes only one-eighth of the power of one running at full speed – by reducing the motor speed by 20 per cent, the required power can be lowered by up to 50 per cent.

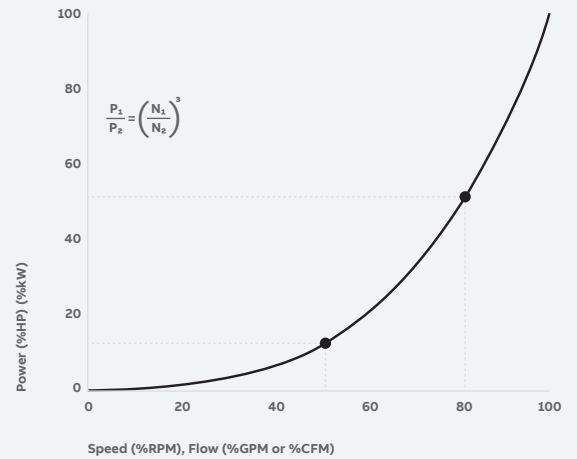

04 A pump or fan running at half speed consumes only one-eighth of the power

05 Direct system on the left and indirect system on the right

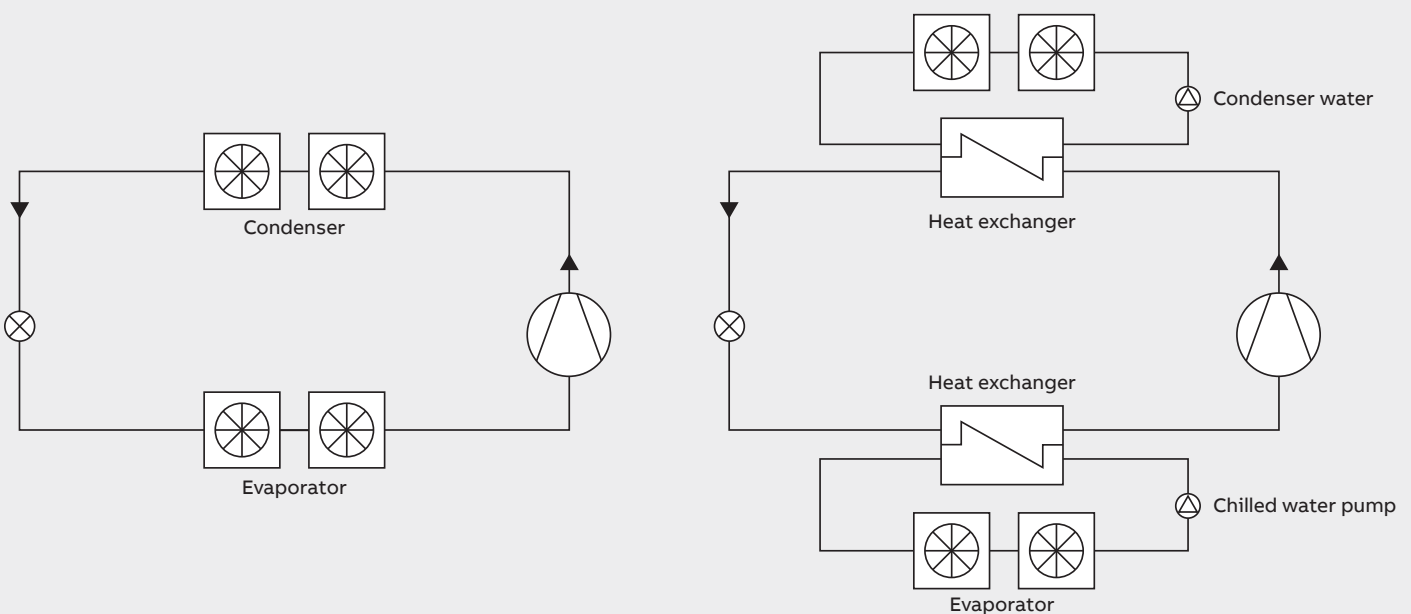



### Compressor types

Many types of compressors are available, with a range of characteristics. Compressors are typically divided, based on the compression mechanism used, into two broad categories: positive displacement and dynamic compressors.

Positive displacement compressors physically compress the vaporised refrigerant into higher pressures and smaller volumes, by reducing the volume of the compression chamber, while dynamic compressors increase vaporised refrigerant pressure, by the continuous transfer of kinetic energy to the refrigerant, using a rotating impeller.

Positive displacement compressors are relatively constant torque applications, while dynamic compressors are varying torque applications.

The most commonly used compressors for HVAC chillers are screw compressors, although the centrifugal type of compressor is becoming more common in new installations, due to the flexibility it brings to part load conditions, together with its variable speed (with VFD).

### Screw compressor

A screw compressor is a positive-displacement compressor that compresses using two meshing

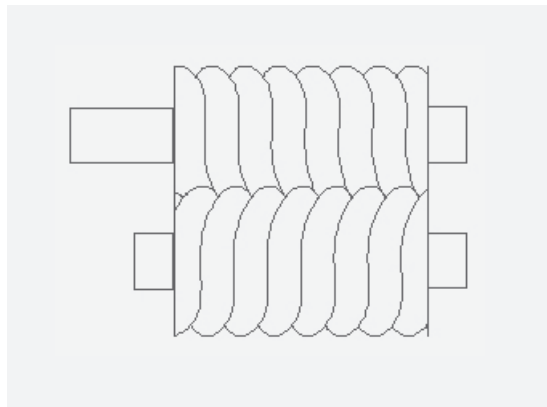

—  
Screw compressor

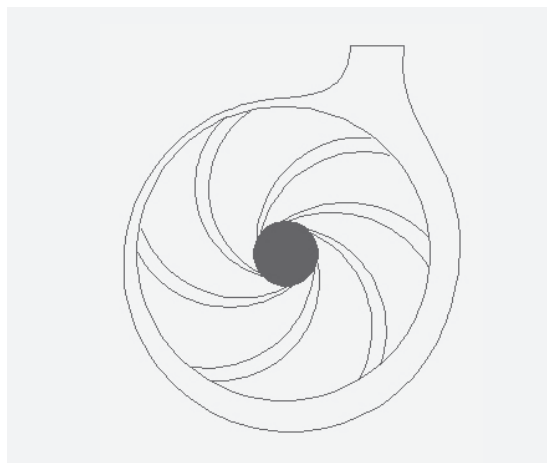

—  
Centrifugal compressor

helical screws, known as rotors. Screw compressors used in air conditioning and refrigeration applications are divided into two distinct screw compressor types: single-screw and twin-screw. A single-screw has only one main rotor, which works with a pair of gate rotors. Twin-screws have two helically grooved rotors that mesh closely together.

A screw compressor does not require suction and discharge valves and, in comparison to a reciprocating compressor, is considered compact, simple and reliable. Screw compressors are also capable of producing high pressure ratios at low suction pressure, meaning that a wide range can be achieved with a single stage compressor.

### Capacity control of screw compressors

Compression in screw compressors is obtained through a direct volume reduction, based on pure rotary movement. This means that capacity control of screw compressors can be achieved relatively simply, by varying the speed of the screw. The traditional speed modulation method has been suction throttling, achieved by opening and closing either a slide, slot or lift valve connected to compressor suction. Because a slide valve is most energy-efficient under a part load, it is also the most common solution. With a slide valve, it is possible to start the compressor unloaded and to run it at part loads, with a range of approximately 10% to 100%.

A screw compressor can only be rotated in one direction. This means that a cut-off valve is needed to stop the refrigerant flow, due to the pressure difference after shutdown.

### Centrifugal compressor

Centrifugal compressors, sometimes called turbo compressors, are dynamic compressors, meaning that they use a rotating impeller to transfer kinetic energy to refrigerant. This kinetic energy is then converted into a pressure increase by slowing the flow of the refrigerant through a diffuser.

Centrifugal compressors are most suitable for large refrigerant volumes at relatively low pressure. Higher pressure ratios require multiple stages, which add to their costs. A multistage compressor has two or more impellers mounted in the same casing, while a single stage compressor has only one impeller.

### Capacity control of centrifugal compressor

Several methods exist for the capacity control of centrifugal compressors. Each method has its own advantages and disadvantages. Two of the



most common methods are speed variation and prerotation vanes, also known as inlet guide vanes. Prerotation vanes modulate capacity by altering the direction of the refrigerant flow entering the impeller. Capacity control using variable speed is more economical than prerotation vanes, in applications where the pressure requirements vary under a part load. Variable speed control alone cannot reach areas with low flow and high head, because at low flow the compressor is unable to overcome the required lift causing the compressor to surge, in which case the refrigerant begins to flow back and forth inside the compressor. In practice, a combination of speed variation and prerotation vanes is typical, because this combines the advantages of both control methods.

The capacity control of centrifugal compressors is based on measurement of the chilled-liquid temperature, which is usually placed in thermal contact with the exiting chilled water. Consideration must be given to the starting torque, although on many occasions' prerotation vanes or suction throttling can to some extent be used for torque reduction.

**Applying a VFD to a centrifugal compressor**

When installing a VFD on a compressor, it is important to take account of all of the above facts. This is fairly simple when the chiller is being installed in a new installation. However, since it is known that chillers are a major consumer of energy onboard ships, major interest has arisen in using more efficient means to retrofit existing chillers.

Retrofitting an existing chiller is a demanding process. Chiller manufacturers typically play an important role in retrofits, by modifying the control logic of the compressor. Such modifications make sense in applications (ships) with large chillers.

In the case of a ship with a cooling load profile like to that in below graph 06, we can calculate the difference between power consumption when the same chiller unit is, or is not, equipped with a VFD. The chiller unit cooling capacity is 4,700 kW.

06 Cooling load profile of a ship

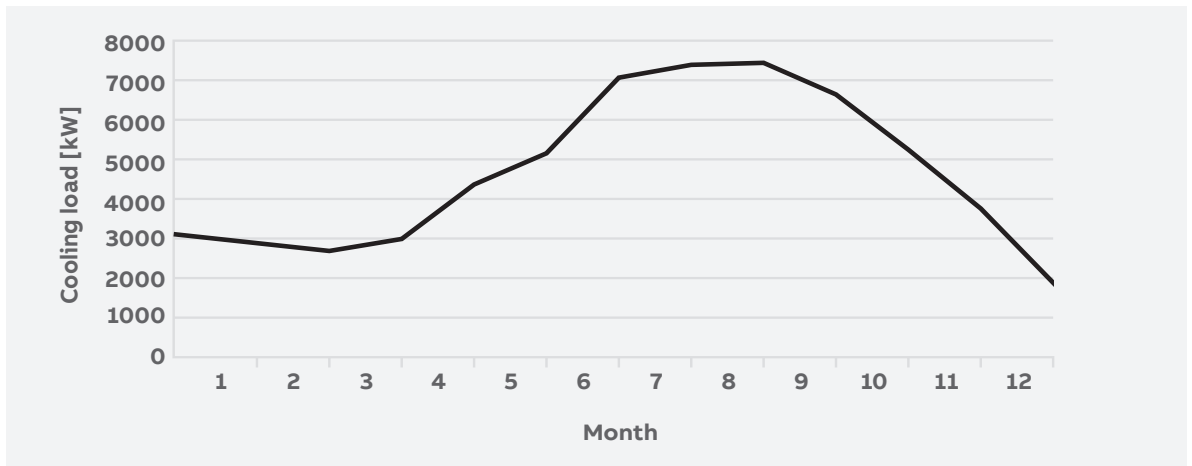

07 Mean COP versus loading profile

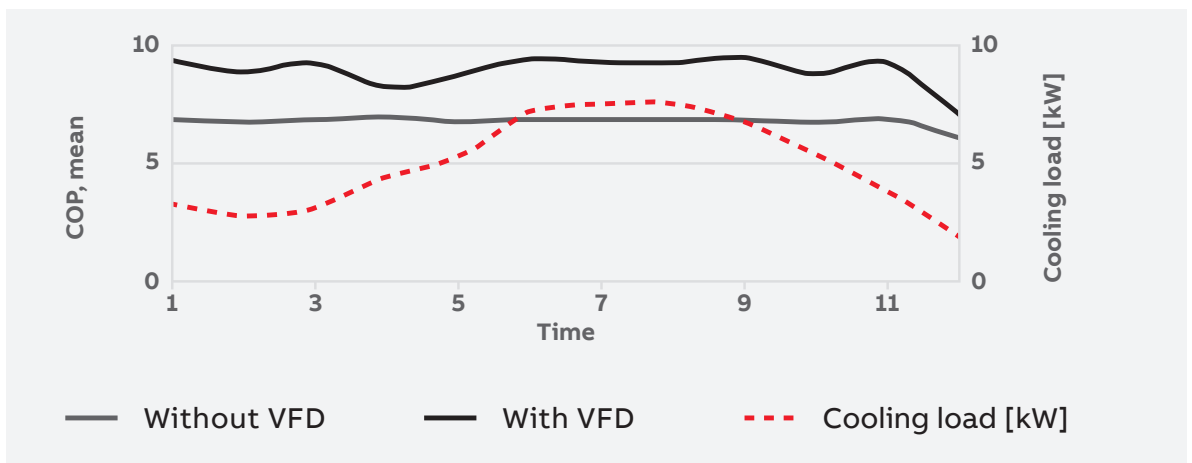

08 Energy demand versus loading profile

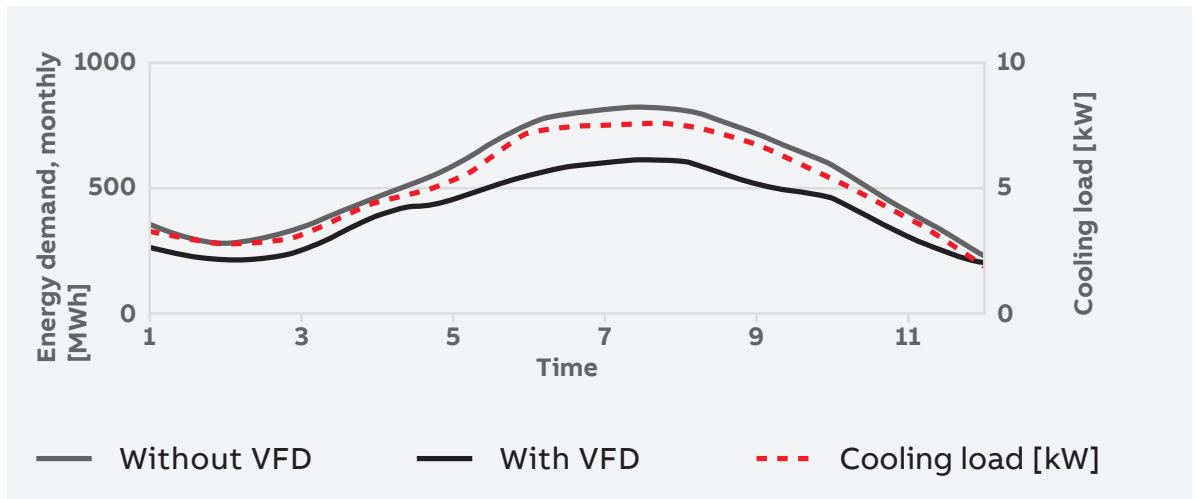

As can be seen from the graphs, there are differences in energy consumption, generating additional savings in the already energy-efficient compressor type.

Annual energy consumption without a VFD is 6,242 MWh, whereas the same chiller with VFD consumes 4,700 MWh, generating annual energy savings of 1,540 MWh. Converted into fuel, this energy consumption is equivalent to around 300 mt of fuel annually, providing a payback time of around two years.

Because compressor performance depends on so many factors, applying a variable speed drive to a compressor requires knowledge of the application in question.

#### Air Handling Units

Fans use approximately 40% of all electricity consumed by HVAC systems. Contrary to textbook advice on the proper procedure for the selection of fans, in practice the fans in existing HVAC systems have very low overall efficiency. In Sweden, ECIS AB (Energy Concept in Sweden) carried out performance measurements of 767 fans in existing HVAC systems, between the years 2005 and 2009. The average total efficiency was only 33%.

Today's best fans include an electric motor based on brushless direct current (DC) technology, also known as electronically commutated motors (EC motor), with an integrated frequency converter for step-less load control and an impeller with low aerodynamic losses. Fans should be direct-driven, i.e. the fan impeller should be directly mounted on the electric motor shaft. EC motors are not yet available for higher flow and pressure ranges, for which the best available motor technology is AC electric motors with an efficiency rating of IE3 when used with a VFD.

According to existing regulations on fans, the efficiency of fans must be given as the total efficiency of the fan assembly, i.e. including losses related to all components in the assembly: the

electric motor, the VFD, the belt drive (if given), the aerodynamic design, and the efficiency of the fan wheel.

Today, many AHUs installed on board ships use belt-driven motors for the supply and exhaust fan, in combination with one speed or two-speed motors. While two-speed motors provide greater flexibility in controlling the speed of the fan, the efficiency of a two-speed motor is relatively low. In addition to the two-speed configuration of the motor, guide vanes can be used to control the air flow. Of course, this reduces the flow, but at the expense of the low overall efficiency of the AHU.

The number of air handling units onboard a ferry varies between 15 – 40, depending on the size of the ship. In a cruise vessel, the number of air handling units can be as high as 70. Based on these figures, it is easy to see that such devices represent a large proportion of total energy consumption in HVAC systems. Such units function 24h a day, 7 days a week.

#### System design

In ships, an HVAC system maintains the desired air quality by controlling the temperature, pressure, humidity, air change and carbon dioxide (CO<sub>2</sub>) content. These properties are effectively controlled by an air handling unit.

AHUs feature supply and return air fans used to feed air into, and extract it from, the area in question. Air quality is measured using appropriate sensors located within the air ducts and throughout the ship. Measurements from these sensors determine the required fresh air flow.

Cooling and heating coils are located within the AHU. These coils are connected to a pre-heating or re-heating system, which use a combination of pumps, fans and compressors. Incoming fresh air passes over these coils and is warmed or cooled, depending on the room's air quality requirements.

Using VFD for the speed control of fans provides an effective way of improving air quality and optimising energy use. Using ABB standard drives for HVAC provides users with ready-made macros for the most common HVAC applications, such as pumps, fans and condensers.

#### Supply and return fans in air handling units

Supply and return fans can run at a constant speed, providing the desired static amount of fresh air flowing into the building. They can also run at a variable speed keeping, for instance, the pressure in the area constant or providing a certain flow of fresh air into the area, depending on the measured air property inside. Sensors measuring various air properties inside the ship can be connected directly to the I/O of the ABB standard drive for HVAC.

Many control strategies exist for air handling units, but no standard solution is available for increasing energy efficiency in such applications. If the existing installation uses inlet guide vanes and two-speed motors, huge potential exists for increasing energy efficiency, by installing VFDs on both the supply and exhaust fans. Speed control of VFDs should be based on a control strategy similar to that of the existing system. The speed reference can be temperature, pressure or CO<sub>2</sub>, depending on the area that needs to be cooled and ventilated. All of the various references can easily be used to control the speed of the VFD.

#### Benefits

- Accurate process control, based on the actual operating conditions rather than the theoretical design point of the process.
- Solutions for retrofitting existing cooling circuits
- Running motors at a reduced speed lowers energy consumption
- Precise control of air quality creates a healthier and more comfortable environment
- Smooth control reduces mechanical stress on pumps, fans and compressors, and leads to reduced maintenance costs

#### Savings and payback time

- Installing VFDs on chilled water pumps and the evaporator cooling side provides accurate control and energy consumption, based on process demand. In most cases, the typical payback time is less than one year, with savings averaging between 30 – 40% of total power consumption.
- When used in place of inlet vanes and two-speed motors, VFDs installed in supply and exhaust fans always generate energy savings. The payback time is less than one year
- In theory, installing a VFD on a centrifugal compressor can reduce power consumption by as much as 25%. This very much depends on the control strategy of the chiller plant. The investment cost for a chiller upgrade is relatively high, with a payback time of between 2 – 2.5 years.

09 Main components in an Air Handling Unit

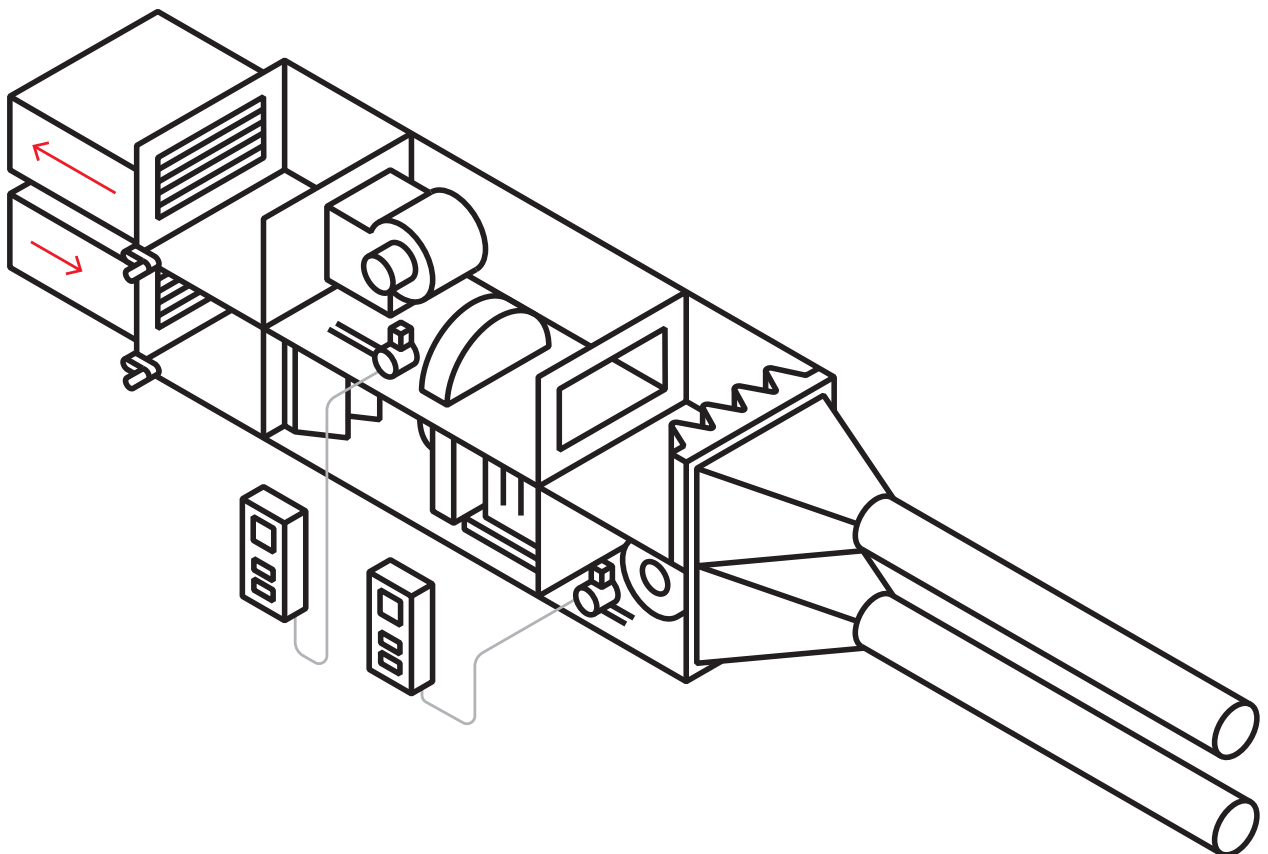



---

**ABB Marine & Ports**

ABB Ability™ Collaborative Operations 24/7

[support.marine@abb.com](mailto:support.marine@abb.com)

+47 91 61 7373

[abb.com/marine](http://abb.com/marine)