

# RPM III IEC Integral HP DC Motors

Rating Guide

IEC 112-280 Frame Sizes

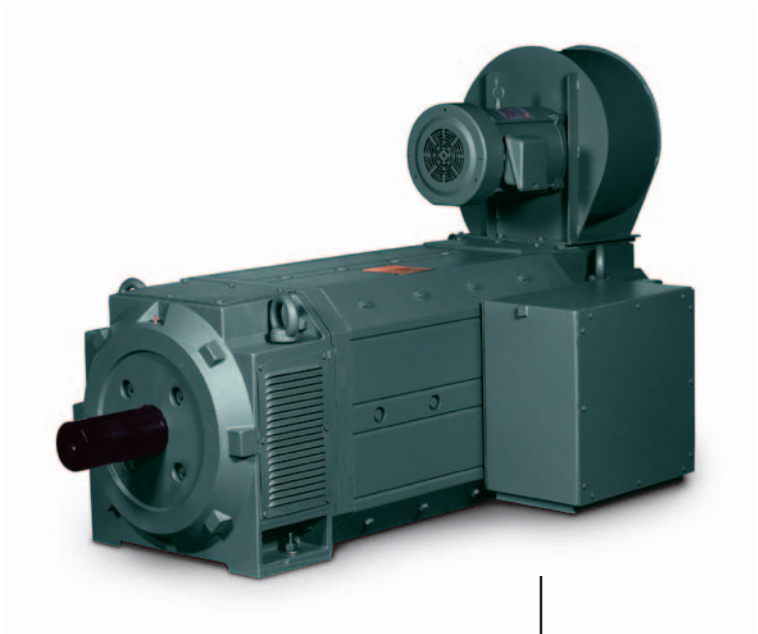

**BALDOR**<sup>®</sup>

A MEMBER OF THE ABB GROUP

## **Mission Statement**

---

*To be the best (as determined by our customers)  
marketers, designers and manufacturers  
of industrial electric motors,  
mechanical power transmission products,  
drives and generators.*

# **IEC Variable Speed Industrial DC Motors Table of Contents**

## **DC Motors – RPM III**

### **General Information**

Introduction ..... 2

### **Motor Features**

General Features ..... 3

Standard Motor Features..... 4

Technical Description of IEC RPM III DC Motors ..... 8

Rating Sheets / Derate Curves ..... 19

Dimension Sheets ..... 88

### **Modifications**

Modifications ..... 120

## **Introduction IEC DC Motors**

### **GENERAL TECHNICAL DATA**

Ratings:	3.7 – 400 kW
Armature voltage:	Up to 600 V
Field voltage:	180/310 V
Insulation class:	H
Ambient temperature:	40°C Maximum
Speed:	Up to 5000 rpm
Balancing:	to DIN ISC 2373
Standards:	IEC and NEMA
Degree of Protection, Method of Cooling	IP23–IC17, IP23-IC06 IP44–IC37 IP44–IC410

### **TYPICAL APPLICATION AREAS**

#### **Metals Industry**

Mill drives, slitting line, tube mills, coating lines, press feeder drives

#### **Textile Industry**

Spinning, elongation, impregnation, winding and cutting

#### **Forest Products Industry**

Pulp preparation, super calenders, winders, rewinders, paper cutters

#### **Printing Industry**

Rotogravure, offset and letter printing presses

#### **Rubber and Chemical Industry**

Extruders, calenders, mixers, centrifuges

#### **Machine Tool Industry**

Spindle drives and positioning drives

#### **General Industry**

Air Conditioning, fans, pumps, conveyors

#### **Material Handling**

Conveyors, transfer lines

## General Features

Baldor•Reliance integral HP DC motors are based on more than 90 years of Baldor•Reliance motor technology that includes the Super T and the original RPM motor – the first DC motor specifically designed to operate from solid-state rectified power. Built to take on industry’s toughest jobs, RPM III motors have proven themselves through on-the-job performance. Whatever your DC requirements, Baldor•Reliance DC motors are the best investment for your motor dollars to give you dependable DC motor performance for years to come.

### UNIQUE LAMINATED SQUARE FRAME FOR BETTER PERFORMANCE

Better performance begins with RPM III motors’ unique laminated square frame. The square configuration packs up to 20% more active material into the same space as a round frame of equivalent shaft height. This permits the Reliance motor to use a larger armature for optimum power generation, and also provides more ventilation area for better heat dissipation. You get more efficient space utilization without compromise in performance or motor life.

The RPM III frames are built from insulated steel laminations, which present an electrical barrier to the formation of eddy currents induced by the static power supply. Compared to cast iron or rolled steel frames, the laminated frame greatly improves commutation for optimum performance and significantly reduces heating for longer life.

Frame rigidity and strength equivalent to solid rolled steel construction are assured by special assembly techniques to maintain minimum 200 psi interlaminar pressure.

### ARMATURE AND FIELD WINDINGS DESIGNED AND TESTED TO INSURE TROUBLE-FREE OPERATION

RPM III armatures are designed for superior commutation through the speed range to insure trouble-free operation. The commutator is a dimensionally stable, homogeneous unit that is easily serviceable. High or low bars are eliminated for better commutation.

Field coils are layer wound to eliminate air pockets which cause performance-limiting hot spots. Field poles bolt securely to the frame to assure axial alignment and uniform air gap between the poles and armature. This assures correct thermal and magnetic conduction for optimum motor performance.

RPM III insulation systems provide an extra margin of safety for those tough industrial applications with Class H materials and process techniques for optimum thermal, electrical and mechanical strength.

### EXCLUSIVE PLS®/POSITIVE LUBRICATION SYSTEM FOR LONGER LIFE

Longer life starts with the patented PLS/Positive Lubrication System. This system, developed and tested by Baldor Electric engineers, provides positive motor bearing protection in any mounting position or operating environment.

The grease directing passage (1) assures that incoming grease is uniformly distributed to both sides of the bearing and to both inboard and outboard grease cavities. These cavities (2&3) are generously sized to allow, in normal applications, one year operation before regreasing is necessary. Grease relief is provided through a drain (4) or along the outboard shaft (5).

Open bearing design allows the lubricant to remove heat from the bearing; inner and outer grease cavities protect the bearings from contamination; close internal clearances (6) and inner anti-churning vanes (7) prevent grease leakage into the motor.

This exclusive lubrication system design results in excellent bearing protection and cooler bearing operation, which contribute to long, trouble-free service regardless of motor application.

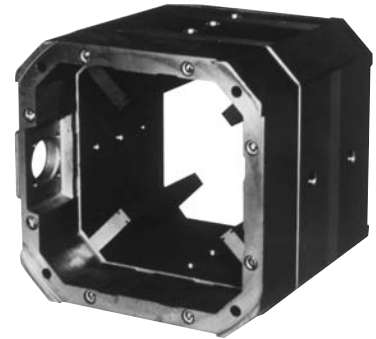

**RPM III laminated frame with integral lead outlet. Typical of frames GK112 through GK280.**

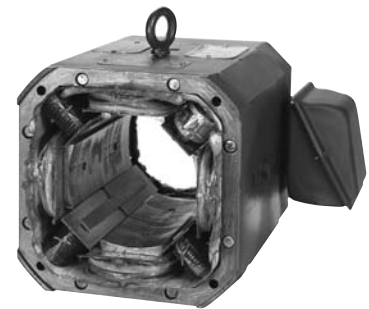

**RPM III wound frame with Class H insulating materials.**



**Inner and outer caps with PLS lubrication system features assure positive lubrication of RPM III motor bearings.**

## Standard Motor Features



**IP23 enclosure with IC06 cooling and optional filter**

This catalog is designed to help motor users quickly select and specify the proper Baldor•Reliance Industrial Direct-Current Motor. Frame size information on standard motors is given on the Frame Size pages. A complete listing and definition of standard motor features is contained in this section. Application requirements beyond the limits of the basic motor will require a modification adder. Modifications are listed immediately following the Dimension Sheets section. The Dimension Sheet and Performance Data Sections contain detailed information required to select and apply DC motors.

The following features and operating conditions apply to standard basic integral horsepower motors in frames GK1104 through GK2810. Additional features or more stringent operating conditions require a modification adder from the Modification Section.

### ENCLOSURES

The Standard Ratings section contains a listing of the following enclosures and methods of cooling for motors cooled with customer supplied air:

IP23-IC17 (Separately Ventilated with Pipe-In Air)

IP44-IC37 (Separately Ventilated with Pipe-In Pipe-Out Air)

To obtain a motor with method of cooling IC06 (Force Ventilation with motor mounted blower), add Mod. 130 – Blower without filter to the above basic motor. Mod. 131 – Filter addition may be added for a motor operating in areas with filterable contaminants.

The Standard Ratings section lists additional enclosures and methods of cooling for motors operating in severe environments:

IP44-IC 410 (Totally Enclosed Non-Ventilated (TENV))

### ALTITUDE

Sea Level to 1000 meters – Standard temperature rise is certified on the basis that the motor will operate at an altitude from sea level to 1000 meters to a maximum ambient of 40°C. IEC 34-1. Motors operating in higher altitudes must have a modification added.

### AMBIENT

Motors as listed are designed so that the temperature rise produced in the motor, added to the standard 40° ambient temperature will not exceed the rated temperature limit of the given insulation system.

Standard motors will provide rated output when operated in an ambient from 0° to 40°C. Operation below 0°C may require a motor with special brushes, grease, shaft material and/or commutator construction.

Motors operating in higher ambient temperatures must have a modification added from the Modification section.

### BALANCE

Standard – Baldor•Reliance DC motors meet the dynamic balance limits of the vibration grade N according to ISO273.

Motors required to meet vibration grade R or S must have a modification added from the Modification section.

### BASE SPEED VARIATION

The base speed for the standard motor shall be within the following tolerance per IEC 34-1 when operated at rated full field with rated load and voltage with

## Standard Motor Features

the windings at working temperature. (Note that the variation in speed can be above and below rated speed.)

kW per 1000 r/min	Base Speed Tolerance
Not less than 2.5 but below 10	± 7.5%
10 and upwards	± 5%

### BEARINGS

Standard IEC DC motors utilize ball bearings. These bearings and their internal clearances have been especially selected based on load carrying ability, thermal stresses and speed range consistent with ample bearing life. Roller bearings are used for belted duty on frames UGK180-UGK280 per the Modification section. The “U” prefix indicates roller bearing for belted duty.

The patented Baldor•Reliance PLS/Positive Lubrication System, with deep grooved, anti-friction ball bearings, gives complete bearing protection and long bearing life.

### ARMATURE CHOKE -SEPARATE FROM MOTOR

For good commutation, Baldor•Reliance RPM III IEC DC motors normally do not require any armature choke. Where the motors are operated from static converters, higher natural residual harmonic is produced, especially in the lower speed range, which can cause vibrations. On a few drive applications, these vibrations can be disturbing. Through an additional armature choke, the armature current is smoothed, resulting in smoother motor operation. Refer to Application Engineer – Baldor Electric Company.

### TERMINAL BOX

Standard construction for frames GK132 through GK280 provides an IEC terminal box which can be located in any quadrant as long as no accessories such as blowers are in that same quadrant.

### CONNECTIONS

Standard motor leads are terminated in the terminal box to terminal strip.

### DIRECTION OF ROTATION

Unless otherwise ordered, brush rigging is assembled for standard direction of rotation, counter-clockwise for motors and clockwise for generators facing the commutator end. Baldor•Reliance DC motors will operate in either direction of rotation without changing the angle of the brush holders for normal field weakened speed ranges.

### FINISH-PAINT

Standard finish is Baldor Electric blue (RAL5010) modified epoxy, air dry enamel with non-toxic rust inhibitors.

### INSULATION

The standard RPM III insulation system is rated for Class H rise. It is a thoroughly tested and proven system providing excellent protection against the effects of mild chemical and high humidity. The armature and field coil insulation systems were evaluated for thermal life based on “DC Motorette” test. Insulation materials used in this system include: Nomex ground insulation, polyester film coated high temperature moisture resistant magnet wire, resin saturated woven glass sleeving, glass tape, high strength glass, reinforced resin filled top wedges and coil retainers and coating with high temperature (180°C) varnish.

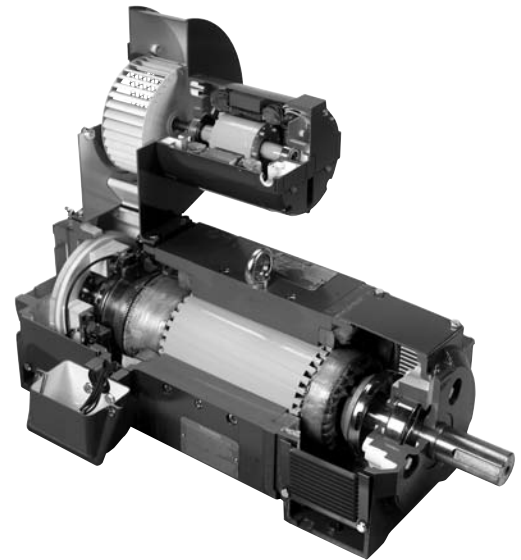

RPM III construction typical of frames IEC GK132 through GK280



Armature assembly with Class H (180°C) insulation system

## Standard Motor Features



Typical Integral foot construction of RPM III motors.

### LUBRICATION

IEC RPM III DC motors have the Patented PLS/Positive Lubrication System developed and tested by Baldor Electric to provide positive motor bearing protection. Open bearing design allows the lubricant to remove heat from the bearing.

Standard grease may be used in ambients down to  $-25^{\circ}\text{C}$ .

### MOUNTING

Foot and flange mounting in accordance with IEC standards.

Motors will operate successfully mounted on the floor, wall or ceiling and with the shaft at any angle from horizontal to vertical. Hand-hole covers can be interchanged as necessary on the commutator-end bracket eliminating the need for bracket rotation when wall mounted.

### OVERLOAD

Momentary Overloads – Standard DC motors shall be capable of operating with successful commutation for a period of one minute with a current load of 150 percent of the base speed full-load current at all speeds within the rated speed range. Refer to the Application Data Section for additional information on overloads.

### POWER SUPPLY

Standard IEC RPM III motors are specifically designed to operate on rectified power supplies.

### SERVICE FACTOR

Standard RPM III motors have a 1.0 service factor rating. Service factor is defined as a multiplier which when applied to the rated kW, indicates a permissible kW loading which may be carried without harm to the motor.

### SHAFT EXTENSION AND METHOD OF DRIVE

IEC RPM III frames GK112 through GK160 are supplied with a drive end shaft suitable for either coupled or belted drive application. Radial load must not exceed the values listed in the Technical Description section.

Frames GK180 through GK280 are supplied with short shaft extensions that can be used for coupled drives only. A modification must be made for frames with roller bearing for belted drives.

### MAXIMUM SAFE SPEED (MSS)

Refer to Technical Description for maximum permissible operating speed. These speeds must not be exceeded under any condition. Motor control must hold the maximum speed under any load condition including no-load within the maximum safe speed. Drive systems whose design characteristics inherently prevent the DC motor from exceeding the Motor Maximum Safe Operating Speed must prevent the motor from exceeding the Maximum Safe Speed if a single component failure should occur.

### **⚠ A WARNING**

**THE MACHINERY BUILDER IS RESPONSIBLE FOR INSURING THAT DRIVEN MACHINERY AND ALL DRIVE TRAIN MECHANISMS NOT SUPPLIED BY BALDOR ELECTRIC AND PROCESS LINE MATERIAL ARE CAPABLE OF SAFE OPERATION AT THE MAXIMUM SPEEDS, AS SHOWN IN TABLE ON PAGE 11. FAILURE TO DO SO CAN RESULT IN DESTRUCTION OF MECHANISM OR MATERIAL AND FLYING FRAGMENTS, ENDANGERING OPERATING PERSONNEL.**



## Standard Motor Features

### TACHOMETER MOUNTING

IEC RPM III frames GK132 through GK250 have as a standard feature a provision for mounting an integral AC or DC tachometer.

### TEST-STANDARD

Each motor is given a routine test to determine that it is free from electrical or mechanical defects and to provide assurance that it meets design specifications. This test consists of:

(Test data is not supplied to customer without additional charges.)

Neutral check

Winding resistance

Commutation check

High potential test

No-load test at base speed and maximum field weakened speed

Full-load test at base speed and maximum field weakened speed

### VOLTAGE

Armature and shunt field voltages are indicated on the Rating Sheet and Performance Curve pages.

### MODIFICATIONS:

#### Versatile Pre-engineered Modifications

A complete line of modifications are available for production motors to meet special application requirements. The Modification Section of this catalog includes a description on these additions to standard motors.

### FRAME DESIGNATIONS

Frame diameters indicate the shaft height in millimeters; that is, 112, 132, 160, 180, 200, 225, 250, and 280. The first two numbers on the frame designation refer to the frame diameter and the second two numbers are a code for the core length.

#### Prefixes:

Prefix "GK" indicates an IEC DC motor.

Prefix "U" indicates a roller bearing for belted duty.

Prefix "L" indicates a longer commutator and commutator end bracket.

#### Suffixes:

Suffix "Z" indicates a foot mounted motor with special shaft dimensions.

Suffix "Y" indicates a flange mounted motor.

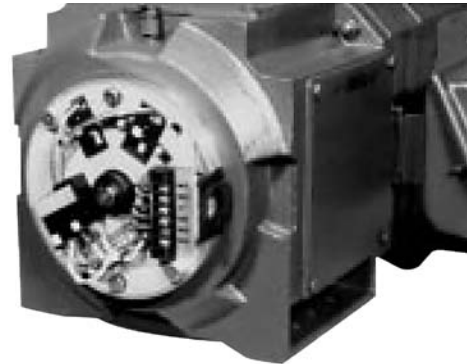

Integral RD-120 digital tachometer with cover removed. Frames GK1303-GK2510

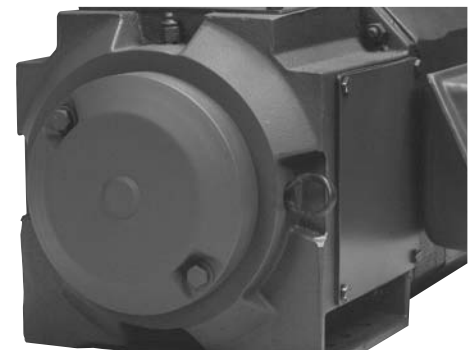

Integral DC or digital tachometer adds only 1.56 inches to motor length. Frames GK1303 - GK2510.

**CAUTION:** Protective cover to guard against contact with rotating shaft must be in place when tachometer is not mounted.



Accessory Face for mounting tachometer. Typical construction for Frame GK280.

## Table of Contents

### Technical Description

ACCEPTANCE, SUPERVISION OF MANUFACTURE .....	10	MAXIMUM SAFE SPEED .....	11
AIR SUPPLY .....	14	METHODS OF COOLING PER IEC 34-6 .....	13
ALTITUDE .....	10	MOTOR PROTECTION DEVICES .....	17
AMBIENT TEMPERATURES .....	10	MOTORS WITH FORCE VENTILATION – IC06 – MOD. 130. ....	14
APPLICATION .....	9	MOUNTING .....	12
AXIAL THRUST CAPACITY IN KILOGRAMS		NOISE LEVEL .....	17
FOR MINIMUM B-10 BEARING LIFE .....	15	OVERSPEED SWITCH/DC TACHO GENERATOR COMBINATION .....	18
BALDOR DESIGN .....	9	PAINTING, CORROSION PROTECTION .....	17
BEARING ARRANGEMENT FOR BELTED DUTY .....	15	PRESSURE SWITCH .....	18
BEARING ARRANGEMENT FOR STANDARD DESIGN .....	15	RADIAL LOAD CAPACITY .....	15
BEARINGS .....	14	RATING .....	10
BLOWER MOTOR RATING FOR MOTOR MOUNTED BLOWERS		SELF-VENTILATED DC MOTORS, METHOD OF COOLING IC01 .....	10
ON FORCE-VENTILATED MOTORS .....	14	SHAFT END .....	16
BRAKES -DISC TYPE .....	18	SLIDE RAILS .....	18
BRUSH WEAR PROTECTION .....	17	SPACE HEATER .....	18
CONSTANT TORQUE CAPABILITIES – FRAMES GK1104-GK2810 ...	10	SPECIAL BALANCING ACCORDING ISO 2373 .....	16
COUPLINGS .....	16	STANDARD MOTOR FEATURES – SUMMARY .....	10
CROSS REFERENCE BETWEEN IEC AND NEMA NOMENCLATURE ..	13	STANDARDS, SPECIFICATION .....	10
DC MOTOR PRODUCT LINE .....	9	TACHOMETER GENERATORS AND PULSE GENERATORS .....	18
DEGREE OF PROTECTION PER IEC 34-5 .....	13	THERMISTORS .....	17
DESIGN FOR GEARBOX FLANGE ATTACHMENT .....	16	THERMOSTATS .....	17
DIRECTION OF ROTATION .....	11	TRIPPING DEVICE RELAY .....	17
FILTER ATTACHMENT FOR MOTOR MOUNTED BLOWER –		VALIDITY .....	9
MOD. 131. ....	14	VIBRATION PROVED DESIGN .....	17
FLANGE CONCENTRICITY AND SHAFT RUN OUT .....	17	WARNING/HIGH LIMIT .....	17
INSTRUCTION MANUAL .....	18	ZERO-SPEED OPERATION .....	11

## Technical Description

### VALIDITY

The technical description applies for Frames sizes IEC GK1104-GK2810 of RPM III DC motors.

### APPLICATION

Direct current motors are suitable for all types of drives, with or without speed control.

Industry applications are:

- Converting
- Conveying technology
- Graphic arts industry
- Machine tool industry
- Metals industry
- Paper manufacturing
- Plastics processing industry
- Ship construction
- Textile machinery industry
- Tire/Rubber industry
- General industry applications

### BALDOR DESIGN

For over 100 years, Baldor Electric has been manufacturing electrical machinery and introduced the first fully laminated industrial direct current motor with square laminated cross-section 40 years ago, which has been continuously improved. The new RPM III DC motors are based on these proven motors and are additionally designed according to the latest technological developments. The exceptional characteristics of this direct current motor design are:

- High output rating per frame size
- Compact design by square laminated frame
- Easy operation on static converter power supply
- Suitable for high current increase rates due to fully laminated magnetic circuit
- Good commutation on static converter power supply
- Extended operation reliability due to class “H” insulation system
- Integral foot construction of rigid vibration-resistant mechanical assembly and maximum bearing support
- Low noise operation and smooth performance provided by rabbet fit frame to bracket and integral foot construction
- Faster response and shorter cycle times by low inertia design
- Suitable for belt drive due to high admissible transverse forces
- Reliance patented PLS – Positive Lubrication System for bearings
- Adequately dimensioned terminal boxes with easy access for customer cable connections
- Position of terminal box changeable (even on site) to customers requirements
- Large hand hole openings and rotatable brush rigging for easy access to all brushes
- Adaptable modular system for all types of design, protection and cooling
- Extensive standard program of additional modifications.

### DC MOTOR PRODUCT LINE

#### INTERNALLY VENTILATED MOTORS

	<b>GK1104-GK2810</b>	<b>GK1104-GK2810</b>	<b>GK1104-GK2810</b>
Degree of Protection	IP23	IP44	IP23
Method of Cooling	IC17	IC37	IC06
Output-kW	3.7-404	3.7-404	3.7-404

#### TOTALLY-ENCLOSED MOTORS

	<b>GK1104-GK1610</b>
Degree of Protection	IP44
Method of Cooling	IC410
Output-kW	2-16

## Technical Description

### STANDARD MOTOR FEATURES – SUMMARY

Refer to GENERAL INFORMATION – page 2 for complete features.

All machine components such as frame, end plates, bearing caps, shaft, terminal box, etc., are machined on the latest CNC machine tools. This ensures a uniformly high quality standard with very low production tolerances. The motor feet are integral, which results in a rigid, vibration-resistant design. Mainpoles are bolted securely to the frame. Interpoles are integrated in the frame lamination for frame size GK112 to GK280.

The shaft is designed for flexible coupling or for belt drive operation.

On frame sizes GK132 to GK280, the position of the terminal box can be changed on site to any required position, simply by turning the frame. The terminal box can also be rotated to 4 x 90° positions.

All motors are designed according to the modular principle, and are thus simple to modify. The attachment of external ventilation, filter, pipe connection, tachogenerator attachments etc. is possible.

In the standard design, the motors are equipped with a straight shunt excitation winding for external excitation. A stabilizing shunt winding (series field winding) can also be fitted, if necessary.

### RATING

The nominal output rating shown in the selection tables is based on the following conditions.

- Continuous operation -S1
- Ambient temperature -40°C maximum
- Installation altitude -up to 1000 m above sea level
- Insulation material -Class "H"
- Standards -IEC and NEMA
- Motor supplied by fully controlled three-phase current bridge or direct current generator or battery
- Rated armature and field voltages are specified on rating sheet
- Enclosures with IEC protection and method of cooling as specified on the Standard Ratings page. The following IEC ratings are specified.

### Basic Ratings

- IP23 IC17 -Separately Ventilated with Pipe-In air
- IP44 IC37 -Separately Ventilated with Pipe-In Pipe-Out Air
- IP44 IC410 -Totally Enclosed Non-Ventilated (TENV)

Available with modification addition – IP23 IC06 – Motor cooled by motor mounted blower (Refer to Mod. Section)

### ALTITUDE

Standard guarantees are made on the basis that the motor will operate at an altitude from sea level to 1000 m per IEC 34-1. Refer to Mod. 101 for motors operating at higher altitudes.

### AMBIENT TEMPERATURES

Motors are designed so that the temperature rise produced in the motors, added to the standard 40°C ambient temperature will not exceed the rated temperature limit of the insulation system. Standard motors will provide rated output when operated in an ambient from 0 to 40°C. Operation below 0°C may require a motor with special brushes, grease, shaft material and/or commutation construction. Refer to Mod. 105 for motors suitable for operation in higher ambients.

### STANDARDS, SPECIFICATION

The direct current motors comply with IEC Publication 34.

The shaft heights and other mounting dimensions are designed in accordance with IEC 72.

### ACCEPTANCE, SUPERVISION OF MANUFACTURE

Direct current machines according to the Rules of the Classification Societies, are normally accepted by a representative of the Classification Societies.

The acceptance and possible supervision of manufacture is carried out in our Gainesville plant.

The fees of the Classification Societies for acceptance and supervision of manufacturing will be separately charged according to the costs incurred.

### SELF-VENTILATED DC MOTORS, METHOD OF COOLING IC01

Self-ventilated motors have a considerable smaller amount of cooling-air volume at reduced motor speeds. Therefore for rating and frame size of self-ventilated DC motor please contact the Application Engineer – Baldor Electric Company.

### CONSTANT TORQUE CAPABILITIES – FRAMES GK1104-GK2810

Motor mounted blowers or separate force ventilation for motors permit continuous full torque operation from base speed down to approximately one percent of base speed when the blower motors are operated on 50/60 Hz power.

## Technical Description

### MAXIMUM SAFE SPEED

DC motors are inherently capable of reaching speeds hazardous to personnel and equipment if improperly connected or misapplied. Operation of a shunt wound or compound wound motor without the shunt field energized at the proper current may cause the motor to reach a dangerous speed. Both the motor instruction manual and the control instruction manual must be followed when the motor is being connected and operated and the work must be performed by qualified personnel.

Protective devices such as overspeed switches, field loss relay or tachometers must be used in the control circuit to limit motor speeds to the values given in the following table unless the motor speed is limited by the application.

The speeds are the maximum mechanically safe operating speeds for frames with standard construction. These speeds must not be exceeded under any condition. Motor control must hold the maximum speed under any load condition including no-load within the maximum safe speed. Drive systems whose design characteristics inherently prevent the DC motor from exceeding the Motor Maximum Safe Operating Speed must prevent the motor from exceeding the Maximum Safe Speed if a single component failure should occur.

Type	Maximum Safe Speed RPM
GK1104-GK1108	5000
GK1110-GK1311	4500
GK1606	4500
GK1608	4500
GK1610	3400
GK1808	4000
GK1810	3400
GK2008	3600
GK2010	3400
GK2208	3200
GK2210	2875
GK2508	3000
GK2510	2350
GK2808	3000
GK2810	2450

### **⚠ WARNING**

**THE MACHINERY BUILDER IS RESPONSIBLE FOR INSURING THAT DRIVEN MACHINERY AND ALL DRIVE TRAIN MECHANISMS NOT SUPPLIED BY BALDOR ELECTRIC AND PROCESS LINE MATERIAL ARE CAPABLE OF SAFE OPERATION AT THE MAXIMUM SPEEDS, AS SHOWN IN ABOVE TABLE. FAILURE TO DO SO CAN RESULT IN DESTRUCTION OF MECHANISM OR MATERIAL AND FLYING FRAGMENTS, ENDANGERING OPERATING PERSONNEL.**

### DIRECTION OF ROTATION

All DC motors of the RPM III series are bidirectional, and equally suited for both directions of rotation.

For force-ventilation with motor mounted blower, the specified direction of rotation of the blower, marked by an arrow, must be observed, to get the correct amount of cooling air.

### ZERO-SPEED OPERATION

The permissible operating time at zero speed (armature at standstill) with various percent rated armature currents is as follows. **Motor must have cooling air provided either by separate ventilation or by motor mounted blower.**

Rated Armature Current %	Permissible Time for Zero Speed Operation with Cooling Air to Motor
100	10 seconds
55	30 seconds
35	1,5 minutes
15	Continuously

**The above values must not be exceeded during the adjustment of armature current limitation under locked armature condition and all other operating conditions.**

## Technical Description

### MOUNTING

Mountings are according to DIN 42 950 or IEC 34 – Standard construction is IMB3.

Contact Application Engineer – Baldor Electric Company for availability. Refer to Mod. 140 for IM B35 (83/85) and IM V1.

The most common mountings are shown in the table below:

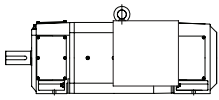
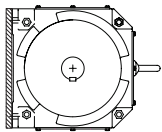
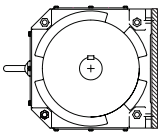
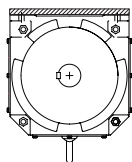
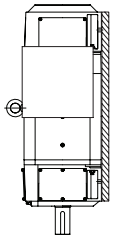
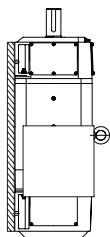
Constructions acc. to			
DIN 42950	Design	IEC-Code I 34-7	IEC Code II
B3		IM B3	IM 1001
B6 ②		IM B6	IM 1051
B7 ②		IM B7	IM 1061
B8 ②		IM B8	IM 1071
V5 ②		IM V5	IM 1011
V6 ②		IM V6	IM 1031

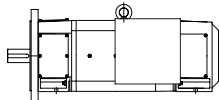
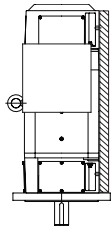
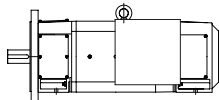
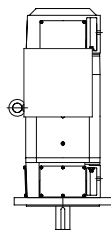
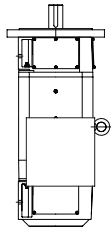
Constructions acc. to			
DIN 42950	Design	IEC-Code I 34-7	IEC Code II
B3/B5		IM B35	IM 2001
V1/V5 ②		IM V15	IM 2011
B5 ①		IM B5 ①	IM 3001
V1		IM V1	IM 3011
V3		IM V3	IM 3031

① Motor construction IM B5 generally designed as IM B35.

② Mechanical support required.

## Technical Description

### DEGREE OF PROTECTION PER IEC 34-5

Degree of protection for the motor consists of the letters IP (International Protection) followed by two characteristic numerals indicating the amount of protection offered by the motor enclosure. The first number indicates the degree of protection provided by the enclosure with respect to persons and objects. The second number indicates the degree of protection provided by the enclosure with respect to harmful effect due to ingress of water.

Designations for various degrees of protection for IEC DC motors are as follows:

- IP23 Motor is protected against ingress of solid objects greater than 12 mm and against dripping water when the machine is tilted at any angle up to 15° from its normal position. Motors with this protection may be priced from the basic price pages.
- IP44 Motor is protected against ingress of solid objects greater than 1 mm and against water, splashing against the machine from any direction. Motors with this protection may be priced from the basic price pages.
- IP54 Motor is protected against entrance of dust in sufficient quantity to interfere with satisfactory operation of the machine and against water splashing against the machine from any direction. Price motors with this degree of protection by pricing frames with IP44 protection and add Mod. 183A Dust-tight Features.
- IP55 The entry of dust is not totally prevented, but dust cannot enter in sufficient quantity to interfere with satisfactory operation of the motor. Projection of water by nozzle from any direction has no harmful effect.

### METHODS OF COOLING PER IEC 34-6

Methods of cooling the motor are designated by the letter "IC" (International Cooling) followed by numerals and letters representing the circuit arrangement, the coolant and the method of movement of the coolant. The first number defines the cooling circuit arrangement. The second number defines the method of movement of the primary coolant (air). The letter for the coolant may be omitted when the coolant is air.

Designations for various methods of cooling IEC DC motors are as follows:

- IC01 Cooling air is drawn directly from the ambient surrounding the motor and is discharged out. Air is moved by an internal fan mounted on the motor shaft making the amount of cooling air dependent on motor speed. Motors with this method of cooling are not contained in this catalog but may be available from Baldor Electric Company – Application Engineer.
- IC06 Cooling air is drawn directly from the ambient surrounding the motor but is circulated through the motor by means of a blower driven by a constant speed AC motor making the amount of cooling air independent of DC motor speed. Motors with this method of cooling may be obtained by adding Mod. 130 – Blower without Filter – to the Basic motors – IP23 IC17 IC37.

- IC17 Cooling air is provided by a customer supplied source piped into the motor, circulated through the motor and discharged to the ambient surrounding the motor. The cooling air inlet is on the non-drive end (commutator end) and the outlet air leaves the motor via the louvers on the drive side. Motors with this method of cooling are listed on the Standard Ratings pages – IP23 IC17 IC37.
- IC37 Cooling air is provided by a customer supplied source piped into the motor, circulated through the motor and piped out of the motor to an area remote from the motor. Motors with this method of cooling are listed on the Standard Ratings pages – IP23 IC17 IC37.
- IC410 Air inside the motor is circulated by an internal fan. Heat is conducted through the frame of the motor to the surrounding ambient air. Motors are listed on the Standard Ratings pages – IP44 IC410.
- IC411 Air inside the motor is circulated by an internal fan. Heat is conducted through the frame of the motor and removed by a fan connected to the motor shaft. Motor cooling is dependent on motor speed. Motor is identified as IP44 IC411. Motors with this type of cooling are not contained in this catalog.
- IC416 Air inside the motor is circulated by an internal fan. Heat is conducted through the frame of the motor and removed by a fan driven by a separately powered AC motor. Motor cooling is independent of DC motor speed. Motors with this type of cooling are not contained on this catalog.

### CROSS REFERENCE BETWEEN IEC AND NEMA NOMENCLATURE

#### DEGREE OF PROTECTION

IEC	NEMA
IP22	DPG or DPFV
IP23	Splashproof
IP44	TENV, TEFC or TEAO
IP54	Dust-Tight Features

#### METHOD OF COOLING

IEC	NEMA
IC01	DPG
IC06	DPFV
IC17	DPSV (Drip-proof Separate Ventilated)
IC37	PIPO(Pipe-In Pipe-Out, Totally-Enclosed Pipe Ventilated, Totally Enclosed Separately Ventilated)
IC410	TENV
IC411	TEFC
IC416	TEAO-Inline or Piggyback
IC616	A/A-Totally Enclosed Dual Cooled with Air-to-Air Heat Exchanger

## Technical Description

### AIR SUPPLY

Cooling air through a self-ventilated or forced-ventilated motor must be clean and have relative humidity between 30% and 100% with no free water in the air. Use of damp, cool outside air with high humidity and free water may cause the motor to flash over. Use of excessively dry air may cause excessive brush and commutator wear. Cooling air temperature must not exceed the maximum ambient temperature indicated on the motor nameplate (standard 40°C). Cooling air temperature must not be lower than 0°C to provide base speed and regulation within limits. Use of outside air below 0°C may cause excessive brush and commutator wear due to the low humidity. Cooling air absolute humidity must be at least 71 grains per cubic meter.

Separately ventilated motors must have the following volume of air to adequately cool the motor unless the motor nameplate specifies a different value.

**NOTE:** Motors located in damp, moist environments must have space heaters or fields energized at 50% voltage to protect against condensation when the motor is not operating.

Frame	Speed RPM	Air Volume M <sup>3</sup> /min.	Static Pressure mm-Water
GK1104-GK1110	All	4.3	50.8
GK1303-07	All	8.4	57.2
GK1309-11	All	8.4	104.1
GK1606	All	12	50.8
GK1608-10	All	11	86.4
GK1808	All	15	95.3
GK1810	All	15	95.3
GK2008	All	20	101.6
GK2010	All	20	101.6
GK2208	All	27	129.5
GK2210	All	27	129.5
GK2508-10	All	34	101.6
GK2806-10	All	55.5	190.5

### MOTORS WITH FORCE VENTILATION – IC06 – MOD. 130.

Standard Ratings are for separately force ventilated motors with customer supplied air – IC17 and IC37. Refer to Mod. 130 for the addition of a motor mounted blower to force ventilate the motor with ambient air – IC06. The blower is mounted on top or to one side at the non-drive end bracket.

Protective device, e.g. thermistors, thermostats and/or air pressure switch, are recommended in the event of cooling air loss on either separately ventilated motors or force ventilated motors.

The attached external blower is driven by a 3-phase AC motor. The standard external blower motors are designed with a winding for 380-420V, 3-phase, 50 Hz. The nominal current required is stated in the following table.

### BLOWER MOTOR RATING FOR MOTOR MOUNTED BLOWERS ON FORCE-VENTILATED MOTORS

Frame	Hp <sup>(1)</sup>	Amps <sup>(1)</sup>
GK1104-GK1110	.75	1.2
GK1303-07	.75	1.2
GK1309-11	.75	1.2
GK1606	.75	1.2
GK1608-10	.75	1.2
GK1808-10	1.5	2.6
GK2008-LGK2010	1.5	2.6
GK2208-LGK2210	2.5	3.8
GK2508	2.5	3.8
GK2510	2.5	3.8
GK2806-10	4.2	6.0

(1) Rating for 380, 3-phase, 50 Hz.

### FILTER ATTACHMENT FOR MOTOR MOUNTED BLOWER – MOD. 131.

With inadequate purity of the cooling air, the attachment of a filter is recommended. The filter is fitted for easy replacement. The filter is attached to air inlet of the blower. The rated output of the DC motor is not affected by the filter (no reduction).

### BEARINGS

The antifriction bearings are designed for a long life time and extended relubrication periods. They ensure low noise and low vibration operation. Standard DC motors utilize ball bearings. These bearings and their internal clearances have been especially selected based on load carrying ability, thermal stresses and speed range consistent with ample bearing life. Roller bearings are used on belted duty frames UGK180 through UGK280. Refer to Mod. 126.

All motors have the proven and patented BALDOR-PLS SYSTEM (Positive Lubrication System). This system ensures safe and reliable lubrication of the antifriction bearings.



## Technical Description

### BEARING ARRANGEMENT FOR STANDARD DESIGN

Especially suitable for elastic coupling operation.

Antifriction Bearing Type Frame Size	Drive End	Non-drive End
GK112	C208	C206
GK132	C310	C209
GK160	C313	C210
GK180	C215	C211
GK200	C217	C213
GK225	C219	C216
GK250	C219	C219
GK280	6222	6219

### BEARING ARRANGEMENT FOR BELTED DUTY

Refer to Mod. 126.

Especially suitable for belt or gear drive operation.

Frame Size	Anti-friction Bearing Type	
	Drive End	Non-drive End
GK112	C208	C206
GK132	C310	C209
GK160	C313	C210
UGK180	NU215	C211
UGK200	NU217	C213
UGK225	NU219	C216
UGK250	NU222	C219
UGK280	NU222	6219

### AXIAL THRUST CAPACITY IN KILOGRAMS FOR MINIMUM B-10 BEARING LIFE OF 10,000 HRS. WITH NO EXTERNAL OVERHUNG LOAD

Frame GK	AXIAL THRUST CAPACITY KILOGRAMS							
	Horizontal Mounting				Vertical Mounting <sup>(1)</sup>			
	2500 rpm	1750 rpm	1150 rpm	850 rpm	2500 rpm	1750 rpm	1150 rpm	850 rpm
1104-10	134	156	189	216	139±20	161±20	195±20	223±20
1303-11	231	256	290	318	243±62	268±62	302±62	329±62
1606-10	243	270	306	329	263±116	290	327	349
1808-10	295	329	374	404	324±163	361	404±163	451
2008-10	383	426	483	522	417±203	463	524	561±203
2208-10	474	526	596	644	526±300	581±300	655	705
2508	612	739	907	1021	653±297	826±297	1002±297	1123±297
2510	594	717	896	998	622±374	821±374	998±374	1116±374
L2510	580	703	871	987	658±424	812±424	991±424	1111±424
GK2808 GK2810	612	748	908	1,021	714±374	828±374	986±374	1123±374

(1) Thrust capacity for vertical mounting includes a constant whose value is plus or minus depending on the direction of the thrust load. The constant is plus for thrust loads acting upward against the force of gravity and minus for loads acting downward with gravity.

### RADIAL LOAD CAPACITY

Frame	Radial Load Capacities at the End of the Shaft - Kilograms <sup>(2)</sup>			
	2500 rpm	1750 rpm	1150 rpm	850 rpm
1104-10	227	256	284	
1303-11	488	570	510	510
1606-10	726	794	896	941
<sup>(1)</sup> 1808-10	1225	1225	1225	1225
<sup>(1)</sup> 2008-10	1361	1361	1361	1361
<sup>(1)</sup> 2208-10	1724	1724	1724	1724
<sup>(1)</sup> 2508-10	2722	2722	2722	2722
<sup>(1)</sup> 280	2313	2631	2631	2631

(1) Data for motors with roller bearings on the drive end.

(2) **CAUTION:** The use of these radial load capacities requires the accurate calculation of the radial load for the application. Radial loads for gears, sprockets, and flywheel are usually accurately determined, but the radial loads due to v-belt drives are subject to miscalculations because they do not include all of the pre-tension load (belt tightening). The calculations of the radial load for a V-belt drive must include the pre-tension for transmitting the horsepower, pre-tension for centrifugal force on the belts, pre-tension for high starting torques, rapid acceleration or deceleration, pre-tension for drives with short arc-of-contact between the V-belt and sheave, and low coefficient of friction between belt and sheave caused by moisture, oil or dust.

## Technical Description

### DESIGN FOR GEARBOX FLANGE ATTACHMENT

Refer to Mod. 244.

Where motors are attached directly to the gearbox flange without an adapting frame, an oil-tight flange design is required.

In addition, the drive side bearing must be protected by a radial shaft lip seal ring (oil seal) to prevent the penetration of lubricants. Refer to Mod. 275. During operation, the shaft lip seal must be moistened or lubricated by occasional oil spray or air containing oil mist. On V3 type motors, where the gearbox oil has continuous contact with the shaft lip seal, the penetration of lubricants into the motor, has to be prevented by a shaft face seal. Refer to Mod. 276.

The continuous operation temperature of the gearbox oil must not exceed 100°C. It has to be checked, whether the higher transverse forces caused by the gearbox pinion require a special drive side bearing.

### SHAFT END

The shaft ends are designed in accordance with DIN 748, with key ways according to DIN 6885, sheet 1. The keys will be supplied with the motor.

The dimensions of the standard shaft ends are shown in the dimension sheet section. Special shaft dimensions per DIN or NEMA or a special non-drive end shaft can be supplied. Refer to Mods. 269-279.

### COUPLINGS

The DC motors can be connected to the driven machine by elastic couplings. Rigid couplings are not permitted for electric motors with antifriction bearings.

The couplings must be drilled, grooved and dynamically balanced.

Where delivery of the motors with coupling is ordered, the driving coupling part will be finish machined and will be supplied mounted on the shaft. The driven coupling part will be supplied pre-bored. Refer to Mods. 177 and 178.

### SPECIAL BALANCING ACCORDING ISO 2373

The rotors are dynamically balanced with inserted key. The mechanical balancing is normally equivalent to vibration grade N according to ISO 2373.

For increased requirements on the mechanical balancing, vibration grade R or S can be achieved by additional measures. Refer to Mods. 112 and 113 for vibration grade R and S.

Limiting values of vibration velocity for vibration grades N, R and S are given in the table.

### LIMITING VALUES OF VIBRATION VELOCITY OF ELECTRICAL MACHINES ACCORDING TO ISO 2373

		Max. r.m.s. values of vibration velocity in mm/sec. Tolerance + 10% v eff in mm/s for frame sizes		
Vibration Grade	Speed RPM	Frame 1104-10 v eff	Frame 1303-2210 v eff	Frame 2508-10 v eff
N (normal)	600-3600	1.8	2.8	4.5
R (reduced)	600-1800	0.71	1.12	1.8
	>1800-3600	1.12	1.8	2.8
S (special)	600-1800	0.45	0.71	1.12
	>1800-3600	0.71	1.12	1.8

Above 3600 rpm the limiting values must be computed linear.

## Technical Description

### NOISE LEVEL

Baldor•Reliance motors have a noise level as stated in the following table:

Motor Type GK	Measuring surfaces-noise level at motor speed 2500 rpm dB(A)
112	75
132	82
160	83
180	83
200	85
225	87
250	88
280	88

Mean Sound Pressure Level, dBA at 1 m, with motor operating at base speed and full load on Power Supply. Levels are nominal value and may vary +3, -7 dBA on specific motors. All data based on the mean value of four microphone positions under free field conditions (R-infinity). Refer to Baldor Electric if guaranteed values are required).

### VIBRATION PROVED DESIGN

Refer to Mod. 440.

If DC motors are exposed to shocks or violent vibrations, this has to be advised in the order specification. In those cases a special design is recommended.

### PAINTING, CORROSION PROTECTION

Generally, the internal motor surfaces are not corrosion protected. The outside motor surfaces are primer coated and finished with a synthetic paint, color RAL 5010 blue. Color RAL 6011 green can be supplied on request without extra charge. Other colors require an additional adder.

The surface protection is appropriate for operation in dry or slightly humid ambient. Improved corrosion protection is recommended in moist and wet ambient as well as for operation in chemical aggressive areas.

### FLANGE CONCENTRICITY AND SHAFT RUN OUT

Flange motors will be delivered normally according DIN 42 948, tolerances class "N" (normal).

For special requirements tolerance class "R" (-reduced) will be available. Refer to Application Engineer – Baldor Electric Company.

### MOTOR PROTECTION DEVICES

#### THERMISTORS

Refer to Mods. 412-416.

Thermistors can be fitted in the motor frame windings to protect the windings against over heating. Due to the different thermal time constants and because the armature windings cannot be

supervised directly, complete winding over temperature protection is not ensured only by thermistors. Therefore the use of overcurrent tripping devices is required additionally.

Thermistors are built into each frame winding (e.g. main coils, intercoils and pole face winding (if existing) at the air outlet side). The functions "warning" and "switch off" are available. Each function normally consist of 3 thermistors.

#### WARNING/HIGH LIMIT

Two sets of the same function are inserted in the stator windings. Each set is connected in series and brought out to the terminal box. When ordering, the required function (warning or high limit) has to be advised.

#### TRIPPING DEVICE RELAY

The tripping device must be supplied as part of the control system in the control panel. The number of tripping devices depends on the required functions (warning and/or high limit). Each function requires a separate tripping device.

#### THERMOSTATS

Refer to Mods. 410-411.

Thermostats can be inserted in the intercoil windings to help protect the windings against over heating. Due to the different thermal time constants and because the armature windings cannot be supervised directly, complete winding over temperature protection is not ensured only by thermostats. Therefore the use of overcurrent tripping devices is required additionally. Thermostats are built into the intercoil windings at the air outlet side. When reaching the tripping temperature, bi-metal contacts are actuated.

#### BRUSH WEAR PROTECTION

Non-potential free – refer to Mod. 155A.

Brush wear sensor provides output from motor when brushes wear to a predetermined length. Signal gives indications of brush wear so that corrective action may be taken to prevent malfunction of the motor and possible damage to the commutator from worn brushes. The voltage signal is the same magnitude as the motor armature voltage.

Potential free – refer to Mod. 155B.

Similar to Mod. 155A except a microswitch on the brush holder is actuated when the brush wears to a pre-determined length. The micro-switch contact may be used to provide a signal indicating brush wear.

## Technical Description

### SPACE HEATER

Refer to Mod 280.

When operating in humid areas and under highly fluctuating ambient temperatures, condensed water can be expected inside of the motor during longer stand still periods. In those cases a space heater should be built into the motor, to prevent the occurrence of condensed water during motor stand still.

The required supply has to be advised on the order specification. Alternatively a reduced field voltage (approx 30-40% of nominal field voltage) supplied to the exciter field (terminals F1-F2) can be used for heating the motor during stand still.

The space heater has to be switched off during motor operation.

Frame	Volts	Watts	Amps
112	120	75	0.62
	240(1)	75	0.31
	480	125	0.26
132	120	90	0.75
	240(1)	90	0.38
	480	125	0.26
160 180 200	120	140	1.17
	240(1)	140	0.58
	480	125	0.26
225	120	250	2.08
	240(1)	250	1.08
	480	165	0.35
250	120	250	2.08
	240(1)	300	1.25
	480	280	0.58
280	120	306	2.55
	240(1)	306	1.28
	480	306	.64

(1) May be operated on 220 Volts

### TACHOMETER GENERATORS AND PULSE GENERATORS

Refer to Mods. 355-546.

Standard tacho generators will be fitted normally on the non-drive side bracket, connected to the motor through a backlash-free, torsionally rigid coupling.

### OVERSPEED SWITCH/DC TACHO GENERATOR COMBINATION

Refer to Mod. 355A.

Overspeed switches are used to prevent over speed or for monitoring the start of a motor. Both switch contacts – one n.c. contact and one n.o. contact – are adjusted to the requested values in the manufacturing plant before dispatch. The required values for the tripping speed have to be advised in the specification.

### PRESSURE SWITCH

Refer to Mod. 134.

For protection against cooling air loss on force ventilated motors an air pressure switch is recommended. In case of cooling air loss this pressure switch immediately gives the respective signal for warning or switch off to the protection system, to prevent the overheating of the motor windings.

The pressure switch is installed inside the motor at the air inlet end.

### BRAKES -DISC TYPE

Refer to Mod. 150-150A.

These motor mounted brakes are continuously rated, non-adjustable, electrically released and spring set applicable for both holding and stopping service within the nominal torque ratings. Brakes used for frequently repeated stopping service or other severe applications may be limited to thermal capacity and should be referred to Baldor Electric Application Engineer.

Motor mounting position, i.e., horizontal or vertical shaft up, or down, or ceiling, must be specified on the order.

Brakes can be mounted on frames through 250 on all enclosures. Frames 280 and larger must have separately mounted shoe brakes – add standard double shaft extension for customer mounting of brake wheel. For some combinations of brake and motor, the brake may extend below the motor feet. Special motor mounting is required to provide clearance. Refer to Baldor Electric for special brakes and brakes of specific manufacturer.

### SLIDE RAILS

Refer to Mod. 121.

If there is no retensioning wheel on a belt drive, the belt can be retensioned by the use of slide rails designed acc. to DIN 42 923.

The slide rail attachment to the respective motors and the slide rail dimensions are shown in the slide rail dimension sheet.

### INSTRUCTION MANUAL

Each Baldor•Reliance RPM III motor is supplied with a comprehensive instruction manual containing instructions for mounting, start-up and maintenance of the motor. These manuals must be read carefully prior to installation, operation and/or maintenance of the equipment.

## Rating Sheets and Derate Curves

Enclosure Method of Cooling	IEC Frame	Type GK	Nominal Rating At 1000 RPM kW	Derate Curves Page	Rating Sheet Page
IP23 IC17 or IP23 IC06 or IP44 IC37	112	GK1104	4.1	20	21
		GK1106	5.1	22	23
		GK1108	6.1	24	25
		GK1110	6.3	26	27
	132	GK1303	9.7	28	29
		GK1305	11.7	30	31
		GK1307	14.9	32	33
		GK1309	17.5	34	35
		GK1311	21.4	36	37
	160	GK1606	27	38	39
		GK1608	36	40	41
		GK1610	47	42	43
	180	GK1808	54	44	45
		GK1810	70	46	47
200	GK2008	96	48	49	
	LGK2008	96	48	49	
	GK2010	106	50	51	
	LGK2010	106	50	51	
225	GK2208	156	52	53	
	LGK2208	156	52	53	
	GK2210	173	54	55	
	LKG2210	173	54	55	
250	GK2508	175	56	57	
	GK2510	248	58	59	
280	GK2808	280	60	61	
	GK2810	343	62	63	
IP44-IC410 (TENV)	112	GK1104	1.5	64	65
		GK1106	1.9	66	67
		GK1108	2.4	68	69
		GK1110	2.7	70	71
	132	GK1303	2.3	72	73
		GK1305	2.7	74	75
		GK1307	3.2	76	77
		GK1309	3.5	78	79
		GK1311	4.2	80	81
	160	GK1606	6.8	82	83
		GK1608	8.7	84	85
		GK1610	9.5	86	87

## Rating Sheets and Derate Curves

VollgeblechterGleichstrom – Nebenschlußmotor fremdgekühlt  
Laminated DC – Motor with Shunt Field  
force – ventilated  
TYPE : GK1104

Schutzart .....	IP23 .....	Enclosure
Erregerleistung .....	550 W .....	Exciter Rating
Erregerzeitkonstante (ungesättigt) .....	120 ms .....	Exciter field constant (unsaturated)
Läuferträgheitsmoment I .....	0.029 kg-m <sup>2</sup> .....	Moment of Inertia
Läuferschwingmoment GD <sup>2</sup> .....	0.115 kg-m <sup>2</sup> .....	Flywheel Effect GD <sup>2</sup>
Maschinengewicht .....	84 kg .....	Motor Weight
Fremdlüfter: Fördermenge .....	4.3 m <sup>3</sup> /min .....	Blower: Air Volume
Motordaten für 380 V, 50 Hz .....	0.56 kW / 1.2 A .....	Motor data for 380 V, 50 Hz

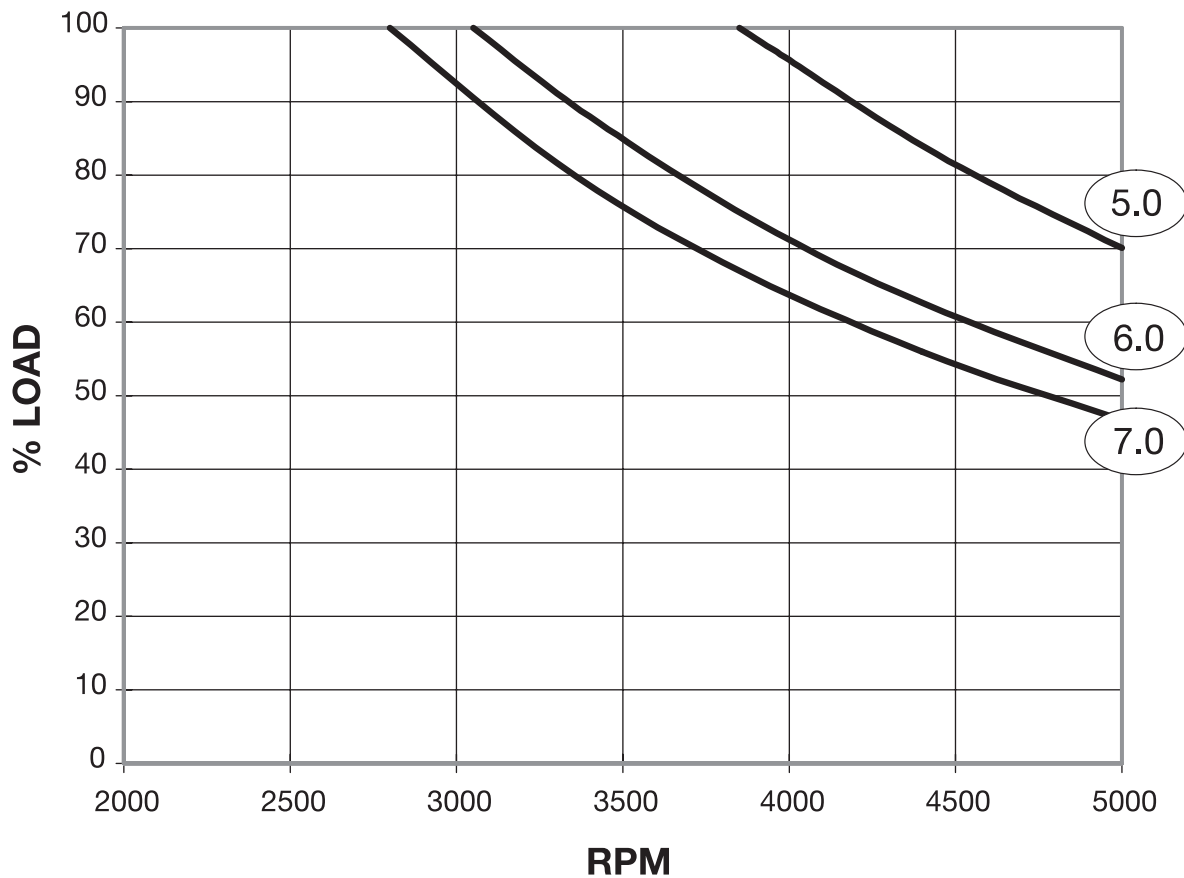

Leistungsreduktion bei Feldschwächung ..... maximal zulässige Drehzahl n = 5000 U / min  
Reduction of listed rating at Field Weakening ..... maximum safe speed n = 5000 RPM

## Rating Sheets and Derate Curves

Vollgeblechter Gleichstrom – Nebenschlußmotor  
 fremdgekühlt  
 Laminated DC – Motor with Shunt Field  
 force – ventilated  
 TYPE : GK1104

Ankerkreis Armature	Nennzahl (U/min) bei Ankerspannung Base speed (RPM) at armature voltage				Feld- steuerg Field Control U/min RPM	Nenn- leistung Nominal Rating kW	Nenn- Strom Nominal Current Amps	Wirkungs- grad Efficiency %	Ankerkreis / Armature		
	260	300	400	460					Widerstand Resistance warm Ohms	Induktivität Inductance mH	Zeit- Konstante Time- Constant ms
1.0	3605	—	—	—	4500	14.4	63.2	84	0.32	3.4	10.7
2.0	3205	3745	—	—	4500	12.7	56.5	83	0.40	4.2	10.4
3.0	2860	3350	—	—	4500	11.3	50.6	82	0.49	5.1	10.4
4.0	2560	3010	4125	—	4500	10	45.2	81	0.58	6.2	10.7
5.0	2135	2515	3455	—	3950	8.7	40.1	79	0.78	8.7	11.2
6.0	1665	1975	2740	—	3300	6.9	32.8	76	1.3	13	10.3
7.0	1450	1720	2395	2835	3000	5.9	28.8	74	1.6	17	10.8

## Rating Sheets and Derate Curves

Vollgeblechter Gleichstrom – Nebenschlußmotor  
fremdgekühlt  
Laminated DC – Motor with Shunt Field  
force – ventilated  
TYPE: GK1106

Schutzart .....	IP23 .....	Enclosure
Erregerleistung .....	600W .....	Exciter Rating
Erregerzeitkonstante (ungesättigt) .....	120 ms .....	Exciter field constant (unsaturated)
Läuferträgheitsmoment I .....	0.033 kg-m <sup>2</sup> .....	Moment of Inertia
Läuferschwingmoment GD <sup>2</sup> .....	0.13 kg-m <sup>2</sup> .....	Flywheel Effect GD <sup>2</sup>
Maschinengewicht .....	93 kg .....	Motor Weight
Fremdlüfter: Fördermenge .....	4.3 m <sup>3</sup> /min .....	Blower: Air Volume
Motordaten für 380 V, 50 Hz .....	0.56 kW / 1.2 A .....	Motor data for 380 V, 50 Hz

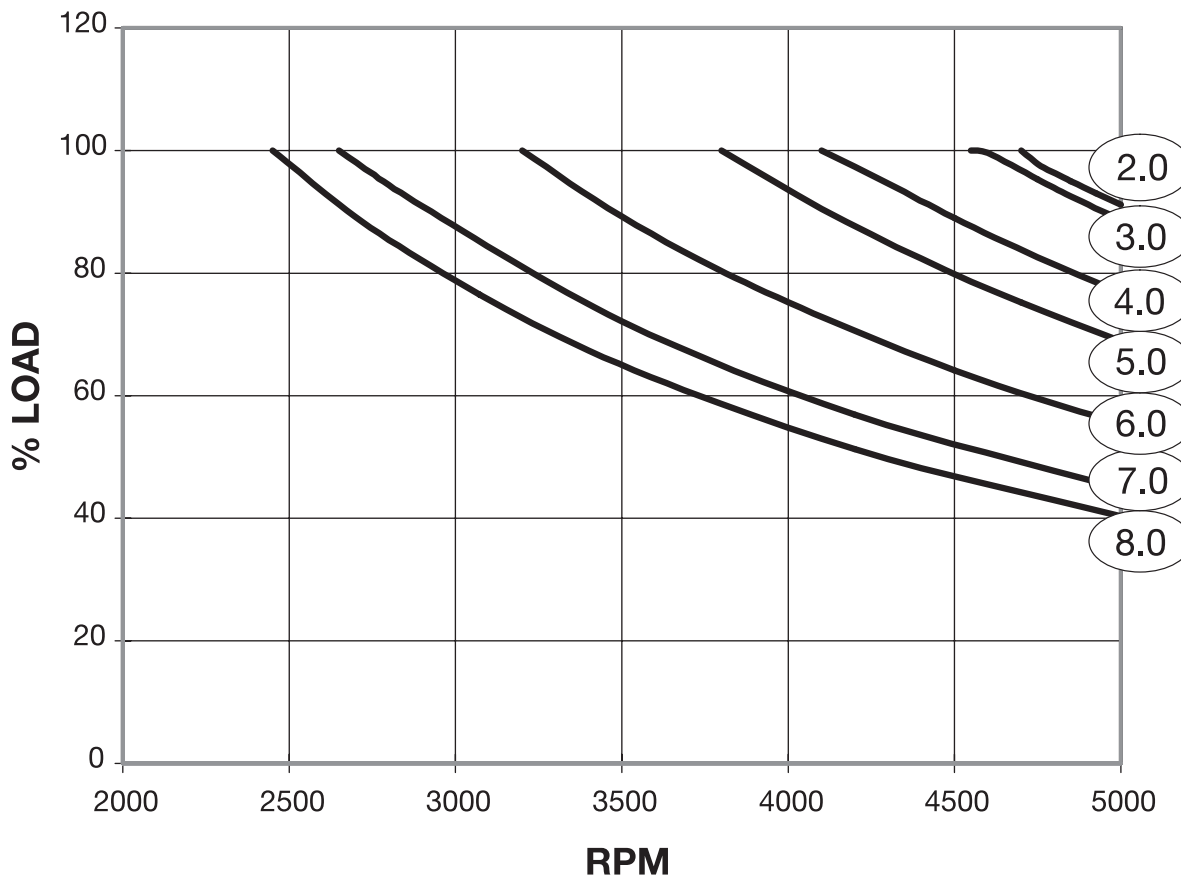

Leistungsreduktion bei Feldschwächung ..... maximal zulässige Drehzahl n = 5000 U / min  
Reduction of listed rating at Field Weakening ..... maximum safe speed n = 5000 RPM



## Rating Sheets and Derate Curves

Vollgeblechter Gleichstrom – Nebenschlußmotor  
 fremdgekühlt  
 Laminated DC – Motor with Shunt Field  
 force – ventilated  
 TYPE : GK1106

Ankerkreis Armature	Nennzahl (U/min) bei Ankerspannung Base speed (RPM) at armature voltage				Feld- steuerung Field Control U/min RPM	Nenn- leistung Nominal Rating kW	Nenn- Strom Nominal Current Amps	Wirkungs- grad Efficiency %	Ankerkreis / Armature		
	260	300	400	460					Widerstand Resistance warm Ohms	Induktivität Inductance mH	Zeit- Konstante Time- Constant ms
1.0	3245	3795	—	—	4500	15.9	69.7	85	0.29	3.3	11.6
					4500	17.8	66.6	86			
					—	—	—	—			
					—	—	—	—			
2.0	2810	3285	—	—	4500	14.2	62.9	84	0.37	4.3	11.6
					4500	16.3	61.5	85			
					—	—	—	—			
					—	—	—	—			
3.0	2485	2915	4000	—	4500	12.5	56.2	82	0.46	5.3	11.4
					4500	14.6	56	84			
					4500	18.4	51.5	87			
					—	—	—	—			
4.0	2205	2600	3560	—	4400	11.1	50.2	81	0.58	6.5	11.2
					4300	13	50.1	83			
					4100	17.1	48.1	86			
					—	—	—	—			
5.0	1975	2325	3205	3740	4100	9.7	44.7	80	0.73	7.9	10.9
					4100	11.5	44.7	82			
					3800	15.6	44.3	85			
					3800	16	38.8	86			
6.0	1635	1935	2680	3135	3400	8.5	39.8	77	0.96	11	11.5
					3400	10	39.7	80			
					3200	13.7	39.4	83			
					3200	14.6	35.8	85			
7.0	1270	1510	2110	2470	2800	6.6	32.5	73	1.5	17	11.3
					2800	7.8	32.4	76			
					2650	10.9	32.3	81			
					2650	12.7	32.2	82			
8.0	1100	1315	1850	2170	2550	5.6	28.5	70	1.85	21	11.4
					2550	6.7	28.4	74			
					2450	9.4	28.3	79			
					2450	11.1	28.3	81			

## Rating Sheets and Derate Curves

Vollgeblechter Gleichstrom – Nebenschlußmotor  
fremdgekühlt  
Laminated DC – Motor with Shunt Field  
force – ventilated  
TYPE : GK1108

Schutzart .....	IP23 .....	Enclosure
Erregerleistung .....	650W .....	Exciter Rating
Erregerzeitkonstante (ungesättigt) .....	120 ms .....	Exciter field constant (unsaturated)
Läuferträgheitsmoment I .....	0.040 kg-m <sup>2</sup> .....	Moment of Inertia
Läuferschwingmoment GD <sup>2</sup> .....	0.16 kg-m <sup>2</sup> .....	Flywheel Effect GD <sup>2</sup>
Maschinengewicht .....	111 kg .....	Motor Weight
Fremdlüfter: Fördermenge .....	4.3 m <sup>3</sup> /min .....	Blower: Air Volume
Motordaten für 380 V, 50 Hz .....	0.56 kW / 1.2 A .....	Motor data for 380 V, 50 Hz

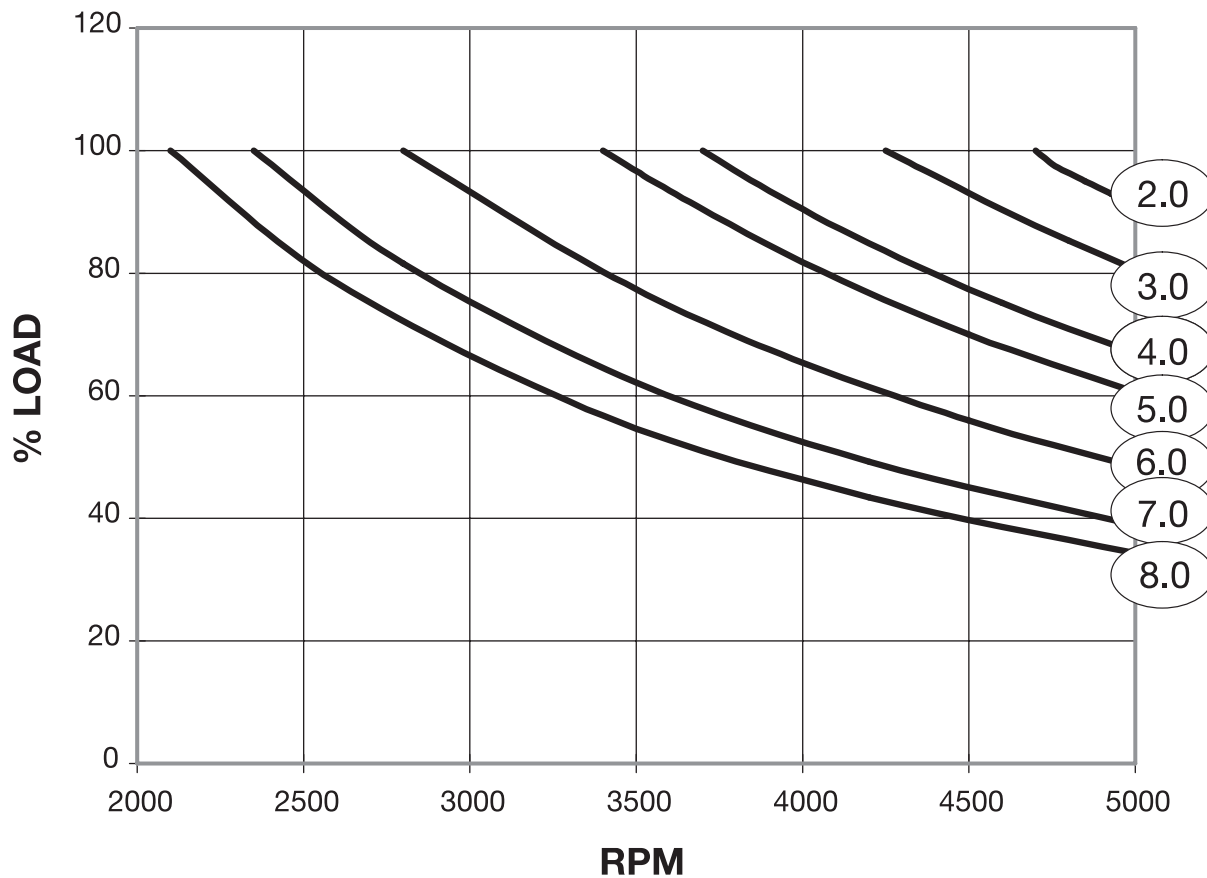

Leistungsreduktion bei Feldschwächung ..... maximal zulässige Drehzahl n = 5000 U / min  
Reduction of listed rating at Field Weakening ..... maximum safe speed n = 5000 RPM

## Rating Sheets and Derate Curves

Vollgeblechter Gleichstrom – Nebenschlußmotor  
fremdgekühlt  
Laminated DC – Motor with Shunt Field  
force – ventilated  
TYPE : GK1108

Ankerkreis Armature	Nennzahl (U/min) bei Ankerspannung Base speed (RPM) at armature voltage				Feld- steuerg Field Control U/min RPM	Nenn- leistung Nominal Rating kW	Nenn- Strom Nominal Current Amps	Wirkungs- grad Efficiency %	Ankerkreis / Armature		
	260	300	400	460					Widerstand Resistance warm Ohms	Induktivität Inductance mH	Zeit- Konstante Time- Constant ms
1.0	2505	2935	4000	—	4500	14	66.1	84	0.33	4.3	13.0
					4500	16	64	85			
					4500	19.4	56.3	87			
					—	—	—	—			
2.0	2160	2535	3475	—	4500	12.7	60	82	0.42	5.5	13.1
					4500	14.5	58.4	84			
					4500	18.2	53.4	87			
					—	—	—	—			
3.0	1905	2245	3080	3580	4200	11.3	54.1	81	0.54	6.8	12.5
					4200	13	53	83			
					4200	16.8	49.6	86			
					4200	18.6	47.3	87			
4.0	1685	1990	2745	3200	3800	10	49.2	79	0.68	8.3	12.3
					3800	11.6	48.3	81			
					3700	14.75	46	85			
					3700	17.2	44.2	86			
5.0	1500	1780	2465	2880	3550	8.9	44.4	77	0.8	10.1	11.9
					3500	10.5	44	80			
					3400	14.0	42.2	84			
					3400	15.8	41	85			
6.0	1240	1475	2055	2405	2900	7.7	39.3	75	1.1	14	12.5
					2900	9.1	38.9	78			
					2800	12.3	37.7	82			
					2800	14.1	37	84			
7.0	950	1140	1615	1900	2400	5.8	31.8	70	1.8	21	11.9
					2400	7	31.6	73			
					2350	9.7	31	79			
					2350	11.3	30.5	81			
8.0	—	985	1405	1660	—	—	—	—	2.2	27	12.2
					2150	6.0	28.1	71			
					2100	8.6	27.8	77			
					2100	10	27.5	79			

## Rating Sheets and Derate Curves

Vollgeblechter Gleichstrom – Nebenschlußmotor  
fremdgekühlt  
Laminated DC – Motor with Shunt Field  
force – ventilated  
TYPE : GK1110

Schutzart .....	IP23 .....	Enclosure
Erregerleistung .....	750 W .....	Exciter Rating
Erregerzeitkonstante (ungesättigt) .....	150 ms .....	Exciter field constant (unsaturated)
Läuferträgheitsmoment I .....	0.043 kg-m <sup>2</sup> .....	Moment of Inertia
Läuferschwingmoment GD <sup>2</sup> .....	0.17 kg-m <sup>2</sup> .....	Flywheel Effect GD <sup>2</sup>
Maschinengewicht .....	120 kg .....	Motor Weight
Fremdlüfter: Fördermenge .....	4.3 m <sup>3</sup> /min .....	Blower: Air Volume
Motordaten für 380 V, 50 Hz .....	0.56 kW / 1.2 A .....	Motor data for 380 V, 50 Hz

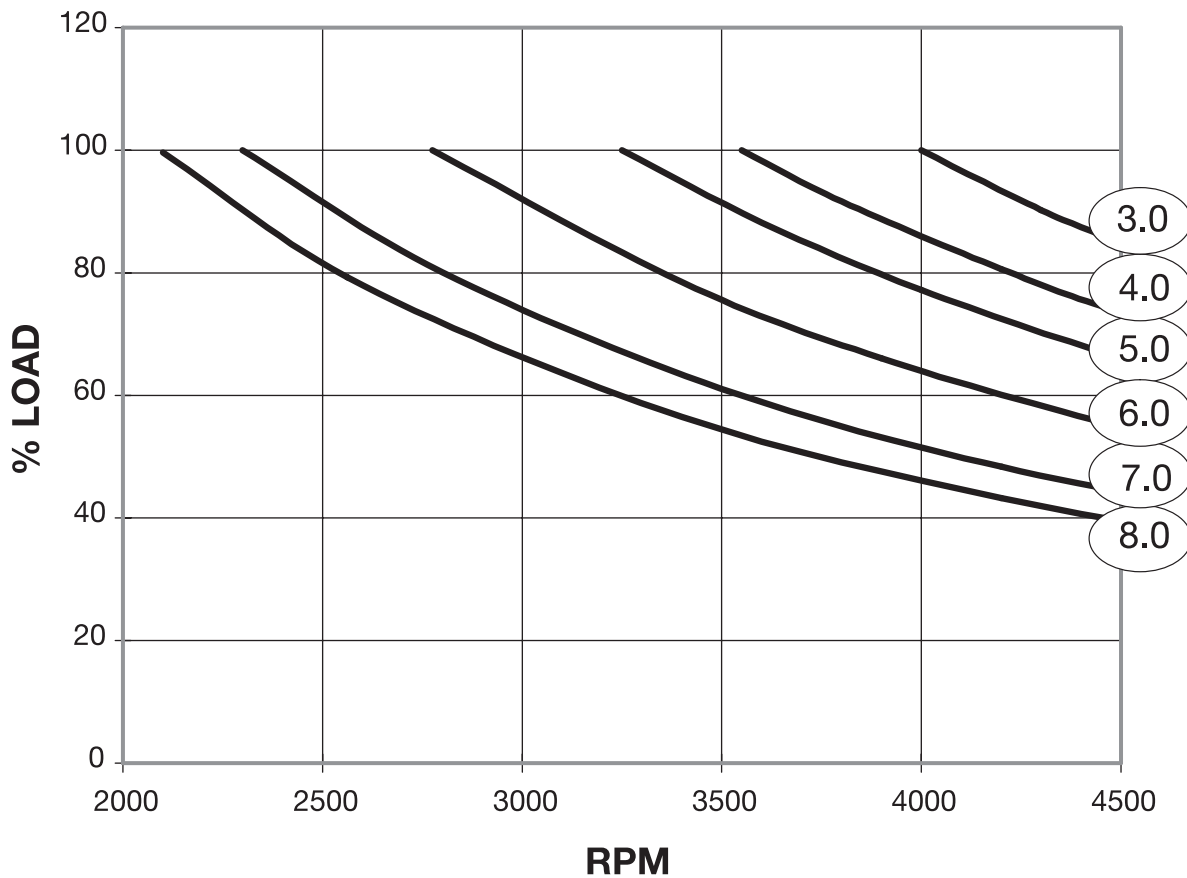

Leistungsreduktion bei Feldschwächung ..... maximal zulässige Drehzahl n = 4500 U / min  
Reduction of listed rating at Field Weakening ..... maximum safe speed n = 4500 RPM

## Rating Sheets and Derate Curves

Vollgeblechter Gleichstrom – Nebenschlußmotor  
 fremdgekühlt  
 Laminated DC – Motor with Shunt Field  
 force – ventilated  
 TYPE : GK1110

Ankerkreis Armature	Nennzahl (U/min) bei Ankerspannung Base speed (RPM) at armature voltage				Feld- steuerg Field Control U/min RPM	Nenn- leistung Nominal Rating kW	Nenn- Strom Nominal Current Amps	Wirkungs- grad Efficiency %	Ankerkreis / Armature		
	260	300	400	460					Widerstand Resistance warm Ohms	Induktivität Inductance mH	Zeit- Konstante Time- Constant ms
1.0	2250	2630	3575	4145	4500	12.5	57.6	84	0.35	4.7	13.4
					4500	14.5	57.2	85			
					4500	18.8	54.8	87			
					4500	20.8	52.2	88			
2.0	1930	2270	3105	3605	4500	11.9	56.1	82	0.45	6.1	13.5
					4500	13.7	55	84			
					4500	17.7	51.9	86			
					4500	19.6	49.6	87			
3.0	1700	2000	2750	3200	4250	10.6	50.6	80	0.58	7.5	13.0
					4150	12.4	50.4	82			
					4000	16.1	47.8	85			
					4150	18	45.8	87			
4.0	1500	1770	2450	2855	3750	9.6	46.4	78	0.72	9.3	12.8
					3700	11.2	46.4	81			
					3550	15	44.7	84			
					3650	16.9	43.4	86			
5.0	1335	1580	2195	2570	3425	8.5	42.3	76	0.91	11	12.1
					3425	9.9	42	79			
					3250	13.5	41.1	83			
					3350	15.2	39.5	85			
6.0	1115	1320	1835	2150	2950	7.1	36	74	1.2	16	13.6
					2900	8.4	35.9	77			
					2775	11.6	35.6	82			
					2850	13.3	34.8	84			
7.0	—	1025	1445	1695	—	—	—	—	1.9	24	13.0
					2450	6.5	29	73			
					2300	9.2	29	78			
8.0	—	—	1260	1485	—	—	—	—	2.30	30.0	13.0
					2100	7.9	25.5	76			
					2100	9.4	25.7	79			

## Rating Sheets and Derate Curves

Vollgeblechter Gleichstrom – Nebenschlußmotor  
fremdgekühlt  
Laminated DC – Motor with Shunt Field  
force – ventilated  
TYPE : GK1303

Schutzart .....	IP23 .....	Enclosure
Erregerleistung .....	750W .....	Exciter Rating
Erregerzeitkonstante (ungesättigt) .....	150 ms .....	Exciter field constant (unsaturated)
Läuferträgheitsmoment I .....	0.098 kg-m <sup>2</sup> .....	Moment of Inertia
Läuferschwingmoment GD <sup>2</sup> .....	0.39 kg-m <sup>2</sup> .....	Flywheel Effect GD <sup>2</sup>
Maschinengewicht .....	154 kg .....	Motor Weight
Fremdlüfter: Fördermenge .....	8.4 m <sup>3</sup> /min .....	Blower: Air Volume
Motordaten für 380 V, 50 Hz .....	0.56 kW / 1.2 A .....	Motor data for 380 V, 50 Hz

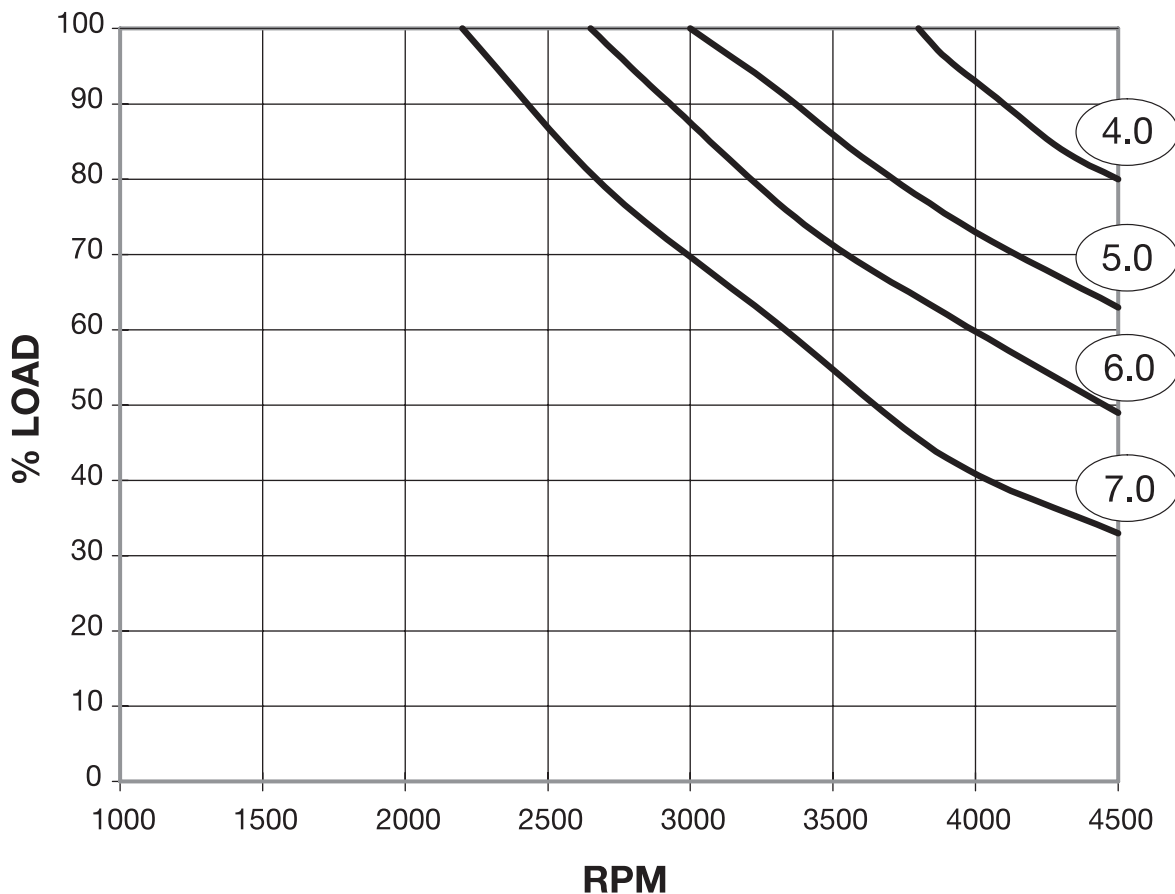

Leistungsreduktion bei Feldschwächung ..... maximal zulässige Drehzahl n = 4500 U / min  
Reduction of listed rating at Field Weakening ..... maximum safe speed n = 4500 RPM

## Rating Sheets and Derate Curves

Vollgeblechter Gleichstrom – Nebenschlußmotor  
fremdgekühlt  
Laminated DC – Motor with Shunt Field  
force – ventilated  
TYPE : GK1303

Ankerkreis Armature	Nennzahl (U/min) bei Ankerspannung Base speed (RPM) at armature voltage				Feld- steuerg Field Control U/min RPM	Nenn- leistung Nominal Rating kW	Nenn- Strom Nominal Current Amps	Wirkungs- grad Efficiency %	Ankerkreis / Armature		
	260	300	400	460					Widerstand Resistance warm Ohms	Induktivität Inductance mH	Zeit- Konstante Time- Constant ms
1.0	3010	3525	—	—	4200	26.7	118	84	0.19	1.7	9.0
					4200	30.6	116	86			
					—	—	—	—			
					—	—	—	—			
2.0	2425	2845	3885	—	4200	23.5	106	83	0.26	2.5	9.6
					4200	27.4	105	84			
					4200	35.6	100	87			
					—	—	—	—			
3.0	2090	2460	3375	—	4200	20	91	81	0.34	3.3	9.8
					4200	23.2	90	83			
					4150	31.2	88	86			
					—	—	—	—			
4.0	1790	2115	2915	3395	4200	16.4	76	79	0.46	4.4	9.5
					4200	19.1	75	81			
					3800	26.3	75	85			
					3800	30.5	75	86			
5.0	1375	1635	2280	2670	3200	13.4	65	75	0.70	6.9	9.9
					3200	15.9	65	78			
					3000	21.9	64	82			
					3000	25.5	64	84			
6.0	1105	1325	1865	2185	2700	10.9	55	72	1.0	10	10.1
					2700	13.1	55	75			
					2650	17.6	52.5	81			
					2650	20.5	52	83			
7.0	820	995	1430	1690	2250	8	43.5	66	1.6	15	9.6
					2250	9.7	43.5	70			
					2200	13.6	42.2	77			
					2200	15.9	41.8	79			

## Rating Sheets and Derate Curves

Vollgeblechter Gleichstrom – Nebenschlußmotor  
fremdgekühlt  
Laminated DC – Motor with Shunt Field  
force – ventilated  
TYPE : GK1305

Schutzart .....	IP23 .....	Enclosure
Erregerleistung .....	850 W .....	Exciter Rating
Erregerzeitkonstante (ungesättigt) .....	150 ms .....	Exciter field constant (unsaturated)
Läuferträgheitsmoment I .....	0.11 kg-m <sup>2</sup> .....	Moment of Inertia
Läuferschwingmoment GD <sup>2</sup> .....	0.43 kg-m <sup>2</sup> .....	Flywheel Effect GD <sup>2</sup>
Maschinengewicht .....	166 kg .....	Motor Weight
Fremdlüfter: Fördermenge .....	8.4 m <sup>3</sup> /min .....	Blower: Air Volume
Motordaten für 380 V, 50 Hz .....	0..56 kW / 1.2 A .....	Motor data for 380 V, 50 Hz

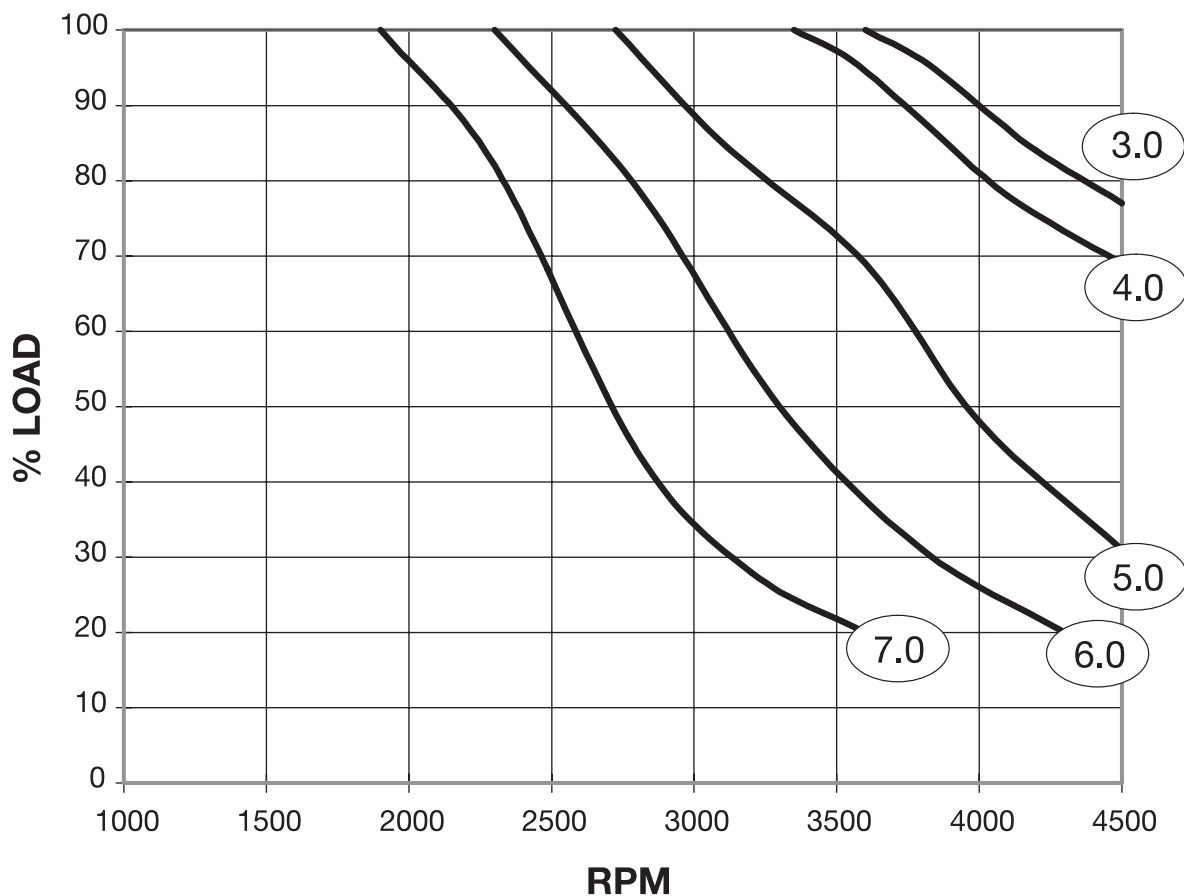

Leistungsreduktion bei Feldschwächung ..... maximal zulässige Drehzahl n = 4500 U / min  
Reduction of listed rating at Field Weakening ..... maximum safe speed n = 4500 RPM



## Rating Sheets and Derate Curves

Vollgeblechter Gleichstrom – Nebenschlußmotor  
fremdgekühlt  
Laminated DC – Motor with Shunt Field  
force – ventilated  
TYPE : GK1305

Ankerkreis Armature	Nennzahl (U/min) bei Ankerspannung Base speed (RPM) at armature voltage				Feld- steuerg Field Control U/min RPM	Nenn- leistung Nominal Rating kW	Nenn- Strom Nominal Current Amps	Wirkungs- grad Efficiency %	Ankerkreis / Armature		
	300	400	460	520					Widerstand Resistance warm Ohms	Induktivität Inductance mH	Zeit- Konstante Time- Constant ms
1.0	2800	3815	—	—	4200	30.2	115	85	0.21	2.1	9.9
					4200	39	109	87			
					—	—	—	—			
2.0	2310	3165	—	—	4200	26.9	104	83	0.29	2.9	10.1
					4200	36.2	102	86			
					—	—	—	—			
3.0	2005	2765	3220	—	4000	23	90	82	0.38	3.9	10.3
					3600	31.6	90	85			
					3600	36	88	87			
4.0	1710	2370	2765	—	3700	19	76	80	0.52	5.2	10.1
					3350	26	75	84			
					3350	30.3	75	85			
5.0	1315	1840	2160	2480	2800	15.5	64.5	76	0.80	8.2	10.3
					2725	21.7	64.5	81			
					2725	25.2	64	83			
6.0	1060	1505	1775	2040	2400	12.8	55	73	1.1	12	10.9
					2300	17.8	54	79			
					2300	20.8	53.5	81			
7.0	795	1150	1368	1580	2000	9.3	43	67	1.8	18.0	10.3
					1900	13.5	43	74			
					1900	16	43	77			
					1900	18.1	42	80			

## Rating Sheets and Derate Curves

Vollgeblechter Gleichstrom – Nebenschlußmotor  
fremdgekühlt  
Laminated DC – Motor with Shunt Field  
force – ventilated  
TYPE : GK1307

Schutzart .....	IP23 .....	Enclosure
Erregerleistung .....	1100 W .....	Exciter Rating
Erregerzeitkonstante (ungesättigt) .....	150 ms .....	Exciter field constant (unsaturated)
Läuferträgheitsmoment I .....	0.12 kg-m <sup>2</sup> .....	Moment of Inertia
Läuferschwingmoment GD <sup>2</sup> .....	0.48 kg-m <sup>2</sup> .....	Flywheel Effect GD <sup>2</sup>
Maschinengewicht .....	179 kg .....	Motor Weight
Fremdlüfter: Fördermenge .....	8.4 m <sup>3</sup> /min .....	Blower: Air Volume
Motordaten für 380 V, 50 Hz .....	0.56 kW / 1.2 A .....	Motor data for 380 V, 50 Hz

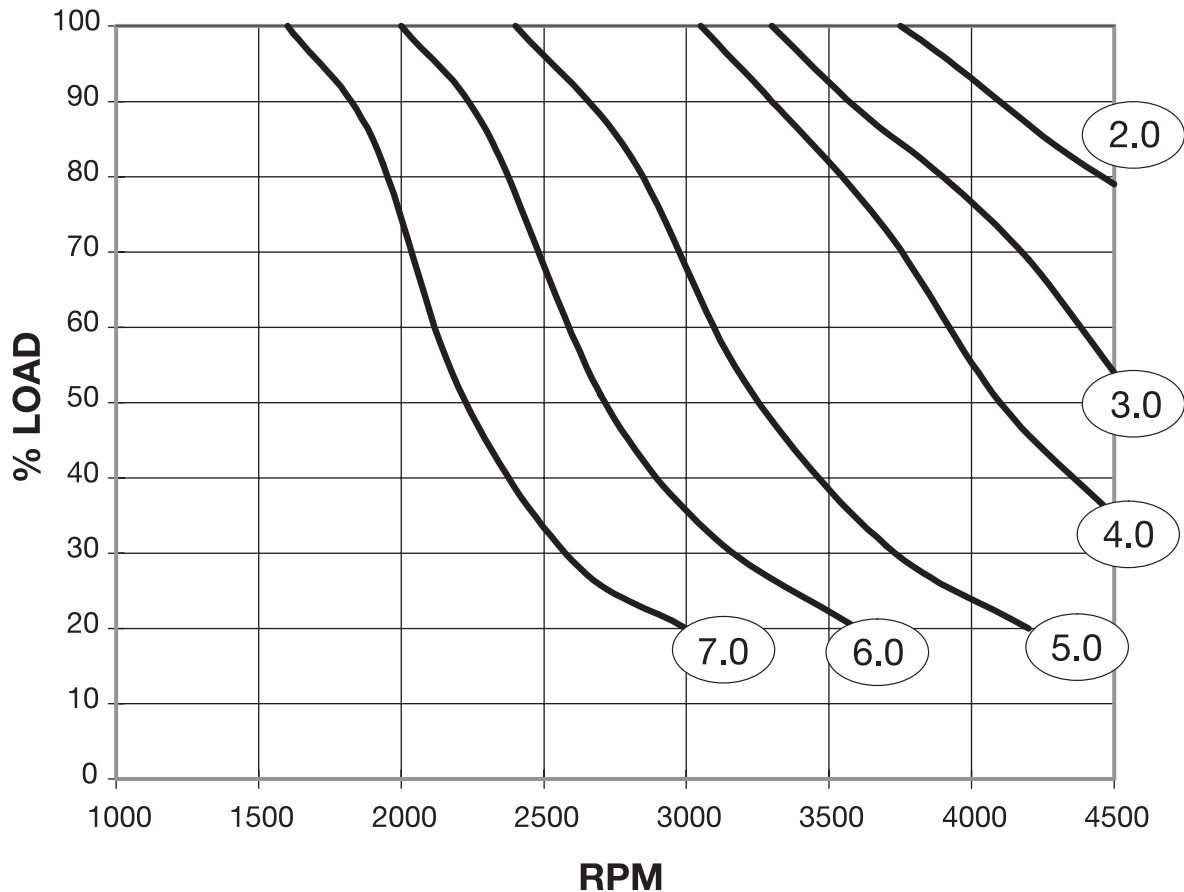

Leistungsreduktion bei Feldschwächung ..... maximal zulässige Drehzahl n = 4500 U / min  
Reduction of listed rating at Field Weakening ..... maximum safe speed n = 4500 RPM

## Rating Sheets and Derate Curves

Vollgeblechter Gleichstrom – Nebenschlußmotor  
fremdgekühlt  
Laminated DC – Motor with Shunt Field  
force – ventilated  
TYPE : GK1307

Ankerkreis Armature	Nennzahl (U/min) bei Ankerspannung Base speed (RPM) at armature voltage				Feld- steuerg Field Control U/min RPM	Nenn- leistung Nominal Rating kW	Nenn- Strom Nominal Current Amps	Wirkungs- grad Efficiency %	Ankerkreis / Armature		
	300	400	460	520					Widerstand Resistance warm Ohms	Induktivität Inductance mH	Zeit- Konstante Time- Constant ms
1.0	2060	3095	3595	—	4200	29.9	115	84	0.24	2.5	10.3
					4200	39.9	112	86			
					4200	45.1	109	87			
					—	—	—	—			
2.0	1810	2500	2910	3320	4200	26.5	104	82	0.33	3.5	10.6
					3750	35.5	101	85			
					3750	40.9	100	86			
					3750	45.8	98	87			
3.0	1550	2150	2510	2865	3500	22.6	90	80	0.43	4.8	11.1
					3300	30.6	88	84			
					3300	35.7	88	85			
					3300	39.9	86	87			
4.0	1325	1850	2185	2500	3200	18.6	76	78	0.59	6.3	10.7
					3050	25.7	75	82			
					3050	29.7	74	84			
					3050	33.5	73	85			
5.0	1010	1435	1685	1940	2500	15	64.5	73	0.90	9.9	11.0
					2400	21.1	64	79			
					2400	24.7	63.5	81			
					2400	28.2	63	83			
6.0	810	1165	1375	1590	2050	12.3	55	70	1.2	14	11.4
					2000	17.4	54	76			
					2000	20.6	54	79			
					2000	23.3	53	81			
7.0	600	880	1045	1215	1600	8.9	43	63	2.0	22.0	11.0
					1600	13.1	43	71			
					1600	15.6	43	74			
					1600	18.1	43	77			

## Rating Sheets and Derate Curves

Vollgeblechter Gleichstrom – Nebenschlußmotor  
fremdgekühlt  
Laminated DC – Motor with Shunt Field  
force – ventilated  
TYPE : GK1309

Schutzart .....	IP23 .....	Enclosure
Erregerleistung .....	1050 W .....	Exciter Rating
Erregerzeitkonstante (ungesättigt) .....	150 ms .....	Exciter field constant (unsaturated)
Läuferträgheitsmoment I .....	0.13 kg-m <sup>2</sup> .....	Moment of Inertia
Läuferschwingmoment GD <sup>2</sup> .....	0.52 kg-m <sup>2</sup> .....	Flywheel Effect GD <sup>2</sup>
Maschinengewicht .....	191 kg .....	Motor Weight
Fremdlüfter: Fördermenge .....	8.4 m <sup>3</sup> /min .....	Blower: Air Volume
Motordaten für 380 V, 50 Hz .....	0.56 kW / 1.2 A .....	Motor data for 380 V, 50 Hz

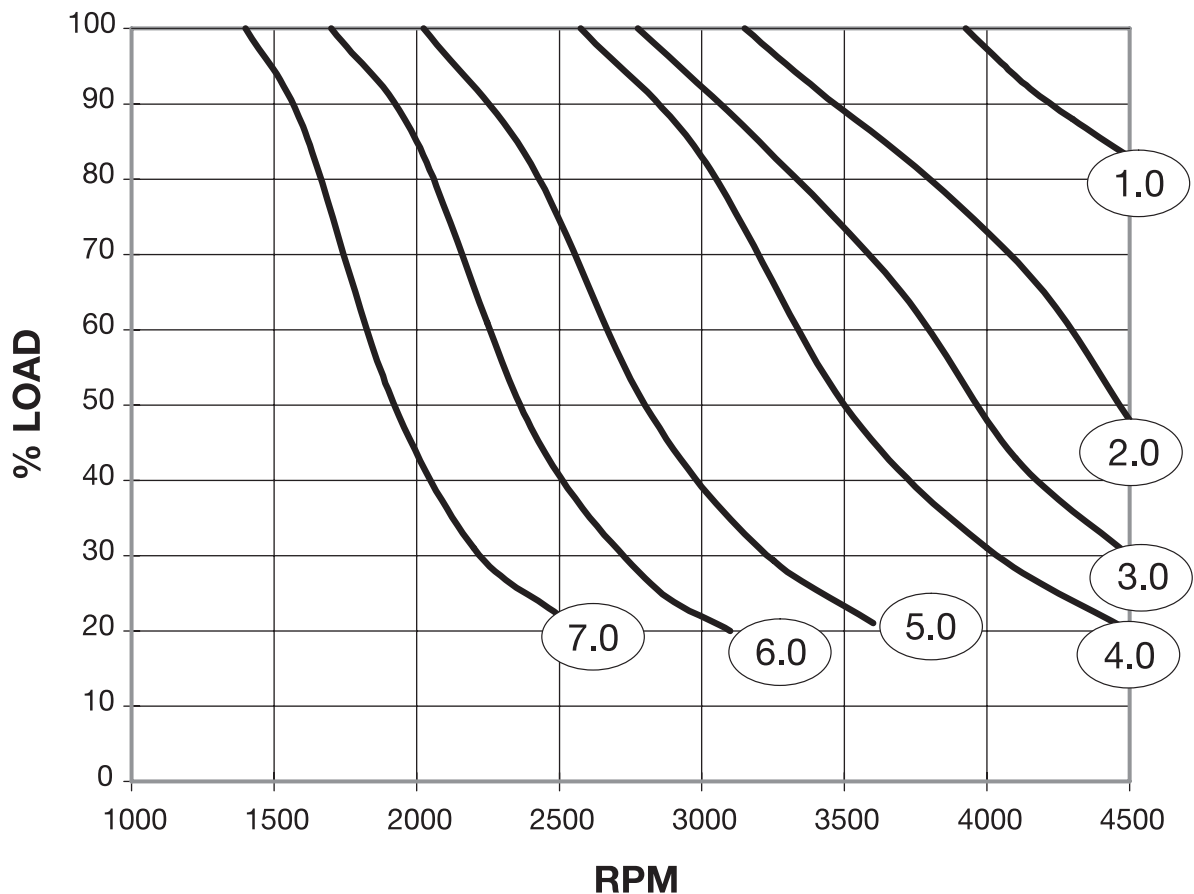

Leistungsreduktion bei Feldschwächung ..... maximal zulässige Drehzahl n = 4500 U / min  
Reduction of listed rating at Field Weakening ..... maximum safe speed n = 4500 RPM

## Rating Sheets and Derate Curves

Vollgeblechter Gleichstrom – Nebenschlußmotor  
 fremdgekühlt  
 Laminated DC – Motor with Shunt Field  
 force – ventilated  
 TYPE : GK1309

Ankerkreis Armature	Nennzahl (U/min) bei Ankerspannung Base speed (RPM) at armature voltage				Feld- steuerg Field Control U/min RPM	Nenn- leistung Nominal Rating kW	Nenn- Strom Nominal Current Amps	Wirkungs- grad Efficiency %	Ankerkreis / Armature		
	300	400	460	520					Widerstand Resistance warm Ohms	Induktivität Inductance mH	Zeit- Konstante Time- Constant ms
1.0	2010	2770	3225	—	4200	32.7	128	82	0.27	2.8	10.5
					3900	44	125	86			
					3900	50	122	87			
					—	—	—	—			
2.0	1595	2215	2590	2960	3350	28.4	114	80	0.36	4.0	11.1
					3150	39.4	114	84			
					3150	45.2	112	86			
					3150	50.8	110	87			
3.0	1365	1910	2240	2565	2900	24.1	99	78	0.47	5.4	11.4
					2775	33.4	98	83			
					2775	38.7	97	84			
					2775	43.5	95	86			
4.0	1175	1655	1945	2230	2650	19.5	82	76	0.64	7.1	11.1
					2575	27.5	82	81			
					2575	31.9	81	83			
					2575	36.6	81	84			
5.0	880	1260	1490	1725	2100	15.4	69	71	0.99	11.2	11.3
					2050	22.1	69	77			
					2050	26.2	69	79			
					2025	30.2	69	81			
6.0	705	1025	1215	1410	1800	12.4	58	67	1.33	16	12.0
					1700	18.1	58	74			
					1700	21.5	58	77			
					1700	24.5	57	80			
7.0	—	760	915	1070	—	—	—	—	2.2	25.0	11.6
					1400	13.4	46	68			
					1400	16.1	46	72			
					1400	18.8	46	75			

## Rating Sheets and Derate Curves

Vollgeblechter Gleichstrom – Nebenschlußmotor  
fremdgekühlt  
Laminated DC – Motor with Shunt Field  
force – ventilated  
TYPE : GK1311

Schutzart .....	IP23 .....	Enclosure
Erregerleistung .....	1350 W .....	Exciter Rating
Erregerzeitkonstante (ungesättigt) .....	150 ms .....	Exciter field constant (unsaturated)
Läuferträgheitsmoment I .....	0.15 kg-m <sup>2</sup> .....	Moment of Inertia
Läuferschwingmoment GD <sup>2</sup> .....	0.61 kg-m <sup>2</sup> .....	Flywheel Effect GD <sup>2</sup>
Maschinengewicht .....	215 kg .....	Motor Weight
Fremdlüfter: Fördermenge .....	8.4 m <sup>3</sup> /min .....	Blower: Air Volume
Motordaten für 380 V, 50 Hz .....	0.56 kW / 1.2 A .....	Motor data for 380 V, 50 Hz

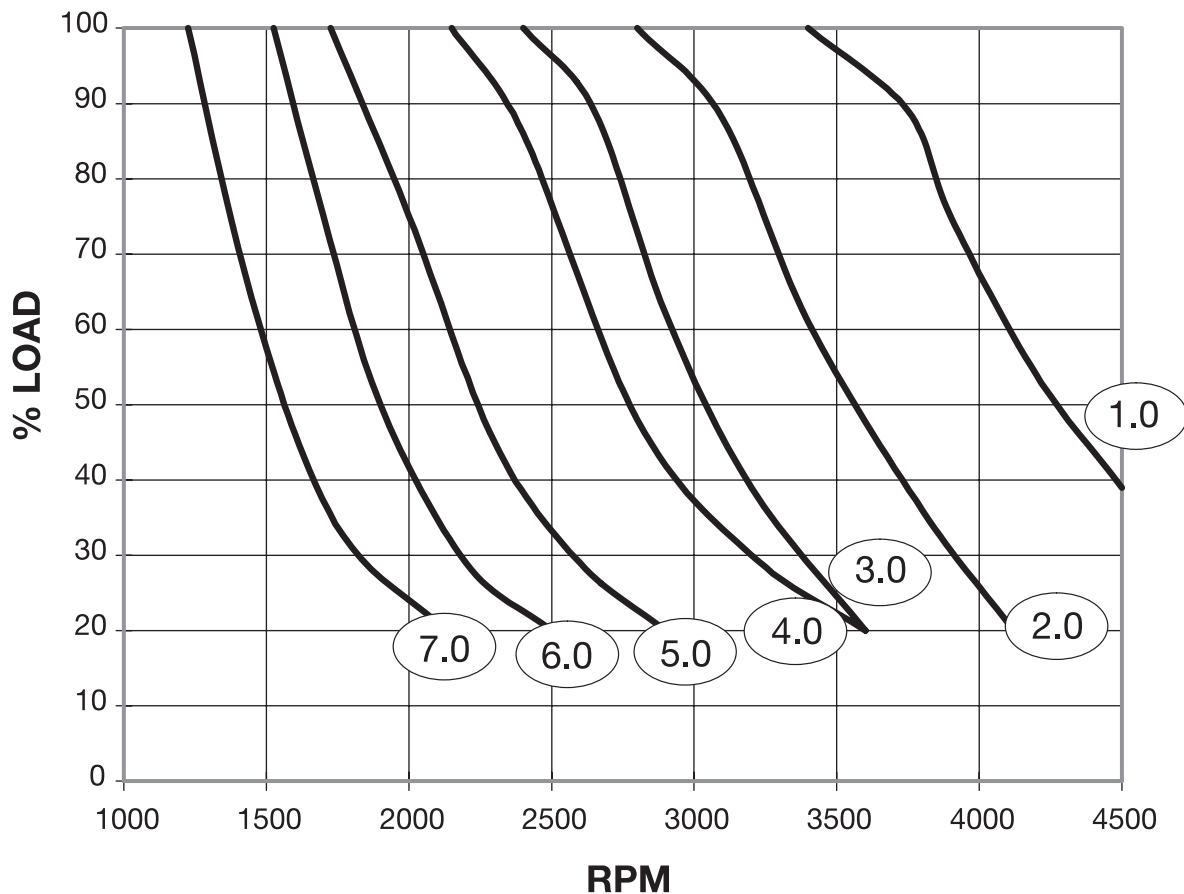

Leistungsreduktion bei Feldschwächung ..... maximal zulässige Drehzahl n = 4500 U / min  
Reduction of listed rating at Field Weakening ..... maximum safe speed n = 4500 RPM

## Rating Sheets and Derate Curves

Vollgeblechter Gleichstrom – Nebenschlußmotor  
fremdgekühlt  
Laminated DC – Motor with Shunt Field  
force – ventilated  
TYPE : GK1311

Ankerkreis Armature	Nennzahl (U/min) bei Ankerspannung Base speed (RPM) at armature voltage				Feld- steuerg Field Control U/min RPM	Nenn- leistung Nominal Rating kW	Nenn- Strom Nominal Current Amps	Wirkungs- grad Efficiency %	Ankerkreis / Armature		
	300	400	460	520					Widerstand Resistance warm Ohms	Induktivität Inductance mH	Zeit- Konstante Time- Constant ms
1.0	1515	2110	2420	2770	3600	31.5	126	80	0.32	3.6	11.2
					3325	43.6	126	84			
					3400	49.7	123	85			
					3400	55.9	121	86			
2.0	1215	1700	1985	2290	3025	26.1	106	79	0.42	5.0	11.9
					2850	36.3	106	83			
					2850	42.4	106	84			
					2800	48.5	106	85			
3.0	1030	1450	1675	1925	2500	22.8	96	75	0.56	6.9	12.3
					2400	31.8	95	80			
					2400	36.9	94	82			
					2400	41.9	93	84			
4.0	870	1240	1460	1690	2300	18.6	81	72	0.76	8.9	11.7
					2200	26.4	81	78			
					2200	31.2	81	80			
					2150	36.2	82	82			
5.0	655	945	1125	1300	1825	14.4	66.5	67	1.17	14	12.0
					1725	21.1	68	74			
					1725	24.9	67.5	77			
					1725	28.8	67.5	79			
6.0	535	775	920	1070	1625	11.2	52.5	65	1.53	20	13.1
					1525	16.6	54	72			
					1525	19.7	54	75			
					1525	22.9	54	77			
7.0	—	580	690	800	—	—	—	—	2.50	31.0	12.4
					1275	12.1	42	67			
					1250	14.7	43	69			
					1225	17.5	44	72			

## Rating Sheets and Derate Curves

Vollgeblechter Gleichstrom – Nebenschlußmotor  
fremdgekühlt  
Laminated DC – Motor with Shunt Field  
force – ventilated  
TYPE : GK1606

Schutzart .....	IP23 .....	Enclosure
Erregerleistung .....	1200 W .....	Exciter Rating
Erregerzeitkonstante (ungesättigt) .....	280 ms .....	Exciter field constant (unsaturated)
Läuferträgheitsmoment I .....	0.26 kg-m <sup>2</sup> .....	Moment of Inertia
Läuferschwingmoment GD <sup>2</sup> .....	1.0 kg-m <sup>2</sup> .....	Flywheel Effect GD <sup>2</sup>
Maschinengewicht .....	274 kg .....	Motor Weight
Fremdlüfter: Fördermenge .....	12 m <sup>3</sup> /min .....	Blower: Air Volume
Motordaten für 380 V, 50 Hz .....	0.56 kW / 1.2 A .....	Motor data for 380 V, 50 Hz

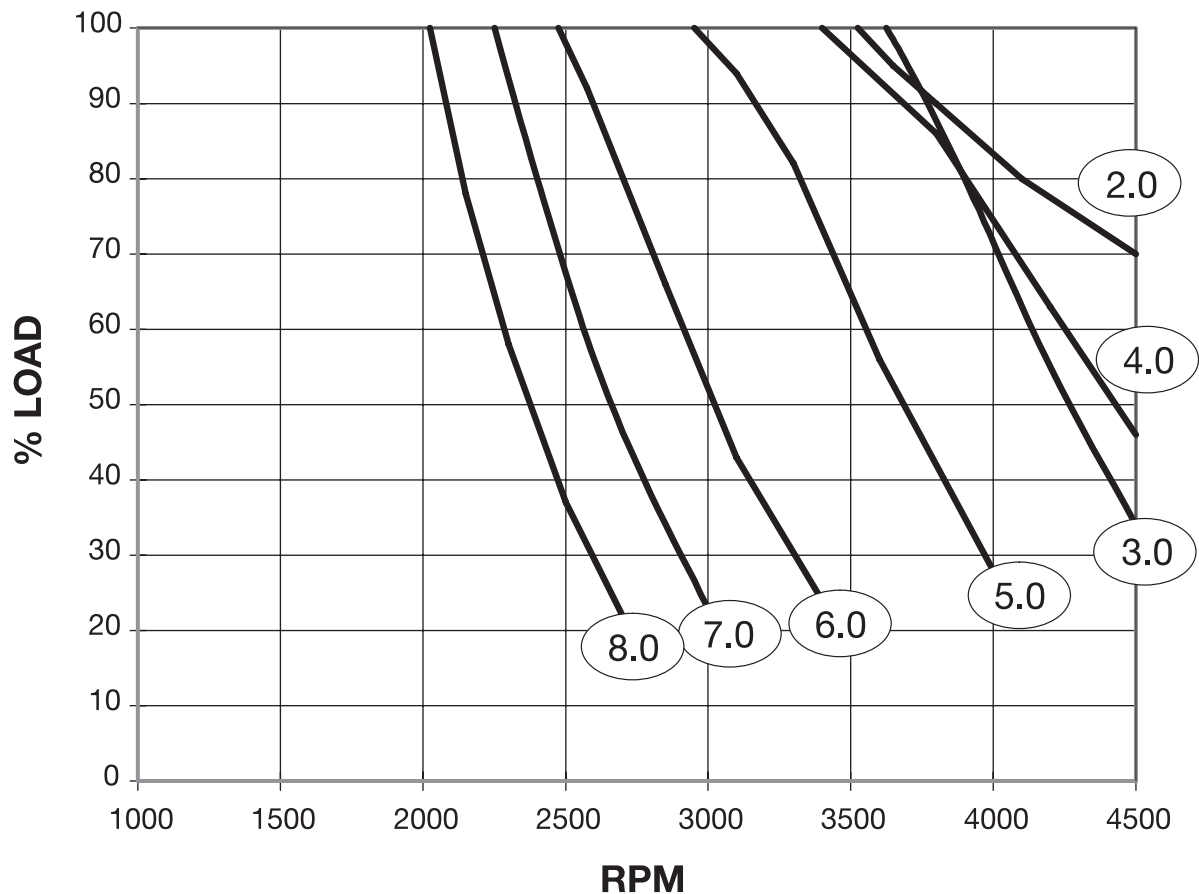

Leistungsreduktion bei Feldschwächung ..... maximal zulässige Drehzahl n = 4500 U / min  
Reduction of listed rating at Field Weakening ..... maximum safe speed n = 4500 RPM



## Rating Sheets and Derate Curves

Vollgeblechter Gleichstrom – Nebenschlußmotor  
fremdgekühlt  
Laminated DC – Motor with Shunt Field  
force – ventilated  
TYPE : GK1606

Ankerkreis Armature	Nennzahl (U/min) bei Ankerspannung Base speed (RPM) at armature voltage				Feld- steuerg Field Control U/min RPM	Nenn- leistung Nominal Rating kW	Nenn- Strom Nominal Current Amps	Wirkungs- grad Efficiency %	Ankerkreis / Armature		
	400	460	520	600					Widerstand Resistance warm Ohms	Induktivität Inductance mH	Zeit- Konstante Time- Constant ms
1.0	3255	3750	—	—	4250	70.8	194	89	0.087	1.44	16.5
					4250	75.1	178	90			
					—	—	—	—			
					—	—	—	—			
2.0	2925	3385	—	—	3525	70.6	193	89	0.094	1.58	16.8
					3525	79.1	187	90			
					—	—	—	—			
					—	—	—	—			
3.0	2625	3035	3445	—	3450	65.4	180	89	0.122	2.07	17.0
					3500	73.3	174	89			
		3500			79.9	167	90				
					—	—	—	—			
4.0	2055	2390	2725	3170	3450	53.7	150	87	0.19	3.3	17.2
					3450	62.4	150	88			
		3450			70.6	149	89				
		3250			80.4	146	90				
5.0	1630	1905	2180	2540	3075	41.5	119	84	0.32	4.74	14.8
					3075	47.9	118	86			
		3050			54.8	118	87				
		2950			62.8	116	88				
6.0	1355	1590	1820	2125	2525	35.8	104	83	0.42	6.48	15.3
					2525	41	102	85			
		2500			46.9	102	86				
		2475			54.9	102	87				
7.0	1160	1360	1565	1830	2300	31.2	92	82	0.54	8.5	15.6
					2300	36.6	92	84			
		2300			41.7	91.5	85				
		2250			47.5	89	86				
8.0	1010	1190	1370	1610	2075	27	81.5	79	0.72	10.7	14.8
					2075	31.7	81.5	82			
		2075			36.5	81.5	83				
		2025			42	80	85				

## Rating Sheets and Derate Curves

Vollgeblechter Gleichstrom – Nebenschlußmotor  
fremdgekühlt  
Laminated DC – Motor with Shunt Field  
force – ventilated  
TYPE : GK1608

Schutzart .....	IP23 .....	Enclosure
Erregerleistung .....	1500 W .....	Exciter Rating
Erregerzeitkonstante (ungesättigt) .....	280 ms .....	Exciter field constant (unsaturated)
Läuferträgheitsmoment I .....	0.32 kg-m <sup>2</sup> .....	Moment of Inertia
Läuferschwungmoment GD <sup>2</sup> .....	1.3 kg-m <sup>2</sup> .....	Flywheel Effect GD <sup>2</sup>
Maschinengewicht .....	313 kg .....	Motor Weight
Fremdlüfter: Fördermenge .....	11 m <sup>3</sup> /min .....	Blower: Air Volume
Motordaten für 380 V, 50 Hz .....	0.56 kW / 1.2 A .....	Motor data for 380 V, 50 Hz

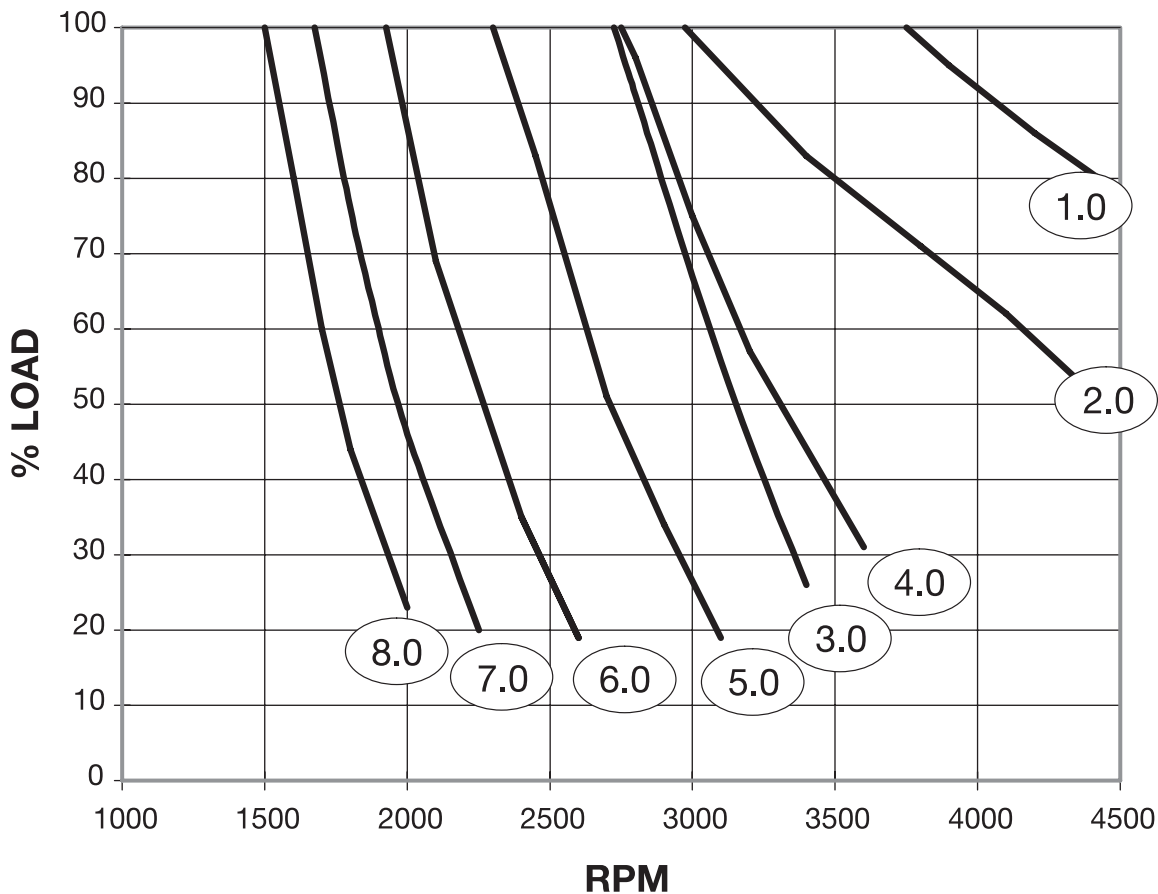

Leistungsreduktion bei Feldschwächung ..... maximal zulässige Drehzahl n = 4500 U / min  
Reduction of listed rating at Field Weakening ..... maximum safe speed n = 4500 RPM

## Rating Sheets and Derate Curves

Vollgeblechter Gleichstrom – Nebenschlußmotor  
fremdgekühlt  
Laminated DC – Motor with Shunt Field  
force – ventilated  
TYPE : GK1608

Ankerkreis Armature	Nennzahl (U/min) bei Ankerspannung Base speed (RPM) at armature voltage				Feld- steuerg Field Control U/min RPM	Nenn- leistung Nominal Rating kW	Nenn- Strom Nominal Current Amps	Wirkungs- grad Efficiency %	Ankerkreis / Armature		
	400	460	520	600					Widerstand Resistance warm Ohms	Induktivität Inductance mH	Zeit- Konstante Time- Constant ms
1.0	2360	2735	3105	—	3650	71.2	196	88	0.11	1.91	17.7
					3650	80.8	192	89			
					3650	87.9	184	90			
2.0	2120	2460	—	—	2775	71.2	196	88	0.12	2.08	17.9
					2675	80	190	89			
					—	—	—	—			
3.0	1900	2205	2505	—	2750	64.7	180	87	0.15	2.73	18.2
					2800	74.3	178	88			
					2725	82.8	174	89			
4.0	1480	1725	1970	2295	2850	53.2	151	85	0.24	4.35	18.4
					2850	60.3	147	87			
					2825	68.4	146	88			
					2750	79.2	145	89			
5.0	1165	1365	1565	1830	2475	41.9	123	82	0.39	6.26	16.1
					2475	49	123	84			
					2425	54.8	120	85			
					2300	63.1	118	87			
6.0	965	1135	1305	1530	2050	35.5	106	80	0.52	8.56	16.5
					2050	41.3	105	82			
					2025	47.4	105	84			
					1925	55.1	104	86			
7.0	830	975	1125	1320	1850	30.1	91.5	79	0.67	11.3	16.9
					1800	35.5	91.5	81			
					1750	40.8	91.5	83			
					1675	47.7	91	84			
8.0	710	845	975	1150	1650	25.8	81	76	0.89	14	15.8
					1625	30.5	81	78			
					1575	35.3	81	81			
					1500	41.4	80.5	83			

## Rating Sheets and Derate Curves

Vollgeblechter Gleichstrom – Nebenschlußmotor  
fremdgekühlt  
Laminated DC – Motor with Shunt Field  
force – ventilated  
TYPE : GK1610

Schutzart .....	IP23 .....	Enclosure
Erregerleistung .....	1900 W .....	Exciter Rating
Erregerzeitkonstante (ungesättigt) .....	300 ms .....	Exciter field constant (unsaturated)
Läuferträgheitsmoment I .....	0.40 kg-m <sup>2</sup> .....	Moment of Inertia
Läuferschwingmoment GD <sup>2</sup> .....	1.6 kg-m <sup>2</sup> .....	Flywheel Effect GD <sup>2</sup>
Maschinengewicht .....	363 kg .....	Motor Weight
Fremdlüfter: Fördermenge .....	11 m <sup>3</sup> /min .....	Blower: Air Volume
Motordaten für 380 V, 50 Hz .....	0.56 kW / 1.2 A .....	Motor data for 380 V, 50 Hz

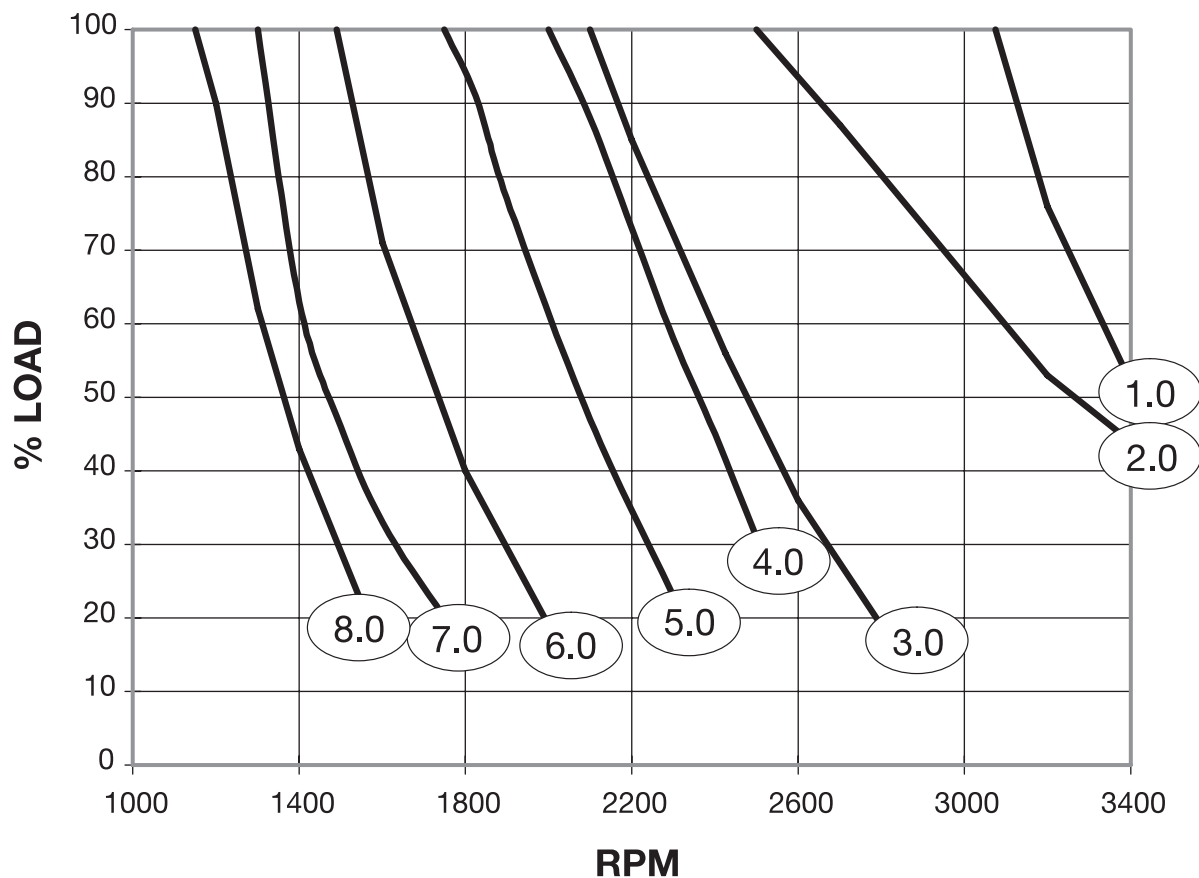

Leistungsreduktion bei Feldschwächung ..... maximal zulässige Drehzahl n = 3400 U / min  
Reduction of listed rating at Field Weakening ..... maximum safe speed n = 3400 RPM

## Rating Sheets and Derate Curves

Vollgeblechter Gleichstrom – Nebenschlußmotor  
fremdgekühlt  
Laminated DC – Motor with Shunt Field  
force – ventilated  
TYPE : GK1610

Ankerkreis Armature	Nennzahl (U/min) bei Ankerspannung Base speed (RPM) at armature voltage				Feld- steuerg Field Control U/min RPM	Nenn- leistung Nominal Rating kW	Nenn- Strom Nominal Current Amps	Wirkungs- grad Efficiency %	Ankerkreis / Armature		
	400	460	520	600					Widerstand Resistance warm Ohms	Induktivität Inductance mH	Zeit- Konstante Time- Constant ms
1.0	1720	2000	2275	2645	3000	71.9	200	87	0.13	2.5	19.2
					3050	81.4	195	88			
					3100	89.8	189	89			
					3075	99.3	180	90			
2.0	1550	1805	—	—	2100	71.3	199	87	0.14	2.7	19.3
					2000	80.9	194	88			
					—	—	—	—			
					—	—	—	—			
3.0	1380	1605	1840	—	2200	65.1	184	87	0.18	3.6	20.0
					2100	74.6	181	87			
					2000	83.3	177	88			
					—	—	—	—			
4.0	1070	1250	1430	1670	2250	51.4	149	83	0.29	5.7	19.7
					2200	59.7	148	85			
					2150	66.6	144	86			
					2100	76.3	141	88			
5.0	860	1000	1150	1355	1900	40.6	123	79	0.48	8.1	16.9
					1900	47.4	122	81			
					1800	54.2	121	83			
					1750	62.2	118	85			
6.0	700	820	950	1120	1600	33.4	103	77	0.64	11	17.2
					1550	39.6	104	79			
					1500	45.4	103	81			
					1450	52.9	102	83			
7.0	595	705	815	965	1400	28.5	90	75	0.84	15	17.9
					1350	33.6	89.5	78			
					1300	39.4	91.5	79			
					1300	45.6	89.3	82			
8.0	510	610	710	835	1250	24.2	79.5	71	1.1	18	16.4
					1250	28.5	78	75			
					1200	33.3	78.5	78			
					1150	39.3	78.5	80			

## Rating Sheets and Derate Curves

Vollgeblechter Gleichstrom – Nebenschlußmotor  
fremdgekühlt  
Laminated DC – Motor with Shunt Field  
force – ventilated  
TYPE : GK1808

Schutzart	IP23	Enclosure
Erregerleistung	1800 W	Exciter Rating
Erregerzeitkonstante (ungesättigt)	375 ms	Exciter field constant (unsaturated)
Läuferträgheitsmoment I	0.47 kg-m <sup>2</sup>	Moment of Inertia
Läuferschwungmoment GD <sup>2</sup>	1.9 kg-m <sup>2</sup>	Flywheel Effect GD <sup>2</sup>
Maschinengewicht	424 kg	Motor Weight
Fremdlüfter: Fördermenge	15 m <sup>3</sup> /min	Blower: Air Volume
Motordaten für 380 V, 50 Hz	1.12 kW / 2.6 A	Motor data for 380 V, 50 Hz

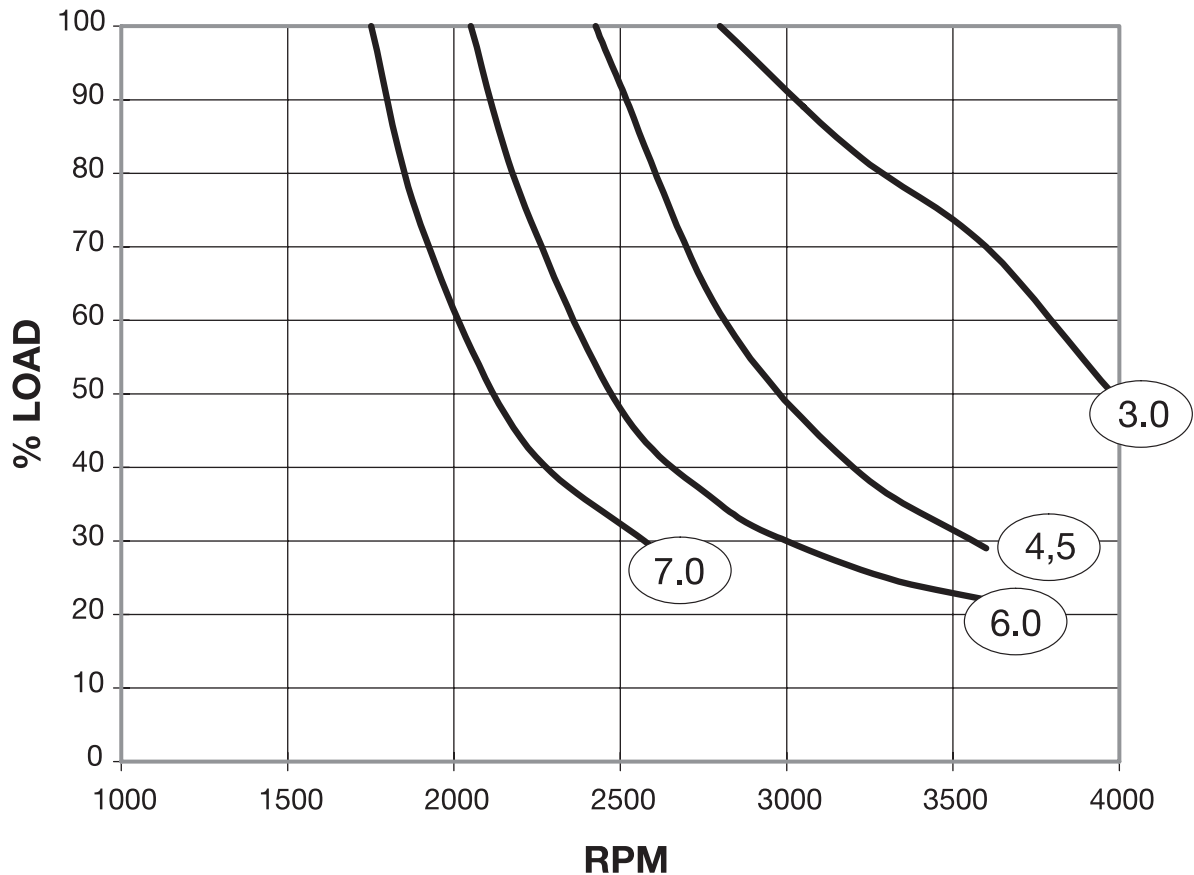

Leistungsreduktion bei Feldschwächung ..... maximal zulässige Drehzahl n = 4000 U / min  
Reduction of listed rating at Field Weakening ..... maximum safe speed n = 4000 RPM

## Rating Sheets and Derate Curves

Vollgeblechter Gleichstrom – Nebenschlußmotor  
fremdgekühlt  
Laminated DC – Motor with Shunt Field  
force – ventilated  
TYPE : GK1808

Ankerkreis Armature	Nennzahl (U/min) bei Ankerspannung Base speed (RPM) at armature voltage				Feld- steuerg Field Control U/min RPM	Nenn- leistung Nominal Rating kW	Nenn- Strom Nominal Current Amps	Wirkungs- grad Efficiency %	Ankerkreis / Armature		
	400	460	520	600					Widerstand Resistance warm Ohms	Induktivität Inductance mH	Zeit- Konstante Time- Constant ms
1.0	2335	2700	3060	—	3800	112	305	90	0.06	1.1	18.5
					3800	125	295	91			
					3800	137	285	91			
					—	—	—	—			
2.0	2000	2320	2635	3050	3800	98.5	270	89	0.08	1.36	16.8
					3800	113	267	90			
					3800	124	258	91			
					3800	136	244	91			
3.0	1770	2055	2340	2715	2800	86.2	240	88	0.12	2.15	18.5
					2800	99.3	238	89			
					2800	111	233	90			
					2800	124	224	90			
4.0	1385	1615	1845	2145	2475	69.6	196	86	0.17	2.9	17.2
					2475	80.9	196	87			
					2475	91.4	194	88			
					2475	103	188	89			
5.0	1140	1330	1520	1775	2450	60.8	174	85	0.23	4.2	18.3
					2450	70.6	173	86			
					2450	79.4	170	88			
					2425	91	167	89			
6.0	915	1075	1235	1445	2100	48.6	144	82	0.36	6.0	16.6
					2100	57	144	84			
					2100	65	143	85			
					2050	75.2	141	87			
7.0	770	905	1045	1225	1800	42	126	80	0.45	8.2	18.2
					1800	49.1	125	82			
					1800	56.4	125	84			
					1750	65.7	124	86			

## Rating Sheets and Derate Curves

Vollgeblechter Gleichstrom – Nebenschlußmotor  
fremdgekühlt  
Laminated DC – Motor with Shunt Field  
force – ventilated  
TYPE : GK1810

Schutzart .....	IP23 .....	Enclosure
Erregerleistung .....	2300 W .....	Exciter Rating
Erregerzeitkonstante (ungesättigt) .....	375 ms .....	Exciter field constant (unsaturated)
Läuferträgheitsmoment I .....	0.63 kg-m <sup>2</sup> .....	Moment of Inertia
Läuferschwingmoment GD <sup>2</sup> .....	2.5 kg-m <sup>2</sup> .....	Flywheel Effect GD <sup>2</sup>
Maschinengewicht .....	508 kg .....	Motor Weight
Fremdlüfter: Fördermenge .....	15 m <sup>3</sup> /min .....	Blower: Air Volume
Motordaten für 380 V, 50 Hz .....	1.12 kW / 2.6 A .....	Motor data for 380 V, 50 Hz

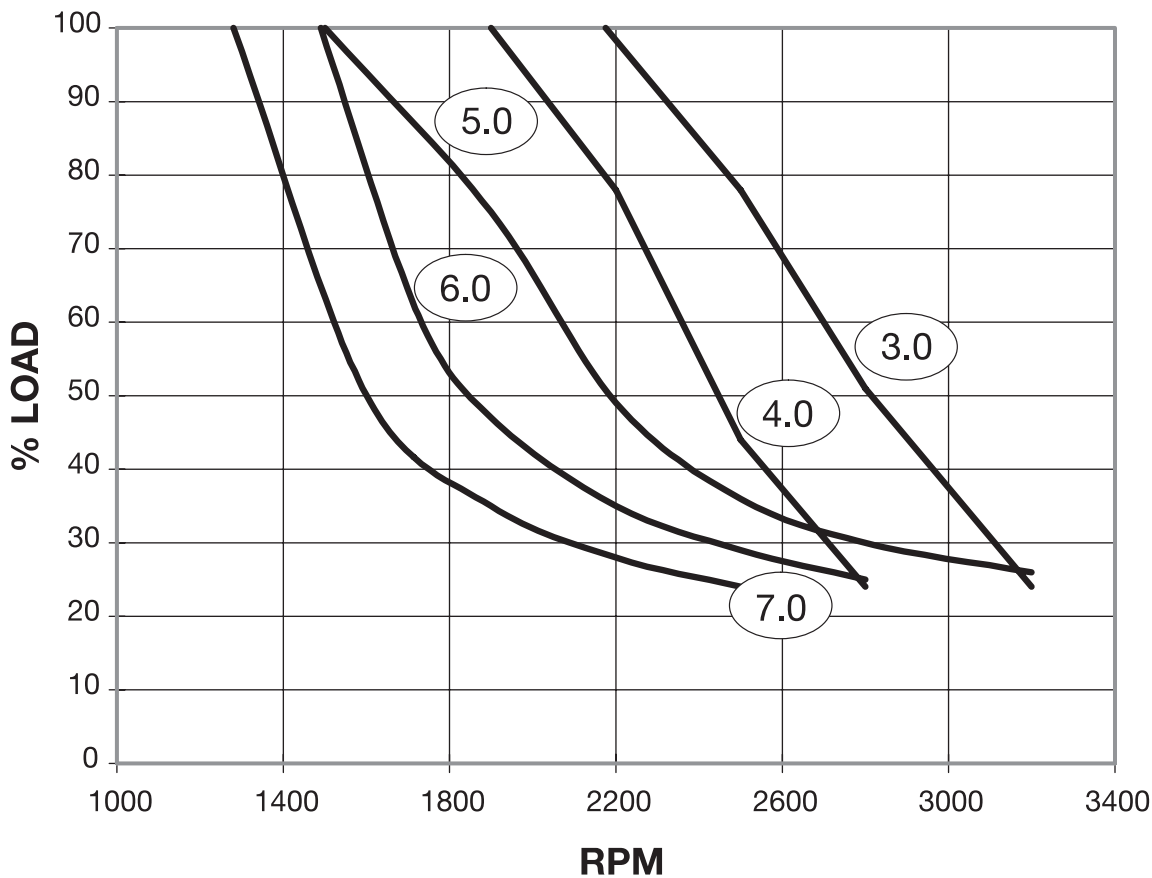

Leistungsreduktion bei Feldschwächung ..... maximal zulässige Drehzahl n = 3400 U / min  
Reduction of listed rating at Field Weakening ..... maximum safe speed n = 3400 RPM



## Rating Sheets and Derate Curves

Vollgeblechter Gleichstrom – Nebenschlußmotor  
fremdgekühlt  
Laminated DC – Motor with Shunt Field  
force – ventilated  
TYPE : GK1810

Ankerkreis Armature	Nennzahl (U/min) bei Ankerspannung Base speed (RPM) at armature voltage				Feld- steuerg Field Control U/min RPM	Nenn- leistung Nominal Rating kW	Nenn- Strom Nominal Current Amps	Wirkungs- grad Efficiency %	Ankerkreis / Armature		
	400	460	520	600					Widerstand Resistance warm Ohms	Induktivität Inductance mH	Zeit- Konstante Time- Constant ms
1.0	1645	1910	2165	2505	3400 3300 3250 3200	114 131 143 156	315 310 298 280	89 90 90 91	0.077	1.48	19.3
2.0	1390	1625	1850	2120	3000 3000 3000 3000	97 113 127 143	270 271 267 258	88 89 89 90	0.11	1.9	17.8
3.0	1185	1385	1580	1840	2200 2200 2200 2175	83.7 96.4 109.6 125	238 235 234 229	85 87 88 89	0.16	3	19.4
4.0	1030	1200	1375	1605	1950 1950 1925 1900	72.4 84.4 96.7 111	207 207 208 204	85 86 87 88	0.19	3.98	20.6
5.0	810	950	1085	1270	1650 1600 1550 1500	57.7 66.9 76.3 88.6	169 167 166 165	83 84 86 87	0.29	5.64	19.7
6.0	645	760	875	1030	1350 1350 1300 1250	45.2 53.8 61.3 71.6	138 140 138 137	79 81 83 85	0.46	8.27	18.1
7.0	540	645	740	875	1200 1150 1100 1050	38.2 45.4 52.3 61.1	118 119 119 118	77 80 82 84	0.57	11.2	19.5

## Rating Sheets and Derate Curves

Vollblechler Gleichstrom – Nebenschlußmotor  
fremdgekühlt  
Laminated DC – Motor with Shunt Field  
force – ventilated  
TYPE : GK2008 and LGK2008

Schutzart .....	IP23 .....	Enclosure
Erregerleistung .....	1900 W .....	Exciter Rating
Erregerzeitkonstante (ungesättigt) .....	500 ms .....	Exciter field constant (unsaturated)
Läuferträgheitsmoment I .....	1.1 kg-m <sup>2</sup> .....	Moment of Inertia
Läuferschwingmoment GD <sup>2</sup> .....	4.3 kg-m <sup>2</sup> .....	Flywheel Effect GD <sup>2</sup>
Maschinengewicht .....	665 kg .....	Motor Weight
Fremdlüfter: Fördermenge .....	20 m <sup>3</sup> /min .....	Blower: Air Volume
Motordaten für 380 V, 50 Hz .....	1.12 kW / 2.6 A .....	Motor data for 380 V, 50 Hz

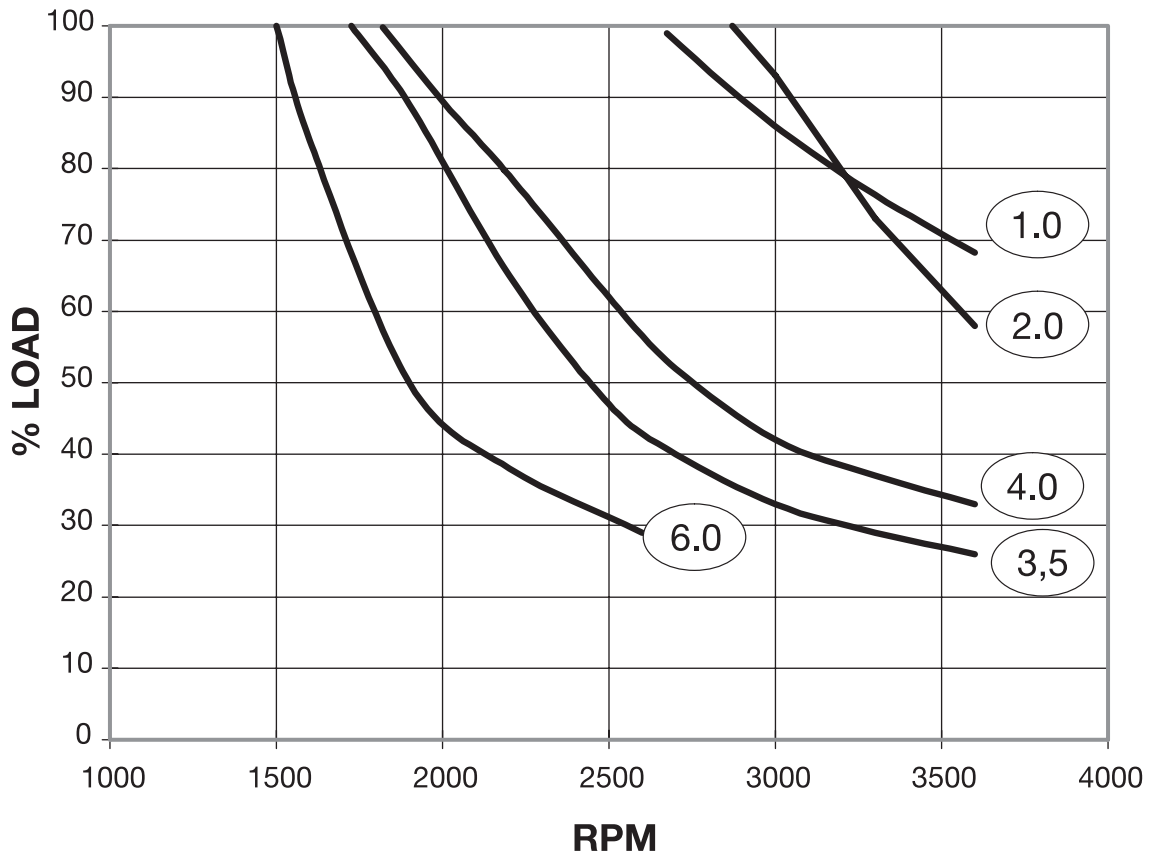

Leistungsreduktion bei Feldschwächung ..... maximal zulässige Drehzahl n = 3600 U / min  
Reduction of listed rating at Field Weakening ..... maximum safe speed n = 3600 RPM

## Rating Sheets and Derate Curves

Vollgeblechter Gleichstrom – Nebenschlußmotor  
fremdgekühlt  
Laminated DC – Motor with Shunt Field  
force – ventilated  
TYPE : GK2008 and LGK2008

Ankerkreis Armature	Nennzahl (U/min) bei Ankerspannung Base speed (RPM) at armature voltage				Feld- steuerg Field Control U/min RPM	Nenn- leistung Nominal Rating kW	Nenn- Strom Nominal Current Amps	Wirkungs- grad Efficiency %	Ankerkreis / Armature		
	400	460	520	600					Widerstand Resistance warm Ohms	Induktivität Inductance mH	Zeit- Konstante Time- Constant ms
1.0 LGK2008	1795	2075	2350	—	2600 2600 2600 —	155 177 197 —	420 415 405 —	91 92 92 —	0.044	1.28	29.9
2.0 GK2008	1380	1600	1820	2100	2875 2875 2875 2850	123 141 159 177	338 335 330 316	89 90 91 92	0.075	1.89	25.1
3.0 GK2008	1085	1265	1435	1670	1700 1700 1700 1700	99.3 115 128 147	278 278 270 266	87 89 90 91	0.12	3.29	27.9
4.0 GK2008	970	1130	1290	1500	1825 1800 1800 1750	88.3 103 116 133	250 260 247 243	86 88 89 90	0.15	3.9	26.0
5.0 GK2008	810	950	1085	1265	1725 1725 1725 1725	74.1 86.7 97.6 113	214 214 210 208	84 86 87 89	0.21	6.1	29.3
6.0 GK2008	600	710	815	955	1550 1550 1525 1500	58.9 68.7 78.6 91.3	177 175 174 172	80 83 84 86	0.33	9.1	27.6

**Note:** Armature 1 requires longer opposite drive end bracket (LGK2008 frame)

## Rating Sheets and Derate Curves

Vollblechler Gleichstrom – Nebenschlußmotor  
fremdgekühlt  
Laminated DC – Motor with Shunt Field  
force – ventilated  
TYPE : GK2010 and LGK2010

Schutzart .....	IP23 .....	Enclosure
Erregerleistung .....	2200 W .....	Exciter Rating
Erregerzeitkonstante (ungesättigt) .....	500 ms .....	Exciter field constant (unsaturated)
Läuferträgheitsmoment I .....	1.2 kg-m <sup>2</sup> .....	Moment of Inertia
Läuferschwingmoment GD <sup>2</sup> .....	4.9 kg-m <sup>2</sup> .....	Flywheel Effect GD <sup>2</sup>
Maschinengewicht .....	717 kg .....	Motor Weight
Fremdlüfter: Fördermenge .....	20 m <sup>3</sup> /min .....	Blower: Air Volume
Motordaten für 380 V, 50 Hz .....	1.12 kW / 2.6 A .....	Motor data for 380 V, 50 Hz

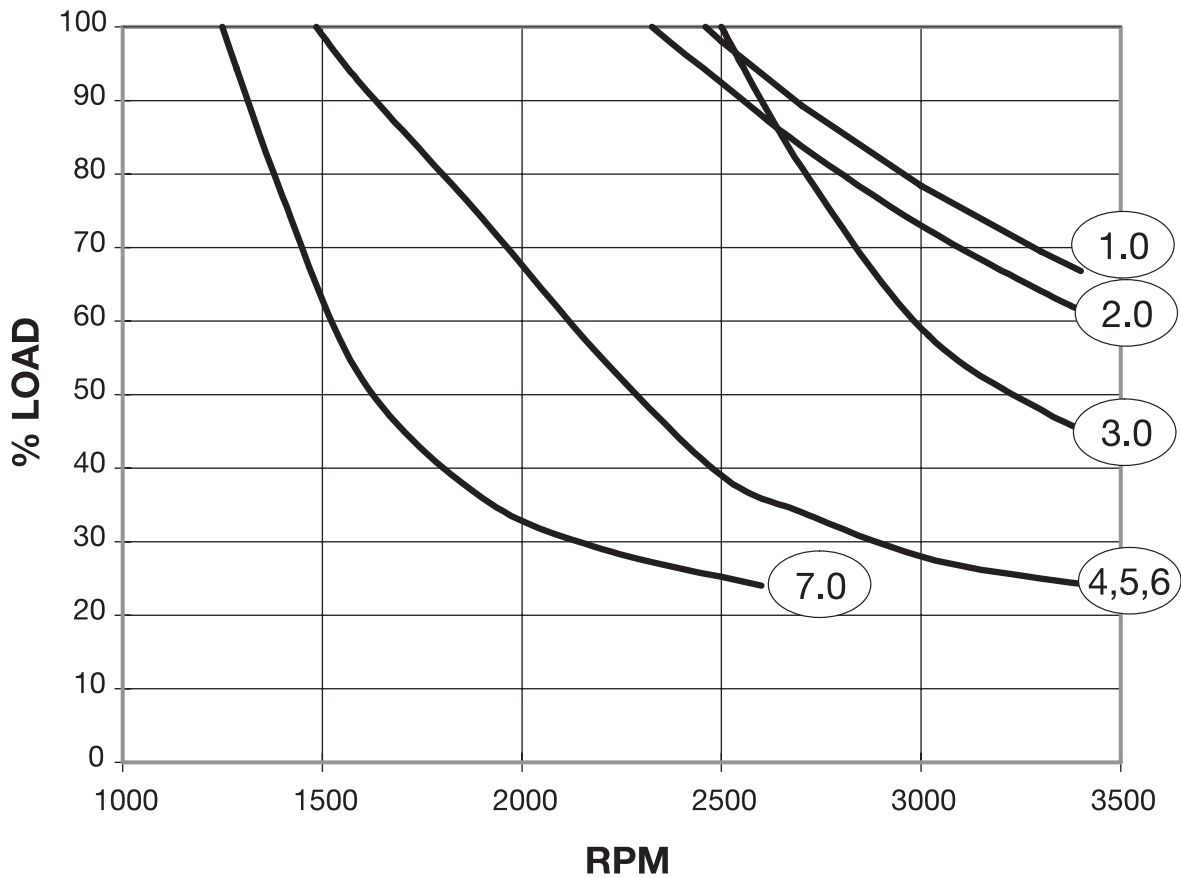

Leistungsreduktion bei Feldschwächung ..... maximal zulässige Drehzahl n = 3400 U / min  
Reduction of listed rating at Field Weakening ..... maximum safe speed n = 3400 RPM

## Rating Sheets and Derate Curves

Vollgeblechter Gleichstrom – Nebenschlußmotor  
fremdgekühlt  
Laminated DC – Motor with Shunt Field  
force – ventilated  
TYPE : GK2010 and LGK2010

Ankerkreis Armature	Nennzahl (U/min) bei Ankerspannung Base speed (RPM) at armature voltage				Feld- steuerg Field Control U/min RPM	Nenn- leistung Nominal Rating kW	Nenn- Strom Nominal Current Amps	Wirkungs- grad Efficiency %	Ankerkreis / Armature		
	400	460	520	600					Widerstand Resistance warm Ohms	Induktivität Inductance mH	Zeit- Konstante Time- Constant ms
1.0 LGK2010	1700	1965	2225	—	2450 2500 2500 —	169 192 213 —	460 451 440 —	90 91 92 —	0.042	1.22	28.9
2.0 LGK2010	1510	1750	1985	2295	2325 2325 2350 2325	157 181 202 226	427 425 417 403	90 91 92 92	0.050	1.48	29.8
3.0 GK2010	1155	1345	1530	1775	2550 2550 2500 2500	122 141 162 180	338 338 339 324	88 89 90 91	0.086	2.20	25.6
4.0 GK2010	920	1075	1225	1425	1525 1525 1525 1475	97.3 114 129 148	275 277 274 270	86 88 89 90	0.13	3.8	28.3
5.0 GK2010	820	960	1095	1255	1600 1550 1525 1475	87.2 102 116 134	250 252 250 247	85 86 88 89	0.17	4.5	26.3
6.0 GK2010	685	805	920	1080	1550 1500 1500 1500	72.1 85.6 98.5 114	211 215 216 213	83 84 86 87	0.24	7.1	29.0
7.0 GK2010	540	635	735	865	1350 1300 1300 1250	57.3 68.1 77.8 91.9	175 177 175 176	79 81 83 85	0.37	10.6	28.6

**Note:** Armatures 1, 2 require longer opposite drive end bracket (LGK2010 frame)

## Rating Sheets and Derate Curves

Vollgeblechter Gleichstrom – Nebenschlußmotor  
fremdgekühlt  
Laminated DC – Motor with Shunt Field  
force – ventilated  
TYPE : GK2208 and LGK2208

Schutzart .....	IP23 .....	Enclosure
Erregerleistung .....	3200 W .....	Exciter Rating
Erregerzeitkonstante (ungesättigt) .....	500 ms .....	Exciter field constant (unsaturated)
Läuferträgheitsmoment I .....	2.3 kg-m <sup>2</sup> .....	Moment of Inertia
Läuferschwingmoment GD <sup>2</sup> .....	9.1 kg-m <sup>2</sup> .....	Flywheel Effect GD <sup>2</sup>
Maschinengewicht .....	907 kg .....	Motor Weight
Fremdlüfter: Fördermenge .....	27 m <sup>3</sup> /min .....	Blower: Air Volume
Motordaten für 380 V, 50 Hz .....	1.87 kW / 3.8 A .....	Motor data for 380 V, 50 Hz

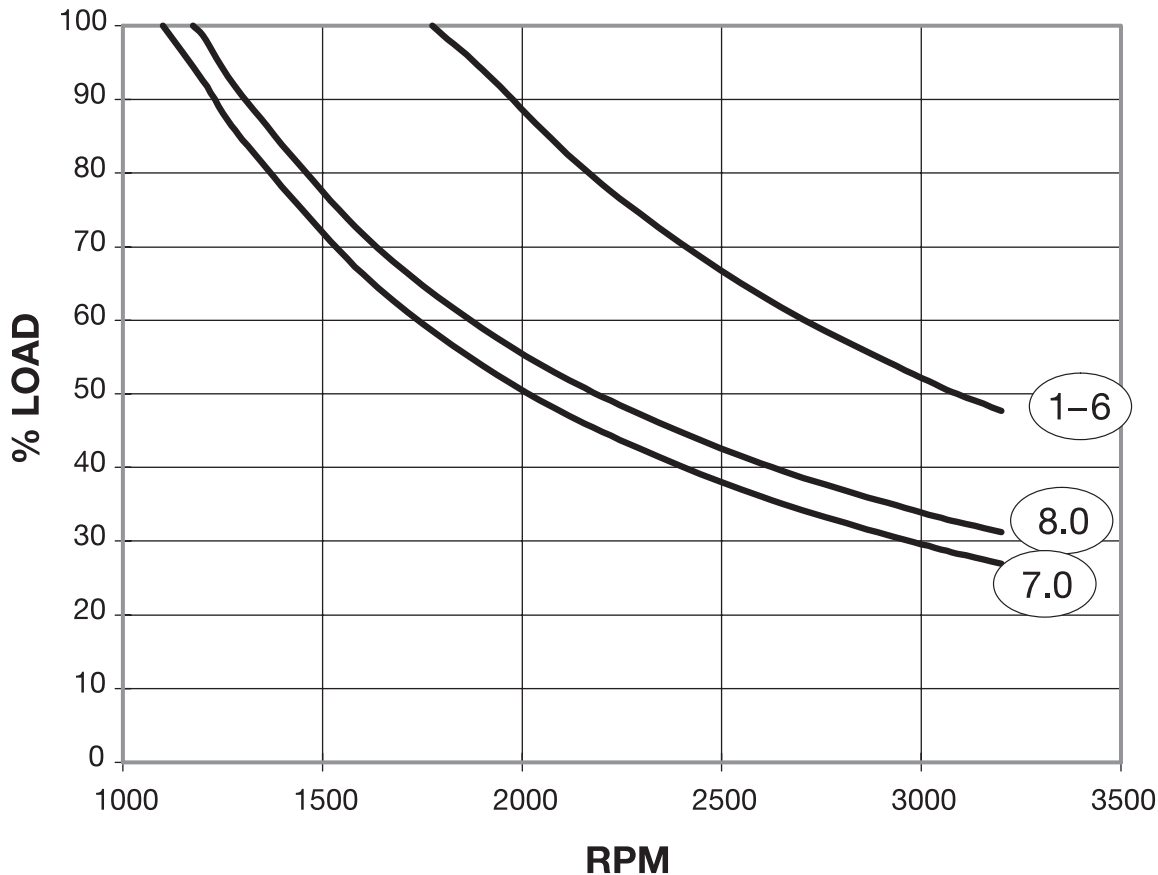

Leistungsreduktion bei Feldschwächung ..... maximal zulässige Drehzahl n = 3200 U / min  
Reduction of listed rating at Field Weakening ..... maximum safe speed n = 3200 RPM

## Rating Sheets and Derate Curves

Vollgeblechter Gleichstrom – Nebenschlußmotor  
fremdgekühlt  
Laminated DC – Motor with Shunt Field  
force – ventilated  
TYPE : GK2208 and LGK2208

Ankerkreis Armature	Nennzahl (U/min) bei Ankerspannung Base speed (RPM) at armature voltage				Feld- steuerg Field Control U/min RPM	Nenn- leistung Nominal Rating kW	Nenn- Strom Nominal Current Amps	Wirkungs- grad Efficiency %	Ankerkreis / Armature		
	400	460	520	600					Widerstand Resistance warm Ohms	Induktivität Inductance mH	Zeit- Konstante Time- Constant ms
1.0 LGK2208	1580	1825	—	—	1850 1850 — —	219 254 — —	592 592 — —	91 92 — —	0.029	0.75	26.0
2.0 LGK2208	1440	1670	—	—	1750 1750 — —	214 246 — —	580 575 — —	90 91 — —	0.034	0.92	27.2
3.0 LGK2208	1290	1490	1695	—	1775 1775 1775 —	194 222 249 —	528 522 515 —	90 91 92 —	0.041	1.1	27.7
4.0 LGK2208	1175	1365	1555	1800	1875 1875 1875 1875	175 201 226 255	480 475 470 455	89 90 91 92	0.051	1.4	26.5
5.0 LGK2208	1030	1195	1360	1580	1700 1700 1700 1700	157 181 204 232	434 430 425 416	88 89 90 91	0.064	1.8	27.5
6.0 GK2208	880	1025	1170	1365	1875 1875 1875 1875	138 160 180 206	388 385 380 372	87 88 89 90	0.086	2.2	25.2
7.0 GK2208	600	705	805	945	1125 1125 1125 1100	95.9 112 127 148	280 280 277 274	83 85 86 88	0.17	4.3	25.1
8.0 GK2208	480	565	650	765	1175 1175 1175 1175	76.1 89.3 102 119	229 228 227 225	80 82 84 86	0.25	7.0	27.4

**Note:** Armatures 1-5 require longer opposite drive end bracket (LGK2208 frame)

## Rating Sheets and Derate Curves

VollblechlerGleichstrom – Nebenschlußmotor  
fremdgekühlt  
Laminated DC – Motor with Shunt Field  
force – ventilated  
TYPE : GK2210 and LGK2210

Schutzart .....	IP23 .....	Enclosure
Erregerleistung .....	3400 W .....	Exciter Rating
Erregerzeitkonstante (ungesättigt) .....	500 ms .....	Exciter field constant (unsaturated)
Läuferträgheitsmoment I .....	2.5 kg-m <sup>2</sup> .....	Moment of Inertia
Läuferschwingmoment GD <sup>2</sup> .....	10 kg-m <sup>2</sup> .....	Flywheel Effect GD <sup>2</sup>
Maschinengewicht .....	957 kg .....	Motor Weight
Fremdlüfter: Fördermenge .....	27 m <sup>3</sup> /min .....	Blower: Air Volume
Motordaten für 380 V, 50 Hz .....	1.87 kW / 3.8 A .....	Motor data for 380 V, 50 Hz

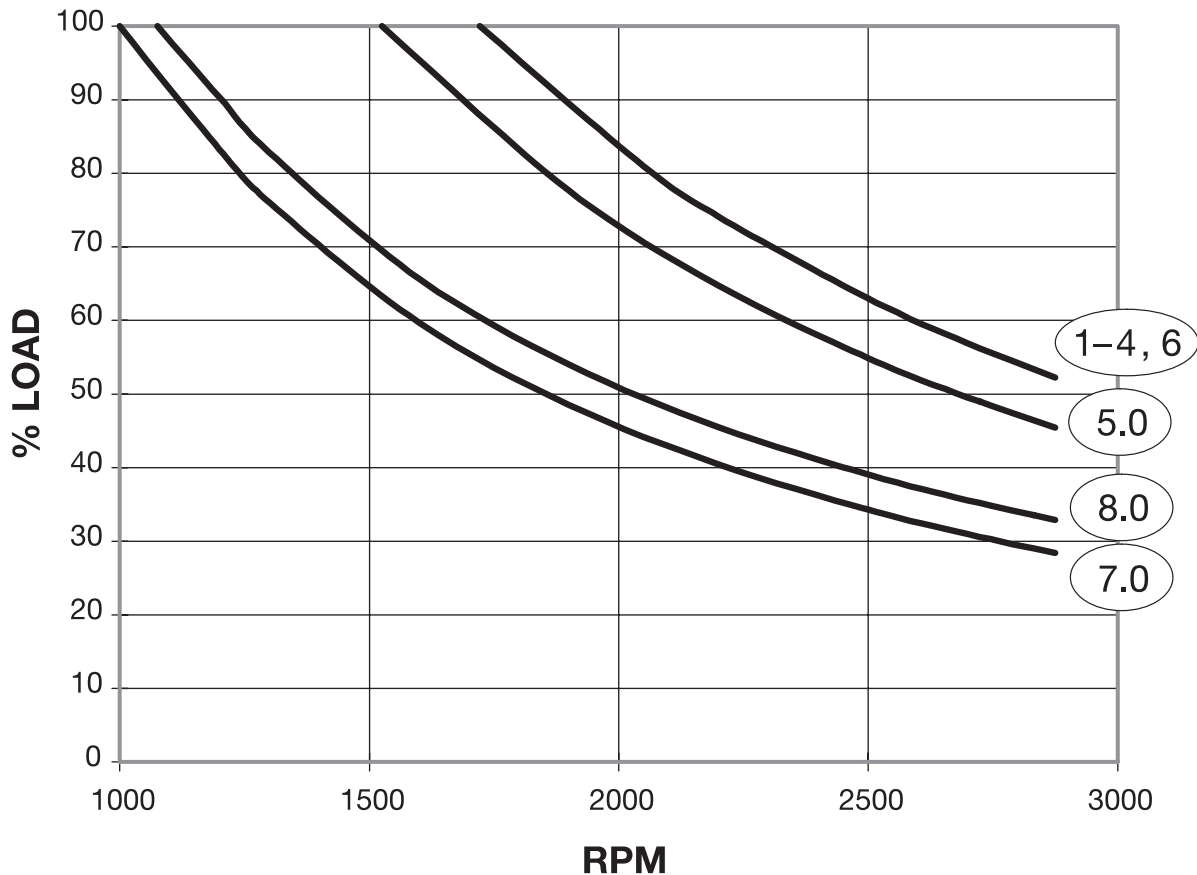

Leistungsreduktion bei Feldschwächung ..... maximal zulässige Drehzahl n = 2875 U / min  
Reduction of listed rating at Field Weakening ..... maximum safe speed n = 2875 RPM



## Rating Sheets and Derate Curves

Vollgeblechter Gleichstrom – Nebenschlußmotor  
fremdgekühlt  
Laminated DC – Motor with Shunt Field  
force – ventilated  
TYPE : GK GK2210 and LGK2210

Ankerkreis Armature	Nennzahl (U/min) bei Ankerspannung Base speed (RPM) at armature voltage				Feld- steuerg Field Control U/min RPM	Nenn- leistung Nominal Rating kW	Nenn- Strom Nominal Current Amps	Wirkungs- grad Efficiency %	Ankerkreis / Armature		
	400	460	520	600					Widerstand Resistance warm Ohms	Induktivität Inductance mH	Zeit- Konstante Time- Constant ms
1.0 LGK2210	1405	1625	—	—	1750 1750 — —	212 246 — —	574 574 — —	91 92 — —	0.031	0.836	26.6
2.0 LGK2210	1285	1490	—	—	1600 1650 — —	215 249 — —	585 585 — —	90 91 — —	0.037	1.03	27.8
3.0 LGK2210	1150	1335	1515	—	1600 1600 1600 —	195 226 251 —	535 533 520 —	89 90 91 —	0.045	1.3	28.4
4.0 LGK2210	1040	1210	1375	1595	1700 1700 1700 1700	176 204 228 257	485 485 475 460	88 90 91 91	0.056	1.5	26.8
5.0 LGK2210	900	1050	1195	1390	1525 1525 1525 1525	158 182 205 234	440 437 431 422	87 89 90 91	0.070	2.0	28.1
6.0 GK2210	780	915	1045	1215	1700 1700 1700 1700	138 161 180 207	390 390 383 376	86 87 89 90	0.094	2.4	25.7
7.0 GK2210	535	625	720	845	1000 1000 1000 1000	95.3 111 127 148	282 280 278 275	82 84 85 87	0.19	4.8	25.7
8.0 GK2210	420	495	570	670	1075 1075 1075 1075	74.9 88.4 100 116	229 229 225 222	78 81 83 85	0.28	7.8	28.1

**Note:** Armatures 1-5 require longer opposite drive end bracket (LGK2210 frame)

## Rating Sheets and Derate Curves

Vollgeblechter Gleichstrom – Nebenschlußmotor fremdgekühlt  
Laminated DC – Motor with Shunt Field  
force – ventilated  
TYPE : GK2508

Schutzart .....	IP23 .....	Enclosure
Erregerleistung .....	3000 W .....	Exciter Rating
Erregerzeitkonstante (ungesättigt) .....	650 ms .....	Exciter field constant (unsaturated)
Läuferträgheitsmoment I .....	3.4 kg-m <sup>2</sup> .....	Moment of Inertia
Läuferschwingmoment GD <sup>2</sup> .....	14 kg-m <sup>2</sup> .....	Flywheel Effect GD <sup>2</sup>
Maschinengewicht .....	1270 kg .....	Motor Weight
Fremdlüfter: Fördermenge .....	34 m <sup>3</sup> /min .....	Blower: Air Volume
Motordaten für 380 V, 50 Hz .....	1.87 kW / 3.8 A .....	Motor data for 380 V, 50 Hz

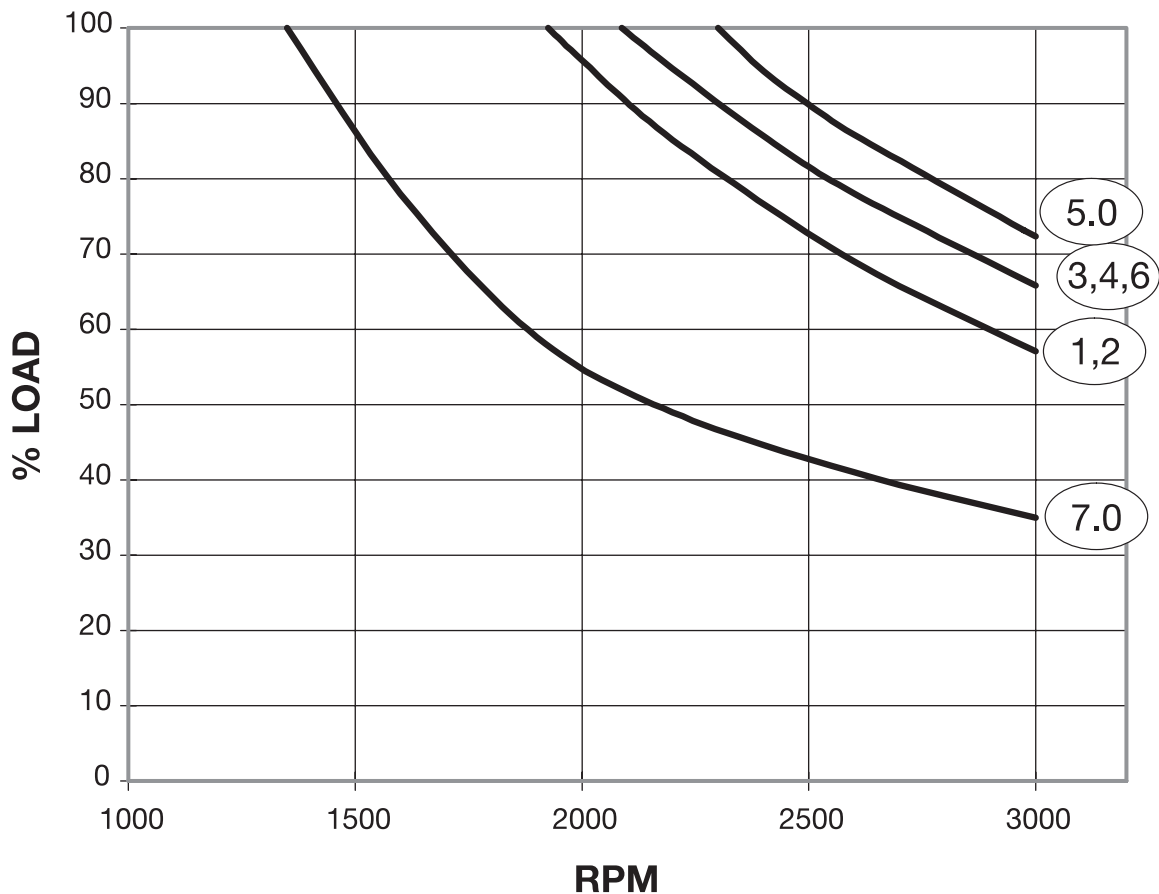

Leistungsreduktion bei Feldschwächung ..... maximal zulässige Drehzahl n = 3000 U / min  
Reduction of listed rating at Field Weakening ..... maximum safe speed n = 3000 RPM

## Rating Sheets and Derate Curves

Vollgeblechter Gleichstrom – Nebenschlußmotor  
fremdgekühlt  
Laminated DC – Motor with Shunt Field  
force – ventilated  
TYPE : GK2508

Ankerkreis Armature	Nennzahl (U/min) bei Ankerspannung Base speed (RPM) at armature voltage				Feld- steuerg Field Control U/min RPM	Nenn- leistung Nominal Rating kW	Nenn- Strom Nominal Current Amps	Wirkungs- grad Efficiency %	Ankerkreis / Armature		
	400	460	520	600					Widerstand Resistance warm Ohms	Inductivität Inductance mH	Zeit- Konstante Time- Constant ms
1.0	1435	1660	—	—	1950	250	674	91	0.028	0.82	29.6
					1950	292	680	92			
					—	—	—	—			
					—	—	—	—			
2.0	1140	1325	1515	1760	2000	198	539	90	0.042	1.3	31.0
					2000	230	540	91			
					2000	259	535	92			
					1900	295	524	92			
3.0	1040	1205	1375	1605	2150	176	483	89	0.052	1.6	30.8
					2150	205	485	90			
					2150	232	481	91			
					2125	265	472	92			
4.0	900	1045	1190	1385	2100	156	430	89	0.065	2.0	31.0
					2100	181	431	90			
					2100	205	428	91			
					2100	236	422	92			
5.0	800	935	1065	1240	2300	140	393	87	0.086	2.4	27.9
					2300	164	395	89			
					2300	186	392	90			
					2275	214	388	91			
6.0	655	765	875	1020	2100	114.7	327	86	0.12	3.3	26.8
					2100	134	327	87			
					2100	153	326	88			
					2075	177	324	90			
7.0	595	695	795	930	1350	101.6	291	85	0.14	3.9	27.1
					1350	119	292	87			
					1350	136	291	88			
					1350	157	289	89			

## Rating Sheets and Derate Curves

Vollgeblechter Gleichstrom – Nebenschlußmotor  
fremdgekühlt  
Laminated DC – Motor with Shunt Field  
force – ventilated  
TYPE : GK2510

Schutzart .....	IP23 .....	Enclosure
Erregerleistung .....	3400 W .....	Exciter Rating
Erregerzeitkonstante (ungesättigt) .....	750 ms .....	Exciter field constant (unsaturated)
Läuferträgheitsmoment I .....	4.2 kg-m <sup>2</sup> .....	Moment of Inertia
Läuferschwingmoment GD <sup>2</sup> .....	17 kg-m <sup>2</sup> .....	Flywheel Effect GD <sup>2</sup>
Maschinengewicht .....	1480 kg .....	Motor Weight
Fremdlüfter: Fördermenge .....	.34 m <sup>3</sup> /min .....	Blower: Air Volume
Motordaten für 380 V, 50 Hz .....	1.87 kW / 3.8 A .....	Motor data for 380 V, 50 Hz

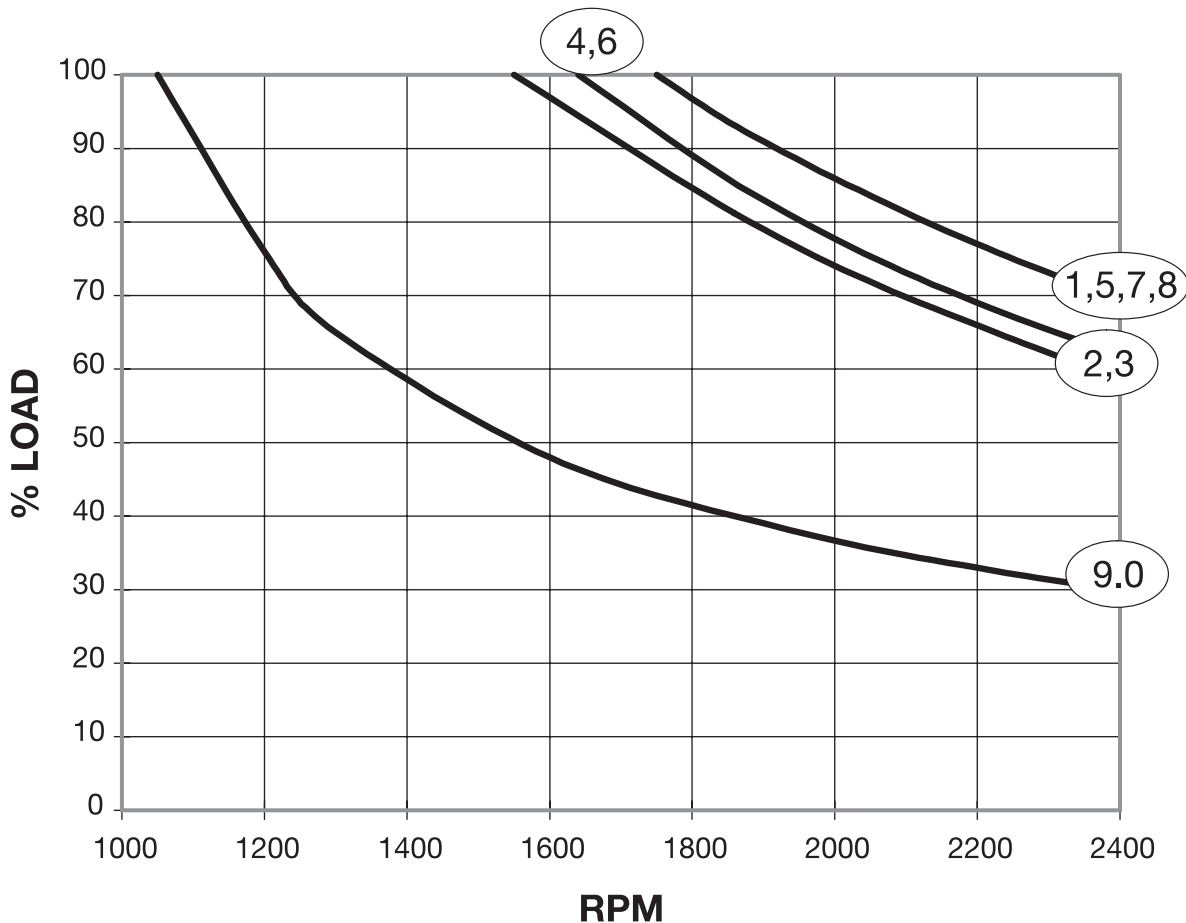

Leistungsreduktion bei Feldschwächung ..... maximal zulässige Drehzahl n = 2350 U / min  
Reduction of listed rating at Field Weakening ..... maximum safe speed n = 2350 RPM

## Rating Sheets and Derate Curves

Vollgeblechter Gleichstrom – Nebenschlußmotor  
 fremdgekühlt  
 Laminated DC – Motor with Shunt Field  
 force – ventilated  
 TYPE : GK2510

Ankerkreis Armature	Nenn-drehzahl (U/min) bei Ankerspannung Base speed (RPM) at armature voltage				Feld- steuerg Field Control U/min RPM	Nenn- leistung Nominal Rating kW	Nenn- Strom Nominal Current Amps	Wirkungs- grad Efficiency %	Ankerkreis / Armature		
	400	460	520	600					Widerstand Resistance warm Ohms	Inductivität Inductance mH	Zeit- Konstante Time- Constant ms
1.0	1415	1640	—	—	1800	321	860	92	0.018	0.73	39.7
					1800	371	860	93			
					—	—	—	—			
					—	—	—	—			
2.0	1215	1405	—	—	1550	289	778	91	0.023	0.75	32.9
					1550	335	778	92			
					—	—	—	—			
					—	—	—	—			
3.0	1010	1170	1330	—	1575	250	680	90	0.034	1.1	31.9
					1575	290	680	91			
					1550	327	675	92			
					—	—	—	—			
4.0	805	940	1070	1240	1625	196	540	89	0.052	1.7	33.4
					1625	228	540	90			
					1625	257	536	91			
					1625	296	530	92			
5.0	735	855	975	1135	1750	174	483	88	0.064	2.1	32.0
					1750	202	483	89			
					1750	229	481	90			
					1750	264	475	91			
6.0	635	735	840	980	1750	153	428	87	0.079	2.7	34.3
					1750	178	428	88			
					1750	202	426	89			
					1700	234	423	91			
7.0	565	660	750	880	1850	135	385	86	0.10	3.2	30.6
					1850	158	385	87			
					1850	181	385	88			
					1850	211	385	90			
8.0	460	535	615	720	1700	111	325	83	0.15	4.3	29.0
					1700	131	325	85			
					1700	150	325	87			
					1700	174	322	88			
9.0	415	485	560	655	1050	98	288	82	0.18	5.2	29.1
					1050	115	288	84			
					1050	132	288	86			
					1050	155	288	87			

## Rating Sheets and Derate Curves

Vollgeblechter Gleichstrom – Nebenschlußmotor  
fremdgekühlt  
Laminated DC – Motor with Shunt Field  
force – ventilated  
TYPE : GK2808

Schutzart .....	IP23 .....	Enclosure .....
Erregerleistung .....	3178 W .....	Exciter Rating .....
Erregerzeitkonstante (ungesättigt) .....	561 ms .....	Exciter field constant (unsaturated) .....
Läuferträgheitsmoment I .....	6.0 kg-m <sup>2</sup> .....	Moment of Inertia .....
Läuferschwungmoment GD <sup>2</sup> .....	24 kg-m <sup>2</sup> .....	Flywheel Effect GD <sup>2</sup> .....
Maschinengewicht .....	1600 kg .....	Motor Weight .....
Fremdlüfter: Fördermenge .....	55.5 m <sup>3</sup> /min .....	Blower: Air Volume .....
Motordaten für 380 V, 50 Hz .....	3.13 kW / 6.0 A .....	Motor data for 380 V, 50 Hz .....

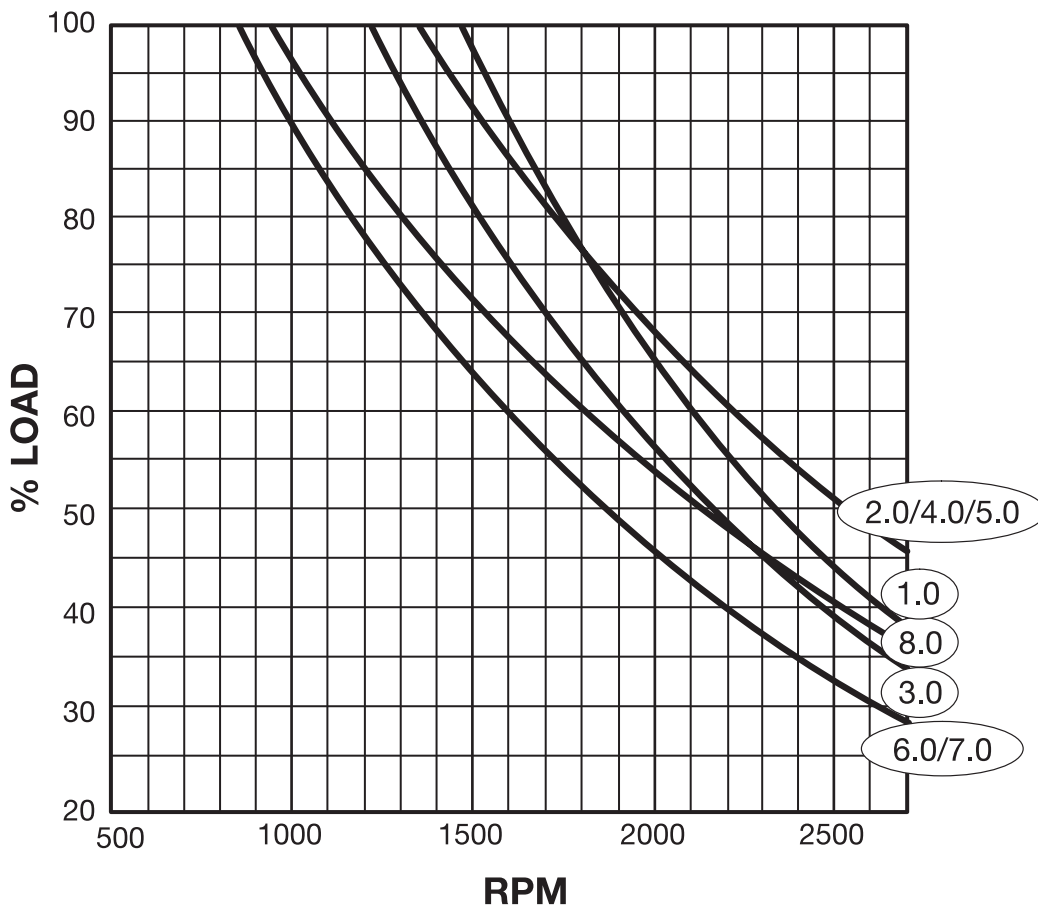

Armatures 1.0 – 8.0  
Curves shown are calculated data points.

Leistungsreduktion bei Feldschwächung ..... maximal zulässige Drehzahl n = 2700 U / min  
Reduction of listed rating at Field Weakening ..... maximum safe speed n = 2700 RPM

## Rating Sheets and Derate Curves

Vollgeblechter Gleichstrom – Nebenschlußmotor  
fremdgekühlt  
Laminated DC – Motor with Shunt Field  
force – ventilated  
TYPE : GK2808

Ankerkreis Armature	Nenn-drehzahl (U/min) bei Ankerspannung Base speed (RPM) at armature voltage					Feld- steuerg Field Control U/min RPM	Nenn- leistung Nominal Rating kW	Nenn- Strom Nominal Current Amps	Wirkungs- grad Efficiency %	Ankerkreis / Armature		
	Curve Number	400	460	520	600					Widerstand Resistance warm Ohms	Inductivität Inductance mH	Zeit- Konstante Time- Constant ms
1.0	2802.116400	1250				1450	332	895	91.7	0.0187	0.7111	38.0
	2808.116460		1500			—	368	851	92.4			
	2808.116520			1640		—	404	830	92.9			
	—				—	—	—	—	—			
2.0	2808.138400	1050				1375	296	805	91.0	0.0245	1.07	43.7
	2808.138460		1210			1425	327	764	91.9			
	2808.138520			1380		1425	370	761	92.4			
	—				—	—	—	—	—			
3.0	2808.162400	870				1200	244	667	90.1	0.034	1.43	41.9
	2808.162460		1000			1200	280	659	91.1			
	2808.162520			1140		1200	320	661	91.8			
	2808.162600				1330	—	360	640	92.5			
4.0	2808.184400	760				1350	207	572	88.9	0.047	1.8	38.3
	2808.184460		880			1350	244	581	89.9			
	2808.184520			1000		1350	280	585	90.7			
	2808.184600				1160	1350	325	583	91.6			
5.0	2808.216400	630				1300	177	494	87.7	0.062	2.5	39.8
	2808.216460		730			1300	208	500	89.0			
	2808.216520			840		1300	239	502	89.9			
	2808.216600				980	1300	276	497	90.9			
6.0	2808.138400	490				900	140	400	85.8	0.0936	3.92	41.9
	2808.135460		580			900	161	392	87.4			
	2808.135520			660		900	187	399	88.6			
	—				—	—	—	—	—			
7.0	2808.171400	390				875	104	295	85.0	0.1267	4.722	37.3
	2808.171460		450			875	125	304	86.5			
	2808.171520			520		875	140	299	88.0			
	2808.171600				600	875	168	308	89.3			
8.0	—	—				—	—	—	—	0.234	9.26	39.6
	2808.215460		350			950	94	241	81.9			
	2808.215520			410		950	109	244	83.5			
	2808.215600				470	950	130	248	87.9			

## Rating Sheets and Derate Curves

Vollgeblechter Gleichstrom – Nebenschlußmotor  
fremdgekühlt  
Laminated DC – Motor with Shunt Field  
force – ventilated  
TYPE : GK2810

Schutzart .....	IP23 .....	Enclosure
Erregerleistung .....	3800 W .....	Exciter Rating
Erregerzeitkonstante (ungesättigt) .....	570 ms .....	Exciter field constant (unsaturated)
Läuferträgheitsmoment I .....	7.5 kg-m <sup>2</sup> .....	Moment of Inertia
Läuferschwungmoment GD <sup>2</sup> .....	30 kg-m <sup>2</sup> .....	Flywheel Effect GD <sup>2</sup>
Maschinengewicht .....	1800 kg .....	Motor Weight
Fremdlüfter: Fördermenge .....	55.5 m <sup>3</sup> /min .....	Blower: Air Volume
Motordaten für 380 V, 50 Hz .....	3.13 kW / 6.0 A .....	Motor data for 380 V, 50 Hz

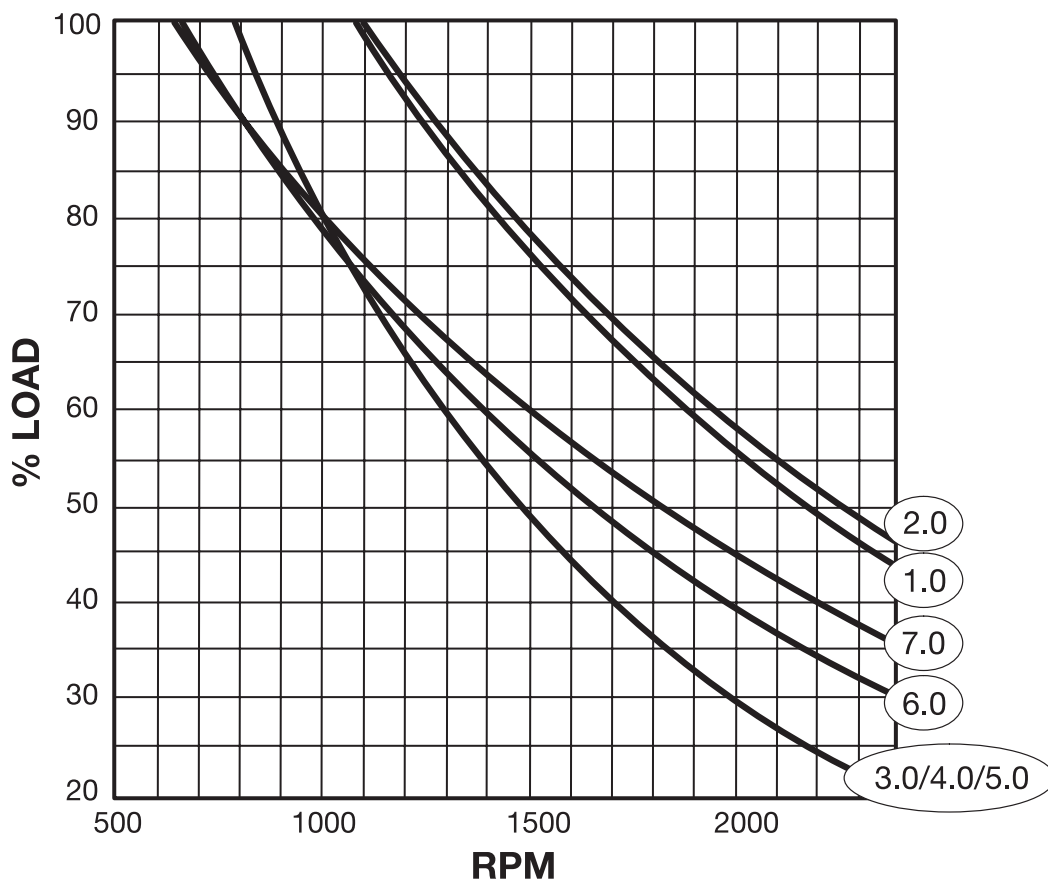

Armatures 1.0 – 7.0  
Curves shown are calculated data points.

Leistungsreduktion bei Feldschwächung ..... maximal zulässige Drehzahl n = 2400 U / min  
Reduction of listed rating at Field Weakening ..... maximum safe speed n = 2400 RPM



## Rating Sheets and Derate Curves

Vollgeblechter Gleichstrom – Nebenschlußmotor  
fremdgekühlt  
Laminated DC – Motor with Shunt Field  
force – ventilated  
TYPE : GK2810

Ankerkreis Armature	Nenn-drehzahl (U/min) bei Ankerspannung Base speed (RPM) at armature voltage				Feld- steuerg Field Control U/min RPM	Nenn- leistung Nominal Rating kW	Nenn- Strom Nominal Current Amps	Wirkungs- grad Efficiency %	Ankerkreis / Armature			
	Curve Number	400	460	520					600	Widerstand Resistance warm Ohms	Inductivität Inductance mH	Zeit- Konstante Time- Constant ms
1.0	2810.116400	995				1250	343	935	90.8	0.023	0.84	36.5
	2810.116460		1150			—	396	922	91.7			
	—			—		—	—	—	—			
	—				—	—	—	—	—			
2.0	2810.138400	835				1150	284	779	90.1	0.032	1.4	43.7
	2810.138460		965			1150	336	792	91.1			
	R3204A			1100		1150	393	817	91.7			
	—				—	—	—	—	—			
3.0	2810.162400	705				1000	245	677	89.2	0.041	1.7	41.5
	2810.162460		820			1000	284	675	90.5			
	2810.162520			935		1000	323	672	91.3			
	2810.162600				1085	—	376	674	92.1			
4.0	2810.184400	610				1050	215	604	87.3	0.057	2.2	38.6
	2810.184460		710			1050	252	609	88.6			
	2810.184520			810		1050	284	601	89.7			
	2810.184600				940	1050	334	607	90.7			
5.0	2810.216400	510				1050	178	506	86.5	0.073	3.0	41.1
	2810.216460		595			1050	207	502	88.0			
	2810.216520			680		1050	237	505	89.1			
	2810.216600				790	1050	276	503	90.2			
6.0	2810.135400	400				750	140	410	83.2	0.119	4.7	39.5
	2810.135460		470			750	165	413	85.0			
	2810.135520			540		750	189	412	86.5			
	—				—	—	—	—	—			
7.0	2810.171400	310				750	102	302	81.9	0.171	7.1	41.5
	2810.171460		365			700	131	338	82.1			
	2810.171520			420		700	139	306	85.2			
	2810.171600				490	700	162	303	87.0			

## Rating Sheets and Derate Curves

Vollgeblechter Gleichstrom – Nebenschlußmotor  
vollkommen geschlossen, unbelüftet  
Laminated DC – Motor with Shunt Field  
totally enclosed, non ventilated  
TYPE : GK1104

Schutzart .....	IP44 .....	Enclosure
Erregerleistung .....	150 W .....	Exciter Rating
Erregerzeitkonstante (ungesättigt) .....	175 ms .....	Exciter field constant (unsaturated)
Läuferträgheitsmoment I .....	0.029 kg-m <sup>2</sup> .....	Moment of Inertia
Läuferschwingmoment GD <sup>2</sup> .....	0.115 kg-m <sup>2</sup> .....	Flywheel Effect GD <sup>2</sup>
Maschinengewicht .....	84 kg .....	Motor Weight

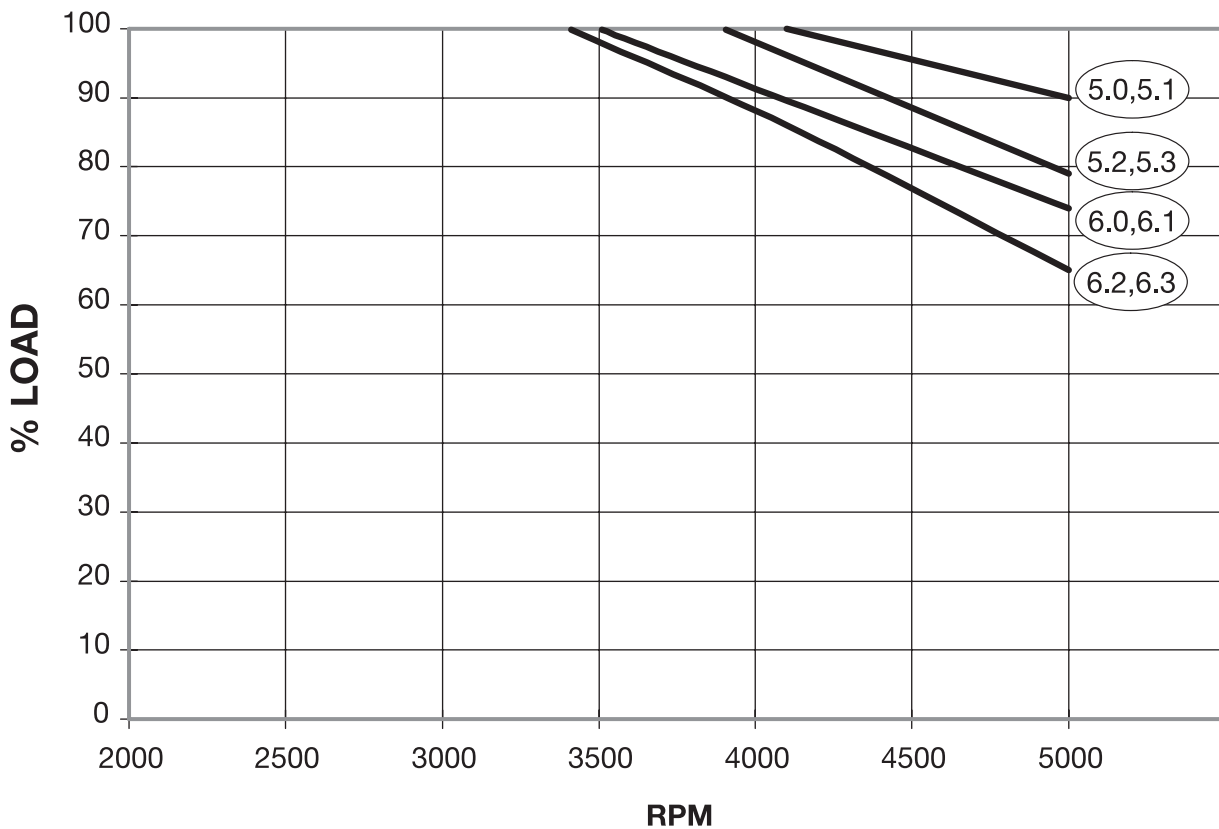

Leistungsreduktion bei Feldschwächung ..... maximal zulässige Drehzahl n = 5000 U / min  
Reduction of listed rating at Field Weakening ..... maximum safe speed n = 5000 RPM

## Rating Sheets and Derate Curves

Vollgeblechter Gleichstrom – Nebenschlußmotor  
vollkommen geschlossen, unbelüftet  
Laminated DC – Motor with Shunt Field  
totally enclosed, non ventilated  
TYPE : GK1104

Ankerkreis Armature	Nennzahl (U/min) bei Ankerspannung Base speed (RPM) at armature voltage				Feld- steuerg Field Control U/min RPM	Nenn- leistung Nominal Rating kW	Nenn- Strom Nominal Current Amps	Wirkungs- grad Efficiency %	Ankerkreis / Armature		
	260	300	400	460					Widerstand Resistance warm Ohms	Induktivität Inductance mH	Zeit- Konstante Time- Constant ms
1.0	2790	3225	—	—	5000 5000 — —	3.55 3.69 — —	15.5 13.9 — —	85 85 — —	0.80	9.0	11.3
2.0	2245	2610	—	—	5000 5000 — —	3.13 3.43 — —	13.8 13 — —	84 85 — —	1.26	14	11.1
3.0	1780	2080	2810	—	5000 5000 5000 —	2.56 2.9 3.4 —	11.4 11 9.6 —	82 84 85 —	1.8	19	10.6
4.0 4.1 4.2 4.3	1435	1685	2300	2665	5000 5000 4800 5000	2.11 2.42 3.05 3.33	9.6 9.4 8.7 8.2	80 81 84 85	2.7	28	10.4
5.0 5.1 5.2 5.3	1160	1365	1870	2170	4100 4100 3900 4000	1.79 2.08 2.71 3.02	8.3 8.2 7.8 7.5	78 80 83 84	3.9	42	10.8
6.0 6.1 6.2 6.3	975	1160	1600	1870	3500 3500 3400 3400	1.48 1.71 2.29 2.63	7.1 7 6.7 6.6	74 76 81 82	5.6	56	10.0

## Rating Sheets and Derate Curves

Vollgeblechter Gleichstrom – Nebenschlußmotor  
vollkommen geschlossen, unbelüftet  
Laminated DC – Motor with Shunt Field  
totally enclosed, non ventilated  
TYPE : GK1106

Schutzart .....	IP44 .....	Enclosure
Erregerleistung .....	150 W .....	Exciter Rating
Erregerzeitkonstante (ungesättigt) .....	150 ms .....	Exciter field constant (unsaturated)
Läuferträgheitsmoment I .....	0.033 kg-m <sup>2</sup> .....	Moment of Inertia
Läuferschwungmoment GD <sup>2</sup> .....	0.13 kg-m <sup>2</sup> .....	Flywheel Effect GD <sup>2</sup>
Maschinengewicht .....	93 kg .....	Motor Weight

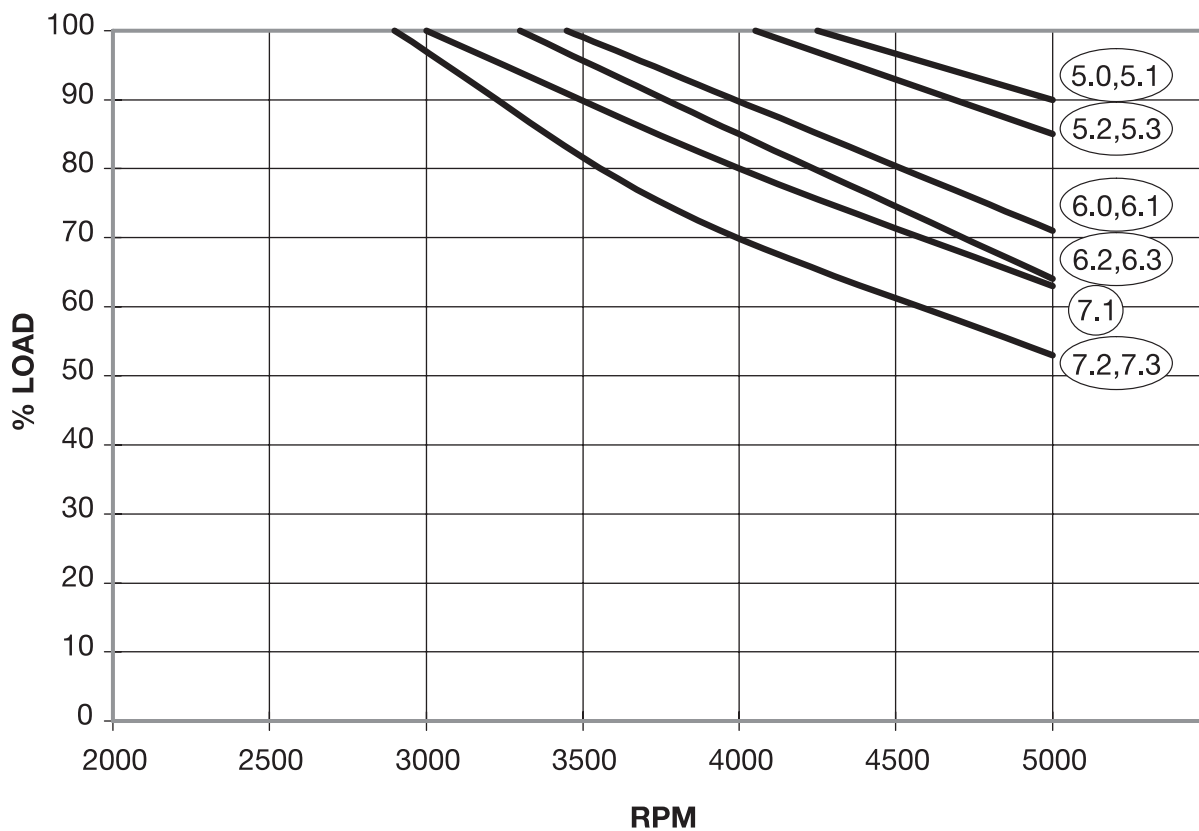

Leistungsreduktion bei Feldschwächung ..... maximal zulässige Drehzahl n = 5000 U / min  
Reduction of listed rating at Field Weakening ..... maximum safe speed n = 5000 RPM

## Rating Sheets and Derate Curves

Vollgeblechter Gleichstrom – Nebenschlußmotor  
vollkommen geschlossen, unbelüftet  
Laminated DC – Motor with Shunt Field  
totally enclosed, non ventilated  
TYPE : GK1106

Ankerkreis Armature	Nennzahl (U/min) bei Ankerspannung Base speed (RPM) at armature voltage				Feld- steuerung Field Control U/min RPM	Nenn- leistung Nominal Rating kW	Nenn- Strom Nominal Current Amps	Wirkungs- grad Efficiency %	Ankerkreis / Armature		
	260	300	400	460					Widerstand Resistance warm Ohms	Induktivität Inductance mH	Zeit- Konstante Time- Constant ms
1.0	2595	2985	—	—	5000	4.13	17.9	86	0.70	8.2	11.7
					5000	4.3	16.1	86			
					—	—	—	—			
					—	—	—	—			
2.0	2195	2550	—	—	5000	3.88	16.9	85	0.93	11	11.8
					5000	4.25	15.9	86			
					—	—	—	—			
					—	—	—	—			
3.0	1665	1945	2625	—	5000	3.08	13.6	83	1.4	17	12.1
					5000	3.46	13.1	84			
					5000	4.11	11.5	86			
					—	—	—	—			
4.0	1420	1660	2255	2610	5000	2.63	11.8	81	2.1	24	11.4
4.1					5000	3.02	11.6	83			
4.2					4800	3.8	10.7	85			
4.3					4800	4.11	10	86			
5.0	1140	1340	1835	2135	4250	2.14	9.9	78	3.2	34	10.6
5.1					4250	2.46	9.7	80			
5.2					4050	3.23	9.2	84			
5.3					4050	3.62	8.9	85			
6.0	910	1075	1490	1735	3450	1.79	8.5	76	4.5	51	11.3
6.1					3450	2.09	8.4	78			
6.2					3300	2.79	8.1	82			
6.3					3300	3.18	7.9	83			
7.0	—	885	1235	1445	—	—	—	—	6.5	71	10.9
7.1					3000	1.72	7.1	75			
7.2					2900	2.33	6.9	80			
7.3					2900	2.69	6.8	82			

## Rating Sheets and Derate Curves

Vollgeblechter Gleichstrom – Nebenschlußmotor  
vollkommen geschlossen, unbelüftet  
Laminated DC – Motor with Shunt Field  
totally enclosed, non ventilated  
TYPE : GK1108

Schutzart .....	IP44 .....	Enclosure
Erregerleistung .....	175 W .....	Exciter Rating
Erregerzeitkonstante (ungesättigt) .....	225 ms .....	Exciter field constant (unsaturated)
Läuferträgheitsmoment I .....	0.040 kg-m <sup>2</sup> .....	Moment of Inertia
Läuferschwingmoment GD <sup>2</sup> .....	0.16 kg-m <sup>2</sup> .....	Flywheel Effect GD <sup>2</sup>
Maschinengewicht .....	111 kg .....	Motor Weight

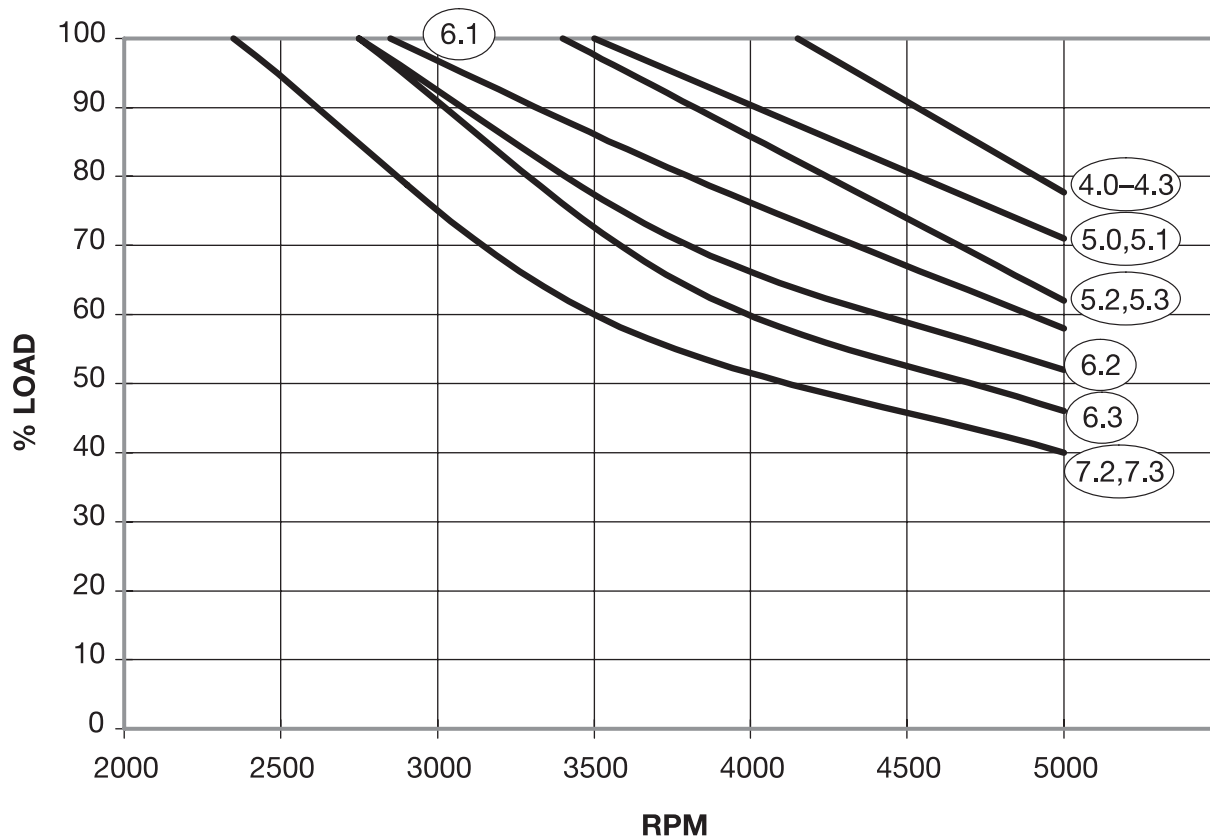

Leistungsreduktion bei Feldschwächung ..... maximal zulässige Drehzahl n = 5000 U / min  
Reduction of listed rating at Field Weakening ..... maximum safe speed n = 5000 RPM

## Rating Sheets and Derate Curves

Vollgeblechter Gleichstrom – Nebenschlußmotor  
 vollkommen geschlossen, unbelüftet  
 Laminated DC – Motor with Shunt Field  
 totally enclosed, non ventilated  
 TYPE : GK1108

Ankerkreis Armature	Nennzahl (U/min) bei Ankerspannung Base speed (RPM) at armature voltage				Feld- steuerung Field Control U/min RPM	Nenn- leistung Nominal Rating kW	Nenn- Strom Nominal Current Amps	Wirkungs- grad Efficiency %	Ankerkreis / Armature		
	260	300	400	460					Widerstand Resistance warm Ohms	Induktivität Inductance mH	Zeit- Konstante Time- Constant ms
1.0	2025	2340	—	—	5000	4.44	19.3	86	0.83	10	12.0
					5000	4.85	18.1	87			
					—	—	—	—			
					—	—	—	—			
2.0	1710	1990	2655	3055	5000	4.04	17.7	85	1.1	15	13.6
					5000	4.53	17	86			
					5000	5.34	14.8	87			
					5000	5.4	13	88			
3.0 3.1 3.2 3.3	1360	1590	2145	2480	4800	3.3	14.8	83	1.7	22	12.9
					4800	3.79	14.5	84			
					4700	4.75	13.3	87			
					4800	5.16	12.5	87			
4.0 4.1 4.2 4.3	1095	1290	1765	2050	4150	2.69	12.3	80	2.4	30	12.5
					4150	3.11	12.1	82			
					4000	4.03	11.4	85			
					4100	4.52	11	86			
5.0 5.1 5.2 5.3	875	1035	1430	1665	3500	2.16	10.2	76	3.7	44	11.9
					3500	2.52	10.1	79			
					3400	3.36	9.7	83			
					3400	3.8	9.4	84			
6.0 6.1 6.2 6.3	—	825	1155	1350	—	—	—	—	5.3	66	12.5
					2850	2.08	8.6	76			
					2750	2.85	8.4	81			
					2750	3.29	8.3	82			
7.0 7.1 7.2 7.3	—	—	950	1115	—	—	—	—	7.7	91	11.8
					—	—	—	—			
					2400	2.34	7.1	78			
					2350	2.72	7	80			

## Rating Sheets and Derate Curves

Vollgeblechter Gleichstrom – Nebenschlußmotor  
vollkommen geschlossen, unbelüftet  
Laminated DC – Motor with Shunt Field  
totally enclosed, non ventilated  
TYPE : GK1110

Schutzart .....	IP44 .....	Enclosure
Erregerleistung .....	150 W .....	Exciter Rating
Erregerzeitkonstante (ungesättigt) .....	300 ms .....	Exciter field constant (unsaturated)
Läuferträgheitsmoment I .....	0.043 kg-m <sup>2</sup> .....	Moment of Inertia
Läuferschwingmoment GD <sup>2</sup> .....	0.17 kg-m <sup>2</sup> .....	Flywheel Effect GD <sup>2</sup>
Maschinengewicht .....	120 kg .....	Motor Weight

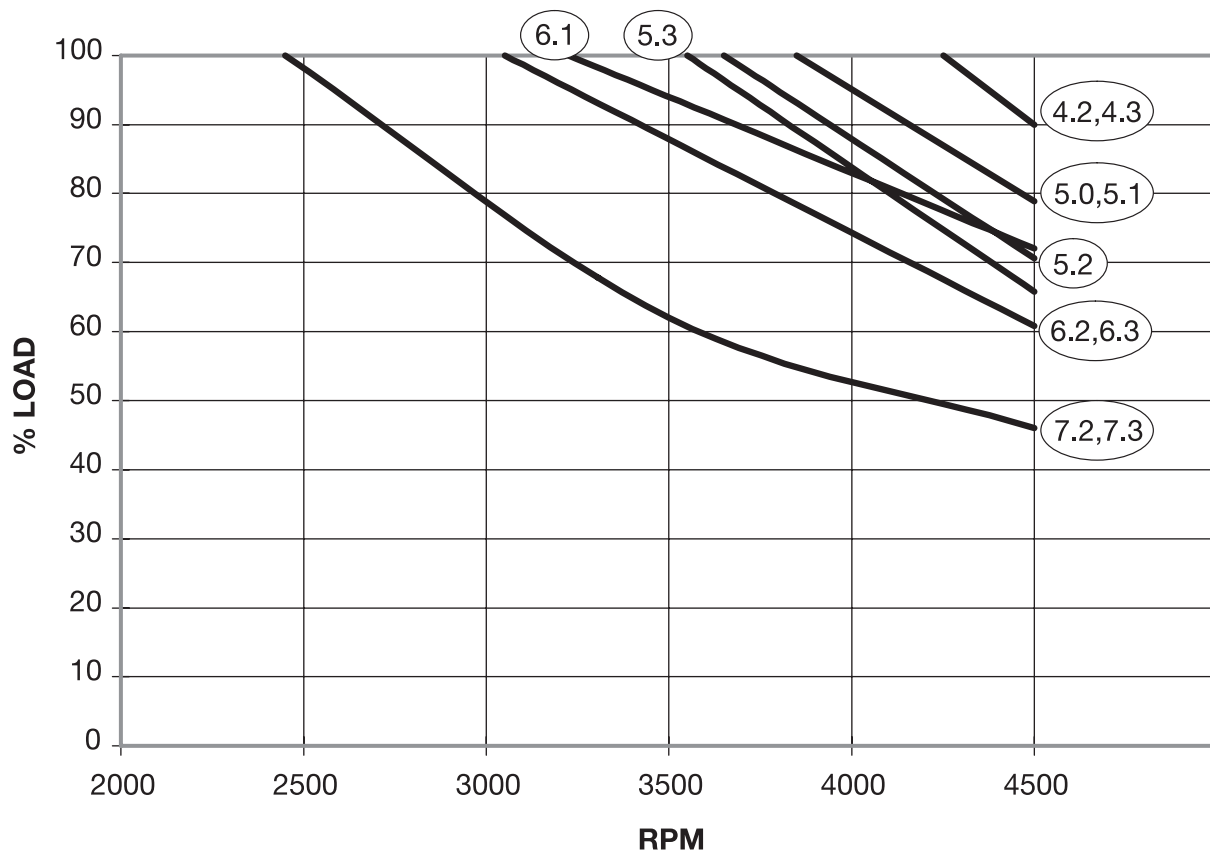

Leistungsreduktion bei Feldschwächung ..... maximal zulässige Drehzahl n = 4500 U / min  
Reduction of listed rating at Field Weakening ..... maximum safe speed n = 4500 RPM



## Rating Sheets and Derate Curves

Vollgeblechter Gleichstrom – Nebenschlußmotor  
vollkommen geschlossen, unbelüftet  
Laminated DC – Motor with Shunt Field  
totally enclosed, non ventilated  
TYPE : GK1110

Ankerkreis Armature	Nennzahl (U/min) bei Ankerspannung Base speed (RPM) at armature voltage				Feld- steuerg Field Control U/min RPM	Nenn- leistung Nominal Rating kW	Nenn- Strom Nominal Current Amps	Wirkungs- grad Efficiency %	Ankerkreis / Armature		
	260	300	400	460					Widerstand Resistance warm Ohms	Induktivität Inductance mH	Zeit- Konstante Time- Constant ms
1.0	2735	3155	—	—	4500 4500 — —	5.74 6 — —	24.6 22.2 — —	88 88 — —	0.45	6.1	13.6
2.0	1870	2175	2885	—	4500 4500 4500 —	4.55 5.08 5.73 —	19.9 19 15.9 —	85 87 88 —	0.89	12	13.5
3.0	1575	1835	2475	2825	4500 4500 4500 4500	4.08 4.66 5.65 6	18.1 17.6 15.7 14.4	84 86 88 88	1.2	16	13.3
4.0 4.1 4.2 4.3	1190	1385	1890	2190	4500 4500 4350 4250	3.26 3.75 4.78 5.25	14.7 14.4 13.4 12.7	82 83 86 87	1.8	25	13.9
5.0 5.1 5.2 5.3	970	1145	1570	1825	3900 3850 3650 3550	2.71 3.14 4.11 4.62	12.5 12.3 11.7 11.3	79 81 85 86	2.6	35	13.5
6.0 6.1 6.2 6.3	—	945	1310	1530	— 3225 3100 3050	— 2.52 3.4 3.9	— 10.2 9.9 9.7	— 78 82 84	4.1	49	12.0
7.0 7.1 7.2 7.3	—	—	1065	1240	— — 2500 2450	— — 2.89 3.31	— — 8.6 8.4	— — 80 82	5.8	73	12.6

## Rating Sheets and Derate Curves

Vollgeblechter Gleichstrom – Nebenschlußmotor  
vollkommen geschlossen, unbelüftet  
Laminated DC – Motor with Shunt Field  
totally enclosed, non ventilated  
TYPE : GK1303

Schutzart .....	IP44 .....	Enclosure
Erregerleistung .....	150 W .....	Exciter Rating
Erregerzeitkonstante (ungesättigt) .....	150 ms .....	Exciter field constant (unsaturated)
Läuferträgheitsmoment I .....	0.098 kg-m <sup>2</sup> .....	Moment of Inertia
Läuferschwingmoment GD <sup>2</sup> .....	0.39 kg-m <sup>2</sup> .....	Flywheel Effect GD <sup>2</sup>
Maschinengewicht .....	154 kg .....	Motor Weight

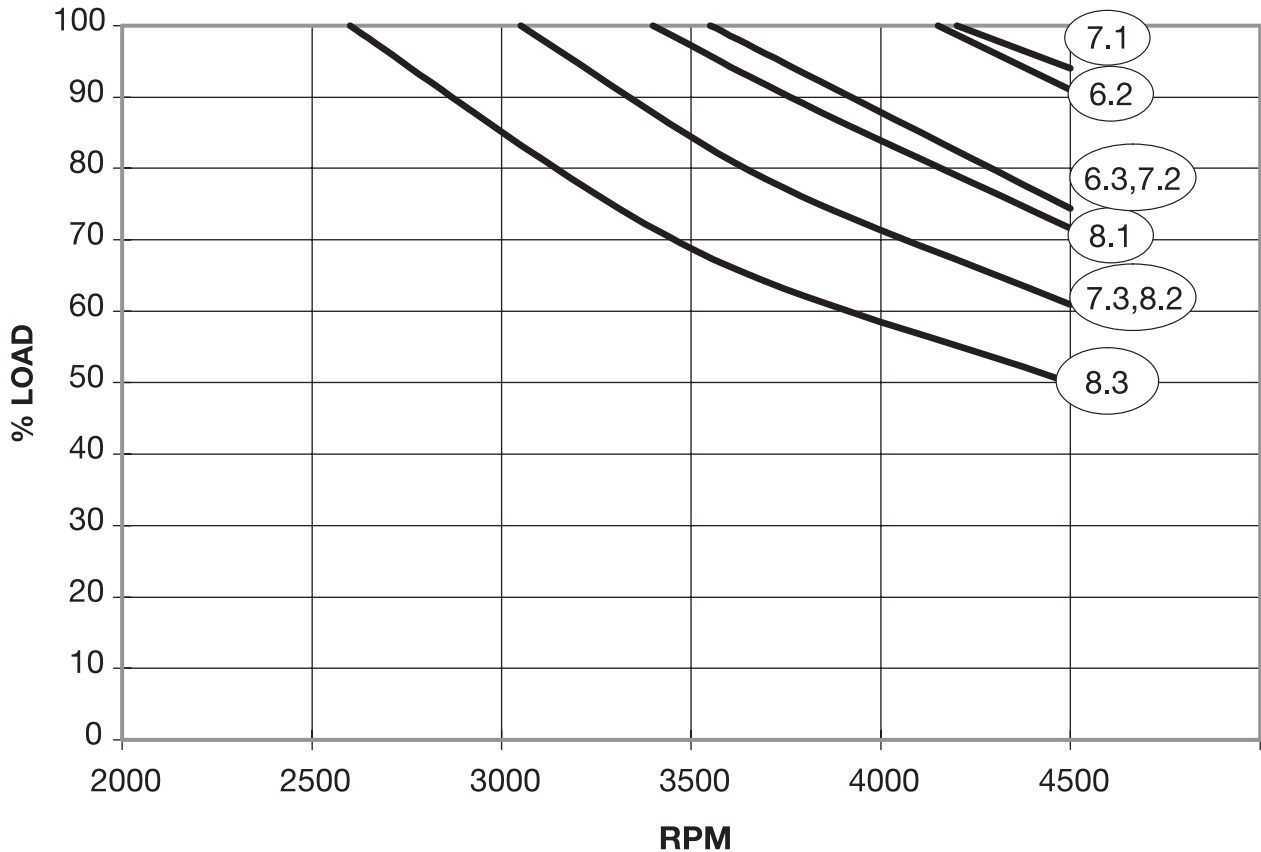

Leistungsreduktion bei Feldschwächung ..... maximal zulässige Drehzahl n = 4500 U / min  
Reduction of listed rating at Field Weakening ..... maximum safe speed n = 4500 RPM

## Rating Sheets and Derate Curves

Vollgeblechter Gleichstrom – Nebenschlußmotor  
vollkommen geschlossen, unbelüftet  
Laminated DC – Motor with Shunt Field  
totally enclosed, non ventilated  
TYPE : GK1303

Ankerkreis Armature	Nennzahl (U/min) bei Ankerspannung Base speed (RPM) at armature voltage				Feld- steuerung Field Control U/min RPM	Nenn- leistung Nominal Rating kW	Nenn- Strom Nominal Current Amps	Wirkungs- grad Efficiency %	Ankerkreis / Armature		
	260	300	400	460					Widerstand Resistance warm Ohms	Induktivität Inductance mH	Zeit- Konstante Time- Constant ms
1.0	2495	2915	—	—	4500	4.24	19.1	83	0.86	8.5	9.9
					4500	4.6	17.9	84			
		—			—	—	—				
		—			—	—	—				
2.0	2135	2490	—	—	4500	4.04	18.2	83	0.98	10	10.2
					4500	4.47	17.3	84			
		—			—	—	—				
		—			—	—	—				
3.0	1780	2100	2860	—	4500	3.39	15.5	82	1.4	14	10.0
					4500	3.87	15.2	83			
		4500			4.49	13	84				
		—			—	—	—				
4.0	1535	1795	2450	—	4500	3.21	14.7	81	1.6	16	10.0
					4500	3.64	14.3	82			
		4500			4.31	12.5	83				
		—			—	—	—				
5.0	1240	1470	2010	2335	4500	2.79	12.9	79	2.0	20	10.0
					4500	3.22	12.7	81			
		4500			4.0	11.6	83				
		4500			4.13	10.4	83				
6.0	975	1150	1595	1860	4500	2.23	10.6	76	3.1	31	10.0
6.1					4500	2.6	10.5	78			
6.2					4150	3.4	10	81			
6.3					3550	3.82	9.7	82			
7.0	835	990	1365	1610	4500	1.94	9.4	74	4.0	41	10.3
7.1					4200	2.29	9.4	77			
7.2					3600	3.03	9	80			
7.3					3050	3.49	8.9	82			
8.0	—	790	1105	1290	—	—	—	—	6.0	60	10.0
8.1	3400				1.81	7.7	73				
8.2	3050				2.46	7.5	78				
8.3	2600				2.84	7.4	80				

## Rating Sheets and Derate Curves

Vollgeblechter Gleichstrom – Nebenschlußmotor  
vollkommen geschlossen, unbelüftet  
Laminated DC – Motor with Shunt Field  
totally enclosed, non ventilated  
TYPE : GK1305

Schutzart .....	IP44 .....	Enclosure
Erregerleistung .....	175 W .....	Exciter Rating
Erregerzeitkonstante (ungesättigt) .....	150 ms .....	Exciter field constant (unsaturated)
Läuferträgheitsmoment I .....	0.11 kg-m <sup>2</sup> .....	Moment of Inertia
Läuferschwingmoment GD <sup>2</sup> .....	0.43 kg-m <sup>2</sup> .....	Flywheel Effect GD <sup>2</sup>
Maschinengewicht .....	166 kg .....	Motor Weight

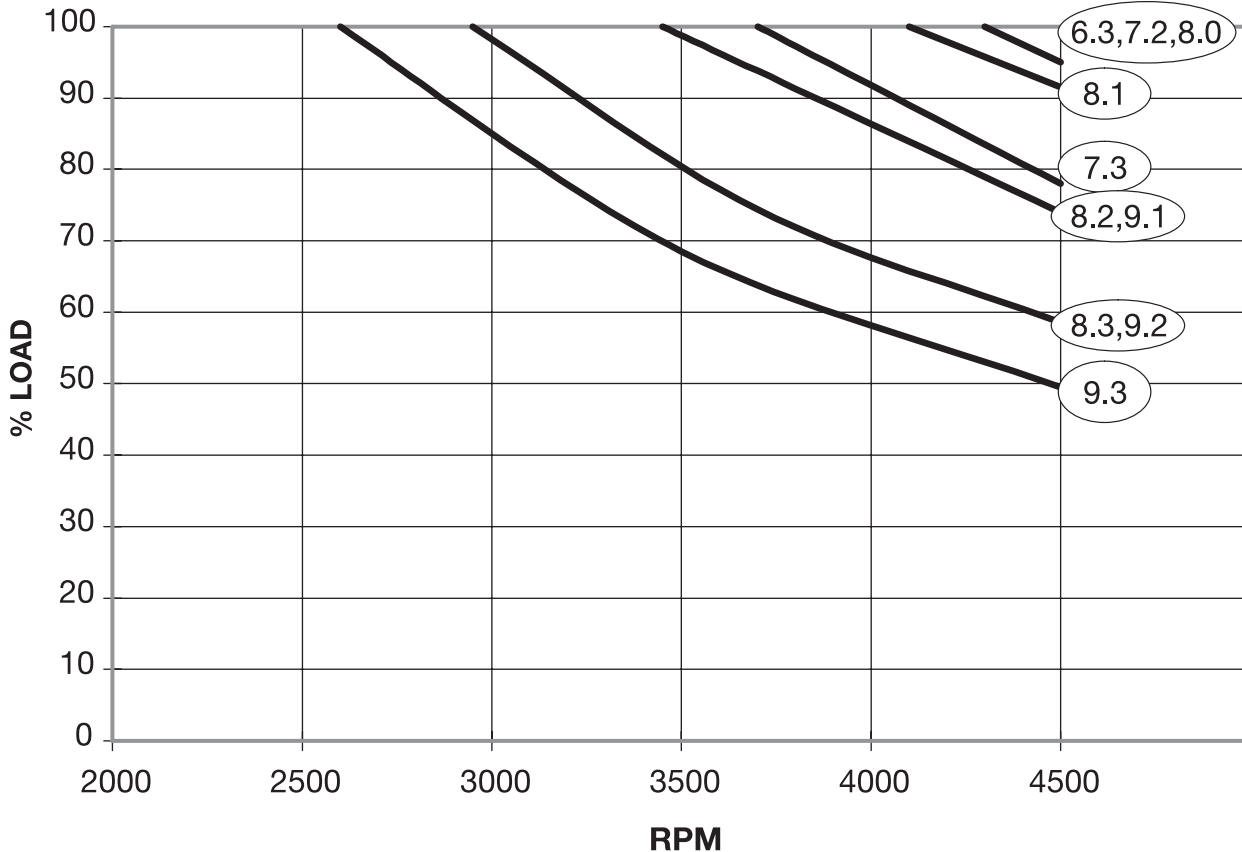

Leistungsreduktion bei Feldschwächung ..... maximal zulässige Drehzahl n = 4500 U / min  
Reduction of listed rating at Field Weakening ..... maximum safe speed n = 4500 RPM

## Rating Sheets and Derate Curves

Vollgeblechter Gleichstrom – Nebenschlußmotor  
 vollkommen geschlossen, unbelüftet  
 Laminated DC – Motor with Shunt Field  
 totally enclosed, non ventilated  
 TYPE : GK1305

Ankerkreis Armature	Nenn-drehzahl (U/min) bei Ankerspannung Base speed (RPM) at armature voltage				Feld- steuerg Field Control U/min RPM	Nenn- leistung Nominal Rating kW	Nenn- Strom Nominal Current Amps	Wirkungs- grad Efficiency %	Ankerkreis / Armature		
	260	300	400	460					Widerstand Resistance warm Ohms	Induktivität Inductance mH	Zeit- Konstante Time- Constant ms
1.0	2290	2670	—	—	4500	4.65	20.9	84	0.81	8.5	10.5
					4500	5.2	20	85			
					—	—	—	—			
					—	—	—	—			
2.0	2070	2415	—	—	4500	4.3	19.4	83	0.97	10	10.3
					4500	4.85	18.8	84			
					—	—	—	—			
					—	—	—	—			
3.0	1885	2205	2990	—	4500	4.1	18.6	83	1.10	12	10.9
					4500	4.7	18.2	84			
					4500	5.45	15.7	85			
					—	—	—	—			
4.0	1585	1850	2545	2920	4500	3.75	17	82	1.3	14	10.8
					4500	4.25	16.6	84			
					4500	5.25	15.1	85			
					4500	5.3	13.2	85			
5.0	1345	1590	2170	2520	4500	3.3	15.2	81	1.6	16	10.0
					4500	3.8	14.9	82			
					4500	4.75	13.7	84			
					4500	4.9	12.3	84			
6.0 6.1 6.2 6.3	1165	1380	1885	2190	4500	3.1	14.3	80	1.8	19	10.6
					4500	3.55	14	81			
					4500	4.5	13	83			
					4450	4.7	11.8	84			
7.0 7.1 7.2 7.3	1015	1190	1645	1915	4500	2.7	12.8	77	2.3	24	10.4
					4500	3.15	12.6	80			
					4300	4.1	12	83			
					3700	4.6	11.5	83			
8.0 8.1 8.2 8.3	795	940	1305	1520	4350	2.19	10.5	75	3.5	37	10.6
					4100	2.55	10.4	77			
					3450	3.4	10.1	81			
					2950	3.9	9.9	82			
9.0 9.1 9.2 9.3	—	805	1115	1305	—	—	—	—	4.5	48	10.7
					3550	2.25	9.3	76			
					3050	3	9	80			
					2600	3.45	8.9	81			

## Rating Sheets and Derate Curves

Vollgeblechter Gleichstrom – Nebenschlußmotor  
vollkommen geschlossen, unbelüftet  
Laminated DC – Motor with Shunt Field  
totally enclosed, non ventilated  
TYPE : GK1307

Schutzart .....	IP44 .....	Enclosure
Erregerleistung .....	200 W .....	Exciter Rating
Erregerzeitkonstante (ungesättigt) .....	180 ms .....	Exciter field constant (unsaturated)
Läuferträgheitsmoment I .....	0.12 kg-m <sup>2</sup> .....	Moment of Inertia
Läuferschwingmoment GD <sup>2</sup> .....	0.48 kg-m <sup>2</sup> .....	Flywheel Effect GD <sup>2</sup>
Maschinengewicht .....	179 kg .....	Motor Weight

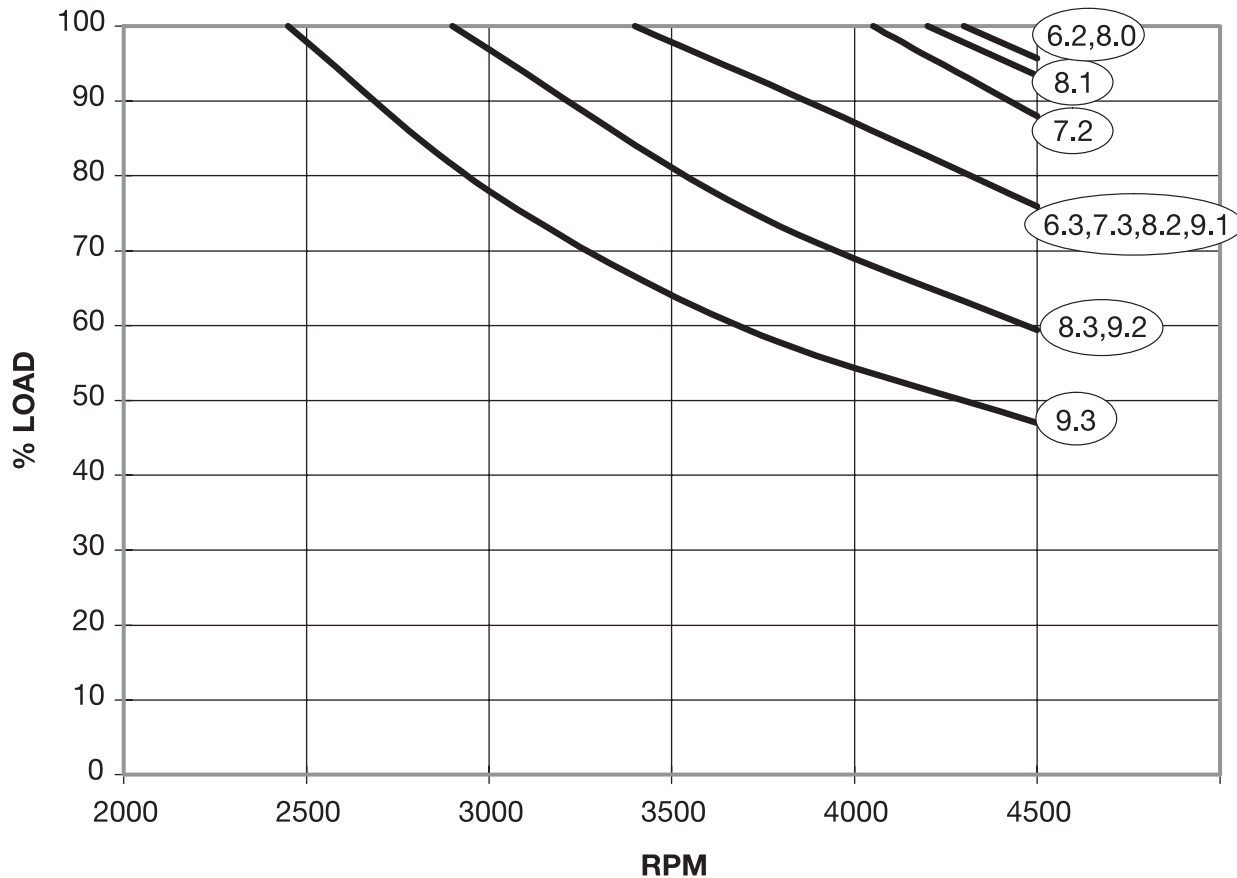

Leistungsreduktion bei Feldschwächung ..... maximal zulässige Drehzahl n = 4500 U / min  
Reduction of listed rating at Field Weakening ..... maximum safe speed n = 4500 RPM

## Rating Sheets and Derate Curves

Vollgeblechter Gleichstrom – Nebenschlußmotor  
vollkommen geschlossen, unbelüftet  
Laminated DC – Motor with Shunt Field  
totally enclosed, non ventilated  
TYPE : GK1307

Ankerkreis Armature	Nenn-drehzahl (U/min) bei Ankerspannung Base speed (RPM) at armature voltage				Feld- steuerg Field Control U/min RPM	Nenn- leistung Nominal Rating kW	Nenn- Strom Nominal Current Amps	Wirkungs- grad Efficiency %	Ankerkreis / Armature		
	260	300	400	460					Widerstand Resistance warm Ohms	Inductivität Inductance mH	Zeit- Konstante Time- Constant ms
1.0	2390	2785	—	—	4500	5.7	25.2	85	0.57	6.5	11.4
					4500	6.25	23.8	86			
					—	—	—	—			
2.0	2105	2455	—	—	4500	5.2	23.1	85	0.72	8.3	11.5
					4500	5.85	22.3	85			
					—	—	—	—			
3.0	1875	2190	2970	—	4500	4.7	21.1	84	0.92	10	10.9
					4500	5.3	20.5	85			
					4500	6.1	17.5	85			
4.0	1560	1820	2475	—	4500	4.25	19.1	83	1.1	12	10.9
					4500	4.85	18.7	84			
					4500	5.9	16.9	85			
5.0	1310	1545	2100	2440	4500	3.95	17.9	82	1.3	15	11.5
					4500	4.55	17.6	83			
					4500	5.65	16.2	85			
					4500	5.85	14.5	85			
6.0	1095	1290	1780	2065	4500	3.3	15.2	80	1.8	20	11.1
					4500	3.75	14.9	81			
					4300	4.9	14.2	84			
6.3	1095	1290	1780	2065	3650	5.5	13.7	85	1.8	20	11.1
					4500	3.1	14.3	79			
					4500	3.55	14.1	81			
7.0	955	1125	1540	1805	4500	3.1	14.3	79	2.0	23	11.5
					4500	3.55	14.1	81			
					4050	4.65	13.4	83			
7.3	955	1125	1540	1805	3400	5.2	13	84	2.0	23	11.5
					4500	3.1	14.3	79			
					4500	3.55	14.1	81			
8.0	830	975	1340	1575	4400	2.7	12.8	77	2.6	29	11.2
					4200	3.15	12.6	79			
					3550	4.15	12.1	82			
8.3	830	975	1340	1575	3000	4.75	11.9	83	2.6	29	11.2
					4500	3.1	14.3	79			
					4500	3.55	14.1	81			
9.0	—	765	1060	1240	—	—	—	—	4.0	45	11.3
					3400	2.5	10.3	76			
					2900	3.4	10.1	80			
9.3	—	765	1060	1240	2450	3.9	9.9	—	4.0	45	11.3
					—	—	—	—			

## Rating Sheets and Derate Curves

Vollgeblechter Gleichstrom – Nebenschlußmotor  
vollkommen geschlossen, unbelüftet  
Laminated DC – Motor with Shunt Field  
totally enclosed, non ventilated  
TYPE : GK1309

Schutzart .....	IP44 .....	Enclosure
Erregerleistung .....	225 W .....	Exciter Rating
Erregerzeitkonstante (ungesättigt) .....	180 ms .....	Exciter field constant (unsaturated)
Läuferträgheitsmoment I .....	0.13 kg-m <sup>2</sup> .....	Moment of Inertia
Läuferschwingmoment GD <sup>2</sup> .....	0.52 kg-m <sup>2</sup> .....	Flywheel Effect GD <sup>2</sup>
Maschinengewicht .....	191 kg .....	Motor Weight

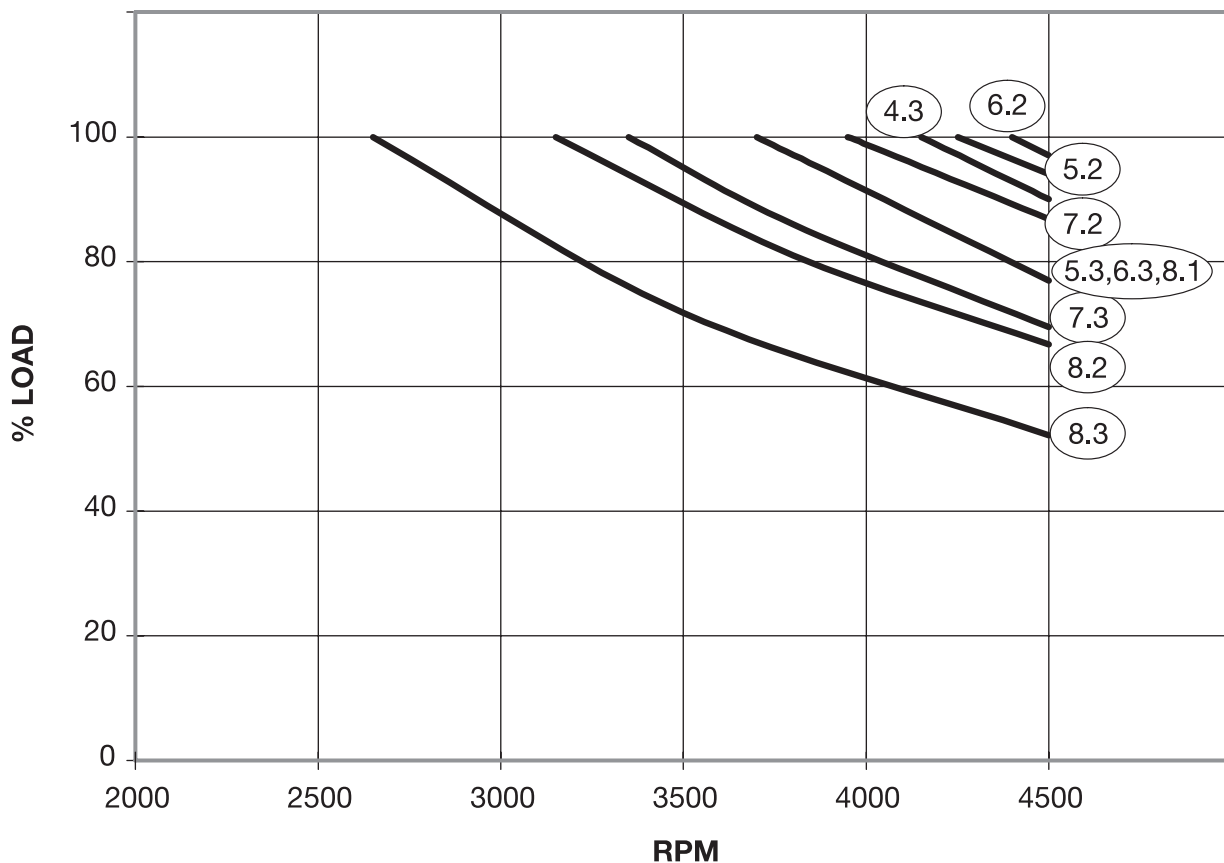

Leistungsreduktion bei Feldschwächung ..... maximal zulässige Drehzahl n = 4500 U / min  
Reduction of listed rating at Field Weakening ..... maximum safe speed n = 4500 RPM



## Rating Sheets and Derate Curves

Vollgeblechter Gleichstrom – Nebenschlußmotor  
vollkommen geschlossen, unbelüftet  
Laminated DC – Motor with Shunt Field  
totally enclosed, non ventilated  
TYPE : GK1309

Ankerkreis Armature	Nennzahl (U/min) bei Ankerspannung Base speed (RPM) at armature voltage				Feld- steuerung Field Control U/min RPM	Nenn- leistung Nominal Rating kW	Nenn- Strom Nominal Current Amps	Wirkungs- grad Efficiency %	Ankerkreis / Armature		
	260	300	400	460					Widerstand Resistance warm Ohms	Induktivität Inductance mH	Zeit- Konstante Time- Constant ms
1.0	2235	2600	—	—	4500 4500 — —	5.8 6.5 — —	25.8 24.9 — —	85 86 — —	0.62	7.4	11.9
2.0	1965	2295	3145	—	4500 4500 4500 —	5.25 5.9 7 —	23.4 22.8 20 —	85 85 86 —	0.79	9.4	11.9
3.0	1750	2045	2810	3260	4500 4500 4500 4500	4.7 5.4 6.75 7	21.2 20.8 19.3 17.3	83 85 86 86	1.0	11.6	11.6
4.0 4.1 4.2 4.3	1430	1695	2300	2705	4500 4500 4500 4150	4.25 4.85 6.25 6.8	19.2 18.9 17.8 16.8	83 84 85 86	1.2	14	11.7
5.0 5.1 5.2 5.3	1210	1420	1950	2265	4500 4500 4250 3700	4 4.6 5.9 6.55	18.1 17.8 16.9 16.2	82 83 85 86	1.4	17	12.1
6.0 6.1 6.2 6.3	1125	1330	1810	2100	4500 4500 4400 3800	3.9 4.5 5.75 6.3	17.7 17.4 16.4 15.5	82 83 85 86	1.4	17	12.1
7.0 7.1 7.2 7.3	880	1040	1425	1655	4500 4500 3950 3350	3.1 3.6 4.75 5.35	14.5 14.3 13.7 13.3	78 80 83 84	2.0	22	11.0
8.0 8.1 8.2 8.3	—	830	1155	1345	— 3750 3150 2650	— 3.05 4.1 4.7	— 12.4 12 11.8	— 78 82 83	2.8	33	11.8

## Rating Sheets and Derate Curves

Vollgeblechter Gleichstrom – Nebenschlußmotor  
vollkommen geschlossen, unbelüftet  
Laminated DC – Motor with Shunt Field  
totally enclosed, non ventilated  
TYPE : GK1311

Schutzart .....	IP44 .....	Enclosure
Erregerleistung .....	250 W .....	Exciter Rating
Erregerzeitkonstante (ungesättigt) .....	200 ms .....	Exciter field constant (unsaturated)
Läuferträgheitsmoment I .....	0.15 kg-m <sup>2</sup> .....	Moment of Inertia
Läuferschwingmoment GD <sup>2</sup> .....	0.61 kg-m <sup>2</sup> .....	Flywheel Effect GD <sup>2</sup>
Maschinengewicht .....	215 kg .....	Motor Weight

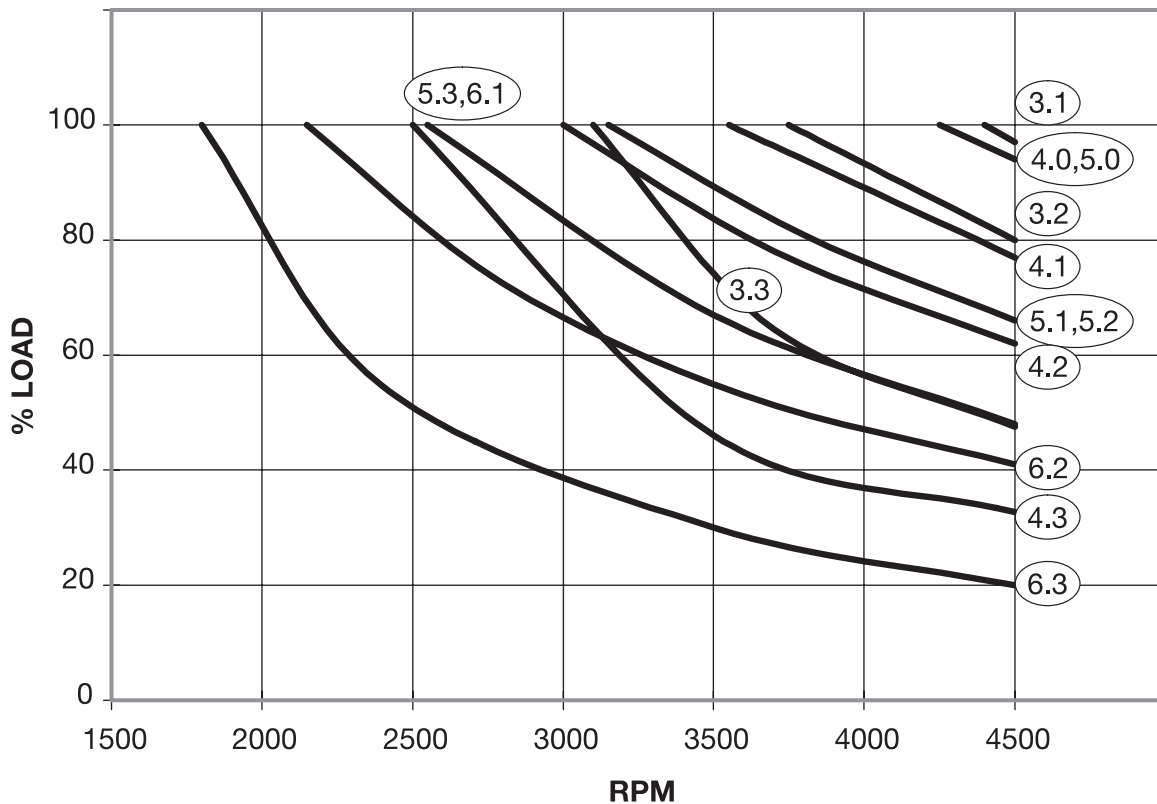

Leistungsreduktion bei Feldschwächung ..... maximal zulässige Drehzahl n = 4500 U / min  
Reduction of listed rating at Field Weakening ..... maximum safe speed n = 4500 RPM

## Rating Sheets and Derate Curves

Vollgeblechter Gleichstrom – Nebenschlußmotor  
 vollkommen geschlossen, unbelüftet  
 Laminated DC – Motor with Shunt Field  
 totally enclosed, non ventilated  
 TYPE : GK1311

Ankerkreis Armature	Nennzahl (U/min) bei Ankerspannung Base speed (RPM) at armature voltage				Feld- steuerg Field Control U/min RPM	Nenn- leistung Nominal Rating kW	Nenn- Strom Nominal Current Amps	Wirkungs- grad Efficiency %	Ankerkreis / Armature		
	300	400	460	520					Widerstand Resistance warm Ohms	Induktivität Inductance mH	Zeit- Konstante Time- Constant ms
1.0	1960	2655	—	—	4500 4500 — —	6.4 8 — —	24.6 22.5 — —	86 87 — —	0.75	9.0	12.0
2.0	1570	2155	2505	—	4500 4500 4500 —	5.6 7.2 7.7 —	21.7 20.3 18.8 —	84 86 86 —	0.94	12	12.8
3.0 3.1 3.2 3.3	1295	1785	2070	2360	4500 4400 3750 3100	5 6.5 7.2 7.3	19.6 18.5 17.7 15.8	83 85 86 86	1.2	15	12.5
4.0 4.1 4.2 4.3	1000	1365	1585	1825	4250 3550 3000 2500	4.3 5.6 6.3 7	16.9 16.2 15.7 15.3	82 84 85 86	1.6	21	13.1
5.0 5.1 5.2 5.3	885	1150	1435	1640	4250 3200 3150 2550	3.5 4.7 5.4 6	14.3 13.8 13.6 13.3	79 82 84 85	2.4	28	11.7
6.0 6.1 6.2 6.3	—	930	1085	1240	— 2550 2150 1800	— 4 4.6 5.2	— 12 11.8 11.6	— 81 82 84	3.3	42	12.7

## Rating Sheets and Derate Curves

Vollgeblechter Gleichstrom – Nebenschlußmotor  
vollkommen geschlossen, unbelüftet  
Laminated DC – Motor with Shunt Field  
totally enclosed, non ventilated  
TYPE : GK1606

Schutzart .....	IP44 .....	Enclosure
Erregerleistung .....	400 W .....	Exciter Rating
Erregerzeitkonstante (ungesättigt) .....	250 ms .....	Exciter field constant (unsaturated)
Läuferträgheitsmoment I .....	0.26 kg-m <sup>2</sup> .....	Moment of Inertia
Läuferschwingmoment GD <sup>2</sup> .....	1.0 kg-m <sup>2</sup> .....	Flywheel Effect GD <sup>2</sup>
Maschinengewicht .....	274 kg .....	Motor Weight

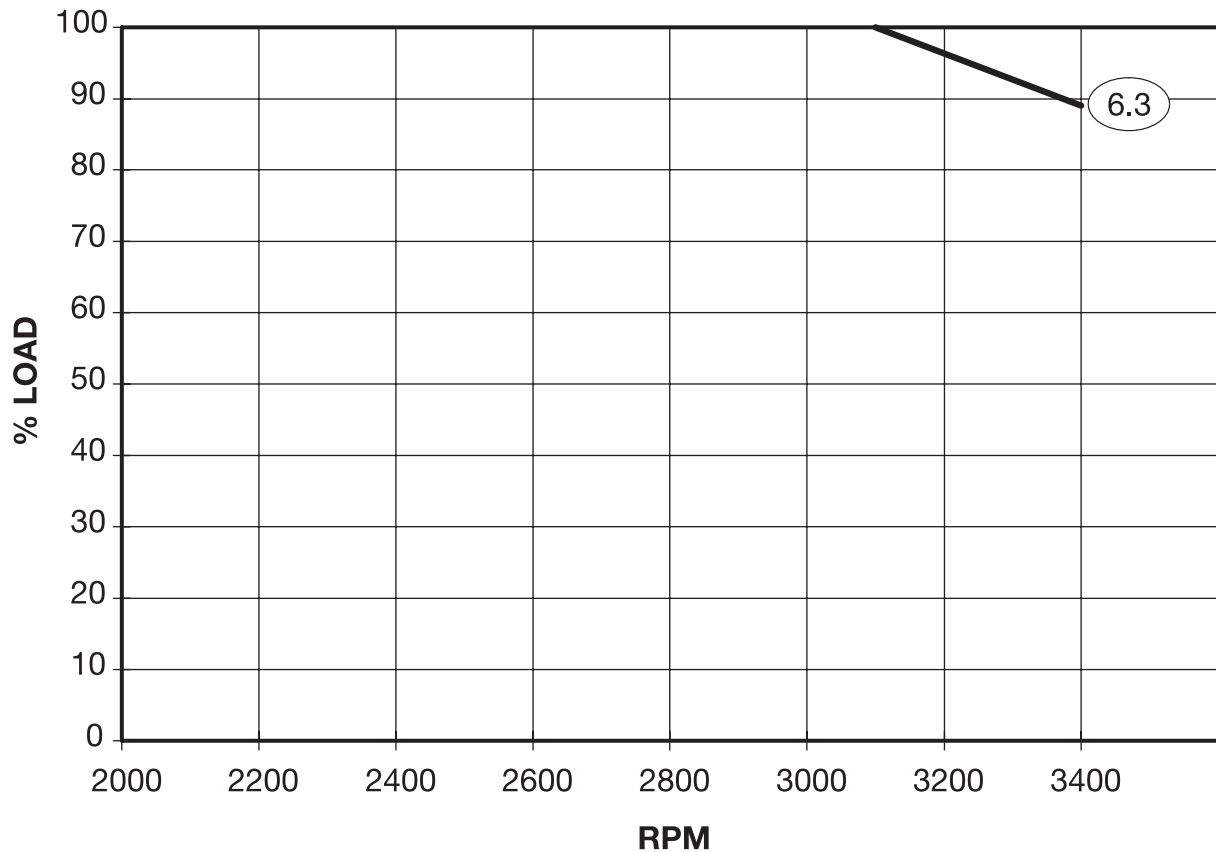

Leistungsreduktion bei Feldschwächung ..... maximal zulässige Drehzahl n = 4500 U / min  
Reduction of listed rating at Field Weakening ..... maximum safe speed n = 4500 RPM

## Rating Sheets and Derate Curves

Vollgeblechter Gleichstrom – Nebenschlußmotor  
vollkommen geschlossen, unbelüftet  
Laminated DC – Motor with Shunt Field  
totally enclosed, non ventilated  
TYPE : GK1606

Ankerkreis Armature	Nennzahl (U/min) bei Ankerspannung Base speed (RPM) at armature voltage				Feld- steuerg Field Control U/min RPM	Nenn- leistung Nominal Rating kW	Nenn- Strom Nominal Current Amps	Wirkungs- grad Efficiency %	Ankerkreis / Armature		
	300	400	460	520					Widerstand Resistance warm Ohms	Induktivität Inductance mH	Zeit- Konstante Time- Constant ms
1.0	1785	2415	—	—	3400	9.7	36.1	87	0.42	6.4	15.2
	—				3400	10.5	29.3	88			
	—	—	—	—	—	—	—	—			
2.0	1365	1835	—	—	3400	8.6	32.4	86	0.54	8.5	15.7
	—				3400	9.9	27.5	87			
	—	—	—	—	—	—	—	—			
3.0	1115	1515	1760	—	3400	7.5	28.5	85	0.70	11	15.7
	—				3400	9	25	86			
	—	3400	9.3	22.4	87	—	—	—			
4.0	945	1290	1500	1705	3400	6.9	26.2	84	0.88	13	14.8
	—				3400	8.4	23.6	86			
	—	3400	8.9	21.7	87						
	—	3400	9	19.3	87						
5.0	845	1150	1335	1520	3400	6.2	23.9	82	1.1	16	14.5
	—				3400	7.8	21.8	85			
	—	3400	8.4	20.4	86						
	—	3400	8.7	18.6	86						
6.0	700	955	1110	1270	3400	5.1	20.2	80	1.6	22	13.8
6.1					3400	6.6	19	83			
6.2					3400	7.4	18.2	85			
6.3					3100	8	17.2	85			

## Rating Sheets and Derate Curves

Vollgeblechter Gleichstrom – Nebenschlußmotor  
vollkommen geschlossen, unbelüftet  
Laminated DC – Motor with Shunt Field  
totally enclosed, non ventilated  
TYPE : GK1608

Schutzart .....	IP44 .....	Enclosure
Erregerleistung .....	400 W .....	Exciter Rating
Erregerzeitkonstante (ungesättigt) .....	300 ms .....	Exciter field constant (unsaturated)
Läuferträgheitsmoment I .....	0.32 kg-m <sup>2</sup> .....	Moment of Inertia
Läuferschwungmoment GD <sup>2</sup> .....	1.3 kg-m <sup>2</sup> .....	Flywheel Effect GD <sup>2</sup>
Maschinengewicht .....	313 kg .....	Motor Weight

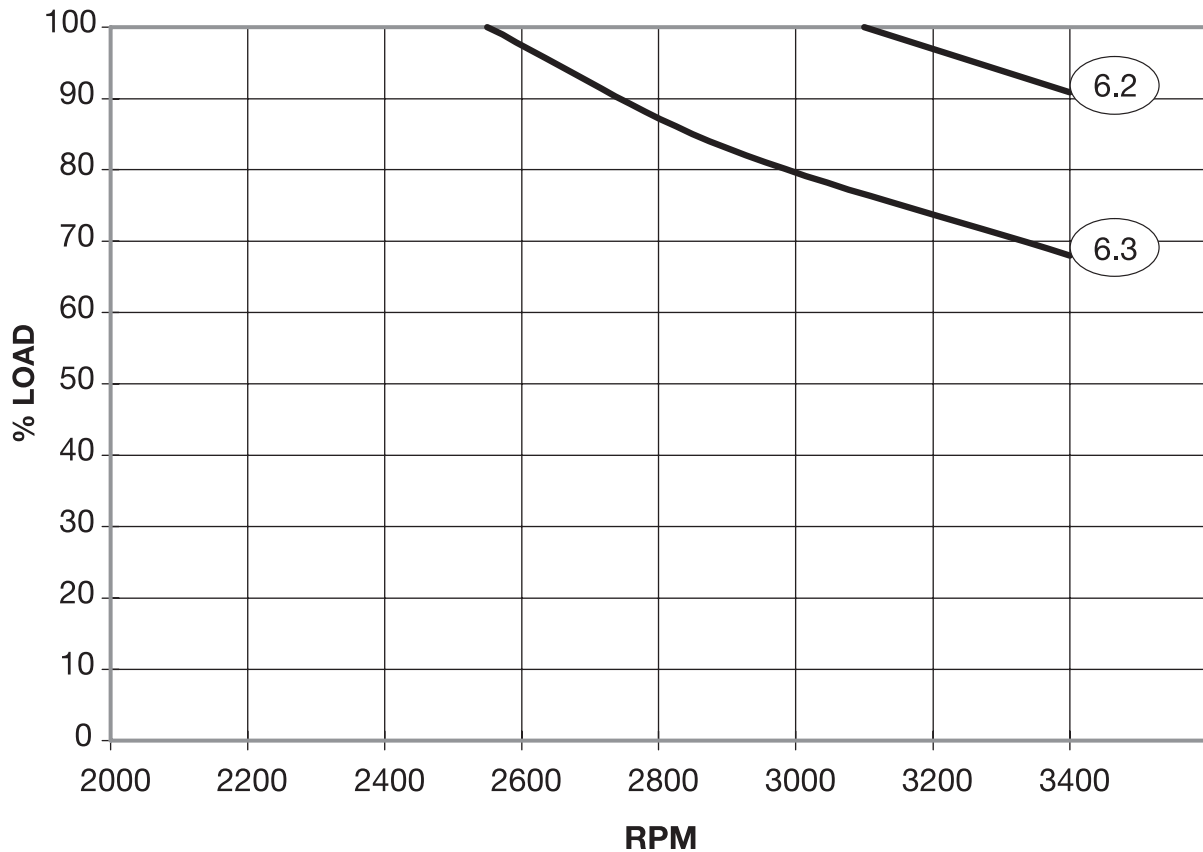

Leistungsreduktion bei Feldschwächung ..... maximal zulässige Drehzahl n = 4500 U / min  
Reduction of listed rating at Field Weakening ..... maximum safe speed n = 4500 RPM

## Rating Sheets and Derate Curves

Vollgeblechter Gleichstrom – Nebenschlußmotor  
 vollkommen geschlossen, unbelüftet  
 Laminated DC – Motor with Shunt Field  
 totally enclosed, non ventilated  
 TYPE : GK1608

Ankerkreis Armature	Nenn-drehzahl (U/min) bei Ankerspannung Base speed (RPM) at armature voltage				Feld- steuerg Field Control U/min RPM	Nenn- leistung Nominal Rating kW	Nenn- Strom Nominal Current Amps	Wirkungs- grad Efficiency %	Ankerkreis / Armature		
	400	460	520	600					Widerstand Resistance warm Ohms	Induktivität Inductance mH	Zeit- Konstante Time- Constant ms
1.0	2645	—	—	—	3400	13.5	37.2	89	0.28	4.4	15.9
2.0	2055	—	—	—	3400	12.4	34.4	88	0.39	6.1	15.6
3.0	1530	1775	—	—	3400 3400	11.4 11.7	31.6 28.2	88 88	0.52	8.5	16.5
4.0	1190	1380	—	—	3400 3400	10.2 10.7	28.4 25.8	87 87	0.66	10.5	15.9
5.0	1035	1200	1365	—	3400 3400 3400	9 9.7 10	25.1 23.4 21.3	85 86 86	0.87	14	16.2
6.0	925	—	—	—	3400	8	22.4	84	1.1	18	16.4
6.1	—	1070	—	—	3400	9.2	22.3	85			
6.2	—	—	1220	—	3100	9.8	20.9	86			
6.3	—	—	—	1425	2550	10	18.4	86			

## Rating Sheets and Derate Curves

Vollgeblechter Gleichstrom – Nebenschlußmotor  
vollkommen geschlossen, unbelüftet  
Laminated DC – Motor with Shunt Field  
totally enclosed, non ventilated  
TYPE : GK1610

Schutzart .....	IP44 .....	Enclosure
Erregerleistung .....	500 W .....	Exciter Rating
Erregerzeitkonstante (ungesättigt) .....	350 ms .....	Exciter field constant (unsaturated)
Läuferträgheitsmoment I .....	0.40 kg-m <sup>2</sup> .....	Moment of Inertia
Läuferschwungmoment GD <sup>2</sup> .....	1.6 kg-m <sup>2</sup> .....	Flywheel Effect GD <sup>2</sup>
Maschinengewicht .....	363 kg .....	Motor Weight

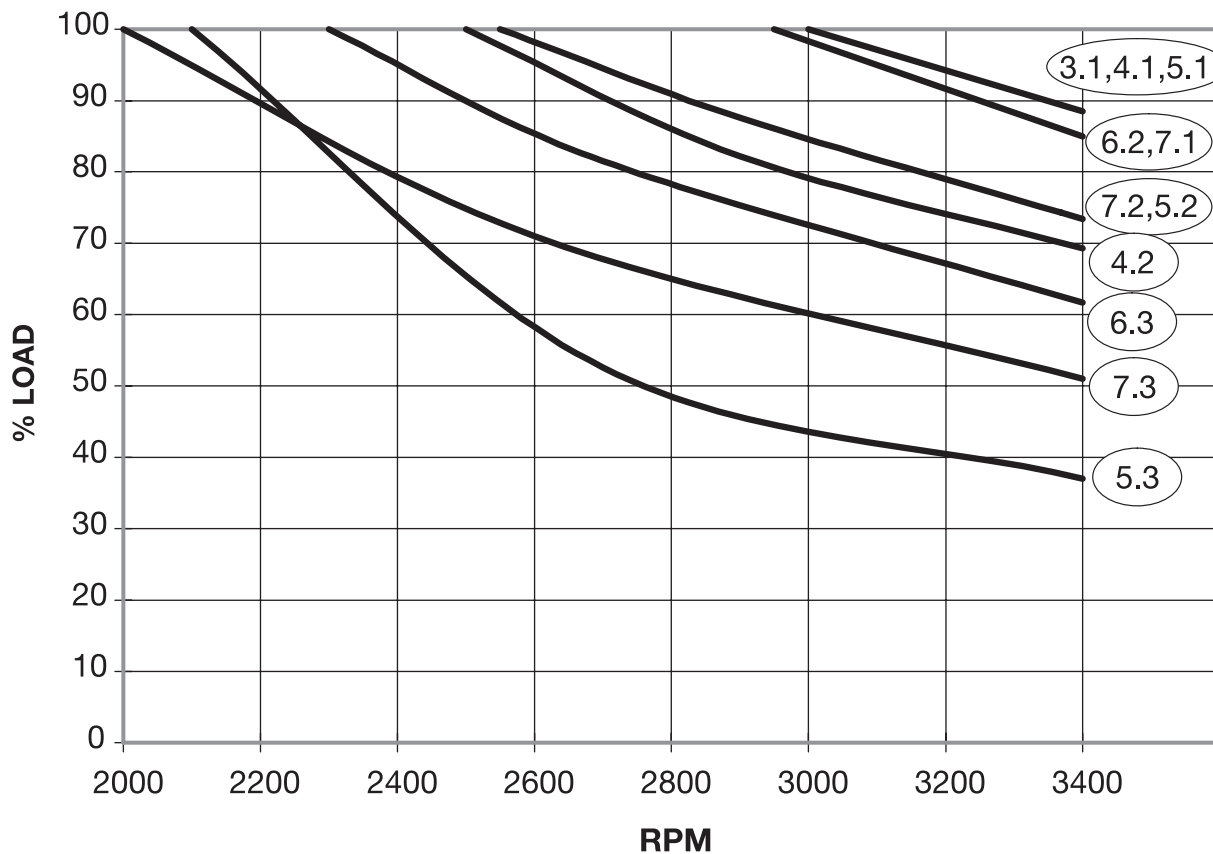

Leistungsreduktion bei Feldschwächung ..... maximal zulässige Drehzahl n = 3400 U / min  
Reduction of listed rating at Field Weakening ..... maximum safe speed n = 3400 RPM



## Rating Sheets and Derate Curves

Vollgeblechter Gleichstrom – Nebenschlußmotor  
vollkommen geschlossen, unbelüftet  
Laminated DC – Motor with Shunt Field  
totally enclosed, non ventilated  
TYPE : GK1610

Ankerkreis Armature	Nennzahl (U/min) bei Ankerspannung Base speed (RPM) at armature voltage				Feld- steuerg Field Control U/min RPM	Nenn- leistung Nominal Rating kW	Nenn- Strom Nominal Current Amps	Wirkungs- grad Efficiency %	Ankerkreis / Armature		
	400	460	520	600					Widerstand Resistance warm Ohms	Induktivität Inductance mH	Zeit- Konstante Time- Constant ms
1.0	1960	2270	—	—	3400 3400 — —	15.7 16.3 — —	43.1 38.7 — —	89 89 — —	0.34	5.7	17
2.0	1660	1925	—	—	3400 3400 — —	14.7 14.9 — —	40.2 35.5 — —	89 89 — —	0.34	5.7	17
3.0 3.1	1350	1565	—	—	3400 3100 — —	13.1 13.5 — —	36.3 32.4 — —	88 88 — —	0.48	8.2	17.1
4.0 4.1 4.2	1060	1240	1415	—	3400 3000 2500 —	10.7 12 12.6 —	29.7 28.9 26.6 —	86 87 87 —	0.64	11	17.3
5.0 5.1 5.2 5.3	885	1025	1175	1365	3400 3100 2600 2100	9 10.5 11.8 12.3	25.1 25.3 25 22.5	85 86 87 87	0.82	15	18.4
6.0 6.1 6.2 6.3	765	890	1015	1180	3400 3300 2950 2300	8 9 9.6 10	22.4 21.8 20.5 18.5	83 85 85 86	1.0	18	17.3
7.0 7.1 7.2 7.3	690	795	905	1055	3400 2950 2550 2000	6.8 8.2 9.1 9.8	19.1 19.9 19.4 18	82 84 85 85	1.3	23	17.7

## Industrial Direct Current Motors and Generators – RPM III

### Dimension Sheets

Enclosure	Method of Cooling	Mounting	Accessories	Frames	D/S Number	Page
IP23	IC17	Foot	None	GK1104-GK1110	616078-613	89
				GK1303-GK1311	616008-613	90
				GK1606-GK1610	616018-613	91
				GK1808-UGK1810	616028-613	92
				GK2008-UGK2010	616038-613	93
				GK2208-UGK2210	616048-613	94
				GK2508-UGK2510	616068-613	95
				GK2806-GK2810	616493-601	96
IP23	IC06	Foot	Air Filter	GK1104-GK1110	616077-601	97
				GK1303-GK1311	616007-601	98
				GK1606-GK1610	616017-601	99
				GK1808-UGK1810	616027-601	100
				GK2008-ULGK2010	616037-601	101
				GK2208-ULGK2210	616047-601	102
				GK2508-UGK2510	616067-601	103
IP23	IC06	Foot	Air Filter and Flange Mounted Tacho	GK1104-GK1110	616077-602	104
				GK1303-GK1311	616007-602	105
				GK1606-GK1610	616017-602	106
				GK1808-UGK1810	616027-602	107
				GK2008-ULGK2010	616037-602	108
				GK2208-ULGK2210	616047-602	109
				GK2508-UGK2510	616067-602	110
				GK2806-GK2810	616492-602	111
IP23	IC06	Flange	Air Filter	GK1303Y-GK1311Y	616007-603	112
				GK1606Y-GK1610Y	616017-603	113
IP23	IC06	Flange	Air Filter and Flange Mounted Tacho	GK1606Y-GK1610Y	616017-604	114
				GK1808Y-GK1810Y	616027-604	115
IP44	IC410	Foot	—	GK1104-GK1110	616075-601	116
				GK1303-GK1311	616005-601	117
				GK1606-GK1610	616015-601	118
IP44	IC37	Foot	Flange Mounted Tacho	GK2806-GK2810	616493-602	119

# Industrial Direct Current Motors and Generators – RPM III

**ENCLOSURE:** Drip-Proof IP23  
**METHOD OF DRIVE:** Coupled or Belted

**COOLING:** Separate Ventilated IC17  
**MOUNTING:** Foot

## IEC TYPES GK1104 THRU GK1110

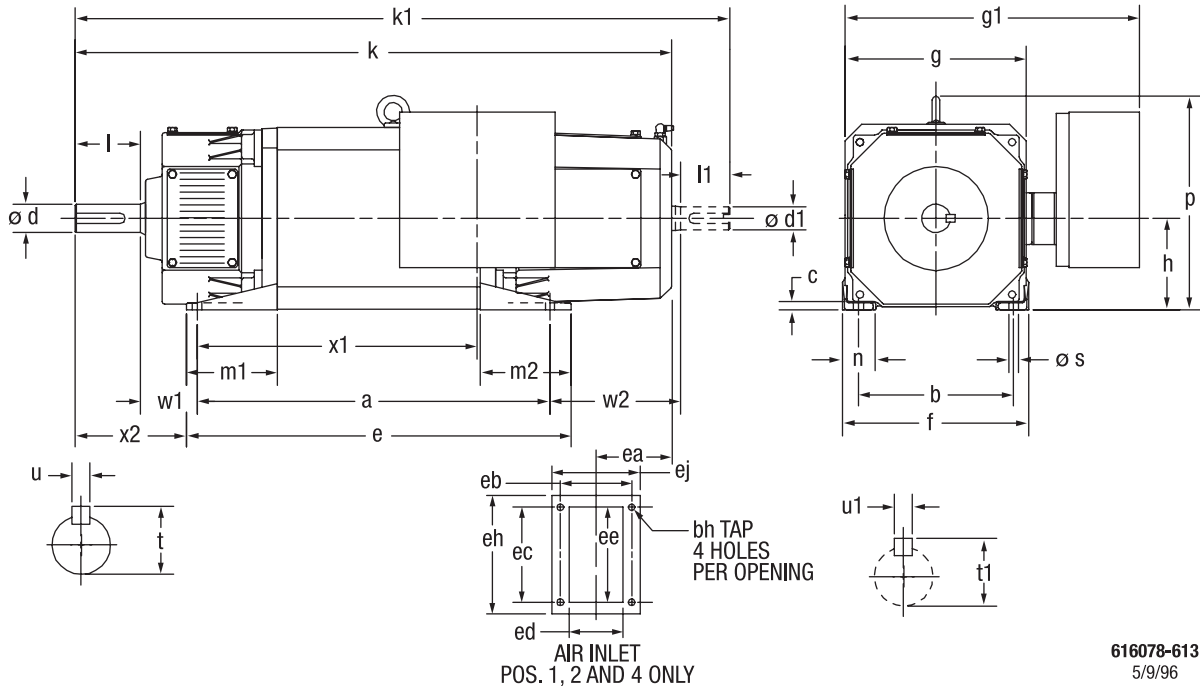

616078-613  
5/9/96

TYPE	DIN IEC	b A	c HA	f AB	g AC	h H	n AA	p HD	s K	w1 C	ea	eb	ec	ed	ee	ef	eh	ej	bh
GK1104-GK1110		190	6	229	222	112	35	269	12	70	94	108	108	105	99	103	121	121	M6-1.0

TYPE	DIN IEC	a B	e BB	k L	k1 LC	m1 BA	m2	x2	w2 CA	DRIVE END SHAFT				OPPOSITE DRIVE END SHAFT				WT. KG.
										d D	l E	t GA	u F	d1 DA	l1 EA	t1 GC	u1 FA	
GK1104		318	356	616	688	111	111	137	160	38	80	41	10	28	60	31	8	84
GK1106		356	394	655	726	111	111	137	160	38	80	41	10	28	60	31	8	93
GK1108		406	445	705	776	111	111	137	160	38	80	41	10	28	60	31	8	111
GK1110		432	471	731	802	111	111	137	160	38	80	41	10	28	60	31	8	120

TYPE	DIN IEC	amps	x1	g1	CONDUIT SIZE
GK1104		100	228	361	Pg29,Pg16

TYPE	DIN IEC	amps	x1	g1	CONDUIT SIZE
GK1106		100	266	361	Pg29,Pg16

TYPE	DIN IEC	amps	x1	g1	CONDUIT SIZE
GK1108		100	317	361	Pg29,Pg16

TYPE	DIN IEC	amps	x1	g1	CONDUIT SIZE
GK1110		100	343	361	Pg29,Pg16

- (1) "h" Dimension Will Not Be Exceeded. Shims Up To .5 mm In Thickness Are Usually Required For Coupled Or Geared Machines.
- (2) Shaft Extensions Are According To DIN 746. Tolerances Are Based On The ISA-Fitting System Using k6 For Diameters Up To 50 mm And m6 For Diameters Above.
- (3) The Terminal Box Size Varies With Horsepower And Voltage.
- (4) The Terminal Box Can Be Placed On The Right Or Left, Dimensions Remain The Same.
- (5) Tolerance Of Dimensions Are According To DIN.
- (6) Opposite Drive End Shaft Supplied Only When Specified.

Terminal Box Can Be Rotated For Lead Outlet At Top, Sides Or Bottom.  
Terminal Box Located On Opposite Side When F-1, W-2, W-3, W-6, W-8, Or C-2 Mounting Is Specified. Box Located On Top When Specified.  
Blower Assembly Can Be Located At Positions 1, 2, Or 4, Except Blower Assembly And Terminal Box Can Not Be Located At The Same Position.  
Motor Weight May Vary 15% For Non-Standard Ratings And/Or Accessories.  
If Mounting Clearance Details Are Required, Consult Factory.

**Industrial Direct Current Motors and Generators – RPM III**

**ENCLOSURE:** Drip-Proof IP23  
**METHOD OF DRIVE:** Coupled or Belted

**COOLING:** Separate Ventilated IC17  
**MOUNTING:** Foot

**IEC TYPES GK1303 THRU GK1311**

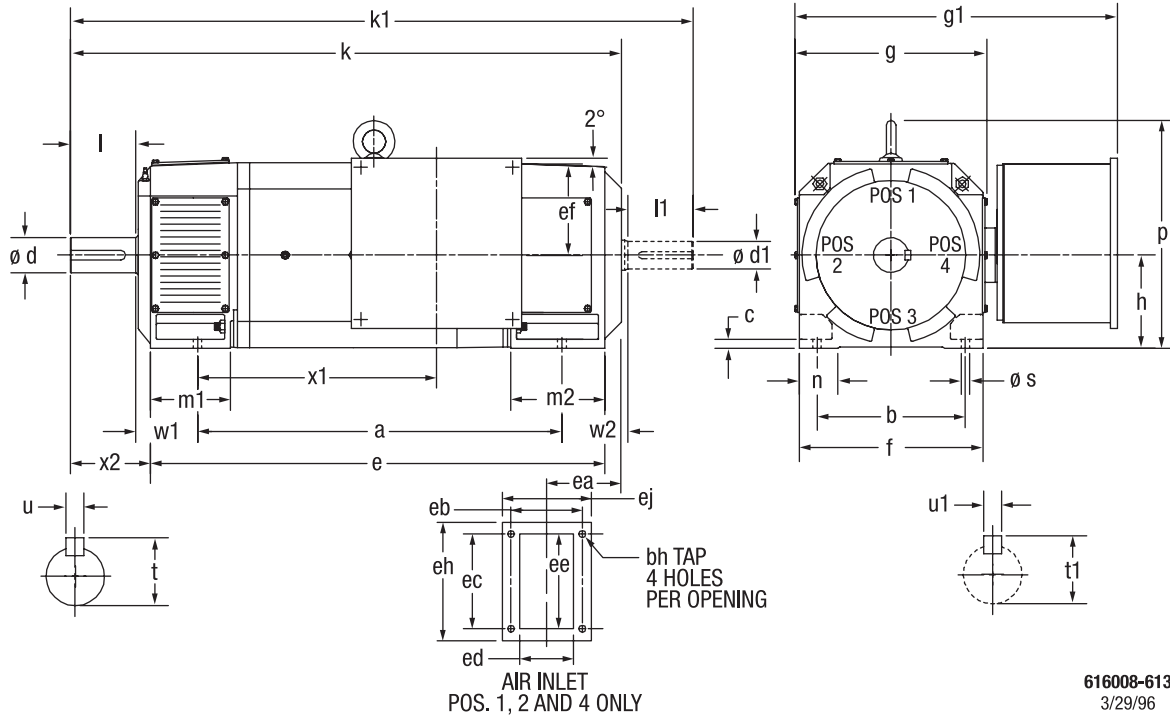

TYPE	DIN IEC	b A	c HA	f AB	g AC	h H	n AA	s K	w1 C	ea	eb	ec	ed	ee	ef	eh	ej	bh
GK1303-GK1311		216	11	260	275	132	48	12	89	127	143	152	127	152	130	168	159	M8-1.25

TYPE	DIN IEC	a B	e BB	k L	k1 LC	m1 BA	m2 --	p HD	x2 --	w2 CA	DRIVE END SHAFT				OPPOSITE DRIVE END SHAFT				WT. KG.
											d D	l E	t GA	u F	d1 DA	l1 FA	t1 GC	u1 GA	
GK1303		440	572	736	858	132	173	329	139	109	48	110	51,5	14	42	110	45	12	142
GK1305		490	603	767	890	132	173	329	139	91	48	110	51,5	14	42	110	45	12	154
GK1307		490	645	809	931	132	173	329	139	132	48	110	51,5	14	42	110	45	12	167
GK1309		540	676	840	963	132	173	329	139	114	48	110	51,5	14	42	110	45	12	179
GK1311		610	746	910	1033	132	173	329	139	114	48	110	51,5	14	42	110	45	12	204

TYPE	DIN IEC	amps	x1	g1	CONDUIT SIZE
GK1303		100	238	409	Pg29, Pg16
GK1303		200	225	423	Pg36, Pg16

TYPE	DIN IEC	amps	x1	g1	CONDUIT SIZE
GK1305		100	270	409	Pg29, Pg16
GK1305		200	257	423	Pg36, Pg16

TYPE	DIN IEC	amps	g1	CONDUIT SIZE	
GK1307		100	311	409	Pg29, Pg16
GK1307		200	298	423	Pg36, Pg16

TYPE	DIN IEC	amps	x1	g1	CONDUIT size
GK1309		100	343	409	Pg29, Pg16
GK1309		200	330	423	Pg36, Pg16

TYPE	DIN IEC	amps	x1	g1	CONDUIT size
GK1311		100	412	409	Pg29, Pg16
GK1311		200	400	423	Pg36, Pg16

- (1) "h" Dimension Will Not Be Exceeded. Shims Up To .5 mm In Thickness Are Usually Required For Coupled Or Geared Machines.
- (2) Shaft Extensions Are According To DIN 746. Tolerances Are Based On The ISA-Fitting System Using k6 For Diameters Up To 50 mm and m6 For Diameters Above.
- (3) The Terminal Box Size Varies With Horsepower And Voltage.
- (4) The Terminal Box Can Be Placed On The Right Or Left, Dimensions Remain The Same.
- (5) Tolerance Of Dimensions Are According To DIN.
- (6) Opposite Drive End Shaft Supplied Only When Specified.

Terminal Box Can Be Rotated For Lead Outlet At Top, Sides Or Bottom.  
Terminal Box Located On Opposite Side When F-1, W-2, W-3, W-6, W-8, Or C-2 Mounting Is Specified. Box Located On Top When Specified.  
Blower Assembly Can Be Located At Positions 1, 2, Or 4, Except

Blower Assembly And Terminal Box Can Not Be Located At The Same Position.  
Motor Weight May Vary 15% For Non-Standard Ratings And/Or Accessories.  
If Mounting Clearance Details Are Required, Consult Factory.

**Industrial Direct Current Motors and Generators – RPM III**

**ENCLOSURE:** Drip-Proof IP23  
**METHOD OF DRIVE:** Coupled or Belted

**COOLING:** Separate Ventilated IC17  
**MOUNTING:** Foot

**IEC TYPES GK1606 THRU GK1610**

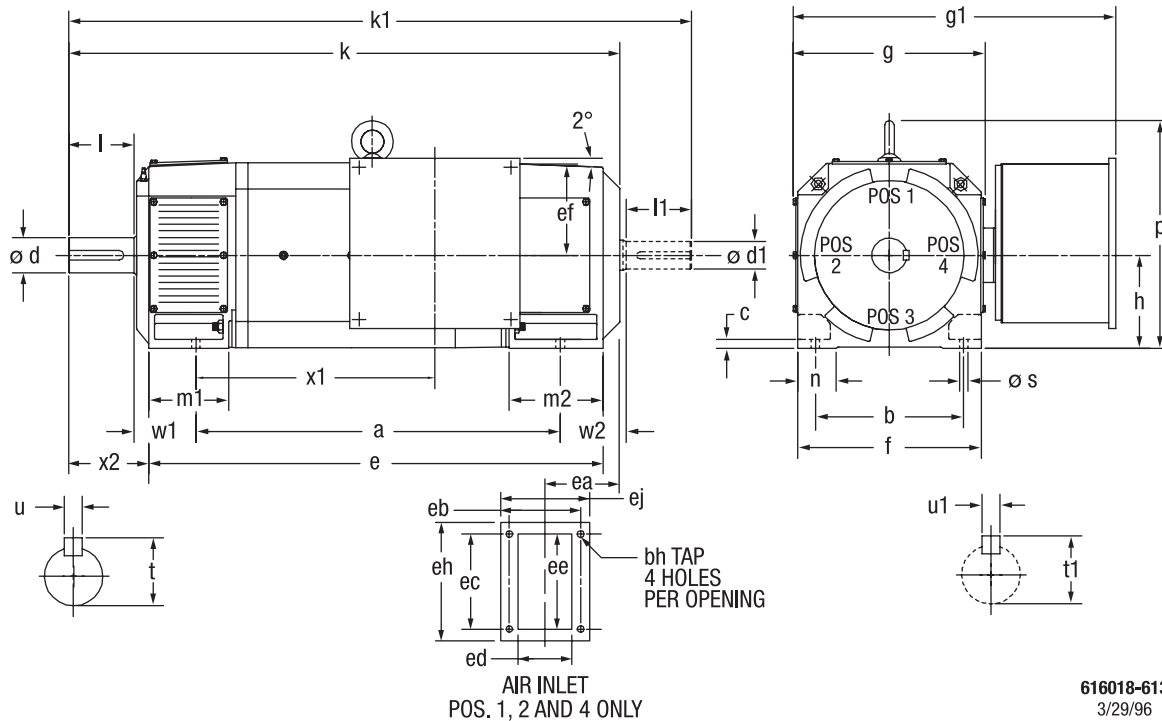

616018-613  
3/29/96

TYPE	DIN IEC	b A	c HA	f AB	g AC	h H	n AA	s K	w1 C	ea --	eb --	ec --	ed --	ee --	ef --	eh --	ej --	bh --
GK1606-GK1610		254	12	314	332	160	55	15	108	145	165	178	149	178	157	194	181	M8-1.25

TYPE	DIN IEC	a B	e BB	k L	k1 LC	m1 BA	m2 --	p HD	x2 --	w2 --	DRIVE END SHAFT				OPPOSITE DRIVE END SHAFT				WT. KG.
											d D	l E	t GA	u F	d1 DA	l1 EA	t1 GC	u1 FA	
GK1606		550	713	913	1036	154	203	398	172	128	60	140	64	18	48	110	51,5	14	263
GK1608		630	795	996	1119	154	203	398	172	126	60	140	64	18	48	110	51,5	14	302
GK1610		720	897	1098	1220	154	203	398	172	142	60	140	64	18	48	110	51,5	14	352

TYPE	DIN IEC	amps	x1 --	g1 --	CONDUIT SIZE
GK1606		100	334	453	Pg29, Pg16
GK1606		200	322	467	Pg36, Pg16
GK1606		400	339	560	(2)
GK1606		800	288	610	(2)

TYPE	DIN IEC	amps	x1 --	g1 --	CONDUIT SIZE
GK1608		100	416	453	Pg29, Pg16
GK1608		200	404	467	Pg36, Pg16
GK1608		400	421	560	(2)
GK1608		800	370	610	(2)

TYPE	DIN IEC	amps	x1 --	g1 --	CONDUIT SIZE
GK1610		100	518	453	Pg29, Pg16
GK1610		200	506	467	Pg36 Pg16
GK1610		400	523	560	(2)
GK1610		800	472	610	(2)

- (1) "h" Dimension Will Not Be Exceeded. Shims Up To .5 mm In Thickness Are Usually Required For Coupled Or Geared Machines.
- (2) Motor normally shipped with undrilled cable entry when over 200 amps
- (3) Shaft Extensions Are According To DIN 746. Tolerances Are Based On The ISA-Fitting System Using k6 For Diameters Up To 50 mm And m6 For Diameters Above.
- (4) The Terminal Box Size Varies With Horsepower And Voltage.
- (5) The Terminal Box Can Be Placed On The Right Or Left, Dimensions Remain The Same.
- (6) Tolerance Of Dimensions Are According To DIN.
- (7) Tolerance for Flanges according to DIN 42948

Terminal Box Can Be Rotated For Lead Outlet At Top, Sides Or Bottom.  
Terminal Box Located On Opposite Side When F-1, W-2, W-3, W-6, W-8, Or C-2 Mounting Is Specified. Box Located On Top When Specified.  
Blower Assembly Can Be Located At Positions 1, 2, Or 4, Except Blower Assembly And Terminal Box Can Not Be Located At The Same Position.  
Motor Weight May Vary 15% For Non-Standard Ratings And/Or Accessories.  
If Mounting Clearance Details Are Required, Consult Factory.

**Industrial Direct Current Motors and Generators – RPM III**

**ENCLOSURE:** Drip-Proof IP23  
**METHOD OF DRIVE:** Coupled or Belted

**COOLING:** Separate Ventilated IC17  
**MOUNTING:** Foot

**IEC TYPES GK1808 THRU UGK1810**

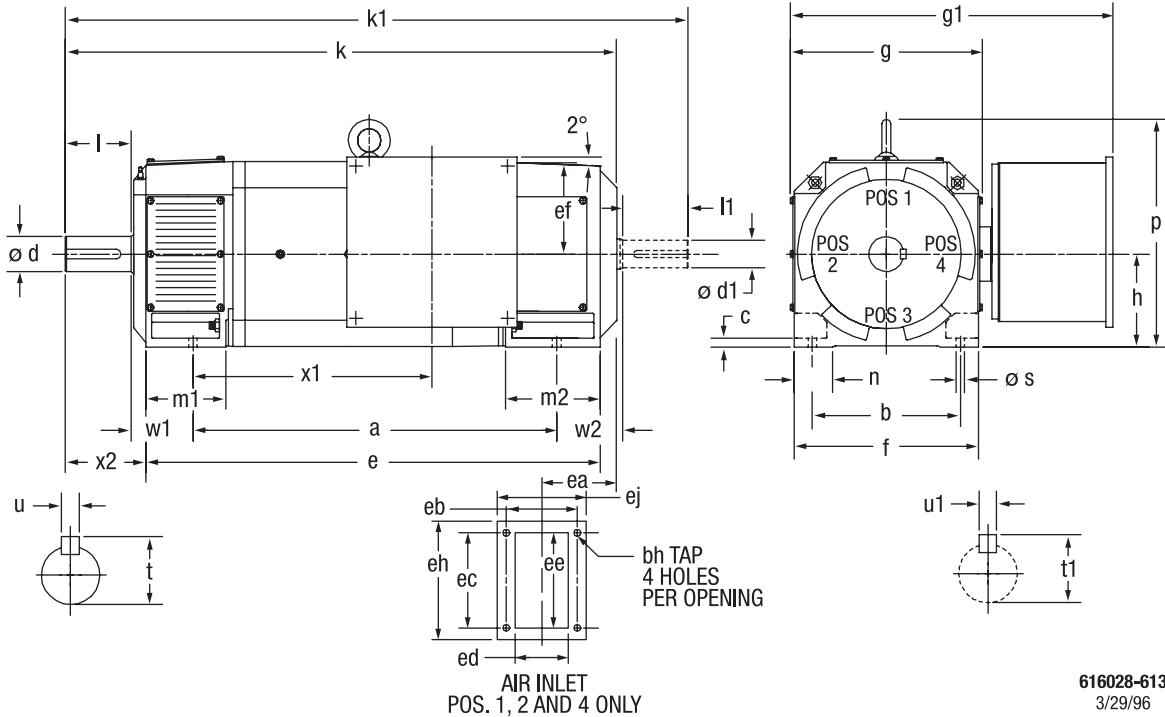

TYPE	DIN IEC	b A	c HA	f AB	g AC	h H	n AA	p HD	s K	w1 C	ea --	eb --	ec --	ed --	ee --	ef --	eh --	ej --	bh --
GK1808-GK1810		279	17	358	364	180	75	444	15	121	170	191	191	175	191	175	206	206	M8-1.25

TYPE	DIN IEC	a B	e BB	k L	k1 LC	m1 BA	m2 --	x2 --	w2 --	DRIVE END SHAFT				OPPOSITE DRIVE END SHAFT				WT. KG.
										d D	l E	t GA	u F	d1 DA	l1 EA	t1 GC	u1 FA	
(U)GK1808		710	860	1068	1190	172	234	170	109	70	140	74,5	20	48	110	51,5	14	411
(U)GK1810		790	999	1207	1330	172	234	170	168	70	140	74,5	20	48	110	51,5	14	495

TYPE	DIN IEC	amps	x1 --	g1 --	CONDUIT SIZE
(U)GK1808		200	406	502	Pg36, Pg16
(U)GK1808		400	428	596	(2)
(U)GK1808		800	377	646	(2)
(U)GK1808		1600	352	646	(2)

TYPE	DIN IEC	amps	x1 --	g1 --	CONDUIT SIZE
(U)GK1808		200	546	502	Pg36, Pg16
(U)GK1808		400	568	596	(2)
(U)GK1808		800	517	646	(2)
(U)GK1808		1600	492	646	(2)

- (1) "h" Dimension Will Not Be Exceeded. Shims Up To .5 mm In Thickness Are Usually Required For Coupled Or Geared Machines.
- (2) Motor normally shipped with undrilled cable entry when over 200 amps
- (3) Shaft Extensions Are According To DIN 746. Tolerances Are Based On The ISA-Fitting System Using k6 For Diameters Up To 50 mm And m6 For Diameters Above.
- (4) The Terminal Box Size Varies With Horsepower And Voltage.
- (5) The Terminal Box Can Be Placed On The Right Or Left, Dimensions Remain The Same.
- (6) Tolerance Of Dimensions Are According To DIN.
- (7) Opposite Drive End Shaft Supplied Only When Specified

Terminal Box Can Be Rotated For Lead Outlet At Top, Sides Or Bottom.  
Terminal Box Located On Opposite Side When F-1, W-2, W-3, W-6, W-8,  
Or C-2 Mounting Is Specified. Box Located On Top When Specified.  
Blower Assembly Can Be Located At Positions 1, 2, Or 4, Except  
Blower Assembly And Terminal Box Can Not Be Located At The Same Position.  
Motor Weight May Vary 15% For Non-Standard Ratings And/Or Accessories.  
If Mounting Clearance Details Are Required, Consult Factory.

**Industrial Direct Current Motors and Generators – RPM III**

**ENCLOSURE:** Drip-Proof IP23  
**METHOD OF DRIVE:** Coupled or Belted

**COOLING:** Separate Ventilated IC17  
**MOUNTING:** Foot

**IEC TYPES GK2008 THRU ULGK2010**

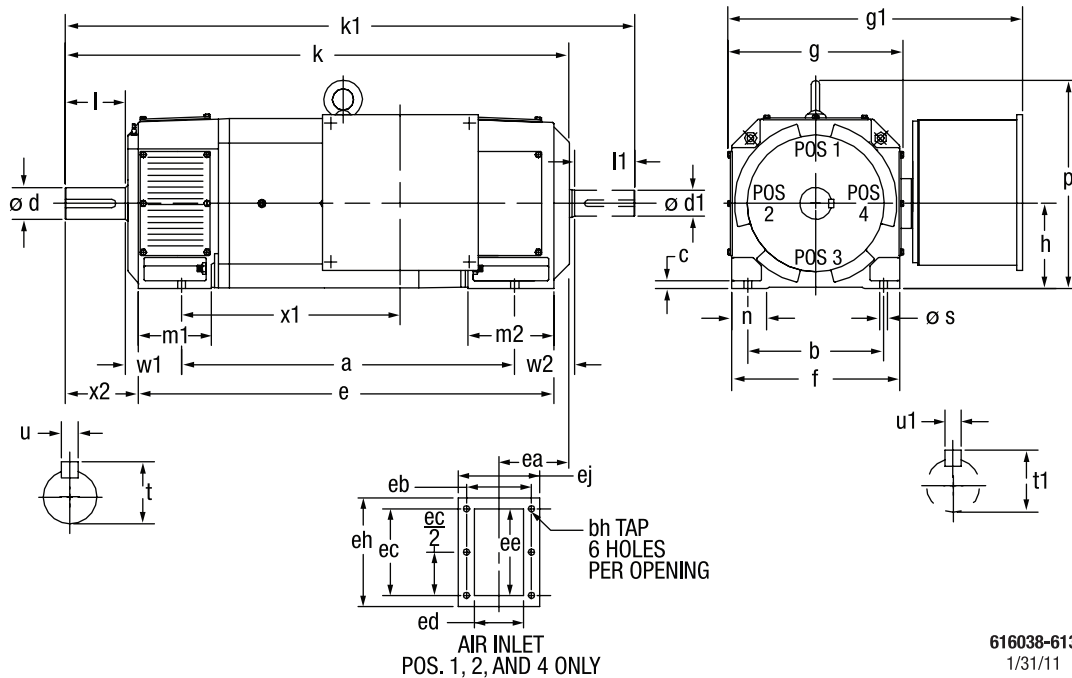

TYPE	DIN IEC	b A	c HA	f AB	g AC	h H	n AA	p HD	s K	w1 C	eb	ec	ed	ee	ef	eh	ej	bh
GK2008-ULGK2010		318	18	396	418	200	80	488	19	133	162	229	143	229	197	244	178	M8-1.25

TYPE	DIN IEC	a B	e BB	k L	k1 LC	m1 BA	m2	x2	w2	ea	DRIVE END SHAFT				OPPOSITE DRIVE END SHAFT				WT. KG.
											d D	l E	t GA	u F	d1 DA	l1 EA	t1 GC	u1 FA	
(U)GK2008		780	974	1182	1335	172	202	172	141	154	75	140	79,5	20	60	140	64	18	655
(U)LGK2008		780	1038	1245	1398	172	265	172	205	217	75	140	79,5	20	60	140	64	18	655
(U)GK2010		900	1050	1258	1411	172	202	172	97	154	75	140	79,5	20	60	140	64	18	707
(U)LGK2010		900	1114	1321	1474	172	265	172	161	217	75	140	79,5	20	60	140	64	18	707

TYPE	DIN IEC	amps	x1	g1
(U)(L)GK2008		400	563	642
(U)(L)GK2008		800	512	692
(U)(L)GK2008		1600	487	692

TYPE	DIN IEC	amps	x1	g1
(U)(L)GK2010		400	639	642
(U)(L)GK2010		800	588	692
(U)(L)GK2010		1600	563	692

- (1) "h" Dimension Will Not Be Exceeded. Shims Up To .5 mm In Thickness Are Usually Required For Coupled Or Geared Machines.
- (2) Motor normally shipped with undrilled cable entry when over 200 amps
- (3) Shaft Extensions Are According To DIN 746. Tolerances Are Based On The ISA-Fitting System Using k6 For Diameters Up To 50 mm And m6 For Diameters Above.
- (4) The Terminal Box Size Varies With Horsepower And Voltage.
- (5) The Terminal Box Can Be Placed On The Right Or Left, Dimensions Remain The Same.
- (6) Tolerance Of Dimensions Are According To DIN.
- (7) Opposite Drive End Shaft Supplied Only When Specified

Terminal Box Can Be Rotated For Lead Outlet At Top, Sides Or Bottom.  
Terminal Box Located On Opposite Side When F-1, W-2, W-3, W-6, W-8,  
Or C-2 Mounting Is Specified. Box Located On Top When Specified.  
Blower Assembly Can Be Located At Positions 1, 2, Or 4, Except  
Blower Assembly And Terminal Box Can Not Be Located At The Same Position.  
Motor Weight May Vary 15% For Non-Standard Ratings And/Or Accessories.  
If Mounting Clearance Details Are Required, Consult Factory.

# Industrial Direct Current Motors and Generators – RPM III

**ENCLOSURE:** Drip-Proof IP23  
**METHOD OF DRIVE:** Coupled or Belted

**COOLING:** Separate Ventilated IC17  
**MOUNTING:** Foot

## IEC TYPES GK2208 THRU ULGK2210

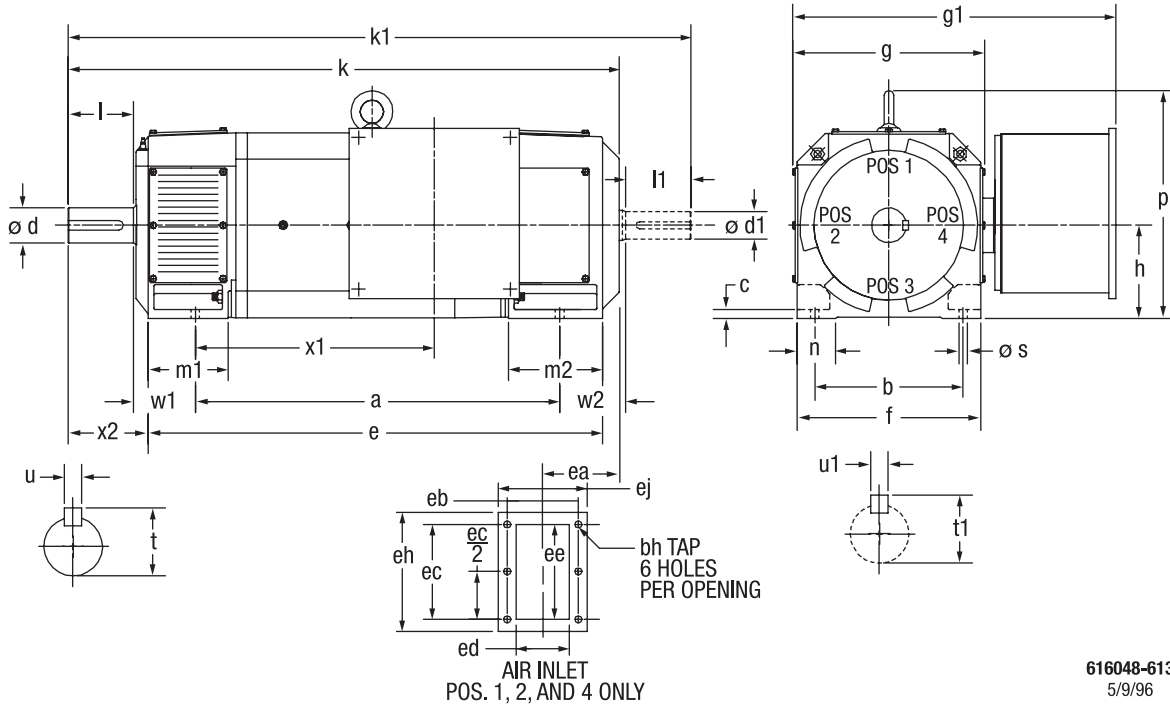

616048-613  
5/9/96

TYPE	DIN IEC	b A	c HA	f AB	g AC	g2 —	h H	n AA	p HD	s K	w1 C	eb —	ec —	ed —	ee —	ef —	eh —	ej —	bh —
GK2208-ULGK2210		356	18	446	468	280	225	85	538	19	149	181	254	162	254	222	270	197	M8-1.25

TYPE	DIN IEC	a B	e BB	k L	k1 LC	m1 BA	m2 —	x —	ea —	w2 CA	DRIVE END SHAFT				OPPOSITE DRIVE END SHAFT				WT. KG.
											d D	l E	t GA	u F	d1 DA	l1 EA	t1 GC	u1 FA	
(U)GK2208		840	1060	1303	1456	184	217	205	165	101	80	170	85	22	65	140	69	18	897
(U)LGK2208		840	1104	1348	1501	184	262	161	210	145	80	170	85	22	65	140	69	18	897
(U)GK2210		960	1123	1367	1520	184	217	205	165	101	80	170	85	22	65	140	69	18	947
(U)LGK2210		960	1168	1412	1565	184	262	161	210	145	80	170	85	22	65	140	69	18	947

TYPE	DIN IEC	amps	x1 —	g1 —
(U)(L)GK2208		400	619	692
(U)(L)GK2208		800	569	742
(U)(L)GK2208		1600	543	742

TYPE	DIN IEC	amps	x1 —	g1 —
(U)(L)GK2210		400	683	692
(U)(L)GK2210		800	633	742
(U)(L)GK2210		1600	607	742

- (1) "h" Dimension Will Not Be Exceeded. Shims Up To .5 mm In Thickness Are Usually Required For Coupled Or Geared Machines.
- (2) Motor normally shipped with undrilled cable entry when over 200 amps
- (3) Shaft Extensions Are According To DIN 746. Tolerances Are Based On The ISA-Fitting System Using k6 For Diameters Up To 50 mm And m6 For Diameters Above.
- (4) The Terminal Box Size Varies With Horsepower And Voltage.
- (5) The Terminal Box Can Be Placed On The Right Or Left, Dimensions Remain The Same.
- (6) Tolerance Of Dimensions Are According To DIN.
- (7) opposite drive end shaft supplied only when specified

Terminal Box Can Be Rotated For Lead Outlet At Top, Sides Or Bottom.  
Terminal Box Located On Opposite Side When F-1, W-2, W-3, W-6, W-8,  
Or C-2 Mounting Is Specified. Box Located On Top When Specified.  
Blower Assembly Can Be Located At Positions 1, 2, Or 4, Except  
Blower Assembly And Terminal Box Can Not Be Located At The Same Position.  
Motor Weight May Vary 15% For Non-Standard Ratings And/Or Accessories.  
If Mounting Clearance Details Are Required, Consult Factory.



# Industrial Direct Current Motors and Generators – RPM III

**ENCLOSURE:** Drip-Proof IP23  
**METHOD OF DRIVE:** Coupled or Belted

**COOLING:** Separate Ventilated IC17  
**MOUNTING:** Foot

## IEC TYPES GK2508 THRU UGK2510

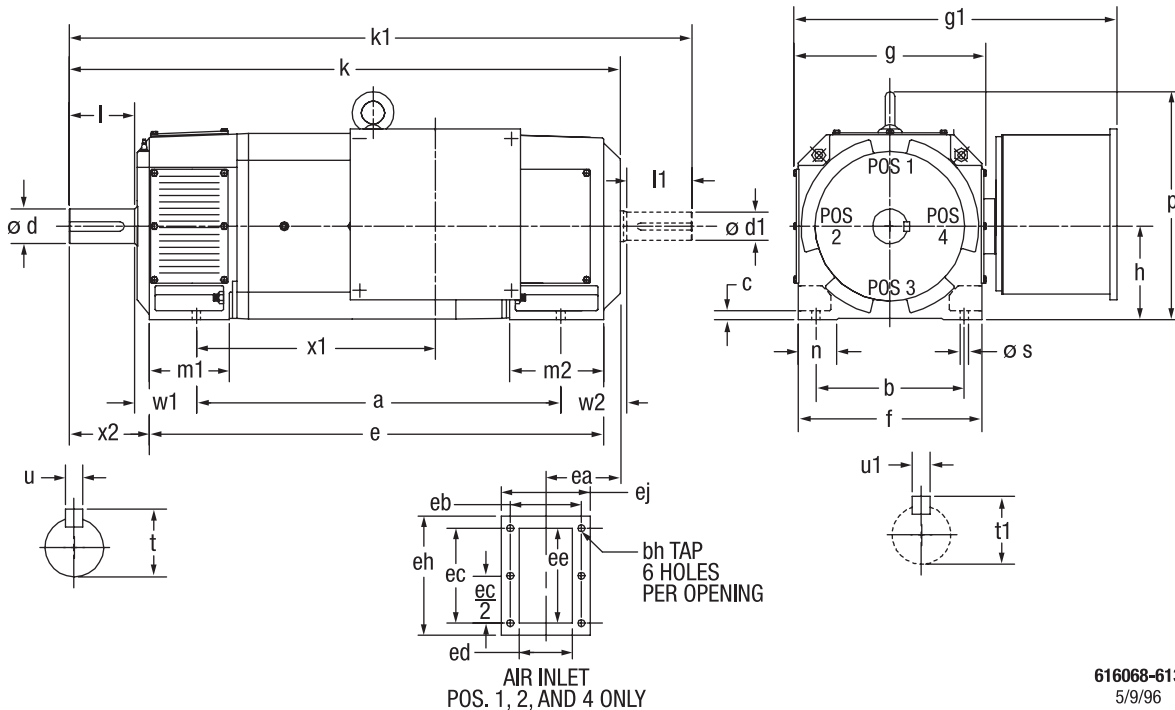

616068-613  
5/9/96

TYPE	DIN IEC	b A	c HA	f AB	g AC	h H	n AA	s K	w1 C	ea	eb	ec	ed	ee	ef	eh	ej	bh
GK2508-UGK2510		406	22	495	510	250	90	24	168	234	222	286	203	267	246	306	242	M8-1.25

TYPE	DIN IEC	a B	e BB	g2	k L	k1 LC	m1 BA	m2	p HD	x2	w2 CA	DRIVE END SHAFT				OPPOSITE DRIVE END SHAFT				WT. KG.
												d D	l E	t GA	u F	d1 DA	l1 EA	t1 GC	u1 FA	
(U)GK2508		900	1190	280	1433	1590	222	310	608	209	211	90	170	95	25	75	140	79,5	20	1246
(U)GK2510		1030	1335	313	1580	1735	222	310	608	209	228	90	170	95	25	75	140	79,5	20	1459

TYPE	DIN IEC	amps	x1	g1
(U)GK2508		400	563	757
(U)GK2508		800	588	807
(U)GK2508		1600	639	807

TYPE	DIN IEC	amps	x1	g1
(U)GK2510		400	709	757
(U)GK2510		800	734	807
(U)GK2510		1600	758	807

- "h" Dimension Will Not Be Exceeded. Shims Up To .5 mm In Thickness Are Usually Required For Coupled Or Geared Machines.
- Motor normally shipped with undrilled cable entry when over 200 amps
- Shaft Extensions Are According To DIN 746. Tolerances Are Based On The ISA-Fitting System Using k6 For Diameters Up To 50 mm And m6 For Diameters Above.
- The Terminal Box Size Varies With Horsepower And Voltage.
- The Terminal Box Can Be Placed On The Right Or Left, Dimensions Remain The Same.
- Tolerance Of Dimensions Are According To DIN.
- Opposite Drive End Shaft Supplied Only When Specified.

Terminal Box Can Be Rotated For Lead Outlet At Top, Sides Or Bottom.  
Terminal Box Located On Opposite Side When F-1, W-2, W-3, W-6, W-8,  
Or C-2 Mounting Is Specified. Box Located On Top When Specified.  
Blower Assembly Can Be Located At Positions 1, 2, Or 4, Except  
Blower Assembly And Terminal Box Can Not Be Located At The Same Position.  
Motor Weight May Vary 15% For Non-Standard Ratings And/Or Accessories.  
If Mounting Clearance Details Are Required, Consult Factory.

# Industrial Direct Current Motors and Generators – RPM III

**ENCLOSURE:** Drip-Proof IP23, Pipe-Ventilated  
**MOUNTING:** Foot

**COOLING:** Separately, Force Ventilated IC17

## IEC FRAME GK2806 THRU GK2810

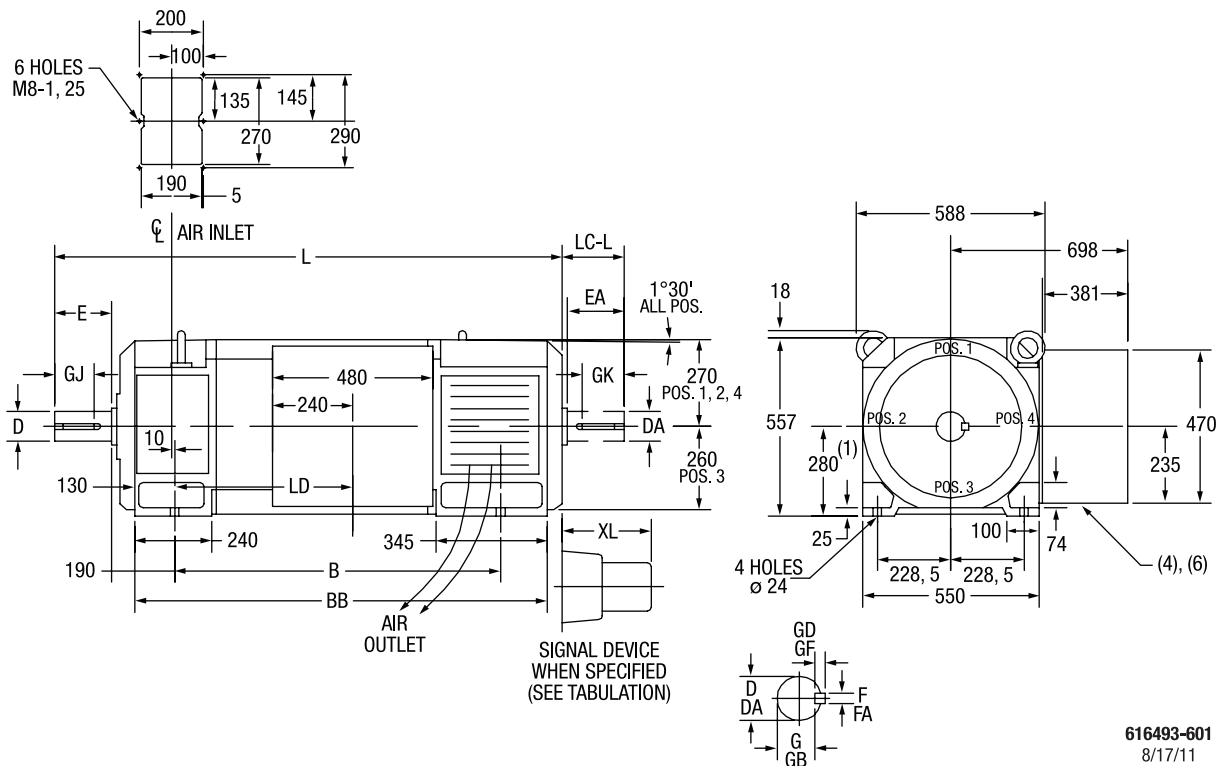

616493-601  
8/17/11

DIMENSIONS ARE IN MILLIMETERS

FRAME	L	LD	BB	B	DRIVE END SHAFT AND KEY						<sup>(5)</sup> OPPOSITE DRIVE END SHAFT AND KEY						WT. (KG.)	
					D <sup>(2)</sup>	E	F	G <sup>(3)</sup>	GD	GJ	LC-L	DA <sup>(2)</sup>	EA	FA	GB <sup>(3)</sup>	GF		GK
GK2806	1507	503	1184	900	100	210	28	90	16	165	180	80	170	22	71	14	154	1394
UGK2806	1507	503	1184	900	110	210	28	90	16	165	180	80	170	22	71	14	154	1394
GK2808	1607	603	1284	1000	100	210	28	90	16	165	180	80	170	22	71	14	154	1583
UGK2808	1607	603	1284	1000	110	210	28	90	16	165	180	80	170	22	71	14	154	1583
GK2810	1767	763	1444	1160	100	210	28	90	16	165	180	80	170	22	71	14	154	1864
UGK2810	1767	763	1444	1160	110	210	28	90	16	165	180	80	170	22	71	14	154	1864

SIGNAL DEVICE	XL	WT. (KG.)
5PY	276	3,2
BC-42	340	11,4
BC46	398	15,9
M-627A	267	6,4
M-628A	267	6,4
M-727A	267	6,4

SIGNAL DEVICE	XL	WT. (KG.)
M-737A	267	6,4
RD-11	254	7,7
RD-51	424	17,2
RD-61	254	7,7
RD-62	254	7,7
RD-045	65	2,3

SIGNAL DEVICE	XL	WT. (KG.)
RE-210	389	13,6
TG2168A	65	2,3
TS2014N	165	2,3
TS2087N	279	6,4
AVTRON M3	102	6,4

- (1) This Dimension Will Not Be Exceeded. Shims Up To 1,5mm In Thickness Are Usually Required For Coupled Or Geared Machines.
- (2) "D" And "DA" Vary -0,025
- (3) "G" And "GB" Vary -0,38
- (4) Removable Cover Plate For Customer Drilling. Terminal Box Can Be Positioned For Either Top Or Bottom Conduit Entry
- (5) Opposite Drive End Shaft Supplied Only When Specified
- (6) Terminal Box Located On Opposite Side When Specified

# Industrial Direct Current Motors and Generators – RPM III

**ENCLOSURE:** Drip-Proof IP23

**COOLING:** Force Ventilated IC06, Air Filtered

**METHOD OF DRIVE:** Coupled or Belted

**MOUNTING:** Foot

## IEC TYPES GK1104 THRU GK1110

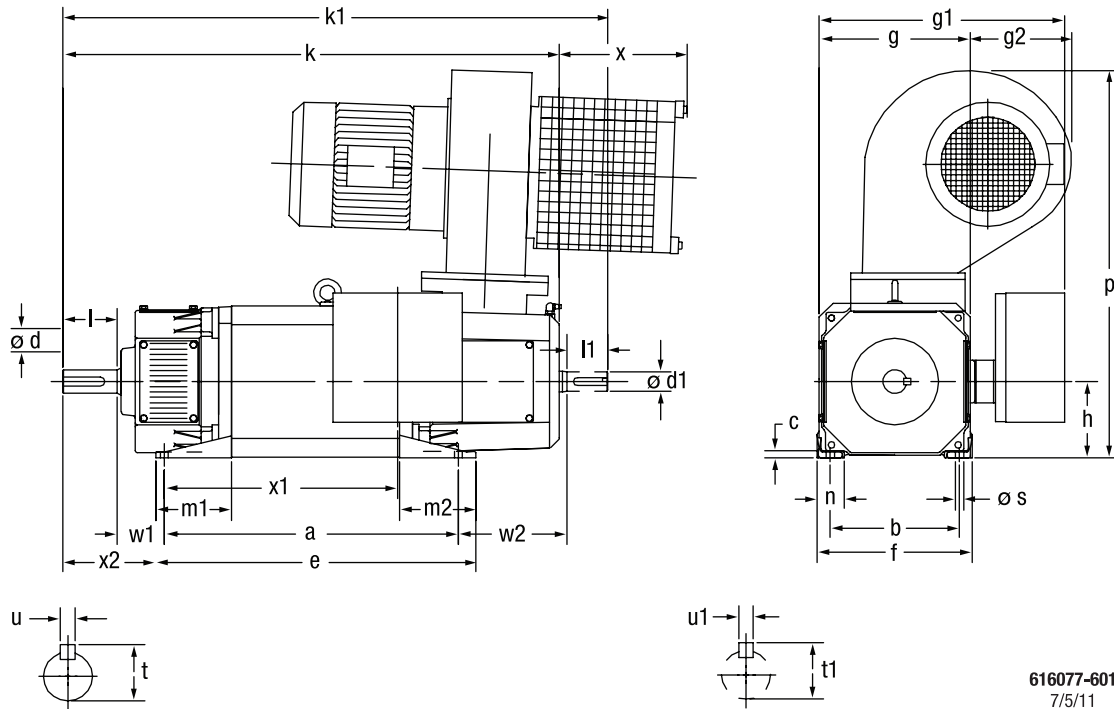

616077-601  
7/5/11

TYPE	DIN IEC	b A	c HA	f AB	g AC	g2 —	h H	n AA	p HD	s K	w1 C
GK1104-GK1110		190	6	229	222	260	112	35	578	12	70

TYPE	DIN IEC	a B	e BB	k L	k1 LC	m1 BA	m2 —	x —	x2 —	w2 CA	DRIVE END SHAFT				OPPOSITE DRIVE END SHAFT				WT. KG.
											d D	l E	t GA	u F	d1 DA	l1 EA	t1 GC	u1 FA	
GK1104		318	356	616	688	111	111	205	137	160	38	80	41	10	28	60	31	8	84
GK1106		356	394	655	726	111	111	205	137	160	38	80	41	10	28	60	31	8	93
GK1108		406	445	705	776	111	111	205	137	160	38	80	41	10	28	60	31	8	111
GK1110		432	471	731	802	111	111	205	137	160	38	80	41	10	28	60	31	8	120

TYPE	DIN IEC	amps	x1 —	g1 —	CONDUIT SIZE
GK1104		100	228	361	Pg29,Pg16
GK1108		100	317	361	Pg29,Pg16

TYPE	DIN IEC	amps	x1 —	g1 —	CONDUIT SIZE
GK1106		100	266	361	Pg29,Pg16
GK1110		100	343	361	Pg29,Pg16

- (1) "h" Dimension Will Not Be Exceeded. Shims Up To .5 mm In Thickness Are Usually Required For Coupled Or Geared Machines.
- (2) Shaft Extensions Are According To DIN 746. Tolerances Are Based On The ISA-Fitting System Using k6 For Diameters Up To 50 mm And m6 For Diameters Above.
- (3) The Terminal Box Size Varies With Horsepower And Voltage.
- (4) The Terminal Box Can Be Placed On The Right Or Left, Dimensions Remain The Same.
- (5) Tolerance Of Dimensions Are According To DIN.
- (6) Opposite Drive End Shaft Supplied Only When Specified.

Terminal Box Can Be Rotated For Lead Outlet At Top, Sides Or Bottom.  
Terminal Box Located On Opposite Side When F-1, W-2, W-3, W-6, W-8,  
Or C-2 Mounting Is Specified. Box Located On Top When Specified.  
Blower Assembly Can Be Located At Positions 1, 2, Or 4, Except  
Blower Assembly And Terminal Box Can Not Be Located At The Same Position.  
Motor Weight May Vary 15% For Non-Standard Ratings And/Or Accessories.  
If Mounting Clearance Details Are Required, Consult Factory.

# Industrial Direct Current Motors and Generators – RPM III

**ENCLOSURE:** Drip-Proof IP23  
**METHOD OF DRIVE:** Coupled or Belted

**COOLING:** Force Ventilated IC06, Air Filtered  
**MOUNTING:** Foot

## IEC TYPES GK1303 THRU GK1311

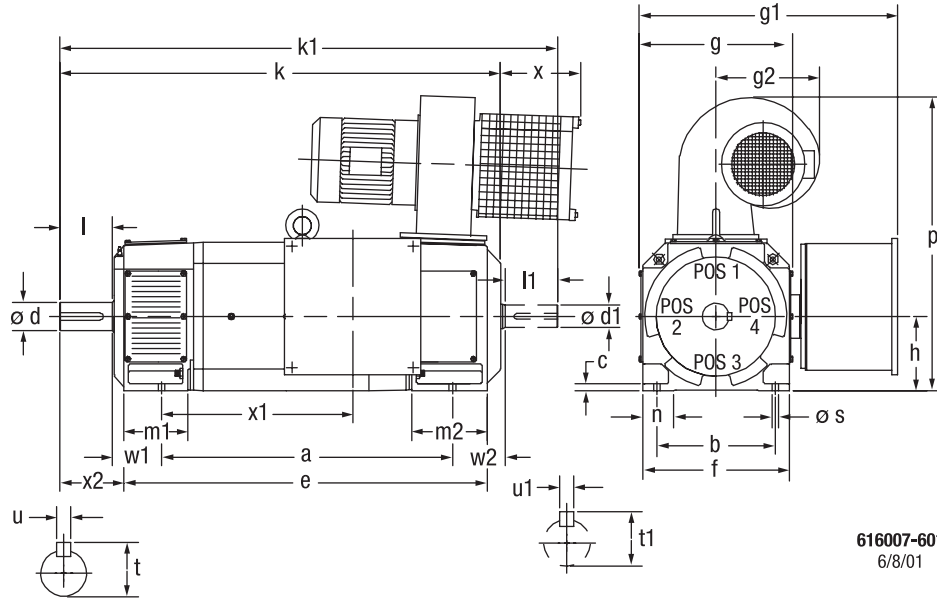

TYPE	DIN IEC	b A	c HA	f AB	g AC	h H	n AA	s K	w1 C
GK1303-GK1311		440	572	254	736	858	132	173	578

TYPE	DIN IEC	a B	e BB	g2	k L	k1 IC	m1 BA	m2	p HD	x2	x2	w2 CA	DRIVE END SHAFT				OPPOSITE DRIVE END SHAFT				WT. KG.
													d D	l E	t GA	u F	d1 DA	l1 FA	t1 GC	u1 FA	
GK1303		440	572	254	736	858	132	173	578	197	139	109	48	110	51,5	14	42	110	45	12	154
GK1305		490	603	254	767	890	132	173	578	197	139	91	48	110	51,5	14	42	110	45	12	166
GK1307		490	645	254	809	931	132	173	578	197	139	132	48	110	51,5	14	42	110	45	12	179
GK1309		540	676	254	840	963	132	173	578	197	139	114	48	110	51,5	14	42	110	45	12	191
GK1311		610	746	254	910	1033	132	173	578	197	139	114	48	110	51,5	14	42	110	45	12	215

TYPE	DIN IEC	amps	x1	g1	CONDUIT SIZE
GK1303		100	238	409	Pg29, Pg16
GK1303		200	225	423	Pg36, Pg16

TYPE	DIN IEC	amps	x1	g1	CONDUIT SIZE
GK1305		100	270	409	Pg29, Pg16
GK1305		200	257	423	Pg36, Pg16

TYPE	DIN IEC	amps	x1	g1	CONDUIT SIZE
GK1307		100	311	409	Pg29, Pg16
GK1307		200	298	423	Pg36, Pg16

TYPE	DIN IEC	amps	x1	g1	CONDUIT size
GK1309		100	343	409	Pg29, Pg16
GK1309		200	330	423	Pg36, Pg16

TYPE	DIN IEC	amps	x1	g1	CONDUIT size
GK1311		100	412	409	Pg29, Pg16
GK1311		200	400	423	Pg36, Pg16

- (1) "h" Dimension Will Not Be Exceeded. Shims Up To .5 mm In Thickness Are Usually Required For Coupled Or Geared Machines.
- (2) Shaft Extensions Are According To DIN 746. Tolerances Are Based On The ISA-Fitting System Using k6 For Diameters Up To 50 mm And m6 For Diameters Above.
- (3) The Terminal Box Size Varies With Horsepower And Voltage.
- (4) The Terminal Box Can Be Placed On The Right Or Left, Dimensions Remain The Same.
- (5) Tolerance Of Dimensions Are According To DIN.
- (6) Opposite Drive End Shaft Supplied Only When Specified.

Terminal Box Can Be Rotated For Lead Outlet At Top, Sides Or Bottom.  
Terminal Box Located On Opposite Side When F-1, W-2, W-3, W-6, W-8, Or C-2 Mounting Is Specified. Box Located On Top When Specified.  
Blower Assembly Can Be Located At Positions 1, 2, Or 4, Except Blower Assembly And Terminal Box Can Not Be Located At The Same Position.  
Motor Weight May Vary 15% For Non-Standard Ratings And/Or Accessories.  
If Mounting Clearance Details Are Required, Consult Factory.

**Industrial Direct Current Motors and Generators – RPM III**

**ENCLOSURE:** Drip-Proof IP23  
**METHOD OF DRIVE:** Coupled or Belted

**COOLING:** Force Ventilated IC06, Air Filtered  
**MOUNTING:** Foot

**IEC TYPES GK1606 THRU GK1610**

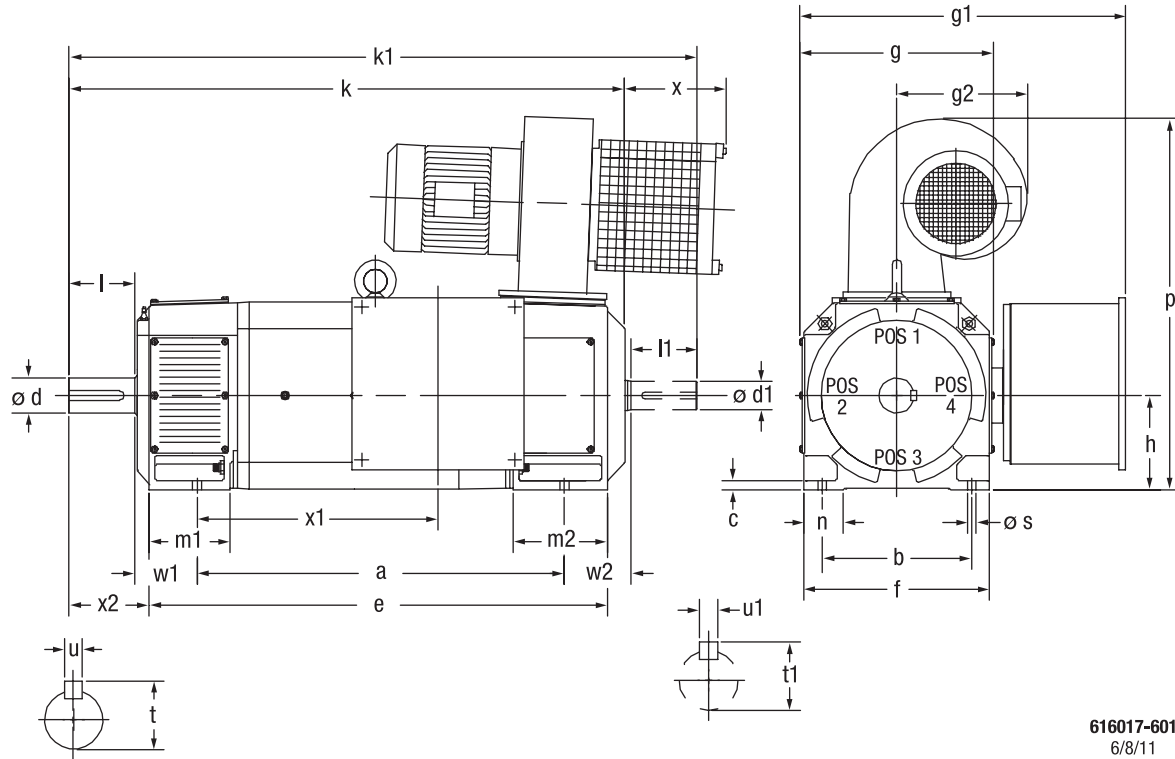

616017-601  
6/8/11

TYPE	DIN IEC	b A	c HA	f AB	g AC	h H	n AA	s K	w1 C
GK1606-GK1610		254	12	314	332	160	55	15	108

TYPE	DIN IEC	a B	e BB	g2	k L	k1 LC	m1 BA	m2	p HD	x	x2	w2 CA	DRIVE END SHAFT				OPPOSITE DRIVE END SHAFT				WT. KG.
													d D	l E	t GA	u F	d1 DA	l1 EA	t1 GC	u1 FA	
GK1606		550	713	242	913	1036	154	203	629	185	172	128	60	140	64	18	48	110	51,5	14	274
GK1608		630	795	242	996	1119	154	203	629	185	172	126	60	140	64	18	48	110	51,5	14	313
GK1610		720	897	242	1098	1220	154	203	629	185	172	142	60	140	64	18	48	110	51,5	14	363

TYPE	DIN IEC	amps	x1	g1	CONDUIT SIZE
GK1606		100	334	453	Pg29, Pg16
GK1606		200	322	467	Pg36, Pg16
GK1606		400	339	560	(2)
GK1606		800	288	610	(2)

TYPE	DIN IEC	amps	x1	g1	CONDUIT SIZE
GK1608		100	416	453	Pg29, Pg16
GK1608		200	404	467	Pg36, Pg16
GK1608		400	421	560	(2)
GK1608		800	370	610	(2)

TYPE	DIN IEC	amps	g1	CONDUIT SIZE
GK1610		100	518	453
GK1610		200	506	467
GK1610		400	523	560
GK1610		800	472	610

- (1) "h" Dimension Will Not Be Exceeded. Shims Up To .5 mm In Thickness Are Usually Required For Coupled Or Geared Machines.
- (2) Motor Normally Shipped With Undrilled Cable Entry When Over 200 Amps.
- (3) Shaft Extensions Are According To DIN 746. Tolerances Are Based On The ISA-Fitting System Using k6 For Diameters Up To 50 mm And m6 For Diameters Above.
- (4) The Terminal Box Size Varies With Horsepower And Voltage.
- (5) The Terminal Box Can Be Placed On The Right Or Left, Dimensions Remain The Same.
- (6) Tolerance Of Dimensions Are According To DIN.
- (7) Opposite Drive End Shaft Supplied Only When Specified.

Terminal Box Can Be Rotated For Lead Outlet At Top, Sides Or Bottom.  
Terminal Box Located On Opposite Side When F-1, W-2, W-3, W-6, W-8,  
Or C-2 Mounting Is Specified. Box Located On Top When Specified.  
Blower Assembly Can Be Located At Positions 1, 2, Or 4, Except  
Blower Assembly And Terminal Box Can Not Be Located At The Same Position.  
Motor Weight May Vary 15% For Non-Standard Ratings And/Or Accessories.  
If Mounting Clearance Details Are Required, Consult Factory.

# Industrial Direct Current Motors and Generators – RPM III

**ENCLOSURE:** Drip-Proof IP23

**COOLING:** Force Ventilated IC06, Air Filtered

**METHOD OF DRIVE:** Coupled or Belted

**MOUNTING:** Foot

## IEC TYPES GK1808 THRU UGK1810

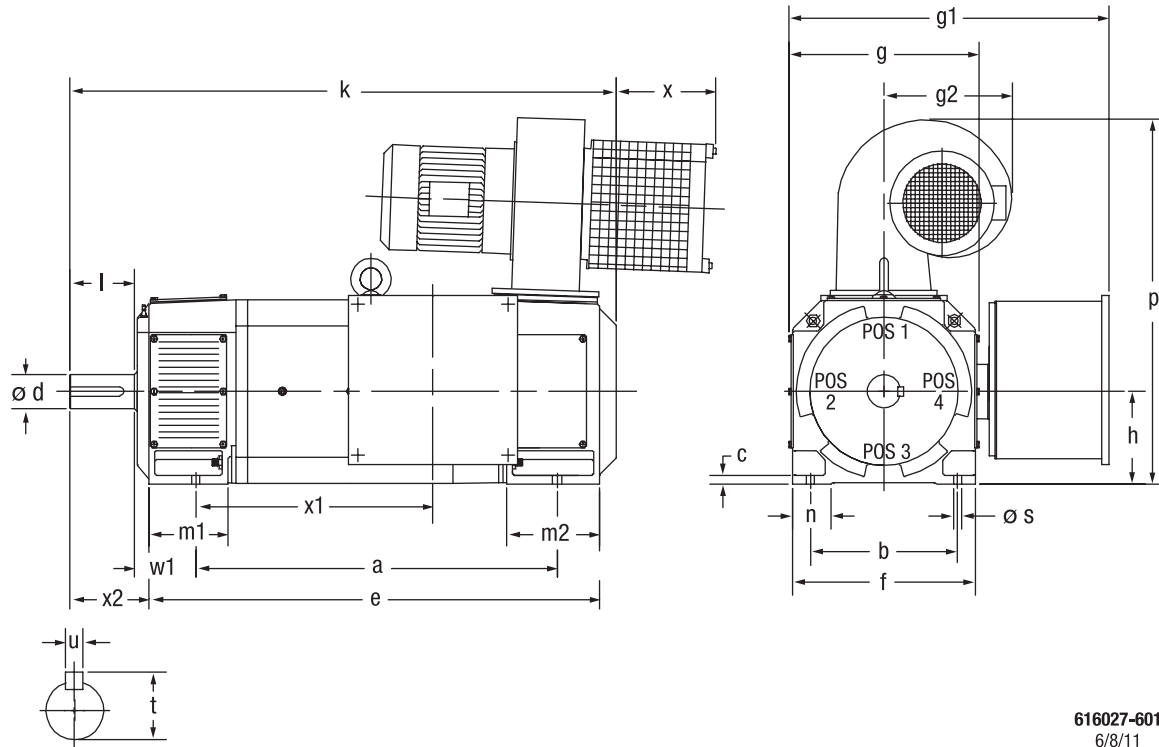

616027-601  
6/8/11

	DIN	b	c	f	g	g2	h	n	p	s	w1
TYPE	IEC	A	HA	AB	AC	—	H	AA	HD	K	C
GK1808-UGK1810		279	17	358	364	235	180	75	667	15	121

DIN TYPE	a	e	k	m1	m2	x	x2	w2	DRIVE END SHAFT				OPPOSITE DRIVE END SHAFT				WT. KG.
									d	l	t	u	d1	l1	t1	u1	
IEC	B	BB	L	BA	—	—	—	CA	D	E	GA	F	DA	EA	GC	FA	
(U)GK1808	710	860	1068	172	234	162	170	109	70	140	74,5	20	48	110	51,5	14	424
(U)GK1810	790	999	1207	172	234	162	170	168	70	140	74,5	20	48	110	51,5	14	508

DIN TYPE	IEC	amps	x1	g1	CONDUIT SIZE
(U)GK1808		200	406	502	Pg36, Pg16
(U)GK1808		400	428	596	(2)
(U)GK1808		800	377	646	(2)
(U)GK1808		1600	352	646	(2)

DIN TYPE	IEC	amps	x1	g1	CONDUIT SIZE
(U)GK1808		200	546	502	Pg36, Pg16
(U)GK1808		400	568	596	(2)
(U)GK1808		800	517	646	(2)
(U)GK1808		1600	492	646	(2)

- (1) "h" Dimension Will Not Be Exceeded. Shims Up To .5 mm In Thickness Are Usually Required For Coupled Or Geared Machines.
- (2) Motor normally shipped with undrilled cable entry when over 200 amps
- (3) Shaft Extensions Are According To DIN 746. Tolerances Are Based On The ISA-Fitting System Using k6 For Diameters Up To 50 mm And m6 For Diameters Above.
- (4) The Terminal Box Size Varies With Horsepower And Voltage.
- (5) The Terminal Box Can Be Placed On The Right Or Left, Dimensions Remain The Same.
- (6) Tolerance Of Dimensions Are According To DIN.
- (7) Opposite Drive End Shaft Supplied Only When Specified

Terminal Box Can Be Rotated For Lead Outlet At Top, Sides Or Bottom.  
Terminal Box Located On Opposite Side When F-1, W-2, W-3, W-6, W-8,  
Or C-2 Mounting Is Specified. Box Located On Top When Specified.  
Blower Assembly Can Be Located At Positions 1, 2, Or 4, Except  
Blower Assembly And Terminal Box Can Not Be Located At The Same Position.  
Motor Weight May Vary 15% For Non-Standard Ratings And/Or Accessories.  
If Mounting Clearance Details Are Required, Consult Factory.

# Industrial Direct Current Motors and Generators – RPM III

**ENCLOSURE:** Drip-Proof IP23  
**METHOD OF DRIVE:** Coupled or Belted

**COOLING:** Separate Ventilated IC06, Air Filtered  
**MOUNTING:** Foot

## IEC TYPES GK2008 THRU ULGK2010

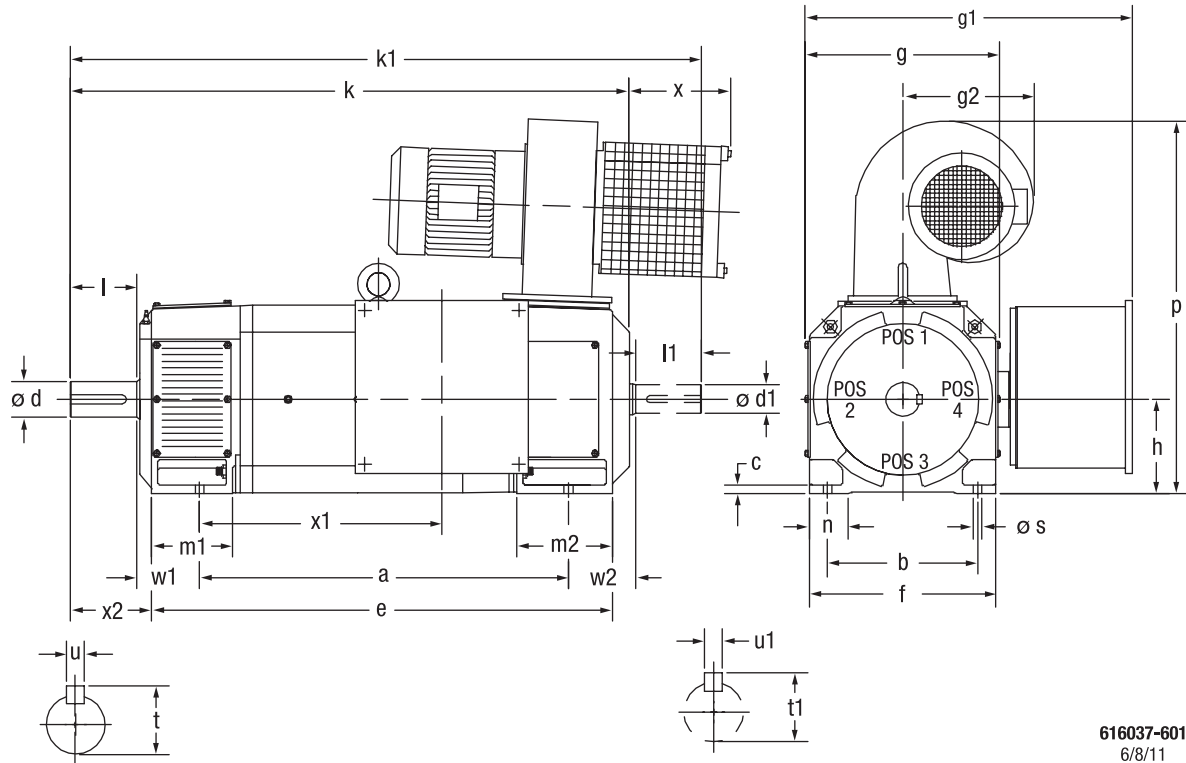

616037-601  
6/8/11

TYPE	DIN IEC	b A	c HA	f AB	g AC	g2 --	h H	n AA	p HD	s K	w1 C
GK2008-ULGK2010		318	18	396	418	216	200	80	711	19	133

TYPE	DIN IEC	a B	e BB	k L	k1 LC	m1 BA	m2 --	x --	x2 --	w2 CA	DRIVE END SHAFT				OPPOSITE DRIVE END SHAFT				WT. KG.
											d D	l E	t GA	u F	d1 DA	l1 EA	t1 GC	u1 FA	
(U)GK2008		780	974	1182	1335	172	202	172	172	141	75	140	79,5	20	60	140	64	18	665
(U)LGK2008		780	1038	1245	1398	172	265	172	172	205	75	140	79,5	20	60	140	64	18	665
(U)GK2010		900	1050	1258	1411	172	202	172	172	97	75	140	79,5	20	60	140	64	18	717
(U)LGK2010		900	1114	1321	1474	172	265	172	172	161	75	140	79,5	20	60	140	64	18	717

TYPE	DIN IEC	amps	x1	g1
(U)(L)GK2008		400	563	642
(U)(L)GK2008		800	512	692
(U)(L)GK2008		1600	487	692

TYPE	DIN IEC	amps	x1	g1
(U)(L)GK2010		400	639	642
(U)(L)GK2010		800	588	692
(U)(L)GK2010		1600	563	692

- (1) "h" Dimension Will Not Be Exceeded. Shims Up To .5 mm In Thickness Are Usually Required For Coupled Or Geared Machines.
- (2) Motor normally shipped with undrilled cable entry when over 200 amps
- (3) Shaft Extensions Are According To DIN 746. Tolerances Are Based On The ISA-Fitting System Using k6 For Diameters Up To 50 mm And m6 For Diameters Above.
- (4) The Terminal Box Size Varies With Horsepower And Voltage.
- (5) The Terminal Box Can Be Placed On The Right Or Left, Dimensions Remain The Same.
- (6) Tolerance Of Dimensions Are According To DIN.
- (7) Opposite Drive End Shaft Supplied Only When Specified

Terminal Box Can Be Rotated For Lead Outlet At Top, Sides Or Bottom.  
Terminal Box Located On Opposite Side When F-1, W-2, W-3, W-6, W-8, Or C-2 Mounting Is Specified. Box Located On Top When Specified.  
Blower Assembly Can Be Located At Positions 1, 2, Or 4, Except Blower Assembly And Terminal Box Can Not Be Located At The Same Position.  
Motor Weight May Vary 15% For Non-Standard Ratings And/Or Accessories.  
If Mounting Clearance Details Are Required, Consult Factory.

# Industrial Direct Current Motors and Generators – RPM III

**ENCLOSURE:** Drip-Proof IP23  
**METHOD OF DRIVE:** Coupled or Belted

**COOLING:** Force Ventilated IC06, Air Filtered  
**MOUNTING:** Foot

## IEC TYPES GK2208 THRU ULGK2210

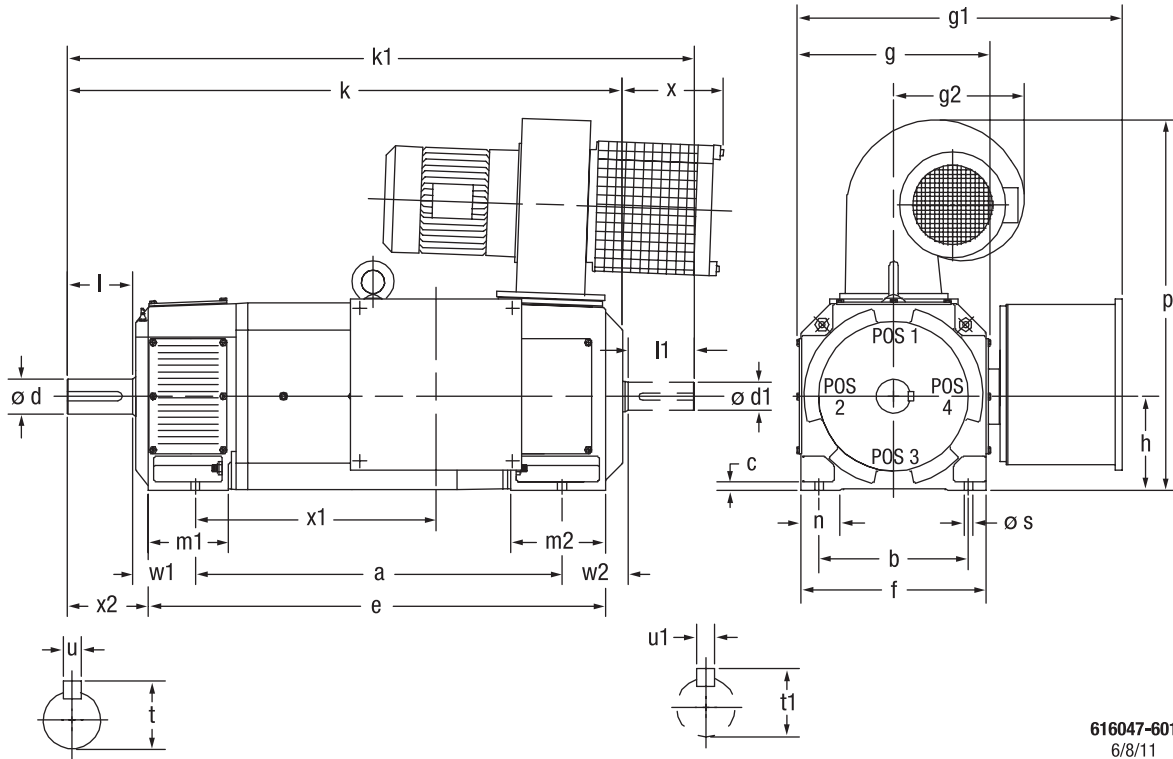

616047-601  
6/8/11

TYPE	DIN IEC	b A	c HA	f AB	g AC	g2 —	h H	n AA	p HD	s K	w1 C
GK2208-ULGK2210		356	18	446	468	315	225	85	804	19	149

TYPE	DIN IEC	a B	e BB	k L	k1 LC	m1 BA	m2 —	x —	x2 —	w2 A	DRIVE END SHAFT				OPPOSITE DRIVE END SHAFT				WT. KG.
											d D	l E	t GA	u F	d1 DA	l1 EA	t1 GC	u1 FA	
(U)GK2208		840	1060	1303	1456	184	218	208	208	101	80	170	85	22	65	140	69	18	907
(U)LGK2208		840	1104	1348	1501	184	262	208	208	145	80	170	85	22	65	140	69	18	907
(U)GK2210		960	1123	1367	1520	184	217	208	208	101	80	170	85	22	65	140	69	18	957
(U)LGK2210		960	1168	1412	1565	184	262	208	208	145	80	170	85	22	65	140	69	18	957

TYPE	DIN IEC	amps	x1 —	g1 —
(U)(L)GK2208		400	619	692
(U)(L)GK2208		800	569	742
(U)(L)GK2208		1600	543	742

TYPE	DIN IEC	amps	x1 —	g1 —
(U)(L)GK2210		400	683	692
(U)(L)GK2210		800	633	742
(U)(L)GK2210		1600	607	742

- (1) "h" Dimension Will Not Be Exceeded. Shims Up To .5 mm In Thickness Are Usually Required For Coupled Or Geared Machines.
- (2) Motor normally shipped with undrilled cable entry when over 200 amps
- (3) Shaft Extensions Are According To DIN 746. Tolerances Are Based On The ISA-Fitting System Using k6 For Diameters Up To 50 mm And m6 For Diameters Above.
- (4) The Terminal Box Size Varies With Horsepower And Voltage.
- (5) The Terminal Box Can Be Placed On The Right Or Left, Dimensions Remain The Same.
- (6) Tolerance Of Dimensions Are According To DIN.
- (7) Opposite Drive End Shaft Supplied Only When Specified.

Terminal Box Can Be Rotated For Lead Outlet At Top, Sides Or Bottom.  
Terminal Box Located On Opposite Side When F-1, W-2, W-3, W-6, W-8,  
Or C-2 Mounting Is Specified. Box Located On Top When Specified.  
Blower Assembly Can Be Located At Positions 1, 2, Or 4, Except  
Blower Assembly And Terminal Box Can Not Be Located At The Same Position.  
Motor Weight May Vary 15% For Non-Standard Ratings And/Or Accessories.  
If Mounting Clearance Details Are Required, Consult Factory.



# Industrial Direct Current Motors and Generators – RPM III

**ENCLOSURE:** Drip-Proof IP23

**COOLING:** Force Ventilated IC06, Air Filtered

**METHOD OF DRIVE:** Coupled or Belted

**MOUNTING:** Foot

## IEC TYPES GK2508 THRU UGK2510

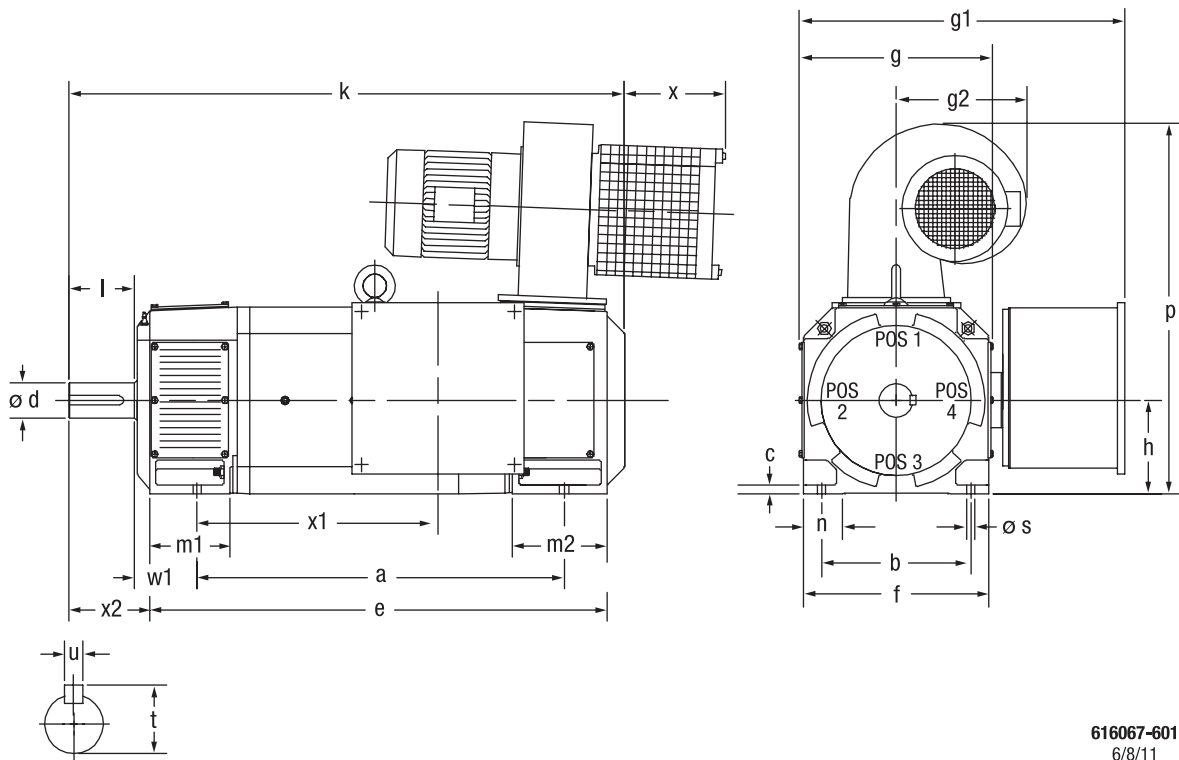

616067-601  
6/8/11

TYPE	DIN IEC	b A	c HA	f AB	g AC	h H	n AA	s K	w1 C
GK2508-ULGK2510		406	22	495	510	250	90	24	168

TYPE	DIN IEC	a B	e BB	g2	k L	m1 BA	m2	p HD	x	x2	DRIVE END SHAFT				WT. KG.
											d D	l E	t GA	u F	
(U)GK2508		900	1190	315	1433	222	310	855	124	209	90	170	95	25	1266
(U)LGK2508		1030	1335	315	1580	222	310	855	124	209	90	170	95	25	1479

TYPE	DIN IEC	amps	x1	g1
(U)GK2508		400	563	757
(U)GK2508		800	588	807
(U)GK2508		1600	639	807

TYPE	DIN IEC	amps	x1	g1
(U)GK2510		400	709	757
(U)GK2510		800	734	807
(U)GK2510		1600	758	807

- (1) "h" Dimension Will Not Be Exceeded. Shims Up To .5 mm In Thickness Are Usually Required For Coupled Or Geared Machines.
- (2) Motor normally shipped with undrilled cable entry when over 200 amps
- (3) Shaft Extensions Are According To DIN 746. Tolerances Are Based On The ISA-Fitting System Using k6 For Diameters Up To 50 mm And m6 For Diameters Above.
- (4) The Terminal Box Size Varies With Horsepower And Voltage.
- (5) The Terminal Box Can Be Placed On The Right Or Left, Dimensions Remain The Same.
- (6) Tolerance Of Dimensions Are According To DIN.

Terminal Box Can Be Rotated For Lead Outlet At Top, Sides Or Bottom.  
Terminal Box Located On Opposite Side When F-1, W-2, W-3, W-6, W-8, Or C-2 Mounting Is Specified. Box Located On Top When Specified.  
Blower Assembly Can Be Located At Positions 1, 2, Or 4, Except Blower Assembly And Terminal Box Can Not Be Located At The Same Position.  
Motor Weight May Vary 15% For Non-Standard Ratings And/Or Accessories.  
If Mounting Clearance Details Are Required, Consult Factory.

# Industrial Direct Current Motors and Generators – RPM III

**ENCLOSURE:** Drip-Proof IP23

**COOLING:** Force Ventilated IC06, Air Filtered

**METHOD OF DRIVE:** Coupled or Belted

**MOUNTING:** Foot

**ACCESSORIES:** Flange Mounted Tachometer

## IEC TYPES GK1104 THRU GK1110

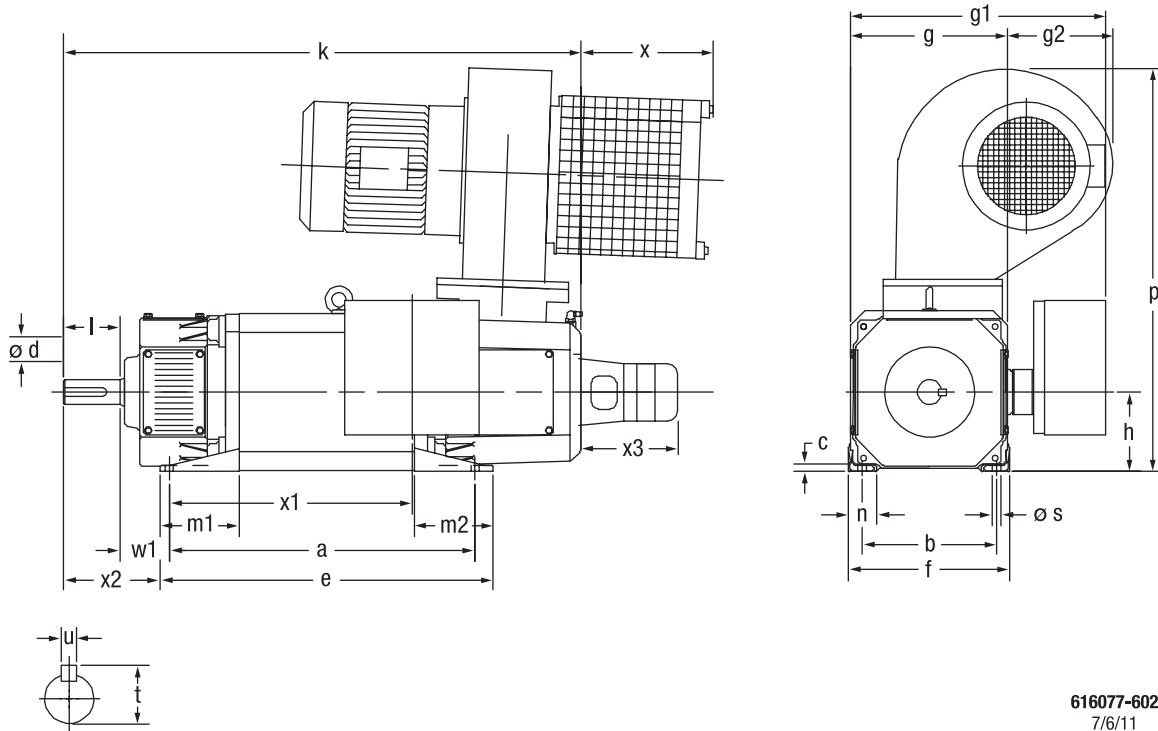

616077-602  
7/6/11

TYPE	DIN IEC	b A	c HA	f AB	g AC	g2 —	h H	n AA	p HD	s K	w1 C
GK1104-GK1110		190	6	229	222	260	112	35	578	12	70

TYPE	DIN IEC	a B	e BB	k L	m1 BA	m2 —	x —	x2 —	DRIVE END SHAFT				WT. KG.
									d D	l E	t GA	u F	
GK1104		318	356	616	111	111	205	137	38	80	41	10	84
GK1106		356	394	655	111	111	205	137	38	80	41	10	93
GK1108		406	445	705	111	111	205	137	38	80	41	10	111
GK1110		432	471	731	111	111	205	137	38	80	41	10	120

TYPE	DIN IEC	amps	x1 —	g1 —	CONDUIT SIZE
GK1104		100	228	361	Pg29, Pg16
GK1108		100	317	361	Pg29, Pg16

TYPE	DIN IEC	amps	x1 —	g1 —	CONDUIT SIZE
GK1106		100	266	361	Pg29, Pg16
GK1110		100	343	361	Pg29, Pg16

TACH MODEL	x3
REO R1B	210
TDP 0,2T-4	220
TDP 0,2T-4+FSL	220
KGP 503.30	260
DGP 506.30	310
800123-2R	105
HOHNER 3000	170
RL67	51

- (1) "h" Dimension Will Not Be Exceeded. Shims Up To .5 mm In Thickness Are Usually Required For Coupled Or Geared Machines.
- (2) Shaft Extensions Are According To DIN 746. Tolerances Are Based On The ISA-Fitting System Using k6 For Diameters Up To 50 mm And m6 For Diameters Above.
- (3) The Terminal Box Size Varies With Horsepower And Voltage.
- (4) The Terminal Box Can Be Placed On The Right Or Left, Dimensions Remain The Same.
- (5) Tolerance Of Dimensions Are According To DIN.
- (6) Opposite Drive End Shaft Supplied Only When Specified.

Terminal Box Can Be Rotated For Lead Outlet At Top, Sides Or Bottom.  
Terminal Box Located On Opposite Side When F-1, W-2, W-3, W-6, W-8,  
Or C-2 Mounting Is Specified. Box Located On Top When Specified.  
Blower Assembly Can Be Located At Positions 1, 2, Or 4, Except  
Blower Assembly And Terminal Box Can Not Be Located At The Same Position.  
Motor Weight May Vary 15% For Non-Standard Ratings And/Or Accessories.  
If Mounting Clearance Details Are Required, Consult Factory.

# Industrial Direct Current Motors and Generators – RPM III

**ENCLOSURE:** Drip-Proof IP23

**COOLING:** Force Ventilated IC06, Air Filtered

**METHOD OF DRIVE:** Coupled or Belted

**MOUNTING:** Foot

**ACCESSORIES:** Flange Mounted Tachometer

## IEC TYPES GK1303 THRU GK1311

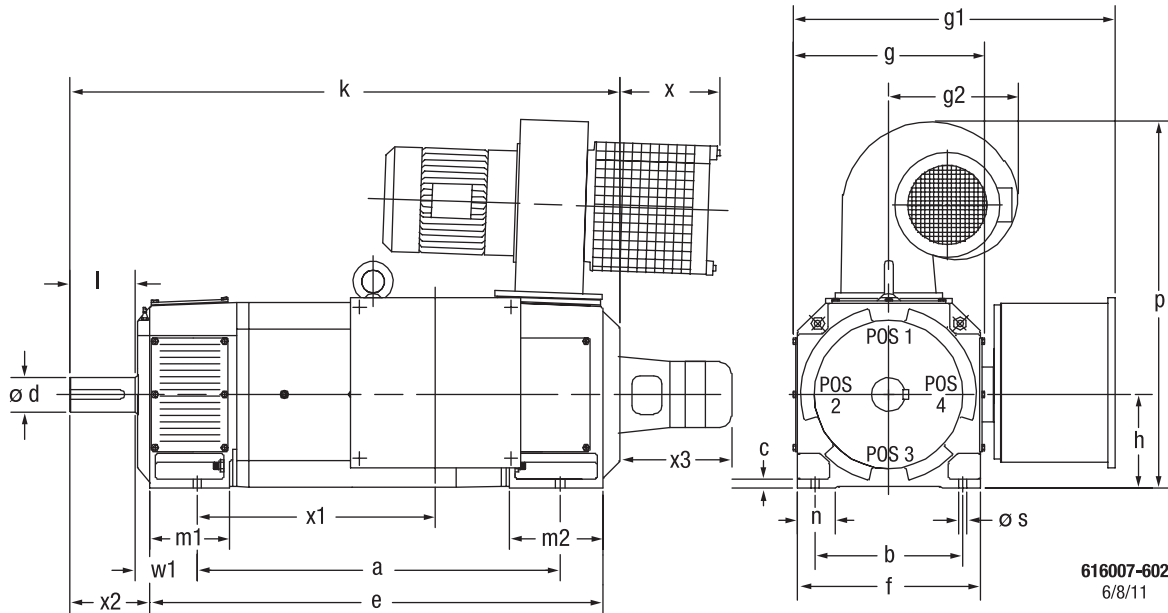

TYPE	DIN IEC	b A	c HA	f AB	g AC	h H	n AA	s K	w1 C
GK1303-UGK1311		216	11	260	275	132	48	12	89

TACH MODEL	DIN IEC	x3
REO R1B		210
TDP 0,2T-4		220
TDP 0,2T-4+FSL		220
KGP 503.30		260
KGP 506.30		310
800123-2R		105
Hohner 3000		170
HS35		51
TDP0.2LT+OG9		230
RL67		51
H20		103

TYPE	DIN IEC	a B	e BB	g2	k L	m1 BA	m2	p HD	x	x2	DRIVE END SHAFT				WT. KG.
											d D	l E	t GA	u F	
(U)GK1303		440	572	254	736	132	173	578	197	139	48	110	51,5	14	154
(U)GK1305		490	603	254	767	132	173	578	197	139	48	110	51,5	14	166
(U)GK1307		490	645	254	809	132	173	578	197	139	48	110	51,5	14	179
(U)GK1309		540	676	254	840	132	173	578	197	139	48	110	51,5	14	191
(U)GK1311		610	746	254	910	132	173	578	197	139	48	110	51,5	14	215

TYPE	DIN IEC	amps	x1	g1	CONDUIT SIZE
(U)GK1303		100	238	409	Pg29, Pg16
(U)GK1303		200	225	423	Pg36, Pg16

TYPE	DIN IEC	amps	x1	g1	CONDUIT SIZE
(U)GK1305		100	270	409	Pg29, Pg16
(U)GK1305		200	257	423	Pg36, Pg16

TYPE	DIN IEC	amps	x1	g1	CONDUIT SIZE
(U)GK1307		100	311	409	Pg29, Pg16
(U)GK1307		200	298	423	Pg36, Pg16

TYPE	DIN IEC	amps	x1	g1	CONDUIT size
(U)GK1309		100	343	409	Pg29, Pg16
(U)GK1309		200	330	423	Pg36, Pg16

TYPE	DIN IEC	amps	x1	g1	CONDUIT size
(U)GK1311		100	412	409	Pg29, Pg16
(U)GK1311		200	400	423	Pg36, Pg16

- "h" Dimension Will Not Be Exceeded. Shims Up To .5 Mm In Thickness Are Usually Required For Coupled Or Geared Machines.
- Shaft Extensions Are According To DIN 746. Tolerances Are Based On The Iso-Fitting System Using k6 For Diameters Up To 50 mm And m6 For Diameters Above.
- The Terminal Box Size Varies With Horsepower And Voltage.
- The Terminal Box Can Be Placed On The Right Or Left, Dimensions Remain The Same.
- Tolerance Of Dimensions Are According To DIN.

Terminal Box Can Be Rotated For Lead Outlet At Top, Sides Or Bottom.  
Terminal Box Located On Opposite Side When F-1, W-2, W-3, W-6, W-8, Or C-2 Mounting Is Specified. Box Located On Top When Specified.  
Blower Assembly Can Be Located At Positions 1, 2, Or 4, Except Blower Assembly And Terminal Box Can Not Be Located At The Same Position.  
Motor Weight May Vary 15% For Non-Standard Ratings And/Or Accessories.  
If Mounting Clearance Details Are Required, Consult Factory.

# Industrial Direct Current Motors and Generators – RPM III

**ENCLOSURE:** Drip-Proof IP23

**COOLING:** Force Ventilated IC06, Air Filtered

**METHOD OF DRIVE:** Coupled or Belted

**MOUNTING:** Foot

**ACCESSORIES:** Flange Mounted Tachometer

## IEC TYPES GK1606 THRU GK1610

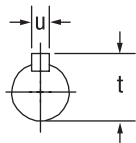
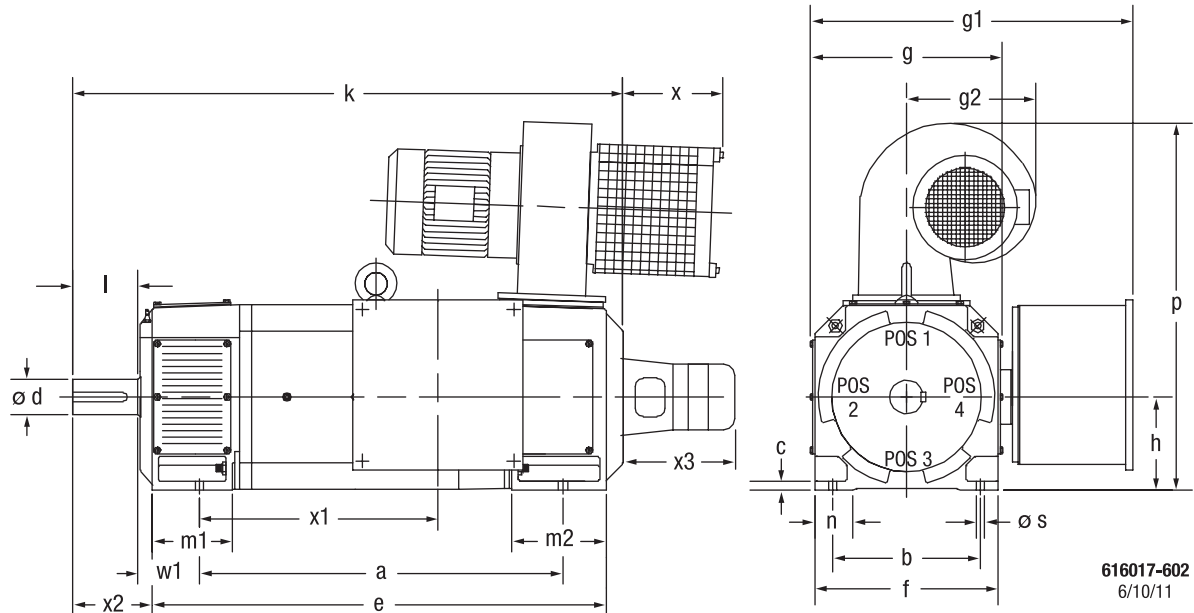

TYPE	DIN IEC	b A	c HA	f AB	g AC	h H	n AA	s K	w1 C
GK1606-GK1610		254	12	314	332	160	55	15	108

TACH MODEL	x3
REO R1B	210
TDP 0,2T-4	220
TDP 0,2T-R+FSL	220
DGP 503.30	260
DGP 506.30	310
800123-2R	105
HOHNER 3000	170
TS2014	143
HS35	51

TYPE	DIN IEC	a B	e BB	g2	k L	m1 BA	m2	p HD	x	x2	DRIVE END SHAFT				WT. KG.
											d D	l E	t GA	u F	
GK1606		550	713	242	908	154	203	629	185	172	55	110	59	16	274
GK1608		630	795	242	996	154	203	629	185	172	55	110	59	16	313
GK1610		720	897	242	1098	154	203	629	185	172	55	110	59	16	363

TYPE	DIN IEC	amps	x1	g1	CONDUIT SIZE
GK1606		100	334	453	Pg29, Pg16
GK1606		200	322	467	Pg36, Pg16
GK1606		400	339	560	(2)
GK1606		800	288	610	(2)

TYPE	DIN IEC	amps	x1	g1	CONDUIT SIZE
GK1608		100	416	453	Pg29, Pg16
GK1608		200	404	467	Pg36, Pg16
GK1608		400	421	560	(2)
GK1608		800	370	610	(2)

TYPE	DIN IEC	amps	—	g1	CONDUIT SIZE
GK1610		100	518	453	Pg29, Pg16
GK1610		200	506	467	Pg36 Pg16
GK1610		400	523	560	(2)
GK1610		800	472	610	(2)

- "h" Dimension Will Not Be Exceeded. Shims Up To .5 mm In Thickness Are Usually Required For Coupled Or Geared Machines.
- Motor normally shipped with undrilled cable entry when over 200 amps
- Shaft Extensions Are According To DIN 746. Tolerances Are Based On The ISA-Fitting System Using k6 For Diameters Up To 50 mm And m6 For Diameters Above.
- The Terminal Box Size Varies With Horsepower And Voltage.
- The Terminal Box Can Be Placed On The Right Or Left, Dimensions Remain The Same.
- Tolerance Of Dimensions Are According To DIN.

Terminal Box Can Be Rotated For Lead Outlet At Top, Sides Or Bottom.  
Terminal Box Located On Opposite Side When F-1, W-2, W-3, W-6, W-8,  
Or C-2 Mounting Is Specified. Box Located On Top When Specified.  
Blower Assembly Can Be Located At Positions 1, 2, Or 4, Except  
Blower Assembly And Terminal Box Can Not Be Located At The Same Position.  
Motor Weight May Vary 15% For Non-Standard Ratings And/Or Accessories.  
If Mounting Clearance Details Are Required, Consult Factory.

# Industrial Direct Current Motors and Generators – RPM III

**ENCLOSURE:** Drip-Proof IP23

**COOLING:** Force Ventilated IC06, Air Filtered

**METHOD OF DRIVE:** Coupled or Belted

**MOUNTING:** Foot

**ACCESSORIES:** Flange Mounted Tachometer

## IEC TYPES GK1808 THRU UGK1810

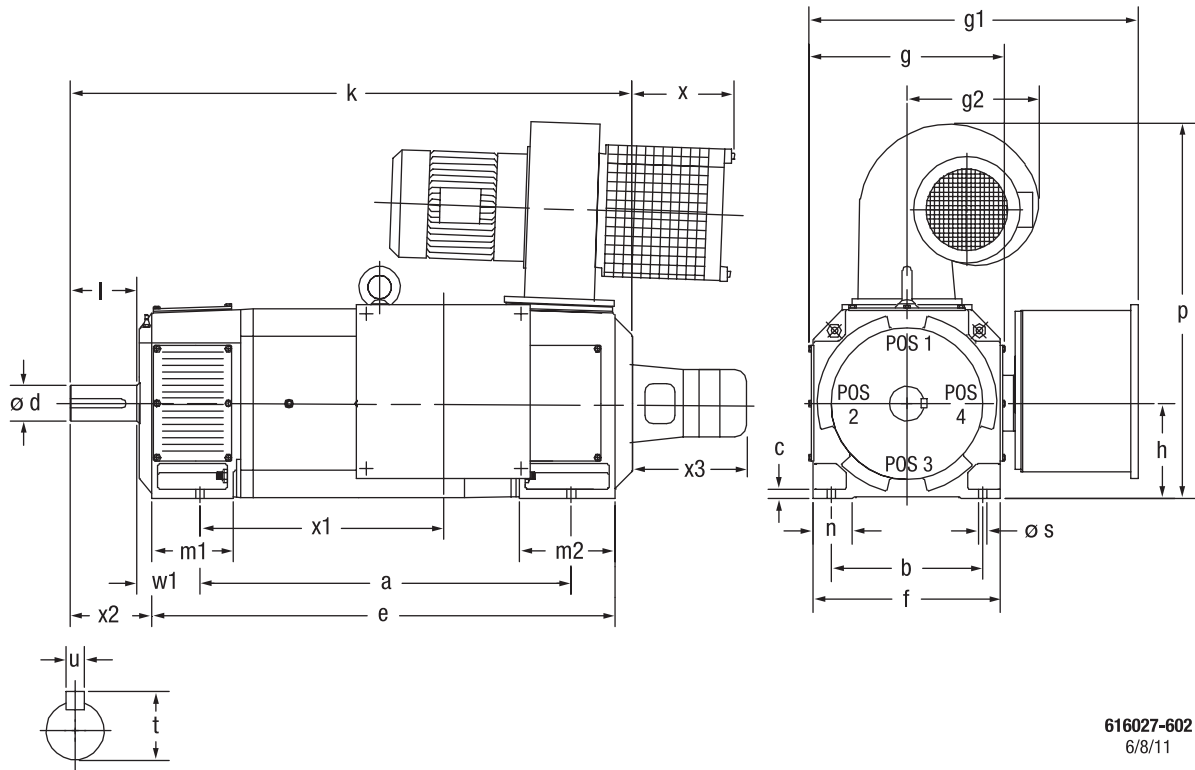

616027-602  
6/8/11

TYPE	DIN IEC	b	c	f	g	g2	h	n	p	s	w1
		A	HA	AB	AC	—	H	AA	HD	K	C
GK1808-UGK1810		279	17	358	364	235	180	75	667	15	121

TACH MODEL	x3
REO R1B	210
TDP 0,2T-4	220
TDP 0,2T-4+FSL	220
KGP 503.30	260
KGP 506.30	310
800123-2	105
HOHNER 3000	170
845H	160
HOHNER 30	190

DIN TYPE	IEC	a	e	k	m1	m2	x	x2	w2	DRIVE END SHAFT				WT. KG.
										d	l	t	u	
B	BB	L	BA	—	—	—	CA	D	E	GA	F			
(U)GK1808		710	860	1068	172	234	162	170	109	70	140	74,5	20	424
(U)GK1810		790	999	1207	172	234	162	170	168	70	140	74,5	20	508

DIN TYPE	IEC	amps	x1	g1	CONDUIT SIZE
			—	—	
(U)GK1808		200	406	502	Pg36, Pg16
(U)GK1808		400	428	596	(2)
(U)GK1808		800	377	646	(2)
(U)GK1808		1600	352	646	(2)

DIN TYPE	IEC	amps	x1	g1	CONDUIT SIZE
			—	—	
(U)GK1808		200	546	502	Pg36, Pg16
(U)GK1808		400	568	596	(2)
(U)GK1808		800	517	646	(2)
(U)GK1808		1600	492	646	(2)

- (1) "h" Dimension Will Not Be Exceeded. Shims Up To .5 mm In Thickness Are Usually Required For Coupled Or Geared Machines.
- (2) Motor normally shipped with undrilled cable entry when over 200 amps
- (3) Shaft Extensions Are According To DIN 746. Tolerances Are Based On The ISA-Fitting System Using k6 For Diameters Up To 50 mm And m6 For Diameters Above.
- (4) The Terminal Box Size Varies With Horsepower And Voltage.
- (5) The Terminal Box Can Be Placed On The Right Or Left, Dimensions Remain The Same.
- (6) Tolerance Of Dimensions Are According To DIN.

Terminal Box Can Be Rotated For Lead Outlet At Top, Sides Or Bottom.  
Terminal Box Located On Opposite Side When F-1, W-2, W-3, W-6, W-8,  
Or C-2 Mounting Is Specified. Box Located On Top When Specified.  
Blower Assembly Can Be Located At Positions 1, 2, Or 4, Except  
Blower Assembly And Terminal Box Can Not Be Located At The Same Position.  
Motor Weight May Vary 15% For Non-Standard Ratings And/Or Accessories.  
If Mounting Clearance Details Are Required, Consult Factory.

# Industrial Direct Current Motors and Generators – RPM III

**ENCLOSURE:** Drip-Proof IP23

**COOLING:** Force Ventilated IC06, Air Filtered

**METHOD OF DRIVE:** Coupled or Belted

**MOUNTING:** Foot

**ACCESSORIES:** Flange Mounted Tachometer

## IEC TYPES GK2008 THRU ULGK2010

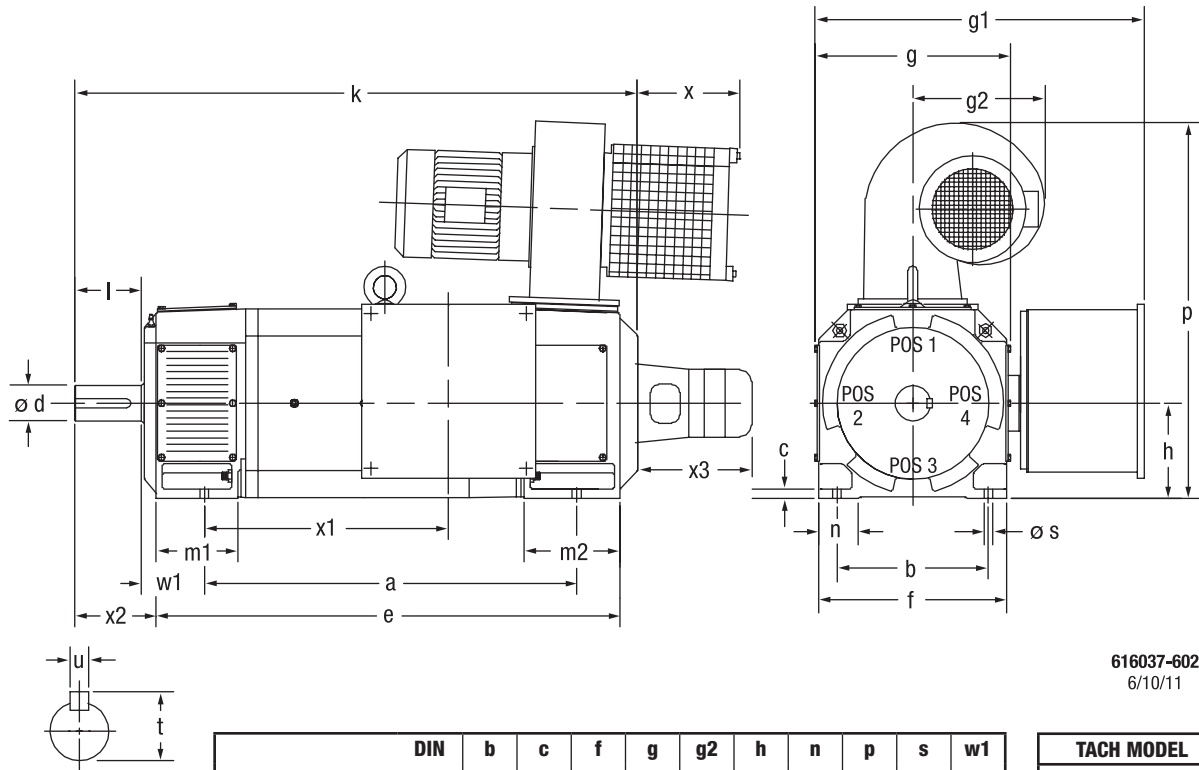

616037-602  
6/10/11

TYPE	DIN IEC	b A	c HA	f AB	g AC	g2 —	h H	n AA	p HD	s K	w1 C
GK2008-ULGK2010		318	18	396	418	216	200	80	711	19	133

TACH MODEL	x3
REO R1B	210
TDP 0,2T-4	220
TDP 0,2T-4+FSL	220
KGP 503.30	260
KGP 506.30	310
800123-2R	105
HOHNER 3000	170
HS35	51
INLAND TGF2100	45
HSD35	84

TYPE	DIN IEC	a B	e BB	k L	m1 BA	m2 —	x —	x2 —	DRIVE END SHAFT				WT. KG.
									d D	l E	t GA	u F	
(U)GK2008		780	974	1182	172	202	172	172	75	140	79,5	20	665
(U)LGK2008		780	1038	1245	172	265	172	172	75	140	79,5	20	665
(U)GK2010		900	1050	1258	172	202	172	172	75	140	79,5	20	717
(U)LGK2010		900	1114	1321	172	265	172	172	75	140	79,5	20	717

TYPE	DIN IEC	amps	x1 —	g1 —
(U)(L)GK2008		400	563	642
(U)(L)GK2008		800	512	692
(U)(L)GK2008		1600	487	692

TYPE	DIN IEC	amps	x1 —	g1 —
(U)(L)GK2010		400	639	642
(U)(L)GK2010		800	588	692
(U)(L)GK2010		1600	563	692

- (1) "h" Dimension Will Not Be Exceeded. Shims Up To .5 mm In Thickness Are Usually Required For Coupled Or Geared Machines.
- (2) Motor normally shipped with undrilled cable entry when over 200 amps
- (3) Shaft Extensions Are According To DIN 746. Tolerances Are Based On The ISA-Fitting System Using k6 For Diameters Up To 50 mm And m6 For Diameters Above.
- (4) The Terminal Box Size Varies With Horsepower And Voltage.
- (5) The Terminal Box Can Be Placed On The Right Or Left, Dimensions Remain The Same.
- (6) Tolerance Of Dimensions Are According To DIN.

Terminal Box Can Be Rotated For Lead Outlet At Top, Sides Or Bottom.  
Terminal Box Located On Opposite Side When F-1, W-2, W-3, W-6, W-8, Or C-2 Mounting Is Specified. Box Located On Top When Specified.  
Blower Assembly Can Be Located At Positions 1, 2, Or 4, Except Blower Assembly And Terminal Box Can Not Be Located At The Same Position.  
Motor Weight May Vary 15% For Non-Standard Ratings And/Or Accessories.  
If Mounting Clearance Details Are Required, Consult Factory.

**Industrial Direct Current Motors and Generators – RPM III**

**ENCLOSURE:** Drip-Proof IP23

**COOLING:** Force Ventilated IC06, Air Filtered

**METHOD OF DRIVE:** Coupled or Belted

**MOUNTING:** Foot

**ACCESSORIES:** Flange Mounted Tachometer

**IEC TYPES GK2208 THRU ULGK2210**

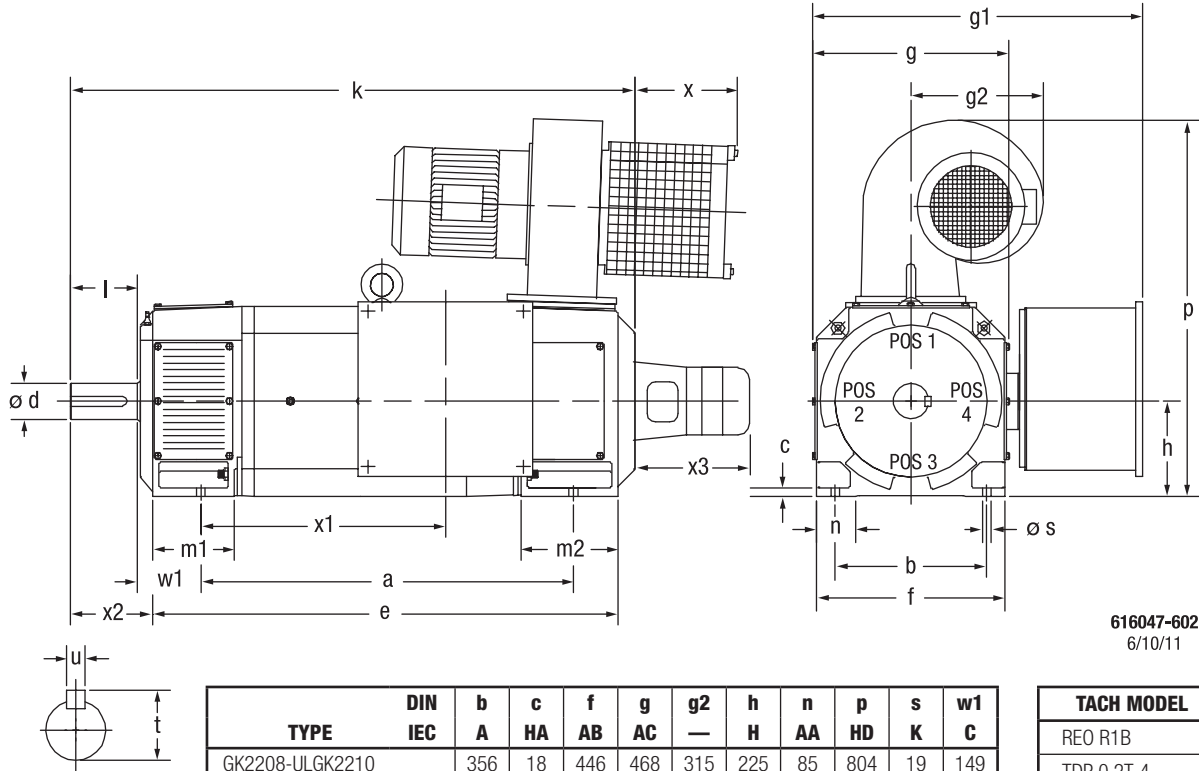

616047-602  
6/10/11

TYPE	DIN IEC	b A	c HA	f AB	g AC	g2 —	h H	n AA	p HD	s K	w1 C
GK2208-ULGK2210		356	18	446	468	315	225	85	804	19	149

TACH MODEL	x3
REO R1B	210
TDP 0,2T-4	220
TDP 0,2T-4+FSL	220
KGP 503.30	260
KGP 506.30	310
800123-2R	105
RL67	51
HS35	51

TYPE	DIN IEC	a B	e BB	k L	m1 BA	m2 —	x —	x2 —	DRIVE END SHAFT				WT. KG.
									d D	l E	t GA	u F	
(U)GK2208		840	1060	1303	184	217	208	208	80	170	85	22	907
(U)LGK2208		840	1104	1348	184	262	208	208	80	170	85	22	907
(U)GK2210		960	1123	1367	184	217	208	208	80	170	85	22	957
(U)LGK2210		960	1168	1412	184	262	208	208	80	170	85	22	957

TYPE	DIN IEC	amps	x1	g1
(U)(L)GK2208		400	619	692
(U)(L)GK2208		800	569	742
(U)(L)GK2208		1600	543	742

TYPE	DIN IEC	amps	x1	g1
(U)(L)GK2210		400	683	692
(U)(L)GK2210		800	633	742
(U)(L)GK2210		1600	607	742

- (1) "h" Dimension Will Not Be Exceeded. Shims Up To .5 mm In Thickness Are Usually Required For Coupled Or Geared Machines.
- (2) Motor normally shipped with undrilled cable entry when over 200 amps
- (3) Shaft Extensions Are According To DIN 746. Tolerances Are Based On The ISA-Fitting System Using k6 For Diameters Up To 50 mm And m6 For Diameters Above.
- (4) The Terminal Box Size Varies With Horsepower And Voltage.
- (5) The Terminal Box Can Be Placed On The Right Or Left, Dimensions Remain The Same.
- (6) Tolerance Of Dimensions Are According To DIN.

Terminal Box Can Be Rotated For Lead Outlet At Top, Sides Or Bottom.  
Terminal Box Located On Opposite Side When F-1, W-2, W-3, W-6, W-8,  
Or C-2 Mounting Is Specified. Box Located On Top When Specified.  
Blower Assembly Can Be Located At Positions 1, 2, Or 4, Except  
Blower Assembly And Terminal Box Can Not Be Located At The Same Position.  
Motor Weight May Vary 15% For Non-Standard Ratings And/Or Accessories.  
If Mounting Clearance Details Are Required, Consult Factory.

# Industrial Direct Current Motors and Generators – RPM III

**ENCLOSURE:** Drip-Proof IP23

**COOLING:** Force Ventilated IC06, Air Filtered

**METHOD OF DRIVE:** Coupled or Belted

**MOUNTING:** Foot

**ACCESSORIES:** Flange Mounted Tachometer

## IEC TYPES GK2508 THRU UGK2510

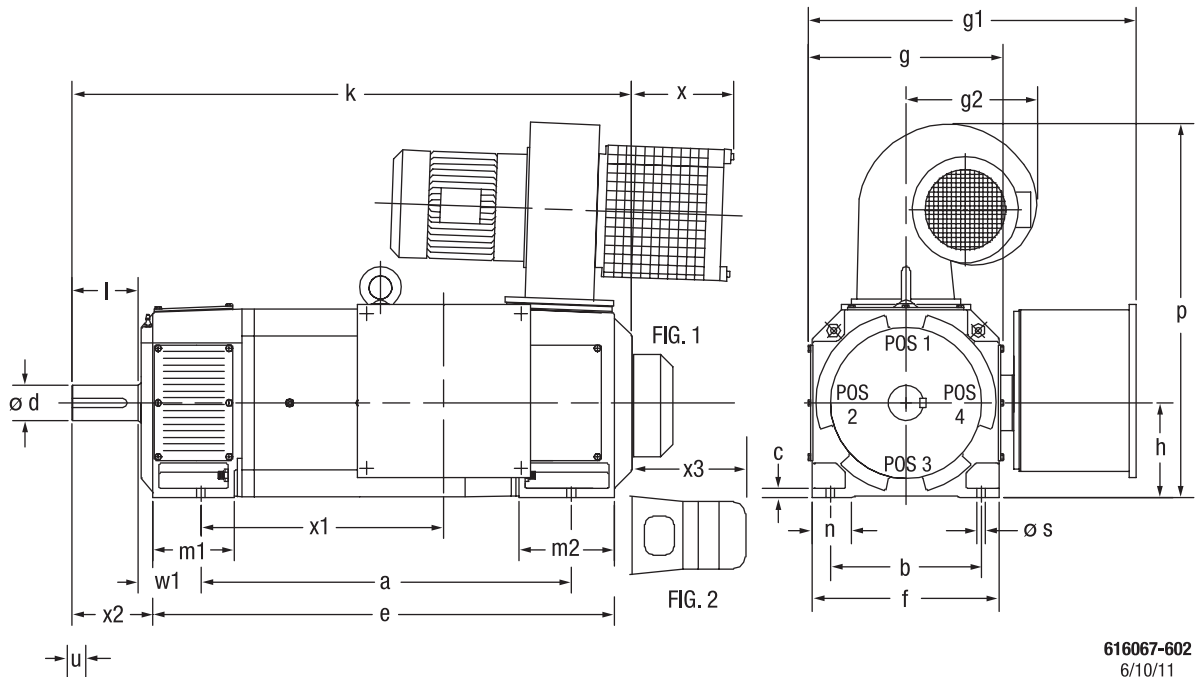

616067-602  
6/10/11

TYPE	DIN IEC	b A	c HA	f AB	g AC	h H	n AA	s K	w1 C
GK2508-UGK2510		406	22	495	510	250	90	24	168

TACH MODEL	x3	WT LBS.	FIG.
REO R1B	210	15	2
TDP 0,2T-4	220	--	2
TDP 0,2T-4+FSL	220	--	2
KGP 503.30	260	--	2
KGP 506.30	310	--	2
800123-2R	105	15	2
HÖHNER 3000	170	--	2
M785 (AVTRON)	262	20	2
LITTON G71	225	--	2
RD-120	43	5	1

DIN TYPE	IEC	a B	e BB	g2	k L	m1 BA	m2	p HD	x	x2	DRIVE END SHAFT				WT. KG.
											d D	l E	t GA	u F	
(U)GK2508		900	1190	315	1433	222	310	855	124	209	90	170	95	25	1266
(U)LGK2508		1030	1335	315	1580	222	310	855	124	209	90	170	95	25	1479

TYPE	DIN IEC	amps	x1	g1
(U)GK2508		400	563	757
(U)GK2508		800	588	807
(U)GK2508		1600	639	807

TYPE	DIN IEC	amps	x1	g1
(U)GK2510		400	709	757
(U)GK2510		800	734	807
(U)GK2510		1600	758	807

- "h" Dimension Will Not Be Exceeded. Shims Up To .5 mm In Thickness Are Usually Required For Coupled Or Geared Machines.
- Motor normally shipped with undrilled cable entry when over 200 amps
- Shaft Extensions Are According To DIN 746. Tolerances Are Based On The ISA-Fitting System Using k6 For Diameters Up To 50 mm And m6 For Diameters Above.
- The Terminal Box Size Varies With Horsepower And Voltage.
- The Terminal Box Can Be Placed On The Right Or Left, Dimensions Remain The Same.
- Tolerance Of Dimensions Are According To DIN.

Terminal Box Can Be Rotated For Lead Outlet At Top, Sides Or Bottom.  
Terminal Box Located On Opposite Side When F-1, W-2, W-3, W-6, W-8,  
Or C-2 Mounting Is Specified. Box Located On Top When Specified.  
Blower Assembly Can Be Located At Positions 1, 2, Or 4, Except  
Blower Assembly And Terminal Box Can Not Be Located At The Same Position.  
Motor Weight May Vary 15% For Non-Standard Ratings And/Or Accessories.  
If Mounting Clearance Details Are Required, Consult Factory.



**Industrial Direct Current Motors and Generators – RPM III**

**ENCLOSURE:** Drip-Proof IP23  
**MOUNTING:** Foot

**COOLING:** Force Ventilated IC06,  
Integral Blower and Motor

**IEC FRAME GK2806 THRU GK2810**

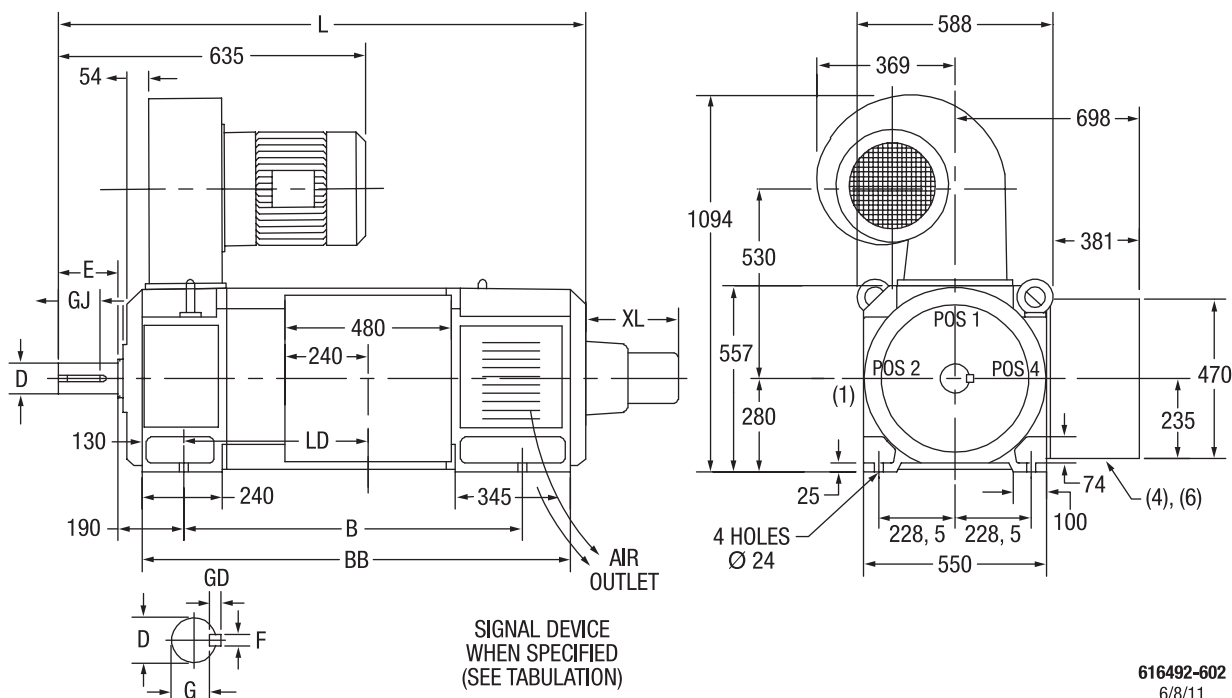

SIGNAL	XL	WT. (KG.)
5PY	276	3,2
BC-42	340	11,4
BC-46	398	15,9
M627A	267	6,4
M628A	267	6,4
M-727A	267	6,4
M-737A	267	6,4
RD-11	254	7,7
RD-51	424	17,2
RD-61	254	7,7
H56	254	7,7
RE-045	65	2,3
RE-210	389	13,6
TG2168A	65	2,3
TS2014N	165	2,3
TS2087N	279	6,4
REOR1	266	3,2
HS35	60	1,0
SL85	60	1,0

FRAME	DIMENSIONS ARE IN MILLIMETERS										WT. (KG.)
	L	LD	BB	B	DRIVE END SHAFT AND KEY						
					D <sup>(2)</sup>	E	F	G <sup>(3)</sup>	GD	GJ	
GK2806	1507	503	1184	900	100	210	28	90	16	165	1485
UGK2806	1507	503	1184	900	110	210	28	90	16	165	1485
GK2808	1607	603	1284	1000	100	210	28	90	16	165	1674
UGK2808	1607	603	1284	1000	110	210	28	90	16	165	1674
GK2810	1767	763	1444	1160	100	210	28	90	16	165	1955
UGK2810	1767	763	1444	1160	110	210	28	90	16	165	1955

- (1) This Dimension Will Not Be Exceeded. Shims Up To 1,5 mm In Thickness Are Usually Required For Coupled Or Geared Machines
- (2) "D" and "DA" Vary -0,025.
- (3) "G" and "GB" Vary -0,38.
- (4) Removable Cover Plate For Customer Drilling.  
Terminal Box Can Be Positioned For Either Top Or Bottom Conduit Entry.
- (5) Opposite Drive End Shaft Supplied Only When Specified.
- (6) Terminal Box Located On Opposite Side When Specified.
- (7) Air Filter Supplied Only When Specified.  
Blower Assembly Can Be Located At Positions 1, 2, Or 4 Except Blower Assembly And Terminal Can Not Be Located At The Same Position.

# Industrial Direct Current Motors and Generators – RPM III

**ENCLOSURE:** Drip-Proof IP23  
**METHOD OF DRIVE:** Coupled or Belted

**COOLING:** Force Ventilated IC06, Air Filtered  
**MOUNTING:** Flange Mounted

## IEC TYPES GK1303Y THRU GK1311Y

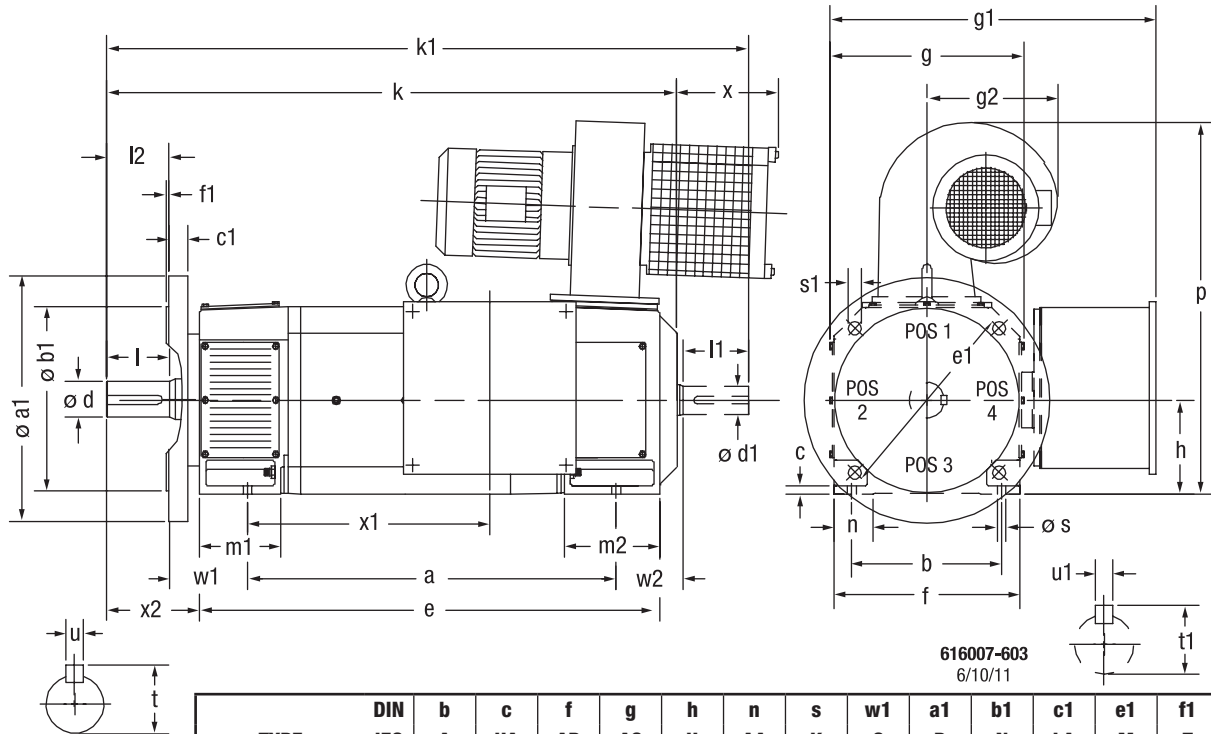

TYPE	DIN IEC	b A	c HA	f AB	g AC	h H	n AA	s K	w1 C	a1 P	b1 N	c1 LA	e1 M	f1 T	s1 S
GK1303Y-GK1311Y		216	11	260	275	132	48	12	146	350	250	16	300	4	19

TYPE	DIN IEC	a B	e BB	g2	k L	k1 LC	m1 BA	m2	p HD	x	x2	w2 CA	DRIVE END SHAFT				OPPOSITE DRIVE END SHAFT				WT. KG.	
													d D	l E	l2	t GA	u F	d1 DA	l1 EA	t1 GC		u1 FA
GK1303Y		440	572	254	795	917	132	173	578	197	197	109	48	110	110	51,5	14	42	110	45	12	159
GK1305Y		490	603	254	826	949	132	173	578	197	197	91	48	110	110	51,5	14	42	110	45	12	171
GK1307Y		490	645	254	868	990	132	173	578	197	197	132	48	110	110	51,5	14	42	110	45	12	184
GK1309Y		540	676	254	899	1022	132	173	578	197	197	114	48	110	110	51,5	14	42	110	45	12	196
GK1311Y		610	746	254	969	1092	132	173	578	197	197	114	48	110	110	51,5	14	42	110	45	12	221

TYPE	DIN IEC	amps	x1	g1	CONDUIT SIZE
GK1303Y		63	254	391	Pg21, Pg16
GK1303Y		100	238	409	Pg29, Pg16
GK1303Y		200	225	423	Pg36, Pg16

TYPE	DIN IEC	amps	x1	g1	CONDUIT SIZE
GK1305Y		63	285	391	Pg21, Pg16
GK1305Y		100	270	409	Pg29, Pg16
GK1305Y		200	257	423	Pg36, Pg16

TYPE	DIN IEC	amps	x1	g1	CONDUIT SIZE
GK1307Y		63	327	391	Pg21, Pg16
GK1307Y		100	311	409	Pg29, Pg16
GK1307Y		200	298	423	Pg36, Pg16

TYPE	DIN IEC	amps	x1	g1	CONDUIT SIZE
GK1309Y		63	358	391	Pg21, Pg16
GK1309Y		100	343	409	Pg29, Pg16
GK1309Y		200	330	423	Pg36, Pg16

TYPE	DIN IEC	amps	x1	g1	CONDUIT SIZE
GK1311Y		63	428	391	Pg21, Pg16
GK1311Y		100	412	409	Pg29, Pg16
GK1311Y		200	400	423	Pg36, Pg16

- "h" Dimension Will Not Be Exceeded. Shims Up To .5 mm In Thickness Are Usually Required For Coupled Or Geared Machines.
- Shaft Extensions Are According To DIN 746. Tolerances Are Based On The ISA-Fitting System Using k6 For Diameters Up To 50 mm and m6 For Diameters Above.
- The Terminal Box Size Varies With Horsepower And Voltage.
- The Terminal Box Can Be Placed On The Right Or Left, Dimensions Remain The Same.
- Tolerance Of Dimensions Are According To DIN.
- Opposite Drive End Shaft Supplied Only When Specified.
- Tolerance For Flanges According To DIN 42948.

Terminal Box Can Be Rotated For Lead Outlet At Top, Sides Or Bottom. Terminal Box Located On Opposite Side When F-1, W-2, W-3, W-6, W-8, Or C-2 Mounting Is Specified. Box Located On Top When Specified. Blower Assembly Can Be Located At Positions 1, 2, Or 4, Except Blower Assembly And Terminal Box Can Not Be Located At The Same Position. Motor Weight May Vary 15% For Non-Standard Ratings And/Or Accessories. If Mounting Clearance Details Are Required, Consult Factory.

**Industrial Direct Current Motors and Generators – RPM III**

**ENCLOSURE:** Drip-Proof IP23  
**METHOD OF DRIVE:** Coupled or Belted

**COOLING:** Force Ventilated IC06, Air Filtered  
**MOUNTING:** Flange Mounted

**IEC TYPES GK1606Y THRU GK1610Y**

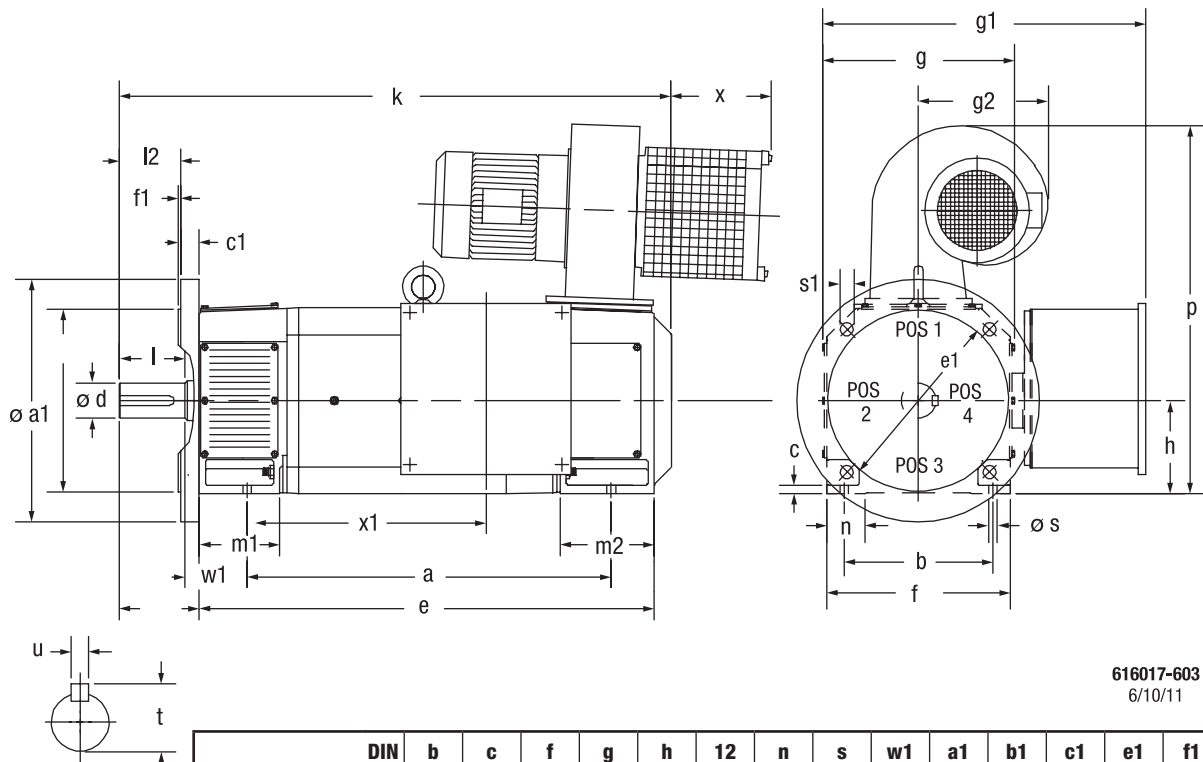

616017-603  
6/10/11

TYPE	DIN IEC	b A	c HA	f AB	g AC	h H	12 —	n AA	s K	w1 C	a1 P	b1 N	c1 LA	e1 M	f1 T	s1 S
GK1606Y-GK1610Y		254	12	314	332	160	140	55	15	138	400	300	15	350	5	19

TYPE	DIN IEC	a B	e BB	g2 —	k L	m1 BA	m2 —	p HD	x —	x2 —	DRIVE END SHAFT				WT. KG.
											d D	l E	t GA	u F	
GK1606Y		550	713	242	943	154	203	629	185	202	60	140	64	18	285
GK1608Y		630	795	242	1026	154	203	629	185	202	60	140	64	18	324
GK1610Y		720	897	242	1128	154	203	629	185	202	60	140	64	18	374

TYPE	DIN IEC	amps	x1 —	g1 —	CONDUIT SIZE
GK1606Y		63	350	435	Pg21, Pg16
GK1606Y		100	334	453	Pg29, Pg16
GK1606Y		200	322	467	Pg36, Pg16
GK1606Y		400	339	560	(2)
GK1606Y		800	288	610	(2)

TYPE	DIN IEC	amps	x1 —	g1 —	CONDUIT SIZE
GK1608Y		63	432	435	Pg21, Pg16
GK1608Y		100	416	453	Pg29, Pg16
GK1608Y		200	404	467	Pg36, Pg16
GK1608Y		400	421	560	(2)
GK1608Y		800	370	610	(2)

TYPE	DIN IEC	amps	x1 —	g1 —	CONDUIT SIZE
GK1610Y		63	534	435	Pg21, Pg16
GK1610Y		100	518	453	Pg29, Pg16
GK1610Y		200	506	467	Pg36 Pg16
GK1610Y		400	523	560	(2)
GK1610Y		800	472	610	(2)

- (1) "h" Dimension Will Not Be Exceeded. Shims Up To .5 mm In Thickness Are Usually Required For Coupled Or Geared Machines.
- (2) Motor normally shipped with undrilled cable entry when over 200 amps
- (3) Shaft Extensions Are According To DIN 746. Tolerances Are Based On The ISA-Fitting System Using k6 For Diameters Up To 50 mm And m6 For Diameters Above.
- (4) The Terminal Box Size Varies With Horsepower And Voltage.
- (5) The Terminal Box Can Be Placed On The Right Or Left, Dimensions Remain The Same.
- (6) Tolerance Of Dimensions Are According To DIN.
- (7) Tolerance for Flanges according to DIN 42948

Terminal Box Can Be Rotated For Lead Outlet At Top, Sides Or Bottom.  
Terminal Box Located On Opposite Side When F-1, W-2, W-3, W-6, W-8,  
Or C-2 Mounting Is Specified. Box Located On Top When Specified.  
Blower Assembly Can Be Located At Positions 1, 2, Or 4, Except  
Blower Assembly And Terminal Box Can Not Be Located At The Same Position.  
Motor Weight May Vary 15% For Non-Standard Ratings And/Or Accessories.  
If Mounting Clearance Details Are Required, Consult Factory.

# Industrial Direct Current Motors and Generators – RPM III

**ENCLOSURE:** Drip-Proof IP23

**COOLING:** Force Ventilated IC06, Air Filtered

**METHOD OF DRIVE:** Coupled or Belted

**MOUNTING:** Flange Mounted

**ACCESSORIES:** Flange Mounted Tachometer

## IEC TYPES GK1606Y THRU GK1610Y

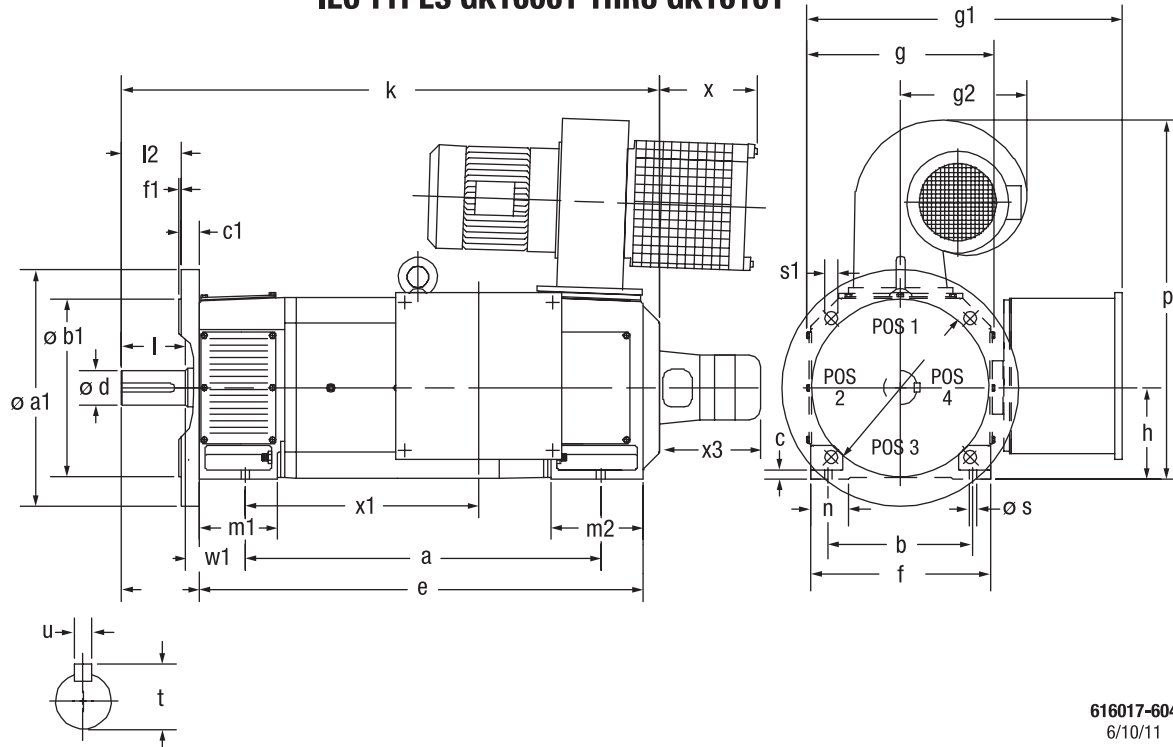

616017-604  
6/10/11

TYPE	DIN IEC	b A	c HA	f AB	g AC	h H	12 —	n AA	s K	w1 C	a1 P	b1 N	c1 LA	e1 M	f1 T	s1 S
GK1606Y-GK1610Y		254	12	314	332	160	140	55	15	138	400	300	15	350	5	19

TACH MODEL	x3
REO R1B	210
TDP 0,2T-4	220
TDP 0,2T-4+FSL	220
KGP 503.30	260
KGP 506.30	310
800123-2R	105
HÖHNER 3000	170
845H	160
TS2014	143

TYPE	DIN IEC	a B	e BB	g2 —	k L	m1 BA	m2 —	p HD	x —	x2 —	DRIVE END SHAFT				WT. KG.
											d D	l E	t GA	u F	
GK1606Y		550	713	242	943	154	203	629	185	202	60	140	64	18	285
GK1608Y		630	795	242	1026	154	203	629	185	202	60	140	64	18	324
GK1610Y		720	897	242	1128	154	203	629	185	202	60	140	64	18	374

TYPE	DIN IEC	amps	x1 —	g1 —	CONDUIT SIZE
GK1606Y		100	334	453	Pg29, Pg16
GK1606Y		200	322	467	Pg36, Pg16
GK1606Y		400	339	560	(2)
GK1606Y		800	288	610	(2)

TYPE	DIN IEC	amps	x1 —	g1 —	CONDUIT SIZE
GK1608Y		100	416	453	Pg29, Pg16
GK1608Y		200	404	467	Pg36, Pg16
GK1608Y		400	421	560	(2)
GK1608Y		800	370	610	(2)

TYPE	DIN IEC	amps	x1 —	g1 —	CONDUIT SIZE
GK1610Y		100	518	453	Pg29, Pg16
GK1610Y		200	506	467	Pg36 Pg16
GK1610Y		400	523	560	(2)
GK1610Y		800	472	610	(2)

- (1) "h" Dimension Will Not Be Exceeded. Shims Up To .5 mm In Thickness Are Usually Required For Coupled Or Geared Machines.
- (2) Motor normally shipped with undrilled cable entry when over 200 amps
- (3) Shaft Extensions Are According To DIN 746. Tolerances Are Based On The ISA-Fitting System Using k6 For Diameters Up To 50 mm And m6 For Diameters Above.
- (4) The Terminal Box Size Varies With Horsepower And Voltage.
- (5) The Terminal Box Can Be Placed On The Right Or Left, Dimensions Remain The Same.
- (6) Tolerance Of Dimensions Are According To DIN.
- (7) Tolerance for Flanges according to DIN 42948

Terminal Box Can Be Rotated For Lead Outlet At Top, Sides Or Bottom.  
Terminal Box Located On Opposite Side When F-1, W-2, W-3, W-6, W-8,  
Or C-2 Mounting Is Specified. Box Located On Top When Specified.  
Blower Assembly Can Be Located At Positions 1, 2, Or 4, Except  
Blower Assembly And Terminal Box Can Not Be Located At The Same Position.  
Motor Weight May Vary 15% For Non-Standard Ratings And/Or Accessories.  
If Mounting Clearance Details Are Required, Consult Factory.

# Industrial Direct Current Motors and Generators – RPM III

**ENCLOSURE:** Drip-Proof IP23

**COOLING:** Force Ventilated IC06, Air Filtered

**MOUNTING:** Flange Mounted

**ACCESSORIES:** Flange Mounted Tachometer

**METHOD OF DRIVE:** Coupled or Belted

## IEC TYPES GK1808Y THRU GK1810Y

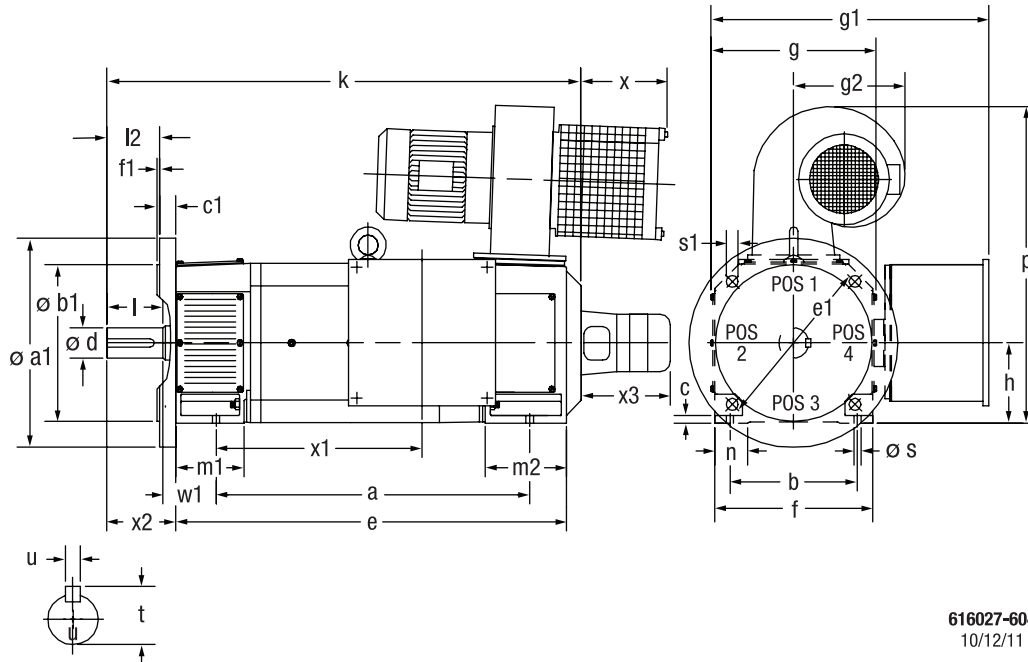

616027-604  
10/12/11

TYPE	DIN IEC	b A	c HA	f AB	g AC	g2 --	h H	n AA	p HD	s K	w1 C	a1 P	b1 N	c1 LA	e1 M	f1 T	s1 S
GK1808Y-UGK1810Y		279	17	358	364	235	180	75	667	15	202	400	300	15	350	5	19

TACH MODEL	x3
REO R1B	210
TDP 0,2T-4	220
TDP 0,2T-4+FSL	220
KGP 503.30	260
KGP 506.30	310
800123-2R	105
HOHNER 3000	170
845H	160

TYPE	DIN IEC	a B	e BB	k L	m1 BA	m2 --	x --	x2 --	DRIVE END SHAFT					WT. KG.
									d D	l E	l2 --	t GA	u F	
(U)GK1808Y		710	860	1148	172	234	162	202	70	140	140	74,5	20	429
(U)GK1810Y		790	999	1288	172	234	162	202	70	140	140	74,5	20	513

TYPE	DIN IEC	amps	x1 --	g1 --	CONDUIT SIZE
(U)GK1808Y		200	406	502	Pg36, Pg16
(U)GK1808Y		400	428	596	(2)
(U)GK1808Y		800	377	646	(2)
(U)GK1808Y		1600	352	646	(2)

TYPE	DIN IEC	amps	x1 --	g1 --	CONDUIT SIZE
(U)GK1808Y		200	546	502	Pg36, Pg16
(U)GK1808Y		400	568	596	(2)
(U)GK1808Y		800	517	646	(2)
(U)GK1808Y		1600	492	646	(2)

- (1) "h" Dimension Will Not Be Exceeded. Shims Up To .5 mm In Thickness Are Usually Required For Coupled Or Geared Machines.
- (2) Motor normally shipped with undrilled cable entry when over 200 amps
- (3) Shaft Extensions Are According To DIN 746. Tolerances Are Based On The ISA-Fitting System Using k6 For Diameters Up To 50 mm And m6 For Diameters Above.
- (4) The Terminal Box Size Varies With Horsepower And Voltage.
- (5) The Terminal Box Can Be Placed On The Right Or Left, Dimensions Remain The Same.
- (6) Tolerance Of Dimensions Are According To DIN.
- (7) Tolerance For Flanges According To DIN 42948

Terminal Box Can Be Rotated For Lead Outlet At Top, Sides Or Bottom.  
Terminal Box Located On Opposite Side When F-1, W-2, W-3, W-6, W-8,  
Or C-2 Mounting Is Specified. Box Located On Top When Specified.  
Blower Assembly Can Be Located At Positions 1, 2, Or 4, Except  
Blower Assembly And Terminal Box Can Not Be Located At The Same Position.  
Motor Weight May Vary 15% For Non-Standard Ratings And/Or Accessories.  
If Mounting Clearance Details Are Required, Consult Factory.

# Industrial Direct Current Motors and Generators – RPM III

**ENCLOSURE:** TOTALLY ENCLOSED IP44  
**METHOD OF DRIVE:** Coupled or Belted

**COOLING:** NON-VENTILATED IC410  
**MOUNTING:** Foot

## IEC TYPES GK1104 THRU ULGK1110

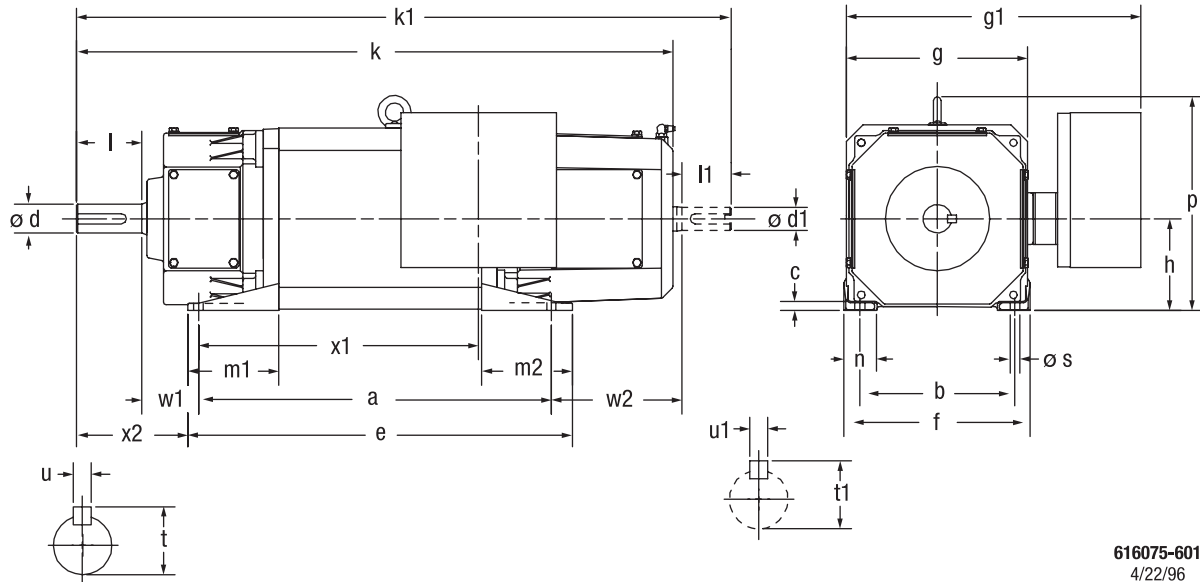

616075-601  
4/22/96

TYPE	DIN IEC	b A	c HA	f AB	g AC	h H	n AA	p HD	s K	w1 C
GK1104-GK1110		190	6	229	222	112	35	269	12	70

TYPE	DIN IEC	a B	e BB	k L	k1 LC	m1 BA	m2 —	x2 —	w2 CA	DRIVE END SHAFT				OPPOSITE DRIVE END SHAFT				WT. KG.
										d D	l E	t GA	u F	d1 DA	l1 EA	t1 GC	u1 FA	
GK1104		318	356	616	688	111	111	137	160	38	80	41	10	28	60	31	8	84
GK1106		356	394	655	726	111	111	137	160	38	80	41	10	28	60	31	8	93
GK1108		406	445	705	776	111	111	137	160	38	80	41	10	28	60	31	8	111
GK1110		432	471	731	802	111	111	137	160	38	80	41	10	28	60	31	8	120

TYPE	DIN IEC	amps	x1	g1	CONDUIT SIZE
GK1104		100	228	361	Pg29, Pg16

TYPE	DIN IEC	amps	x1	g1	CONDUIT SIZE
GK1106		100	266	361	Pg29, Pg16

TYPE	DIN IEC	amps	x1	g1	CONDUIT SIZE
GK1108		100	317	361	Pg29, Pg16

TYPE	DIN IEC	amps	x1	g1	CONDUIT SIZE
GK1110		100	343	361	Pg29, Pg16

- (1) "h" Dimension Will Not Be Exceeded. Shims Up To .5 mm In Thickness Are Usually Required For Coupled Or Geared Machines.
- (2) Motor normally shipped with undrilled cable entry when over 200 amps
- (3) Shaft Extensions Are According To DIN 746. Tolerances Are Based On The ISA-Fitting System Using k6 For Diameters Up To 50 mm And m6 For Diameters Above.
- (4) The Terminal Box Size Varies With Horsepower And Voltage.
- (5) The Terminal Box Can Be Placed On The Right Or Left, Dimensions Remain The Same.
- (6) Tolerance Of Dimensions Are According To DIN.

Terminal Box Can Be Rotated For Lead Outlet At Top, Sides Or Bottom.  
Terminal Box Located On Opposite Side When F-1, W-2, W-3, W-6, W-8,  
Or C-2 Mounting Is Specified. Box Located On Top When Specified.  
Blower Assembly Can Be Located At Positions 1, 2, Or 4, Except  
Blower Assembly And Terminal Box Can Not Be Located At The Same Position.  
Motor Weight May Vary 15% For Non-Standard Ratings And/Or Accessories.  
If Mounting Clearance Details Are Required, Consult Factory.

# Industrial Direct Current Motors and Generators – RPM III

**ENCLOSURE:** Totally Enclosed IP44, Guarded IP23  
**METHOD OF DRIVE:** Coupled or Belted

**COOLING:** Non-Ventilated IC410, Guarded IC01  
**MOUNTING:** Foot

## IEC TYPES GK1303 THRU GK1311

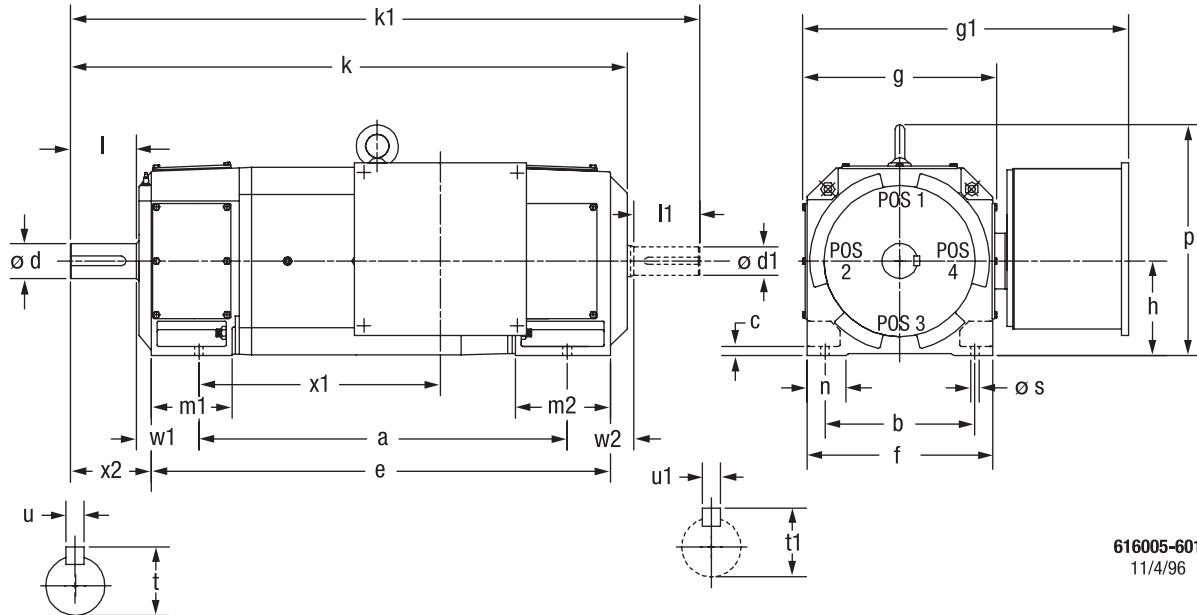

616005-601  
11/4/96

DIN TYPE	IEC	b	c	f	g	h	n	s	w1
		A	HA	AB	AC	H	AA	K	C
GK1303-GK1311		216	11	260	275	132	48	12	89

DIN TYPE	IEC	a	e	k	k1	m1	m2	p	x2	w2	DRIVE END SHAFT				OPPOSITE DRIVE END SHAFT				WT. KG.
											d	l	t	u	d1	l1	t1	u1	
GK1303		440	572	736	858	132	173	315	139	109	48	110	51,5	14	42	110	45	12	154
GK1305		490	603	767	890	132	173	315	139	91	48	110	51,5	14	42	110	45	12	166
GK1307		490	645	809	931	132	173	315	139	132	48	110	51,5	14	42	110	45	12	179
GK1309		540	676	840	963	132	173	315	139	114	48	110	51,5	14	42	110	45	12	191
GK1311		610	746	910	1033	132	173	315	139	114	48	110	51,5	14	42	110	45	12	215

DIN TYPE	IEC	amps	x1	g1	CONDUIT SIZE
GK1303		100	238	409	Pg29, Pg16
GK1303		200	225	423	Pg36, Pg16

DIN TYPE	IEC	amps	x1	g1	CONDUIT SIZE
GK1305		100	270	409	Pg29, Pg16
GK1305		200	257	423	Pg36, Pg16

DIN TYPE	IEC	amps	x1	g1	CONDUIT SIZE
GK1307		100	311	409	Pg29, Pg16
GK1307		200	298	423	Pg36, Pg16

DIN TYPE	IEC	amps	x1	g1	CONDUIT size
GK1309		100	343	409	Pg29, Pg16
GK1309		200	330	423	Pg36, Pg16

DIN TYPE	IEC	amps	x1	g1	CONDUIT size
GK1311		100	412	409	Pg29, Pg16
GK1311		200	400	423	Pg36, Pg16

- (1) "H" Dimension Will Not Be Exceeded. Shims Up To .5 Mm In Thickness Are Usually Required For Coupled Or Geared Machines.
- (2) Shaft Extensions Are According To DIN 746. Tolerances Are Based On The ISA-Fitting System Using k6 For Diameters Up To 50 mm And M6 For Diameters Above.
- (3) The Terminal Box Size Varies With Horsepower And Voltage.
- (4) The Terminal Box Can Be Placed On The Right Or Left, Dimensions Remain The Same.
- (5) Tolerance Of Dimensions Are According To DIN.
- (6) Opposite Drive End Shaft Supplied Only When Specified.

Terminal Box Can Be Rotated For Lead Outlet At Top, Sides Or Bottom.  
Terminal Box Located On Opposite Side When F-1, W-2, W-3, W-6, W-8, Or C-2 Mounting Is Specified. Box Located On Top When Specified.  
Blower Assembly Can Be Located At Positions 1, 2, Or 4, Except  
Blower Assembly And Terminal Box Can Not Be Located At The Same Position.  
Motor Weight May Vary 15% For Non-Standard Ratings And/Or Accessories.  
If Mounting Clearance Details Are Required, Consult Factory.

# Industrial Direct Current Motors and Generators – RPM III

**ENCLOSURE:** Totally Enclosed IP44  
**METHOD OF DRIVE:** Coupled or Belted

**COOLING:** Non-Ventilated IC410  
**MOUNTING:** Foot

## IEC TYPES GK1606 THRU GK1610

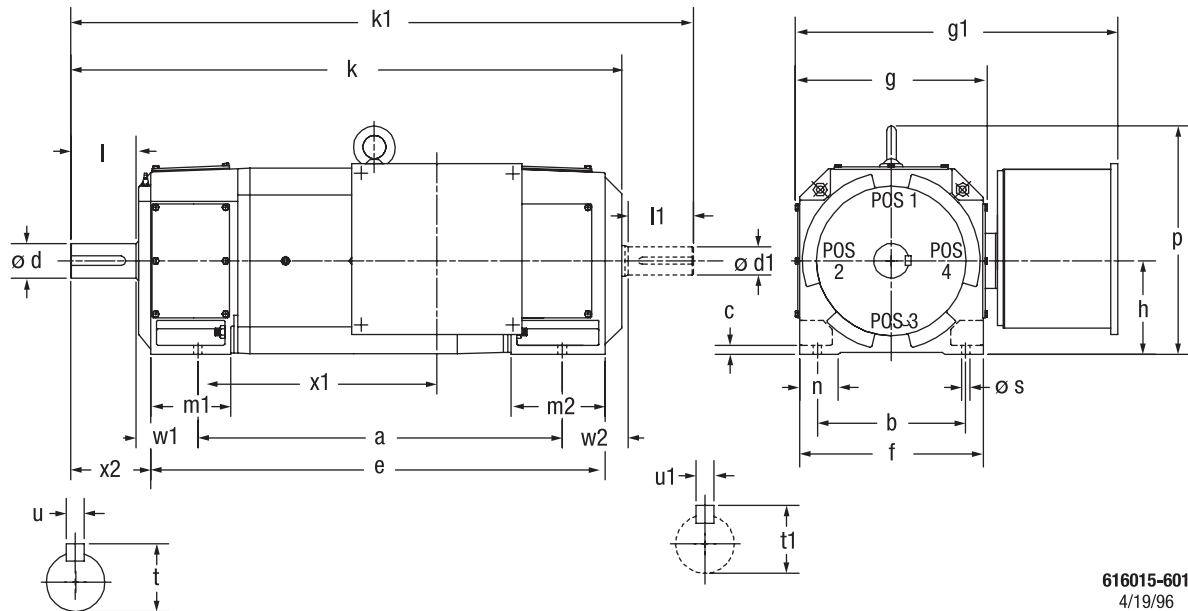

616015-601  
4/19/96

TYPE	DIN IEC	b A	c HA	f AB	g AC	h H	n AA	s K	w1 C
GK1606-GK1610		254	12	314	332	160	55	15	108

TYPE	DIN IEC	a B	e BB	k L	k1 LC	m1 BA	m2 —	p HD	x2 —	w2 CA	DRIVE END SHAFT				OPPOSITE DRIVE END SHAFT				WT. KG.
											d D	l E	t GA	u F	d1 DA	l1 EA	t1 GC	u1 FA	
GK1606		550	713	913	1036	154	203	380	172	128	60	140	64	18	48	110	51,5	14	274
GK1608		630	795	996	1119	154	203	380	172	126	60	140	64	18	48	110	51,5	14	313
GK1610		720	897	1098	1220	154	203	380	172	142	60	140	64	18	48	110	51,5	14	363

TYPE	DIN IEC	amps	x1 —	g1 —	CONDUIT SIZE
GK1606		100	334	453	Pg29, Pg16
GK1606		200	322	467	Pg36, Pg16
GK1606		400	339	560	(2)
GK1606		800	288	610	(2)

TYPE	DIN IEC	amps	x1 —	g1 —	CONDUIT SIZE
GK1608		100	416	453	Pg29, Pg16
GK1608		200	404	467	Pg36, Pg16
GK1608		400	421	560	(2)
GK1608		800	370	610	(2)

TYPE	DIN IEC	amps	—	g1 —	CONDUIT SIZE
GK1610		100	518	453	Pg29, Pg16
GK1610		200	506	467	Pg36 Pg16
GK1610		400	523	560	(2)
GK1610		800	472	610	(2)

- (1) "h" Dimension Will Not Be Exceeded. Shims Up To .5 mm In Thickness Are Usually Required For Coupled Or Geared Machines.
- (2) Shaft Extensions Are According To DIN 746. Tolerances Are Based On The ISA-Fitting System Using k6 For Diameters Up To 50 mm and m6 For Diameters Above.
- (3) The Terminal Box Size Varies With Horsepower And Voltage.
- (4) The Terminal Box Can Be Placed On The Right Or Left, Dimensions Remain The Same.
- (5) Tolerance Of Dimensions Are According To DIN.
- (6) Opposite Drive End Shaft Supplied Only When Specified.

Terminal Box Can Be Rotated For Lead Outlet At Top, Sides Or Bottom.  
Terminal Box Located On Opposite Side When F-1, W-2, W-3, W-6, W-8,  
Or C-2 Mounting Is Specified. Box Located On Top When Specified.  
Blower Assembly Can Be Located At Positions 1, 2, Or 4, Except  
Blower Assembly And Terminal Box Can Not Be Located At The Same Position.  
Motor Weight May Vary 15% For Non-Standard Ratings And/Or Accessories.  
If Mounting Clearance Details Are Required, Consult Factory.



**Industrial Direct Current Motors and Generators – RPM III**

**ENCLOSURE:** Totally Enclosed IPR44

**COOLING:** Separately Force Ventilated IC37

**MOUNTING:** Foot

**IEC TYPES GK2806 THRU GK2810**

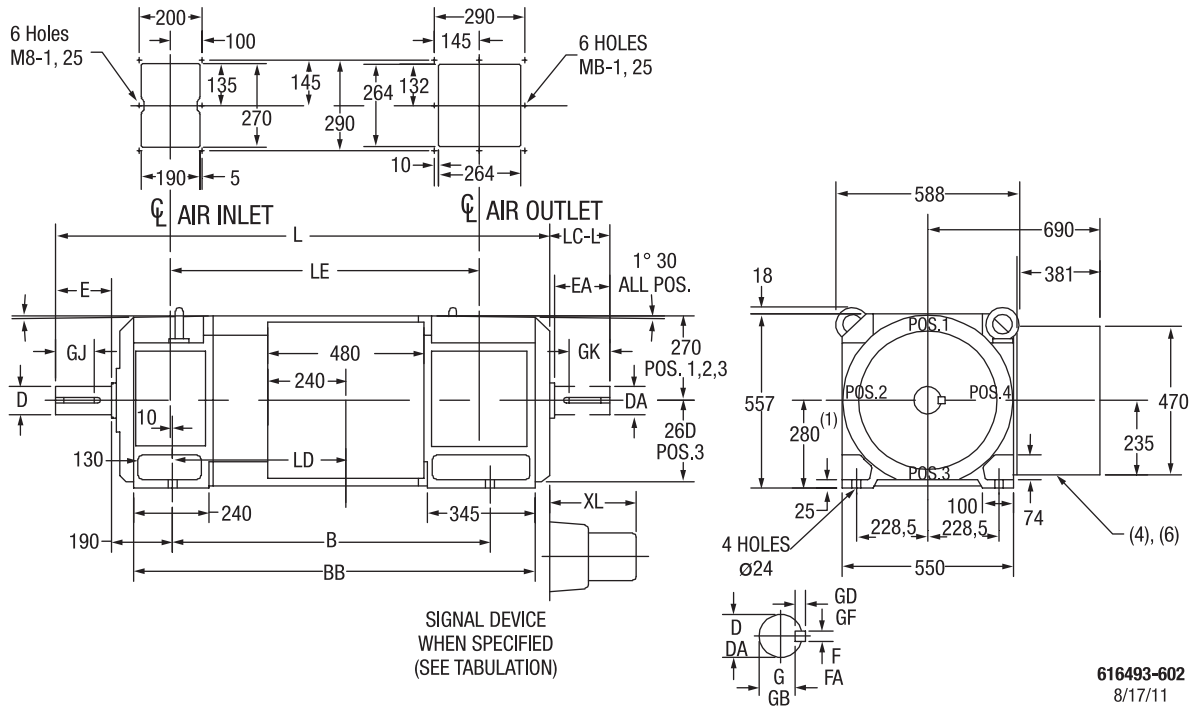

616493-602  
8/17/11

**DIMENSIONS ARE IN MILLIMETERS**

FRAME	L	LD	LE	BB	B	DRIVE END SHAFT AND KEY						<sup>(5)</sup> OPPOSITE DRIVE END SHAFT AND KEY						WT. (KG.)	
						D <sup>(2)</sup>	E	F	G <sup>(3)</sup>	GD	GJ	LC-L	DA <sup>(2)</sup>	EA	FA	GB <sup>(3)</sup>	GF		GK
GK2806	1507	503	879	1184	900	100	210	28	90	16	165	180	80	170	22	71	14	154	1394
UGK2806	1507	503	879	1184	900	110	210	28	90	16	165	180	80	170	22	71	14	154	1394
GK2808	1607	603	979	1284	1000	100	210	28	90	16	165	180	80	170	22	71	14	154	1583
UGK2808	1607	603	979	1284	1000	110	210	28	90	16	165	180	80	170	22	71	14	154	1583
GK2810	1767	763	1139	1444	1160	100	210	28	90	16	165	180	80	170	22	71	14	154	1864
UGK2810	1767	763	1139	1444	1160	110	210	28	90	16	165	180	80	170	22	71	14	154	1864

SIGNAL DEVICE	XL	WT. (KG.)
5PY	276	3, 2
BC-42	340	11, 4
BC46	398	15, 9
M-627A	267	6, 4
M-628A	267	6, 4
M-727A	267	6, 4

SIGNAL DEVICE	XL	WT. (KG.)
M-737A	267	6, 4
RD-11	254	7, 7
RD-51	424	17, 2
RD-61	254	7, 7
RD-62	254	7, 7
RE-045	65	2, 3

SIGNAL DEVICE	XL	WT. (KG.)
RE-210	389	13, 6
TG2168A	65	2, 3
TS2014N	165	2, 3
TS2087N	279	6, 4
AVTRON M3	102	6, 4

(1) This Dimension Will Not Be Exceeded. Shims Up To 1,5mm In Thickness Are Usually Required For Coupled Or Geared Machines.  
 (2) "D" And "DA" Vary -0,025  
 (3) "G" And "GB" Vary -0,38  
 (4) Removable Cover Plate For Customer Drilling. Terminal Box Can Be Positioned For Either Top Or Bottom Conduit Entry  
 (5) Opposite Drive End Shaft Supplied Only When Specified  
 (6) Terminal Box Located On Opposite Side When Specified

## Modifications Index

Modifications are listed in alphabetical order by major topic heading. This index provides a cross-reference to enable you to find specific modifications.

A complete description of the features of standard DC motors is given in General Information Section.

Modifications in this section are to be added to the basic motor when features not included on the standard motor are required.

Addition of certain modifications may cause the frame size to increase.

<b>Modification</b>	<b>Mod No.</b>	<b>Page</b>
Air Pressure Switch.....	134	122
Altitude – 1001-2680 m. ....	101	121
Ambient Temperature – High.....	105	121
– Low.....	106-108	121
Application Data (Refer to Technical Description Section)....	—	—
<hr/>		
Balance, Special		
Grade “R” .....	112	121
Grade “S” .....	113	121
Bases – Heavy Duty .....	121	121
Bearings Insulated .....	125	121
Belted Drive – Reinforced Bearing .....	126	121
Blowers, Motor Mounted .....	130	121
Brackets, IM B35 .....	140	122
Brakes, Disc Type .....	150	122
Brush Wear Sensors .....	155A, 155B	122
<hr/>		
Coupling, Mounting of Customer’s .....	177-178	123
<hr/>		
DC Tachometers .....	355-359	124
Double Shaft Extension .....	269	123
Dust-Proof Features – IP55 .....	183A	123
<hr/>		
Enclosures:		
Separately Ventilated .....	183	123
Dust-Proof IP55 .....	183A	123
Encoder .....	545-561	124
ESP Brushes .....	155A	122
<hr/>		
Field Winding – Series .....	224	123
Filter on Motor Mounted Blower .....	131	122
Finish, Special Color .....	240	123
Force Ventilated Enclosure .....	244	123
<hr/>		
Gear Motor – Mounting of Customer’s .....	244	123
<hr/>		
Insulated Bearings .....	125	121

<b>Modification</b>	<b>Mod No.</b>	<b>Page</b>
Overspeed Switch .....	355A	124
Overtemperature Protection .....	410-418	125-126
<hr/>		
Paint, Special .....	240	123
Provision for Mounting Tachometer .....	317	124
<hr/>		
Resistance Temperature Detector .....	418	126
Resolver .....	544	124
Roller Bearing – Drive End .....	126	121
<hr/>		
Separately Ventilated Enclosures .....	183	123
Series Field .....	224	123
Shaft Modifications		
Drive End – NEMA .....	272A	123
Face Type Seal .....	276	123
Lip type Seal .....	275	123
Non-Standard Diameter .....	272-273	123
Non-Standard Length .....	274	123
Shaft Guard .....	271	123
Standard Non-Drive End Extension .....	269	123
Standard NEMA Non-Drive End .....	269A	123
Steps .....	277	124
Tapered .....	279	124
Threads .....	278	124
Shunt Field – Second .....	226	123
Slide Bases .....	121	121
Space Heater – Motor Mounted .....	280	124
Speed Limit Switch .....	355A	124
<hr/>		
Tachometer Generators		
DC .....	355-359	124
Encoders .....	545-546	124
Resolvers .....	544	124
Provision for Mounting .....	317	124
Temperature, Higher than Standard .....	105	121
Temperature, Lower than Standard .....	106-108	121
Tests .....	450-453	127
Thermistors .....	412-413	126
Thermostat .....	410-411	125-126
<hr/>		
Vibration Proved Design .....	440	126
Voltage, Special Blower Motor .....	130A	121

## Modifications

Mod. No.	Modification
	<b>ALTITUDE</b> Standard guarantees are made on the basis that the motor will operate at an altitude from sea level to 1000 m per IEC 34-1.
101	<b>For machines suitable for operation at altitudes 1001–2680 m – Applicable to all enclosures.</b>
	<b>AMBIENT TEMPERATURE</b>
105	<b>For motors suitable for operation in ambients greater than 40°C.</b> Note: Frame size may change. Refer to Baldor Electric. <span style="float: right;"><b>AMBIENT</b> 41°C - 60°C 65°C</span>
	<b>MODIFICATION</b> Motors suitable for operation in low ambient temperatures. Note: Base speeds and regulation may not be in accordance with IEC standards. Motors should have space heater (Mod. 280) added to prevent condensation of moisture when unenergized.
106	<b>Motors suitable for operation in ambients as low as –25°C.</b> Special brushes provided as required.
107	<b>Motors suitable for operation in ambients as low as –40°C.</b> Low temperature grease, special brushes, and high tensile strength shaft material provided as required.
108	<b>Motors suitable for operation in ambients as low as – 60°C.</b> Low temperature grease, special brushes, high tensile strength shaft material, special commutator, provided as required.
	<b>BALANCE – SPECIAL</b>
112	Grade “R”
113	Grade “S” Standard balance is normally equivalent to vibration grade N according to DIN ISO 2373. (Rotors are dynamically balance with inserted key.) For increased requirements on mechanical balancing, vibration grade R or S can be achieved by the addition of these modifications. Refer to Technical Description section for limiting values of vibration velocity.
	<b>BASES</b> <b>For adjusting belt tension. Bases are not suitable for wall or ceiling mounting.</b>
121	<b>Base-Heavy Duty</b> – Two adjusting Bolts
125	<b>INSULATED BEARINGS</b> Add for insulated bearings.
126	<b>REINFORCED BEARING</b> Provides for roller bearings on drive end and special shaft on frames 180 thru 280 DC used for belted drive. Refer to the Technical Description section for radial load capacity. Details of the drive system must accompany the order. Belted drive applications not meeting the standard minimum sheave diameters, etc., require special pricing. Refer to Mod. 177 for mounting of customer’s finished bore sheave.
130	<b>BLOWER WITHOUT FILTER</b> Standard DC ratings are based on pipe-ventilation with the motor cooled by customer supplied air with the air inlet on the non-drive side (commutator side) and the outlet air leaves the motor via the louvres on the drive side. Note: For the 280 frame, air inlet is at the drive end and air outlet is at the opposite drive end. Addition of this modification BLOWER WITHOUT FILTER – provides a blower mounted on the non-drive side. The blower is mounted on top or to one side. Since the blower motor operates at constant speed the cooling air is independent of DC motor speed. To insure adequate protection against cooling air loss, protective devices, e.g. thermistors, thermostats or air pressure switch are recommended. The AC blower motor is rated 380–420 volts/50 Hz. For other blower motor ratings, add as follows:
130A	<b>440–480 VOLTS/60 HZ</b> <span style="float: right;"><b>Standard for frames 112–160</b></span> Other Special Voltages <span style="float: right;">Refer to Application Engineer – Baldor Electric Company</span>

## Modifications

Mod. No.	Modification															
131	<p><b>FILTER ADDITION</b> Filter Addition for DPG-FV motor with motor mounted blower. Filter is washable type. Recommended when filterable contaminants are present. Totally enclosed construction rather than blower with filter is recommended for extremely dusty, dirty locations.</p>															
	<p><b>AIR PRESSURE SWITCH – TYPE 625</b> – Mounted on motor bracket at air inlet end Monitors pressure inside of motor to actuate SPDT switch when pressure drops below preset value giving an immediate indication that the air supply to the motor is reduced. Applicable to forced ventilated motors with either motor mounted blower or separately forced ventilated by customer supplied air. Since motors dependent on force ventilation will have a rapid rise in temperature after the air supply is interrupted, the customer must take immediate corrective action when the switch trips. Pressure switch is of single pole design for 220 volts. 1 amp provided with n.o. and n.c. contacts.</p>															
134	<p><b>Type 625 – Switch with standard enclosure</b> – motor mounted <b>BRACKETS</b> – Type of Construction IEC D-flange with standard dimensions.</p>															
140	<p>IM B35(B3/B5) D-Flange IM V1 (Vert Shaft Down with D-Flange) Others <span style="float: right;">Refer to Application Engineer – Baldor Electric Company</span></p>															
150	<p><b>BRAKE MOUNTING</b> <b>Standard Brakes</b> <b>Non-Standard Brakes</b> <span style="float: right;">Refer to Application Engineer – Baldor Electric Company</span></p>															
150A	<p><b>Single Disc Brakes (STROMAG)</b> <b>Does not include mounting.</b> <b>Add for Mounting Brake – See Modification 150.</b></p> <table border="1" style="margin-left: auto; margin-right: auto;"> <thead> <tr> <th style="text-align: center;">Type</th> <th style="text-align: center;">Supply</th> <th style="text-align: center;">Torque Range NM</th> </tr> </thead> <tbody> <tr> <td style="text-align: center;">SMB5</td> <td style="text-align: center;">24 or 90 V. DC</td> <td style="text-align: center;">Up to 50</td> </tr> <tr> <td style="text-align: center;">SMB10</td> <td style="text-align: center;">24 or 90 V. DC</td> <td style="text-align: center;">60 to 100</td> </tr> <tr> <td style="text-align: center;">SMB20</td> <td style="text-align: center;">24 or 90 V. DC</td> <td style="text-align: center;">130 to 200</td> </tr> <tr> <td style="text-align: center;">SMB30</td> <td style="text-align: center;">24 or 90 V. DC</td> <td style="text-align: center;">240 to 265</td> </tr> </tbody> </table>	Type	Supply	Torque Range NM	SMB5	24 or 90 V. DC	Up to 50	SMB10	24 or 90 V. DC	60 to 100	SMB20	24 or 90 V. DC	130 to 200	SMB30	24 or 90 V. DC	240 to 265
Type	Supply	Torque Range NM														
SMB5	24 or 90 V. DC	Up to 50														
SMB10	24 or 90 V. DC	60 to 100														
SMB20	24 or 90 V. DC	130 to 200														
SMB30	24 or 90 V. DC	240 to 265														
150B	<p><b>Brake Modifications for Brakes in Mod 150A.</b></p> <table border="1" style="margin-left: auto; margin-right: auto;"> <tr> <td> <p><b>Adjustable Torque</b> Type SMB5 Type SMB10 Type SMB20 Type SMB30 Micro Switch Rectifier for Operation on 230 V 50 Hz Manual Release</p> </td> </tr> </table>	<p><b>Adjustable Torque</b> Type SMB5 Type SMB10 Type SMB20 Type SMB30 Micro Switch Rectifier for Operation on 230 V 50 Hz Manual Release</p>														
<p><b>Adjustable Torque</b> Type SMB5 Type SMB10 Type SMB20 Type SMB30 Micro Switch Rectifier for Operation on 230 V 50 Hz Manual Release</p>																
	<p><b>BRUSH WEAR SENSOR</b></p>															
155A	<p><b>Non-Potential Free</b> – Add for ESP™ brushes and current isolation network installed in motor with special leads terminated in a conduit box. (1) Provides output from motor when brushes wear to a predetermined length. Signal gives indication of brush wear so that corrective action may be taken to prevent malfunction of the motor and possible damage to the commutator from worn brushes. The voltage signal is the same magnitude as the motor armature voltage. <span style="float: right;">Frames 112–180 Frames 200–250 Frame 280</span></p> <p>(1) <b>NOTE:</b> Does not include control monitor. Signal return isolation network is usually mounted in control cabinet but may be mounted in motor conduit box when specified for an additional adder.</p>															
155B	<p><b>Potential Free</b> – Two brushholders with microswitch <span style="float: right;">Frames 112–180 Frames 200–250 Frame 280</span></p>															
156	<p><b>BRUSHES AND BRUSHHOLDERS FOR AGGRESSIVE ATMOSPHERES</b></p>															

## Modifications

Mod. No.	Modification
	<b>COUPLING – MOUNTING ON MOTOR</b>
177	<b>Mounting of customer's <i>finished</i> bore coupling on motor shaft.</b> Finished bore coupling must be received at plant five weeks prior to shipment with customer property tag attached.
178	<b>Mounting of customer's <i>unfinished</i> bore coupling on motor shaft.</b> Unfinished bore coupling must be received at plant five weeks prior to shipment with customer property tag attached.
	<b>ENCLOSURES</b>
183	<b>SEPARATELY VENTILATED IC 17 IC37</b> <span style="float: right;"><b>Standard</b></span>
183A	<b>IP55, Dust-Tight Features Additional seals and gaskets</b>
	<b>FIELD WINDINGS</b>
224	<b>Series Field</b> <div style="border: 1px solid black; padding: 5px; margin-top: 10px;"><b>WARNING: Series wound motors must be solidly connected to the driven machine and never operated without load to avoid possible destructive high speeds. The speed of a series motor is defined only at rated load.</b></div>
226	<b>Second Shunt Field</b>
	<b>FINISH</b>
240	<b>Special Color</b> Special color. Refer to General Information Section for description of standard finish.
241	<b>Improved Corrosion Protection</b>
	Refer to Application Engineer – Baldor Electric Company.
244	<b>MOUNTING OF CUSTOMER SUPPLIED GEAR BOX</b> Add Mod. 244 plus D-Flange, special shaft, Lip Seal, etc. as required.
	<b>SHAFT MODIFICATIONS</b>
269	<b>Standard Non-Drive End Shaft</b> Commutator end extension having dimensions per the standard dimension sheets. <b>NOTE:</b> Not for suitable tandem motor operation. If tandem motors are required, contact Baldor Electric.
269A	<b>Non-Drive End NEMA</b>
271	<b>Shaft Guard</b> Provides a protective cover over front end shaft extensions. <div style="border: 1px solid black; padding: 5px; margin-top: 10px;"><b>WARNING: To prevent injury, shaft guard must be specified or supplied by customer for exposed shaft extensions.</b></div>
272	<b>Special Shaft Diameter – Drive End</b>
272A	<b>Drive End NEMA – n.e.ch.</b>
273	<b>Special Shaft Diameter – Opposite Drive End</b>
274	<b>Special Shaft Length</b> Non-standard length for either drive end or opposite drive end shaft (use twice modification adder for non-standard length on both ends). Maximum length limited to two times standard length. <div style="border: 1px solid black; padding: 5px; margin-top: 10px;"><b>CAUTION: Belted drives using smaller than standard diameter shafts and/or longer than standard shafts must be referred to Baldor Electric with complete belt drive data.</b></div>
275	<b>Shaft – Lip Seal</b> This modification provides a lip seal on the drive end to protect the bearing when operated with oil splashing against the shaft. Typical application is on a horizontal motor mounted to a gear case where the stationary oil level is below the motor shaft. Seals operated dry for extended periods will be damaged.
276	<b>Shaft – Face Seal</b> This modification provides a face seal on the drive end to protect the bearing when operated with a head of oil against the shaft. Typical application is a vertical shaft-up motor connected to a gear case with oil against the motor shaft. Seals operated dry for extended periods will be damaged.

## Modifications

Mod. No.	Modification
277	<b>Shaft Step</b> Each step or reduced diameter from standard straight shaft. Thread modification No. 278 is usually required with this Mod.
278	<b>Shaft Threads</b> Class 2A right hand thread of size compatible with shaft diameter. Step modification No. 277 is usually required with this Mod.
279	<b>Shaft Tapered</b> Provides standard NEMA AC shaft tapered 1-1/4 inches per foot. May be added for either drive end or opposite drive end shaft extension. Includes threads, washer and locknut. Specify "U" or "FU" required.
280	<b>SPACE HEATERS</b> Mounted inside the motor. Recommended to prevent condensation of moisture for motors remaining unenergized for long periods of time. Standard heater is single-phase 220-240 volts, 50/60 Hz. Leads are terminated in motor conduit box. Refer to Technical Description section for space heater ratings.
<b>TACHO MOUNTING PROVISIONS ONLY</b>	
317	Standard for above mentioned tachos including stub shaft, adapter, coupling.
<b>DC TACHO GENERATOR INCLUDING MOUNTING</b>	
355	<b>TDP 0,2LT-4 (HUBNER)</b>
355A	<b>DC TACHO GENERATOR/SPEED LIMIT SWITCH – COMBINATION TDPO-2LT-4 WITH INTEGRAL OVERSPEED SWITCH – n = 1950 RPM (HUBNER)</b>
356	<b>BALDOR XPYII 60/1000 RPM</b>
<b>DC TACHO GENERATOR (BEARINGLESS, BRACKET MOUNTED) MOUNTING INCL.</b>	
359	<b>TDPO,51/42 REPLACED BY GTR 9.16L/420 (HUBNER)</b>
544	<b>RESOLVER, MOUNTING INCL.</b> 800123-2R
545	<b>ENCODER, MOUNTING INCL.</b> HOHNER 3000 (SERIES 30)
546	<b>OPTICAL ENCODER, MTG INCL.</b> HEIDENHAIN ROD 436 1000, 1024 OR 2048 PPR
560	<b>DYNAPAR HS35R</b> Direct shaft mounted, hollow shaft, sealed (IP66) No coupling or adapter required with MS connector, bidirectional (Quadrature), Differential output, with marker pulse. PPR: 512, 1024, 2048, 4096. Max 5–26 volt, single output.
561	<b>Litton G71 encoder</b> MS connector, bi-directional (quadrature) differential output marker pulse, 5 volt or 8–30 volt, single output, IP64.
—	Non-Standard Tachos <span style="float: right;">Refer to Application Engineer – Baldor Electric Company</span>

## Modifications

Mod. No.	Modification
<b>MOTOR OVERTEMPERATURE PROTECTION</b>	
<p>Overtemperature protection of the various windings in a direct-current motor, especially the armature winding which rotates, is considerably complex. The wide range of load and speed (ventilation) in the typical direct-current motor application adds to the difficulty. Current-sensing devices located remotely from the motor (frequently in control panels) cannot match the thermal characteristics of direct-current motors over a wide speed range because of these variable motor cooling conditions. Baldor Electric offers several modifications to protect the DC motor against overtemperature operation as follows: (Refer to each modification for complete description and limitations.)</p>	
<b>Mod. No.</b>	<b>Modification</b>
<b>410</b>	High Limit Thermostat on Intercoil
<b>411</b>	Warning Thermostat on Intercoil
<b>132/133</b>	Air Pressure Switch
<b>412/413/414</b>	Thermistors on Intercoil
<b>415/416/417</b>	Thermistors on Main Field Winding
<b>418</b>	Resistance Temperature Detector on Intercoil
<b>410</b>	<b>HIGH LIMIT THERMOSTAT ON INTERCOIL</b> – with leads brought into the standard conduit box.
<p>The thermostat normally closed contact is suitable for use in control circuits rated 120–500 volts AC, 1100 volt-amps.</p> <p style="text-align: center;"><b>Protects Against</b></p> <ul style="list-style-type: none"> <li>• High load operation of force ventilated (IC06) motors at all speeds except very low speeds.</li> <li>• High load operation of IC410 (TENV) motors.</li> <li>• Operation in extremely high ambient temperatures.</li> <li>• After a time delay, gives indication of complete loss of cooling air.</li> </ul> <p style="text-align: center;"><b>Advantages</b></p> <ul style="list-style-type: none"> <li>• Low cost.</li> <li>• Operates directly into control circuit.</li> </ul> <p style="text-align: center;"><b>Disadvantages</b></p> <ul style="list-style-type: none"> <li>• Size of unit makes placement of windings critical to obtain good thermal contact.</li> <li>• Does not provide dependable protection on force ventilated motors with overloads at low motor speeds. At low speeds the heat dissipating ability of the armature is reduced due to decrease in armature velocity while the heat dissipating ability of the stationary intercoil, where the thermostat is located, remains constant.</li> <li>• Since intercoil thermal time constant is typically five times longer than the armature thermal time constant, extremely high short-term armature overloads may damage the armature before the thermostat trips or permit the motor to be operated at higher than normal rated temperature rise resulting in less than normal motor insulation life. Other load limiting devices in the control-thermal overload relays or instantaneous over-current relays must be used to protect the motor.</li> </ul>	

## Modifications

Mod. No.	Modification
411	<p><b>WARNING THERMOSTAT ON INTERCOIL</b> <span style="float: right;">For motor warning thermostat with N/C contacts, (Refer to MOD. 410 for contact rating)</span></p> <p>(MOD. 410 must also be added with this MOD.)</p> <p>Provides low temperature thermostat on the intercoil with leads brought into the standard conduit box. This thermostat, selected to trip approximately 15°C below the high limit thermostat, may be used as a warning signal to indicate the intercoil temperature is approaching a high temperature. The same advantages and limitations as outlined in MOD. 410 apply to this thermostat. Under certain operating conditions – extremely low speed operation of forced ventilated motor or extremely high short-term overloads – the motor may be damaged before the high limit thermostat trips. If the condition of the overload is determined to be due to these operating conditions, the tripping of the warning thermostat should be used to shut down the drive, thus preventing possible damage to the motor by continued operation. In actual operation, the exact cause of the low temperature thermostat tripping may be difficult to determine although tripping of this warning thermostat can be used as a signal to check drive operation.</p> <p><b>NOTE:</b> The usefulness of a warning thermostat is limited since the time between activation of the warning thermostat is a function of load, ambient temperature, and other factors and cannot be predetermined.</p>
	<p><b>THERMISTORS</b></p> <p>(Quantity 3) 2 on intercoil and 1 on field coil.</p> <p>Offers the same functional protection as a thermostat but with the advantage of a smaller solid state sensing device to obtain better thermal contact with windings. The PTC thermistor bonded to the intercoil provides an approximate 20:1 increase in resistance when it reaches its trip temperature. This change in resistance is detected by an electronic module external to the motor. Module must be priced separately.</p> <p>Protection limitations for thermistors are similar to thermostat for various operating conditions. Refer to MOD. 410.</p>
412	<b>HIGH LIMIT THERMISTORS</b>
413	<b>WARNING THERMISTORS</b>
	<p><b>THERMISTORS</b></p> <ul style="list-style-type: none"> <li>• (Quantity 3) 2 on intercoil and 1 on field coil.</li> <li>• Additional protection can be obtained by monitoring main field winding temperature with thermistors. Possible causes of excessive field temperature are as follows:             <ol style="list-style-type: none"> <li>1. Loss of cooling air on motors designed for forced ventilation as standard.</li> <li>2. High field voltage over 110% rated.</li> </ol> </li> <li>• The PTC thermistor bonded to the field winding provides an approximate 20:1 increase in resistance when it reaches its “Trip” temperature. This change in resistance is detected by an electronic module external to the motor. Module must be priced separately.</li> </ul>
418	<p><b>RESISTANCE TEMPERATURE DETECTOR (RTD) –</b> <span style="float: right;">For 100 ohm 3-wire platinum Resistance Temperature Detector mounted on intercoil with leads wired to terminal board in conduit box.</span></p> <p>This modification provides a 100 ohm RTD on the intercoil winding to permit monitoring the intercoil winding temperature with a customer supplied instrument giving an analog indication of intercoil thermal rise. This information is useful in checking intercoil temperature; however, the same limitations on relating this temperature to actual temperature apply with an RTD as with a thermostat (See Mod. 410).</p>
440	<b>Vibration Proved Design</b>
	<p>For motors exposed to above normal shock or vibration. Modification provides special wire and banding, TIG welded commutators, extra dips and bakes, and lock washers on bolts.</p>



## Modifications

Mod. No.	Modification
<b>TESTS</b>	
<b>450</b>	<p><b>Routine Test</b> – Certified copy of Test Report – This modification provides up to five (5) copies of the certified test report containing the data on the standard routine test per IEEE Standard 113 that is given each motor. This test provides assurance that the motor meets design specifications. The routine test consists of:</p> <ol style="list-style-type: none"> <li>1. Neutral check</li> <li>2. Shunt field wiring resistance check</li> <li>3. Commutation check</li> <li>4. High potential check</li> <li>5. Motor operation under following conditions with speed, voltage and current checked               <ol style="list-style-type: none"> <li>a. No load at rated voltage at base speed and maximum field weakened speed</li> <li>b. Full load at rated voltage at base speed and maximum field weakened speed</li> </ol> </li> </ol> <p><b>Note:</b> All motors are subjected to routine test; however, test data is not recorded and submitted to customer unless this modification is specified.</p>
<b>451</b>	<p><b>Witnessed Routine Test</b> – The routine test described above to be witnessed by customer. Customer will be notified approximately 2 days before motor is ready for test. Includes six certified copies of test report.</p> <p style="padding-left: 20px;">Witnessed Routine Test – GK112 thru GK180</p> <p style="padding-left: 20px;">Witnessed Routine Test – GK200 thru GK250</p> <p style="padding-left: 20px;">Witnessed Routine Test – GK280</p>
<b>452</b>	<p><b>Performance Test</b> – Provides complete motor performance test and heat run on dynamometer with motor horsepower, speed, torque and efficiency recorded as a function of armature current up to 150% of rated armature current. Includes six certified copies of test report.</p> <p style="padding-left: 20px;">Performance Test – GK112 thru GK180</p> <p style="padding-left: 20px;">Performance Test – GK200 thru GK250</p> <p style="padding-left: 20px;">Performance Test – GK280</p>
<b>453</b>	<p><b>Witnessed Performance Test</b> – Performance test witnessed by customer. Customer will be notified approximately 2 days before motor is ready for test. Includes six (6) certified copies of test report.</p> <p style="padding-left: 20px;">Witnessed Performance Test – GK112 thru GK180</p> <p style="padding-left: 20px;">Witnessed Performance Test – GK200 thru GK250</p> <p style="padding-left: 20px;">Witnessed Performance Test – GK280</p>

## **Modifications**

<b>Mod. No.</b>	<b>Modification</b>



## Contact your nearest Baldor District Office at these World Wide locations, or visit [www.baldor.com](http://www.baldor.com)

### UNITED STATES

#### ARIZONA PHOENIX

4211 S 43RD PLACE  
PHOENIX, AZ 85040  
PHONE: 602-470-0407  
FAX: 602-470-0464

#### ARKANSAS

**CLARKSVILLE**  
1001 COLLEGE AVENUE  
CLARKSVILLE, AR 72830  
PHONE: 479-754-9108  
FAX: 479-754-9205

#### CALIFORNIA LOS ANGELES

6480 FLOTTILLA STREET  
COMMERCE, CA 90040  
PHONE: 323-724-6771  
FAX: 323-721-5859

#### HAYWARD

21056 FORBES AVENUE  
HAYWARD, CA 94545  
PHONE: 510-785-9900  
FAX: 510-785-9910

#### COLORADO

**DENVER**  
3855 FOREST STREET  
DENVER, CO 80207  
PHONE: 303-623-0127  
FAX: 303-595-3772

#### CONNECTICUT

**WALLINGFORD**  
65 SOUTH TURNPIKE ROAD  
WALLINGFORD, CT 06492  
PHONE: 203-269-1354  
FAX: 203-269-5485

#### FLORIDA

**TAMPA/PUERTO RICO/  
VIRGIN ISLANDS**  
3906 EAST 11TH AVENUE  
TAMPA, FL 33605  
PHONE: 813-248-5078  
FAX: 813-247-2984

#### GEORGIA

**ATLANTA**  
62 TECHNOLOGY DRIVE  
ALPHARETTA, GA 30005  
PHONE: 770-772-7000  
FAX: 770-772-7200

#### ILLINOIS

**CHICAGO**  
340 REMINGTON BLVD.  
BOLINGBROOK, IL 60440  
PHONE: 630-296-1400  
FAX: 630-226-9420

#### INDIANA

**INDIANAPOLIS**  
5525 W. MINNESOTA STREET  
INDIANAPOLIS, IN 46241  
PHONE: 317-246-5100  
FAX: 317-246-5110

#### IOWA

**DES MOINES**  
1800 DIXON STREET, SUITE C  
DES MOINES, IA 50316  
PHONE: 515-263-6929  
FAX: 515-263-6515

#### MARYLAND

**BALTIMORE**  
6660 SANTA BARBARA RD.  
SUITES 22-24  
ELKCRIDGE, MD 21075  
PHONE: 410-579-2135  
FAX: 410-579-2677

#### MASSACHUSETTS

**BOSTON**  
6 PULLMAN STREET  
WORCESTER, MA 01606  
PHONE: 508-854-0708  
FAX: 508-854-0291

#### MICHIGAN

**DETROIT**  
5933 PROGRESS DRIVE  
STERLING HEIGHTS, MI 48312  
PHONE: 586-978-9800  
FAX: 586-978-9969

#### MINNESOTA

**MINNEAPOLIS**  
21080 134TH AVENUE NORTH  
ROGERS, MN 55374  
PHONE: 763-428-3633  
FAX: 763-428-4551

#### MISSOURI

**ST LOUIS**  
13678 LAKEFRONT DRIVE  
EARTH CITY, MO 63045  
PHONE: 314-373-3032  
FAX: 314-373-3038

#### KANSAS CITY

1501 BEDFORD AVENUE  
NORTH KANSAS CITY, MO 64116  
PHONE: 816-587-0272  
FAX: 816-587-3735

#### NEW YORK

**AUBURN**  
ONE ELLIS DRIVE  
AUBURN, NY 13021  
PHONE: 315-255-3403  
FAX: 315-253-9923

#### NORTH CAROLINA

**GREENSBORO**  
1220 ROTHERWOOD ROAD  
GREENSBORO, NC 27406  
PHONE: 336-272-6104  
FAX: 336-273-6628

#### OHIO

**CINCINNATI**  
2929 CRESCENTVILLE ROAD  
WEST CHESTER, OH 45069  
PHONE: 513-771-2600  
FAX: 513-772-2219

#### CLEVELAND

8929 FREEWAY DRIVE  
MACEDONIA, OH 44056  
PHONE: 330-468-4777  
FAX: 330-468-4778

#### OKLAHOMA

**TULSA**  
7170 S. BRADEN, SUITE 140  
TULSA, OK 74136  
PHONE: 918-366-9320  
FAX: 918-366-9338

#### OREGON

**PORTLAND**  
20393 SW AVERY COURT  
TUALATIN, OR 97062  
PHONE: 503-691-9010  
FAX: 503-691-9012

#### PENNSYLVANIA

**PHILADELPHIA**  
1035 THOMAS BUSCH  
MEMORIAL HIGHWAY  
PENNSAUKEN, NJ 08110  
PHONE: 856-661-1442  
FAX: 856-663-6363

#### PITTSBURGH

159 PROMINENCE DRIVE  
NEW KENSINGTON, PA 15068  
PHONE: 724-889-0092  
FAX: 724-889-0094

#### TENNESSEE

**MEMPHIS**  
4000 WINCHESTER ROAD  
MEMPHIS, TN 38118  
PHONE: 901-365-2020  
FAX: 901-365-3914

#### TEXAS

**DALLAS**  
2920 114TH STREET SUITE 100  
GRAND PRAIRIE, TX 75050  
PHONE: 214-634-7271  
FAX: 214-634-8874

#### HOUSTON

10355 W. LITTLE YORK ROAD  
SUITE 300  
HOUSTON, TX 77041  
PHONE: 281-977-6500  
FAX: 281-977-6510

#### UTAH

**SALT LAKE CITY**  
2230 SOUTH MAIN STREET  
SALT LAKE CITY, UT 84115  
PHONE: 801-832-0127  
FAX: 801-832-8911

#### WISCONSIN

**MILWAUKEE**  
1960 SOUTH CALHOUN ROAD  
NEW BERLIN, WI 53151  
PHONE: 262-784-5940  
FAX: 262-784-1215

#### INTERNATIONAL SALES

**FORT SMITH, AR**  
P.O. BOX 2400  
FORT SMITH, AR 72902  
PHONE: 479-646-4711  
FAX: 479-648-5895

#### CANADA

**EDMONTON, ALBERTA**  
4053-92 STREET  
EDMONTON, ALBERTA T6E 6R8  
PHONE: 780-434-4900  
FAX: 780-438-2600

#### TORONTO

**OAKVILLE, ONTARIO**  
2750 COVENTRY ROAD  
OAKVILLE, ONTARIO L6H 6R1  
PHONE: 905-829-3301  
FAX: 905-829-3302

#### MONTREAL, QUEBEC

5155 J-ARMAND BOMBARDIER  
SAINT-HUBERT, QUEBEC  
CANADA J3Z 1G4  
PHONE: 514-933-2711  
FAX: 514-933-8639

#### VANCOUVER,

**BRITISH COLUMBIA**  
1538 KEBET WAY  
PORT COQUILAM,  
BRITISH COLUMBIA V3C 5M5  
PHONE: 604-421-2822  
FAX: 604-421-3113

#### WINNIPEG, MANITOBA

54 PRINCESS STREET  
WINNIPEG, MANITOBA R3B 1K2  
PHONE: 204-942-5205  
FAX: 204-956-4251

#### AUSTRALIA

UNIT 3, 6 STANTON ROAD  
SEVEN HILLS, NSW 2147, AUSTRALIA  
PHONE: (61) (2) 9674 5455  
FAX: (61) (2) 9674 2495

#### UNIT 8, 5 KELLETTS ROAD

ROWVILLE, VICTORIA, 3178  
AUSTRALIA  
PHONE: (61) (3) 9753 4355  
FAX: (61) (3) 9753 4366

#### EL SALVADOR

RESIDENCIAL PINARES DE SUIZA  
POL. 15 #44,  
NVA. SAN SALVADOR, EL SALVADOR  
PHONE: +503 2288-1519  
FAX: +503 2288-1518

#### CHILE

LUIS THAYER OJEDA 166,  
OF 402 - PROVIDENCIA  
SANTIAGO, CHILE  
PHONE: +56 2 964-3210

#### CHINA

160 SONG SHENG ROAD  
SONGJIANG INDUSTRY ZONE  
SHANGHAI 201613, CHINA  
PHONE: +86 21 5760 5335  
FAX: +86 21 5760 5336

#### GERMANY

HERMANN-HEINRICH-GOSSEN-STRASSE 3  
KÖLN, D-50858 GERMANY  
PHONE: +49 2234 37941-0  
FAX: +49 2234 3794164

#### DIESELSTRASSE 22

KIRCHHEIM, D-85551  
MÜNICH, GERMANY  
PHONE: +49 89 90508-0  
FAX: +49 89 9050886

#### INDIA

OFFICE NO 517 & 518,  
5TH FLOOR, SIDDHARTH TOWERS,  
CTS NO. 421 (1), SURVEY NO 12,  
KOTHRUD, PUNE 411 038,  
MAHARASHTRA, INDIA  
PHONE: + 91 20 25 45 27 17  
FAX: + 91 20 25 45 27 19

#### INDONESIA

TALAVEIRA OFFICE PARK,  
28TH FLOOR, SUITE M18  
JI. T.B. SIMATUPANG, KAV. 22-26  
CILANDAK, JAKARTA SELATAN, 12430  
INDONESIA  
PHONE: +62 21 75 999 879  
FAX: + 62 21 75 999 878

#### ITALY

VIA SOTTOBISIO 30  
CH-6828 BALERNA  
SWITZERLAND  
PHONE: +41 91 683 6161  
FAX: +41 91 630 2633

#### JAPAN

DIA BLDG 802,  
2-21-1 TSURUYA-CHO,  
KANAGAWA-KU  
YOKOHAMA, 221-0835, JAPAN  
PHONE: 81-45-412-4506  
FAX: 81-45-412-4507

#### KOREA

RM#1715, SUSEO TOWER, 725,  
SUSEO-DONG, GANGNAM-GU,  
SEOUL 135-757 KOREA  
PHONE: (82) 2 2226 9369  
FAX: (82) 2 2226 9368

#### MEXICO

**LEON, GUANAJUATO**  
KM. 2.0 BLVD. AEROPUERTO  
LEÓN 37545, GUANAJUATO, MÉXICO  
PHONE: +52 477 761 2030  
FAX: +52 477 761 2010

#### MIDDLE EAST & NORTH AFRICA

VSE INTERNATIONAL CORP.  
3233 N ARLINGTON HEIGHTS ROAD  
SUITE 100W  
ARLINGTON HEIGHTS, IL 60004 USA  
PHONE: 847 590 5547  
FAX: 847 590 5587

#### PANAMA

AVE. RICARDO J. ALFARO  
EDIFICIO SUN TOWERS MALL  
PISO 2, LOCAL 55  
CIUDAD DE PANAMÁ, PANAMÁ  
PHONE: +507 236-5155  
FAX: +507 236-0591

#### SINGAPORE

18 KAKI BUKIT ROAD 3, #03-09  
ENTREPRENEUR BUSINESS CENTRE  
SINGAPORE 415978  
PHONE: (65) 6744 2572  
FAX: (65) 6747 1708

#### SWITZERLAND

POST FACH 73  
SCHUETZENSTRASSE 59  
FEUERHALEN, CH-8245  
SWITZERLAND  
PHONE: +41 52 647 4700  
FAX: +41 52 659 2394

#### TAIWAN

1F, NO 126 WENSHAN 3RD STREET,  
NANTUN DISTRICT,  
TAICHUNG CITY 408  
TAIWAN R.O.C  
PHONE: (886) 4 238 04235  
FAX: (886) 4 238 04463

#### UNITED KINGDOM

6 BRISTOL DISTRIBUTION PARK  
HAWKLEY DRIVE  
BRISTOL BS32 0BF U.K.  
PHONE: +44 1454 850000  
FAX: +44 1454 859001

#### VENEZUELA

AV. ROMA. QTA EL MILAGRO. URB.  
CALIFORNIA NORTE  
CARACAS, 1070  
VENEZUELA  
PHONE/FAX: +58 212 272 7343  
MOBILE: +58 414 114 8623

Baldor Electric Company  
P.O. Box 2400  
Fort Smith, AR 72902-2400 U.S.A  
Ph (479) 646-4711 • Fax (479) 648-5792  
International Fax (479) 648-5895  
[www.baldor.com](http://www.baldor.com)