

## ControlMaster CM30 and CM50 Universal process controllers, 1/4 and 1/2 DIN



## The Company

We are an established world force in the design and manufacture of instrumentation for industrial process control, flow measurement, gas and liquid analysis and environmental applications.

As a part of ABB, a world leader in process automation technology, we offer customers application expertise, service and support worldwide.

We are committed to teamwork, high quality manufacturing, advanced technology and unrivalled service and support.

The quality, accuracy and performance of the Company's products result from over 100 years experience, combined with a continuous program of innovative design and development to incorporate the latest technology.

**Basic Level**

Refer to Section 6, page 18

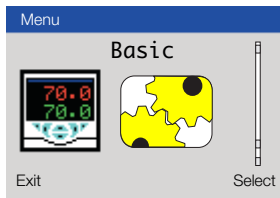

- Loop 1 (2) Setpoints
  - Local Setpoint 1 (4)
  - RSP Ratio
  - RSP Bias
  - Ramp Mode
  - Ramp Rate
- Loop 1 (2) Control
  - On/Off Mode
  - Autotune
  - PID
  - FeedForward
- Loop 1 (2) Mot Valve
  - Ratio
  - Bias
  - Deadband
  - Travel Time
- Loop 1 (2) Time Prop
  - Cycle Time 1 (2)
- Alarm 1 (8)
  - Trip

**\*Advanced Level...**

Refer to Section 7.1, page 24

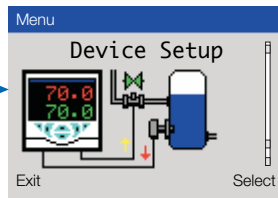

- Initial Setup
  - App. Template
  - Loop 1 (2) Output Type
  - Loop 1 (2) Split O/P
  - Instrument Tag
  - Loop 1 (2) Tag
  - Mains Freq.
  - Config Action
  - Custom Template
  - Reset to Defaults
- Security Setup
  - Basic Password
  - Advanced Password
  - Reset Passwords
- Custom Config
  - Off
  - Loop 1 (2) PV
  - Loop 1 (2) Split O/P
  - Loop 1 (2) Valve O/P
  - Loop 1 (2) Valve FB
  - Loop 1 (2) TP OP1 (2)
  - Loop 1 (2) RSP

Refer to Section 7.2, page 26

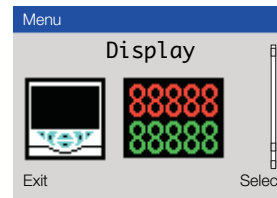

- Language
- Operator Templates
  - Page 1 Template
- Operator Functions
  - Autoscroll
  - Soft Key Function
  - Auto Manual Enable
  - Local Remote Enable
  - Alarm Ack. Enable
  - Totalizer Stop/Go
  - Totalizer Reset
  - SP Adjust Enable
- Chart View
  - Channel 1
  - Sample Rate
- Settings
  - Brightness
  - Contrast\*\*
- Date & Time
  - Date Format
  - Time & Date
  - Daylight Saving
  - DS Start Time
  - DS Start Occur
  - DS End Occur
  - DS Start Day
  - DS End Day
  - DS Start Month
  - DS End Month
- Customise Pages
  - Page Number
  - Template Type
  - Titlebar Tag
  - Parameters
  - Bargraphs
  - Icons
  - Page Colors

Refer to Section 7.3, page 32

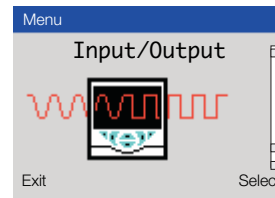

- Analog Inputs
  - Anlg Input 1 (4)
- Analog Outputs
  - Analog Output 1 (2)
- Digital I/O
  - Digital IO 1 (6)
- Relays
  - Relay 1 (4)

Refer to Section 7.4, page 36

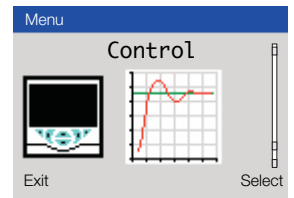

- Loop 1 (2) Setpoints
  - Low Limit
  - High Limit
  - No. of Local SP's
  - Local Setpoint 1 (4)
  - Track Mode
  - RSP Ratio
  - RSP Bias
  - RSP Fault Action
  - Default Setpoint
  - Ramp Mode
  - Ramp Rate
  - Select Sources
- Loop 1 (2) Output Limits
  - Failure Actions
  - A/M Select Sources
  - Slew Rate
  - Tracking
- Loop 1 (2) Split O/P
  - Min Input 1 (2)
  - Min OP 1 (2)
  - Max Input 1 (2)
  - Max OP 1 (2)
- Loop 1 (2) Valve Ratio
  - Bias
  - Deadband
  - Travel time
- Loop 1 (2) Time Prop
  - Cycle Time 1 (2)
- Loop 1 (2) Control
  - Control Type
  - Control Action
  - On/Off Hysteresis
  - Autotune
  - Gain Scheduling
  - FeedForward
  - Adaptive Control
  - Misc.

Refer to Section 7.5, page 47

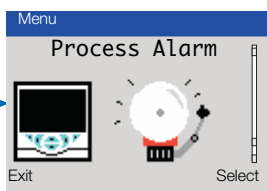

- Alarm 1 (8)
  - Type
  - Tag
  - Source
  - Count Direction
  - Units
  - Count Rate
  - Cutoff
  - Stop Go Source
  - Total DPs
  - Preset Count
  - Predet Count
  - Intermed'te Count
  - Wrap Enable
  - Reset Source
  - Reset Days
  - Reset Hour
- Acknowledge Source
- Enable Source

Refer to Section 7.6, page 49

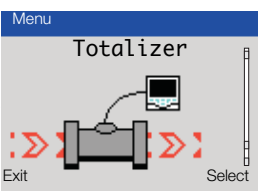

- Totalizer 1 (2)
  - Mode
  - Source
  - Count Direction
  - Units
  - Count Rate
  - Cutoff
  - Stop Go Source
  - Total DPs
  - Preset Count
  - Predet Count
  - Intermed'te Count
  - Wrap Enable
  - Reset Source
  - Reset Days
  - Reset Hour

Refer to Section 7.7, page 53

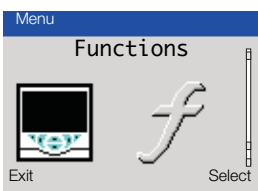

- Logic Equations
  - Equation Number
  - Operand 1
  - Invert 1
  - Operator 1
- Math Blocks
  - Math Block Number
  - Block Type
  - Eng. DPs
  - Eng. Low
  - Eng. High
  - Eng. Units
  - Fault Action
- Linearizer 1 (2)
- Delay Timer 1 (2)
  - Source
  - Delay Time
  - On Time
- Real Time Alarms
  - Real Time Alarm 1 (2)
  - Monday (to Sunday)

Refer to Section 7.8, page 58

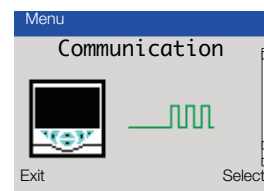

- Refer to IM/CM/C-EN for parameter details.

Refer to Section 7.9, page 59

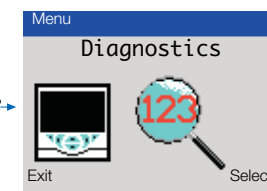

- Diagnostic History
- Source Analysis
  - Analog Source
  - Digital Source
  - Invalid Sources

Refer to Section 7.10, page 63



- Instrument Type
- I/O Build
- No. Analog Inputs
- No. Analog Outputs
- No. Relays
- No. Digital I/O
- Functionality
- Serial No.
- Hardware Revision
- Software Revision

\*When in *Advanced Level* (configuration mode), press and hold the key to return to the standard *Operator* page – see Fig. 3.1, page 5.

\*\*Enabled for CM30 and CM50 only

# Contents

<b>1</b>	<b>Safety</b>	<b>3</b>
1.1	Electrical Safety	3
1.2	Symbols	3
1.3	Health & Safety	3
<b>2</b>	<b>Introduction</b>	<b>4</b>
2.1	EC Directive 89/336/EEC	4
2.2	End of Life Disposal	4
<b>3</b>	<b>Display Overview</b>	<b>5</b>
3.1	Front Panel Keys	6
<b>4</b>	<b>Installation</b>	<b>7</b>
4.1	Siting	7
4.2	Dimensions	8
4.3	Mounting	9
4.4	Jumper Links for Relay Outputs	9
4.4.1	Removing the Controller from its Case	9
4.4.2	Resetting Jumper Links	10
4.5	Electrical Connections	11
4.5.1	CM30 Electrical Connections	12
4.5.2	CM50 Electrical Connections	13
4.5.3	Analog Inputs	14
4.5.4	Frequency / Pulse Input	15
4.5.5	Digital Input / Output	15
<b>5</b>	<b>Operator Level Menus</b>	<b>16</b>
5.1	Diagnostic Status Bar	16
5.2	Diagnostic View	17
5.3	Security Options	17
5.4	Access Level	17
<b>6</b>	<b>Basic Level</b>	<b>18</b>
<b>7</b>	<b>Advanced Level</b>	<b>24</b>
7.1	Device Setup	24
7.2	Display	26
7.3	Input/Output	32
7.4	Control	36
7.5	Process Alarm	47
7.6	Totalizer	49
7.6.1	Calculating the Totalizer Count Rate Manually	51
7.7	Functions	53
7.8	Communication	58
7.9	Diagnostics	59
7.9.1	Diagnostic Messages	60
7.10	Device Info	63

---

<b>8</b>	<b>Templates and Functionality</b>	<b>64</b>
8.1	Basic Templates	64
8.1.1	Single Loop / Single Loop with Remote Setpoint	64
8.2	Standard Templates	65
8.2.1	Auto / Manual Station (Low Signal Selection / Digital Signal Selection)	65
8.2.2	Analog Backup Station (Low Signal Selection / Digital Signal Selection)	66
8.2.3	Single Indicator	67
8.2.4	Dual Indicator	67
8.3	Extended Templates	68
8.3.1	Feedforward / Feedforward with Remote Setpoints	68
8.3.2	Cascade / Cascade with Remote Setpoints	68
8.3.3	Cascade with Feedforward	69
8.3.4	Ratio Controller (Internal / External Ratio)	69
8.3.5	Ratio Station (Internal / External Ratio)	70
8.4	Dual Loop Templates	71
8.4.1	Dual Loop – Local Setpoint / Local Setpoint	71
8.4.2	Dual Loop – Remote Setpoint / Local Setpoint	71
8.4.3	Dual Loop – Remote Setpoint / Remote Setpoint	71
<b>9</b>	<b>PC Configuration</b>	<b>72</b>
<b>10</b>	<b>Specification</b>	<b>73</b>
<b>Appendix A</b>	<b>Digital and Analog Sources</b>	<b>79</b>
A.1	Digital Sources	79
A.2	Analog Sources	80
<b>Appendix B</b>	<b>Configuration Error Codes</b>	<b>81</b>
<b>Appendix C</b>	<b>Analog Input Engineering Units</b>	<b>83</b>
<b>Appendix D</b>	<b>Output Type Assignments</b>	<b>84</b>

# 1 Safety

Information in this manual is intended only to assist our customers in the efficient operation of our equipment. Use of this manual for any other purpose is specifically prohibited and its contents are not to be reproduced in full or part without prior approval of the Technical Publications Department.





## 1.1 Electrical Safety





This equipment complies with the requirements of CEI/IEC 61010-1:2001-2 'Safety Requirements for Electrical Equipment for Measurement, Control and Laboratory Use' and complies with US NEC 500, NIST and OSHA.

If the equipment is used in a manner NOT specified by the Company, the protection provided by the equipment may be impaired.

## 1.2 Symbols

One or more of the following symbols may appear on the equipment labelling:

	<b>Warning</b> – Refer to the manual for instructions
	<b>Caution</b> – Risk of electric shock
	Functional earth (ground) terminal
	Protective earth (ground) terminal

	Direct current supply only
	Alternating current supply only
	Both direct and alternating current supply
	The equipment is protected through double insulation

## 1.3 Health & Safety

### Health and Safety

To ensure that our products are safe and without risk to health, the following points must be noted:

- The relevant sections of these instructions must be read carefully before proceeding.
- Warning labels on containers and packages must be observed.
- Installation, operation, maintenance and servicing must be carried out only by suitably trained personnel and in accordance with the information given.
- Normal safety precautions must be taken to avoid the possibility of an accident occurring when operating in conditions of high pressure and / or temperature.

Safety advice concerning the use of the equipment described in this manual or any relevant hazard data sheets (where applicable) may be obtained from the Company, together with servicing and spares information.

## 2 Introduction

This manual provides details for the ControlMaster CM30 (1/4 DIN) and CM50 (1/2 DIN) controllers with Extended / Dual Loop functionality

**Note.**

- Read all relevant sections of this guide before configuring the system or modifying system parameters.
- Install and use associated equipment in accordance with the relevant national and local standards.
- System configuration must be carried out only by users or personnel with approved access rights (user privileges).

### 2.1 EC Directive 89/336/EEC

In order to meet the requirements of the EC Directive 89/336/EEC for EMC regulations, this product must not be used in a non-industrial environment.

### 2.2 End of Life Disposal

Controllers with Standard functionality and above contain a small lithium battery that must be removed and disposed of responsibly in accordance with local environmental regulations.

### 3 Display Overview

The ControlMaster display and icons are shown in Fig. 3.1:

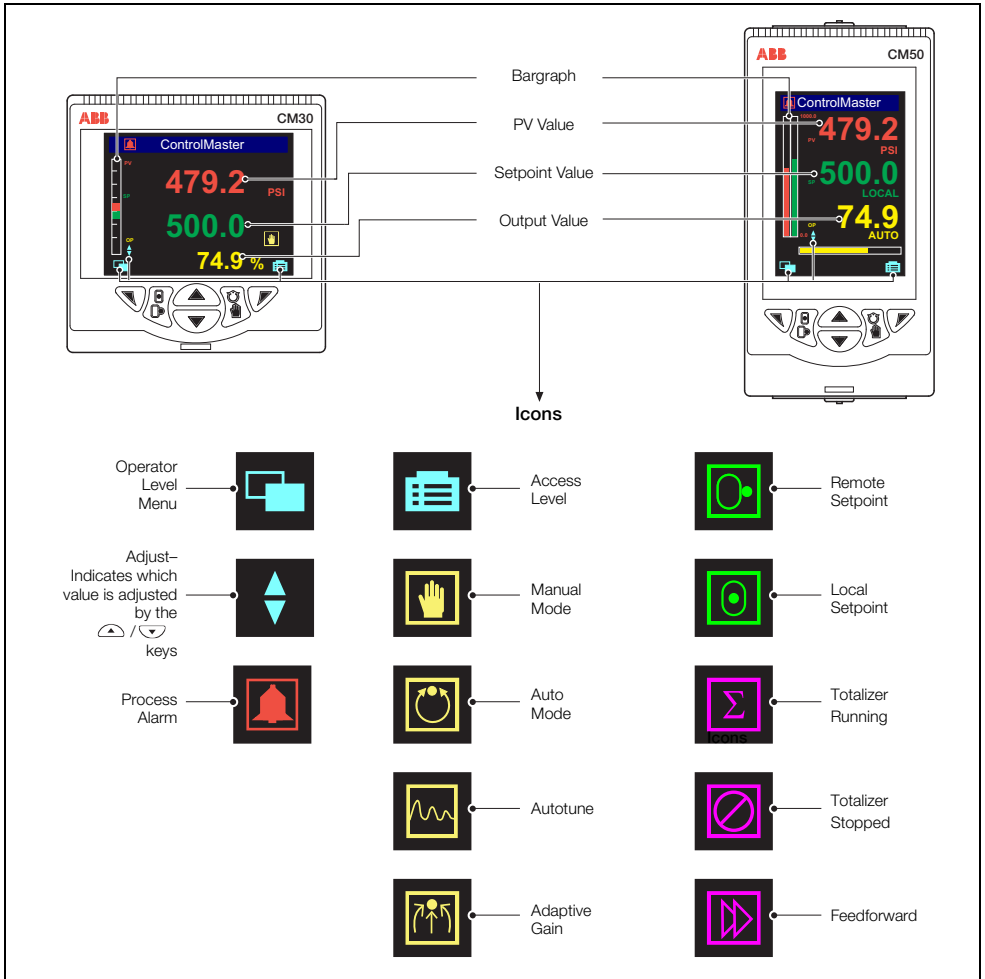

Fig. 3.1 ControlMaster CM30 and CM50 Displays and Icons

### 3.1 Front Panel Keys

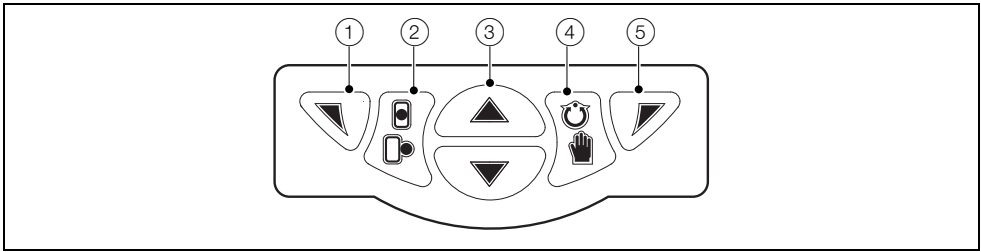

Fig. 3.2 Front Panel Keys

- 1 Navigation (left) / *Operator Level* access key – see page 16.
- 2 Local / Remote setpoint mode selection key.
- 3 Up / Down keys – navigate up / down menus and increase / decrease displayed values.
- 4 Auto / Manual control mode selection key.
- 5 Navigation key (right) / programmable Soft Key – see page 27.

**Note.** When a Soft Key option is assigned to key (5), the *Advanced Level* (see page 24) must be accessed using the *Operator Level* access key (1).



## 4 Installation

**Caution.** Select a location away from strong electrical and magnetic fields. If these cannot be avoided, particularly in applications where 'walkie talkies' are used, connect using screened cables within grounded metal conduit

### 4.1 Siting

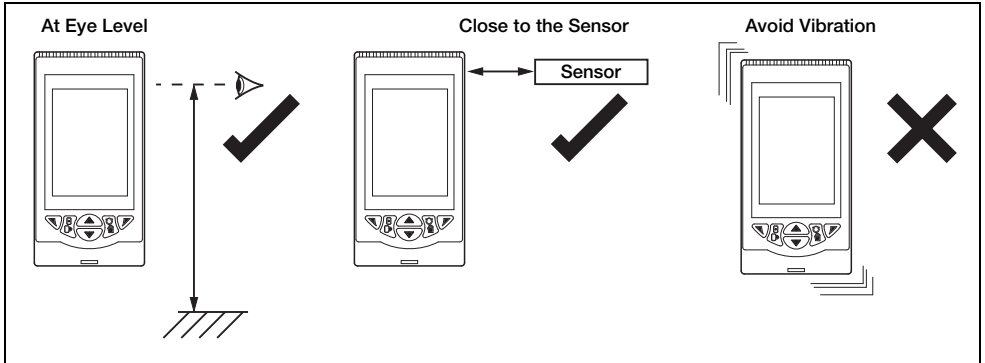

Fig. 4.1 Siting

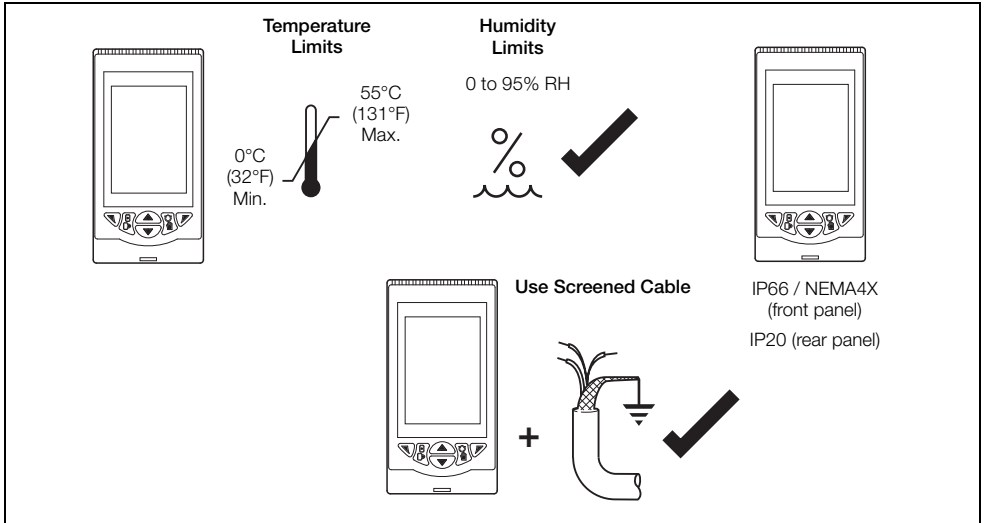

Fig. 4.2 Environmental Requirements

## 4.2 Dimensions

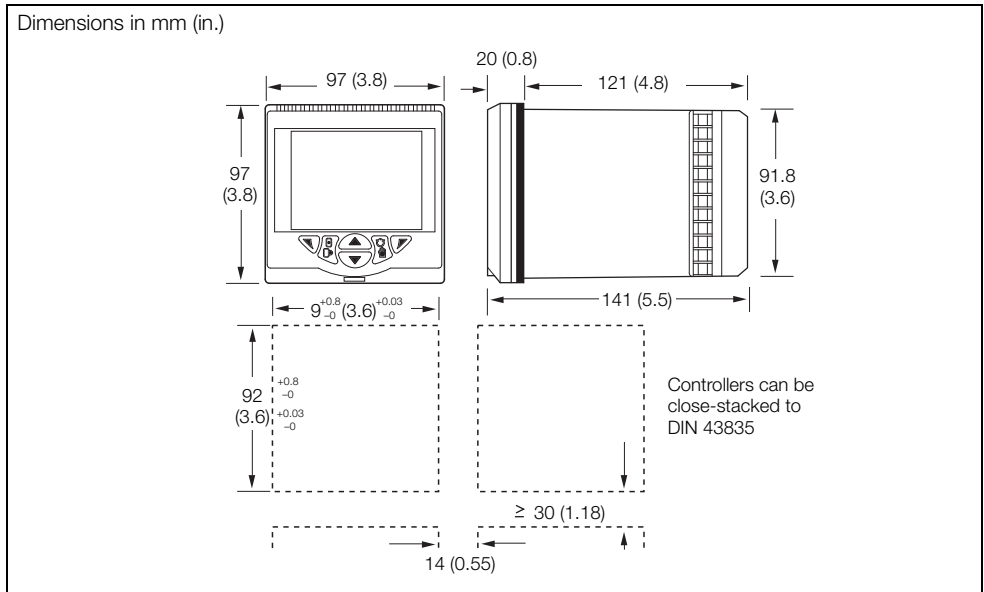

Fig. 4.3 ControlMaster CM30 Dimensions

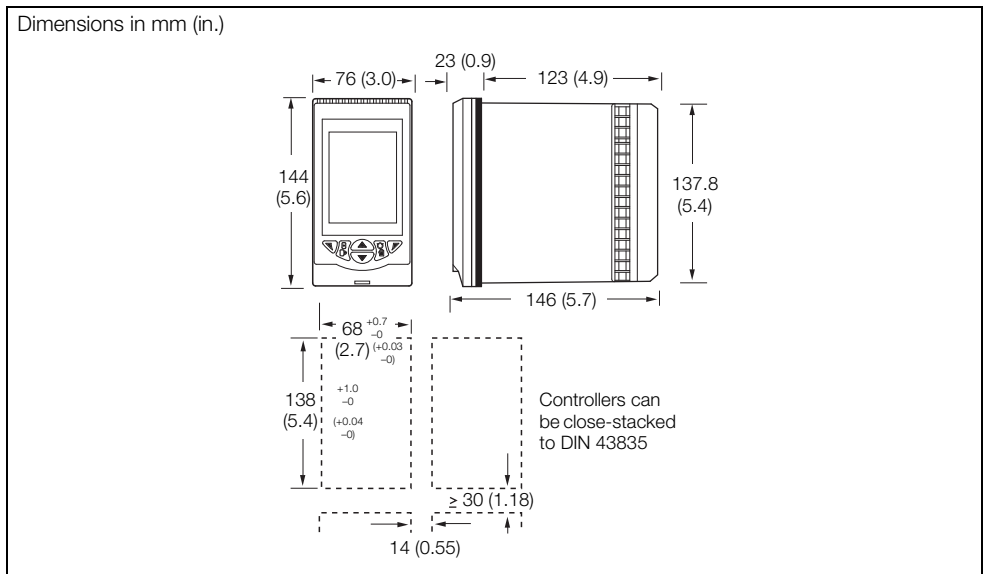

Fig. 4.4 ControlMaster CM50 Dimensions

### 4.3 Mounting

ControlMaster is designed for panel mounting. For NEMA4X protection, a panel thickness of 2.5 mm (0.1 in.) is required.

To panel-mount the controller:

1. Cut a hole of the correct size for the controller in the panel (see page 8 for dimensions).
2. Insert the controller into the panel cut-out.  
Referring to Fig. 4.5:
3. Position the upper panel clamp (A) at the top front of the case against the panel.
4. Locate the panel clamp anchor (B) in slot (C).
5. Tighten the panel clamp anchor screw (D) until panel clamp (A) is secured against the panel.

**Note.** Do not overtighten the screw.

6. Repeat steps 3 to 5 to fit the lower panel clamp (E) and panel clamp anchor (F).

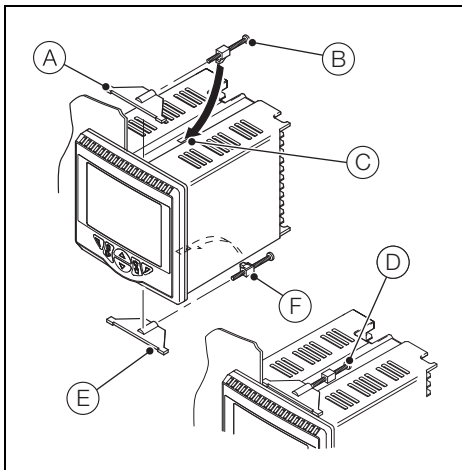

Fig. 4.5 Mounting Details

### 4.4 Jumper Links for Relay Outputs

The factory-set default for relay action is N/O.

#### 4.4.1 Removing the Controller from its Case

The ControlMaster inner assembly must be removed from its case to access the relay contact jumper links.

Referring to Fig. 4.6:

1. Insert the bezel release tool (A) into the front panel slot (B) below the function keys.
2. Press the bezel release tool (A) fully in and then down (C) until the shoulder on the tool engages with the notch behind the controller front plate.
3. Pull the bezel release tool (A) to withdraw the inner assembly from the case (D).

**Note.** If the bezel release tool is mislaid, 2 small flat-headed screwdrivers (4 mm [0.15 in.]) can be used as alternative tools, one inserted into the front panel slot and the second for leverage in the notch on the underside of the controller front plate. The notch is the only area that can be used as a leverage point – do not attempt to lever the front panel from any other area.

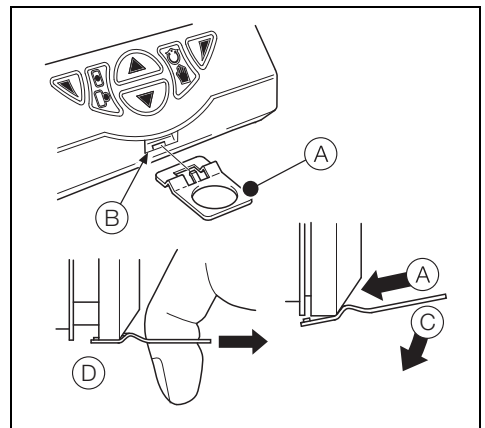

Fig. 4.6 Removing the Controller from its Case

### 4.4.2 Resetting Jumper Links

**Note.** The factory-set default for all jumper links is N/O.

1. The links associated with the relay outputs are shown in Fig. 4.7.
2. If necessary, move the link to select the relay action required (N/O or N/C).

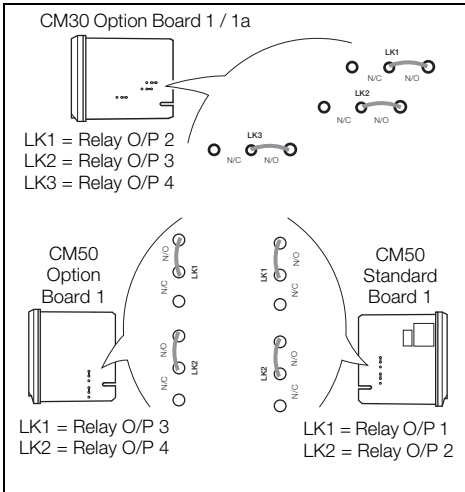

Fig. 4.7 Jumper Links for Relay Outputs

## 4.5 Electrical Connections

### **Warning.**

- The controller is not fitted with a switch therefore a disconnecting device such as a switch or circuit breaker conforming to local safety standards must be fitted to the final installation.
- The switch must be mounted in close proximity to the controller within easy reach of the operator and must be marked clearly as the disconnection device for the controller.
- Remove all power from supply, relay and any powered control circuits and high common mode voltages before accessing or making any connections.
- Use cable appropriate for the load currents. The terminals accept cables from 18 to 14 AWG (0.8 to 2.5mm<sup>2</sup>).
- Always route signal leads and power cables separately, preferably in earthed (grounded) metal conduit.
- It is strongly recommended that screened cable is used for signal inputs and relay connections.
- The instrument conforms to Mains Power Input Overvoltage Category 2, Pollution Degree 2 (EN601010-1). (This equipment is protected through double insulation – Class II.)
- Analog / digital inputs and outputs, transmitter power supply and DC power supply are SELV (Safety Extra Low Voltage) circuits.
- All connections to secondary circuits must have basic insulation.
- After installation, there must be no access to live parts, for example terminals.
- Terminals for external circuits are for use with equipment with no accessible live parts only.
- If the controller is used in a manner not specified by the Company, the protection provided by the equipment may be impaired.
- All equipment connected to the controller's terminals must comply with local safety standards (IEC 60950, EN601010-1).

**Note.** Terminal screws must be tightened to a torque of 0.1 Nm (0.9 lbf/in.).

### 4.5.1 CM30 Electrical Connections

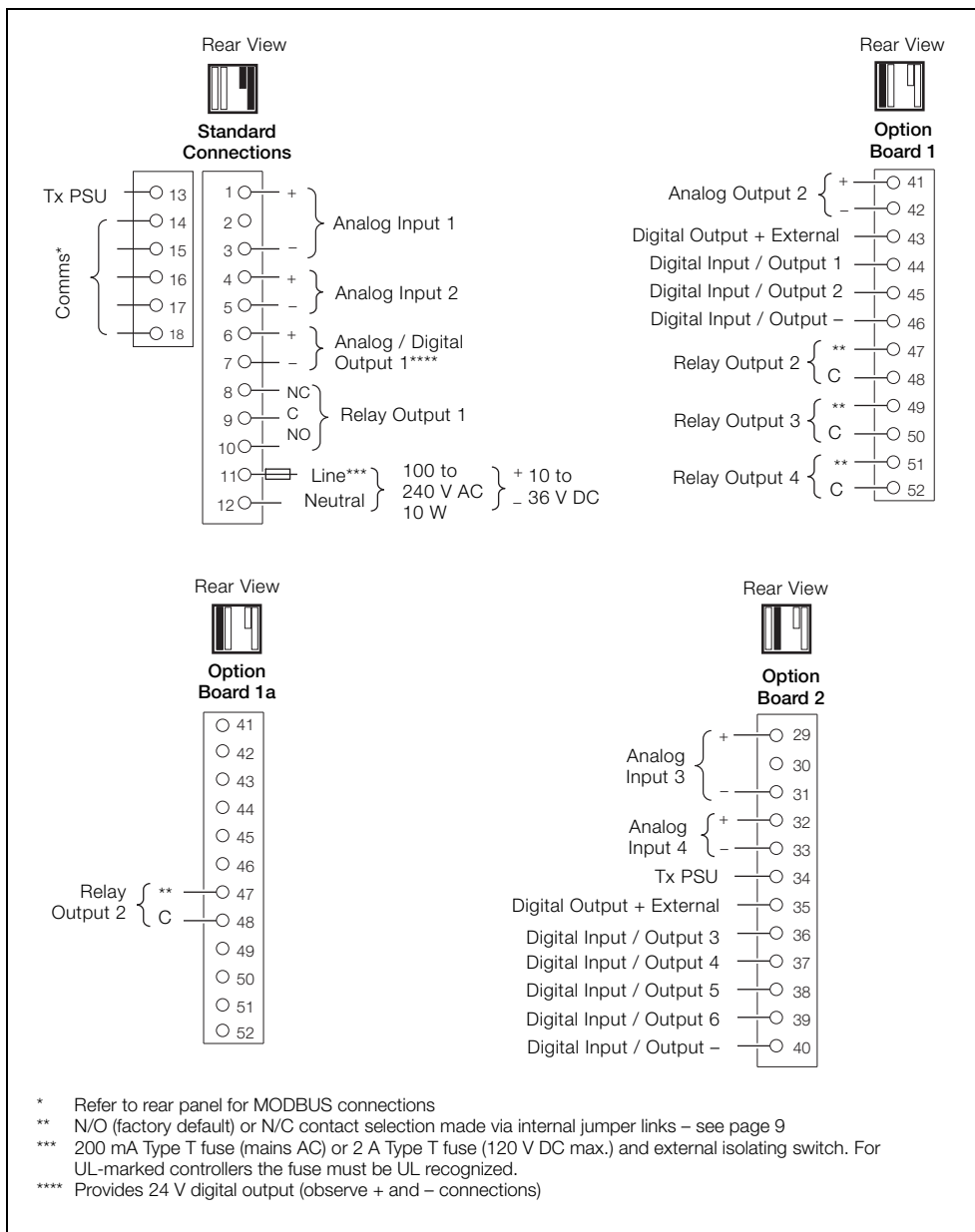

Fig. 4.8 CM30 Electrical Connections

**4.5.2 CM50 Electrical Connections**

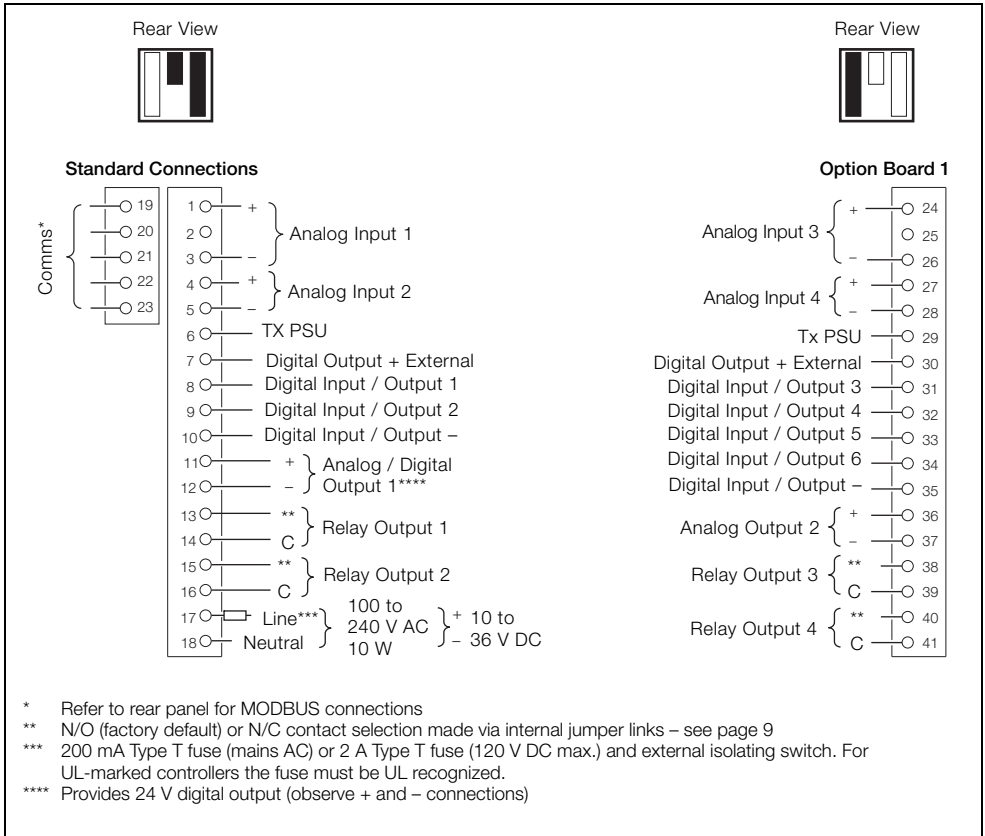

Fig. 4.9 CM50 Electrical Connections

### 4.5.3 Analog Inputs

**Note.** Standard terminal connections for inputs 1 and 2 are shown in Fig. 4.10. Optional analog inputs 3 and 4 are shown in Fig. 4.11.

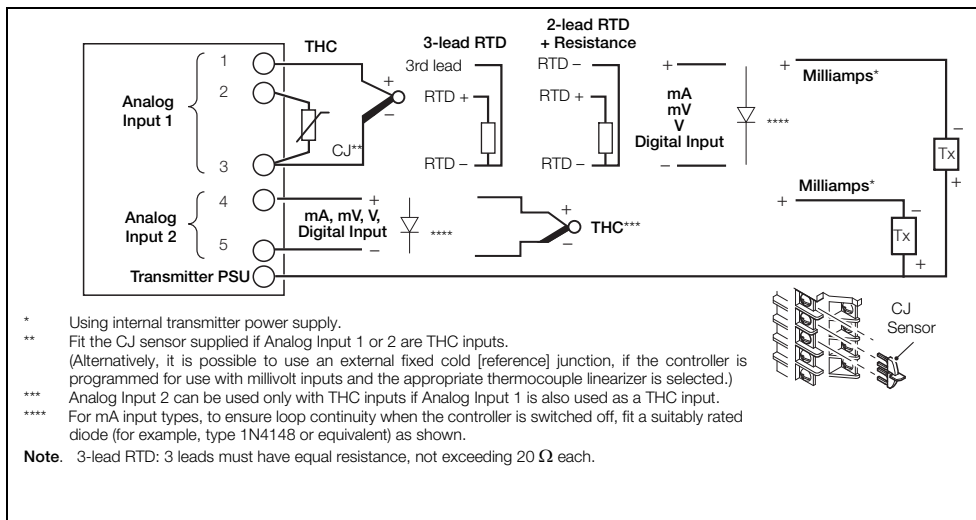

Fig. 4.10 Standard Analog Inputs (1 and 2)

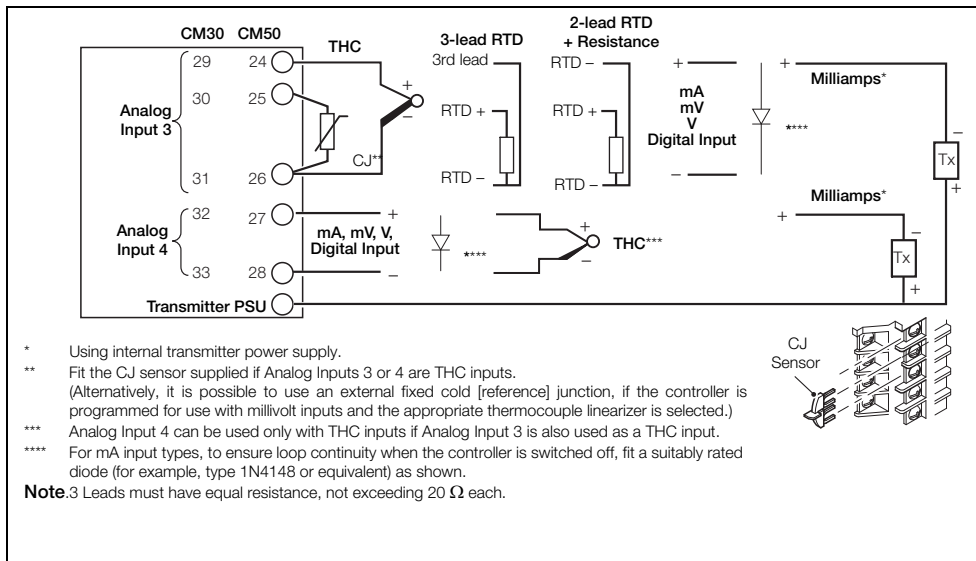

Fig. 4.11 ControlMaster CM30 and CM50 Optional Analog Inputs (3 and 4)



### 4.5.4 Frequency / Pulse Input

**Note.** This input is designed primarily for use with flowmeters.

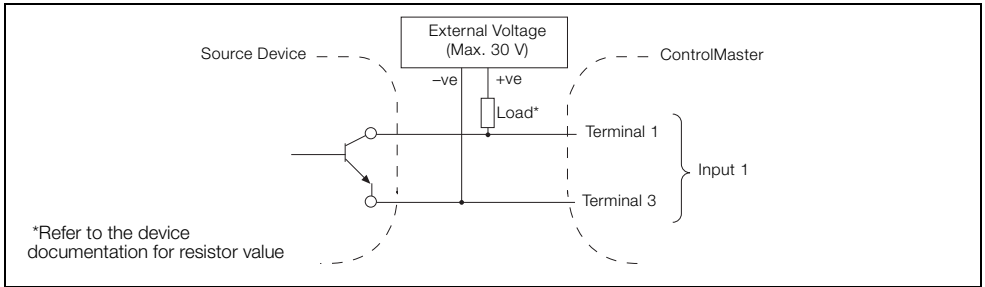

Fig. 4.12 Frequency / Pulse Input

### 4.5.5 Digital Input / Output

**Note.** Digital input and open collector digital output connections are shown in Fig. 4.13 – see page 77 for Digital Input / Output type options.

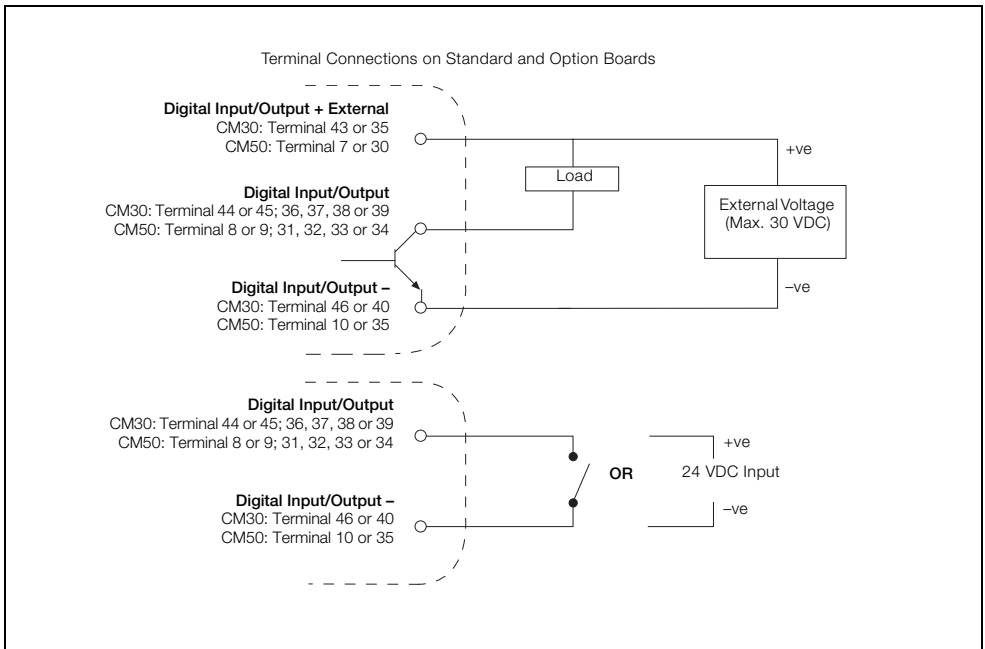
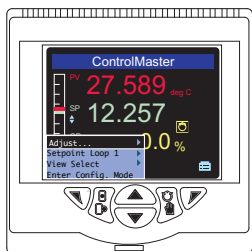

Fig. 4.13 Digital Input and Open Collector Digital Output Connections

## 5 Operator Level Menus



Operator level menus are used to adjust setpoint(s) and output(s), select setpoints, select the view and to enter *Basic* and *Advanced* modes (via the *Access* level).

To access Operator Level menus:

1. From the *Operator Page*, press to view the available menus.
2. Use the / keys to scroll through the menus and menu options.
3. Press to expand menu levels and to select menu options or press to return to the previous menu.

Menu functions are described in Table 5.1.

<b>Autotune</b>	Used to start or stop an autotune routine. This menu is enabled only if <i>Autotune</i> mode is <i>On</i> .
<b>Adjust</b>	Enables a value to be adjusted using the  /  keys. The  icon next to a value indicates the current adjustable selection.
<b>Setpoint Select</b>	Selects the local setpoint to be used (displayed only if more than 1 local setpoint is configured).
<b>Alarm Acknowledge</b>	Acknowledges any active but unacknowledged alarms.
<b>View Select</b>	Selects the <i>Operator</i> view to be displayed.
<b>Enter Config. Level</b>	Displays the <i>Access Level</i> selection views – see Section 5.4, page 17 for security options.

Table 5.1 Operator Level Menu Functions

### 5.1 Diagnostic Status Bar

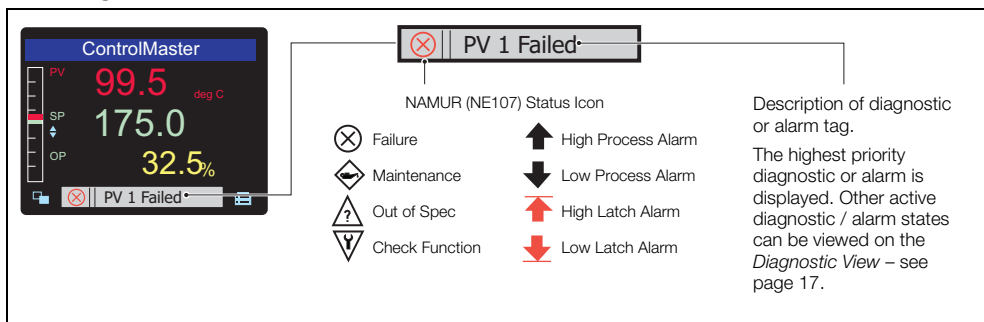

Fig. 5.1 ControlMaster Diagnostic Status Bar (ControlMaster CM30 Shown)

## 5.2 Diagnostic View

The *Diagnostic View* can be selected from the *Operator / View Select* menu. All currently active diagnostic alarm states are displayed in the *Diagnostic View*.

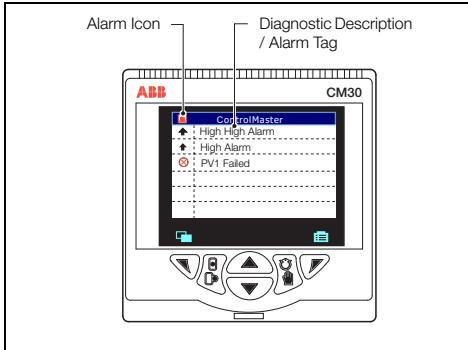

Fig. 5.2 ControlMaster Diagnostic View (ControlMaster CM30 Shown)

## 5.3 Security Options

Passwords can be set to enable secure end-user access at 2 levels: *Basic* and *Advanced*. The *Service* level is password protected at the factory and reserved for factory use only.

Passwords are set, changed or restored to their default settings at the *Device Setup / Security Setup* parameter – see page 25.

**Note.** When the controller is powered-up for the first time the *Basic* and *Advanced* level levels can be accessed without password protection. Protected access to these levels must be allocated on-site as required.

## 5.4 Access Level

Level	Access
Logout	Displayed after <i>Basic</i> or <i>Advanced</i> level are accessed. Logs the user out of <i>Basic</i> or <i>Advanced</i> level. If passwords are set, a password must be entered to access these levels again after selecting <i>Logout</i> .
Read Only	Enables all parameter settings to be viewed
Basic	Enables access to the <i>Basic</i> level and adjustment of <i>PID</i> parameters (see page 20), enabling autotuning configuration and adjustment of alarm trip points.
Advanced	Enables configuration access to all parameters.
Service	Reserved for use by authorized service personnel.

Table 5.2 Access Levels

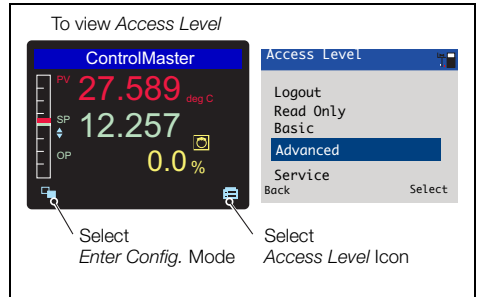
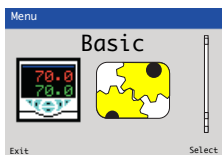

Fig. 5.3 Access Level

**Note.** A 5-minute time-out period enables a user to return to the *Operator* page and re-access the previous menu (displayed at exit) without re-entering the password. For periods over 5-minutes (or if *Logout* is selected), a password must be re-entered to access protected levels.

## 6 Basic Level



The *Basic* menu provides access to the tunable control settings and setpoint values.

### Loop 1 (2) Setpoints

**Local Setpoint 1 (4)** The local setpoint value required. If this value is adjusted in the *Operator Level* (see page 16) its value in here is also updated.

**RSP Ratio** If the remote (external) setpoint is selected the control setpoint value is (ratio x remote setpoint input) + bias.

**Note.** This parameter is available only if the template selected has remote setpoint or if a ratio controller / station template is selected – see page 69.

**RSP Bias** Sets the remote setpoint bias in engineering units.

**Note.** This parameter is available only if template selected has remote setpoint or ratio.

**Ramp Mode** The ramping setpoint facility can be used to prevent a large disturbance to the control output when the setpoint value is changed. The rate set applies to both the local and the remote setpoints.

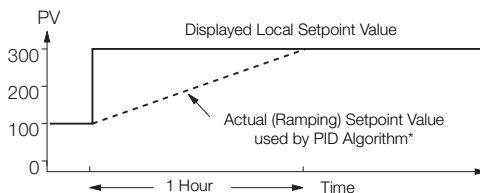

\*Example: Ramp Rate = 200 Increments / Hour

**Ramp Rate** Sets the ramp rate required in engineering units / hour.

**Note.** Applicable only if *Ramp Mode* is *On*.

...Basic

**Loop 1 (2) Control**

**On/Off Hysteresis**

Sets the hysteresis value in engineering units.

**Note.** Applicable only if *Control Type* is *On/Off* – see page 39.

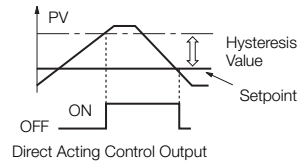
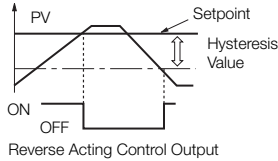

**Mode**

Turns the *Autotune* functionality on or off. When set to *On*, an *Autotune* can be started from the *Operator* level menus – see page 16.

**Autotune**

*Autotune* is a user-activated feature that enables automatic setting of the controller *PID* parameters (see page 20) using an 'at setpoint type' algorithm. *Autotune* changes the controller output and then monitors the process response to calculate the optimum *PID* settings. *Autotune* uses a relay-type function with hysteresis that initiates a controlled oscillation in the process. New *PID* parameters are calculated and stored in the controller automatically.

**Note.** To achieve the best results from *Autotune*, switch the controller to *Manual* control mode (see page 6) and adjust the output until the PV is stable (close to the normal setpoint) before initiating *Autotune*.

**Autotune Operation**

The *Autotune* sequence is shown in the following figure:

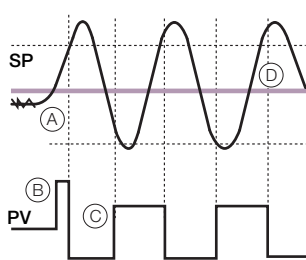

- ① Set the first step value and dynamics required. For best results, select the largest initial output step size that can be tolerated by the process.
- ② *Autotune* is enabled only if the control type is *PID*.
- ③ Start *Autotune* from the *Operator* menu.
- ④ Monitors a noise (A) and calculates a hysteresis value?
- ⑤ User-defined initial step in the output (B). When the process exceeds the hysteresis value the output is stepped down.
- ⑥ Adjusts output amplitude automatically (C) so PV disturbance is kept to minimum required.
- ⑦ When consistent oscillation is established (D), the *Autotune* process stops. Optimum settings are calculated from the process dynamics monitored.

...Basic / ...Loop 1 (2) Control / ... Autotune

<b>First Step</b>	Defines the maximum size of the first output step in the autotuning process. <i>Autotune</i> adjusts the output step magnitude according to the process noise and response to provide a reliable measurement of the process characteristics with the minimum disturbance of the process. The maximum setting provides the largest output step possible from the current output value.																								
<b>Dynamics</b>	Used to configure <i>Autotune</i> to give optimum results according to the type of process being controlled.																								
<i>Normal</i>	Determines if derivative control is required automatically and calculates the control settings accordingly.																								
<i>Deadtime</i>	Sets the proportional and integral terms to give optimum control for the deadtime process (higher proportional band [lower gain] and shorter integration time).																								
<i>PI</i>	Used for processes where it is known that derivative control is not required.																								
<b>Reset</b>	If the controller is transferred to another process or duty, <i>Autotune</i> must be reset. The current <i>PID</i> (see below) settings are retained but the internal process data is cleared ready for a completely new process with different characteristics.																								
<b>PID</b>	The controller's <i>PID</i> settings can be commissioned using the <i>Autotune</i> (see page 19) function and / or they can be adjusted manually. 3 Sets of parameters are provided to facilitate <i>Gain Scheduling</i> control – see page 40. When <i>Gain Scheduling</i> is not enabled, the first set of <i>PID</i> parameters only are used.																								
<i>Proportional Band 1</i>	Set as % of engineering range.																								
<i>Integral Time 1</i>	Set in seconds per repeat. To turn integral action off, set to 0 or 10000 s.																								
<i>Derivative Time 1</i>	Set in seconds.																								
<i>Manual Reset</i>	When the <i>Integral Time</i> is <i>Off</i> , the manual reset parameter is activated. When the process variable is equal to the control setpoint, the output value is equal to the manual reset value.  <b>Note:</b> The controller is shipped with null <i>PID</i> values (P=100, I=off & D=0). To enable the controller to control the process it is connected to, these values must be tuned accordingly. This can be achieved via the AutoTune function or manual adjustment. If the controller is tuned manually the table below provides details of some suggested values to start from.  These values are only suggested starting values and should not be used as an alternative to proper tuning of the Controller.																								
	<table border="1"> <thead> <tr> <th>Process Type</th> <th>P</th> <th>I</th> </tr> </thead> <tbody> <tr> <td>Temperature (fast)*</td> <td>10</td> <td>30</td> </tr> <tr> <td>Temperature (slow)*</td> <td>10</td> <td>300</td> </tr> <tr> <td>Pressure (fast)</td> <td>100</td> <td>1</td> </tr> <tr> <td>Pressure (slow)</td> <td>10</td> <td>30</td> </tr> <tr> <td>Level (fast)</td> <td>100</td> <td>1</td> </tr> <tr> <td>Level (slow)</td> <td>10</td> <td>30</td> </tr> <tr> <td>Flow</td> <td>100</td> <td>1</td> </tr> </tbody> </table>	Process Type	P	I	Temperature (fast)*	10	30	Temperature (slow)*	10	300	Pressure (fast)	100	1	Pressure (slow)	10	30	Level (fast)	100	1	Level (slow)	10	30	Flow	100	1
Process Type	P	I																							
Temperature (fast)*	10	30																							
Temperature (slow)*	10	300																							
Pressure (fast)	100	1																							
Pressure (slow)	10	30																							
Level (fast)	100	1																							
Level (slow)	10	30																							
Flow	100	1																							
	*For temperature loops, control performance can be improved via the use of Derivative. A suggested starting value is 1/6 <sup>th</sup> of the Integral value.																								
<b>FeedForward</b>	Applicable only if a <i>FeedForward</i> application template is enabled – see Section 8, page 64 for template details.																								
<b>Gain</b>	Sets the gain to be used when in <i>Static Gain</i> mode – see page 42.  In <i>Adaptive Gain</i> mode this value is set automatically by the controller – see page 42.																								

...Basic

**Loop 1 (2) Mot Valve**

**Motorized Valve Output With Feedback**

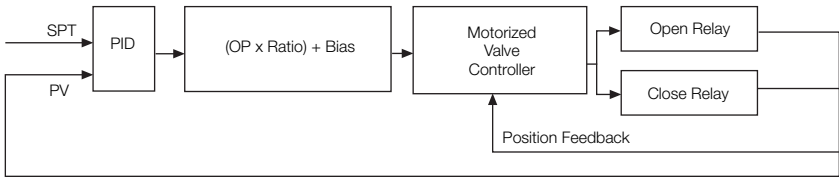

**Motorized Valve Output Without Feedback (Boundless)**

A motorized valve output without feedback (boundless) process controller provides an output that is effectively the time derivative of the required regulator position (the controller signals the regulator, not where to go to [position derivative], but in the direction to travel and how far to move) by a series of integral action pulses. Therefore, the controller does not need to know the absolute regulator position and is not affected when the regulator reaches the upper or lower limit, as determined by the regulator's limit switches (hence the term 'boundless').

When a deviation from setpoint is introduced, the regulator is driven for a length of time equivalent to the proportional step. The regulator is then driven by integral action pulses until the deviation is within the deadband setting.

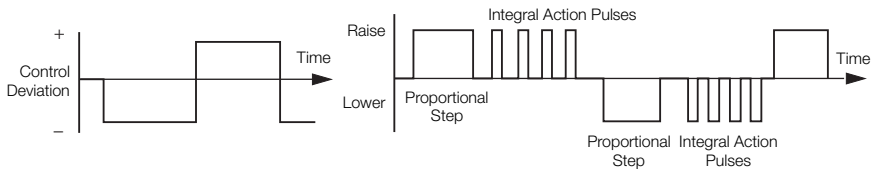

...Basic / ...Loop 1 (2) Mot Valve

**Calculation for Control Pulses (Boundless Control)**

The following calculations are for guidance when setting Deadband, proportional and integral values.

The Deadband on the ControlMaster is set in engineering units, but in order to be applied to the calculations it must be set as a %, this can be calculated in the following way:

$$\% \text{ Deadband} = \frac{\text{Deadband (eng units)}}{\text{Eng Hi} - \text{Eng Lo}} \times 100$$

Minimum 'ON' time of integral action pulses (for a fixed control deviation)

$$= \frac{\text{Travel Time} \times \text{Deadband\% (in seconds)}}{\% \text{ Proportional Band}}$$

Minimum (approximate) time between integral action pulses (for a fixed control deviation)

$$= \frac{\text{Integral Action Time} \times \text{Deadband\% (in seconds)}}{2 \times \text{Control Deviation}}$$

Duration of the proportional step

$$= 2 \times \frac{(\% \text{ Control Deviation}) \times \text{Travel Time in seconds}}{(\% \text{ Proportional Band})}$$

% Control Deviation

$$= \frac{\text{Setpoint} - \text{Process Variable}}{\text{Eng Hi} - \text{Eng Lo}} \times 100\%$$

**Ratio**  
**Bias**

The required valve position = (Ratio x PID O/P) + Bias.

**Note.** Applicable only for motorized valve with feedback – see page 21.

**Deadband**

**Example:** If the valve is set to be driven to the 50 % open position and the deadband is set to 4 %, the motor stops driving when the position feedback is 48 %. The deadband is between 48 % and 52 %.

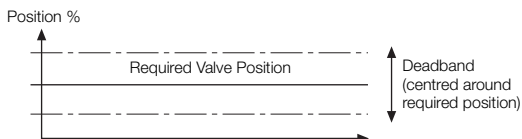

**Travel Time**

For motorized valve without feedback (see page 21), this parameter is used to control the valve movement.

For motorized valve with feedback, the time entered is compared with the actual valve movement. If the valve is sticking, a diagnostic message is generated (set *Travel Time* to 0 s to disable this feature).

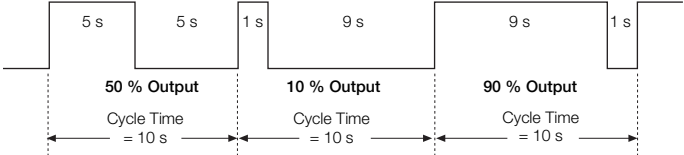

...Basic

<p><b>Loop 1 (2) Time Prop</b></p> <hr/> <p>Cycle Time 1</p> <p>Cycle Time 2</p>	<p>The active time of the output pulse is proportional to the value of the control output. With 100 % output the pulse is active for the complete cycle time, for example:</p>  <p><b>Note.</b> Applicable only if <i>Output Type</i> is <i>Time Prop</i> or <i>Split Output</i> (and one output is a relay or a digital output) – see page 24.</p>
<p><b>Alarm 1 (8)</b></p> <hr/> <p>Trip</p>	<p>The alarm trip level in engineering units. See <i>Process Alarm</i> (page 47) for parameter details.</p>

## 7 Advanced Level

### 7.1 Device Setup

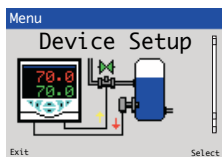

Provides access to standard setup parameters to determine the type of control / indication required. Also provides the ability to create non-standard configurations for special application requirements.

#### Initial Setup

App Template	<p>Application templates enable standard configurations for particular applications to be created as simply as possible. When a template is selected, the controller assumes the preset form for that template. The inputs and function blocks are soft-wired automatically to perform the selected function.</p> <p>See Section 8, page 64 for templates available to Extended and Dual functionality controllers.</p>
Loop 1 (2) Output Type	<p>The appropriate output function block, relay, digital and analog outputs are configured and soft-wired.</p> <p><i>Loop 2 Output Type</i> is available only if a <i>Dual Loop</i> application template is selected – see Section 8, page 64 for template details.</p> <p>See Appendix D, page 84 for output assignments.</p>
Loop 1 (2) Split O/P	<p><i>Loop 1 Split O/P</i> is available only if the <i>Loop 1 Output Type</i> is <i>Split Output</i>.</p> <p><i>Loop 2 Split O/P</i> is available only if a <i>Dual Loop</i> or <i>Cascade</i> application template is selected and the <i>Loop 2 Output Type</i> is <i>Split Output</i>.</p> <p>These types of outputs split the <i>Control (PID)</i> output signal (see page 20) into 2 signals. The linear relationship between the PID O/P and the 2 outputs can be configured in the <i>Control</i> configuration – see page 36.</p> <p>See Appendix D, page 84 for output assignments.</p>
Instrument Tag	<p>A 16-character alphanumeric tag, displayed in the title bar on <i>Operator</i> pages – see page 16.</p>
Loop 1 (2) Tag	<p>Available only if a <i>Cascade</i> or <i>Dual Loop</i> application template is selected – see Section 8, page 64 for template details.</p> <p>The tag is displayed in <i>Operator</i> pages – see page 16.</p>
Mains Freq	<p>Used to set the internal filters to reduce mains power frequency interference.</p>

...Device Setup / ...Basic Setup

<b>Config Action</b>	The <i>Config Action</i> parameter is used to determine how the controller and controller outputs behave when the <i>Advanced</i> level is entered – see page 24.
<i>Continue</i>	The controller continues to operate as in the operator level. Outputs continue to operate as normal.
<i>Hold</i>	Puts the controller into <i>Manual</i> control mode. When the <i>Advanced</i> level is exited, the controller returns to the pre-configuration mode of operation. Digital, relay and analog outputs are held at their value / state when configuration mode is entered.
<i>Inactive</i>	Puts the controller into <i>Manual</i> control mode. When the <i>Advanced</i> level is exited, the controller returns to the pre-configuration mode of operation. Digital and relay outputs are turned off. Analog outputs are set to 0 mA.
<b>Custom Template</b>	If this parameter is enabled, it enables the internal function blocks to be re-linked to create custom configurations for special application requirements. These sources are configured in <i>Device Setup / Custom Config</i> – see below.
<b>Reset to Defaults</b>	Resets all configuration parameters to their default values.
<b>Security Setup</b>	3 Security access levels are provided, each protected by a password of up to 6 alphanumeric characters. <b>Note.</b> Passwords <i>Basic</i> and <i>Advanced</i> level are not set at the factory and must be entered by the end user(s).
<b>Basic Password</b>	<i>Basic</i> level provides access to the <i>Basic</i> level parameters – see Section 6, page 18.
<b>Advanced Password</b>	Provides access to all configuration parameters – see Section 7, page 24.
<b>Reset Passwords</b>	Resets all passwords to factory values.
<b>Custom Config</b>	
<i>Loop 1 (2) PV</i>	Sets the source for the process variable.
<i>Loop 1 (2) Split O/P</i>	Sets the source for output to the split output function block.
<i>Loop 1 (2) Valve Mode</i>	Sets the valve operation mode, <i>Feedback</i> or <i>Boundless</i> – see page 21.
<i>Loop 1 (2) Valve O/P</i>	Sets the control input to the valve function block.
<i>Loop 1 (2) Valve FB</i>	Sets the source for position feedback input.
<i>Loop 1 (2) TP OP1</i>	Sets the source for control input to the time proportioning block for <i>Output 1</i> – see page 24.
<i>Loop 1 (2) TP OP2</i>	Sets the source for control input to the time proportioning block for <i>Output 2</i> see page 24.
<i>Loop 1 (2) RSP</i>	Sets the source for the remote (external) setpoint.

## 7.2 Display

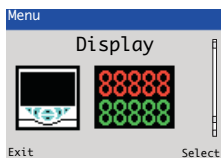

Used to setup the operator page, displayed language and display hardware settings.

<b>Language</b>	Selects the language on the controller's local display.
<b>Operator Templates</b>	Enables up to 4 operator pages to be configured to suit the application requirements.
<b>Page 1 (4) Template</b>	<p>The operator template type.</p> <p>The functions available in each template type are displayed as abbreviations, for example:</p> <p><i>Single PV, SP &amp; OP</i></p> <p>Key to abbreviations:</p> <ul style="list-style-type: none"><li>■ PV = process variable</li><li>■ SP = setpoint</li><li>■ MOP = master output (A/M status and analog backups)</li><li>■ OP = control output</li><li>■ DV = disturbance variable (input to feedforward)</li><li>■ Overview = displays PV, SP and OP for both loops</li><li>■ Loop 1 (2) = displays PV, SP and SP for Loop 1 (2)</li><li>■ AR = actual ratio</li><li>■ DR = desired ratio</li><li>■ Chart = trend display of up to 2 signals</li></ul>

...Display

**Operator Functions**

<b>Autoscroll</b>	When enabled ( <i>On</i> ), <i>Operator</i> pages (see page 16) are scrolled continuously at intervals of 10 seconds per page.
<b>Soft Key Function</b>	Assigns a dedicated function to the Navigation key (right) – see page 6.
<i>Configuration</i>	Displays the <i>Access Level</i> enabling selection of configuration levels – see page 17.
<i>Auto/Manual</i>	Toggles between <i>Auto</i> and <i>Manual</i> control modes.
<i>Local / Remote</i>	Toggles between <i>Local</i> and <i>Remote</i> setpoint modes.
<i>Scroll View</i>	Scrolls through each available <i>Operator</i> view.
<i>Alarm Ack</i>	Acknowledges all active unacknowledged alarms.
<i>Toggle Signal</i>	Provides a source that toggles between 2 states – can be assigned to outputs or used to select sources.
<i>Edge Signal</i>	Provides an edge-triggered source that is active on key press. Can be assigned to outputs or used to select sources
<b>Auto Manual Enable</b>	Turns on / off the ability for <i>Auto / Manual</i> control mode to be changed in <i>Operator Level</i> .
<b>Local Remote Enable</b>	Turns on / off the ability for local / remote setpoint mode to be changed in <i>Operator Level</i> .
<b>Alarm Ack. Enable</b>	Turns on / off the ability to acknowledge alarms from the front panel.
<b>Totalizer Stop/Go</b>	Turns on / off the ability to start / stop the totalizer.
<b>Totalizer Reset</b>	Turns on / off the ability to reset the totalizer.
<b>SP Adjust Enable</b>	Turns on / off setpoint adjustment in the <i>Operator Level</i> .

...Display

<b>Chart View</b>	<p>Enables the operator level chart function to be configured.</p> <p>The chart can display the trend for 1 or 2 analog values and be scaled independently of the engineering ranges for the analog values selected.</p> <p><b>Note.</b> Enabled only if <i>Operator Template, Chart</i> is selected – see page 26.</p>
<hr/>	
<b>Channel 1 (2)</b>	
<b>Source</b>	Selects the analog value to be shown on the chart – see Appendix A.2, page 80 for details of analog sources.
<b>Scale Low*</b>	Sets the minimum value on the y-axis for this channel.
<b>Scale High*</b>	Sets the maximum value on the y-axis for this channel.
<b>Tag</b>	A 3-character, alphanumeric tag used to identify the parameter on the chart.
<b>Sample Rate</b>	Selected from 1, 10, 30 seconds; 1, 2, 3, 4, 5 minutes.
<hr/>	
<b>Settings</b>	Adjusts display settings to suit ambient conditions.
<b>Brightness</b>	Increases / Decreases the display brightness to suit local environmental conditions.
<b>Contrast</b>	Increases / Decreases the display contrast to suit local environmental conditions (enabled for CM30 and CM50 only).

\*When the controller is setup for the first time, the *Scale Low* and *Scale High* values default to match the engineering range.

...Display

<b>Date &amp; Time</b>	Sets the date format, local time / date and daylight saving start / end times.
<b>Date Format</b>	Selected from: DD-MM-YYYY, MM-DD-YYYY, YYYY-MM-DD.
<b>Time &amp; Date</b>	Sets the controller's time and date.
<b>Daylight Saving</b>	Sets daylight saving parameters.
<b>DS Region</b>	
<i>Off</i>	Daylight saving is disabled.
<i>Europe</i>	Standard daylight saving start and end times are selected for Europe automatically.
<i>USA</i>	Standard daylight saving start and end times are selected for USA automatically.
<i>Custom</i>	Used to create custom daylight saving start and end times manually for regions other than Europe or USA. <b>Note.</b> Enables <i>Daylight Start Time</i> and <i>Daylight End Time</i> parameters.
<b>DS Start Time</b>	The start time selected from 1-hour increments. <b>Note.</b> Displayed only when the <i>DS Region</i> sub-parameter is <i>Custom</i> .
<b>DS Start Occur</b> <b>DS End Occur</b>	The day within the month that daylight starts / ends – for example, to set daylight saving to start (or end) on the second Monday of the selected month, select <i>Second</i> .
<b>DS Start Day</b> <b>DS End Day</b>	The day of the month daylight saving starts / ends. <b>Note.</b> The <i>Daylight Start / End Occur</i> parameters must be valid within the month for the selected day.
<b>DS Start Month</b> <b>DS End Month</b>	The month daylight saving starts / ends.

...Display

<b>Customise Pages</b>	The contents and appearance of each <i>Operator Page</i> (see page 16) can be customized to meet particular user requirements.																																																						
<b>Page Number</b>	Selects the <i>Operator Page</i> (1 to 4) to be customized.																																																						
<b>Template Type</b>	Selects one of the standard operator page templates. Template codes: <hr/> A = Analog value, T = Totalizer value, S = State value (see <i>Parameters / Type</i> below). <table border="0"> <tr> <td>A (Style 1)</td> <td>A,A (Style 1)</td> <td>A,A,A (Style 1)</td> <td>A,A,A,A (Style 1)</td> <td>A,A,A,A,A</td> <td>A,A,A,A,A,A</td> </tr> <tr> <td>A (Style 2)</td> <td>A,A (Style 2)</td> <td>A,A,A (Style 2)</td> <td>A,A,A,A (Style 2)</td> <td>A,A,A,A,S</td> <td>A,A,A,A,A,S</td> </tr> <tr> <td></td> <td>A,A (Style 3)</td> <td>A,A,A (Style 3)*</td> <td>A,A,A,A (Style 3)</td> <td></td> <td>A,A,S,A,A,A</td> </tr> <tr> <td></td> <td>A,A (Style 4)</td> <td>A,A,A (Style 4)</td> <td>A,A,A,T**</td> <td></td> <td>A,A,S,A,A,S</td> </tr> <tr> <td></td> <td>A,T (Style 1)</td> <td>A,A,S (Style 1)</td> <td>A,A,T,T</td> <td></td> <td></td> </tr> <tr> <td></td> <td></td> <td>A,A,S (Style 2)</td> <td></td> <td></td> <td>Chart</td> </tr> <tr> <td></td> <td></td> <td>A,A,T</td> <td></td> <td></td> <td></td> </tr> <tr> <td></td> <td></td> <td>A,T,T</td> <td></td> <td></td> <td></td> </tr> <tr> <td></td> <td></td> <td>*CM50 only</td> <td>**CM30 only</td> <td></td> <td></td> </tr> </table> <hr/>	A (Style 1)	A,A (Style 1)	A,A,A (Style 1)	A,A,A,A (Style 1)	A,A,A,A,A	A,A,A,A,A,A	A (Style 2)	A,A (Style 2)	A,A,A (Style 2)	A,A,A,A (Style 2)	A,A,A,A,S	A,A,A,A,A,S		A,A (Style 3)	A,A,A (Style 3)*	A,A,A,A (Style 3)		A,A,S,A,A,A		A,A (Style 4)	A,A,A (Style 4)	A,A,A,T**		A,A,S,A,A,S		A,T (Style 1)	A,A,S (Style 1)	A,A,T,T					A,A,S (Style 2)			Chart			A,A,T						A,T,T						*CM50 only	**CM30 only		
A (Style 1)	A,A (Style 1)	A,A,A (Style 1)	A,A,A,A (Style 1)	A,A,A,A,A	A,A,A,A,A,A																																																		
A (Style 2)	A,A (Style 2)	A,A,A (Style 2)	A,A,A,A (Style 2)	A,A,A,A,S	A,A,A,A,A,S																																																		
	A,A (Style 3)	A,A,A (Style 3)*	A,A,A,A (Style 3)		A,A,S,A,A,A																																																		
	A,A (Style 4)	A,A,A (Style 4)	A,A,A,T**		A,A,S,A,A,S																																																		
	A,T (Style 1)	A,A,S (Style 1)	A,A,T,T																																																				
		A,A,S (Style 2)			Chart																																																		
		A,A,T																																																					
		A,T,T																																																					
		*CM50 only	**CM30 only																																																				
<b>Titlebar Tag</b>	A user-programmable, 16-character alphanumeric tag.																																																						
<b>Parameters</b>																																																							
<b>Parameter Number</b>	1 to 4 (depending on the <i>Template Type</i> selected).																																																						
<b>Type</b>	Enables some parameter types to be modified to enable more flexibility in the available display formats: <ul style="list-style-type: none"> <li>■ Parameters set as <i>Totalizer value</i> by the <i>Template Type</i> can be changed to analog or state parameters.</li> <li>■ Parameters set as <i>State value</i> by the <i>Template Type</i> can be changed to an analog parameter.</li> </ul>																																																						
<b>Source</b>	Selects the signal to be displayed.																																																						
<b>Color</b>	Selects the color to be used to display this parameter. Color codes: <hr/> <table border="0"> <tr> <td>Black</td> <td>Red</td> <td>Yellow</td> <td>Green</td> <td>Cyan</td> </tr> <tr> <td>Blue</td> <td>Magenta</td> <td>White</td> <td>Grey</td> <td></td> </tr> <tr> <td>Dark Cyan</td> <td>Dark Magenta</td> <td>Dark Grey</td> <td>Dark Yellow</td> <td>Dark Green</td> </tr> <tr> <td>Dark Blue</td> <td>Dark Red</td> <td></td> <td></td> <td></td> </tr> <tr> <td>Theme RGB*</td> <td>Theme RYG**</td> <td></td> <td></td> <td></td> </tr> </table> <hr/> *For use with <i>State</i> parameter types: <ul style="list-style-type: none"> <li>■ State 0 tag is shown in red.</li> <li>■ State 1 tag is shown in green.</li> <li>■ State 2 tag is shown in blue.</li> </ul> Applicable only if <i>Template Type</i> = <i>State</i> . **For use with <i>State</i> parameter types: <ul style="list-style-type: none"> <li>■ State 0 tag is shown in red.</li> <li>■ State 1 tag is shown in yellow.</li> <li>■ State 2 tag is shown in green.</li> </ul> Applicable only if <i>Template Type</i> = <i>State</i> .	Black	Red	Yellow	Green	Cyan	Blue	Magenta	White	Grey		Dark Cyan	Dark Magenta	Dark Grey	Dark Yellow	Dark Green	Dark Blue	Dark Red				Theme RGB*	Theme RYG**																																
Black	Red	Yellow	Green	Cyan																																																			
Blue	Magenta	White	Grey																																																				
Dark Cyan	Dark Magenta	Dark Grey	Dark Yellow	Dark Green																																																			
Dark Blue	Dark Red																																																						
Theme RGB*	Theme RYG**																																																						



...Display / ...Customise Pages / ...Parameters

<b>Tag</b>	A user-programmable, 3-character alphanumeric tag used to identify each parameter.																								
<b>State 0 Tag</b>	A user-programmable, 8-character alphanumeric tag displayed when the state of the selected parameter has a value of 0.																								
<b>State 1 Tag</b>	A user-programmable, 8-character alphanumeric tag displayed when the state of the selected parameter has a value of 1.																								
<b>State 2 Tag</b>	A user-programmable, 8-character alphanumeric tag displayed when the state of the selected parameter has a value of 2.																								
<hr/>																									
<b>Bargraphs</b>	Up to 2 bargraphs can be configured. On some <i>Template Types</i> (see page 30), it is not possible to display one or both of the bargraphs.																								
<hr/>																									
<b>Bargraph Number</b>	Selects the bargraph to be customized.																								
<b>Type</b>	Selects the type of bargraph (if required). [Off, Standard, Deviation]																								
	<div style="display: flex; justify-content: space-around; align-items: flex-start;"> <div style="text-align: center;"> <p>Standard Bargraph (2 Shown)</p> </div> <div style="text-align: center;"> <p>Deviation Bargraph</p> </div> </div>																								
<b>Source</b>	Selects the analog signal to be represented on the bargraph (if a <i>Deviation</i> bargraph type is selected, select deviation signals only).																								
<b>Color</b>	Selects the color to be used on the bargraph. <b>Note.</b> <i>Theme RGB</i> and <i>Theme RYG</i> (see page 30) cannot be used with bargraphs.																								
<hr/>																									
<b>Icons</b>	Used to configure up to 8 icons (with some custom display templates it is not possible to display all 8 icons).																								
<b>Type</b>	Selects the type of icon to be displayed. Icon types:																								
	<table border="1" style="width: 100%; border-collapse: collapse;"> <tr> <td>Off</td> <td></td> <td></td> <td></td> </tr> <tr> <td>Loop 1 Local SP</td> <td>Loop 1 Auto/Manual</td> <td>Loop 1 Local/Remote</td> <td></td> </tr> <tr> <td>Loop 2 Local SP</td> <td>Loop 2 Auto/Manual</td> <td>Loop 2 Local/Remote</td> <td></td> </tr> <tr> <td>Loop 1 Feedforward</td> <td>Loop 2 Feedforward</td> <td>Loop 1 Valve Status</td> <td>Loop 2 Valve Status</td> </tr> <tr> <td>Loop 1 Totalizer</td> <td>Loop 2 Totalizer</td> <td>Loop 1 Ration L/R</td> <td>Loop 2 Ration L/R</td> </tr> <tr> <td>Loop 1 Track Status</td> <td>Loop 2 Track Status</td> <td>Blank</td> <td></td> </tr> </table>	Off				Loop 1 Local SP	Loop 1 Auto/Manual	Loop 1 Local/Remote		Loop 2 Local SP	Loop 2 Auto/Manual	Loop 2 Local/Remote		Loop 1 Feedforward	Loop 2 Feedforward	Loop 1 Valve Status	Loop 2 Valve Status	Loop 1 Totalizer	Loop 2 Totalizer	Loop 1 Ration L/R	Loop 2 Ration L/R	Loop 1 Track Status	Loop 2 Track Status	Blank	
Off																									
Loop 1 Local SP	Loop 1 Auto/Manual	Loop 1 Local/Remote																							
Loop 2 Local SP	Loop 2 Auto/Manual	Loop 2 Local/Remote																							
Loop 1 Feedforward	Loop 2 Feedforward	Loop 1 Valve Status	Loop 2 Valve Status																						
Loop 1 Totalizer	Loop 2 Totalizer	Loop 1 Ration L/R	Loop 2 Ration L/R																						
Loop 1 Track Status	Loop 2 Track Status	Blank																							
<b>Color</b>	Selects the color of each icon used on the display.																								
<hr/>																									
<b>Page Colors</b>	The <i>Icons</i> parameter is used to define the icons displayed and to select icon colors.																								
<hr/>																									
<b>Background Color</b>	Selects the background color of the <i>Operator Page</i> – see page 16.																								
<b>Titlebar Color</b>	Selects the background color of the title bar.																								
<b>Title Tag Color</b>	Selects the color of the title bar tag.																								
<b>Softkey Color</b>	Selects the color for the <i>Soft Key</i> icons – see page 27.																								

## 7.3 Input/Output

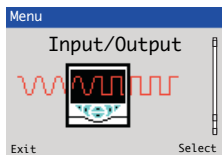

Enables analog and digital inputs / outputs and relays to be configured.

### Analog Inputs

#### Analog Input 1 (4)\*

**Input Type** *Millivolts, Milliamps, Volts, Resistance (Ohms), RTD, Thermocouple, Digital volt-free, 24V Digital, Freq. Input, Pulse Input.*

Additional *Input Type* comments:

*Digital Volt Free* Acts as a digital input.

*Freq. Input* Sets the maximum frequency and equivalent flow rate in the engineering range 0 to 6000 Hz. (A frequency of 0.01 to 6 KHz can be used to create an analog value.)

*Pulse Input* This parameter counts pulses and is recommended only for use with electromagnetic flowmeters.

**Elect. Low** Sets the required electrical range.

**Note.** Applicable only to *Millivolts, Milliamps, Volts* and *Ohms*.

Linear Inputs	Standard Analog Input	Accuracy (% of Reading)
Millivolts	0 to 150 mV	0.1 % or $\pm 20 \mu V$
Milliamps	0 to 50 mA	0.2 % or $\pm 4 \mu V$
Volts	0 to 25 V	0.2 % or $\pm 1 mV$
Resistance $\Omega$ (low)	0 to 550 $\Omega$	0.2 % or $\pm 0.1 \Omega$
Resistance $\Omega$ (high)	0 to 10 k $\Omega$	0.1 % or $\pm 0.5 \Omega$

**Elect. High** Sets the required electrical range.

**Note.** Applicable only to *Millivolts, Milliamps, Volts* and *Freq. Input*.

**Linearizer** Selects the linearizer type required to condition the input signal.

**Notes.** For thermocouple applications using an external fixed cold junction, set *Input Type* to *Millivolts* and select the appropriate linearizer type.

Not applicable for *Pulse Input, Digital volt-free, 24V Digital* parameters.

**Eng Units** The selected units are used by the linearizer and displayed in the *Operator* pages.

Not applicable for: *Pulse Input, Digital volt-free, 24V Digital* parameters.

Thermocouple and RTD inputs are restricted to *deg C, deg F, Kelvin* – see Appendix C, page 83 for analog input (engineering) units.

**Eng. Dps** Engineering decimal places – selects the resolution required to be displayed for the input value.

\*Analog Inputs 2 to 4: *Freq Input, Pulse Input* and *Resistance* not available. A *Thermocouple* input type can be set only if the first input is set to *Thermocouple*.

...Input/Output / ...Analog Inputs / ...Analog Input 1 (4)

<b>Eng. Low</b>	Specifies the engineering low (minimum) value. For example, for an electrical input range of 4.0 to 20.0 mA, representing a pressure range of 50 to 250 bar, set the <i>Eng Low</i> value to 50.0 and the <i>Eng High</i> value to 250.0. Not applicable for <i>Pulse Input</i> – see page 32.
<b>Eng. High</b>	Specifies the engineering high (maximum) value. See <i>Eng Low</i> for range example. Not applicable for <i>Pulse Input</i> .
<b>Pulse Units</b>	Selects the unit of measure for the pulse input type.
<b>Pulse / Unit</b>	Sets the number of pulses required to represent 1 pulse unit (as set above). For example, if <i>Pulse Units</i> = Kl and <i>Pulse / Unit</i> = 10.00000000, each pulse represents 0.1 Kl, 10 pulses = 1 Kl.
<b>Broken Sensor</b>	If an input failure occurs, the input value can be configured to drive in a set direction.
<i>None</i>	No action taken.
<i>Automatic</i>	If the value of failed input is below <i>Eng Low</i> , the input value is driven to minimum downscale value; otherwise it is driven to the maximum upscale value.
<i>Upscale</i>	The input is driven to the maximum upscale value.
<i>Downscale</i>	The input is driven to the minimum downscale value.
<b>Filter Time</b>	The input is averaged over the time set.
<b>Fault Detect</b>	Sets a tolerance level (in % of engineering range) to allow for deviation of the input signal above or below the engineering range before an input failure is detected.
<b>Zero Adjustment</b>	The <i>Zero Adjustment</i> and <i>Span Adjustment</i> parameters enable fine tuning of the inputs to eliminate system errors. Apply a known input value and adjust until the required input value is displayed.  Normally, <i>Zero Adjustment</i> is used with input values close to <i>Eng Low</i> (adjustment is performed by applying an offset to the reading) and <i>Span Adjustment</i> is used with values close to <i>Eng High</i> (adjustment is performed by applying a multiplier to the reading).
<b>Span Adjustment</b>	

...Input/Output

<b>Analog Outputs</b>	The analog outputs can be configured to retransmit any analog value and have a configurable range from 0 to 24 mA. Output 1 can also be configured to function as a digital output.
<b>Analog Output 1 (2)</b>	<b>Note.</b> <i>Analog Output 2</i> is available only if an option board is fitted – see pages 12 (CM30) and 13 (CM50) for option board details.
<b>Output Type</b>	Selects the output type required (applicable only to Analog Output 1).
<b>Source</b>	Selects the parameter to be assigned to the output – see Appendix A, page 79 for description of sources.
<b>Elect. Low*</b>	The current output required when the source value is equal to the <i>Eng Low</i> value – see page 33.
<b>Elect. High*</b>	The current output required when the source value is equal to the <i>Eng High</i> value – see page 33.
<b>Auto Eng Range*</b>	If enabled ( <i>On</i> ) the <i>Eng High</i> and <i>Eng Low</i> values for the output are set automatically to the engineering range values of the source.
<b>Eng Low*</b>	The minimum engineering range output value.
<b>Eng High*</b>	The maximum engineering range output value.
<b>Polarity**</b>	Sets the polarity of the output signal. If set to <i>Negative</i> , the output is energized when source is inactive. If set to <i>Positive</i> , the output is energized when source is active.

\*Not applicable if *Output Type* is *Digital* or *Source* is *None*.

\*\*Not applicable if *Output Type* is *Analog* or *Source* is *None*.

...Input/Output

**Digital I/O**

**Digital IO 1 (6)**

<b>Type</b>	Sets the <i>Digital IO</i> to operate as an output or an input.
<i>Off</i>	No action taken.
<i>Output</i>	The <i>Digital IO</i> operates as an output.
<i>Volt Free</i>	High input detected when volt free switch across input is closed.
<i>24 Volt</i>	Digital input low <5V, high> 11 V (maximum input 30 V).
<i>TTL</i>	Digital input low <0.8V, high> 2 V.
<b>Output Source</b>	Selects the digital signal to be assigned to the output – see Appendix A.1, page 79 for description of sources.
<b>Polarity</b>	Sets the polarity of the output signal.
<i>Positive</i>	For an output, if the source is active the output is high. For an input, if a high signal is detected the input is active.
<i>Negative</i>	For an output, if source is inactive the output is high. For an input, if a low signal is detected the input is active.

**Relays**

**Relay 1 (4)**

<b>Source</b>	Selects the digital signal to be assigned to the relay – see Appendix A.1, page 79 for description of sources.
<b>Polarity</b>	Sets the polarity of the relay.
<i>Positive</i>	If the source is active the relay is energized.
<i>Negative</i>	If the source is inactive the relay is energized.

## 7.4 Control

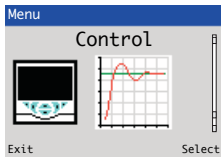

Enables the setpoints, control functions and outputs to be configured.

<p><b>Loop 1 (2) Setpoints</b></p>	<p>The controller can have up to 4 independent local setpoint values, remote setpoint functionality and the ability to limit the absolute values and rate of change of the control setpoint.</p> <p><i>Loop 2 Setpoint</i> settings apply to the slave controller if a <i>Cascade</i> application template is selected – see Section 8, page 64 for template options.</p> <p><b>Note.</b> This section is not applicable for <i>Auto/Manual Station</i>, <i>Single &amp; Dual Indicator</i>, <i>Ratio Station templates</i> – see Section 8, page 64 for template options.</p>
<p><b>Low Limit</b> <b>High Limit</b></p>	<p>The setpoint limit parameters define the maximum and minimum values for the local and/or remote setpoints. The setpoint limits do not apply when in <i>Manual</i> control mode with local setpoint tracking enabled. If the setpoint is outside of limits when <i>Auto</i> control mode is selected, the setpoint value can be adjusted only towards its limits.</p> <p>Once within the limits they apply as normal.</p>
<p><b>No. of Local SP's</b></p>	<p>Selects the number of independent local (internal) setpoints required.</p> <p>The local setpoints can be selected from the <i>Operator</i> level menu or via a digital signal.</p>
<p><b>Local Setpoint 1 (4)</b></p>	<p>If the value is adjusted in the <i>Operator</i> level, its value here is also updated.</p>
<p><b>Track Mode</b></p> <p><i>Off</i></p> <p><i>Local</i></p> <p><i>Remote</i></p> <p><i>Local and Remote</i></p>	<p>The local (internal) setpoint can track another value according to the setpoint tracking mode selected.</p> <p><i>Off</i> No tracking.</p> <p><i>Local</i> The local (internal) setpoint tracks the process variable when <i>Manual</i> control mode is selected.</p> <p><i>Remote</i> The local (internal) setpoint tracks the remote (external) setpoint when in <i>Remote Setpoint</i> mode. If the controller is put into <i>Manual</i> control mode the setpoint reverts from <i>Remote</i> to <i>Local</i>. This also applies to the local and remote ratio when a ratio controller template is selected – see Section 8, page 64 for template details.</p> <p><b>Note.</b> Available only if the template selected has remote setpoint or ratio functionality.</p> <p><b>Note.</b> Available only if the template selected has remote setpoint or ratio functionality.</p>

**...Control / ...Loop 1 (2) Setpoints**

<b>RSP Ratio</b>	When the remote (external) setpoint is selected the control setpoint value is: $(\text{ratio} \times \text{remote setpoint input}) + \text{bias}$	
<b>RSP Bias</b>	Sets the remote setpoint bias in engineering units – see Appendix C, page 83 for description of analog input (engineering) units.	
<b>RSP Fault Action</b>	The action required when a fault occurs with the remote setpoint.	
<i>No Action</i>	No fault action.	
<i>Local</i>	Selects the local (internal) setpoint mode.	
<i>Local Default</i>	Selects the local (internal) setpoint mode and sets its value to the default setpoint.	
<b>Default Setpoint</b>	Sets the value required for the local (internal) setpoint under remote setpoint fault conditions.	
<b>Ramp Mode</b>	The ramping setpoint facility can be used to prevent a large disturbance to the control output when the setpoint value is changed. The rate set applies to both the local and the remote setpoints.	
	<p style="text-align: center;">*Example: Ramp Rate = 200 Increments / Hour</p>	
<b>Ramp Rate</b>	Sets the ramp rate required in engineering units / hour	
<b>Select Sources</b>	The selection of local setpoints and the changing of setpoint mode between local (internal) and remote (external) can be controlled by digital signals; either from internal digital signals (for example, alarm states) or from external signals via digital inputs (or digital communications) – see Appendix A.1, page 79 for description of sources.	
<b>LSP 1/2 Toggle</b>	The source required to select either local setpoint 1 (LSP1) or local setpoint 2 (LSP2). This source is level-triggered. A low signal locks the local setpoint as local setpoint 1 (LSP1) and a high signal locks it as local setpoint 2 (LSP2).	
<b>LSP1 (4) Select</b>	The source required to select local setpoint 1 (LSP1) as the current local setpoint. Selection is made on the rising edge of the digital signal.	
<b>Local Select</b>	The source required to select local setpoint mode (or local ratio mode when the ratio controller / station template is selected).	

...Control / ...Loop 1 (2) Setpoints / ...Select Sources

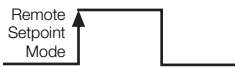
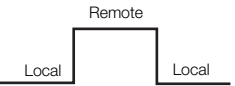
<b>Remote Select</b>	The source required to select remote setpoint mode (or remote ratio) mode.	
<b>Loc/Rem Toggle</b>	<p>The source required to select either local or remote setpoint mode. This source is level-triggered.</p> <p>A low signal locks the controller in local setpoint mode and a high signal locks it in remote setpoint mode. The edge-triggered local and remote selection sources and the front panel keys do not operate when this function is used.</p> <p>If the remote setpoint fails while selected using this digital selection and the <i>RSP Fault Action parameter</i> is not set to <i>No Action</i> (see page 37) the mode changes to <i>Local</i>.</p> <p>As soon as the remote setpoint is no longer in a failed state it reverts to remote mode (if it is still selected by this function).</p>	

**Loop 1 (2) Control**

**Overview**

*Loop Control* configures the basic type of control required and the *PID* and *Autotune* settings.

The controller can be configured to perform different types of control:

**On/Off Control – see page 39**

Simple 2-state thermostat-type control with configurable hysteresis to prevent wear on the final control element. This control type does not use *PID* control algorithm (see page 20) and can be used where precise control is not required or the process is very easy to control.

**Note.** Available only when the *O/P* type is set to time proportioning – see page 23.

**PID (Proportional, Integral and Derivative) Control with Fixed Parameters – see page 20**

If the process is linear (its dynamic characteristics are independent of the working point) and do not change with time, *PID* with fixed parameters can be used.

**Gain Scheduling PID Control – see page 40**

If the process involves a non-linear valve or other type of non-linear device, the process dynamics change according to the working range (it is non-linear). Therefore, the controller also requires different parameters in different working ranges. If the non-linearity can be related to a reference signal, *PID* control with *Gain Scheduling* can be used. For instances where the process dynamics also vary with time it can be combined with adaptive control.

**pPI (Predicting Proportional plus Integral) Control – see page 39**

This is a deadtime-compensating controller. the *pPI* controller provides short damping-time at a load or setpoint change. *pPI* cannot be used with the *Autotune* (see page 19) or *Adaptive Control* (see page 42) and should not be used with integrating processes. *pPI* can be used with *Gain Scheduling* for applications where the deadtime is varying in relation to another parameter, for example, with the rate of flow or conveyor belt speed.

**Feed Forward Control – see page 41**

To eliminate a disturbance that could be measured before it affects the process value use a *FeedForward* template (see page 64 for template options). To eliminate the measurable levels of disturbance, *FeedForward Adaptive Gain* or *Static Gain* can be used – see Section 8, page 41.

**Adaptive Control – see page 42**

*PID* control with adaptive *PID* settings. If the process has variable dynamic characteristics that cannot be related to a reference signal, use *PID* control with adaptive *PID* settings.

The *Autotune* function can be used to set the *PID* parameters for all types of control except *pPI*. If Adaptive control is selected, these *PID* parameters are used as starting values only.



...Control / ...Loop 1 (2) Control

<b>Control Type</b>	Selects the basic type of controller required.
<i>PID</i>	Standard proportional, integral and derivative control.
<i>pPI</i>	<i>pPI</i> controller:
<p><i>pPI</i> (predictive PI control) is a deadtime-compensating control for use when the process deadtime is longer than twice the dominant process time constant. Unlike other deadtime compensation algorithms, <i>pPI</i> does not require a process model to be specified; it creates its own process model from proportional, integral and deadtime settings. If the deadtime is varying, the <i>pPI</i> controller can be combined with gain scheduling. The <i>Autotune</i> function is not used when <i>pPI</i> control is configured.</p> <p>The <i>pPI</i> controller is easy to tune, first by making a step response test on the process and then setting the controller parameters by observation. After tuning, the <i>pPI</i> controller can be adjusted manually. In most cases a decrease in proportional band or a decrease in integral time gives faster control but poorer damping.</p> <p>From a steady state condition, make a step change in the output from the neutral value (<math>u_0</math>) to a new value (<math>u_1</math>). Observe the process value (<math>y</math>) and make the following calculations:</p> <div style="display: flex; align-items: center; justify-content: center;"> <div style="margin-right: 20px;"> <math display="block">\Delta y = y_1 - y_0</math> <math display="block">\Delta u = u_1 - u_0</math> <math display="block">T = t_2 - t_1</math> <math display="block">L = t_1 - t_0</math> </div> </div>	
<p>By determining the 4 key parameters: L, T, <math>\Delta</math> and <math>\Delta u</math> from a step response, the 3 process parameters: static gain <math>K_p</math>, dominant time constant <math>T_p</math> and deadtime <math>L_p</math> can be determined according to the following expressions:</p> $K_p = \frac{\Delta y}{\Delta u} \quad T_p = T \quad L_p = L$	
<p>Knowing these, the <i>pPI</i>'s parameters can be calculated easily:</p> <ul style="list-style-type: none"> <li>Proportional band = <math>100 \times K_p</math></li> <li>Integral time = <math>T_p</math></li> <li>Derivative (deadtime) = <math>L_p</math></li> </ul>	
<p><b>Notes.</b></p> <ul style="list-style-type: none"> <li><math>y_0</math> and <math>y_1</math> are expressed in % of engineering range.</li> <li>When <i>pPI</i> is selected, the derivative time is used to set the deadtime.</li> </ul>	
<i>On/Off</i>	A simple 2-state control.

...Control / ...Loop 1 (2) Control

<b>Control Action</b>	If the required controller action is known it can be set using this parameter. Otherwise it can be set to <i>Unknown</i> and <i>Autotune</i> (see page 19) determines and selects the correct action.
<i>Direct</i>	For applications where an increasing process variable requires an increasing output to control it.
<i>Reverse</i>	For applications where an increasing process variable requires a decreasing output to control it.
<i>Unknown</i>	For applications where the control action is not known (run <i>Autotune</i> to set the control action automatically).

**On/Off Hysteresis**  
**Autotune** Refer to *Basic* Level on page 18.  
**PID**

**Gain Scheduling**

*Gain Scheduling* is used to improve the control of non-linear processes where the non-linearity is not time dependent. Processes with time-dependent non-linearity can be controlled with adaptive control. The gain scheduler selects different *PID* parameters (see page 20) according to the value of a user-selected reference signal.

3 Different settings for *PID* parameters can be used, within 3 ranges set by the user-defined parameters (*Limit 1* and *Limit 2* [see page 41]) that are expressed in the engineering range of the *Gain Scheduling* (GSRef) reference signal. When the value of the reference signal passes one of the limits the next set of *PID* parameters is switched in.

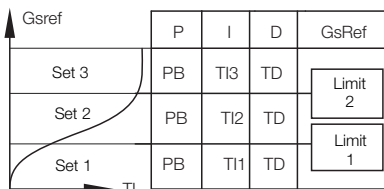

**How Gain Scheduling Works with Autotune**

When tuning is first performed, or after *Gain Scheduling* (or *Autotune* [see page 19]) is reset, the autotuner calculates *PID* parameters for the set selected by the GSRef signal and also copies those values into the other 2 sets of *PID* parameters.

If *Autotune* is then run with *Gain Scheduling* in one of the other 2 sets (see chart above), it calculates the *PID* values for the set selected by GSRef and also copies these to the set that was not calculated before.

If the *Autotune* is run with GSRef in the third set, it calculates the *PID* values for that set and leaves the other 2 sets untouched.

Any further running of the autotuner updates only the set that is selected at the time until *Gain Scheduling* (or *Autotune*) is reset. For example:

- If *Autotune* is run with  $GSRef < Limit\ 1$ , it calculates values for the first set of *PID* parameters and also copies these into the other 2 sets as well.
- If *Autotune* is then run with  $GSRef > Limit\ 2$ , it calculates *PID* values for the third set of *PID* parameters and also copies these to the second set.
- If *Autotune* is then run with GSRef between *Limit 1* and *Limit 2*, it calculates values for the second set of *PID* parameters and leaves the other 2 sets untouched.

...Control / ...Loop 1 (2) Control / ...Gain Scheduling

<b>Mode</b>	Turns the gain scheduling function <i>On</i> or <i>Off</i> .
<b>Source</b>	The <i>Gain Scheduling</i> (GSRef) reference signal – see Appendix A, page 79 for description of sources.
<b>Limit 1 (2)</b>	<i>Limit 1</i> – sets the point where the gain scheduler switches between the first and second sets of <i>PID</i> parameters.  <i>Limit 2</i> – sets the point where the gain scheduler switches between the second and third sets of <i>PID</i> parameters
<b>Reset</b>	If the gain scheduler is reset, the next time <i>Autotune</i> (see page 19) is used all 3 sets of the <i>PID</i> parameters are set – see page 20.

**FeedForward**

*FeedForward* can be used to eliminate disturbances that can be measured before they affect the process variable. *Feedforward Adaptive Gain* or *Static Gain* can be used to eliminate these measurable disturbances – see below.

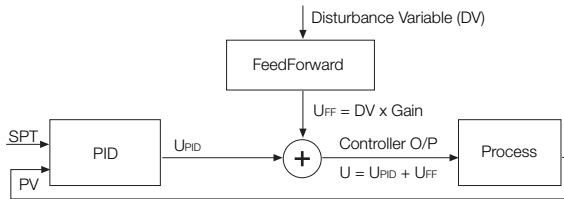

**Note.** *FeedForward* is enabled only if a *FeedForward* application template is enabled – see Section 8, page 64 for template options.

**Calculating Static Gain**

If the parameter mode is set to *Static Gain* (see page 42) the gain value can be determined using the following procedure:

- 1 Disable the *FeedForward* function by setting *Mode* to *Off* – see page 42.
- 2 Bring the system to a steady state.
- 3 Take note of the values of the disturbance variable (see DV, above) and the Controller output (identify them as v1 and u1 respectively).
- 4 Introduce a process disturbance, for example, by changing the process load, and then wait until the system is in a steady state.
- 5 Take note of the values of the *Disturbance Variable* and the Controller output (identify them as v2 and u2 respectively).
- 6 Use the following formula below to calculate the value of the *Static Gain* parameter:

$$\text{Gain} = \frac{U_1 - U_2}{V_1 - V_2}$$

- 7 Enable the *FeedForward* function by setting *Mode* to *Static Gain* – see page 42.

...Control / ...Loop 1 (2) Control / ...FeedForward

<b>Mode</b>	
<i>Off</i>	Feedforward control is disabled.
<i>Static Gain</i>	Gain applied by <i>FeedForward</i> block is a fixed value set by the user.
<i>Adaptive Gain</i>	Gain applied by the <i>FeedForward</i> block is set by the controller automatically. <i>Adaptive</i> feedforward can be used even if <i>Adaptive Control</i> (see page 42) has not been enabled. For <i>Adaptive</i> feedforward to operate, the system must first be tuned using <i>Autotune</i> – see page 19.  <i>Adaptive Gain</i> cannot be used with output tracking or with motorized valve without feedback. <i>FeedForward</i> (see page 41) with static gain can be used with motorized valve without feedback. <i>Adaptive Gain</i> cannot be used with <i>pPI</i> control – see page 39.
<b>Source</b>	
	Used to select source of the disturbance variable (DV) – see Appendix A, page 79 for description of sources.
<b>Gain</b>	
	Sets the gain to be used when in <i>Static Gain</i> mode.  In <i>Adaptive Gain</i> mode this value is set automatically by the controller.
<b>Reset Adaptive FF</b>	
	If the controller is moved to another application, <i>Adaptive</i> feedforward must be reset.
<b>Adaptive Control</b>	
<p><i>Adaptive Control</i> alters the <i>PID</i> parameters automatically (see page 20) if the process changes. It monitors process performance continuously and updates an internal process model. Based on this process model it calculates the optimum control parameters and adapts the <i>PID</i> settings accordingly. Changes to the <i>PID</i> settings occur as soon as the process dynamics change.</p> <p>Warnings are provided if the control parameters are changed by more than a set amount. This is important to detect conditions such as a blocked valve that could be interpreted by the adaptive controller as decreased process gain.</p> <p>Run <i>Autotune</i> (see page 19) to set the initial values for the adaptive controller. In a few cases, <i>Autotune</i> may not work well, for example in extremely noisy processes. In these cases, provide the adaptive controller with initial values of <i>Critical Period</i> and <i>Critical Gain</i> by the user – see procedure below.</p> <p>The adaptive controller uses the <i>Autotune Dynamics</i> setting to determine the optimum <i>PID</i> settings. If the process has a long deadtime, or a noisy measuring signal, select <i>Deadtime</i> or <i>PI</i> at the <i>Dynamics</i> parameter – see page 20.</p> <p>The adaptive controller does not work with Motorized Valve without Feedback output types – see Appendix D, page 84.</p> <p><i>Adaptive Control</i> cannot be used if output tracking mode <i>In Auto</i> is set (see page 46) because the adaptive controller receives false information.</p>	

...Control / ...Loop 1 (2) Control / ...Adaptive Control

<b>Mode</b>	Turns adaptive control <i>On</i> or <i>Off</i> .
<b>Critical Gain</b> <b>Critical Period</b>	Normally set by the autotuner, but can be set manually if necessary. A valid setting must be entered (either manually or using <i>Autotune</i> [see page 19] for the adaptive controller to function.  <b>Manual Calculation of Critical Gain and Critical Period</b> 1 Put the controller into <i>Manual</i> control mode. 2 Set the integral and derivative terms to off. 3 Set the <i>Proportional Band</i> to 100 % – see page 20. 4 Adjust the controller's output signal manually until the process variable equals the setpoint. 5 Read the current controller output value. 6 Set the controller's <i>Manual Reset</i> parameter to the value of the output – see page 20. 7 Put the unit into <i>Auto</i> control mode. 8 Change setpoint by a few percent (as the setpoint is changed in each iteration, keep the value relatively constant by alternating increases with decreases). 9 Observe the process variable and the output signal to see if the system oscillates. 10 If the system oscillates with a decreasing amplitude, decrease the proportional band and go to step 8. 11 If the system oscillates with a increasing amplitude, increase the proportional band and go to step 8. 12 If the system oscillates with a constant amplitude, read the controller's oscillation period time. This is the setting of the <i>Critical Period</i> parameter. Read the proportional band (Pb) setting and calculate the <i>Critical Gain</i> (Kc) as follows:  $K_c = \frac{100}{P_b}$
<b>Reset</b>	Resets the adaptive controller's internal parameters and process model to their default settings.
<hr/>	
<b>Misc.</b>	
<b>Loop Monitor</b>	A control loop performance monitor can be enabled to monitor the control loop for abnormal oscillations and creates a diagnostic warning if any occur. This function is automatic and does not require any user set up after it is activated.
<b>RSP Step Action</b>	Remote setpoint step behavior. Determines how the <i>PID</i> (see page 20) algorithm responds to a step change in the remote setpoint value.
<i>No P&amp;D</i>	During a step change in the remote setpoint value, the integral term only is applied.
<i>P&amp;D</i>	During a step change in the remote setpoint value proportional, integral and derivative terms are applied.

...Control / ...Loop 1 (2) Control

<b>Loop 1 (2) Output</b>	Used to set the output limits, tracking rates, slew rates and output action on power failure or process variable failure.
<b>Limits</b>	When used with split output the limits restrict the <i>PID</i> algorithm output (see page 20) before the split output range values are calculated.
<b>Limit Action</b>	Selects when the output limits should be applied ( <i>Off, Auto + Manual, Auto Only</i> ).
<b>Low Limit</b>	Set minimum controller output in %.
<b>High Limit</b>	Set maximum controller output in %.
<b>Failure Actions</b>	
<b>Power Recovery</b>	Used to select the default power failure mode required following a power interruption or failure.
<i>Last Mode</i>	The last <i>Power Recovery</i> mode selected.
<i>Man – Last</i>	<i>Manual</i> control mode using the last output before power failure.
<i>Man – 0 %</i>	<i>Manual</i> control mode with output set to 0 %.
<i>Man – 100 %</i>	<i>Manual</i> control mode with output set to 100 %.
<i>Man – Default</i>	<i>Manual</i> control mode with output set to default value.
<i>Auto Mode</i>	<i>Auto</i> control mode with integral term reset.
<i>Auto – Last</i>	<i>Auto</i> control mode with integral term restored to its last value before the power failure.
<i>Timed – Last</i>	If the power outage is < recovery time, the control mode before power down is selected. If the power outage is > recovery time, <i>Manual</i> control mode ( <i>Man – Last</i> ) is selected using the last output before the power failure.
<i>Timed – Default</i>	If the power outage is < recovery time, the control mode before power down is selected. If the power outage is > recovery time, <i>Manual</i> control mode ( <i>Man – Last</i> ) is selected using the default output value.
<i>Recovery Time</i>	Set time in seconds for use with Timed power recovery.
<b>PV Fail Action</b>	Determines the controller output when the process variable input fails.
<i>No Action</i>	No action is taken if the process variable input fails.
<i>Man – Hold O/P</i>	Puts the controller into <i>Manual</i> control mode and holds the output at its value immediately prior to the PV failure.
<i>Man – Default O/P</i>	Puts the controller into <i>Manual</i> control mode and sets the output to the default output value.
<b>Default Output</b>	This parameter is used in conjunction with <i>Power Recovery</i> (see page 44) and <i>PV Fail Action</i> settings (see above). For split output this value refers to the <i>PID</i> algorithm (see page 20) before the split range values are calculated.

**...Control / ...Loop 1 (2) Output**

<b>A/M Select Sources</b>	Selection of <i>Auto</i> and <i>Manual</i> control modes can be controlled by digital signals; either from internal digital signals (for example, alarm states) or from external signals via digital inputs (or digital communications).	
<b>Auto Select</b>	The source required to select <i>Auto</i> control mode. Selection is made on the rising edge of the digital signal.	
<b>Manual 1 (2) Select</b>	The source required to select <i>Manual</i> control mode. Selection is made on rising edge of the digital signal. The output value is set according to <i>Manual 1 (2) Output</i> .	
<b>Manual 1 (2) Output</b>	Determines the Manual output value to be set when the controller is put into <i>Manual</i> control mode (see page 5) using <i>Manual 1 (2) Select</i> source.	
<i>Last Auto O/P</i>	Holds the output at its value prior to switching to <i>Manual</i> control mode.	
<i>Man – 0%</i>	Sets the output to 0 %.	
<i>Man – 100%</i>	Sets the output to 100 %.	
<i>Config Value</i>	Sets the output to the value set in <i>Manual 2 Output</i> .	
<b>Manual 1 (2) Config O/P</b>	Used when <i>Manual 1 (2) Output</i> is set to <i>Config Value</i> .	
<b>A/M Toggle</b>	The source required to toggle between <i>Auto</i> and <i>Manual</i> control modes. When the digital signal is high the controller is locked in <i>Manual</i> control mode (front panel keys [see page 5] and other digital select signals have no effect). When the digital signal is low <i>Auto</i> control mode is selected. When in the low state, either the front panel keys (see page 5) or edge-triggered digital signals can be used to put the controller into <i>Manual</i> control mode.	
<b>A/M Output</b>	Sets the manual output value to be set when the controller is put into <i>Manual</i> control mode using <i>A/M Toggle</i> source.	
<i>Last Auto O/P</i>	Holds the output at its value prior to switching to <i>Manual</i> control mode.	
<i>Man – 0%</i>	Sets the output to 0 %.	
<i>Man – 100%</i>	Sets the output to 100 %.	
<i>Config Value</i>	Sets the output to the value set in <i>A/M Config O/P</i> .	
<b>A/M Config O/P</b>	Used when <i>A/M Output</i> is set to <i>Config Value</i> .	
<b>Slew Rate</b>	The output slew rate – restricts the maximum rate of change of the control output.	
<b>Function</b>	Selects if the output slew rate function is enabled and when it applies.	
<i>Off</i>		
<i>Up and Down</i>	The <i>Slew Rate</i> applies to increasing and decreasing output values.	
<i>Up</i>	The <i>Slew Rate</i> applies to increasing output values only.	
<i>Down</i>	The <i>Slew Rate</i> applies to decreasing output values only.	

...Control /...Loop 1 (2) Output / ...Slew Rate

<b>Rate</b>	The maximum rate of change of the control output (% / s).	
<b>Disable Source</b>	The source required to disable slew rate control of the output. This source is level-triggered.	
<b>Tracking</b>	<p>Enables the control output to be configured to follow a tracking signal when in <i>Auto</i> control mode. When in <i>Manual</i> control mode the output can be adjusted by the user as normal. If the slew rate function is enabled, switching from <i>Manual</i> to <i>Auto</i> is bumpless. If the value set by the tracking signal is different to that set manually, the output ramps to its expected auto value at the speed set in the slew rate.</p> <p>If the <i>Signal Source</i> is set to <i>None</i> tracking is disabled and the normal <i>PID</i> output is provided as the control output.</p>	
<b>Source</b>	Sets the source of the signal required to be tracked by the output in <i>Auto</i> control mode. If set to <i>None</i> , output tracking is disabled.	
<b>Signal Source</b>		
<b>Mode</b>	Selects the type of output tracking.	
<i>In Auto</i>	Control output = tracking signal when in <i>Auto</i> control mode.	
<i>Auto + OP</i>	Control output = tracking signal + change in <i>PID</i> output, when in <i>Auto</i> control mode.	
<i>When Enabled</i>	When enable source is active, Control output = tracking signal when in <i>Auto</i> control mode.	
<i>When Enabled + OP</i>	When enable source is active, Control output = tracking signal + change in <i>PID</i> output, when in <i>Auto</i> control mode.	
<b>Enable Source</b>	Sets the digital signal to enable output tracking.	
	<b>Note.</b> Applicable only if <i>Mode</i> is <i>When Enabled</i> or <i>When Enabled + OP</i> .	
<b>Loop 1 (2) Split O/P*</b>	<p>This facility enables the <i>PID</i> control output (see page 20) to be split into 2 separate outputs. This enables heat / cool and other applications requiring dual outputs to be controlled. The linear relationship between the input from the <i>PID</i> algorithm and the 2 outputs is configured using the <i>Min/Max Input/Output</i> parameters (below).</p> <p>When operating with <i>Split O/P</i> in <i>Manual</i> control mode, manual adjustment is made to the input at the split output block (x axis). By default, the <i>Operator</i> page displays both output values (OP1 and OP2).</p>	<p>Min. Input 1 = 0              Min. Output 1 = 100              Max. Input 1 = 50              Min. Output 1 = 0</p> <p>Min. Input 2 = 50              Min. Output 2 = 0              Max. Input 2 = 100              Max. Output 2 = 100</p> <p>Min. Input 1 = 0              Min. Output 1 = 0              Max. Input 1 = 50              Min. Output 1 = 100</p> <p>Min. Input 2 = 50              Min. Output 2 = 0              Max. Input 2 = 100              Max. Output 2 = 100</p> <p>PID Output (%)</p> <p>■ Output 1 (OP1)              ■ Output 2 (OP2)</p>
<b>Loop 1 (2) Valve</b>	See <i>Basic</i> level, page 18.	
<b>Loop 1 (2) Time Prop</b>	See <i>Basic</i> level, page 18.	

\*Applicable only if the output type selected is *Split O/P* – see page 24





...Process Alarm

Alarm 1 (8)	
Type	Alarm types comprise: <i>High Process, Low Process, High Latch, Low Latch</i> . (Deviation alarms are configured using a high or low process alarm and selecting <i>Deviation</i> as the source.)
Tag	The alarm <i>Tag</i> is displayed as a diagnostic message and appears in the <i>Diagnostic Status Bar</i> and the Diagnostic view in the <i>Operator Level</i> .
Source	The analog source – see Appendix A, page 79 for description of sources.
Trip	Alarm trip level in engineering units.
Hysteresis	Hysteresis trip level in engineering units. Activated at the alarm trip level but deactivated only when the process variable has moved into the safe region by an amount equal to the hysteresis value – see <i>Process Alarm</i> examples on page 47.
Time Hysteresis	If an alarm trip value is exceeded, the alarm does not become active until the <i>Time Hysteresis</i> value has expired. If the signal goes out of the alarm condition before the <i>Time Hysteresis</i> has expired, the hysteresis timer is reset.
Display Enable	Enables an alarm to be used for control purposes without it appearing as an active alarm state in the <i>Operator</i> level or <i>Diagnostic</i> views.
Acknowledge Source	The source required to acknowledge all active alarms. Acknowledge occurs on rising edge of the digital signal – see Appendix A, page 79 for description of sources.
Enable Source	The source required to enable alarms. If <i>the</i> source is <i>None</i> , alarms are always enabled – see see Appendix A, page 79 for description of sources.



## 7.6 Totalizer

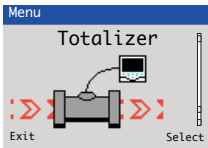

Two 9-digit totalizers are provided. These can be configured independently to totalize any analog or digital signal. Four modes of operation are provided.

Where possible, the count rate is calculated automatically according to source units, totalizer units and engineering range.

### Totalizer 1 (2)

#### Mode

- Off** Totalizer disabled.
- Analog** Totalization of any analog signal.
- Digital** Counting of low / high transitions of any digital signal (for example, digital input or alarm) minimum pulse duration >125 ms.
- Frequency** Totalization of a frequency input on Analog input 1.
- Pulse** Totalization of a pulse input on Analog input 1.

#### Source

The input to be totalized. The inputs available for selection are dependent on the selected *Mode*. Not displayed for frequency and pulse inputs – see Appendix A, page 79 for description of sources.

#### Count Direction

- Up** Totalizer value increases with time.
- Down** Totalizer value decreases with time.

#### Units

(Totalizer) units are used along with the source's units and engineering range to calculate the count rate automatically (where possible). Where the units or mode required do not allow this, the count rate must be calculated manually – see Section 7.6.1, page 51.

#### Count Rate

In *Analog* mode, this represents the counts (in volume units) / second when the source is at its engineering high value.  
 In *Digital*, *Frequency* and *Pulse* mode, this represents the number of totalizer (volume) units / pulse.

#### Cutoff

The lowest input value (in engineering units) at which the totalizer stops counting.

#### Stop Go Source

The source required to stop and start the totalizer. Selection is made on the rising edge.



...Totalizer

Total DP's	Selects the number of decimal places displayed on the totalizer value.
Preset Count	The value the totalizer counts from and the value applied when the totalizer is reset.
Predet Count	The value at which the totalizer stops or wraps.
Intermed'te Count	The value at which the intermediate count digital signal is activated. This can be used as an alarm threshold to indicate when the <i>Predet Count</i> value is about to be reached.
Wrap Enable	If set to <i>On</i> , the total is reset automatically to the <i>Preset Count</i> value once the <i>Predet Count</i> value is reached. The wrap <i>Digital</i> signal is activated for 1 second. If set to <i>Off</i> the count stops when the <i>Predet Count</i> value is reached. The wrap <i>Digital</i> signal is activated until the totalizer is reset.
Reset Source	The source required to reset the totalizer value. Selection is made on the rising edge.  <p>The diagram shows a horizontal line representing a signal. A vertical arrow points upwards from the line, labeled 'Reset', indicating the rising edge of the signal.</p>
Reset Days	Selects the day or days to reset the totalizer.
Reset Hour	Selects the hour to reset the totalizer (the totalizer is always reset exactly on the hour).

### 7.6.1 Calculating the Totalizer Count Rate Manually

#### Analog Mode

$$\text{Count Rate} = \frac{\text{Eng Hi (of source)} \times \text{volume unit conversion}}{\text{time unit conversion}}$$

Example:

Eng Hi = 2500 l/m. Totalizer required to increment in m<sup>3</sup>.

Volume unit conversion: 1 l = 0.001 m<sup>3</sup>.

Source time units = minutes, count rate units = seconds.

Time unit conversion: 1 min = 60 s.

$$\text{Count Rate} = \frac{2500 \times 0.001}{60} = 0.04167 \text{ m}^3/\text{s}$$

If the input source is at a fixed rate of 2500 l/min, the totalizer increments at 0.04167 m<sup>3</sup>/s.

If the input source is reduced to a fixed rate of 1250 l/min, the totalizer increments at:

$$\frac{1250}{2500} \times 0.04167 = 0.0208 \text{ m}^3/\text{s}$$

#### Digital Mode

The count rate setting determines the scaling of the digital input pulses.

For example, with a Count Rate = 100 totalizer units / pulse, 5 digital input pulses increment the totalizer from 0 to 500 in 100 unit steps:

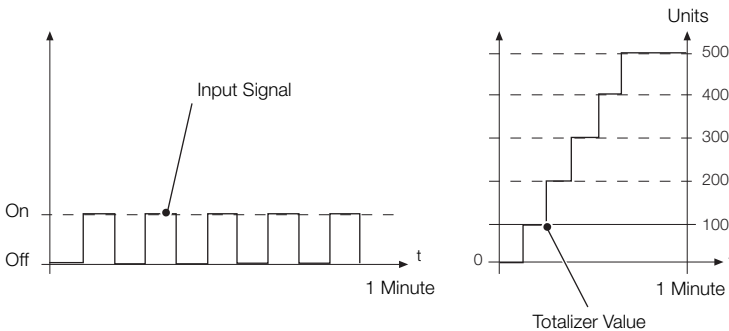

### Frequency Mode

$$\text{Count Rate} = \frac{\text{Eng Hi (of source)} \times \text{volume unit conversion} \times \text{pulse duration}}{\text{time unit conversion}}$$

Example:

Eng Hi = 6000 l/m. Frequency input fullscale (Electrical High) = 500 Hz,

Totalizer required to increment in m<sup>3</sup>.

Volume unit conversion: 1 l = 0.001 m<sup>3</sup>.

Source time units = minutes, count rate units = seconds.

Time unit conversion: 1 min = 60 s

$$\text{Pulse Duration} = \frac{1}{\text{Analog input 1 Electrical High (Hz)}}$$

$$\text{Count Rate} = \frac{6000 \times 0.001 \times 0.002}{60} = 0.0002 \text{ m}^3/\text{s}$$

if the input source is at a fixed rate of 6000 l/min (500 Hz) the totalizer increments at 0.0002 m<sup>3</sup>/s.

If the input source is reduced to a fixed rate of 3000 l/min (250 Hz), the totalizer increments at:

$$\frac{3000}{6000} \times 0.0002 = 0.0001 \text{ m}^3.$$

### Pulse Mode

$$\text{Count Rate} = \frac{\text{Volume unit conversion}}{\text{Pulse / Unit}}$$

Example:

Pulse / Unit = 50, Pulse Units = l, Totalizer required to increment in m<sup>3</sup>.

Volume unit conversion: 1 l = 0.001 m<sup>3</sup>.

$$\text{Count Rate} = \frac{0.001}{50} = 0.00002 \text{ m}^3/\text{pulse}$$

## 7.7 Functions

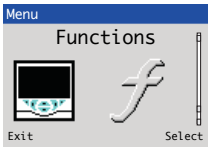

Contains parameters for setting up the math block(s), logic equations and timer functions within the controller.

### Logic Equations

Up to 8 logic equations can be configured. Each equation can combine a maximum of 8 operands (digital signals) with 7 operators.

The elements of each equation are calculated sequentially. Operand 1, Operator 1 and Operand 2 are evaluated first and the result is combined with Operator 2 and Operand 3. This result is then combined with the next operator and operand and so on to the end of the equation.

Setting an operator to *END* terminates the equation.

**Note.** 2 Logic equations are required to perform an exclusive *OR* of 3 inputs.

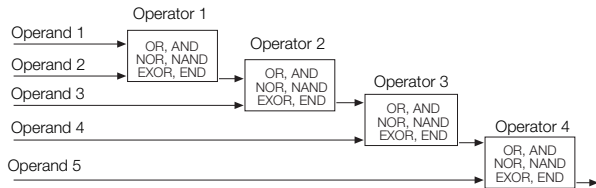

**Key:**

OR	Output is 1 if either or both inputs are 1; output is 0 if both inputs are 0
AND	Output is 1 if both inputs are 1; output is 0 if either input is 0
NOR	Output is 0 if either or both inputs are 1; output is 1 if both inputs are 0
NAND	Output is 0 if both inputs are 1; output is 1 if either input is 0
EXOR	Output is 0 if both inputs are 0 or both inputs are 1; output is 1 if one input is 1 and the other is 0
END	Terminates the equation

**Note.** If any of the operand sources are invalid (for example, an alarm that is not configured), the logic equation output state is zero and invalid.

Equation Number	Selects the logic equation (1 to 8) to be configured.
Operand 1 (8)	See Appendix A, page 79 for description of sources.
Invert 1 (8)	Logically inverts (applies <i>NOT</i> function to) the digital signal. For example, if the digital signal assigned to the operand has a state of '1' it is inverted to a state of '0' before being applied to the equation.
Operator1 (7)	Selects the operator type ( <i>OR</i> , <i>AND</i> , <i>NOR</i> , <i>NAND</i> , <i>EXOR</i> ). Select <i>END</i> if no more elements are required.

...Functions

<b>Math Blocks</b>	Up to 8 math blocks can be configured. Each block can be configured as one of 6 different types (see <i>Block Type</i> below). The resulting analog value can be used as a source for other function blocks, for example, <i>Process Variable</i> in the <i>Custom Config</i> parameter – see page 25.												
<b>Math Block Number</b>	The math block number (1 to 8).												
<b>Block Type</b>	Selects the type of math block required.												
<b>Equation</b>	(See page 55 for <i>Equation</i> setup.) Enables an equation with up to 4 operands and 3 operators to be created. The operands can be assigned to any analog or digital signal (see page 79). Digital signals have a value of either '0' or '1'. With the exception of the Median operator, the equation is processed in a strict left to right order, with no operator precedence.  The result of a math block can be used as the operand in another math block, enabling more complex math equations to be constructed. The math blocks are processed in ascending order; <i>Math Block 1</i> is processed first, then <i>Math Block 2</i> , then 3 to 8.												
<b>Real Time Average</b>	(See page 55 for <i>Real Time Average</i> setup.) Calculates the average value of a parameter over a user-configurable duration. The output of the math block is updated at the end of the set duration only. A reset signal can be configured to restart the calculation of the average value.  The average value is stored in case of power failure. If the duration of the power failure is longer than the <i>Average Duration</i> (see page 55), the math block output value is set to zero.												
<b>Max Hold Min Hold</b>	(See page 55 for <i>Max Hold / Min Hold</i> setup.) The math block output represents the highest / lowest value of the signal since it was reset.												
<b>Multiplexer</b>	(See page 56 for <i>Multiplexer</i> setup.) Enables 1 of 2 analog signals or constant values to be selected using a digital signal.  <table border="1" style="display: inline-table; vertical-align: middle;"> <thead> <tr> <th colspan="2"></th> <th colspan="2">Select</th> </tr> <tr> <th colspan="2"></th> <th>0</th> <th>1</th> </tr> </thead> <tbody> <tr> <th>O/P</th> <th></th> <td>A</td> <td>B</td> </tr> </tbody> </table>			Select				0	1	O/P		A	B
		Select											
		0	1										
O/P		A	B										
<b>Square Root</b>	(See page 56 for <i>Square Root</i> setup.) Calculates the square root of the selected sources value. If the input is less than 0, the output is set to zero and the math block output state set to invalid.												



...Functions / ...Math Blocks

**Equation Setup**

Source 1 (2)	The source of the first operand in the equation (any analog or digital signal or user-defined constant).
Source 1 (2) Constant	Sets the constant value to be used. <b>Note.</b> Applicable only if <i>Source 1</i> is assigned to one of the constants.
Operator 1 (3)	
<i>End</i>	Terminates the equation.
<i>Add</i>	} Standard arithmetic functions.
<i>Subtract</i>	
<i>Multiply</i>	
<i>Divide</i>	
<i>Low Select</i>	
<i>High Select</i>	Result is the higher of the 2 operands.
<i>Median</i>	If <i>Median</i> operators are used the median value calculated is dependent on the number of operands: <ul style="list-style-type: none"> <li>■ The median value of 2 operands is their mean value.</li> <li>■ The median value of 3 operands is the value of the middle operand when the operands are sorted in ascending order.</li> <li>■ The median value of 4 operands is the mean value of the 2<sup>nd</sup> and 3<sup>rd</sup> operands when the 4 operands are sorted in ascending order.</li> </ul>

**Real Time Average Setup**

Source 1	Selects the source for real time average value calculation – see Appendix A, page 79 for description of sources.
Reset Source	Selects the digital source required to reset the internal accumulative value and timer. This does not change the immediate output of the math block but restarts the calculation of the next average value.
Average Duration	Sets the time duration the average is to be calculated over. The output value of the math block is updated at this rate.

**Max Hold / Min Hold Setup**

Source 1	Selects the source for maximum / minimum value calculation – see Appendix A, page 79 for description of sources.
Reset Source	Select the digital signal to be used to reset the maximum or minimum value.

...Functions / ...Math Blocks

**Multiplexer Setup**

Source 1	Selects the source for the first input into the multiplexer.
Source 1 Constant	Sets the constant value to be used. <b>Note.</b> Applicable only if <i>Source 1</i> is assigned to one of the constants.
Source 2	Select the source for the second input into the multiplexer.
Source 2 Constant	Sets the constant value to be used. <b>Note.</b> Applicable only if <i>Source 1</i> is assigned to one of the constants.
Mux Selector	Select the digital signal to be used to switch between the 2 multiplexer inputs. '0' selects first input ( <i>Mux A Src</i> ); '1' selects second input ( <i>Mux B Src</i> ).

**Square Root Setup**

Source 1	Selects the source of the parameter that requires square root to be applied.
----------	--

Setup for **All Math Block Types**

Eng. Dps	Selects the number of decimal places (resolution) displayed for the math block result.
Eng. Low Eng. High	Selects the engineering range low / high value for display purposes and for calculation of the proportional band. If the math block result exceeds the <i>Eng High</i> or <i>Eng Low</i> value by more than 10 %, a math block fail state is set and its output is determined by the <i>Fault Action</i> – see below.
Eng Units	The selected units are displayed in the operator pages – see Appendix C, page 83 for description of engineering units.
Fault Action	The value returned when the math block fails can be configured.
None	Failed calculated value is used as math block output.
Automatic	If the failed calculated output value is below zero the output is driven to the minimum value. If the failed calculated output value is above zero the output is driven to the maximum value.
Upscale	If the math block fails, the output is driven to the maximum value.
Downscale	If the math block fails, the output is driven to the minimum value.

...Functions

<p><b>Linearizer 1 (2)</b></p>	<p>A custom 20-breakpoint linearizer. Custom linearizers can be applied to any analog input by selecting them as the linearizer type for that input – see page 32.</p> <p>The engineering range and units of the input source are assigned to the custom linearizer output.</p>	
<p><b>Source 1 (2)</b></p>	<p>Selects the input source to be linearized – see Appendix A, page 79 for description of sources.</p>	
<p><b>Lin 1 (2)</b>  <b>Breakpoints</b></p> <p><i>Breakpoint</i></p> <p>X</p> <p>Y</p>	<p>Selects the breakpoint to be configured.</p> <p>X is input to the linearizer expressed as a % of the electrical range.</p> <p>Y is output expressed as a % of the engineering range.</p> <p>Once configured, a custom linearizer must be soft-wired to an input or output using the custom template feature – see Section 7.1, page 24.</p>	
<p><b>Delay Timer 1 (2)</b></p>	<p>2 Delay timers are provided. The delay timer is triggered by the rising edge of its assigned source. An internal timer is started and, when the timer reaches the set <i>Delay Time</i>, its output goes high for the <i>On Time</i> that is configured. After the delay time is triggered it ignores any further transitions of the source input until the end of this delay timer cycle (until the end of the <i>On Time</i>).</p>	
<p><b>Source 1 (2)</b></p>	<p>The source signal used to trigger the delay timer. Trigger occurs on rising edge of the signal – see Appendix A, page 79 for description of sources.</p>	
<p><b>Delay Time</b></p>	<p>The delay (in seconds) between the trigger received and the output of the delay timer going high.</p>	
<p><b>On Time</b></p>	<p>The length of time in seconds the delay timer output is held in the high state.</p>	

...Functions

<b>Real Time Alarms</b>	2 Independent real-time alarms can be configured to be activated on particular days and times for a set duration.
<b>Real Time Alarm 1 (2)</b>	Sets the days the alarm is activated, the alarm duration, alarm display enable in the diagnostics window and enables a (status bar) tag to be created for the alarm.
<i>Monday (to Sunday)</i>	
<i>Month enable</i>	When enabled ( <i>On</i> ), activates the alarm on the 1 <sup>st</sup> day of each month.
<i>Every hour</i>	When enabled ( <i>On</i> ), activates the alarm every hour.
<i>On hour</i>	Sets the hour the alarm is activated – not applicable if <i>Every Hour</i> is set to <i>On</i> .
<i>On minute</i>	Set the minutes past the hour the alarm is activated.
<i>Duration</i>	Set the duration the alarm is active.
<i>Display enable</i>	If disabled ( <i>Off</i> ), the alarm state does not appear in the operator level diagnostics window or the alarm log.
<i>Tag</i>	A 16-character alphanumeric tag displayed as a diagnostic message that appears in the <i>Diagnostic Status Bar</i> and in the <i>Operator Level, Diagnostic View</i> – see page 16.

## 7.8 Communication

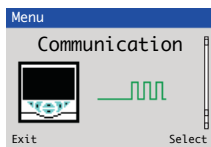

Used to setup communications parameters for the (optional) MODBUS / Ethernet communication protocols – see separate User Guide (IM/CM/C-EN).

**Note.** Only one communications option can be fitted per controller.

## 7.9 Diagnostics

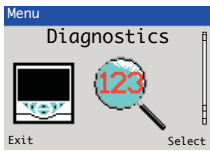

Used to view diagnostic and performance (historical) data – see Section 7.9.1 for description of diagnostic messages and recommended corrective action(s).

**Diagnostic History** Displays a log of the diagnostic messages generated by the controller. Each diagnostic condition has a classification code conforming to NAMUR NE107.

$n$  = Number of instances of this diagnostic condition

$\Sigma$  = Total time spent in this diagnostic condition

$t_n$  = Time since the last instance of this diagnostic condition

Configuration

-- C178.025

In Configuration

n : 2

$\Sigma$  : 00h 04m 07s

In : 01h 03 m 15s

M = Maintenance

S = Out of Spec

C = Check Function

F = Failure

178.025

Diagnostic priority  
Highest value = 250

Internal Code

**Source Analysis**

<b>Analog Sources</b>	Enables the current value of any analog source to be viewed.
<b>Analog Source</b>	Selects the analog signal to be viewed – see Section 7.9.1, page 60.
<b>View Value</b>	Displays the value of the analog signal selected.
<b>Digital Sources</b>	Enables the current state of any digital source to be viewed.
<b>Digital Source</b>	Selects the digital signal to be viewed – see Appendix A.1 on page 79.
<b>View State</b>	Displays the state of the digital signal selected.
<b>Invalid Sources</b>	Select edit to display any invalid analog or digital sources that are used in the configuration.

Reasons for invalid sources include:

- Hardware not fitted
- Software not fitted
- Digital I/O configured as wrong type
- Alarms not configured
- Math, logic, timer or custom linearizer not configured

### 7.9.1 Diagnostic Messages

Icon	Number / Message	Possible Cause	Suggested Action
⊗	242.004 ADC 1 Failed	Temporary or permanent failure of analog to digital converter on the main I/O board.	Cycle power to device. If problem persists replace main I/O board, contact local service organization.
⊗	240.005 ADC 2 Failed	Temporary or permanent failure of analog to digital converter on the option board.	Cycle power to device. If problem persists replace option board, contact local service organization.
⊗	250.000 (248.001) PV 1 (2) Failed	Problem with Input assigned to Loop 1 (2) PV. Broken sensor leads, defective input source or input signal out of permitted range.	Check wiring. Check input source. Check if input signal is outside permitted limits.
⊗	246.002 (244.003) RSP 1 (2) Failed	Problem with Input assigned to Loop 1 (2) Remote Setpoint. Broken sensor leads, defective input source or input signal out of permitted range.	Check wiring. Check input source. Check if input signal is outside permitted limits.
⊗	222.014 (220.015) CJ 1 (2) Failed	Error in Cold junction measurement associated with AIN1 (AIN3). Wiring fault or defective sensor.	Check cold junction device is correctly fitted. Ensure I/P 2(4) is turned off. Replace CJ sensor.
⊗	226.012 (224.013) DV 1 (2) Failed	Problem with input assigned to Loop 1 (2) disturbance variable. Broken sensor leads, defective input source or input signal out of permitted range.	Check wiring. Check input source. Check if input signal is outside permitted limits.
⊗	230.010 (228.011) WV 1 (2) Failed	Problem with input assigned to Loop 1 (2) wild variable. Broken sensor leads, defective input source or input signal out of permitted range.	Check wiring. Check input source. Check if input signal is outside permitted limits.
⊗	234.008 (232.009) PFB 1 (2) Failed	Problem with input assigned to Loop 1 (2) position feedback. Broken sensor leads, defective input source or input signal out of permitted range.	Check wiring. Check input source. Check if input signal is outside permitted limits.
⊗	216.016 NV Error Proc Bd	Failure of non-volatile memory on processor / display board or permanent corruption of its data.	Check all configuration parameters and correct any errors. Acknowledge error. If problem persists contact local service organization.
⊗	214.017 NV Error Main Bd	Failure of non-volatile memory on main board or permanent corruption of its data.	Check calibration of AIN1, AIN2 and AO1. Recalibrate if necessary. Acknowledge error. If problem persists contact local service organization.

Table 7.1 Diagnostic Messages

Icon	Number / Message	Possible Cause	Suggested Action
⊗	212.018 NV Error Opt Bd 1	Failure of non-volatile memory on option board 1 or permanent corruption of its data.	Check calibration of AO2, AIN 3 and AIN4 (CM50 only). Recalibrate if necessary. Acknowledge error. If problem persists contact local service organization.
⊗	210.019 NV Error Opt Bd 2	Failure of non-volatile memory on option board 2 or permanent corruption of its data.	Check calibration of AO2, AIN 3 and AIN4. Recalibrate if necessary. Acknowledge error. If problem persists contact local service organization.
⊗	208.020 NV Error Comm Bd	Failure of non-volatile memory on communications board or permanent corruption of its data.	Acknowledge error. Check communications board is correctly identified by device. If problem persists contact local service organization.
⊗	206.021 NV Error SW Key 1	Failure of non-volatile memory on Software key 1 or permanent corruption of its data.	Acknowledge error. Check software key functionality is enabled. If problem persists contact local service organization.
⊗	204.022 NV Error SW Key 2	Failure of non-volatile memory on Software key 2 or permanent corruption of its data.	Acknowledge error. Check software key functionality is enabled. If problem persists contact local service organization.
⊗	202.023 NV Error SW Key 3	Failure of non-volatile memory on Software key 3 or permanent corruption of its data.	Acknowledge error. Check software key functionality is enabled. If problem persists contact local service organization.
⊗	Config Error	The configuration contains a source that is no longer present or valid.	Check invalid sources in diagnostics menu – see Section 7.9, page 59. Check configuration, check I/O required for configuration is present and correct any illegal use of the invalid signal by changing configuration or fitting additional option cards.
⚠	054.044 (052.045) Tune Lp1 (2) Fail	Autotune has failed to complete its sequence or has calculated values outside of its permitted range.	Check process response. Consider if Autotune dynamic setting should be changed. Ensure process is stable and repeat autotune. If problem persists tune the loop manually.
⚠	062.042 (058.043) Tune Lp1 (2) Noise	Autotune has failed due to excessive process or measurement noise.	Check input wiring. Ensure process is stable and repeat Autotune. If problem persists, tune the loop manually.

Table 7.1 Diagnostic Messages (Continued)

Icon	Number / Message	Possible Cause	Suggested Action
	070.040 (066.041) Tuner 1 (2) Abort	Autotune has been aborted by the user.	
	078.038 (074.039) Adaptive 1 (2) Warn	Parameters calculated by adaptive control have changed by more than the permitted amounts.	Check process for issues that may have caused a large change in its dynamics, for example, a blocked valve. Reset adaptive control. Perform a fresh autotune.
	086.036 (082.037) Oscillation 1 (2)	Abnormal oscillations in the control loop.	Check process. Perform new manual or Autotune.
	094.034 (090.035) Valve 1 (2) Sticking	Motorized valve travel time is significantly slower than configured time.	Check valve to identify reason for sticking. Check correct travel time is entered in configuration.
	168.026 (166.027) (164.028) Tuner 1 Phase 1..3	Autotune is in progress. See page 19 for details of each phase.	Autotune can be aborted if required by selecting <i>Manual</i> control mode.
	160.030 (158.031) 156.032 Tuner 2 Phase 1..3	Autotune is in progress. See page 19 for details of each phase.	Autotune can be aborted if required by selecting <i>Manual</i> control mode.
	162.029 (154.033) Tuner 1 (2) Pass	Autotune has completed successfully and calculated new control parameters.	Acknowledge diagnostic message.
	178.025 In Configuration	The device is currently in the configuration mode.	This is for use with remote access via digital communications.

Table 7.1 Diagnostic Messages (Continued)



## 7.10 Device Info

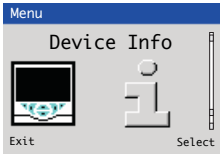

Used to display read-only factory-set parameters for the controller.

<b>Instrument Type</b>	The controller's model number (for example, CM30).
<b>I/O Build</b>	The input / output (I/O) configuration.
<b>No. Analog Inputs</b>	The number of analog inputs available.
<b>No. Analog Outputs</b>	The number of analog outputs available.
<b>No. Relays</b>	The number of relays available.
<b>No. Digital I/O</b>	The number of digital inputs / outputs available.
<b>Functionality</b>	The current functional setting of the controller (for example, <i>Dual Loop</i> ).
<b>Serial No.</b>	The factory serial number.
<b>Hardware Revision</b>	The controller's hardware version number.
<b>Software Revision</b>	The controller's software version number.

## 8 Templates and Functionality

### Notes.

- Input assignments can be changed in *Device Setup / Custom Config* – see page 25.
- Output assignments can be changed in *Input / Output* configuration – see page 32.

### 8.1 Basic Templates

#### 8.1.1 Single Loop / Single Loop with Remote Setpoint

This template provides basic feedback control using three-term PID or On/Off control. The controller output is calculated from the difference between the process variable and the control setpoint. The control setpoint can be a fixed value entered by the user (Local setpoint) or an input from a remote source (remote setpoint).

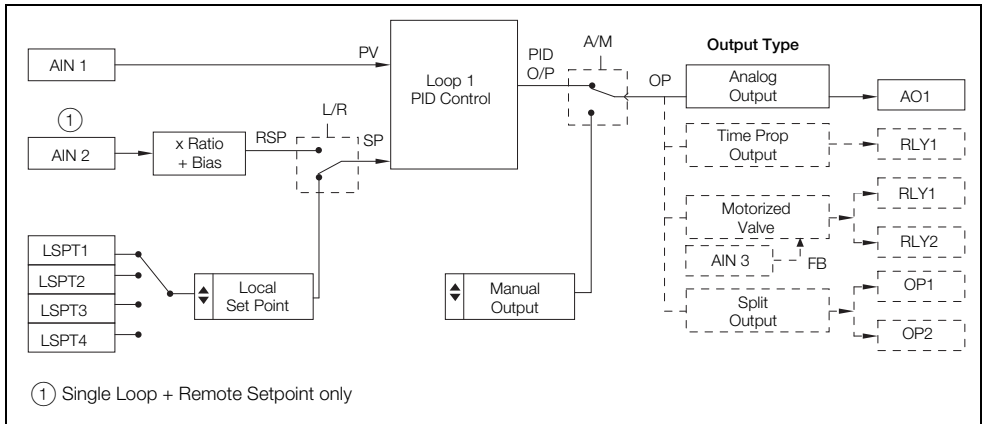

## 8.2 Standard Templates

### 8.2.1 Auto / Manual Station (Low Signal Selection / Digital Signal Selection)

This template configures the ControlMaster as a back up for a Master Controller (system). In normal operation the ControlMaster's current output follows the master controllers output value in Automatic mode. Upon detection of a fault in the Master system, which is identified by either a low signal value on the Master Output or via a digital Input signal, the ControlMaster selects Manual Mode with either the last valid Master Output value or a pre-configured fixed output value. Once the Master signal is restored or the digital input state returns to its normal state the ControlMaster switches back to Auto Mode and continues to follow the Master Controller output.

(See Fig. 8.1, page 67 for details of parallel connection).

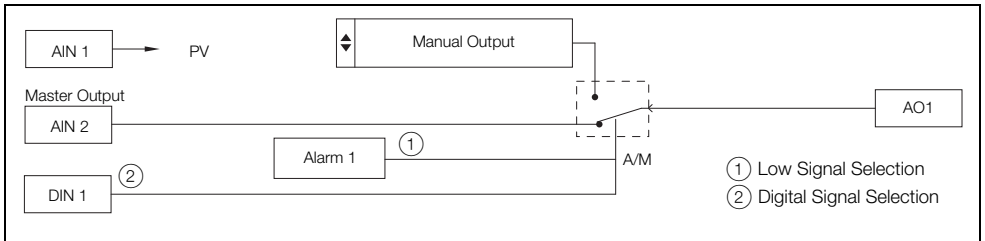

### 8.2.2 Analog Backup Station (Low Signal Selection / Digital Signal Selection)

This template provides a back up for a master controller (system). In normal operating mode, the ControlMaster operates in Remote Control Mode. In this mode the output of the ControlMaster follows the Master controller's output. If a fault is detected in the Master system, either by a low signal on the Master output or by a digital input, the ControlMaster switches into Local Control Mode and the process is controlled by the PID output of the ControlMaster.

The PID algorithm continuously tracks the Master Controller output value to ensure a bumpless transfer from remote to local operation. Once the Master Controller output is restored or the digital Input returns to its normal state the ControlMaster switches back to Remote Control Mode and continues to track the master Controller.

(See Fig. 8.1, page 67 for details of parallel connection).

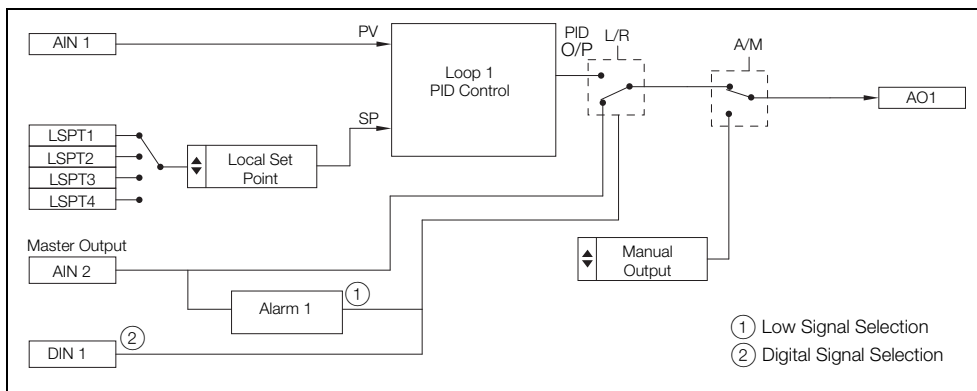

The auto-manual station and analog backup station templates can be used in series or in parallel with the master output signal. Parallel operation is achieved by using an external relay that is triggered by a relay on the ControlMaster, and selects the output to be routed to the process. This setup allows uninterrupted control, even in the event of failure of either the master controller or ControlMaster.

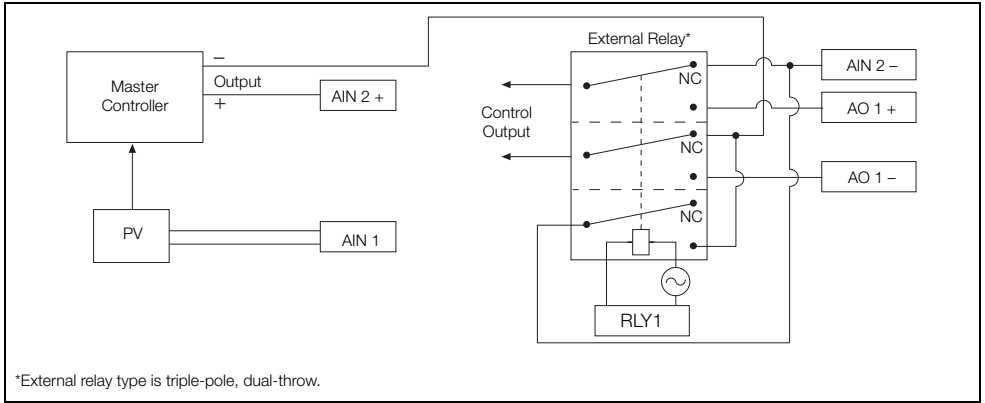
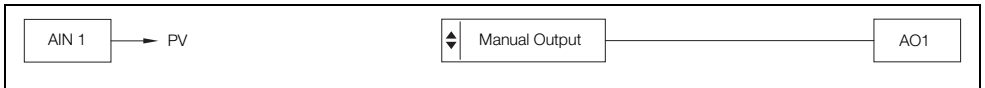

Fig. 8.1 Parallel Connection

### 8.2.3 Single Indicator

The Single Indicator template is used to display one process variable on the digital display.



### 8.2.4 Dual Indicator

The Dual Indicator template is used to display two process variables on the digital display.

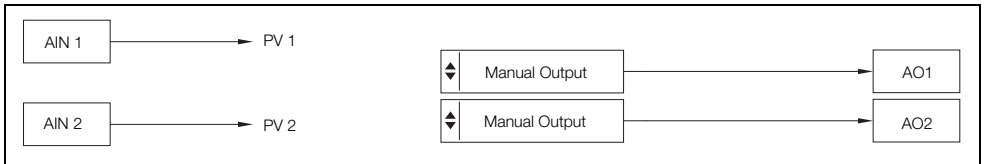

### 8.3 Extended Templates

#### 8.3.1 Feedforward / Feedforward with Remote Setpoints

This template allows for an extra (disturbance) variable which is weighted by the feedforward gain and bias values to be then added to the controller output value. When in manual mode the PID output tracks the difference between the control output value and the feedforward signal to ensure bumpless transfer back in to auto mode.

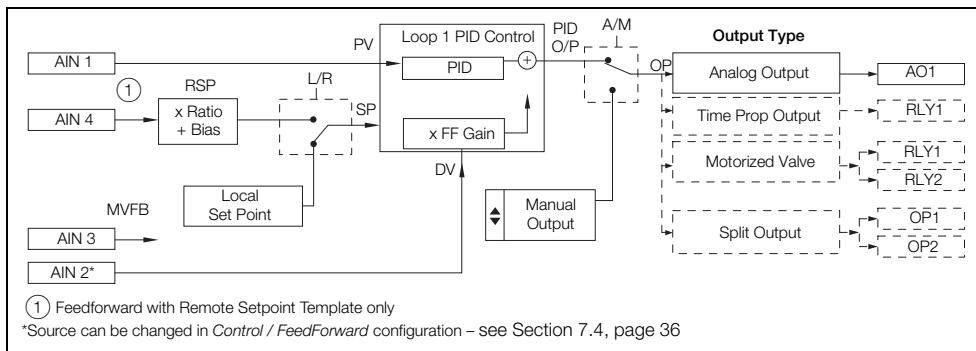

#### 8.3.2 Cascade / Cascade with Remote Setpoints

This template connects 2 PID loops together in order to enhance the control of a Master variable (loop) by manipulation of a slave loop. The first (master) controller provides the set point for the second (slave) Controller. The 2 controllers are linked internally.

The Master output can be weighted using the Cascade ratio and bias values to create the Slave setpoint value. When the auto/manual mode is changed via the front panel or by a digital signal both the master and slave controllers change mode. In manual mode the slave setpoint can be adjusted by the user and the value is tracked by the master controller to ensure bumpless transfer back into auto mode.

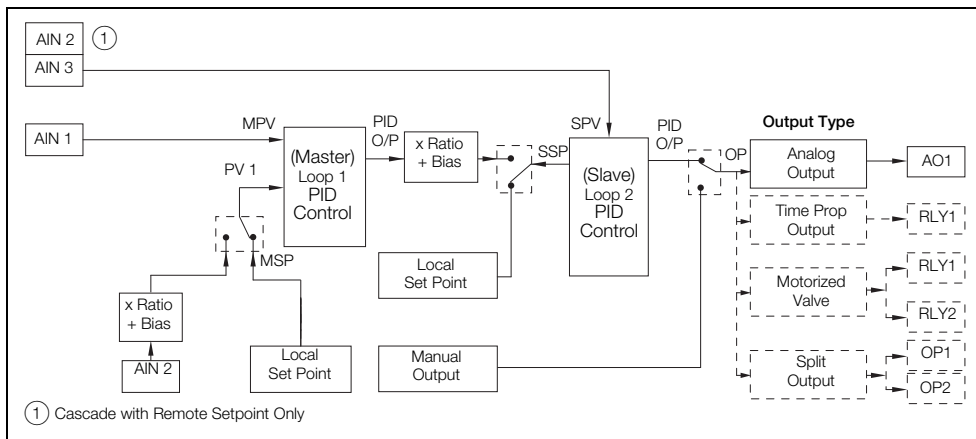

### 8.3.3 Cascade with Feedforward

This template connects 2 PID loops together in order to enhance the control of a Master variable (loop) by manipulation of a slave loop. The first (master) controller provides the set point for the second (slave) Controller. The 2 controllers are linked internally.

To the Master output a feedforward signal is added. This signal is a disturbance variable which is weighted by the feedforward ratio and bias values. When the auto/manual mode is changed via the front panel or by a digital signal both the master and slave controllers change mode, the slave setpoint can then be adjusted from the front panel, and this value is then tracked by the Master controller (taking account of the feedforward signal) to ensure a bumpless transfer back into auto mode.

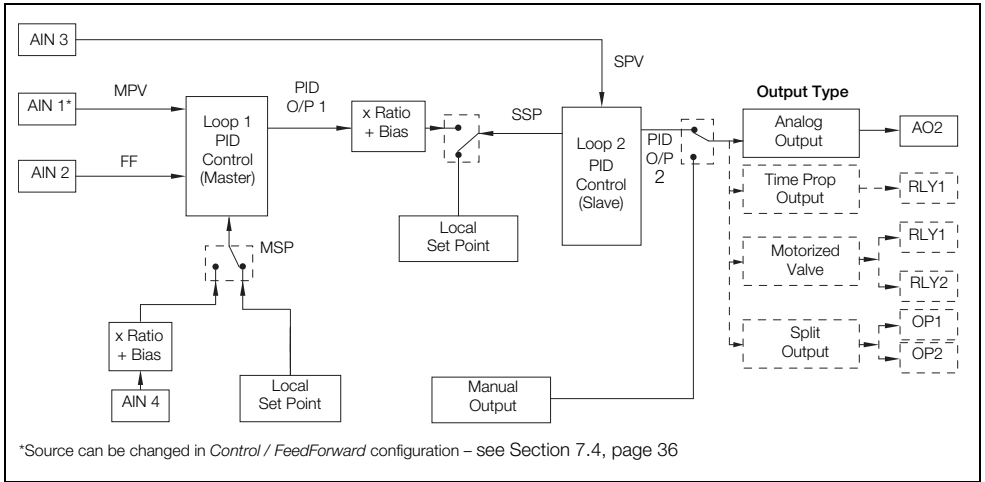

### 8.3.4 Ratio Controller (Internal / External Ratio)

The ratio controller template configures the ControlMaster to regulate one process variable against another based on a specified ratio. The unregulated variable or 'wild' variable is weighted by ratio and bias values and this forms the control setpoint for the process variable. The ratio value applied to the wild variable can either be a local value set on the front panel or a remote signal on an analog input.

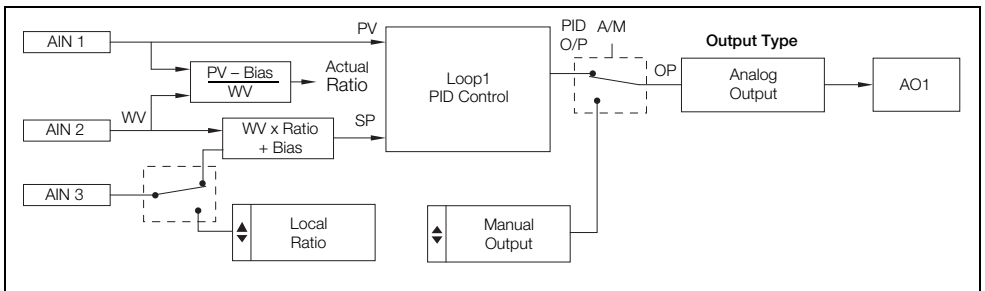

### 8.3.5 Ratio Station (Internal / External Ratio)

The ratio station template configures the ControlMaster as an Indicator and setpoint generator. The unregulated 'wild' variable is weighted with ratio and bias values and is then retransmitted to a slave controller.

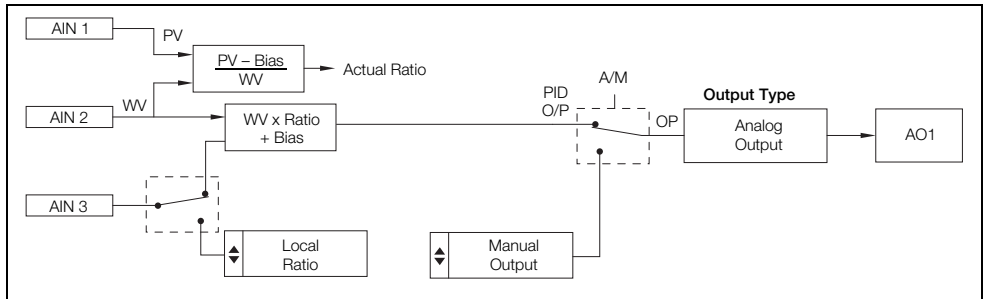



### 8.4 Dual Loop Templates

Dual loop templates allow the ControlMaster to act as 2 independent single loop controllers. These templates are available with remote setpoint for either, or both control loops. This allows the same output options seen on the single loop template.

#### 8.4.1 Dual Loop – Local Setpoint / Local Setpoint

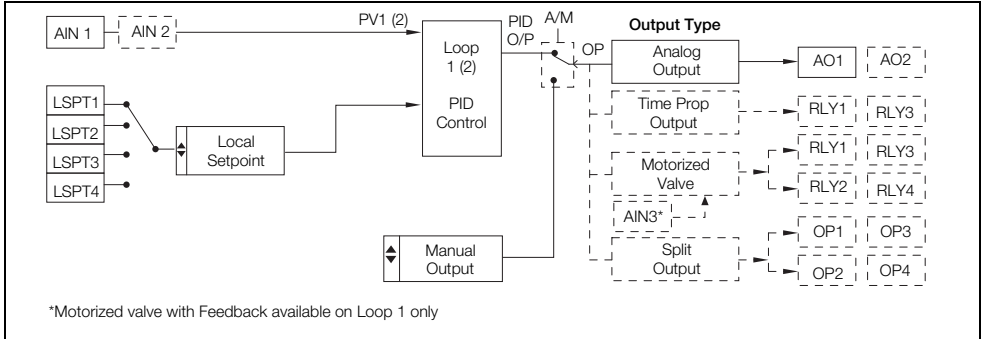

#### 8.4.2 Dual Loop – Remote Setpoint / Local Setpoint

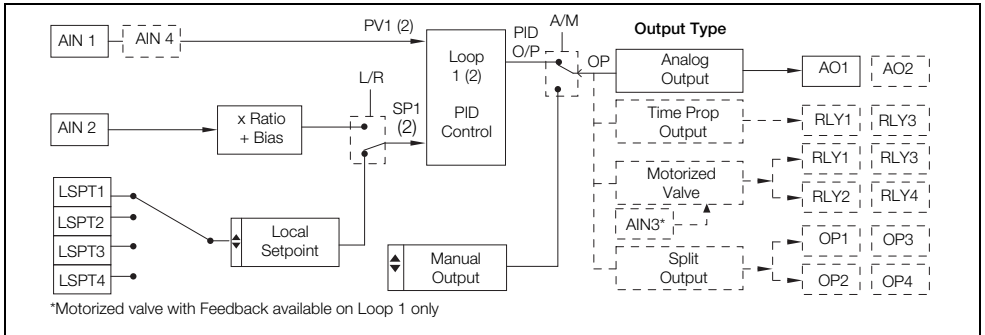

#### 8.4.3 Dual Loop – Remote Setpoint / Remote Setpoint

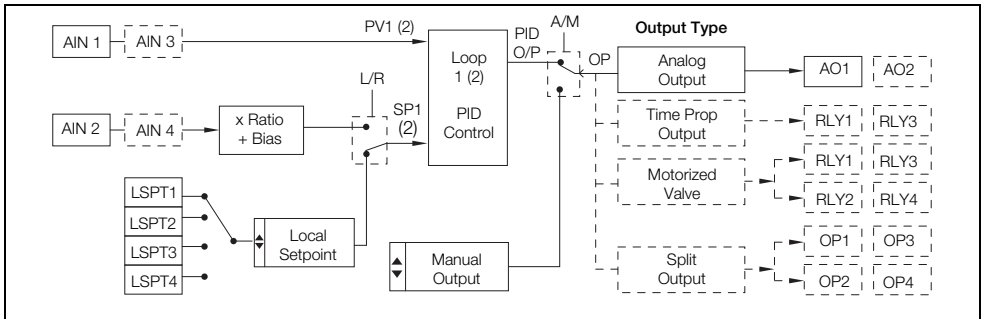

## 9 PC Configuration

In addition to local configuration via the front panel keys, the controller can be configured from a PC via the infrared port. The infrared port is activated when *Advanced* level is accessed. For further information contact your sales representative.

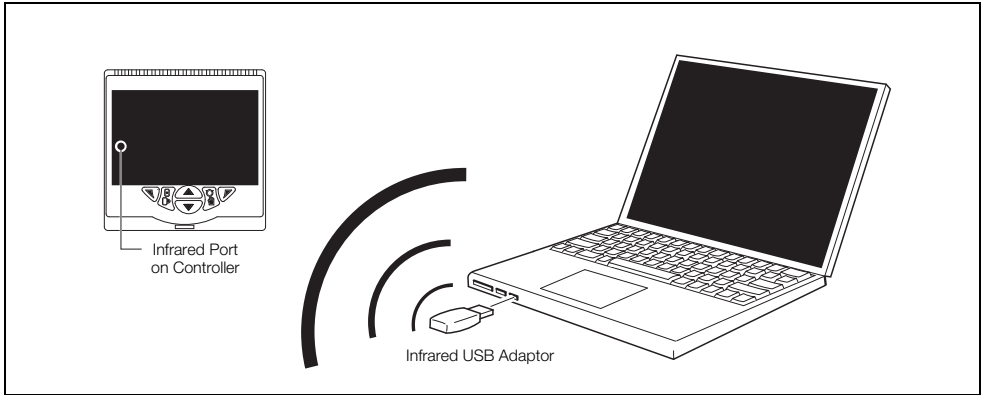

Fig. 9.1 PC Configuration via Infrared Port

## 10 Specification

### Operation

#### Display

Color 1/4 VGA TFT, liquid crystal display (LCD) with built-in backlight

#### Language

English, German, French, Italian and Spanish

#### Operator keypad

6 Tactile membrane keys

#### Trend display

Recording of 2 variables

Configurable sample rate (1 second to 5 minutes)

272 samples displayed on screen

---

### Security

#### Password protection

Basic / Advanced – user-assigned password protection (not set at factory)

---

### Standard functions

#### Control strategies

Basic templates	Single loop with local setpoint Single loop with remote setpoint
Standard templates	Auto/Manual station (low signal detection) Auto/Manual station (digital signal selection) Analog backup station (low signal detection) Analog backup station (digital signal selection) Single indicator / manual loader station Dual indicator / manual loader station
Extended templates	Single loop with feedforward Single loop with feedforward and remote setpoint Cascade Cascade with remote setpoint Cascade with feedforward Ratio controller with internal ratio Ratio controller with external ratio Ratio station with internal ratio Ratio station with external ratio
Dual loop templates	Dual loop with local setpoints Dual loop with remote setpoint on 1 and local setpoint on 2 Dual loop with remote setpoint on both

#### Control output types

Current proportioning

Time proportioning

On / Off

Motorized valve with feedback

Motorized valve without feedback

Split output – with combinations of relay, digital O/P and current O/Ps

#### Control parameters

Proportional band\* 0 to 999.9 s

Integral\* 0 to 10000 s

Derivative\* 0 to 999.9 s

Manual Reset 0.0 to 100 %

\*3 sets of PID parameters when used with Gain Scheduling

#### Setpoints

Local 4 local set points, all selectable via digital inputs or front panel

Remote selectable via digital input or front panel keys

#### Autotune

On-demand calculation of control settings

---

### Process alarms

Number 8

Types High / Low process  
High / Low latch

Source Fully configurable (for example, PV, analog input, math block inbuilt, OP control loop deviation)

Hysteresis Level and time

Alarm enable Enable / Disable of individual alarms via a digital signal

#### Acknowledgement

Via front panel keys or digital signals

#### Real-time alarms

Number 2

Programmable Time  
Day  
Duration

**Totalizer**

Number	2 (freely assignable) 9 digit total
Type	Analog, digital, frequency or pulse
Statistical calculations	Average, maximum, minimum (for analog signals)
Update rate	125 ms

**Maths blocks**

Number	8
Operators	+, -, x, / Average, Maximum, Minimum High / Low / Median Select Square root Multiplexer

**Delay timers**

Number	2
Programmable	Delay Duration

**Logic Equations**

Number	8
Elements	15 per equation
Operators	OR, AND, NOR, NAND, NOT, EXOR

**Custom linearizer**

Number	2
Elements	20 breakpoints

---

**Analog inputs**

**Universal process inputs**

Number	2 (1 standard, 1 optional)
Type	Voltage Current Resistance (ohms) 3-Wire RTD Thermocouple Digital volt-free Digital 24 V Frequency (Input 1) Pulse

**Non-universal process inputs**

Number	2 (1 standard, 1 optional)
Type	Voltage Current Thermocouple (if associated universal input is configured as thermocouple) Digital volt-free Digital 24 V

**Thermocouple types**

B, E, J, K, L, N, R, S, T

**Resistance thermometer**

Pt100

**Other linearizations**

$\sqrt{x}$ ,  $x^{3/2}$ ,  $x^{5/2}$ , custom linearization

**Digital filter**

Programmable 0 to 60 s

**Display range**

-9999 to 99999

**Update rate**

125 ms

**Common mode noise rejection**

>120 dB at 50 / 60 Hz with 300  $\Omega$  imbalance resistance

**Normal (series) mode noise rejection**

>60 dB at 50 / 60 Hz

**CJC rejection ratio**

0.050  $^{\circ}\text{C} / ^{\circ}\text{C}$  change in ambient temperature

**Temperature stability**

0.02 % /  $^{\circ}\text{C}$  or 2  $\mu\text{V} / ^{\circ}\text{C}$  (1  $\mu\text{V} / ^{\circ}\text{F}$ )

**Long term (input) drift**

<0.1 % of reading or 10  $\mu\text{V}$  annually

**Input impedance**

>10  $\text{M}\Omega$  (millivolts input)  
10  $\Omega$  (mA input)

**Inputs**

Thermocouple	Maximum Range °C (°F)	Accuracy (% of reading)
B <sup>#</sup>	-18 to 1800 (0 to 3270)	0.1 % or ±2 °C (3.6 °F) (above 200 °C [392 °F]) *
E	-100 to 900 (-140 to 1650)	0.1 % or ±0.5 °C (0.9 °F)
J	-100 to 900 (-140 to 1650)	0.1 % or ±0.5 °C (0.9 °F)
K	-100 to 1300 (-140 to 2350)	0.1 % or ±0.5 °C (0.9 °F)
L	-100 to 900 (-140 to 1650)	0.1 % or ±1.5 °C (2.7 °F)
N	-200 to 1300 (-325 to 2350)	0.1 % or ±0.5 °C (0.9 °F)
R <sup>#</sup>	-18 to 1700 (0 to 3000)	0.1 % or ±1 °C (1.8 °F) (above 300 °C [540 °F])
S <sup>#</sup>	-18 to 1700 (0 to 3000)	0.1 % or ±1 °C (1.8 °F) (above 200 °C [392 °F])
T <sup>#</sup>	-250 to 300 (-400 to 550)	0.1 % or ±0.5 °C (0.9 °F) (above -150 °C [-238 °F])

<sup>#</sup> For B, R, S and T thermocouples, accuracy is not guaranteed below the value stated.

RTD	Maximum Range °C (°F)	Accuracy (% of reading)
Pt100	-200 to 600 (-325 to 1100)	0.1 % or ±0.5 °C (0.9 °F)

Linear Inputs	Standard Analog Input	Accuracy (% of reading)
Millivolts	0 to 150 mV	0.1 % or $\pm 20 \mu\text{V}$
Milliamps	0 to 50 mA	0.2 % or $\pm 4 \mu\text{A}$
Volts	0 to 25 V	0.2 % or $\pm 20 \text{mV}$
Resistance $\Omega$ (low)	0 to 550 $\Omega$	0.2 % or $\pm 0.1 \Omega$
Resistance $\Omega$ (high)	0 to 10 k $\Omega$	0.1 % or $\pm 0.5 \Omega$
Sample Interval	125 ms per sample	

Digital Inputs	
Type	Volt-free or 24 V
Minimum pulse duration	Analog inputs 1 and 2: <ul style="list-style-type: none"> <li>■ Single inputs configured – 250 ms</li> <li>■ Both inputs configured as analog or digital – 500 ms</li> </ul> Analog inputs 3 and 4: <ul style="list-style-type: none"> <li>■ Single inputs configured – 250 ms</li> <li>■ Both inputs configured as analog or digital – 500 ms</li> </ul> Consider analog inputs 1 / 2 and 3 / 4 independently

Frequency input*	
Frequency range	0 to 6000 Hz
1-signal	15 to 30 V
0-signal	-3 to 5 V

\*For use with devices with open collector outputs

## Outputs

### Controls / retransmission outputs

Number	2 (1 standard, 1 optional)
Type	Configurable as analog or digital pulse
Isolation	Galvanically isolated from the rest of the circuitry, 500 V for 1 minute
Analog range	0 to 20 mA Programmable
Load	750 Ω Max.
Accuracy	0.25 % of output or +/- 10 µA

### Relays

Number	CM30: 4 (1 standard, 3 optional) CM50: 4 (2 standard, 2 optional)
Type	CM30: Standard with changeover contacts. Optional contacts selectable as N/O or N/C (by jumper) CM50: Selectable as N/O or N/C (by jumper)
Contact ratings	5 A, 240 V
Update rate	125 ms

### Digital input / output

Number	CM30: 6 (2 standard, 4 optional) CM50: 6 (2 standard, 4 optional)
Type	User-programmable as input or output Minimum input pulse duration – 125 ms <ul style="list-style-type: none"> <li>■ Input                     <ul style="list-style-type: none"> <li>– volt-free or 24 V DC</li> <li>– 1-signal: 15 to 30 V</li> <li>– 0-signal: -3 to 5 V</li> <li>– Conforms to IEC 61131-2</li> </ul> </li> <li>■ Output                     <ul style="list-style-type: none"> <li>– Open collector output</li> <li>– 30 V, 100 mA max.</li> <li>– Conforms to IEC 61131-2</li> </ul> </li> </ul>
Update rate	125 ms

### 2-Wire transmitter power supply

Voltage	24 V DC
Number	2 (1 standard, 1 optional)
Drive	2 Loops for each transmitter PSU, 45 mA max.

## Communications

For MODBUS and Ethernet communications see separate User Guide (IM/CM/C-EN).

### Infrared port

Baud rate	up to 115 kBaud
Distance	up to 1 m
Functions	firmware upgrade, configuration upload / download

## EMC

### Emissions & immunity

Meets requirements of IEC61326 for an Industrial Environment

## Environmental

### Operating temperature range

-0 to 55 °C (32 to 131 °F)

### Operating humidity range

5 to 95 %RH (non-condensing)

### Storage temperature range

-20 to 70 °C (-4 to 158 °F)

### Enclosure sealing

Front face	IP66 / NEMA 4X
Rest of enclosure	IP20

### Vibration

Conforms to EN60068-2-6

## Safety

### Approvals and certifications

EN61010-1

cULus

### General safety

Pollution category 2

Insulation category 2

### Isolation (to inputs)

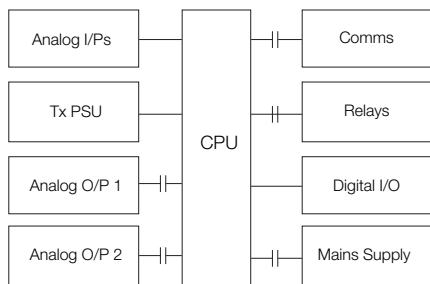

### Key

—||— = Isolation

## Physical

### Size

CM30 97 x 97 x 141 mm (3.8 x 3.8 x 5.5 in.)

CM50 144 x 76 x 146 mm (5.6 x 3.0 x 5.7 in.)

### Weight

CM30 0.5 kg (1.1 lb) approx. (unpacked)

CM50 0.57 kg (1.27 lb) approx. (unpacked)

### Panel cutout

CM30 92 x 92 mm (3.6 x 3.6 in.),  
 121 mm (4.8 in.) behind panel

CM50 138 x 68 mm (5.4 x 2.7 in.),  
 123 mm (4.9 in.) behind panel

### Case material

Glass-filled polycarbonate

DS/CM30-EN Rev. J  
 DS/CM50-EN Rev. J

## Electrical

### Supply ranges

100 to 240 V AC  $\pm 10\%$

(90 V min. to 265 V max.) 50 / 60 Hz

10 to 36 V DC (optional)

### Power consumption

10 W max.

### Power interruption protection

No effect for interrupts of up to 60 ms



## Appendix A – Digital and Analog Sources

**Note.** Numbers in brackets indicate additional parameters, for example, *Alarm 1 (8) Ack. State* indicates that 8 *Alarm Ack. State* parameters are available.

### A.1 Digital Sources

Source Name	Description [Comment]
Alarm 1 (8) Ack. State	Acknowledged alarm = 0 Unacknowledged alarm = 1
Alarm 1 (8) State	Alarm state
Anlg IP 1 (4) Fail	Analog Input Failure (active when the signal detected at the analog input is outside the fault detect level specified during configuration).
AO1 (2) Loop Break	Analog output
Delay Timer 1 (2)	Delay timer state
IP 1 (4) Digital State	Input 1 (4) digital state
Linearizer 1 (2) Fail	Custom linearizer failure
Logic Equation 1 (8)	Logic equation result
Loop 1 SP Mode	Setpoint mode selected 0 = Local, 1 = Remote
Loop 1 Auto Mode	Automatic control mode
Loop 1 Close Relay	Motorized valve close relay state
Loop 1 LSP 1 (4) State	Local setpoint state 1 = setpoint selected
Loop 1 Manual Mode	Manual control mode 1 = Manual

Source Name	Description [Comment]
Loop 1 Open Relay	Motorized valve open relay state
Loop 1 TP OP1	Time proportioning output
Loop 1 Valve State	Motorized valve state
Loop 1 Valve Stuck	Motorized valve stuck state
Loop 1 Ctrl Track	Control track state
Math Block 1 (8) Fail	Maths failure
RTA 1 (2) State	Real time alarm state
Softkey Toggle	Front panel soft key toggles the source's state
Softkey Edge	Front panel soft key sets the source active on key press
T1 (2) Int Pulse	Totalizer intermediate pulse – active for 1 second when the intermediate count is reached
T1 (2) Run State	Totalizer run state 1 = Totalizer running
T1 (2) Wrap Pulse	Totalizer wrap pulse If <i>Wrap Enable</i> is <i>On</i> – active for 1 second when the predetermined count is reached <i>Off</i> – active when the predetermined count has been reached and remains active until the totalizer is reset

## A.2 Analog Sources

Source Name	Description
Anlg IP 1 (4)	Analog input
Constant 1 (8)	Math block constant
Linearizer 1 (2)	Custom linearizer
Loop 1 Actual Ratio	Loop 1 (2) actual ratio. Applies to ratio application templates only
Loop 1 Control OP	Control output value
Loop 1 Deviation	Loop 1 (2) deviation
Loop 1 Feedforward	Loop 1 (2) output of feedforward block
Loop 1 LSP	Local setpoint loop
Loop 1 PV	Loop 1 (2) process variable
Loop 1 Ration	Loop 1 (2) desired ratio Loop
Loop 1 SP	Loop control setpoint
Loop 1 Split OP1	Loop 1 split output
Loop 1 Valve Pos	Motorized valve position
Loop Bias 1	Loop 1 desired bias
Math Block 1 (8)	Math block
PV1 (2) Average	Process variable average
PV1 (2) Max	Maximum value of process variable 1 (2)
PV1 (2) Min	Minimum value of process variable 1 (2)
T1 (2) Batch Total	Totalizer batch total
T1 (2) Secure Total	Totalizer secure total
User Value 1 (2)	(Profile only)
Volume 1 (2)	(Indicator only)

## Appendix B – Configuration Error Codes

Configuration errors are generated when a signal assigned as a source for something has failed. Configuration errors are displayed as numerical codes and a description of each code is shown in the following tables:

Error Code	Error Description
1	Analog Input Value A1 (I/P 1)
2	Analog Input Value A2 (I/P 2)
3	Analog Input Value B1 (I/P 3 – CM50)
4	Analog Input Value B2 (I/P 4 – CM50)
5	Analog Input Value C1 (I/P 3 – CM30)
6	Analog Input Value C2 (I/P 4 – CM30)
9	Setpoint Selected LSPT Value 1
10	Setpoint Control Setpoint Value 1
11	Setpoint Selected Ratio Value 1
12	Setpoint Selected Bias Value 1
13	Setpoint Actual Ratio Value 1
14	Setpoint Selected LSPT Value 2
15	Setpoint Control Setpoint Value 2
16	Setpoint Selected Ratio Value 2
17	Setpoint Selected Bias Value 2
18	Setpoint Actual Ratio Value 2
19	Modbus Input Value 1
22	Totalizer Batch total 1
23	Totalizer Secure Total 1
24	Totalizer Batch total 2
25	Totalizer Secure Total 2
26	Maths Block Value 1
27	Maths Block Value 2
28	Maths Block Value 3
29	Maths Block Value 4
30	Maths Block Value 5
31	Maths Block Value 6
32	Maths Block Value 7
33	Maths Block Value 8
34	Maths Block Constant 1
35	Maths Block Constant 2
36	Maths Block Constant 3
37	Maths Block Constant 4
38	Maths Block Constant 5
39	Maths Block Constant 6
40	Maths Block Constant 7
41	Maths Block Constant 8
42	Control Output Value 1
43	Control Output Value 2

Error Code	Error Description
44	Dual Output Loop 1 Value 1
45	Dual Output Loop 1 Value 2
46	Dual Output Loop 2 Value 1
47	Dual Output Loop 2 Value 2
48	Mot Valve Output 1
49	Mot Valve Output 2
50	PV Maximum Value 1
51	PV Minimum Value 1
52	PV average Value 1
53	Volume Value 1
54	PV Maximum Value 2
55	PV Minimum Value 2
56	PV average Value 2
57	Volume Value 2
58	Customer Linearizer Value 1
59	Customer Linearizer Value 2
60	Profile User Value 1
61	Profile User Value 2
62	Mot Valve Position 1
63	Mot Valve Position 2
64	template Block PV Value 1
65	Template Block PV Value 2
66	Template Block Deviation Value 1
67	Template Block Deviation Value 2
68	Template Block Feed forward Value 1
69	Template Block Feed forward Value 2
70	Analog Input Fail State A1
71	Analog Input Fail State A2
72	Analog Input Fail State B1
73	Analog Input Fail State B2
74	Analog Input Fail State C1
75	Analog Input Fail State C2
76	Maths Block Fail State 1
77	Maths Block Fail State 2
78	Maths Block Fail State 3
79	Maths Block Fail State 4
80	Maths Block Fail State 5
81	Maths Block Fail State 6
82	Maths Block Fail State 7

Error Code	Error Description
83	Maths Block Fail State 8
84	Custom Linearizer Fail State 1
85	Custom Linearizer Fail State 2
94	Analog Input State A1 (I/P 1)
95	Analog Input State A2 (I/P 2)
96	Analog Input State B1 (I/P 3 – CM50)
97	Analog Input State B2 (I/P 4 – CM50)
98	Analog Input State C1 (I/P 3 – CM30)
99	Analog Input State C2 (I/P 4 – CM30)
100	Setpoint Remote Mode State 1
101	Setpoint LSPT 1 Selected State 1
102	Setpoint LSPT 2 Selected State 1
103	Setpoint LSPT 3 Selected State 1
104	Setpoint LSPT 4 Selected State 1
105	Setpoint Remote Mode State 2
106	Setpoint LSPT 1 Selected State 2
107	Setpoint LSPT 2 Selected State 2
108	Setpoint LSPT 3 Selected State 2
109	Setpoint LSPT 4 Selected State 2
110	Digital Input State 1
111	Digital Input State 2
112	Digital Input State 3
113	Digital Input State 4
114	Digital Input State 5
115	Digital Input State 6
123	Totalizer Run State 1
124	Totalizer Wrap Pulse 1
125	Totalizer Intermediate Pulse 1
126	Totalizer Run State 2
127	Totalizer Wrap Pulse 2
128	Totalizer Intermediate Pulse 2
131	Logic Equation Result 1
132	Logic Equation Result 2
133	Logic Equation Result 3
134	Logic Equation Result 4
135	Logic Equation Result 5
136	Logic Equation Result 6
137	Logic Equation Result 7
138	Logic Equation Result 8
139	Real Time Alarm State 1
140	Real Time Alarm State 2

Error Code	Error Description
141	Alarm State 1
142	Alarm Ack State 1
143	Alarm State 2
144	Alarm Ack State 2
145	Alarm State 3
146	Alarm Ack State 3
147	Alarm State 4
148	Alarm Ack State 4
149	Alarm State 5
150	Alarm Ack State 5
151	Alarm State 6
152	Alarm Ack State 6
153	Alarm State 7
154	Alarm Ack State 7
155	Alarm State 8
156	Alarm Ack State 8
157	Time Prop State 1
158	Time Prop State 2
159	Time Prop State 3
160	Time Prop State 4
161	Control O/P Auto State 1
162	Control O/P Manual State 1
163	Control O/P Track Status 1
164	Control O/P Auto State 2
165	Control O/P Manual State 2
166	Control O/P Track Status 2
167	Analog O/P Loop break A1
168	Analog O/P Loop break B1
169	Mot Valve Close Relay State 1
170	Mot Valve Open Relay State 1
171	Mot Valve Sticking State 1
172	Mot Valve Tri State 1
173	Mot Valve Tri State 2
174	Mot Valve Close Relay State 2
175	Mot Valve Open Relay State 2
176	Mot Valve Sticking State 2
177	Delay Timer State 1
178	Delay Timer State 2
189	Toggle Signal
190	Edge Signal

## Appendix C – Analog Input Engineering Units

Unit	Description
%	%
% sat	% saturation
%dO2	% dissolved oxygen
%HCl	% hydrochloric acid
%N2	% nitrogen
%O2	% oxygen
%OBS	% obscuration
%RH	% relative humidity
A	amps
bar	bar
CUMEC	cubic metre per second
deg C / F	degrees Celsius / Fahrenheit
Feet	imperial feet
ft <sup>3</sup> /d, ft <sup>3</sup> /h, ft <sup>3</sup> /m, ft <sup>3</sup> /s	cubic feet per day, hour, minute, second.
FTU	formazine turbidity units
g/d, g/h, g/l	grams per day, hour, liter
gal/d (UK)	imperial gallons per day
gal/d (US)	US gallons per day
gal/h (UK) / (US)	imperial / US gallons per hour
gal/m, s (UK) / (US)	imperial / US gallons per minute, second.
Hz	hertz
Inches	imperial inches
Kelvin	degrees Kelvin
kg/d, kg/h, kg/m	kilograms per day, hr., min.
kg/s	kilograms per sec.
kHz	kilohertz
l/d, l/h, l/m, l/s	liters per day, hour, min., sec.

Unit	Description
lb/d, lb/h, lb/m, lb/s	pounds per day, hour, minute, second.
m WG	meters water gauge
m <sup>3</sup> /d, m <sup>3</sup> /h, m <sup>3</sup> /m, m <sup>3</sup> /s	cubic meters per day, hour, minute, second..
mbar	millibar
mg/kg	milligrams per kilogram
Mgal/d (UK)	imperial mega gallons per day
Mgal/d (US)	US mega gallons per day
mho	conductance
MI/d, MI/h	megaliters per day, hour.
ml/h, ml/m	millilitres per hour, minute.
MI/s	megaliters per second
mS/cm, mS/m	milliSiemens per centimeter, meter
mV	millivolts
MV	megavolts
NTU	nephelometric turbidity units
pb	parts per billion
pH	potential Hydrogen
pm	parts per million
psi	pounds per square inch
S	Siemens
SCFM	standard cubic feet per minute
T/d, T/h, T/m	metric tonnes per day, hour, minute.
T/s	metric tonnes per second
ton/d, ton/h, ton/m, ton/s	imperial tons per day, hour, minute, second.
ug/kg	micrograms per kilogram
uS/cm, uS/m	microSiemens per centimeter / meter
uV	microvolts

## Appendix D – Output Type Assignments

Output Type	AO 1	AO 2	DIO 1	DIO 2	RLY1	RLY2	RLY3	RLY4
Analog	OP	PV			ALM 1	ALM 2	ALM 3	ALM 4
Time Proportioning	PV	SP			OP	ALM 1	ALM 2	ALM 3
MValve + Feedback	PV	SP			Open V	Close V	ALM 1	ALM 2
MValve Boundless	PV	SP	OP 2		Open V	Close V	ALM 1	ALM 2
Split Output Analog / Relay	OP 1	PV			OP 2	ALM 1	ALM 2	ALM 3
Split Output Analog / Digital	OP 1	PV	OP 2		ALM 1	ALM 2	ALM 3	ALM 4
Split Output Relay / Relay	PV	SP			OP 1	OP 2	ALM 1	ALM 2
Split Output Relay / Digital	PV	SP	OP 2		OP 1	ALM 1	ALM 2	ALM 3
Split Output Digital / Relay	PV	SP	OP 1		OP 2	ALM 1	ALM 2	ALM 3
Split Output Digital / Digital	PV	SP	OP 1	OP 2	ALM 1	ALM 2	ALM 3	ALM 4
Split Output Analog / Analog	OP 1	OP 2			ALM 1	ALM 2	ALM 3	ALM 4

# Products and customer support

## Automation Systems

For the following industries:

- Chemical & Pharmaceutical
- Food & Beverage
- Manufacturing
- Metals and Minerals
- Oil, Gas & Petrochemical
- Pulp and Paper

## Drives and Motors

- AC and 6 Drives, AC and DC Machines, AC Motors to 1kV
- Drive Systems
- Force Measurement
- Servo Drives

## Controllers & Recorders

- Single and Multi-loop Controllers
- Circular Chart and Strip Chart Recorders
- Paperless Recorders
- Process Indicators

## Flexible Automation

- Industrial Robots and Robot Systems

## Flow Measurement

- Electromagnetic Flowmeters
- Mass Flowmeters
- Turbine Flowmeters
- Wedge Flow Elements

## Marine Systems & Turbochargers

- Electrical Systems
- Marine Equipment
- Offshore Retrofit and Refurbishment

## Process Analytics

- Process Gas Analysis
- Systems Integration

## Transmitters

- Pressure
- Temperature
- Level
- Interface Modules

## Valves, Actuators and Positioners

- Control Valves
- Actuators
- Positioners

## Water, Gas & Industrial Analytics Instrumentation

- pH, Conductivity and Dissolved Oxygen Transmitters and Sensors
- Ammonia, Nitrate, Phosphate, Silica, Sodium, Chloride, Fluoride, Dissolved Oxygen and Hydrazine Analyzers
- Zirconia Oxygen Analyzers, Katharometers, Hydrogen Purity and Purge-gas Monitors, Thermal Conductivity

## Customer support

We provide a comprehensive after sales service via a Worldwide Service Organization. Contact one of the following offices for details on your nearest Service and Repair Centre.

### UK

ABB Limited  
Tel: +44 (0)1480 475321  
Fax: +44 (0)1480 217948

### USA

ABB Inc.  
Tel: +1 215 674 6000  
Fax: +1 215 674 7183

#### Client Warranty

Prior to installation, the equipment referred to in this manual must be stored in a clean, dry environment, in accordance with the Company's published specification.

Periodic checks must be made on the equipment's condition. In the event of a failure under warranty, the following documentation must be provided as substantiation:

- A listing evidencing process operation and alarm logs at time of failure.
- Copies of all storage, installation, operating and maintenance records relating to the alleged faulty unit.

# Contact us

## **ABB Limited**

### **Process Automation**

Howard Road

St. Neots

Cambridgeshire PE19 8EU

UK

Tel: +44 (0)1480 475321

Fax: +44 (0)1480 217948

## **ABB Inc.**

### **Process Automation**

125 E. County Line Road

Warminster

PA 18974

USA

Tel: +1 215 674 6000

Fax: +1 215 674 7183

[www.abb.com](http://www.abb.com)

#### Note

We reserve the right to make technical changes or modify the contents of this document without prior notice. With regard to purchase orders, the agreed particulars shall prevail. ABB does not accept any responsibility whatsoever for potential errors or possible lack of information in this document.

We reserve all rights in this document and in the subject matter and illustrations contained therein. Any reproduction, disclosure to third parties or utilization of its contents in whole or in parts – is forbidden without prior written consent of ABB.

Copyright© 2012 ABB

All rights reserved

IM/CM/ED-EN Rev. L 11.2012