

ABB Ability™ System 800xA® 6.2

Meet tomorrow's automation project challenges, today.



System 800xA 6.2 is available for new and existing installations demonstrating ABB's commitment to solving automation project execution, integration, and cost of ownership challenges.

System 800xA 6.2 includes new features and performance enhancements to tackle what end users and system integrators deal with when engineering current and future automation projects. Also included is support for the latest technology trends and standards, quality enhancements, and lifecycle updates to ensure safe and secure, 24/7 operations.

System 800xA 6.2 — Reducing project costs and complexity for networked I/O and device installations:

- **100% increase** in supported networked I/O stations and devices on AC 800M's Ethernet based I/O network via the CI871A (PROFINET) Communications Interface Module.
- Native integration **support for Ethernet APL** devices through System 800xA's Device Import Wizard.
- Native connectivity to ABB and 3rd party **PROFIsafe devices** for use in SIL applications to reduce any unnecessary hardware and costs in safety projects.
- New **Ethernet I/O Marshalling Tool** that assists project engineers in the distribution of individual Select I/O channels for up to 10 different AC 800M controllers.

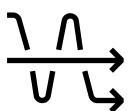

Reduces complexity for automation projects

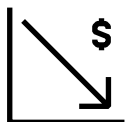

Reduces overall cost of automation system ownership



Ensures dependable, safe, and secure operations

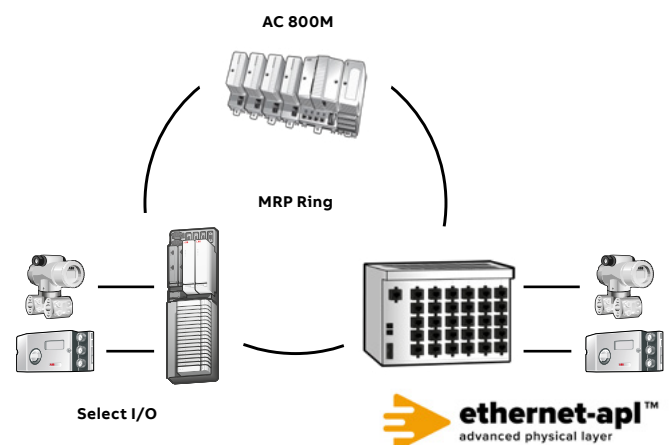

Learn more about System 800xA 6.2

More medium to large projects include a mixture of Ethernet based I/O, networked process instrumentation, and intelligent electrical devices.

Additional features in this version:

- Improved, safe, secure communications with **OPC UA** Client Connect providing access to System 800xA's History, Alarms & Conditions for 3rd party data consumers.
- Support for the latest **Modular Automation** Modular Types Package (MTP) standards in System 800xA's Orchestration Designer.
- Introduction of a zero install, zero maintenance **HTML5** based operations and alarm client solution that uses existing PG2 graphics and pre-configured alarm lists.
- Support for **Microsoft Defender Antivirus** reducing installation effort and cost.
- Lifecycle updates of 3rd party software, such as **VMware vSphere 8** and **MS Office 2021**, and quality corrections that reduce maintenance costs and ensure System 800xA installations run at their optimum level.
- System 800xA **supports multiple operating systems** to allow for flexible upgrade/update paths. System 800xA 6.2 supports both Windows 2022 and 2019 LTSC versions.

System 800xA Modular Orchestration



ABB Ability™ System 800xA

The Power of Integration

System 800xA is an all-in-one automation solution used in practically every industrial process application. At its core, it is an automation integration platform that is able to assume multiple roles, such as process control, HMI/SCADA, safety, electrical control and monitoring, power management, and more.

Having these different, typically separate systems, together sharing data with each other, promotes a collaborative environment that unveils the hidden plant to improve operational performance, operator effectiveness, personnel productivity, asset utilization, plant uptime, and more!

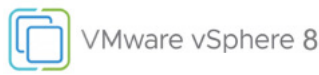
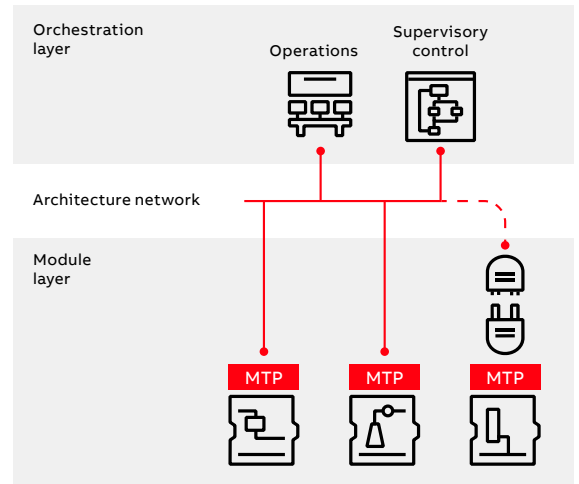
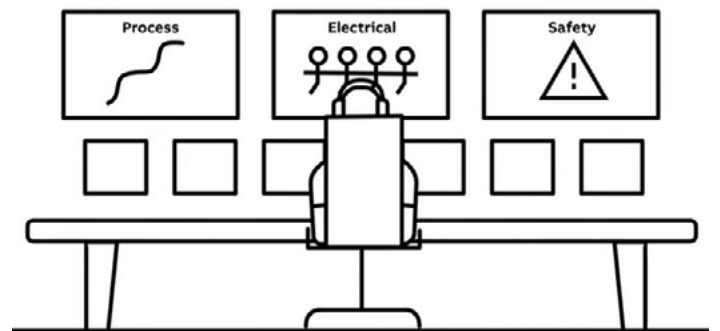

Promoting Collaboration



Dependable 24/7 Operations



Intelligent Engineering



Flexible Control & I/O Solutions



Accelerating Digital Transformation

solutions.abb/800xA



We reserve the right to make technical changes to the products or modify the contents of this document without prior notice. With regard to purchase orders, the agreed particulars shall prevail. ABB does not assume any responsibility for any errors or incomplete information in this document.

We reserve all rights to this document and the items and images it contains. The reproduction, disclosure to third parties or the use of the content of this document – including parts thereof – are prohibited without ABB's prior written permission.

Copyright © 2024 ABB. All rights reserved.