

# Endura AZ30 Combustion oxygen monitor

Proven technology for use in hazardous area gases and dusts

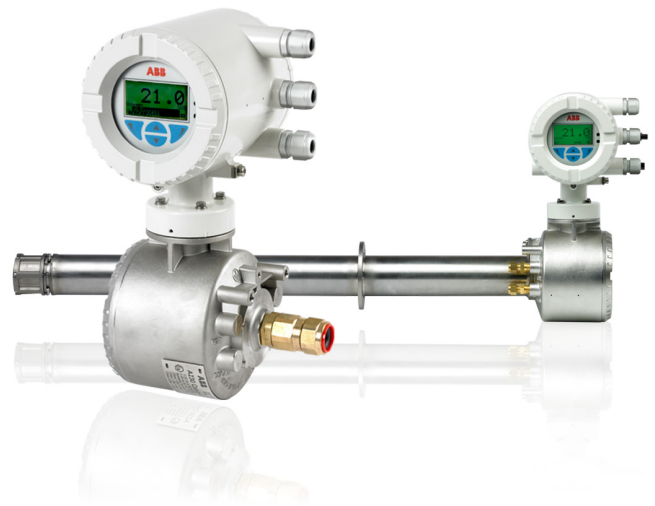

## Hazardous area designations – system

### Certification

- ATEX and IECEx
  - Certified for use in Class I Zone 1 and Zone 2 – gas groups IIA, IIB + H<sub>2</sub>, Class II Zone 21 and Zone 22 – dust group IIIC
- FM USA and Canada
  - Certified for use in Class I Division 1 gas groups BCD, Class II Division 1 dust groups EFG

## Low surface temperature

- Safe T4 135 °C (275 °F) surface temperature rating

## Advanced transmitters

- Easy configuration, monitoring and intuitive HMI
- HART communications
- Cell performance logging and diagnostics

## Advanced design and precision manufacturing

- Robust, long-life probe for process temperatures up to 700 °C (1292 °F)
- Proven cell design from over 50 years experience
- Fast response to process variations
- Stable and accurate oxygen measurement

## Unique integrated auto-calibration system

- Easy compliance for emission monitoring regulation
- Reduced installation costs; eliminates requirement for expensive external calibration panel
- Reduced maintenance costs

## Probe lengths up to 2.0 m (6.6 ft.) and industry-standard flange configurations

- Suitable for a wide range of applications
- Extensive installation options

## Easy cell release

- Fully site-serviceable probe
- Easy access to internal components

# Endura AZ30

## Combustion oxygen monitor

### Introduction

The Endura AZ30 is an explosion-proof / flameproof combustion gas analyzer system designed for use in Hazardous Areas. Certification covers not only the terminal housing, but the complete system.

The sensor, based on a zirconium oxide cell, is mounted at the tip of the probe that is inserted in the flue duct. The resulting direct, in situ measurement provides accurate and rapid oxygen reading for combustion control optimization and emissions monitoring.

### Probe lengths up to 2.0 m (6.6 ft.)

A wide range of probe insertion lengths from 0.5 to 2.0 m (1.7 to 6.6 ft.) enable installation to the optimum measuring point for accurate oxygen measurement within the duct.

A comprehensive range of mounting flanges provide simple installation when plant-wide standard flanges are required or when replacing existing probes.

The transmitter can be probe- or remote-mounted at distances of up to 100 m (328 ft.), providing versatile system options for all applications. The probe-mounted transmitter option provides the lowest cost of installation. However, the remote-mounted transmitter provides flexibility when the operationally ideal probe location does not provide easy access for the user.



Fig. 1: Probe and probe-mounted transmitter

### Advanced design

Designed and manufactured to exacting standards, the Endura AZ30 ensures long periods of trouble-free operation in even the most arduous of applications.

The operating process temperature of up to 700 °C (1292 °F) extends system suitability into previously impossible applications and enables optimum probe location within the process.

The modular design, with reduced component count, improves the robustness and reliability of the system and simplifies routine maintenance and servicing.

Complete traceability ensures only the highest quality materials are used in the system's construction and rigorous manufacturing, inspection and testing procedures (to international standard ISO 9001) result in a monitor of superior quality with prolonged probe life.



Fig. 2: Probe and remote-mounted transmitter

## Easy cell release

The Endura AZ30 probe has retained the easy-access cell arrangement of the previous generation ZFG2 probes. Cell replacement can be performed on-site using basic hand tools; even after long periods of high temperature operation where screw threads have 'seized' and can no longer be released. Kits containing all the parts needed to complete maintenance are available from ABB to ensure a technician can perform services quickly, efficiently and at minimum cost.

### Proven cell design

ABB's metallurgically-bonded, multi-layer electrode technology increases the cell's resistance to sulphurous and reducing atmospheres and high temperature operation. This extends the lifecycle of the cell in the most arduous applications such as sulphur recovery processes, crematoria and industrial / clinical waste incineration.



Fig. 3: Zirconia cell

### Test gas / reference air flow rate control using factory-fitted flow restrictors

The factory-fitted flow restrictors regulate the flow rate of test gases and reference air to the sensor by using a fixed supply pressure of 1 bar (15 psi)  $\pm$ 12 %.

The flow restrictors ensure the following conditions:

- the correct flow of test gases and reference air into the sensor for correct sensor operation
- prevention of pressurization of the sensor's internal volume above 1.1 bar absolute (44 in. WG) under fault conditions such as internal leaks from the gas lines for certification compliance

# Endura AZ30

## Combustion oxygen monitor

### Unique integrated automatic calibration

The optional automatic calibration system eliminates the need for the expensive ancillary equipment required for automatic calibration on traditional flue gas oxygen analyzer systems. ABB's fully integrated, automatic calibration feature controls the test gas sequence and detects test gas availability, eliminating incorrect calibrations due to loss of test gas.

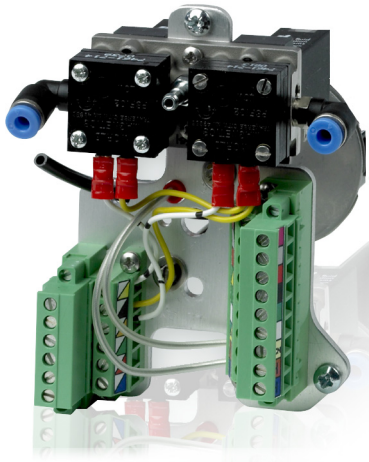

**Fig. 4: Advanced automatic calibration (AutoCal) system**

Integrated automatic calibration secures the oxygen measurement, providing complete confidence in the monitor's performance.

Long-term operation without technician intervention minimizes operating costs, total cost-of-ownership, optimizes system accuracy and contributes to the CEMS (Continuous Emissions Monitoring Compliance). A significant proportion of service visits to an analyzer result in 'no fault found'. Endura AZ30's high-quality manufacture, advanced diagnostics and fully-integrated, automatic calibration is targeted at reducing this wasted effort and cost.

### Advanced transmitter

The Endura AZ30 transmitter incorporates the most up-to-date design and technology available today.

ABB's universal human machine interface (HMI) with its large, clear, backlit graphical display, 'through-the-glass' control and intuitive menu structure simplifies transmitter configuration and operation.

The user-friendly interface enables fast, easy data entry for all parameters and the 'Easy Setup' menu speeds and simplifies system commissioning.

Advanced diagnostics, in accordance with NAMUR NE107, classify alarms and warnings as 'Maintenance Required', 'Check Function', 'Failure' and 'Out-of-Specification'. Cell performance is monitored by the transmitter; indicators such as cell impedance, rate-of-response to test gasses and changes in calibration offset / factor are recorded and analyzed. The current cell 'quality' is displayed by the transmitter as a visual indication of the measurement confidence; providing the operator all the information required to keep the monitor operating at peak performance.

The Performance Log holds up to 100 time-stamped events. When the log is full, the oldest data is overwritten by new entries. The log contains details of measurements and coefficients for all calibrations and accuracy checks.

2 Relay outputs and a traditional analog output are fitted as standard, with the option of adding a second analog output or 2 digital inputs / outputs (I/O).

The Endura AZ30 transmitter is equipped with HART communication as standard, supported by a full Device Type Manager (DTM) to enable remote access to the analyzer through a user-friendly graphical interface. The DTM provides full access to the transmitter setup, logged data and diagnostics information as well as live data. The IrDA standard infrared communication port can also be used with the DTM to upload and download device configurations. In addition, it enables data-logged values and diagnostics to be viewed on a hyperterminal interface or a PC. The transmitter's firmware can also be upgraded using this port.

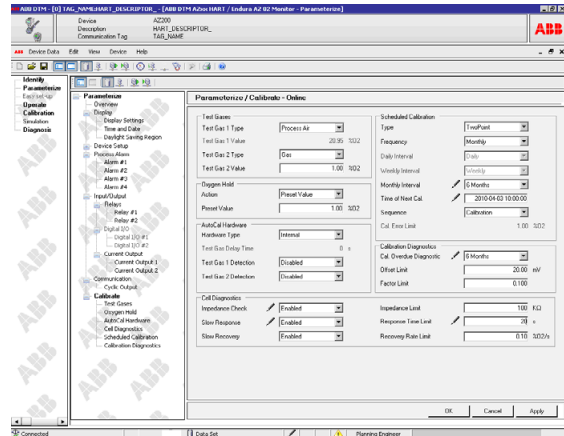
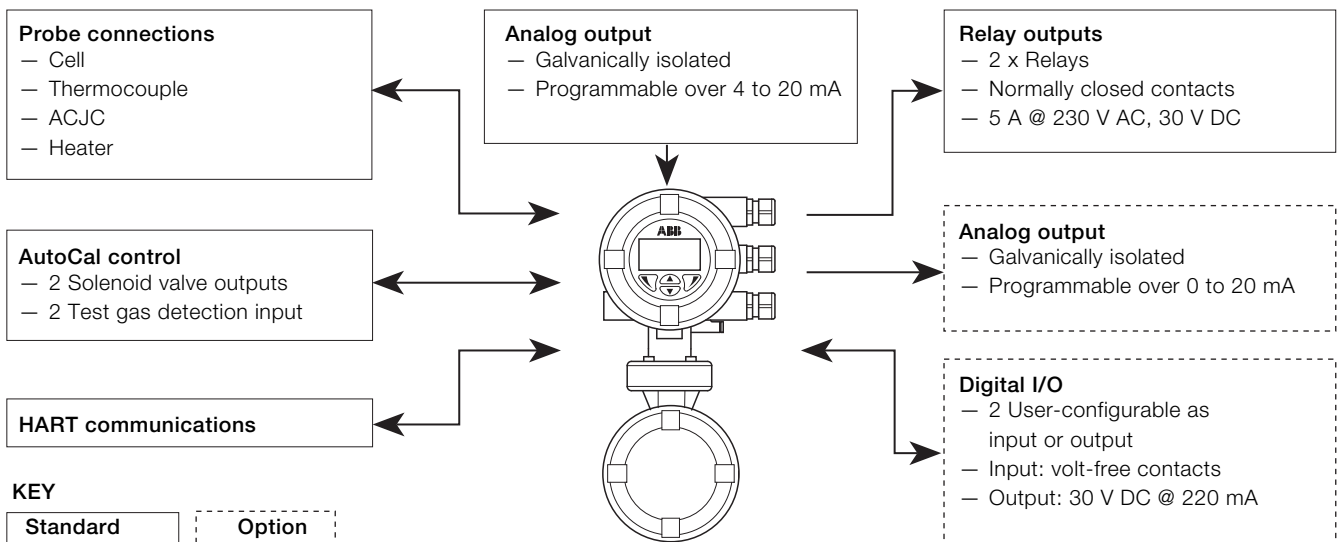

Fig. 5: DTM graphical interface



# Endura AZ30 Combustion oxygen monitor

## AZ30 system options

### Schematic – probe with integral transmitter

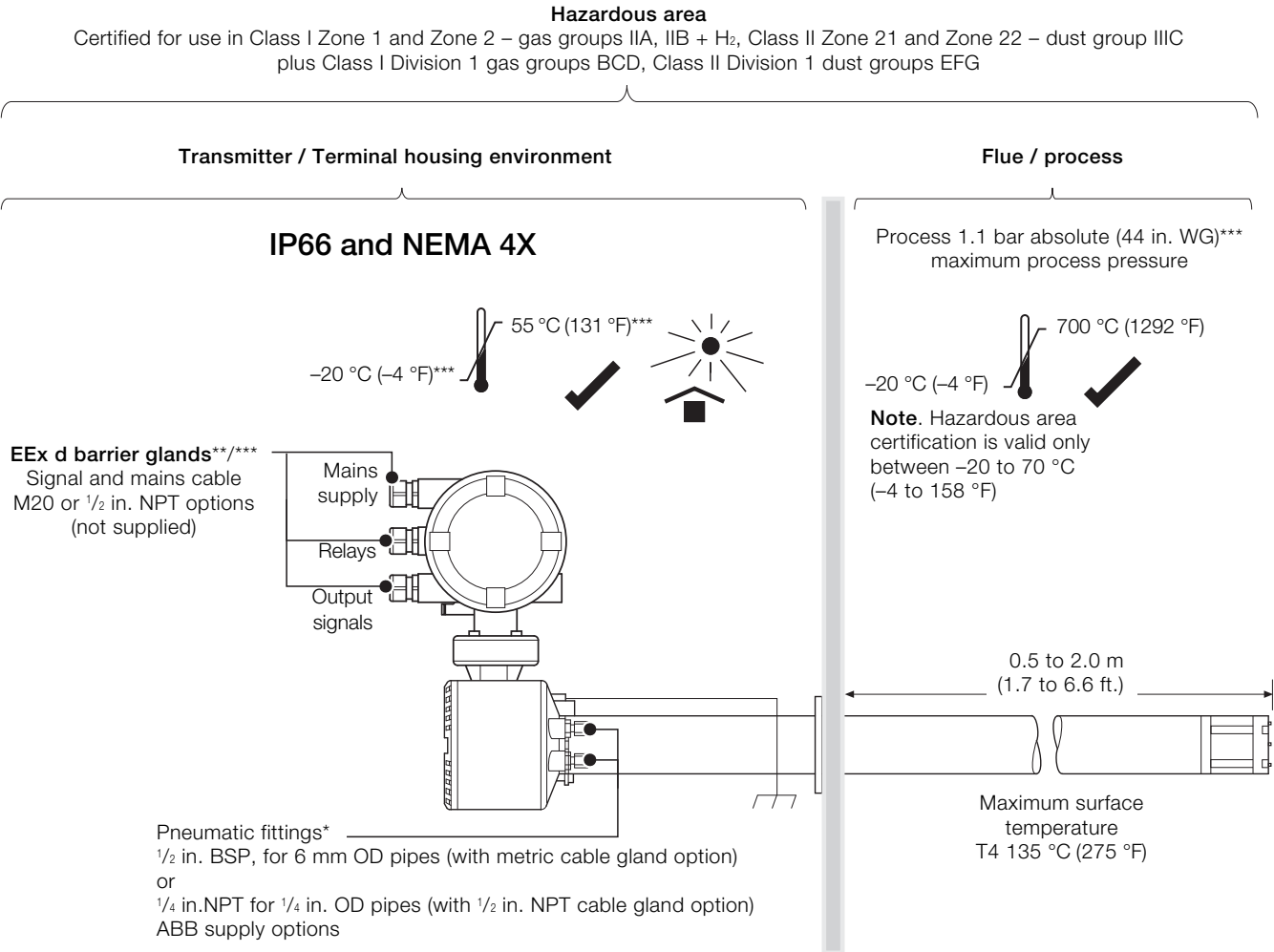

\*Transmitters do not contain a reference air supply for the probe. All external pneumatic fittings may be exchanged – they do not form part of the certified enclosure.

\*\*Refer to page 12 for barrier gland requirements.

\*\*\*Required for certification.

## Schematic – probe with remote transmitter / terminal housing

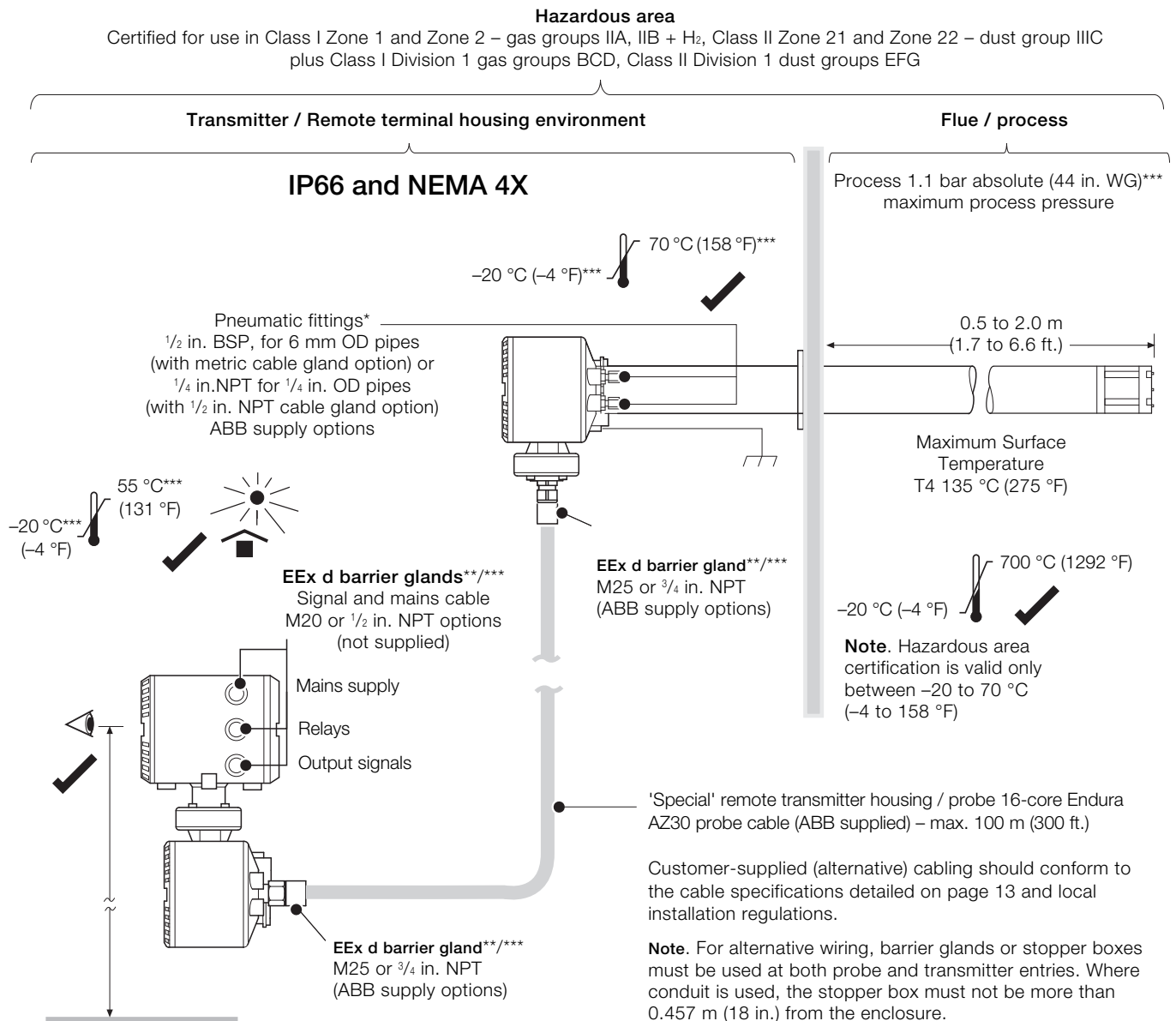

\*Transmitters do not contain a reference air supply for the probe. All external pneumatic fittings may be exchanged – they do not form part of the certified enclosure.

\*\*Refer to page 12 for barrier gland requirements.

\*\*\*Required for certification.

# Endura AZ30

## Combustion oxygen monitor

Test gas and reference air supply configurations – automatic calibration (AutoCal) systems

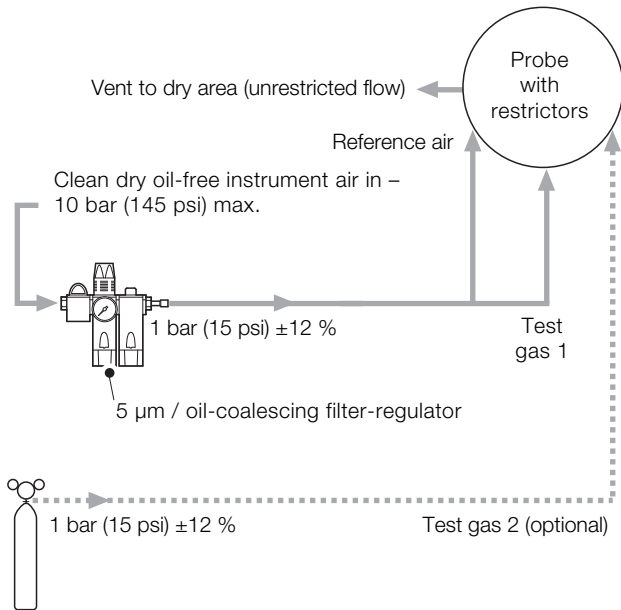

Fig. 6: AutoCal with air as test gas 1

Test gas and reference air supply configurations – non-automatic calibration (non-AutoCal) systems

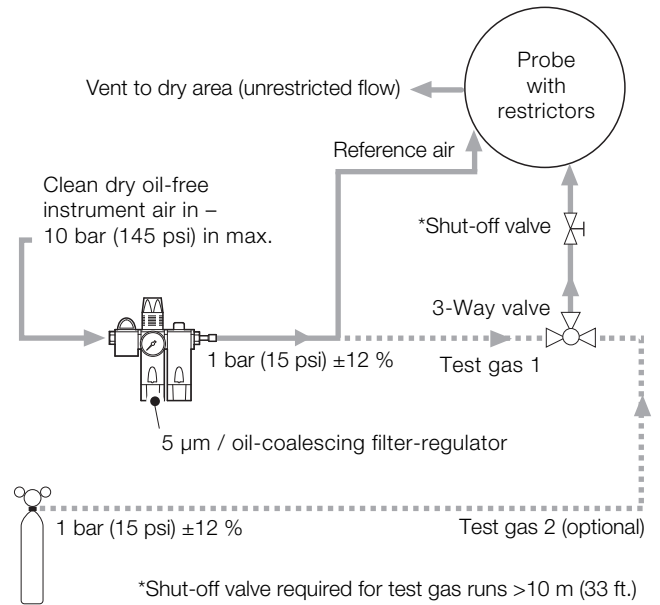

Fig. 8: Non-AutoCal with air as test gas 1

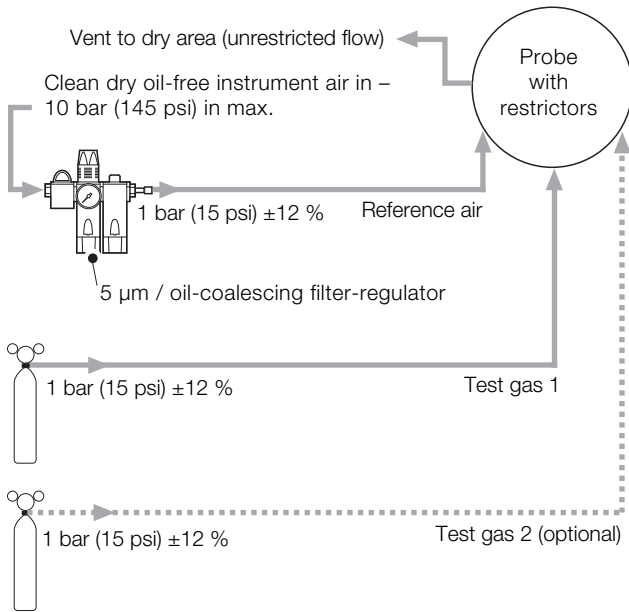

Fig. 7: AutoCal with 2 test gases

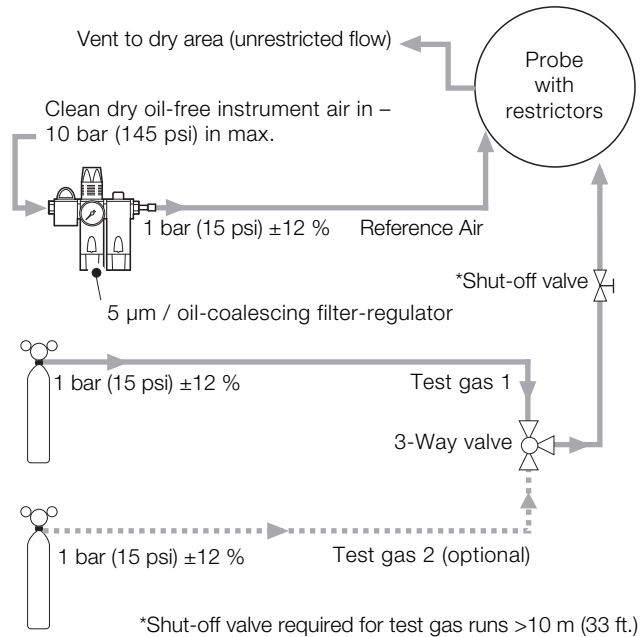

Fig. 9: Non-AutoCal with 2 test gases



# Overall dimensions and weights

## Probe and integral transmitter dimensions

Dimensions in mm (in.)

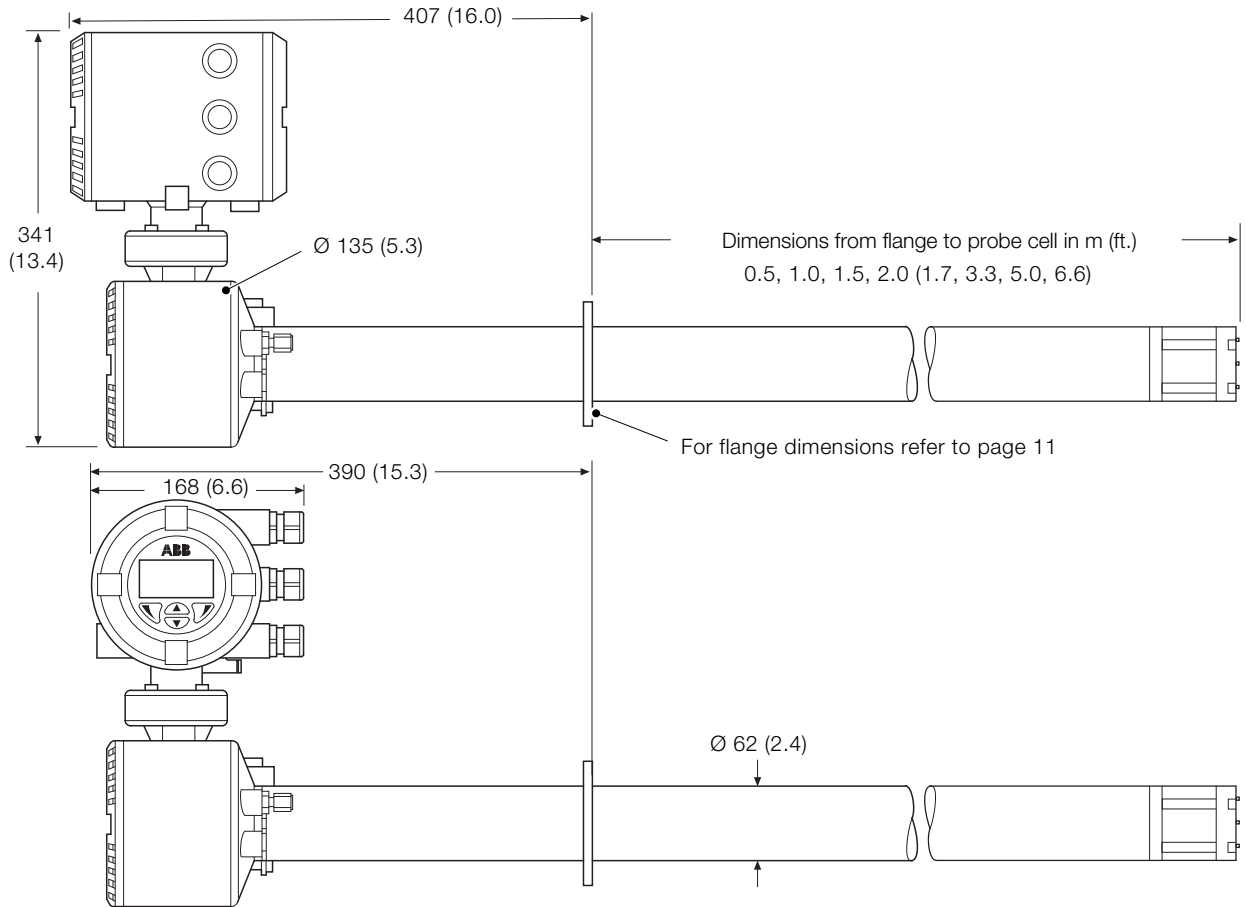

## Probe and integral transmitter weights

Length m (ft.)	Unpacked – kg (lb)	Packed – kg (lb)
0.5 (1.7)	13.32 (29.36)	18.54 (40.87)
1.0 (3.3)	16.44 (36.24)	23.07 (50.86)
1.5 (5.0)	17.0 (42.90)	27.86 (61.42)
2.0 (6.6)	19.3 (49.78)	31.63 (69.73)

# Endura AZ30

## Combustion oxygen monitor

### Remote probe dimensions

Dimensions in mm (in.)

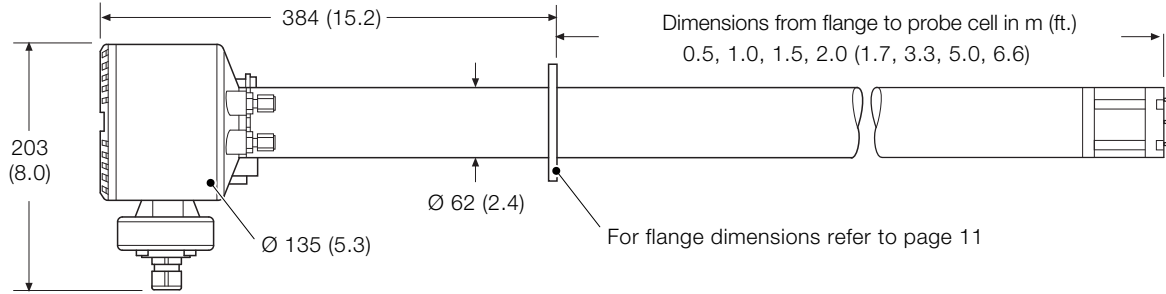

### Remote probe weights

Length m (ft.)	Probe only unpacked – kg (lb)	Probe only packed – kg (lb)
0.5 (1.7)	9.82 (21.65)	15.02 (33.11)
1.0 (3.3)	12.94 (28.53)	19.54 (43.08)
1.5 (5.0)	15.96 (35.18)	24.16 (53.26)
2.0 (6.6)	19.18 (42.28)	28.68 (63.23)

### Remote transmitter dimensions

Dimensions in mm (in.)

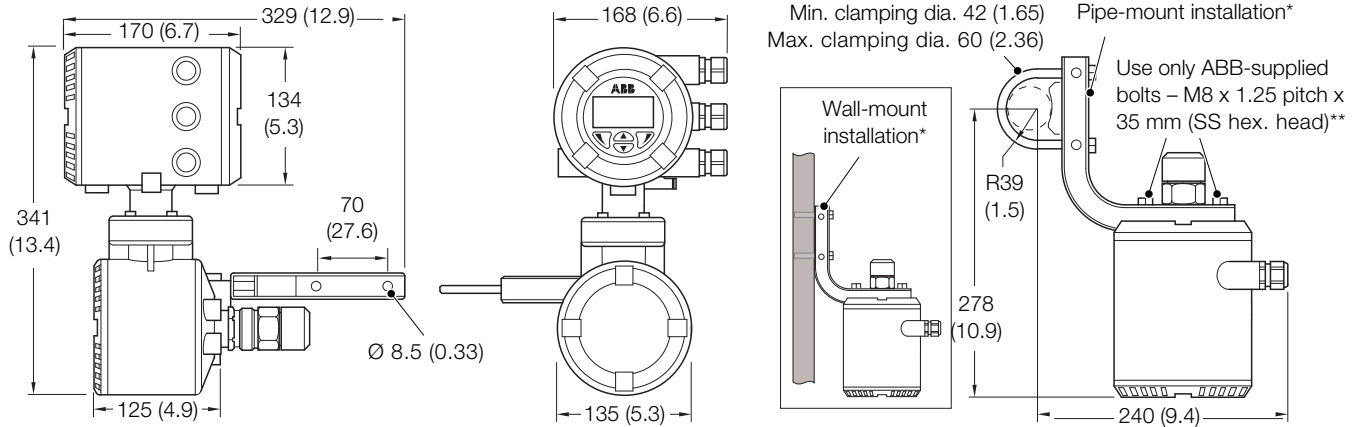

\*Wall- / Pipe-mount bracket plus U-bolt, pipe clamp and M8 fixings supplied as standard

\*\*Certification requirement

### Remote transmitter weights

Remote transmitter unpacked – kg (lb)	Remote transmitter packed – kg (lb)
9.5 (20.94)	12.5 (27.55)

**Probe flanges (all probe lengths) and mounting plates for standard probe flanges**

Dimensions in mm (in.).

**Note.** The pressure ratings for these flanges do not apply.

**ABB probe flange types and dimensions**

Flange type	A	B	C (Ø)	D (PCD)
ABB Standard (0.5 m [1.7 ft.] probes only)	101 (3.97)	6 (0.24)	7.3 (0.29)	80 (3.15)
ABB Standard	165 (6.50)	12 (0.47)	12.5 (0.50)	140 (5.51)

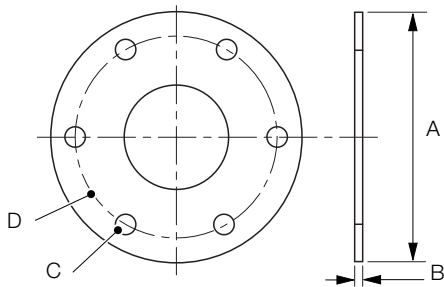

**ABB flange mounting plates\***

Mounting Plate	A	B	C	D
0.5 m (1.7 ft.)	160 (6.3)	160 (6.3)	7 (0.27)	16 (0.63)
1.0 to 2.0 m (3.3 to 6.6 ft.)	203 (8.0)	203 (8.0)	20 (0.79)	32 (1.26)

Standard mounting plate for 0.5 m (1.7 ft.) probe – part no. AZ200 796

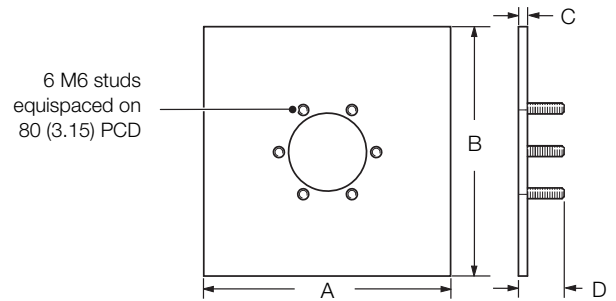

Standard mounting plate for 1.0 to 2 m (3.3 to 6.6 ft.) probes –

Part No. AZ200 795

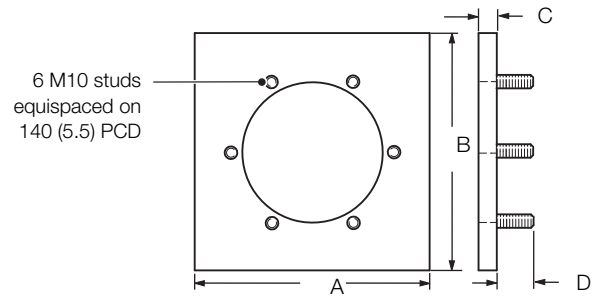

\*Comprising:

- Mounting plate
- Gaskets
- 6 Each:
  - M6 / M10 shakeproof washers
  - M6 / M10 plain washers
  - M6 / M10 nuts

# Endura AZ30

## Combustion oxygen monitor

### 4-hole probe flange types and dimensions

Flange Type	A	B	C (Ø)	D (PCD)
ANSI 2 in 150	152.4 (6.00)	12 (0.47)	19 (0.75)	120.6 (4.75)
ANSI 2.5 in 150	177.8 (7.00)	12 (0.47)	19 (0.75)	139.7 (5.50)
ANSI 3 in 150	190.5 (7.50)	12 (0.47)	19 (0.75)	152.4 (6.00)
DIN 65 PN16	185 (7.28)	12 (0.47)	18 (0.70)	145 (5.70)
JIS 65 5K	155 (6.10)	12 (0.47)	15 (0.59)	130 (5.12)
JIS 80 5K	180 (7.08)	12 (0.47)	19 (0.75)	145 (5.71)

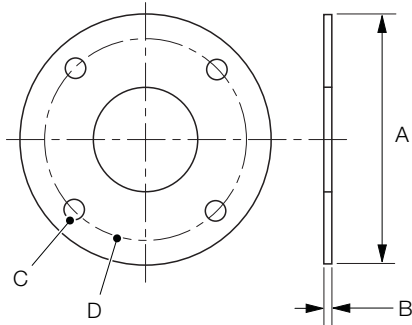

### 8-hole probe flange types and dimensions

Flange Type	A	B	C (Ø)	D (PCD)
ANSI 4 in 150	228.6 (9.0)	12 (0.47)	19 (0.75)	190.5 (7.50)
DIN 80 PN16	200 (7.87)	12 (0.47)	18 (0.70)	160 (6.30)
DIN 100 PN16	220 (8.66)	12 (0.47)	18 (0.70)	180 (7.08)
JIS 100 5K	200 (7.87)	12 (0.47)	19 (0.75)	165 (6.50)

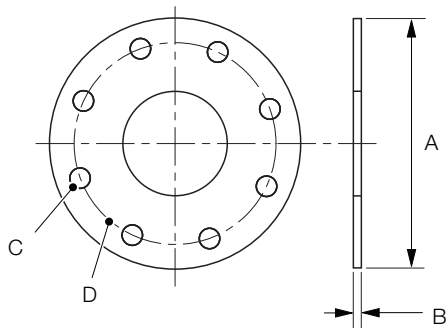

### Barrier gland requirements

#### M25 (or 3/4 in NPT) probe cable glands

If the optional ABB-supplied barrier glands are not used, any M25 or 3/4 in NPT cable glands selected must be of the barrier type, approved for use in hazardous areas and certified suitable for use in Zone 1 and Zone 2 Gas groups IIA, IIB + H<sub>2</sub>, Zone 21, Zone 22 Dust groups IIIC and / or Class I Division 1 Gas groups BCD, Class II Division 1 Dust groups EFG.

- The M25 (or 3/4 in. NPT) barrier cable gland must be suitable for use with the ABB 'special' 16-core cable if ordered with the AZ30 system or for any alternative cable to our specifications – see page 13.
- The M25 (or 3/4 in. NPT) barrier cable gland must provide a standard seal for non-armored cable – refer to cable specifications on page 13.
- An alternative to barrier glands is the use of stopper boxes where local regulations permit.

#### Mains, relay and output signals cable glands – M20 (or 1/2 in NPT)

The M20 (or 1/2 in. NPT) cable glands used on the transmitter must be of the EEx d barrier type, approved for use in hazardous areas. and certified suitable for use in Zone 1 and Zone 2 Gas groups IIA, IIB + H<sub>2</sub>, Zone 21, Zone 22 Dust groups IIIC and / or Class I Division 1 Gas groups BCD, Class II Division 1 Dust groups EFG.

## Probe cable connections – remote transmitter terminal housing to probe

### Standard ABB cable specifications

Tx wire ident number	Terminal label color	(Position) Terminal block connection	Cable color	Cable requirement
Separately screened heater supply				
1	Blue	(1) Heater	Blue	0.75 mm <sup>2</sup>
2	Brown	(2) Heater	Brown	0.75 mm <sup>2</sup>
Heater screen / drain				0.5 mm <sup>2</sup>
Separately screened signal cables				
Chassis earth				0.5 mm <sup>2</sup>
	Yellow (SCN)	(3) Screen (twisted pair / sleeved)	Screens (Yellow / Green)	0.5 mm <sup>2</sup>
4	White	(4) Thermocouple (negative)	White	0.5 mm <sup>2</sup>
5	Green	(5) Thermocouple (positive)	Green	0.5 mm <sup>2</sup>
6	Black	(6) Oxygen input (negative)	Black	0.5 mm <sup>2</sup>
7	Red	(7) Oxygen input (positive)	Red	0.5 mm <sup>2</sup>
8	Grey	(8) PT1000 Cold Junction Compensation	Grey	0.5 mm <sup>2</sup>
9	Violet	(9) PT1000 Cold Junction Compensation	Violet	0.5 mm <sup>2</sup>
10	White / Yellow	(10) Pressure Switch(1) Gas 2	White / Yellow	0.5 mm <sup>2</sup>
11	White /Black	(11) Pressure Switch / Common	White / Black	0.5 mm <sup>2</sup>
12	White / Orange	(12) Pressure Switch / Gas 1	White / Orange	0.5 mm <sup>2</sup>
13	White / Green	(13) Solenoid Valve / Gas 1	White / Green	0.5 mm <sup>2</sup>
14	White / Red	(14) Solenoid Valve / Common	White / Red	0.5 mm <sup>2</sup>
15	White / Blue	(15) Solenoid Valve / Gas 2	White / Blue	0.5 mm <sup>2</sup>
Signal cables screen / drain				0.5 mm <sup>2</sup>

### Requirements for non-ABB supplied cable / conduit

#### Screens and drains:

Heater wires must be sleeved separately from the screened signal cables.

#### Heater cores (items 1 and 2) and heater drain

Heater cores: 0.75 mm<sup>2</sup>, 24/0.2 CU wire, resistance (20C) 26 Ω/km max.

Heater drain: 0.5 mm<sup>2</sup>, 16/0.2 CU wire, resistance (20C) 39 Ω/km max.

#### Signal cores (items 3, 15) and signal drain

Signal cores / signal drain: 0.5 mm<sup>2</sup>, 16/0.2 CU wire, resistance (20C) 39 Ω/Km max.

#### Voltage rating

300 V to earth.

500 V between cores.

#### Cable (non-ABB supply) operating temperature requirements

-20 °C (-4 °F) min.; 80 °C (176 °F) max.

#### Cable conduit (non-ABB supply)

Stainless-steel (for alternative wiring, barrier glands or stopper boxes must be used at both probe and transmitter entries).

Where conduit is used, the stopper box must not be more than 0.457 m (18 in.) from the enclosure (remote terminal housing or integral probe).

# Endura AZ30 Combustion oxygen monitor

## Probe cable connections – remote transmitter terminal housing to probe

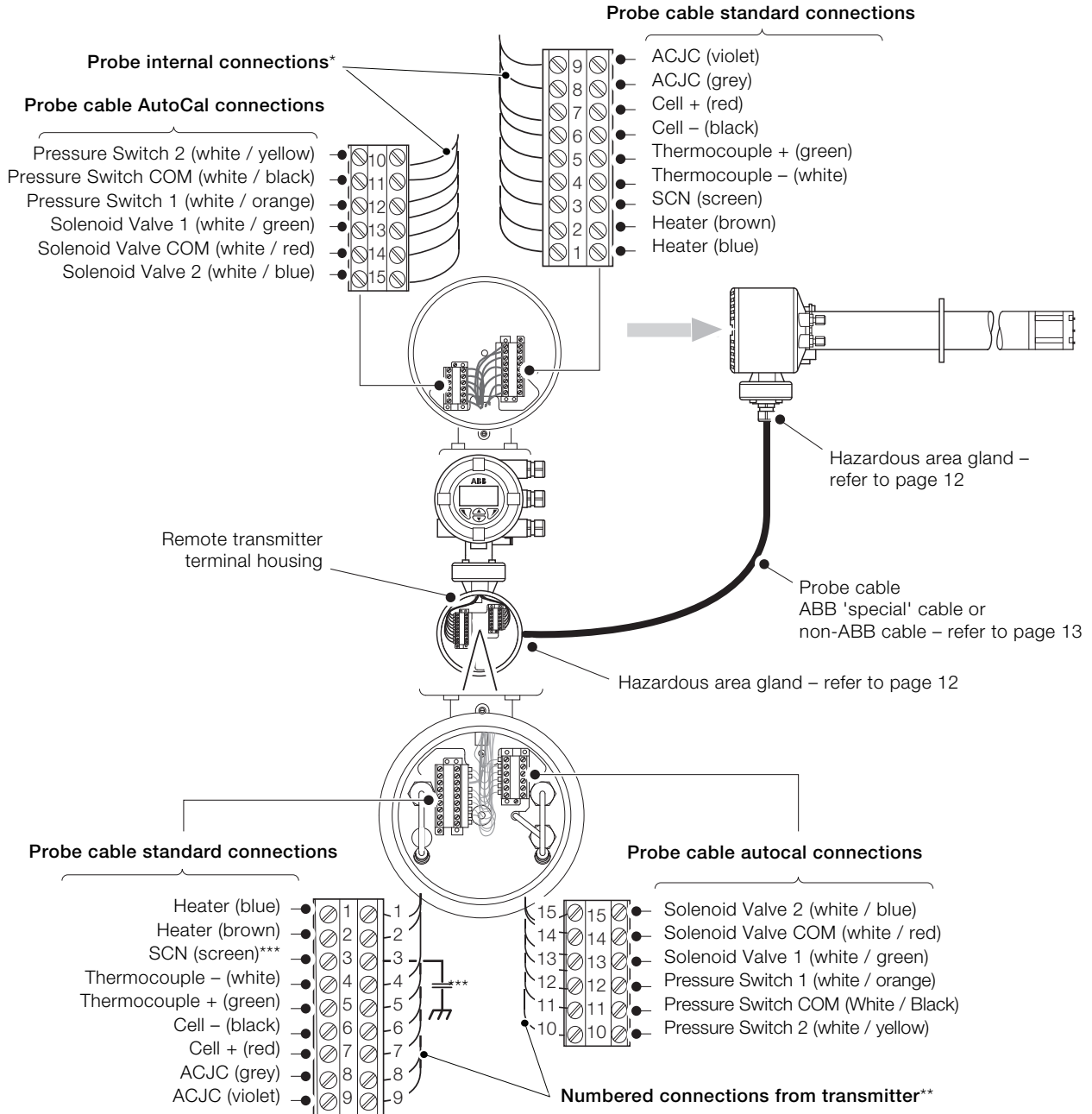

\*Probe internal connections already made at the factory.

\*\*Numbered connections from the transmitter to the transmitter's terminal housing already made at the factory.

\*\*\*Screens must be connected to terminal 3 in the remote terminal housing where they are earthed via a de-coupling capacitor.

Screens must not be connected directly to earth elsewhere.

## Transmitter power supply and output connections

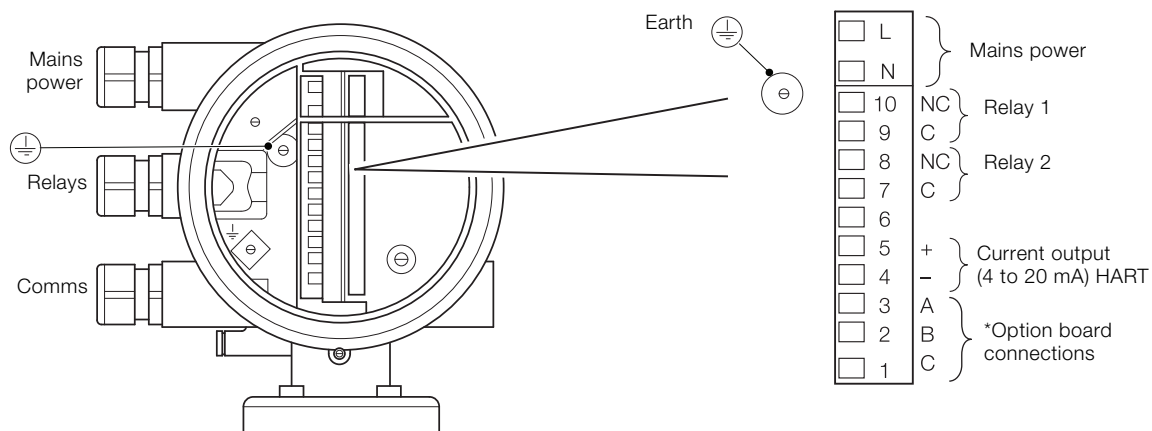

*Option board connections	A	B	C
Analog output	+	-	
Digital I/O	DIO1	DIO2	COM

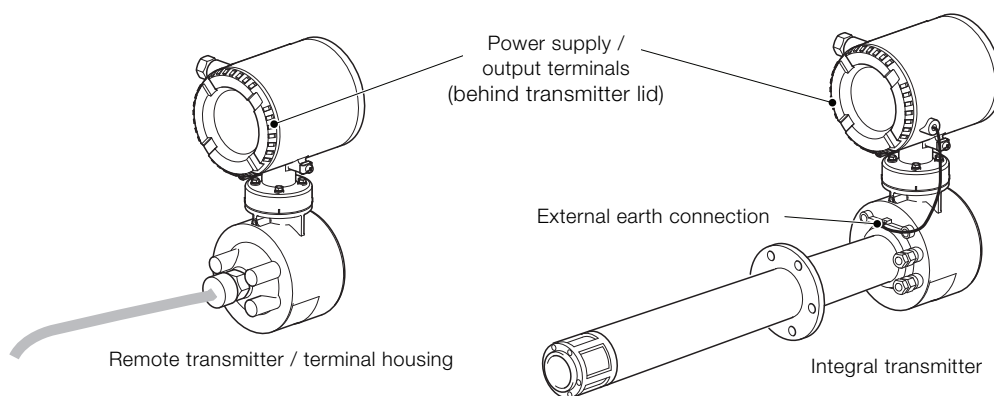

# Endura AZ30

## Combustion oxygen monitor

### System specification

#### Hazardous area certifications

##### ATEX and IECEx:

- Certified for use in Class I Zone 1 and Zone 2 – gas groups IIA, IIB + H2, Class II Zone 21 and Zone 22 – dust group IIIC

##### FM

- Certified for use in Class I Division 1 gas groups BCD, Class II Division 1 dust groups EFG

#### Measurement performance

##### Range:

- 0 to 20.95 % O<sub>2</sub> max. (condition of certification)

##### Test gas response time:

- initial dead time 3 seconds
- T90 < 10 seconds

##### System accuracy:

- < ±0.75 % of reading or 0.05 % O<sub>2</sub>

##### Drift:

- < ± 1 % maximum % O<sub>2</sub> range value per month (without calibration)
- < ± 0.2 % typical

#### Environmental data

##### Ambient operating temperature:

- transmitter: -20 to 55 °C (-4 to 131 °F)
- probe: -20 to 70 °C (-4 to 158 °F)  
(hazardous area certification is valid only between -20 to 70 °C [-4 to 158 °F])

##### Storage temperature:

- -40 to 85 °C (-40 to 185 °F)

##### Operating humidity:

- up to 95 % RH, non-condensing

##### Sunlight:

- store and operate out of direct sunlight

##### Ingress protection:

- probe (excludes process side of mounting flange) IP66 and NEMA 4X
- electronics enclosures (remote and integral) IP66 and NEMA 4X

#### Power supply

##### AC power supply:

- 100 to 240 V AC ±10 %  
(90 V min. to 264 V max.) 50 / 60 Hz
- Maximum current 1.2 A

##### Electronics:

- < 10 W

##### Probe heater:

- < 100 W

#### EMC

##### Emissions and immunity:

- conforms to EN61326-1:2006

#### Safety

##### General safety:

- conforms to EN61010-1: 2001

##### Approvals and safety certification:

- CE mark
- cFMus
- ATEX



## Probe specification

### Hazardous area certifications

- Ex II 2 GD
- Ex d IIB +H<sub>2</sub> T4 Gb (Ta -20°C to 70°C)
- Ex tb IIIC T135°C Db (Ta -20°C to +70°C) IP66
- Cert. No IECEx BAS12.0048X
- ATEX Cert No. Baseefa12ATEX0076X
  
- Class I Division 1 Groups BCD T4
- Class I Zone 1 AEx/Ex d IIB+H<sub>2</sub> T4
- Class II Division 1 Groups EFG T4 (Ta -20 °C to +70 °C) Type 4X
- Max Working Pressure 1.1bar absolute
- FM Certificate No. 3039243

### Physical

Probe insertion lengths:

- 0.5 m (1.7 ft.)
- 1.0 m (3.3 ft.)
- 1.5 m (5.0 ft.)
- 2.0 m (6.6 ft.)

Process connection:

- All probe lengths (flange pressure ratings do not apply):
  - ANSI B16.5 150 lb
  - 2, 2.5, 3, 4 in
  - DIN2501 Part 1
  - 65, 80, 100 mm
  - JIS B2238 5K

- 0.5 m (1.7 ft.) probes: ABB standard small flange
- 1.0 m (3.3 ft.): ABB standard large flange

Probe body material:

- 316 stainless steel

Mounting angle:

- Horizontal to vertically down

### Threaded entries

Gland entry (certified):

- probe cable gland entry: 1 x M25 or (optional) 3/4 in. NPT (remote probe only)

Pneumatic entries (not certified):

- 4 fittings supplied with AutoCal options or 3 fittings and 1 blanking plug supplied with non-AutoCal options. Size options: 1/4 in. BSP for 6 mm OD pipe (with M20 cable gland option) or 1/4 in. NPT for 1/4 in. OD pipe (with 1/2 in. NPT option)

### Automatic calibration

AutoCal hardware:

- optional built-in solenoid valves for control of test gas flow
- built-in pressure switches to detect presence of test gases

### Process conditions

Standard process temperature:

- all probe lengths -20 to 700 °C (-4 to 1292 °F)

Process:

- this probe is certified for use in non oxygen-enriched atmospheres, 0 to 20.95 % air only and a maximum pressure of 1.1 bar absolute (44 in. WG)

### Operating requirements

Reference air (clean dry instrument air free from oil):

- regulated supply: 1 bar (15 psi) ±12 %\*

Test gases – regulated to 1 bar (15 psi) ±12 %\*:

- user-selectable, 100 to 0.1 % O<sub>2</sub> balance N<sub>2</sub> and / or air (air is recommended as one of the test gases)

Calibration:

- manual, semi-automatic or automatic (controlled by Endura AZ30 transmitter)

### Heater operational requirements

Nominally 190 W, 70 W at 115 V AC – power is limited to 70 W max. by AZ30 transmitter over an 85 to 265 V AC range

\*Condition of certification

# Endura AZ30

## Combustion oxygen monitor

### Transmitter specification

#### Hazardous area certifications

Transmitter

-  II 2 GD
- Ex d IIB +H<sub>2</sub> T6 Gb (Ta –20°C to 55°C)
- Ex tb IIIC T85°C Db IP66 (Ta –20°C to 55°C)
- Certified component
- IECEx BAS12.0050U
- Baseefa12ATEX0078U

- Class I Division 1 Groups BCD T6
- Class I Zone 1 AEx/Ex d IIB+H<sub>2</sub> T6
- Class II Division 1 Groups EFG T6 (Ta –20 °C to +55 °C) Type 4X
- FM Certificate No. 3039243
- Max Current 1.2A

Remote terminal housing

-  II 2 GD
- Ex d IIB +H<sub>2</sub> T6 Gb (Ta –20°C to 70°C)
- Ex tb IIIC T85°C Db (Ta –20°C to +70°C) IP66
- Cert. No IECEx BAS12.0049X
- ATEX Cert No. Baseefa12ATEX0077X

- Class I Division 1 Groups BCD T6
- Class I Zone 1 AEx/Ex d IIB+H<sub>2</sub> T6
- Class II Division 1 Groups EFG T6 (Ta –20 °C to +70 °C) Type 4X
- FM Certificate No. 3039243

#### Transmitter enclosures

Remote transmitter (mounted to remote terminal housing):

- wall-, pipe- or stand-mounted (mounting bracket supplied)

Integral transmitter:

- head-mounted to probe

#### Physical

Remote transmitter:

- aluminium (EN AC44200 or 47000)

Remote terminal housing:

- 316 stainless steel

Integral transmitter:

- aluminium transmitter housing / stainless steel probe and terminal housing

#### Threaded entries

Gland entries (certified):

- power and signals gland entries:
  - 3 x M20 or (optional) 1/2 in. NPT
- remote terminal housing cable gland entry:
  - 1 x M25 or (optional) 3/4 in. NPT (remote system only)

Pneumatic entries (not certified):

- 4 fittings supplied with AutoCal options or 3 fittings and 1 blanking plug supplied with non-AutoCal options. Size options: 1/4 in. BSP for 6 mm OD pipe (with M20 cable gland option) or 1/4 in. NPT for 1/4 in. OD pipe (with 1/2 in. NPT option)

#### Automatic calibration

AutoCal hardware:

- isolated solenoid valve control as standard, 24 V @ 2 W per valve\*
- dedicated isolated digital inputs to monitor pressure switch contacts as standard: voltage-free, normally closed with gas present

#### Display and switches

Display type:

- graphical 128 x 64 pixel LCD

Display backlight

- green LED

Operator switches

- 4 capacitive switches (operated through the front glass)

\*For driving internal automatic calibration (AutoCal) probes or can be used to drive external calibration units on remote transmitters only.

## Relay outputs

Number:

—2 standard

Type:

—normally closed

5 A @ 230 V AC or 30 V DC (non-inductive)

Functions

User-configurable: can be activated by 1 or more of the following signals:

- process alarm 1, 2, 3, 4
- calibration in progress
- calibration failed
- out of test gas 1, 2
- test gas 1 valve control
- test gas 2 valve control
- failure diagnostic
- out-of-specification diagnostic
- maintenance required diagnostic
- function check diagnostic

## Digital inputs / outputs

Number:

—2 (optional)

Type:

—user-configurable as either input or output

Input:

—voltage-free contact

Output:

- transistor switch capable of sinking 220 mA
- low output, < 2 V DC
- switch voltage 30 V DC maximum

Isolation:

—not isolated from each other or from other circuitry

Input functions:

- user-configurable for:
  - automatic calibration start
  - automatic calibration stop
  - automatic calibration start / stop

Functions

—user-configurable, can be activated by one or more of the following signals:

- process alarm 1, 2, 3, 4
- calibration in progress
- calibration failed
- out of test gas 1
- out of test gas 2
- test gas 1 valve control
- test gas 2 valve control
- failure diagnostic
- out-of-specification diagnostic
- maintenance required diagnostic
- function check diagnostic

## Analog outputs

Standard:

- 1 isolated current output
- programmable to retransmit oxygen (linear or logarithmic) or temperature
- programmable over 4 to 20 mA
- over-range capability to indicate system failure programmable from 4 to 22 mA

Optional:

- 1 isolated current output
- programmable to retransmit oxygen (linear or logarithmic) or temperature
- programmable over 0 to 20 mA
- over-range capability to indicate system failure programmable from 0 to 22 mA

# Endura AZ30

## Combustion oxygen monitor

### Hart communications

Version:

- 5.7 as standard

Integration:

- Device Type Manager (DTM) and Electronic Device Description (EDD)
- provide online / offline device configuration, online monitoring of measurement values and diagnostic states

DTM

- FDT v1.2.1 compliant
- works with FDT framework packages (for example, ABB Asset Vision Basic)

EDD

- compliant with suitable framework tools (for example, SDC 625 and Simatic PDM tools)

### Infrared service port

Accessibility:

- through front face

Type:

- IrDA standard

Baud rate:

- up to 115 K baud

Functions:

- firmware update
- remote HMI
- diagnostic log download
- datalog output
- HART via IrDA

### Languages

- English
- French
- German
- Italian
- Spanish

### Calibration

Manual calibration

- 1 point (offset)
- 1 point (factor)
- 2 point (offset + factor)

Automatic calibration:

- 1 point (offset)
- 2 point (offset + factor)

Calibration control:

- front panel controls
- digital inputs
- HART commands
- user-defined schedule

Calibration scheduler:

- user-defined schedule enables automatic calibration frequency to be set from 1 day to 12 months

## Spares and accessories

### Documentation and software

Part number	Description
MI/AZ30M-EN	Maintenance Guide – download* from: <a href="http://www.ABB.com/analytical-instruments">www.ABB.com/analytical-instruments</a> *Enter this address in your browser and search <b>MI/AZ30M-EN</b> – the Maintenance Guide is the top link.
AZ30 DTM Software	Device Type Manager – contact ABB for details



### Transmitter spares

Part number	Description
AZ200 750	AZ30 Transmitter cartridge – Standard
AZ200 751	– Standard + Analog O/P
AZ200 752	– Standard + Digital O/P
AZ200 757	Transmitter backplane
AZ200 785	USB to IrDA adaptor kit

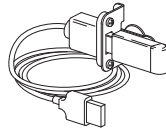

### Accessories

Part number	Description
AZ200 731	Coalescing filter-regulator* – 1/4 NPT 5 µm
AZ200 732	– 1/4 NPT 5 µm
	*Required for Reference air and Test Gas air

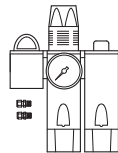

### Probe spares

Part number	Description
Length dependant – see below	Thermocouple / electrode assembly
<b>Probe length</b> 0.5 m (1.7 ft.) 1.0 m (3.3 ft.) 1.5 m (5.0 ft.) 2.0 m (6.6 ft.)	 <b>Part number</b> AZ200 701 AZ200 702 AZ200 703 AZ200 704
AZ300 745	Cell assembly – includes C-ring and Commissioning label
AZ200 727	Restrictor spares kit
AZ300 746	Diffuser flame arrestor assembly – includes C-ring
AZ200 798 AZ200 799	Probe tool kit* NPT (AZ30) BSP (AZ30)
	*Included with probe as standard

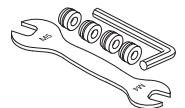
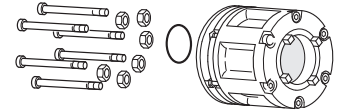
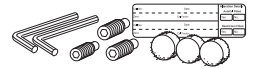
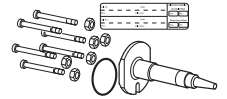

# Endura AZ30

## Combustion oxygen monitor

### Ordering information

Endura AZ30 probe / transmitterAZ30/	X	X	X	X	X	X	X	X	X	X	X	X	X	X	X	X	X	STD
<b>Transmitter options</b>																		
None	0																	
Standard	1																	
Standard + 2 <sup>nd</sup> analog output	2																	
Standard + 2 digital inputs / outputs	3																	
<b>Transmitter entry type</b>																		
None (no transmitter required)		0																
Metric (M20)		1																
Imperial (NPT)		2																
<b>Transmitter system type</b>																		
None (no transmitter required)			0															
Integral			1															
Remote			2															
<b>Probe type</b>																		
None (no probe required)				0														
Standard				1														
<b>Probe entry type</b>																		
None (no probe required)					0													
Metric (M20)					1													
Imperial (NPT)					2													
<b>Probe system type</b>																		
None (no probe required)						0												
Integral						1												
Remote						2												
<b>Automatic calibration</b>																		
None (no probe required)							0											
No automatic calibration							1											
Automatic calibration							3											
<b>Insertion length</b>																		
None (no probe required)								0										
0.5 m (1.7 ft.)								1										
1.0 m (3.3 ft.)								2										
1.5 m (5.0 ft.)								3										
2.0 m (6.6 ft.)								4										

Endura AZ30 probe / transmitterAZ30/		X	X	X	X	X	X	X	X	X	X	X	X	X	X	X	X	STD	
<b>Flange type</b>																			
None (no probe required)	0	ANSI 2.5 in flange		6															
ABB standard flange	1	ANSI 3 in flange		7															
DIN 65 mm flange	2	ANSI 4 in flange		8															
DIN 80 mm flange	3	JIS 65 mm flange		9															
DIN 100 mm flange	4	JIS 80 mm flange		A															
ANSI 2 in flange	5	JIS 100 mm flange		B															
<b>Thermocouple type</b>																			
None (no probe required)																			0
Type K																			1
<b>Cell options</b>																			
None (no probe required)																			0
Standard cell																			1
<b>Cable (excludes barrier glands)</b>																			
None																			0
5 m (16 ft.)																			1
10 m (33 ft.)																			2
25 m (82 ft.)																			3
50 m (164 ft.)																			4
75 m (246 ft.)																			5
100 m (328 ft.)																			6
<b>Cable type</b>																			
None																			0
STD																			1
CSA																			2
<b>Ex gland option</b>																			
None																			0
M25																			1
3/4 in. NPT																			2
<b>Certification option</b>																			
ATEX / IECEx																			1
FMus																			2
cFM																			3
<b>Language</b>																			
English																			E
German																			G
French																			F
Spanish																			S
Italian																			I

### Trademarks and Acknowledgements

HART is a registered trademark of the HART Communication Foundation

Microsoft and Excel are registered trademarks of Microsoft Corporation in the United States and/or other countries

# Contact us

## **ABB Limited**

### **Process Automation**

Oldends Lane  
Stonehouse  
Gloucestershire GL10 3TA  
UK

Tel: +44 1453 826 661

Fax: +44 1453 829 671

## **ABB Inc.**

### **Process Automation**

125 E. County Line Road  
Warminster  
PA 18974  
USA

Tel: +1 215 674 6000

Fax: +1 215 674 7183

[www.abb.com](http://www.abb.com)

## Note

We reserve the right to make technical changes or modify the contents of this document without prior notice. With regard to purchase orders, the agreed particulars shall prevail. ABB does not accept any responsibility whatsoever for potential errors or possible lack of information in this document.

We reserve all rights in this document and in the subject matter and illustrations contained therein. Any reproduction, disclosure to third parties or utilization of its contents – in whole or in parts – is forbidden without prior written consent of ABB.

Copyright© 2012 ABB

All rights reserved

3KXA722301R1001



Sales



Service



Software