

Predictive emission monitoring systems (PEMS)

Deploying software-based emission monitoring systems for refining processes



Gregorio Ciarlo and Federico Callero, ABB S.p.A., Italy, discuss the deployment of software-based PEMS in refining processes

Measurement made easy

Predictive emission monitoring systems (PEMS)

Introduction

In the process industries, legal requirements regulate the continuous acquisition of emission data to monitor and control pollutants released into the atmosphere. Data verifies that plant emissions do not exceed law-enforced thresholds. From a plant owner's perspective, it's important that efficient and reliable tools for acquiring emission data are available. Environmental constraints not only can affect production, but failure to provide emission values for extended periods may lead to an authority imposed plant shutdown.

Typical plant continuous emission monitoring systems (CEMS) are essentially hardware-based. They normally include analyzers (to sample and identify the compositions of released flue gas) and an IT infrastructure (to manage, record and store the emissions values^[1]).

Software-based predictive emission monitoring systems (PEMS) represent an alternative, accepted by several environmental regulations^[2], for monitoring and recording air pollutant emissions. PEMS is an innovative technology able to estimate emission concentrations through advanced mathematical modeling techniques.

Among the different techniques, empirical (also referred as data-driven or inferential) modeling is recognized as the most effective in creating accurate models for estimating emissions.

This approach exploits the capability to extract relevant information from historical datasets and predict the behavior of the pollutant concentrations based on the physical variables characterizing the emission-generating process itself.

...Introduction

In particular, Artificial Neural Networks (ANN) have the flexibility to balance between model performance and robustness^[3], providing accuracy and reliability comparable to hardware-based emission analyzers. This paper describes a successful implementation of neural network technology at a major refining plant in Southern Europe.

For more information

Further details of ABB Measurement & Analytics products are available for free download from:

www.abb.com/measurement

or by scanning this code:



PEMS rationale and process overview

While US-EPA legislation recognizes the possibility of adopting PEMS as the primary source for emission monitoring, European regulation allows the usage of PEMS mainly as a back-up of traditional CEMS.

Given the regulating framework, a major European oil refinery decided to implement PEMS in order to back-up the existing CEMS-based emission monitoring infrastructure. Main purposes of the application were increasing above 97.5 % the service factor of the hardware analysis system and limiting the number of interventions of a third party company to monitor the emissions during off-service periods of the hardware analyzers.

PEMS application has been designed to provide the refinery with redundant values of different pollutant components (i.e. SO₂, CO, NO, O₂, flue gas flowrate and particulate) from two key areas of the plant: the fluid catalytic cracking (FCC) and the sulfur recovery units (SRUs).

This was a very challenging application, since the involved units are much more complex than those generally deemed as the most suited for PEMS implementation (e.g. gas turbines, boilers, etc.).

Furthermore, at this refinery, traditional SRUs and FCC units have been upgraded and modified in order to increase the refining capacity and limit the emissions.

SRUs

The SRU stack collects the exhaust gases coming from three parallel desulfurization trains, each characterized by different treatment technologies and process units – downstream three virtually identical Claus processes. The trains are equipped with a number of bypass valves that enable the process gas to be diverted among them as required – see Figure. 1:

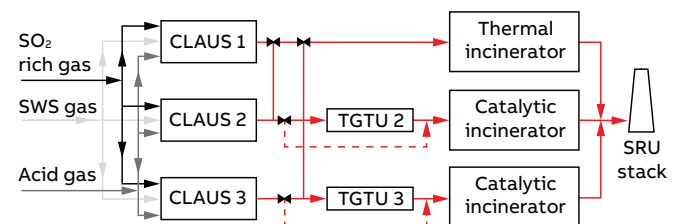

Figure. 1 SRUs layout

The second and third trains each have different, patented tail gas treatment units (TGTU) followed by a catalytic incineration stage. The first unit has only a thermal incinerator that allows a less efficient sulfur removal. Gases sent to the SRUs come from different refinery treatments and production units. The composition and ratios of these gases are neither well known nor fixed over time: essentially, the feed comprises three streams rich with H₂S, CO₂ and NH₃ in variable concentration.

FCC

A patented absorption process has been commissioned to further treat the flue gas from the FCC regenerator, reducing the SO_2 released into the atmosphere. This new unit is equipped with its own stack (FCC-02) – see Figure 2:

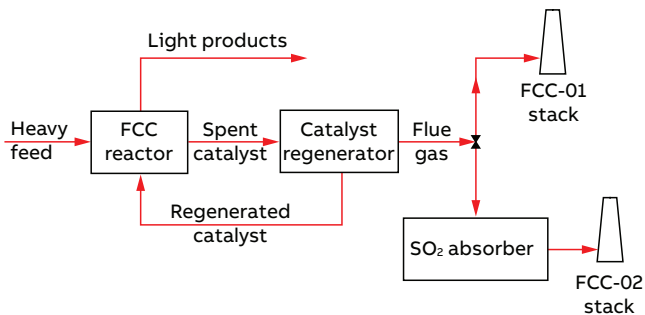

Figure. 2 FCC and absorption units layout

A valve can divert the exhaust gas from the cracking unit to the absorber or directly to the original stack (FCC-01).

Plants layout and processes involved provide several complexities on the implementation of an effective predictive solution. A first complication came from the highly variable composition of the feeds which is not under operator control and strictly dependent on the performances of the upstream units and on the initial hydrocarbons processed by the refinery.

The other critical point results from the large number of possible different operating scenarios for both units:

- The different sub-processes involved in the SRUs can be operated in a number of configurations, depending on load variations and maintenance activities that generate very different emission levels.
- The SO_2 absorption unit is often used in order to comply with environmental constraints. When active, up to 50 % of the FCC off gases divert to the SO_2 absorber and then to the FCC-02 stack. When the SO_2 absorption unit is inactive, all the gases enter the FCC-01 stack.

These operating challenges had a huge impact during the engineering phase and required a deep analysis of process behavior and a close cooperation with plant personnel in order to properly assess unit operations and available instrumentation.

PEMS solution

The collaboration with refinery engineers allowed the PEMS team to define the standard operating conditions that should be considered for system development. For the SRUs, PEMS application was tailored to provide the best performances in the most common scenario, which is also the one that allows the highest sulfur removal efficiency: TGTU2 and TGTU3 both operating with the tail gas from the first unit diverted to TGTU2.

Concerning the cracking unit, software analyzers were developed in order to provide an accurate measurement for both stacks, using the valve open-position value to identify possible shutdown of the SO₂ absorber.

The key requirement for effective model building is the creation of a representative dataset – a set of variables that describes process dynamics and covers all the standard operating conditions. Therefore, the first step of the project was a data-collection phase, aimed at gathering a baseline of synchronized, time-stamped emission and process data suitable for model creation: six month data archived in the plant historian and in the emission data acquisition system were extracted and analyzed.

The initial dataset was processed in order to finalize the subset of variables to be used for model development, performing a number of operations:

- The removal of outliers and ‘bad quality’ data.
- The identification of the proper sampling time in order to balance between the model overtraining and the loss of important information on process variability.
- The statistical analysis through advanced mathematical techniques, such as principal component analysis, to draw out also the hidden correlations between process parameters and emission values.

With the above-mentioned activities, PEMS engineers have been able to choose the operating parameters most indicated to be used as input variables. Given the large number of units involved, SRU models required, on average, a set of 10 to 12 input parameters to ensure proper accuracy, while models for the cracking unit needed just seven or eight input variables. Several different model structures (partial least squares, linear regressions, genetic algorithms, neural networks, etc.) have been generated and their performances have been compared in order to identify the model which was able to reproduce more accurately emission values. After this evaluation, the team picked feed forward neural networks as the model architecture since it proved to be the most robust and effective for monitoring emissions.

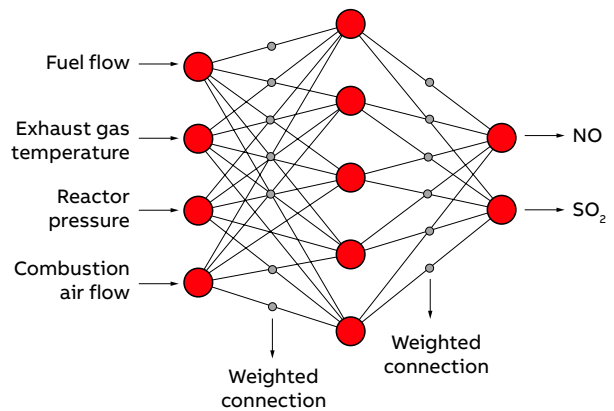

Figure 3 Feed forward neural network schematic

After the off-line validation, software analyzers were installed on-site in a dedicated server. An OPC connection was established in order to make the real-time process values from the control system available to the PEMS software engine. This module processed the parameters within the models in order to produce real-time emission estimations.

The team engineers then integrated the PEMS system with the existing emission data acquisition system (DAS) to make it accessible to plant personnel – see Figure 4:

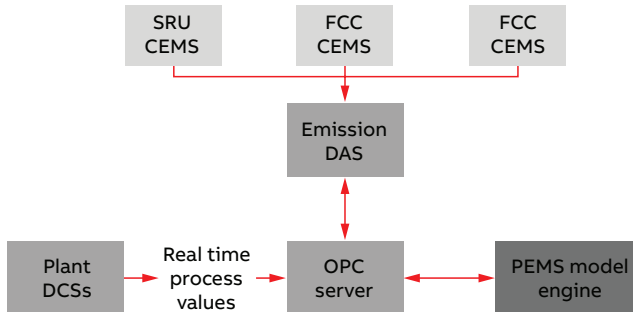

Figure. 4 System architecture schematic

They implemented a strategy to employ PEMS values for the refinery's emission 'bubble' limit when data from the traditional instrumentation was not available.

Results

In order to validate PEMS estimations and have the final acceptance by the refinery, engineers performed a comparison between the values produced by the system and measurement by the existing hardware instrumentation. This analysis showed that predictions from software analyzers aligned very well with analytical devices: Figure 5 charts predicted SRU flow values against real-time data obtained from the flowmeter mounted at stack

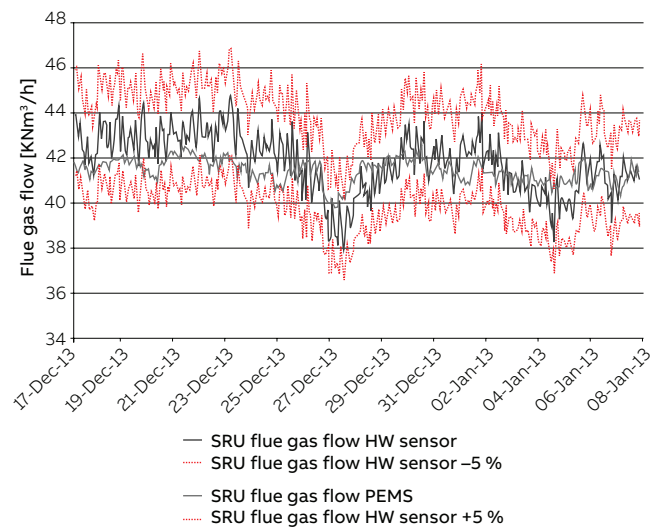

Figure. 5 PEMS vs CEMS for flue gas flow at SRU stack

Figure 5 shows that PEMS values are well aligned and fall within the $\pm 5\%$ bandwidth from the physical measurement in the 20-days period reported. PEMS implementation was particularly important in order to increase the total availability of the emission monitoring infrastructure at site. During normal maintenance on the hardware CEMS, redundant measurements provided by the inferential models were able to cover the blank periods.

...Results

Figure 6 presents a daily chart showing predicted and measured NO emission values at FCC stack:

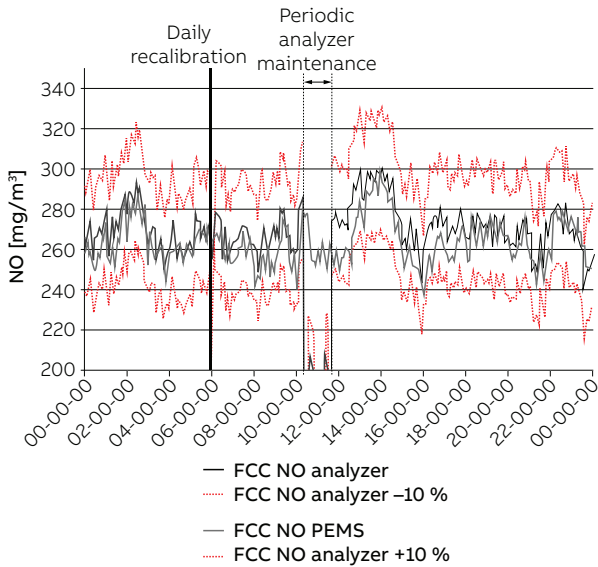

Figure. 6 PEMS extends emission monitoring availability

Due to daily automatic re-calibration and a periodic maintenance activity, emission measurement from hardware analyzers were not available in two separate intervals (one of which lasted around one hour).

Thanks to the PEMS model, an alternative measurement was available and the overall service factor of the emission monitoring infrastructure was raised well above 99 %.

Conclusions

Software analyzers proved to be a highly accurate solution capable of acting as a reliable back up to the traditional CEMS in very challenging refinery processes. In such applications, any discrepancy between the PEMS model output and the analytical measurement can serve as an early warning of measurement drift or malfunction of the hardware devices to trigger maintenance. PEMS can also represent a benchmark to validate maintenance actions.

Predictive systems also provide an inherent advantage not given by traditional hardware-based CEMS: the availability of a well-trained inferential model allows plant operators to perform off-line simulations of emission behavior at varying operating conditions. Thanks to this unique ‘what-if’ analysis, plant engineers can investigate how emissions respond to changes in input variables and the role of each operating parameter in final emission values.

PEMS extend their contribution well beyond the CEMS back-up role. In fact, such systems have been successfully implemented as primary monitoring technology in thousands of applications, further demonstrating their capability to offer accuracy and performance equivalent to conventional analyzers^[4] and also a larger data availability which approaches DCS’s one (typically very close to 100 %).

Also from an economic perspective, PEMS usage provides a number of benefits when compared to traditional analyzers^[5], starting from the initial investment (CAPEX) that is usually considerably lower than hardware-based solutions. But it is in assessing operating costs that the PEMS advantage catches end-user Purchase Department’s eyes.

In fact, PEMS enjoys some very advantageous features like:

- Not requiring any specific preventive or periodic maintenance program.
- Almost no power consumption.
- No need for any consumables and spare parts, minimizing warehouse necessities.

Including these and other benefits, it is possible to see how the overall life cycle cost in five years could be reduced up to 50 % compared to conventional hardware-based systems.

In summary, the present paper has showed how advanced software technologies are able to deliver excellent results in environmental projects. This does not mean that these systems are going to replace CEMS: depending on process layout, equipment and operative conditions one of the two approaches may provide better results and should be preferred. Ideally, an effective solution portfolio should include both software and hardware-based emission monitoring strategies, so to be able to cover the whole range of possible applications.

For example, PEMS may have an edge when applied to boilers, gas turbine or furnaces while conventional CEMS are to be preferred when dealing with units, such as civil incinerators or where solid fuels are burnt.

Because engineering judgment becomes of essence, it is crucial to rely on a supplier with sound competencies and background in both approaches and able to provide effective guidance, acting as an advisor in order to identify the proper emission monitoring technology for the specific application.

References

- 1 Arioni, E., Bonavita, N., Paco, M. 'Keeping an eye on emissions', Hydrocarbon Engineering, pp 43-47, October 2013.
- 2 'Continuous Emission Monitoring Systems for Non-criteria Pollutant', EPA Handbook August 1997
- 3 Meireles, M.R.G, Almeida, P.E.M., Simões, M.G. 'A Comprehensive Review for Industrial Applicability of Artificial Neural Networks', IEEE Transactions on Industrial Electron-ics, Vol.50, No.3 pp 585-601, June 2003.
- 4 Bonavita, N., Callero, G. 'Model-based emission monitoring', ABB Review ¾11 pp 58-63, 2011
- 5 Roth, M., Lawrence, P. 'A cost-effective alternative to continuous emission monitoring systems', Air Pollution, pp 56-57, May 2010.

The authors



Gregorio Ciarlo | ABB S.p.A., Italy



Federico Callero | ABB S.p.A., Italy

ABB S.p.A.
Measurement & Analytics

Via Luigi Vaccani 4
22016 Tremezzina (CO)
Italy
Tel: +39 0344 58111
Email: abb.instrumentation@it.abb.com

abb.com/measurement



We reserve the right to make technical changes or modify the contents of this document without prior notice. With regard to purchase orders, the agreed particulars shall prevail. ABB does not accept any responsibility whatsoever for potential errors or possible lack of information in this document.

We reserve all rights in this document and in the subject matter and illustrations contained therein. Any reproduction, disclosure to third parties or utilization of its contents – in whole or in parts – is forbidden without prior written consent of ABB.

©ABB 2019
All rights reserved.