

# PumpFit

Finds the number of running pumps with lowest total electricity consumption

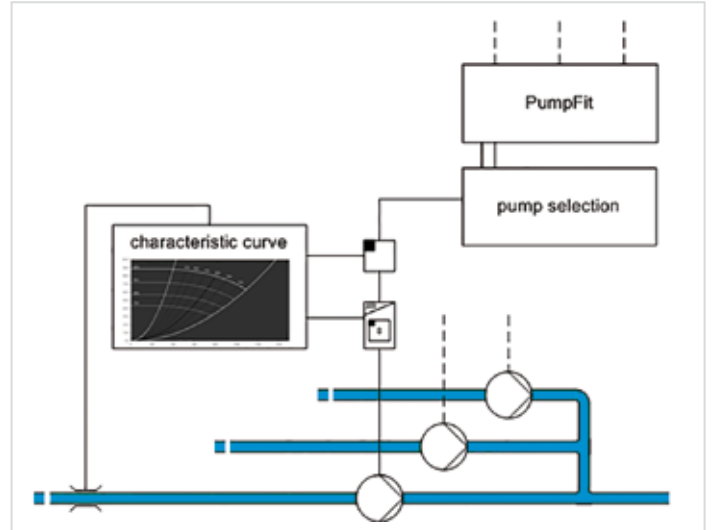

1 District heating pumps | 2 Control hierarchy



ABB's PumpFit expands the automation of variable speed pump groups to always find the optimum number of running pumps for lowest electrical power consumption.

**PumpFit optimizes the operation of pump groups, for instance in water pumping stations or in district heating networks. PumpFit is a control solution expanding the usual automation of variable speed pump groups to always operate the pumps within the actual upper and lower flow limits and NPSH and to always find the optimum number of running pumps for lowest electrical power consumption. PumpFit automatically aligns all pumps operation hours.**

### Challenge

Operators are responsible to operate the pumps efficiently always within the upper and lower flow limits and with sufficient NPSH.

Sometimes the control system does not even provide the actual flow value or total operating hours in order to support the operator.

Usually the control system displays the pump's upper and lower flow limits and the NPSH, all just valid for full pump speed, as plain values.

### Solution

PumpFit calculates all actual limits depending on the pump's actual speed and head for a fully automatic pump protection. PumpFit automatically runs all pumps within the upper and lower limits and NPSH.

Before taking a decision on start and stop of pumps, PumpFit checks that after fulfilled start/stop the pumps again will run within all limits. PumpFit also provides a detailed mimic display with the pump's characteristic curve, the actual operating point and the behavior of the past hours including the actual overall efficiency and power consumption. This information is available even if PumpFit is not activated.

The operators decide to run a pump manually or exclude a pump from the optimization.

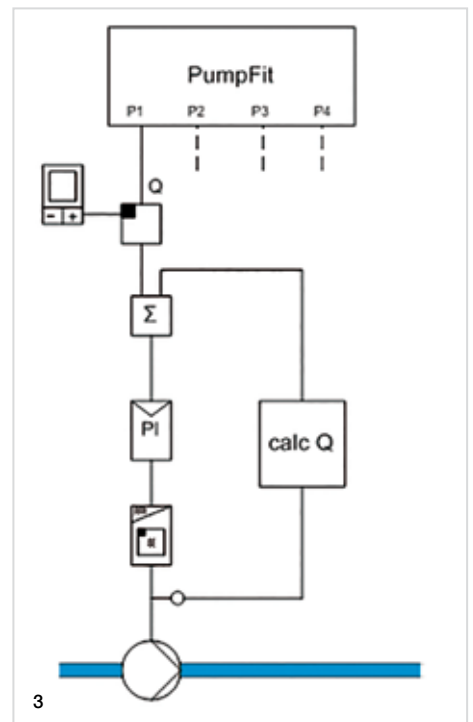
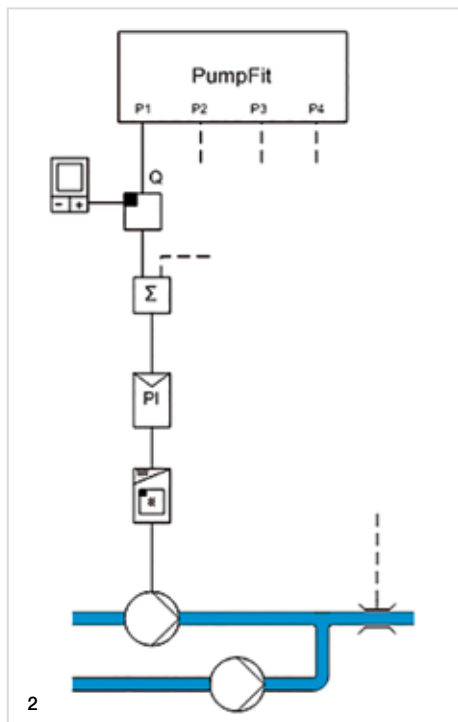
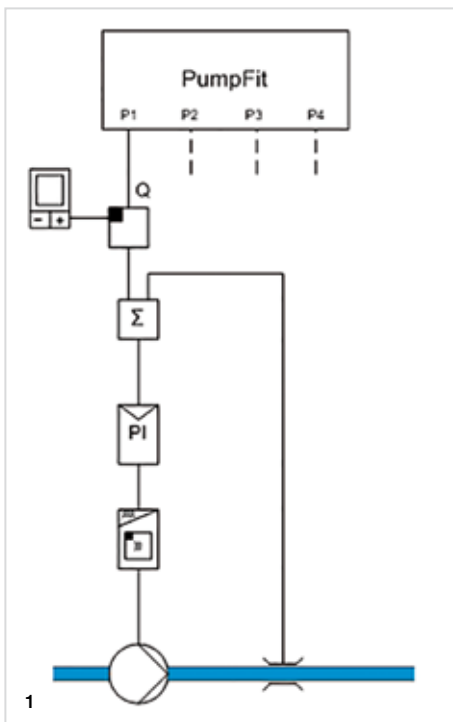

1 Each pump equipped with flow measurement | 2 Pump system equipped with one flow measurement | 3 Pumps without flow measurement

### Platform

ABB's PumpFit is programmed directly into the controller application software. PumpFit is operated from regular process mimics. No additional soft- or hardware is needed.

### Services

ABB takes over complete turnkey responsibility for engineering, installation, training, commissioning and support.

### Variable speed pump groups configurations

Variable speed drives (frequency converters) enable an efficient flow control by adjusting the pump speed instead of throttling a control valve. Usually a pump system includes more than one pump for several reasons.

Pump systems of 1 x 100 % or 2 x 100 %:

- A 2 x 100 % system includes a backup pump for increased availability.
- PumpFit automatically runs one pump within the upper and lower limits and NPSH.

Pump systems of 3 or more similar pumps:

- A system of 3 or more similar pumps includes one or more backup pumps and allows e.g. one pump operation during low load situations. E.g. for a 3 x 50 % group operating in the range of approx. 30 to 50 % of nominal flow it is often the operator's decision to run 1 or 2 pumps.
- PumpFit automatically runs all pumps within the upper and lower limits and NPSH.
- PumpFit always finds the optimum number of running pumps for lowest electrical power consumption.

### Individual pump configurations

Each individual pump is equipped with a dedicated flow measurement (image 1).

Each individual pump is not equipped with a dedicated flow measurement. The total pump system common header is equipped with one flow measurement (image 2).

No flow measurements are available (image 3).

In all three cases PumpFit calculates the flow for each individual pump using the pump electrical power and speed measurement.

- In case of a) this calculated flow is used as a backup of the flow measurement.
- In case of b) the calculated flow is used at all times and corrected by the overall flow measurement of the pump group.
- In case of c) the calculated flow is used at all times and adds up to the calculated overall flow of the pump group.

PumpFit uses the measured or calculated flow to control the pump flow. With the ability to calculate the flow, PumpFit can be used in nearly every setup without additional hardware.

### Control hierarchy

PumpFit is programmed on top of an automatic pump selection function block.

The pump selection automates e.g.

- Start/stop one pump, when triggered externally
- In case of trip of a running pump, start reserve pump

The operator sets PumpFit into automatic/off and PumpFit decides to trigger the automatic pump selection, when needed.



1 Mimic display | 2 Pumps running with and without PumpFit

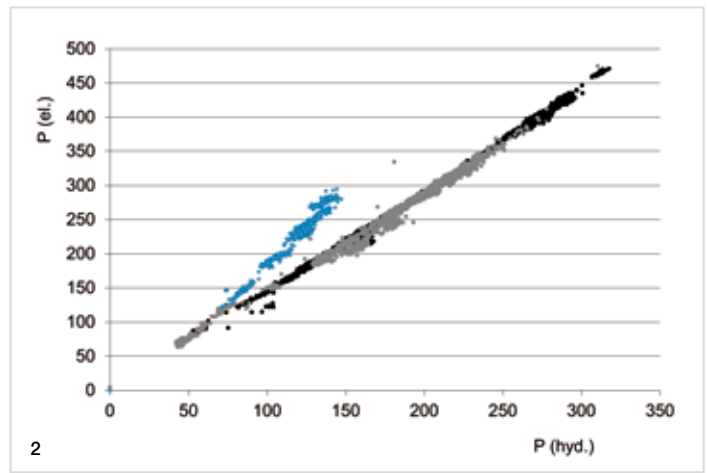

### Mimic display

The detailed mimic displays the pump's characteristic curve, the actual operating point and the behavior of the past hours including the actual overall efficiency and power consumption.

### Energy optimization

PumpFit enables the energy optimized control of pump groups. Exploiting given pump characteristics, the overall efficiency is calculated online for different possible scenarios. The best scenario is automatically selected and applied to the actual control.

### Operating hours

While choosing the optimal scenario PumpFit also takes the operating hours of each pump into account. When activating a pump, the pump with the lowest number of operating hours is used. When shutting down a pump, the pump with the highest number of operating hours is used. The result is an evenly distributed number of operating hours.

### Savings

Chart 2 shows a case of two pumps running with and without PumpFit, electrical power consumption over delivered hydraulic power. Every dot represents 10 minutes, in total 20 days are plotted. The grey and orange dots represent the pump group operating without PumpFit and the black dots operating with PumpFit. The orange dots show points of less efficiency caused by a poor choice of pumps. PumpFit takes the optimal number of pumps instead running at a higher efficiency.

### Benefits of PumpFit

- PumpFit always finds the optimum number of running pumps and reduces electrical power consumption.
- PumpFit automatically runs all pumps within the upper and lower limits and NPSH. This releases operators from monitoring, decisions and manual operation. At the same time this improves pump protection significantly.
- PumpFit calculates the flow of the individual pumps and of the pump group. In case these flow measurements are missing, PumpFit provides additional useful information to the operators.
- PumpFit automatically aligns all pumps operation hours.
- PumpFit provides additional formatted visual information for the operator to simplify monitoring.

### References

[District heating system Düsseldorf Flingern, Germany](#)

3 pumps, 800 m/h, 7 bar, 220 kW each

[District heating system Düsseldorf Garath, Germany](#)

3 pumps, 600 m/h, 4 bar, 100 kW each

For more information please contact:

**ABB AG**

**Power Systems Division**

P.O. Box 10 03 51

68128 Mannheim, Germany

Phone: +49 621 381-3000

Fax: +49 621 381-2645

Email: [powertech@de.abb.com](mailto:powertech@de.abb.com)

[www.abb.com/powergeneration](http://www.abb.com/powergeneration)

**Note:**

We reserve the right to make technical changes or modify the contents of this document without prior notice. With regard to purchase orders, the agreed particulars shall prevail. ABB AG does not accept any responsibility whatsoever for potential errors or possible lack of information in this document

We reserve all rights in this document and in the subject matter and illustrations contained therein. Any reproduction, disclosure to third parties or utilization of its contents – in whole or in parts – is forbidden without prior written consent of ABB AG.

Copyright© 2013 ABB

All rights reserved