

Seeing through switchgear

Radiographic inspection saves costs and downtime and enables better maintenance planning

JERRY MICHAELSON, ANDREAS MOGLESTUE – Ever since its discovery almost 120 years ago, radiography has both been both a source of fascination and a valuable tool. The stark and almost spooky grayscale photographs of our bones that we see in the hospital provide an unparalleled insight into the insides of the living body. Just as humans must sometimes visit the physician, so does switchgear require a periodic inspection. Both types of exams are there to pinpoint the causes of ailments, or proactively identify measures to prevent them. And there the somewhat superficial likeness ends. Or does it? Switchgear may not need to provide blood samples or take pills and have vaccinations, but that doesn't mean there is nothing that switchgear service cannot learn from medicine. When physicians use radiography to look inside the body, it means they do not need to use scalpels. For the patient this reduces pain, risk, costs and time. These same advantages also apply to switchgear. Equipment can be inspected without dismantling. Downtime and costs are minimized and the risk of contributing further errors or causing damage in reassembly is removed.

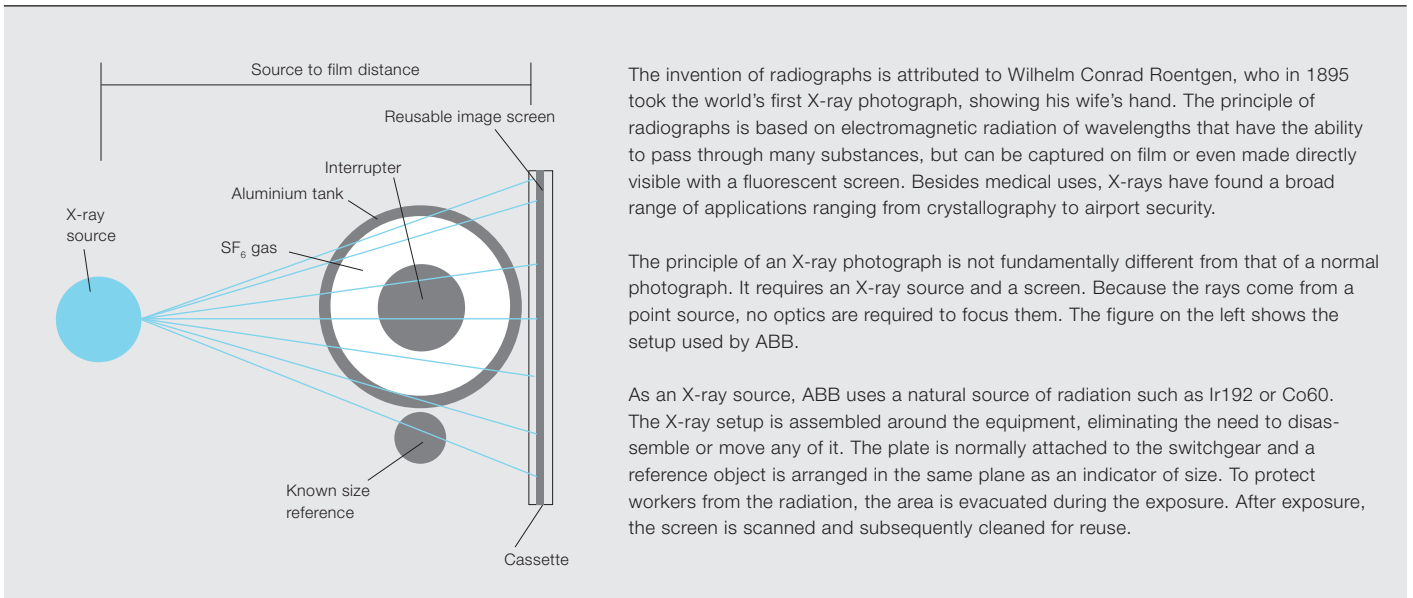

The invention of radiographs is attributed to Wilhelm Conrad Roentgen, who in 1895 took the world's first X-ray photograph, showing his wife's hand. The principle of radiographs is based on electromagnetic radiation of wavelengths that have the ability to pass through many substances, but can be captured on film or even made directly visible with a fluorescent screen. Besides medical uses, X-rays have found a broad range of applications ranging from crystallography to airport security.

The principle of an X-ray photograph is not fundamentally different from that of a normal photograph. It requires an X-ray source and a screen. Because the rays come from a point source, no optics are required to focus them. The figure on the left shows the setup used by ABB.

As an X-ray source, ABB uses a natural source of radiation such as Ir192 or Co60. The X-ray setup is assembled around the equipment, eliminating the need to disassemble or move any of it. The plate is normally attached to the switchgear and a reference object is arranged in the same plane as an indicator of size. To protect workers from the radiation, the area is evacuated during the exposure. After exposure, the screen is scanned and subsequently cleaned for reuse.

Inspecting switchgear the traditional way is not a simple matter. First of all, downtime has to be planned and coordinated. Before humans can approach the equipment, it must be disconnected and earthed. Breakers filled with SF₆ have to be degassed (and because SF₆ is a potent greenhouse gas, it should not be released into the atmosphere but collected and recycled). Then begins the actual dismantling and subsequent reassembly. This phase brings with it the risk that human errors can introduce defects that were not previously present. Parts can be lost, damaged or incorrectly fitted and debris can enter the equipment. Disassembly for inspection is time consuming and costly, and not always effective.

In view of the importance of switchgear in the delivery chain of electrical energy, utilities cannot afford not to inspect their switchgear regularly. An unexpected malfunction can cause blackouts and thus lost productivity and damage to the economy. At the same time, in order to plan maintenance and replacement effectively, knowledge of the condition of switchgear is vital.

Enter radiography. With radiographic inspection, ABB can see inside equipment without having to disassemble it. Just as with the manual inspection described above, the switchgear must be taken out of service, disconnected

and earthed. But the subsequent steps and overall downtime are replaced by the far simpler and much less invasive setting up of radiography equipment → 1. Time savings achieved means downtime is reduced from days to hours → 2.

Combined with operational diagnostics (precise measurement response times to infer the degree of wear of contacts), radiography can provide a low-cost yet effective way of obtaining detailed information on the condition of equipment and for predicting the remaining number of operating cycles before intervention is required.

A comparison between radiographic images and a diagram are shown in → 3. Examples of the level of detail such images can provide is shown in → 4. Experts can use such images to measure parts that are subject to wear. An “in spec” nozzle is compared with an “out of spec” one in → 5.

Besides problems associated to wear, radiography can also reveal manufacturing defects. In → 6, a detached screw can be seen, and in → 7, a bolt is incorrectly inserted.

Case study: Call Henry Inc. and NASA

Call Henry Inc. is the high-voltage on-site service contractor at the NASA Glenn Research Center in Cleveland, Ohio in the United States. The center

With radiographic inspection, ABB can see inside equipment without having to disassemble it

Title picture

Looking inside a breaker with radiography

2 Typical time savings achieved with radiography

Circuit breaker type	Outage times	
	Traditional invasive internal inspection	Radiography
38 – 145 kV	2 days	2 hours
242 kV	3 days	3 hours
362 kV	4 days	3 hours
550 kV	5 days	4 hours

3 Comparison of radiographic images and a diagram of a 38/72 PM interrupter

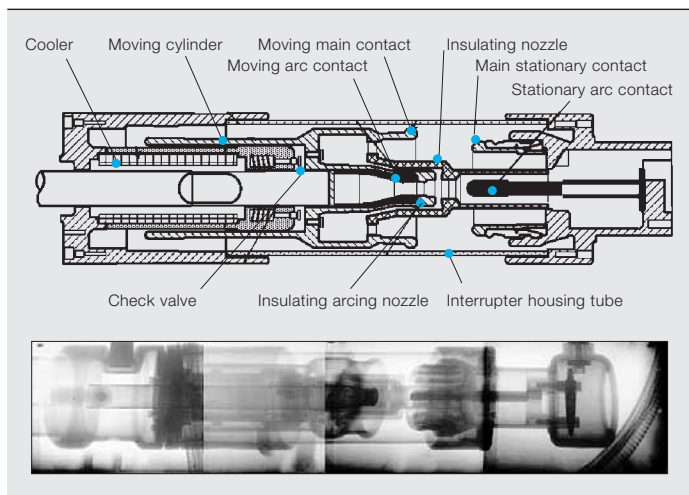

4 Examples of details revealed by radiography



5 Comparing a “good” and a “bad” nozzle

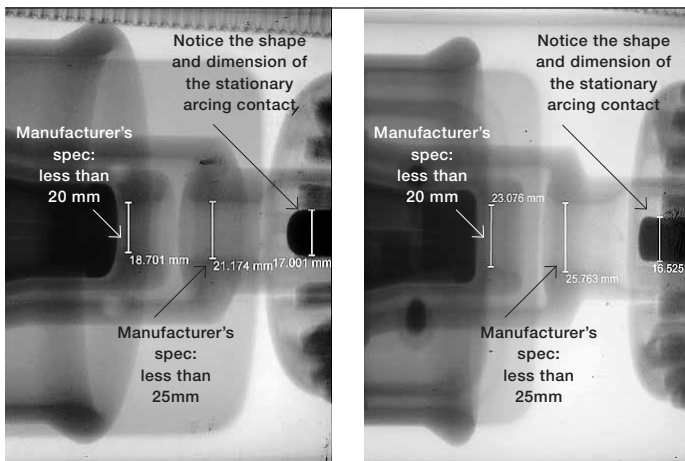

5a Nozzle in spec

5b Nozzle out of spec

Downtime is reduced from days to hours.

leads NASA's R&D in aeropropulsion, and specializes in turbomachinery, power propulsion and communications, while also leading research in the microgravity science disciplines of fluid physics, combustion science and the fields of microgravity acceleration measurement. The reliability of the power supply is vital for the center's operations. A review of the switchgear revealed that many of the center's circuit breakers were 10 to 14 years old, with one having completed 2,700 operations during its lifetime.

In February 2006, Call Henry Inc. contacted ABB on behalf of the research facility regarding the health of 26 ABB type 38PM40-20 SF₆-filled circuit breakers. With regard to reducing costs and downtime, it was decided to conduct external diagnostics testing and radiographic inspection. As a result of these tests, of the 26 breakers radiographed:

- One required entry to remediate a hardware problem.
- Seven required reduction of the SF₆ gas moisture content.

6 Detached screw

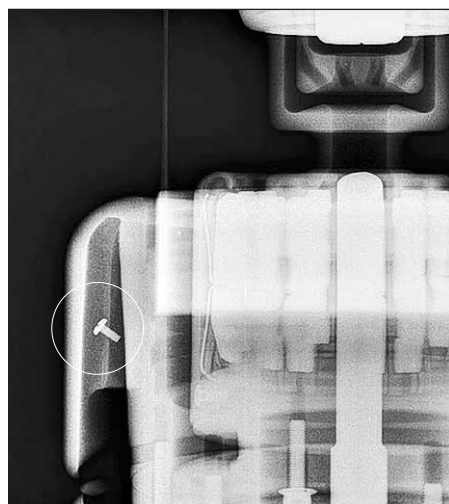

- 19 were spared entry and intrusive maintenance.

Overall, 38 man-days of intensive, internal inspections were saved. After performing the external diagnostic testing and resulting maintenance, NASA's fleet was restored to reliable operating status for less than 50 percent of the cost of traditional maintenance.

7 Incorrectly inserted bolt (note gap between disk and casing)

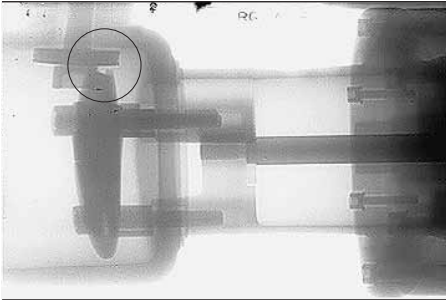

7a An area of concern

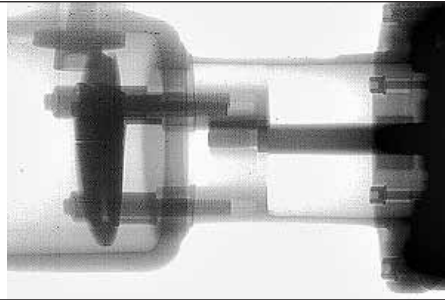

7b Correct bolt

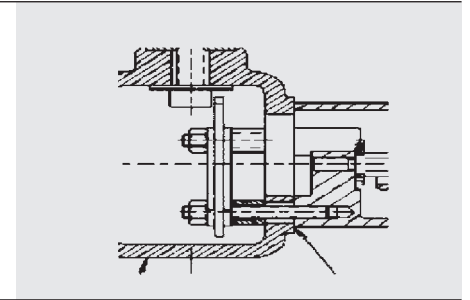

7c Reference drawing

Case study: Pacific Northwest

ABB was asked to perform radiographic inspections of eight ABB breakers for a Pacific Northwest utility in the fall of 2006. Shortly before the inspection, the utility had removed a Westinghouse 262SFA breaker from service. An inspec-

respect to traditional internal inspections.

Radiography is the tool

These and other examples show that radiographic inspection saves both time and money, both by reducing the amount

of work needing to be done when compared with traditional invasive inspection, and in terms of disruption and downtime for the customer. ABB can perform radiography on both equipment of its own manufacture

ABB can perform radiography on both equipment of its own manufacture and on the products of other and legacy manufacturers.

tion of the removed breaker revealed that the orifice on one contact was broken and that the guide rings from four others had become detached and were lying at the bottom of the tank. This situation posed the possibility of a catastrophic circuit breaker failure. Increasing the risk was the fact that the broken part turned out not to be an OEM¹ component but a reverse-engineered non-OEM one (ABB took over the transmission and distribution activities of Westinghouse in 1989 and continues to supply OEM parts).

and on the products of other and legacy manufacturers, and has the expertise to evaluate the photographs and provide service advice on the basis of this.

Five further breakers of the same design were thus inspected by ABB using radiography. Based on the findings and a review by a Westinghouse expert, it was determined that one of these breakers had no less than three broken orifices. One phase was missing both orifices and one phase was missing one. If this breaker were called on to perform a full-fault interruption, a failure would be likely. The other breakers were found not to be in need of immediate repair. This operation saved the customer \$60,000 with

Jerry Michaelson

ABB High Voltage Products
Nashville, TN, United States
jerry.michaelson@us.abb.com

Andreas Moglestue

ABB Review
Zurich, Switzerland
andreas.moglestue@ch.abb.com

Footnote

1 OEM: Original equipment manufacturer