



Peak performance

Root cause analysis of plant-wide disturbances

Alexander Horch, John Cox, Nunzio Bonavita

Disturbances and oscillations in production processes usually have a considerable effect on product quality, running costs and profitability because production and throughput may have to back away from their optimum settings to accommodate process variability.

An international research and development team has developed an innovative solution for plant-wide disturbance analysis. After extensive field testing and collection of requirements, a Plant-wide Disturbance Analysis module has been productized and applied successfully at Eastman Kingsport, TN.

In their drive towards efficiency, modern industrial process plants are making increased use of recycle streams and heat integration. This integration of mass and energy complicates process control because variations can propagate through the plant in complex ways. Often, a single source of variation manifests itself as a widely distributed disturbance. A propagated disturbance can affect key process variables such as feed, product and recycle flows, column temperature and product composition. Such a disturbance can upset just a single unit, for example a distillation column, it can be plant-wide, affecting a complete production process or even site-wide if utilities such as the steam system are involved. When there are many disrupted or oscillating measurements, finding the root cause of the disturbance is akin to looking for a needle in a haystack. The motivation behind the product development presented here is the automatic detection of plant-wide disturbances and determination of likely root causes. This allows disturbances to be removed or dealt with by maintenance, new control schemes or simply controller re-tuning.

In recent years, universities have developed several innovative algorithms based on advanced signal processing, spectral and nonlinear time series analysis for use in industrial process diagnosis. To better apply such knowledge to the problem described

here, ABB initiated a project in cooperation with the Imperial College / UCL Centre for Process Systems Engineering (CPSE).

After preliminary field-tests, a large-scale pilot application of the methodology, using a first prototype implementation, was evaluated by ABB. The plant-wide disturbance technology was applied to measurement data from a Norwegian oil platform. The analysis of disturbances was based on data from more than 2000 measurement tags and more than one month's worth of data at high resolution.

In recent years, universities have developed several innovative algorithms based on advanced signal processing, spectral and nonlinear time series analysis for use in industrial process diagnosis.

Extensive analysis and discussion revealed significant disturbances that had also been identified by parallel plant investigations by process and process control experts from ABB and the customer. These encouraging results indicated that the intelligent analysis of process data can, to a great extent, help and support the work of

problem identification, localization and diagnosis.

The final step in the product development process was the integration into ABB's product portfolio. Due to the nature of the methodology in supporting process performance analysis, it was chosen to productize the Plant-wide Disturbance Analysis (PDA) functionality as a new module in ABB's control loop optimization software Optimize^{IT} Loop Performance Manager (LPM). The release containing the PDA module is now available from ABB.

Following a brief overview of the methodology, this article will present two successful and surprisingly accurate findings from an end-customer evaluation of the tool. Eastman Chemical Company, Kingsport, TN (title picture), has been testing the integrated tool with encouraging results.

Optimize^{IT} – Loop Performance Manager

Loop Performance Manager (LPM) is a control loop maintenance tool for control engineers, instrument technicians and maintenance personnel. It has been designed to provide a bridge between the technologies developed in academia, and the existing, relevant needs in the industrial world [4]. Its mission is to ensure that control loops, and – consequently – the whole production process, operates at peak performance.

1 LPM screen shot. A single environment for disturbance analysis, root cause detection, control loop monitoring and tuning

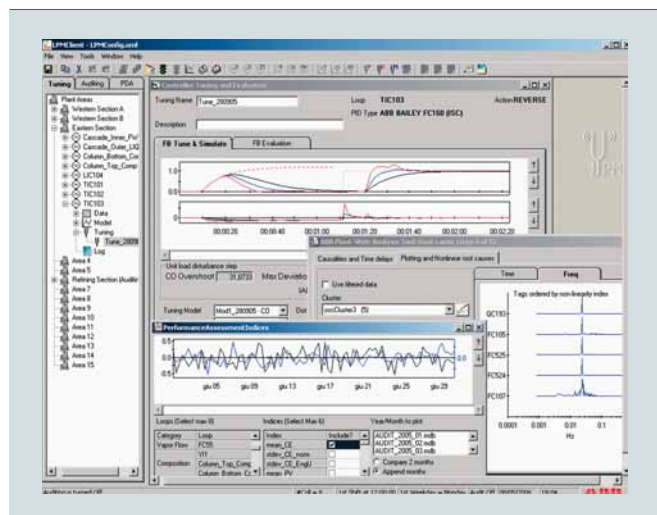

2 Typical work flow of PDA analysis within the Loop Performance Manager tool a) to e) are the five steps of this workflow

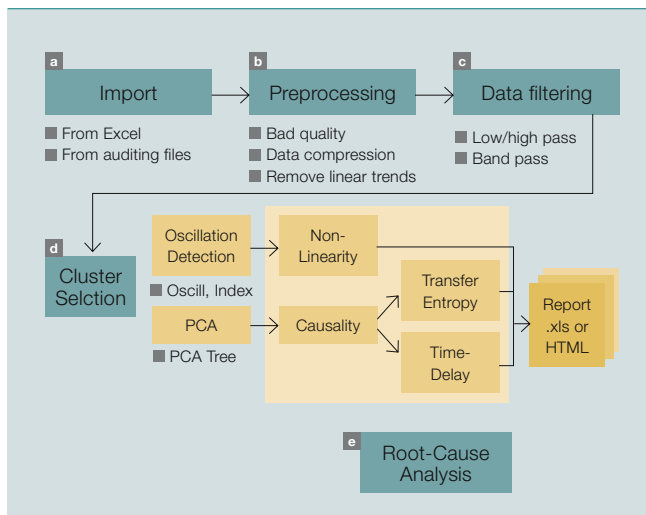

Operational profitability

The package has been structured in a modular way, currently consisting of three software applications:

- A control loop-tuning component used to improve control loop performance
- A control loop-auditing component used to monitor loop performance
- A Plant-wide Disturbance Analysis (PDA) component. This software simultaneously analyzes multiple loops detecting common behavior and identifying likely root causes.

1 shows a typical screen shot of the LPM tool.

Plant-wide disturbance analysis

A good survey of current research can be found in [6]. 2 shows the overall procedure of PDA within the LPM tool [7].

Data import

Data can be read offline from either Excel files or from data collected in the tool while performing control loop monitoring 2a.

Data pre-processing and filtering

Standard and simple functionality for data-pre-processing is very useful when different aspects of data, eg different frequency ranges are to be investigated. Also, garbage data, such as bad data, outliers or linear trends are filtered out automatically. The simple

representation of superimposed data in the form of a high-density plot, is already a very useful process for engineers. Such presentation modes are not usually available in historians or on operator screens 2b 2c.

Problem cluster selection

The first main step in the analysis is the detection of clusters of time trends that display similar periodically oscillating patterns. The oscillation detection is achieved with signal processing methods. In this context the signals are the time trends of the measurements. Oscillation detection has traditionally looked for zero crossings of the mean-centered signal. One weakness of this approach is that noise causes additional zero crossings, diminishing the value of the result. The key breakthrough applied here involves detecting oscillations using zero crossings of the signal's autocovariance function [1]. This provides a significant improvement over previous methods that used time trends directly 2d.

There is no restriction on the number of tags that can be handled. Past investigations used several hundred tags. These could be readily analyzed thanks to the efficient implementation of the underlying algorithms.

High-density plots as shown in 3 show time trends. An alternative way

of viewing such information is by spectral analysis. This method highlights periodic features rather than time trends. Frequency spectra have several advantages when it comes to the detection of distributed disturbances. However, it is the combined use of time and frequency approaches that is a strength of the described tool. The method the tool uses to select clusters is based on spectral principal component analysis [2].

A powerful way of presenting the spectral clusters is by means of a hierarchical tree, as described in [9]. Spectral clustering also works very reliably for time trends with non-periodic features, as long as their spectra are similar. Other, very intuitive ways of representing clusters are also included in the tool.

Finding the likely root cause for disturbance clusters

It is well known, eg [8], that a very common cause of disturbance in chemical processes is a faulty control valve with non-linear characteristics such as dead band or excessive static friction (known as stiction). The limit cycles arising from sticking control valves in a feedback control loop can propagate widely. For this reason, the tool was initially focused on the diagnosis of non-linear root causes. The methods developed for the diagnosis of sticking control valves can also be applied in locating faults originating in process nonlinearities such as periodic foaming in a distillation column or slugging flows in pipelines 2e.

Nonlinear trends

A *nonlinear time trend* [3] is a signal that cannot be described as the output of a linear system driven by white noise. It is characterized by phase coherence and, if it is oscillatory, by the presence of harmonics. An example of a very non-linear signal is one with a square wave pattern. A process plant typically acts as a low pass filter, which means that a measurement close to a non-linear source has more non-linearity than a measurement far away from the source. The nonlinear square pattern is smoothed as it propagates through the plant. This behavior is utilized to identify candidate areas for root causes.



One way to detect non-linearity is by visual inspection of the time trends and the spectra. However, this is a manual procedure that is unreliable, intricate and prone to error. The novel concept in the current approach is a nonlinearity assessment that is strongest at the source of the nonlinearity. In this way, the root cause oscillation can be distinguished from propagated secondary oscillations. The assessment index is large for periodic but non-sinusoidal oscillating time trends (that are typical of the output of a control loop with a limit cycle caused by nonlinearity).

The basis for the non-linearity assessment is a comparison of the predictability of each time trend and a set of constructed time trends that have the same power spectrum but random phases. A non-linear time trend will have a high predictability compared to the constructed time trends, whereas this difference will be small for a linear time trend [3].

The nonlinear square pattern is smoothed as it propagates through the plant. This behavior is utilized to identify candidate areas for root causes.

The power of the described methodology is underlined by the examples discussed below. A clear direction of operation and/or maintenance intervention can easily enable significant reductions in the time lost pursuing the wrong root causes. Furthermore, when applied to large-scale problems, the methodology enables the identification of problems that might never be identified manually since the root-cause may be located very far from its effect.

A data-driven, computer-aided methodology as shown here is a valuable support tool. It will not be able to replace human know-how but it can

- 3 Oscillatory data from a cluster with 68 minute oscillations. Data is sorted by nonlinearity, correctly indicating LC2 as the root cause

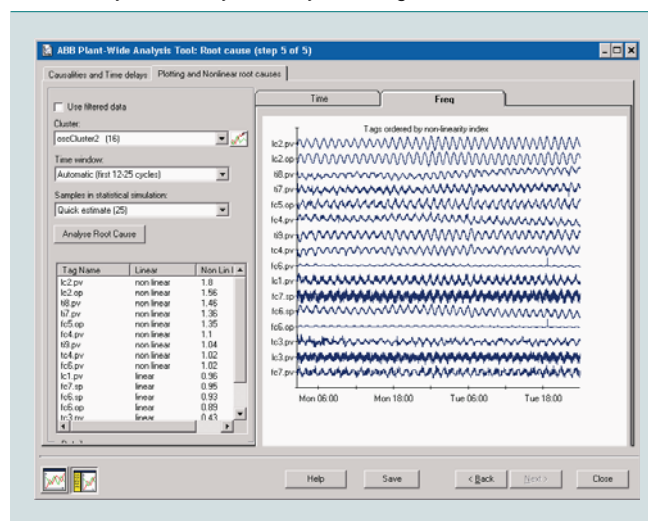

Key features of plant-wide disturbance analysis

- Automatic detection of the presence of one or more periodic oscillations
- Detection of non-periodic disturbances and plant upsets
- Determination of the locations of the various oscillations / disturbances in the plant and their most likely root causes

Optimize^{IT} Loop Performance Manager

Combining bottom-up monitoring (control loop auditing) with top-down disturbance analysis (PDA) with world-class controller tuning functionality offers the most comprehensive tool for process control staff on the market.

Industrial examples

PDA (Plant-wide Disturbance Analysis) analysis directed the process experts directly to the root-cause of plant-wide problems. These root causes were neither evident from looking at data nor from using process knowledge.

greatly reduce the effort in finding and mapping out the extent of plant-wide problems and locating their causes.

Two additional approaches to root-cause analysis are the use of transfer entropy and time-delay estimation methods [5].

Transfer entropy

This statistical method evaluates the predictability of a variable from another variable based on probability density functions (PDF). The causality measure used to quantify the extent of the influence of a variable X on

another variable Y is derived from transfer entropy $T(X|Y)$. The latter is itself derived from entropy which is a measure of uncertainty of a random variable summing a weighed logarithm of the PDF. Transfer entropy is calculated from the joint PDF of two variables. This provides a measure for the dependencies between those variables. The causality measure $t(X, Y)$ is derived by comparing the influence of X on Y with the influence of Y on X :

$$t(X, Y) = T(X|Y) - T(Y|X)$$

Thus, large values of $t(X, Y)$ indicate a strong causality from X to Y .

Time delay analysis

The second method implemented in the PDA module for causality analysis is based on the Cross-Correlation Function (CCF). This function determines causal relationships between measurements from the presence of time delay between them. The underlying principle of the method is that when the disturbance propagates through the plant, the disturbance can often be observed at a number of process variables with a time lag. Knowledge of the exact time lag provides clues towards the root cause because it can be argued that the variable closer to the root cause will show the disturbance earlier than a variable further away. The CCF measures the similarity between signals at different time instances and can therefore be used to evaluate time lags between signals.

Operational profitability

The CCF of two signals has a maximum value at a time value that is equal to the dead time.

The difference between these two methods for causality analysis is that the causality matrix based on transfer entropy is more sensitive. It can find a causal relationship even in situations with no measurable time delay, because it detects other effects such as smoothing of the time trend that occur as a disturbance propagates from its source.

A first industrial example

In the following, the process section of 4 is considered. This shows a section in a chemical plant consisting of

two distillation columns. As can be seen, most measurements cycle with a period of 68 minutes (see also 3). Process experts suggested several theories explaining this sustained oscillation. Hence several root causes were suggested.

Applying PDA root cause analysis for the cluster related to 68 minutes cycle time suggested that a nonlinear problem around level control loop LC2 was causing the oscillations in all other tags in that specific cluster. This hypothesis was, in fact, experimentally verified: The control in LC2 was retuned 4–5 times as aggressively as its normal tuning. As a consequence, LC2 cycled at a much higher frequency

and the downstream cycles in all the other variables no longer occurred. This gave the experts confidence that the root cause was within the LC2 loop and most likely a problem in the final control element. This hypothesis was also confirmed using LPM auditing analysis on the LC2 control loop data.

Plant-wide disturbance analysis has moved from being a subject of advanced academic research into a successful industrial application in the form of a released product.

4 Process schematic for Example 1

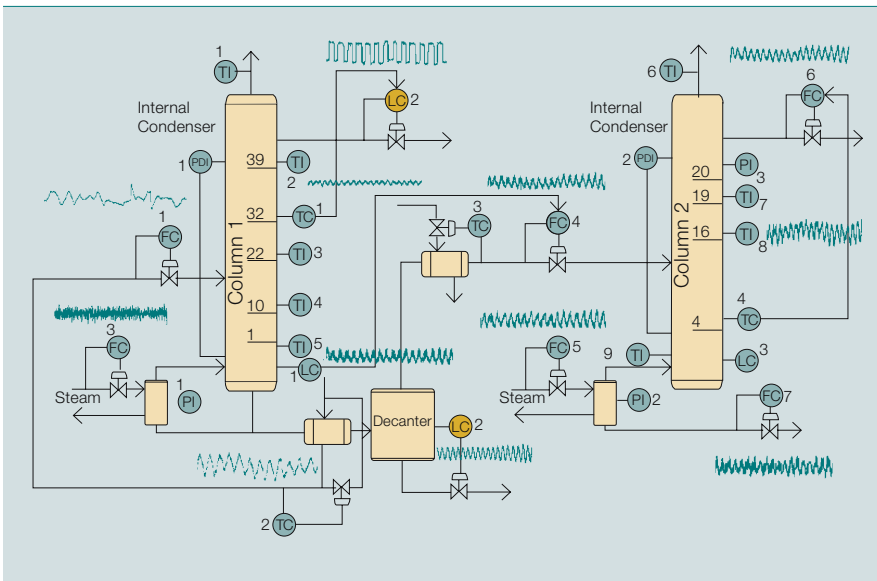

A likely explanation for the plant-wide upset is that the oscillation propagates through the plant section as the decanter is full of liquid. As a result, there is more or less flow through the LC2 valve and this affects the LC1 level measurement. LC1 in turn adjusts the feed FC4 (via the master-slave feedback) to column 2. The resulting cycles in FC4 affect several column 2 variables, including the distillate FC6.

There was also a secondary cycle in the data set. This oscillation was somewhat faster and the cluster involved another five measurements. Root cause analysis gave early indication of stiction behavior in FC2 – this is a correct result.

5 Oscillatory data distributed over a vaporizer system. The identified root cause is marked red.

a – d are vapor columns

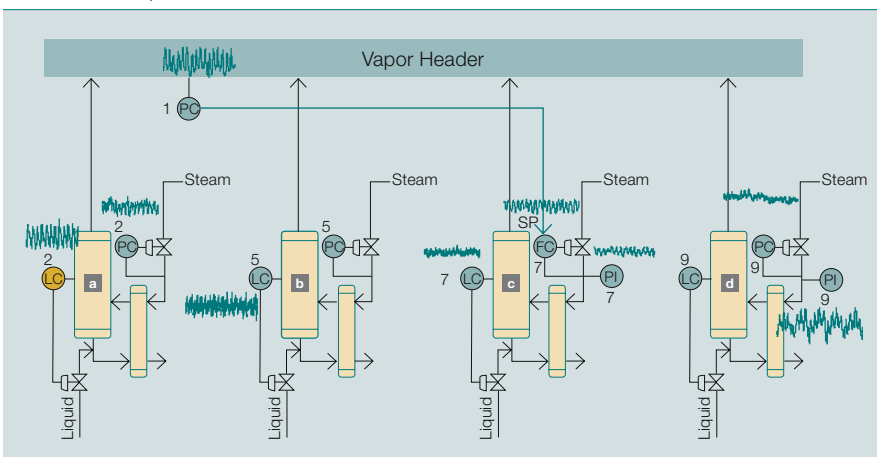

On the basis of these results, maintenance staff can improve the complete plant section performance by attending to the two indicated valve-related problems in LC2 and FC2.

Second industrial example

This example describes the disturbances found in a vaporizer system 5.

It can be seen that the pressure in the vapor header is oscillating at a period of 220 seconds. This frequency can clearly be found in all four vaporizers (5a, 5b, 5c, and 5d) that are used for steam and pressure generation. Vaporizer 5c is used for pressure control in the header. A natural first guess by

6 Level control loop LC2 data in Vaporizer A. **a** setpoint and process variable (0-100 percent), **b** manipulated variable (valve opening) (0-100 percent). The data shows a sticking behavior.

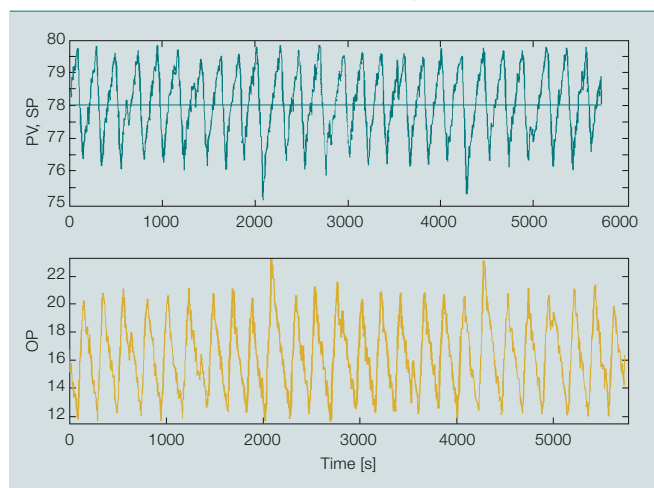

plant staff for a root cause was to investigate vaporizer **5c**.

When applied to large-scale problems, the methodology enables the identification of problems that might never be identified manually.

However, when applying PDA to this problem, a cluster including all related tags is easily identified. Using nonlinearity analysis, the level control loop (LC2) in vaporizer **5a** was identified **6**.

Experiments performed by process control experts actually verified that this was the – non-intuitive – root cause. In order to exemplify how LPM can be used for further confirmation, LPM Auditing was applied to this

loop. It generated the following diagnosis which was found true in the plant **Factbox**.

Conclusions

Plant-wide disturbance analysis has moved from being a subject of advanced academic research into a successful industrial application in the form of a released product. The industrial use cases show that innovative, modern technology offers great help to process experts in their root-cause analysis of important plant problems. These root causes are not always evident to plant personnel and advanced tool support can greatly reduce time spent on localizing these causes.

The unique combination of top-down and bottom-up approaches which combine the most important tools for process control engineers makes the ABB tool very powerful. Furthermore,

encouraging results have been achieved by applying the PDA methodology to new fields of application, eg, advanced alarm management and supervision and diagnosis of electrical networks.

Alexander Horch

ABB Corporate Research
Ladenburg, Germany
alexander.horch@de.abb.com

John Cox

Eastman Chemicals
Kingsport, USA

Nunzio Bonavita

ABB PS&S S.P.A.
Genova, Italy
nunzio.bonavita@it.abb.com

Factbox LPM Auditing output

```
- LC2: Overall loop assessment:
-----
The control loop performance is not acceptable.
- LC2: Detailed information:
-----
The control loop is oscillating.
- The control loop is oscillating.
- The control valve exhibits stiction that results in
loop oscillations. Put controller in manual to
verify.
The oscillation accounts for a significant part of
the overall variation. Removing the oscillation will
have lead to great improvement.
The oscillation amplitude is quite regular. This is
untypical for a pure (linear) tuning problem.
- The final control element introduces variability to
the output.
The control valve suffers from increased static
friction (stiction). A malfunctioning valve increases
loop variability. Put loop in manual or maintain
valve.
```

References

- [1] Thornhill, N. F., Huang, B., and Zhang, H., 2003, Detection of multiple oscillations in control loops, *Journal of Process Control*, 13, 91–100.
- [2] Thornhill, N. F., Shah, S. L., Huang, B., and Vishnubhotla, A., 2002, Spectral principal component analysis of dynamic process data, *Control Engineering Practice*, 10, 833–846
- [3] Kantz, H., and Schreiber, T., 1997, *Nonlinear time series analysis*. Cambridge University Press, Cambridge, UK.
- [4] Bonavita, N., Bovero, J.C., and Martini, R., 2004, Control loops: performance and diagnostics, in: 48th ANIPLA Conference, Milano, Italy, September 2004
- [5] Bauer, M., (2005) "Data-driven Methods for Process Analysis", PhD Thesis, University of London
- [6] Thornhill, N. F., and Horch, A., (2006) "Advances and new directions in plant-wide controller performance assessment", *Proc. Of ADCHEM 2006*, Gramado, Brazil, April, 2–5, 2006
- [7] Bonavita, N., Caserza-Bovero, J., De Lorenzo, L., Martini, R., 2006, "Control Performance Monitoring: a Data-driven Approach", *Proc. of Monitoraggio delle Prestazioni dei Processi e dei Sistemi di Controllo*, Milan 19 September 2006
- [8] Horch, A. (2006), "Benchmarking control loops with oscillations and stiction". In: *Process Control Performance Assessment*. (Ordys, A., Uduehi, D and Johnson, M.A, Eds), Springer, Guildford, UK.
- [9] Thornhill, N. F., Melbø, H., and Wiik, J., 2006, Multi-dimensional visualization and clustering of historical process data, *Industrial Engineering and Chemistry Research*, 45, 5971–5985.