

MEDIUM VOLTAGE PRODUCT

KOKM CABLE CURRENT INSTRUMENT TRANSFORMERS

Instructions for Installation, Use and
Maintenance

ENGINEERED
TO OUTFIT



TABLE OF CONTENTS

3	1. Service Conditions
3	2. Technical Details
4	3. Instructions for Installation
4	General information
4	Safety instructions
4	Mounting
5	Connection of the transformer primary side
5	Connection of the transformer secondary side
5	4. Instructions for Use
5	Routine test report
7	5. Information for Users within the meaning of Section 23 of the Measurement and Calibration Ordinance (MessEV)
7	6. Instructions for Maintenance
7	7. Transport & Storage
7	8. Disposal
7	9. Handling
8	10. Normative References
9	Appendix 1. Examples of Electrical Wiring / Secondary Marking

Instructions for Installation, Use and Maintenance for Cable Current Instrument Transformers

These instructions apply for cable current instrument transformers intended for indoor operation, where primary insulation is provided by primary conductor and its insulation. KOKM transformers are designed for $U_{sys} > 1$ kV.

The instructions refer to the following types: KOKM 06, KOKM 072, KOKM 1, KOKM PG

1. Service Conditions

The transformers need to be installed in dry and indoor conditions where the ambient air is not significantly polluted by dust, smoke, corrosive gases, vapours or salts.

The transformers are designed for standard ambient temperatures between -5 °C and $+40$ °C and altitudes below 1 000 m above sea level. The transformers can operate at a higher or lower temperature range (e.g., -25 to $+40$ °C) and higher installation altitude, if agreed with the manufacturer. A requirement for a different temperature range and higher installation altitude must be clearly stated in the offer request or purchase order.

Transformers should be installed according to service conditions for instrument transformers. The ambient air should not be significantly polluted by dust, smoke, corrosive gases, vapours or salts. The average value of the relative humidity, measured for a period of 24 h should not exceed 95%, the average value of the water vapour pressure for a period of 24 h should not exceed 2.2 kPa.

Vibrations caused by external influences on instrument transformers or earthquakes are negligible.

ABB	s. n.	1VLT5120075923
KOKM 1FF6		
1000//1	50/60Hz	
S1-S2	1000/1A cl.0.5	5VA ext.120%
0.72/3kV	l _{cth} : 1200 A	-5/40°C
IEC 61869-2	l _{th} : 60(1s)kA	E
TCM 212/11-4825	l _{dyn} : 150kA	2020
	Made by ABB	

2. Technical Details

Technical details and specifications of each of the transformers are shown on a rating plate fixed to the transformer body. It is not allowed to operate the transformer at values exceeding the nameplate data. Dimensional drawings of KOKM transformers are defined in the Catalogue. Dimensions of the KOKM transformers are defined by the type marking, see the example:

Where:

1VLT5120075923	serial number
KOKM 1FF6	type code of transformer
50/60 Hz	rated frequency
S1-S2	terminal marking
1000/1A	rated transformer ratio
1 or 5 A	rated secondary current
Ext.120 %	ratio extension
5 VA	rated output (burden)
0.5	accuracy class
0.72/3 kV	highest voltage for equipment / power-frequency withstand voltage
I _{cth} : 1200 A	rated continuous thermal current
I _{th} : 60 (1 s) kA	rated short-time thermal current and duration
IEC 61869-2	corresponding standard (standards)
I _{dyn} : 150 kA	rated dynamic current
TCM 212/11-4825	metrological standard
2020	year of manufacture
E	insulating temperature class
-5/40 °C	ambient temperature

01. Example of cable current instrument transformer rating plate

Current transformer for indoor use

The example of type designation for **KOKM 1 DC 10**:

KOKM 1 D C 10



Type designation

Rated voltage in kV

06 = 0.72/3/-

072 = 0.72/3/-

1 = 1.2/6/-

Hole diameter in cm

A = 3.3 H = 10.0 V = 31.5

B = 4.2 K = 12.0 W = 35.0

C = 5.0 L = 13 or 21.2x7 X = 40.0

D = 6.0 N = 15.5 Y = 45.0

E = 7.0/7.2/7.5 R = 18.0 Z = 50.0

F = 8.5 S = 20.0

G = 9.0 U = 25.0

Outer diameter in cm (see drawing)

B = 12.8 J = 23.5 P = 34.0

C = 14.8 K = 25.0 S = 40.0

F = 18.6 L = 27.0 T = 45.0

H = 20.0 M = 28.0 W = 59.0

M, N, F = oval design

R = doppelring-design

B, C, D, F, H, J, K,
M, P, S, T, W = ring design

Transformers width in cm

possible values - 6,8,9,10,12,14,15,16,18,20,22,24,25,26,28,30

3. Instructions for Installation

General informations

Instrument transformer is an electrical equipment and the electrical installation of the instrument transformer can be done by skilled personnel only. The level of experience, age and eligibility criteria for persons working with, on or near electric installations is governed by national legislation. If no such eligibility legislation is available the corresponding requirements can be found in EN 50110-1 standard.

Safety instructions

1. Always consider the transformer as a part of electric circuit which it is connected to. Don't touch incoming connectors and terminals, or any other parts of the transformer, except you know for sure these are earthed.
2. Ground always the metallic base of the instrument transformer, if exist.
3. Connect always one terminal of each secondary winding of the transformer to the earth. When the secondary of transformer is interconnected, there should be only one grounded point to prevent accidental paralleling with system grounding wire.

4. Always short-circuit the secondary of the current transformer, which is not currently in use, to prevent secondary voltages, which may be hazardous to personnel or damaging to the transformer's secondary. The secondary like this must be additionally grounded.

Mounting

The KOKM type transformers are designed for low voltages of 0.72/3 kV KOKM 06, KOKM 072 or 1.2/6 kV (KOKM 1) and KOKM PG, without built-in primary conductor. Their use at higher voltage levels needs always the transformers to have combined with primary conductor provided with its own insulation. The primary conductor is not a part of transformer delivery. Therefore, the KOKM transformers are mounted and placed at the option of the customer, based on the application chosen and the insulated conductor used on the primary side. Types of the transformer fixation are visible on Fig. 2 – Fig. 5.

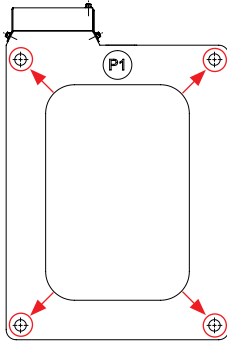

02 Window type 4 holes: Fixation is done by 4 straight-through holes with 15 mm diameter. Screws for fixation are not part of delivery. For exact dimension see the catalogue for specific type. Connection of transformer primary side.

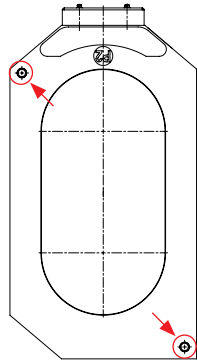

03 Window type 2 holes: Fixation is done by 2 straight-through holes with 12 mm diameter. Screws for fixation are not part of delivery. For exact dimension see the catalogue for specific type.

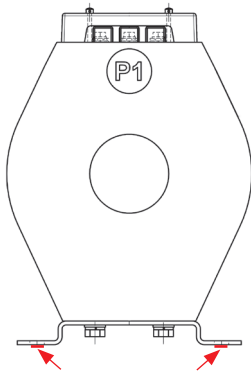

04 Ring core type, with base: Fixation is done by 2 or 4 holes in the base of transformer. Screws for fixation are not part of delivery. For exact dimension see the catalogue for specific type.

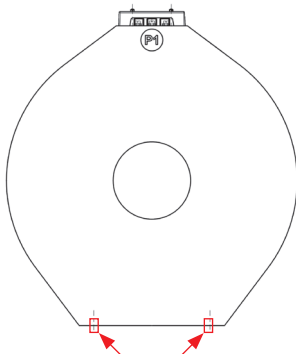

05 Ring core type, without base : Fixation is done by 4 nuts casted in the transformer. Screws for fixation are not part of delivery. For exact dimension see the catalogue for specific type.

Connection of transformer primary side

The KOKM transformers don't have their own primary conductor. The primary conductor is designed as a bushing with its own insulation, or insulated cable. Primary conductor shall be centered in the application. The centering is shown in picture 6.

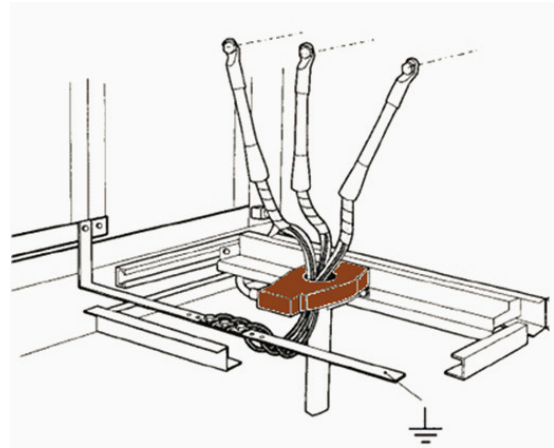

06 Example of use

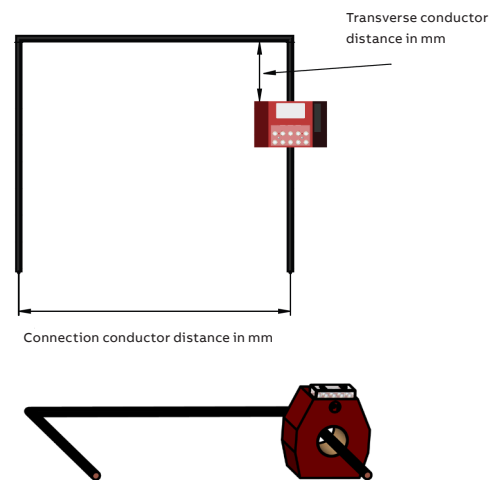

07 Example of centering

Type	Minimum distance of the connection conductor in mm	Minimum spacing of the transverse conductor in mm
KOKM 06 LM xx	150	50 (0*)
KOKM 06 NN xx	230 (160**)	230 (0**)
KOKM 072 EF xx	195	0
KOKM 072 ER xx	220	100
KOKM 1 EB xx	130	0
KOKM 1 ED xx	130	0
KOKM 1 LH xx	130	0
KOKM 1 NJ xx	130	0

*max. 2700 A

**max. 1950 A

Connection of the transformer secondary side

The KOKM transformers have two types of secondary connection according to design.

1) Cables

PTB certified instrument transformers with secondary cable output should be installed according to PTB Bekanntmachung Nr. 3729.



Length and type of the cable is variable according to the types (see catalogue)

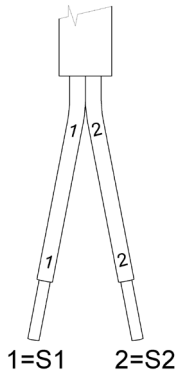

All cable outlets have marking according to the connection

2) Secondary terminal



Example of secondary terminal connection realized by screws with cover

Example of secondary terminal connection realized by screws without cover

Tighten the secondary terminal connection by M6 screw with the highest torque 4 Nm and the lowest torque 3 Nm. **Maximum permissible tightening torque for M3 screws securing plastic terminal cover is 0.5 Nm.**

Maximal diameter of cable or conductor connected to one secondary terminal: 2 x 2.5 mm. There is allowed to use only the screws delivered with transformer into secondary terminals. In case of any need to use different screw be sure that the thread hole and diameter is correct for non original screw. Otherwise there is high risk of damage of the terminal and the manufacturer is not liable for the converter function.

KOKM 072 xA 10 and KOKM 072 xB 10 secondary connection is done by terminal block equipped with M3 screws with the highest torque 0.8 Nm and the lowest torque 0.6 Nm.

Maximum cross sections of secondary cables are 4 mm² (strand) or 6 mm² (solid conductor).



Example of secondary terminal connection realized by terminal block with cover

Example of secondary terminal connection realized by terminal block without cover

4. Instructions for Use

Current instrument transformers are used:

- to convert large currents in the primary circuit to an appropriate level for secondary circuit equipment (relays and meters);
- to insulate primary and secondary circuit from each other to protect the secondary equipment from the harmful effects of large current appearing during the operation (short circuits).

The use of current transformer for other purpose than described above is forbidden if not agreed with the producer. If it is necessary to repair the transformer, it is necessary to consult this repair with the manufacturer.

Routine test report

The routine test report of a current instrument transformer includes:

- verification of terminal markings;
- inter-turn overvoltage test;
- determination of errors.

On customer request the following information can be provided free of charge:

- theoretical current/voltage error and phase displacement values;
- theoretical excitation (magnetization) curves.

Onsite test should be performed according to installation manual of the application.

Additional reports for supplementary charge, made available on request:

- test report on accuracy;
- excitation (magnetization) curves;
- additional nameplates (if more than 2 are required);
- verification tests for measuring cores (classes 0.2; 0.2 S; 0.5; 0.5 S).

5. Information for Users within the Meaning of Section 23 of the Measurement and Calibration Ordinance (MessEV)

The measurement winding of the appliance transformer can be used for billing purposes if the metrology regulations applicable in the country of installation of the appliance transformer are met. The "approval certificate for the measuring device type" and the certification ("calibration") of the transformer (e.g. in the Czech Republic) or the assessment of conformity with the metrology regulations that was carried out with module D or F (e.g. in Germany) can be requested. . In this case, all measuring windings (classes 0.5, 0.5 S, 0.2 or 0.2 S) of the device transformer are certified ("calibrated") or subjected to the tests as part of the conformity assessment with module D or F.

Transformers used for tariff metering have sealed secondary terminals to prevent unauthorized interference with the wiring of the secondary circuits.



08 Sealing of secondary terminals for tariff metering

6. Instructions for Maintenance

Excessive dust sediments or any other type of contamination must be removed from the transformer by a soft brush, in a way not to damage the insulation or cables taken out from the transformer.

7. Transport & Storage

Permitted temperature for transport and storage ranges from -40 °C to +70 °C. During transport and storage the transformers have to be protected from direct impact of solar radiation. The transformers are delivered in wooden crates or fixed on transport pallets.

8. Disposal

Materials used in instrument transformers are considered as materials without environmental impact and materials are not toxic. Instrument transformers have to be disposed of in accordance with national legislation relevant to domestic waste disposal.

9. Handling

Most of the KOKM transformers weight less than 25 kg and, consequently, they can be handled manually. In case of higher weight it is necessary to use carry belts threaded through the transformer internal opening.

ATTENTION: The process of transformer handling has to comply the occupational health and safety rules. It is forbidden to stay or move below a suspended load. Always make sure the load is safely tied and secured, what makes its loosening or turnover impossible. All transformers has to be carried carefully to prevent any damage to the transformer.

10. Normative References

- IEC 61869-1 Instrument transformers: General requirements
- IEC 61869-2 Instrument transformers: Additional requirements for current transformers
- IEC 60529 Degrees of protection provided by enclosures
- ISO 12100 Machine safety – basic concepts, general principles of design
- EN 50110-1 Operation of electrical installations

Current instrument transformers are designed, tested and manufactured in accordance with international or national standards, the customer requirements, based on an agreement between the customer and the manufacturer. The specific standard is always mentioned on the transformer nameplate.

As an example the following standards can be mentioned:

- IEC 60044-1; IEC 60044-6; IEC 61869-1;
- IEC 61869-2;
- AS 60044-1; AS 1243-1982;
- ČSN 351301; ČSN 351361;
- ČSN EN 60044-1; ČSN EN 60044-6;
- IEEE Std C57.13.6-2005;
- ANSI C57.13-1978;
- CSA Std CAN3-C13-M83;
- GOST 1516.3-96; GOST 7746-2001;
- BS 3939:1973; BS EN 60044-1.

When agreed transformers made in accordance with other standards can also be supplied, or in accordance with other release version of the above standards.

Appendix 1.

Examples of electrical wiring /secondary marking

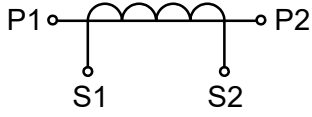

one secondary winding example: 100/1 [A/A]

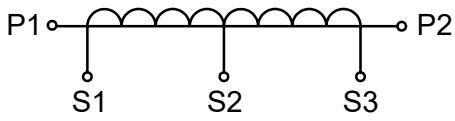

multi-tap secondary winding example: 50-100/1 [A/A]

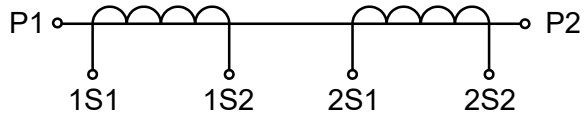

two secondary winding example: 800/5/5 [A/A/A]



CONTACT US

ABB s.r.o.

ELDS Brno

Videnska 117, 619 00 Brno,
Czech Republic

Tel.: +420 547 152 036
+420 547 152 854

E-mail: kontakt@cz.abb.com

www.abb.com

NOTE

We reserve the right to make technical changes or modify the contents of this document without prior notice. With regard to purchase orders, the agreed particulars shall prevail. ABB does not accept any responsibility whatsoever for potential errors or possible lack of information in this document.

We reserve all rights in this document and in the subject matter and illustrations contained therein. Any reproduction, disclosure to third parties or utilization of its contents - in whole or in parts - is forbidden without prior written consent of ABB.

Copyright© 2026 ABB
All rights reserved