

# Digital Indicator DS 96/20 E



The indicator is suitable for measuring direct voltage or direct current. The power supply is electrically isolated from the measuring circuit. By removing the front panel, the display range can be matched at two potentiometers.

**Technical data**

**Readout**

Display  
LED, red or green, 13 mm high numerals

Maximum reading  
± 19999 digit

Overload display  
flashing zeros

Decimal point  
placeable/can be switched off

Specialities  
Segment test  
Display storage  
Retrace blanking display

**Display activation** (optional)

Display of the units position  
fixed 0 or as 2-step

Measuring cycle  
2 s or 10 s

Brightness  
can be reduced using potentiometer behind front panel

**Input**

Measuring method  
Dual-slope, sequence 2.5/s

Deviation (23 °C)  
0.05 % ± 1 digit

Temperature coefficient  
0.05 % of final value/10 K

Effect of power supply  
0.1 % of final value over the tolerance range

Measuring range limits  
Direct current ± 0.2...200 mA  
Direct voltage ± 0.2...50 V

Internal resistance  
≥ 1 MΩ for ≥ 2 V; 100 Ω for 20 mA

Overload  
100 V for ≥ 2 V; 5 V for < 2 V; 50 mA for 20 mA

Suppression of parasitic voltage  
SMR > 40 dB (50 Hz)  
CMR > 100 dB (0/50 Hz)

Setting thresholds for display (min.)  
Start ± 1000 digit of required rated value  
End ± 10 % of required display range

**Transmitter supply** (optional)

Output  
25 V DC ± 1 V; Residual ripple < 150 mVss

Load  
max. 25 mA

**Power supply**

Direct or alternating voltage  
18... 82 V DC, 18... 68 V AC, 48...62 Hz, approx. 3 W  
80...280 V DC, 80...260 V AC, 48...62 Hz, approx. 3 W

Alternating voltage  
24 V AC ± 10 %, 48...62 Hz, approx. 6VA  
115 V AC ± 10 %, 48...62 Hz, approx. 6 VA  
230 V AC ± 10 %, 48...62 Hz, approx. 6 VA

**General and safety data**

Electromagnetic compatibility (EMV)  
Parasitic radiation EN 55011 Klasse A  
Interference immunity EN 50082-1

Low-voltage directive to EN 61010-1 met

**Environmental capabilities**

Operating temperature range  
0...50 °C

Transport and storage temperature  
-40...+75 °C

Relative humidity  
75 % annual average, no condensation

**Case and mounting**

Dimensions  
see dimensional diagram

Material  
Sheet metal

Colour of front panel  
black

Connection  
Screwed brackets for max. 1.5 mm<sup>2</sup>

Type of protection  
Case IP 50  
Terminals IP 20

Weight  
approx. 0.7 kg

Terminal assignment  
see terminal diagram

**Dimensional drawing and connection diagram**

**Dimensional drawing** (dimensions in mm)

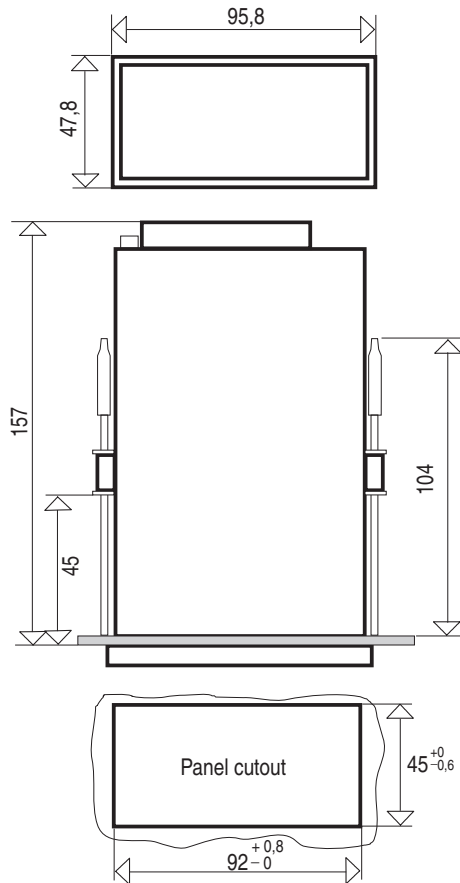

**Connection diagram**

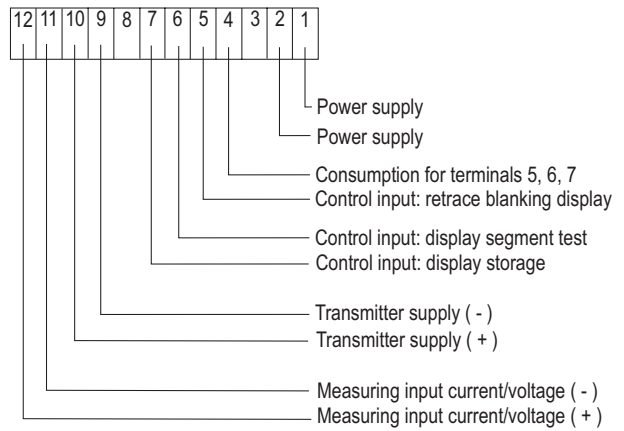

Ordering information									
					Catalog No.			Code	
<b>Digital indicator DS 96/02 E</b>					<b>V33166A-</b>				
<b>Measuring input</b>									
0...2 V					1				
0...20 V					2				
0...20 mA					5				
4...20 mA					6				
other					0				
<b>Decimal point position</b>									
0.0000					1				
00.000					2				
000.00					3				
0000.0					4				
without					0				
<b>Power supply</b>									
230 V AC					1				
115 V AC					2				
24 V AC					3				
18...82 V DC / 18...68 V AC					4				
80...280 V DC / 80...260 V AC					5				
<b>Display control</b>									
without					0				
2-step display (0-2-4-6-8)					1				
fixed 0 display of last position					2				
Specialities									
<b>other measuring range</b> (consider alarm data)					(clear text)			326	
<b>Display range other than measuring range</b> (state assignment of input to range)					(clear text)			361	
<b>Dimension according to table</b>					(clear text)			368	
<b>Dimension as required</b> (max. 5 characters)					(clear text)			369	
<b>Measuring rate 2 s</b>								531	
<b>Measuring rate 10 s</b>								532	
<b>green LED</b>								556	
<b>special lettering</b> (max. 18 characters)					(clear text)			566	
<b>Bezel grey RAL 7037</b>								568	
<b>Transmitter supply</b>								580	
<b>Operating Manual<sup>1)</sup></b> German/English								Z1Y	

<sup>1)</sup> 1 copy in German included in the basic supply; no specification required; extra Operating Manuals must be paid (please specify number)

Dimensional labelling													
	Code		Code		Code		Code		Code		Code		Code
none	400	kW	406	A	412	MN	418	m <sup>3</sup>	424	N	430	ppm	436
V	401	MW	407	mA	413	%	419	g	425	bar	431	K	437
mV	402	Ω	408	μA	414	‰	420	kg	426	m/min	432	l/h	438
kV	403	mΩ	409	°C	415	cm	421	t	427	U/min	433	t/h	439
mW	404	kΩ	410	°∠	416	mm	422	m <sup>3</sup> /h	428	δ	434	Hz	440
W	405	MΩ	411	kN	417	m	423	ph	429	mbar	435		







# Contact us

## **ABB Ltd.**

### **Process Automation**

Howard Road, St. Neots  
Cambridgeshire, PE19 8EU  
UK

Phone: +44 (0)1480 475321

Fax: +44 (0)1480 217948

## **ABB Inc.**

### **Process Automation**

125 E. County Line Road  
Warminster PA 18974  
USA

Phone: +1 215 674 6000

Fax: +1 215 674 7183

## **ABB Automation Products GmbH**

### **Process Automation**

Borsigstr. 2  
63755 Alzenau  
Germany

Phone: +49 551 905-534

Fax: +49 551 905-555

[www.abb.com](http://www.abb.com)

## Note

We reserve the right to make technical changes or modify the contents of this document without prior notice. With regard to purchase orders, the agreed particulars shall prevail. ABB does not accept any responsibility whatsoever for potential errors or possible lack of information in this document.

We reserve all rights in this document and in the subject matter and illustrations contained therein. Any reproduction, disclosure to third parties or utilization of its contents – in whole or in parts – is forbidden without prior written consent of ABB.

Copyright© 2011 ABB

All rights reserved

3KXJ300004R1001

10/33-2,19-EN 01.2011