



Features

- Two-phase low-set phase overcurrent unit with definite time or inverse time characteristic
- Two-phase high-set phase overcurrent unit with instantaneous or delayed operation
- Directional low-set neutral overcurrent unit with definite time characteristic
- Directional or non-directional high-set neutral overcurrent unit with instantaneous operation
- Four standardized inverse time curves according to IEC and BS and two additional special type curves
- Integrated circuit-breaker failure protection with adjustable operate time
- Numerical display of setting values, measured values, values recorded in fault situations, etc.
- High immunity to electrical interference and an IP54 degree of protection by enclosure
- Sophisticated self-supervision system with auto-diagnostic features
- Serial interface for extensive data exchange with the substation level data acquisition and control system over the fibre-optic SPA bus
- Powerful software support for parameterization of the relay, for reading measured and recorded values, events, etc., and for storing readings
- Member of the SPACOM product family, ABB's Distribution Automation system and ABB's Panorama concept
- CE marking according to the EC directive for EMC

Application

The numerical feeder protection relay SPAA 120 C is designed to be used for selective short-circuit and earth-fault protection of radial distribution networks. The feeder protection relay is an integrated device incorporating a two-phase phase overcurrent unit and a directional neutral overcurrent unit in one relay. Further, the feeder protection relay incorporates circuit-breaker failure protection.

When sensitive earth-fault protection is required, the feeder protection relay type SPAA 121 C is recommended. The feeder protection relays SPAA 120 C and SPAA 121 C have identical functions. The only difference between the two relays is the rated current of the earth-fault relay units, i.e. 1 A and 5 A for the relay SPAA 120 C and 0.2 A and 1 A for the relay SPAA 121 C.

Design

The relay continuously measures two phase currents, the residual current and the residual voltage of the protected feeder. When a fault occurs, the relay starts and, if the fault persists long enough to exceed the set or calculated operate time of the relay, it operates. The relays can also be used to start a cooperating external auto-reclose relay, if applicable.

The feeder protection relay consists of a combined overcurrent and earth-fault relay module SPCJ 4D44, an input/output module and an auxiliary supply module housed in a size 100/S relay case.

The combined overcurrent and earth-fault module SPCJ 4D44 comprises two units, i.e. a two-phase overcurrent unit and a directional earth-fault unit.

The overcurrent unit includes a low-set stage $I_{>}$, and a high-set stage $I_{>>}$. The low-set stage can be given definite time characteristic or inverse time characteristic while the high-set stage has a definite time characteristic or operates instantaneously. The set start value of the high-set stage can be automatically doubled, a feature which can be used to prevent unintended operation due to, for instance, switching inrush currents.

The directional earth-fault unit includes a low-set stage $I_{01}>$ and a high-set stage $I_{02}>$. Both stages have a definite time characteristic. The operate time of the low-set stage is adjustable within the range 0.1...300 s, that of the high-set stage can be set at 100 ms or 750 ms. The basic angle of the directional element can be set at 0°, -30°, -60° or -90°, which means that the relay can be used in both isolated neutral networks and resonant earthed networks.

The feeder protection relay is provided with circuit-breaker failure protection (CBFP) operating as back-up protection for the main protection

Data communication

The feeder protection relay is provided with a serial interface on the rear panel. By means of a bus connection module type SPA-ZC 21 or SPA-ZC 17 the feeder protection relay can be connected to the fibre-optic SPA bus. The bus connection module SPA-ZC 21 is powered from the host relay, whereas the bus connection module type SPA-ZC 17 is provided with a built-in power unit, which can be fed from an external secured power source. The relay communicates with higher-level data acquisition and control systems over the SPA bus.

Self-supervision

The relay incorporates a sophisticated self-supervision system with auto-diagnosis, which increases the availability of the relay and the reliability of the system. The self-supervision system continuously monitors the hardware and the software of the relay. The system also supervises the operation of the auxiliary supply module and the voltages generated by the module.

When a permanent internal relay fault is detected, the IRF indicator on the relay front panel is lit. At the same time the output relay of the self-supervision system operates and a fault message is transmitted to the higher-level system over the serial bus. Further, in most fault situations, a fault code is shown in the display of the protection relay module. The fault code indicates the type of the fault that has been detected.

Auxiliary supply voltage

The auxiliary supply of the relay is obtained from an internal plug-in type power supply module. Two auxiliary power module versions are available: type SPTU 240R1 for the supply voltage range 80...265 V ac/dc and type SPTU 48R1 for the supply voltage range 18...80 V dc. The power supply module forms the internal voltages required by the protection relay and the I/O module.

Technical data

Table 1: Energizing inputs, current inputs

Terminals		1-3, 7-9, 25-27	1-2, 7-8, 25-26
Rated current I_n		1 A	5 A
Thermal withstand capability	continuously	4 A	20 A
	for 10 s	25 A	100 A
	for 1 s	100 A	500 A
Dynamic current withstand capability	Half-wave value	250 A	1250 A
Input impedance		$\leq 100 \text{ m}\Omega$	$\leq 20 \text{ m}\Omega$

Table 2: Energizing inputs, voltage inputs

Terminals	28-29	28-30
Rated voltage U_n	100 V	110 V
Continuous voltage carrying capability	$2 \times U_n$	
Power drain of the energizing input at rated voltage	$\leq 0.5 \text{ VA}$	
Rated frequency f_n , according to order	50 Hz or 60 Hz	

Table 3: Output contact ratings

Type of contact		Tripping	Signalling
Terminals		65-66, 74-75	70-71-72, 68-69, 77-78, 80-81
Rated voltage		250 V ac/dc	
Thermal withstand capability	Carry continuously	5 A	5 A
	Make and carry for 0.5 s	30 A	10 A
	Make and carry for 3 s	15 A	8 A
Breaking capacity for dc, when the control circuit time constant $L/R \leq 40 \text{ ms}$, at the control voltage levels	220 V dc	1 A	0.15 A
	110 V dc	3 A	0.25 A
	48 V dc	5 A	1 A
Contact material		AgCdO ₂	

Table 4: External control input

Blocking remote reset or remote setting input	10-11
External control voltage level	18...265 V or 80...265 V ac
Typical control current of activated input circuit	2 mA

Table 5: Data communication

Transmission mode		Fibre-optic serial bus
Data code		ASCII
Transfer rates, selectable		4800 or 9600 Bd
Optional bus connection module, powered from an external power source	for plastic core cables	SPA-ZC17 BB
	for glass fibre cables	SPA-ZC17 MM
Optional bus connection module, powered from the host relay	for plastic core cables	SPA-ZC21 BB
	for glass fibre cables	SPA-ZC21 MM

Technical data (cont'd)

Table 6: Relay module SPCJ 4D44, overcurrent unit

Features		Low-set stage I>	High-set stage I>>
Start current	at definite time	$0.5...5.0 \times I_n$	$0.5...40.0 \times I_n$ or ∞ , infinite
	at inverse time	$0.5...2.5 \times I_n$	–
Start time, typically		60 ms	40 ms
Operate time at definite time characteristic		0.05...300 s	0.04...300 s
Time/current characteristic at IDMT operation characteristic		Extremely inverse Very inverse Normal inverse Long-time inverse RI type inverse RXIDG type inverse	–
Time multiplier k		0.05...1.00	–
Reset time, typically		50 ms	50 ms
Drop-off/pick-up ratio, typically		0.96	
Operate time accuracy at definite time operation characteristic		$\pm 2\%$ of set value or ± 25 ms	
Operate time accuracy class E at inverse time operation characteristic		5	–
Operation accuracy		$\pm 3\%$ of set value	

Table 7: Relay module SPCJ 4D44, earth-fault unit

Features		Low-set stage $I_{01}>$	High-set stage $I_{02}>>$
Basic angle ϕ_b		$0^\circ, -30^\circ, -60^\circ$ or -90°	
Operation sector $\Delta\phi$		$\pm 80^\circ, \pm 88^\circ$	
Residual voltage stage $U_{0>}$	Start voltage $U_{0>}$	$2.0...80.0\%$ of U_n	
Operation direction		Forward or reverse	
Operation mode		Directional	Directional or non-directional
Start current		$1.0...25\%$ of I_n	$2.0...150\%$ of I_n or ∞ , infinite
Start time, typically		100 ms	–
Operate time		0.1...300 ms	100 ms or 750 ms
Reset time, typically		80 ms	100 ms
Internal reset time of intermittent operation		–	500 ms
Drop-off/pick-up ratio, typically		0.96	
Operate time accuracy		$\pm 2\%$ of set value or ± 25 ms	
Operation accuracy		$\pm 3\%$ of set value + $0.0005 \times I_n$	$\pm 3\%$ of set value or ± 25 ms

Table 8: Auxiliary supply modules

Terminal numbers		X1/1-2
Power module SPTU 240R1	rated voltages U_n	110/120/230/240 V ac
	operative voltage range	80...265 V ac/dc
Power module SPTU 48R1	rated voltages U_n	24/48/60 V dc
	operative voltage range	18...80 V dc
Power consumption, quiescent/operation conditions		4 W/6 W

Table 9: Tests and standards

Test voltages	Insulation resistance voltage (IEC 255-5)	>100 M Ω , 500 V dc
	Impulse test voltage (IEC 255-5)	5 kV, 1.2/50 μ s, 0.5 J
	Insulation test voltage (IEC 255-5)	2 kV, 50 Hz, 1 min
Interference tests	High-frequency (1 MHz) disturbance test (IEC 255-22-1, class III), common mode	2.5 kV
	High-frequency (1 MHz) disturbance test (IEC 255-22-1, class III), differential mode	1.0 kV
	Fast transients (IEC 255-22-4, class III and IEC 801-4, level 4), power supply inputs	4 kV, 5/50 ns
	Fast transients (IEC 255-22-4, class III and IEC 801-4, level 4), other inputs	2 kV, 5/50 ns
	Electrostatic discharge (IEC 255-22-2 and IEC 801-2, class III), air discharge	8 kV
	Electrostatic discharge (IEC 255-22-2 and IEC 801-2, class III), contact discharge	6 kV
	Environmental conditions	Specified ambient service temperature range
	Transport and storage temperature range (IEC 68-2-8)	-40...+70°C
	Temperature influence on the operate values of the relay over the specified ambient service temperature range	<0.2%/°C
	Long term damp heat withstand (IEC 68-2-30)	≤95%, +40°C, 56 d
	Degree of protection by enclosure of flush-mounted relay case (according to IEC 529)	IP 54
	Weight of the relay including flush-mounting case	4.5 kg

Block diagram

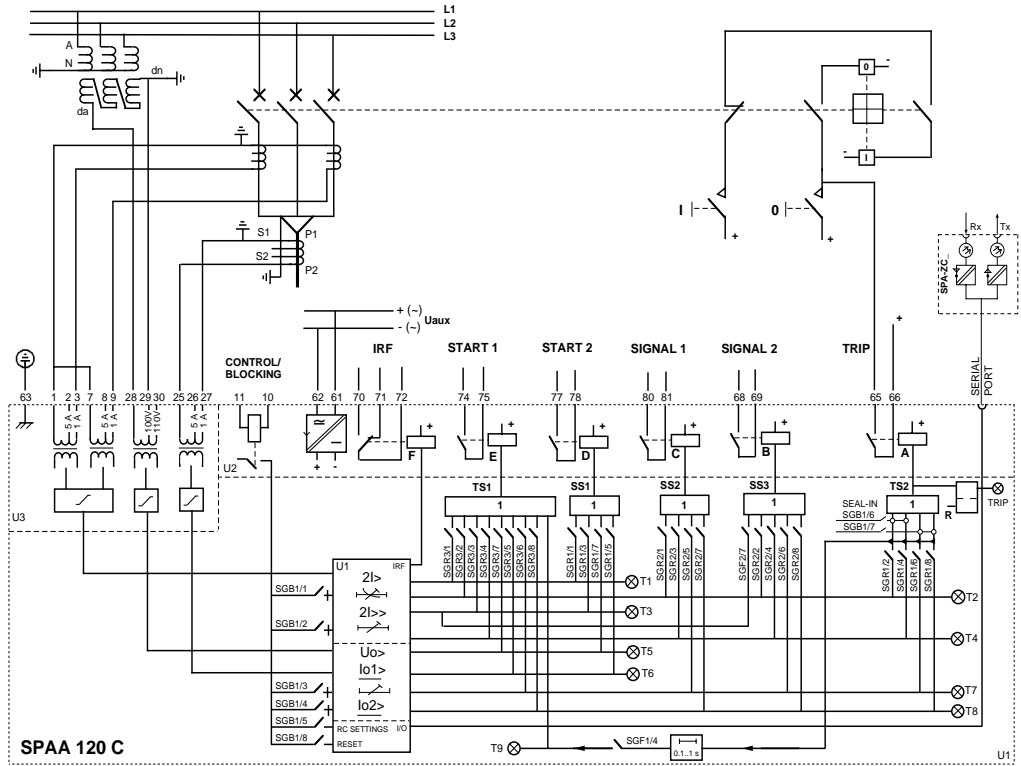

Fig. 1 Block diagram and sample connection diagram

Mounting and dimensions

Flush mounting

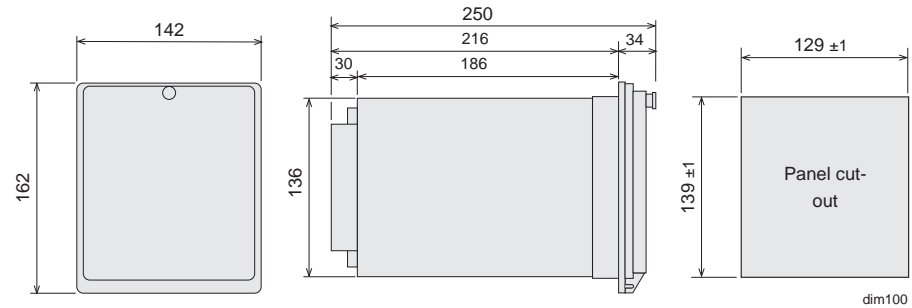

Fig. 2 Flush-mounting relay case (dimensions in mm)

Semi-flush mounting

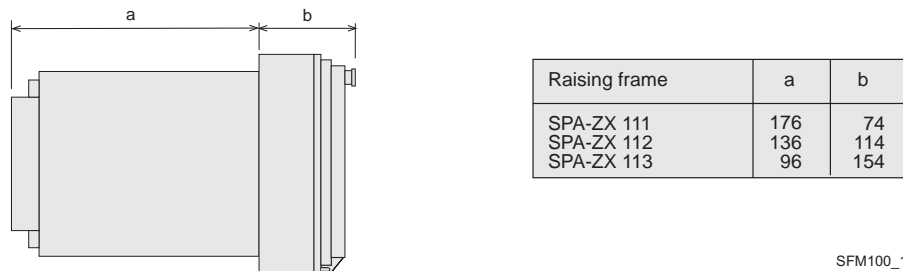

Fig. 3 Semi-flush mounting relay case (dimensions in mm)

Mounting in 19 inch cabinets and frames

An ancillary mounting plate, height 4U (~177 mm), is recommended to be used when the protection relays are to be mounted in 19 inch frames or cabinets. The ancillary mounting plate type SPA-ZX 104 accommodates three relays, type SPA-ZX 105 two relays and type SPA-ZX 106 one relay.

Projecting mounting

When projecting mounting is preferred, a relay case type SPA-ZX 110 is used. The relay case for projecting mounting is provided with front connectors.

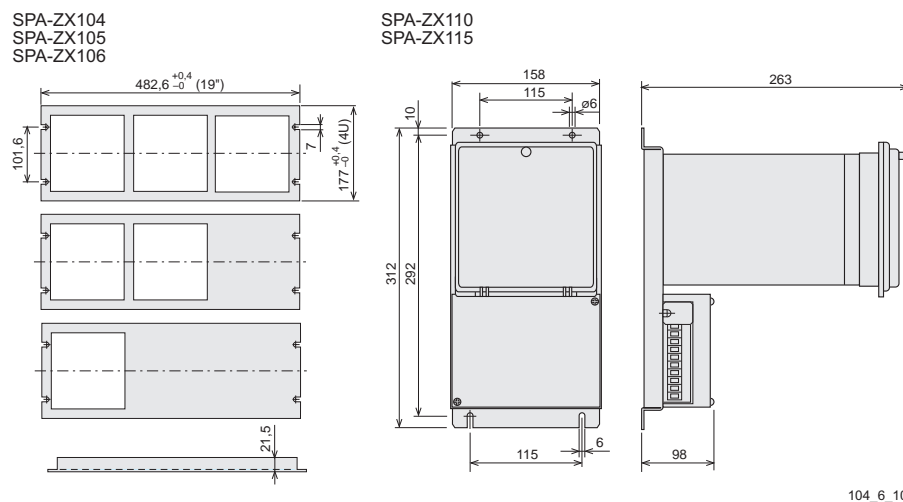

Fig. 4 Mounting cabinets and frames as well as projecting mounting (dimensions in mm)

104_6_10

Ordering

When ordering, please specify:

Ordering information	Ordering example
1. Type designation and quantity	SPAA 120 C, 5 pieces
2. Order number	RS 614 101-AA
3. Rated values	$I_n=5$ A, $U_n=110$ V, $f_n=50$ Hz
4. Auxiliary voltage	$U_{aux}=110$ V dc
5. Accessories	-
6. Special requirements	-

Order numbers

Feeder protection relay SPAA 120 C without test adapter	RS 614 101-AA, CA, DA, FA
Feeder protection relay SPAA 120 C including test adapter RTXP18	RS 614 201-AA, CA, DA, FA
The last two letters of the order number indicate the rated frequency f_n and the auxiliary voltage U_{aux} of the relay as follows:	AA equals $f_n = 50$ Hz and $U_{aux} = 80...265$ V ac/dc
	CA equals $f_n = 50$ Hz and $U_{aux} = 18...80$ V dc
	DA equals $f_n = 60$ Hz and $U_{aux} = 80...265$ V ac/dc
	FA equals $f_n = 60$ Hz and $U_{aux} = 18...80$ V dc

References

Additional information

Brochure "Feeder protection relays, SPAA 120 C, SPAA 121 C"	1MRS 750191-MDS EN
Manual "Feeder protection relay, SPAA 120 C, SPAA 121 C"	1MRS 750218-MUM EN



ABB Substation Automation Oy

P.O. Box 699

FIN-65101 Vaasa

Finland

Telephone: +358 10 224 000

Fax: +358 10 224 1094