

# Non-Metallic Systems

## Adaptaseal Type T



### Technical Characteristics

Conforms to	BSI Kitemark KM-35161 Low voltage directive		
Approvals and Standards			
Degree of mechanical protection	High Impact Resistance		
Degree of protection	IP66 - As standard IP67 - As standard IP68 - N/A IP69k - N/A		
UV protection	Very High		
Fitting Characteristics	3 way T - compression sealing system Black (BL) Only		
Application	For coupling three flexible conduits in a T configuration		
Normal operating temperature range	Application	Min Temp	Max Temp
	Static	- 50°C	+120°C
	Dynamic	- 45°C	+120 °C
For use with - Conduit Series	Light, Standard and Heavyweight variants of type <a href="#">PA</a> , <a href="#">PI</a> , <a href="#">CP</a> , <a href="#">PR</a> , <a href="#">PADL</a> & <a href="#">PE</a>		

Fire performance	Test Standard	Performance Rating	
	BS EN 61386-1 & 23	Approved	<b>Self Extinguishing Low Smoke &amp; Halogen Free</b>
	NFF16-101	I4 F2	
	ISO 4589-2	24%	
	BS EN 60695-2-11	850°C	
	UL94	V2	

Testing data [Click or See pages 3 & 4](#)

Type of material Polyamide (Nylon) 66 - Body - TPV Seal (up to 21mm fitting) / CR Seal (28mm fitting & larger)



The Company's policy is one of continuous improvement and reserves the right to change specifications at any time without prior notice.

# Non-Metallic Systems

## Adaptaseal Type T



### Dimensional & Thread Data

Part No	Nominal Conduit (mm)	Nominal Dimensions (mm)				Weight in grams (Each)
		A	B	C	D	
ASF10X3/T	13	68.5	50.0	38.7	26.8	22
ASF13X3/T	16	68.5	50.0	38.7	26.8	22
ASF16X3/T	16	69.5	50.5	37.6	30.7	26
ASF21X3/T	21	80.0	58.0	42.7	35.0	37
ASC21X3/T	21	80.0	58.0	42.7	35.0	37
ASF28X3/T	28	95.0	71.0	51.5	43.0	65
ASC28X3/T	28	95.0	71.0	51.5	43.0	65
ASF34X3/T	34	109.0	84.0	61.0	51.0	85
ASC34X3/T	34	109.0	84.0	61.0	51.0	85

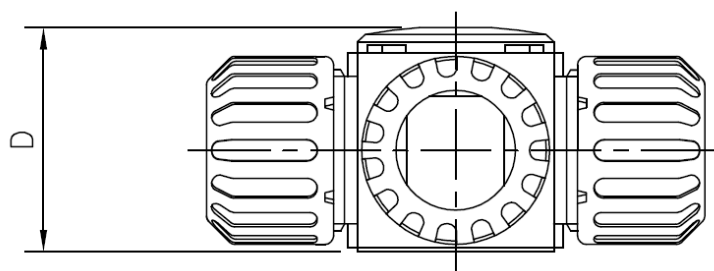
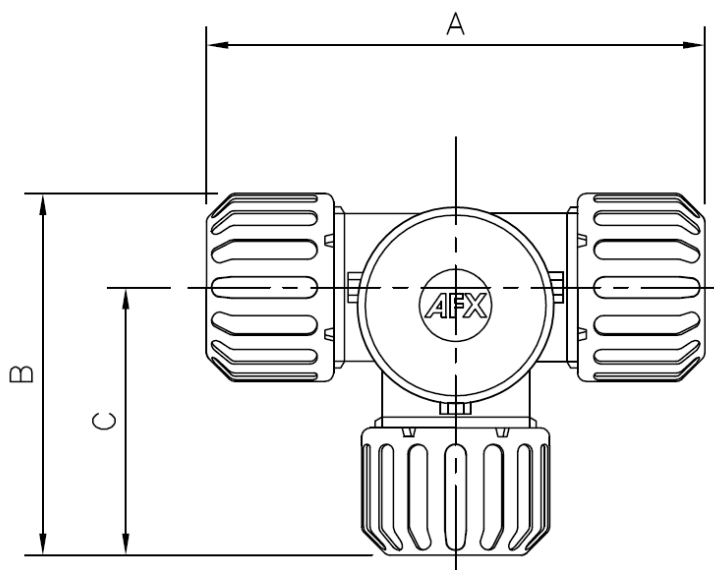

The Company's policy is one of continuous improvement and reserves the right to change specifications at any time without prior notice.

**Cable Management Products Ltd.**

CMG House - Station Road - Coleshill - B46 1HT - United Kingdom

Tel: +44(0)1675 468 222 - Fax: +44(0)1675 464 930

Technical Support e-mail: [cmg.conduitsystems@abb.com](mailto:cmg.conduitsystems@abb.com) - [www.adaptaflex.co.uk](http://www.adaptaflex.co.uk)

# Non-Metallic Systems

## Adaptaseal Type T



### BS EN 61386 Classification

	Fitting	Compression	Impact	Min temp	Max temp	bending	electrical	IP solids	IP water	Corrosion	Tensile	Non-flame Propogating	Suspended load
	AL	N/A	4	2	4	N/A	0	6	6	0	1	1	0

### Mechanical Properties

Test Type	Methods / Standards	Requirements	Value
Tensile Strength	IEC61386-1	2 mins at Specified Value ( <i>PAFS21 Conduit</i> )	Class 1
Tensile Strength		Ultimate Pullout ( <i>PAFS21 Conduit</i> )	240N
Impact Strength @ -45°C	IEC61386-1	No visible damage	Class 1
Impact Strength @ -5°C	IEC61386-1	No visible damage	Class 3
Impact Strength @ 23°C	IEC61386-1	No visible damage	Class 5

Tensile Tests to IEC 61386 gives the minimum classification value only. Actual values will depend on the type and size of the fittings used and will always be greater than the minimum – Impact strength is the minimum classification value at the minimum temperature – actual values will depend on size and temperature. Specific values available on request.

### Thermal Properties

Test Type	Methods / Standards	Requirements	Value
Dynamic Applications	IEC 61386-23	5000 Operations at MBR 2hrs	-45°C to +120°C
Static Short Term Temp		Temporary Use (3000hrs)	-50°C to +120°C
Static Long Term Temp		Permanent Use (30,000) Hours	-40°C to +105°C

The Company's policy is one of continuous improvement and reserves the right to change specifications at any time without prior notice.

**Cable Management Products Ltd.**

CMG House - Station Road - Coleshill - B46 1HT - United Kingdom  
 Tel: +44(0)1675 468 222 - Fax: +44(0)1675 464 930  
 Technical Support e-mail: [cmg.conduitsystems@abb.com](mailto:cmg.conduitsystems@abb.com) - [www.adaptaflex.co.uk](http://www.adaptaflex.co.uk)

# Non-Metallic Systems

## Adaptaseal Type T



### Flammability

Test Type	Method / Standard	Requirement	Result	Unit
Glow Wire	BS EN 60695-2-11	Extinguish within 30s	850°C	°C
Flammability	IEC 61386-1-12	1Kw Burner Flame to Self Extinguish	Pass	Pass/Fail
Oxygen Index	ISO 4589-2		24.1	%
Ignition Rating	NF F16-101	I Rating	I4	-

### Smoke

Test Type	Method / Standard	Requirement	Result	Unit
Fume Rating	NF F16-101	F Rating	F2	-

### Toxicity

Test Type	Method / Standard	Requirement	Result	Unit
Halogen Free	NFX 70-100	< 0.5%	Pass	Pass/Fail

### Pre Test Conditions

Duration	Standard	Temperature	Relative Humidity
168 (Hours)	IEC61386	23 (°C)	50 (%)

### Chemical Resistance Chart

Key:	<table border="1"> <tbody> <tr> <td>● Astm No.1</td> <td>● Diesel oil</td> <td>● Methyl Bromide</td> <td>● Sulphur Dioxide (Gas)</td> </tr> <tr> <td>● Astm No.2</td> <td>● Diethylamine</td> <td>● MEK</td> <td>● Sulphuric Acid (10%)</td> </tr> <tr> <td>● Astm No.3</td> <td>● Ethanol</td> <td>● Nitric Acid (10%)</td> <td>● Sulphuric Acid (70%)</td> </tr> <tr> <td>● Acetic Acid (10%)</td> <td>● Ether</td> <td>● Nitric Acid (70%)</td> <td>● Toluene</td> </tr> <tr> <td>● Acetone</td> <td>● Ethylamine</td> <td>● Oxalic Acid</td> <td>● Transformer Oil</td> </tr> <tr> <td>● Aluminium Chloride</td> <td>● Ethylene Glycol</td> <td>● Ozone (Gas)</td> <td>● 1,1,1-Trichloroethane</td> </tr> <tr> <td>● Aniline</td> <td>● Ethyl Ethanoate</td> <td>● Paraffin oil</td> <td>● Trichloroethylene</td> </tr> <tr> <td>● Benzaldehyde</td> <td>● Freon 32</td> <td>● Petrol</td> <td>● Turpentine</td> </tr> <tr> <td>● Benzene</td> <td>● Hydrochloric Acid (10%)</td> <td>● Phenol</td> <td>● Vegetable Oil</td> </tr> <tr> <td>● Carbon tetrachloride</td> <td>● Hydrochloric Acid (36%)</td> <td>● Sea Water</td> <td>● Vinyl Acetate</td> </tr> <tr> <td>● Chlorine water</td> <td>● Hydrogen Peroxide (35%)</td> <td>● Silver Nitrate</td> <td>● Water</td> </tr> <tr> <td>● Chloroform</td> <td>● Hydrogen Peroxide (87%)</td> <td>● Skydrol</td> <td>● White Spirit</td> </tr> <tr> <td>● Citric Acid</td> <td>● Lactic Acid</td> <td>● Sodium Chloride</td> <td>● Zinc Chloride</td> </tr> <tr> <td>● Copper Sulphate</td> <td>● Lubricating oil</td> <td>● Sodium Hydroxide (10%)</td> <td></td> </tr> <tr> <td>● Cresol</td> <td>● Methanol</td> <td>● Sodium Hydroxide (60%)</td> <td></td> </tr> </tbody> </table>				● Astm No.1	● Diesel oil	● Methyl Bromide	● Sulphur Dioxide (Gas)	● Astm No.2	● Diethylamine	● MEK	● Sulphuric Acid (10%)	● Astm No.3	● Ethanol	● Nitric Acid (10%)	● Sulphuric Acid (70%)	● Acetic Acid (10%)	● Ether	● Nitric Acid (70%)	● Toluene	● Acetone	● Ethylamine	● Oxalic Acid	● Transformer Oil	● Aluminium Chloride	● Ethylene Glycol	● Ozone (Gas)	● 1,1,1-Trichloroethane	● Aniline	● Ethyl Ethanoate	● Paraffin oil	● Trichloroethylene	● Benzaldehyde	● Freon 32	● Petrol	● Turpentine	● Benzene	● Hydrochloric Acid (10%)	● Phenol	● Vegetable Oil	● Carbon tetrachloride	● Hydrochloric Acid (36%)	● Sea Water	● Vinyl Acetate	● Chlorine water	● Hydrogen Peroxide (35%)	● Silver Nitrate	● Water	● Chloroform	● Hydrogen Peroxide (87%)	● Skydrol	● White Spirit	● Citric Acid	● Lactic Acid	● Sodium Chloride	● Zinc Chloride	● Copper Sulphate	● Lubricating oil	● Sodium Hydroxide (10%)		● Cresol	● Methanol	● Sodium Hydroxide (60%)	
● Astm No.1	● Diesel oil	● Methyl Bromide	● Sulphur Dioxide (Gas)																																																													
● Astm No.2	● Diethylamine	● MEK	● Sulphuric Acid (10%)																																																													
● Astm No.3	● Ethanol	● Nitric Acid (10%)	● Sulphuric Acid (70%)																																																													
● Acetic Acid (10%)	● Ether	● Nitric Acid (70%)	● Toluene																																																													
● Acetone	● Ethylamine	● Oxalic Acid	● Transformer Oil																																																													
● Aluminium Chloride	● Ethylene Glycol	● Ozone (Gas)	● 1,1,1-Trichloroethane																																																													
● Aniline	● Ethyl Ethanoate	● Paraffin oil	● Trichloroethylene																																																													
● Benzaldehyde	● Freon 32	● Petrol	● Turpentine																																																													
● Benzene	● Hydrochloric Acid (10%)	● Phenol	● Vegetable Oil																																																													
● Carbon tetrachloride	● Hydrochloric Acid (36%)	● Sea Water	● Vinyl Acetate																																																													
● Chlorine water	● Hydrogen Peroxide (35%)	● Silver Nitrate	● Water																																																													
● Chloroform	● Hydrogen Peroxide (87%)	● Skydrol	● White Spirit																																																													
● Citric Acid	● Lactic Acid	● Sodium Chloride	● Zinc Chloride																																																													
● Copper Sulphate	● Lubricating oil	● Sodium Hydroxide (10%)																																																														
● Cresol	● Methanol	● Sodium Hydroxide (60%)																																																														
Suitable :	●																																																															
Limited Suitability :	●																																																															
Unsuitable :	●																																																															
Not Tested :	●																																																															

The information above is given as a guide only and is based on published technical data and experience. The chemical resistance of the above products is dependant on factors such as chemical exposure, concentration of the chemical and temperature. The above chemicals are valid for a temperature of 23°C. Use of the above table is at the users own discretion and risk. Those using it must satisfy themselves that their application presents no health and safety risks. The end user should assess compatibility with their application and contact Thomas & Betts for further information.

ADHERENCE TO THE CURRENT WIRING REGULATIONS BS7671 OR NEC WIRING REGULATIONS (FOR USA) IS STRONGLY ADVISED.  
 MINIMUM BEND RADIUS FOR FLEXING IS DEPENDANT UPON MINIMUM TEMPERATURE, BENDING FREQUENCY AND CHEMICAL ENVIRONMENT.

The Company's policy is one of continuous improvement and reserves the right to change specifications at any time without prior notice.