

ERG120

INSTRUCTION SHEET FOR CABLE TIE INSTALLATION TOOL

1. Tool Description:

- **Purpose:** Specifically designed for the precise tensioning & clean trimming of Ty-Rap cable ties, making it ideal for use in electrical, automotive, and general industrial applications.
- **Applicable Cable Tie Sizes:** It supports cable tie widths ranging from 4.8 to 7.6 mm, covering a wide range of standard Ty-Rap sizes.
- **Automatic Cutting Mechanism:** The tool features a cutting mechanism that trims the cable tie flush to the head, while the tail remains securely captured within the tool for safe disposal.
- **Anti-Recoil Mechanism:** It includes an anti-recoil cut-off mechanism that enhances comfort by reducing the impact felt during the cutting process.
- **Quick Tension Adjustment:** The easy-access tension adjustment wheel allows for rapid setup up to 5 times faster than conventional tools. Eight distinct tension settings for precise control.
- **Tensioning Mechanism:** The adjustment wheel is conveniently located towards the front of the tool, allowing for quick and easy tension changes during operation.
- **Spare Blade:** Each tool comes equipped with a spare blade, which is securely stored in the designated spare blade nest for easy access when needed.
- **Compatible Materials:** This tool is designed to be compatible with all variants of Ty-Rap, ensuring versatility across different applications.
- **Tool Type & Life Cycle:** This is a manual tool with a robust design, capable of delivering approximately 150,000 operational cycles under normal usage conditions.
- **Ambidextrous Operation:** Ergonomically designed to accommodate both right and left handed users, ensuring comfortable & efficient use regardless of dominant hand preference.

2. Safety Precautions:

- **Eye Protection:** Always wear safety glasses while operating the tool to protect your eyes from flying debris or accidental contact.
- **Hand Safety:** Keep your fingers and hands safely away from the trimming area to avoid injury during operation.
- **Tool Inspection:** Thoroughly inspect the tool before each use to check for any signs of wear, damage, or malfunction.
- **Work Environment:** Ensure you are working in a well-lit environment to maintain clear visibility and reduce the risk of accidents.
- **Glove Use:** Wearing protective gloves is strongly recommended to safeguard your hands from sharp edges and potential hazards.

3. Parts Identification:

The diagram below illustrates the key components of the Ty-Rap cable tie application tool, each designed to enhance performance, comfort, and precision. Items are numbered from 1 to 8, with corresponding descriptions provided in the table to help users identify and understand the function of each part.



Item No.	Component Name	Description
1	360° rotating stainless steel nose	Allows flexible tool positioning for improved access in tight spaces.
2	Interchangeable nose	Enables quick replacement or customization for different cable tie sizes or applications.
3	Tension adjustment lock	Secures the selected tension setting to prevent accidental changes during use.
4	Tension adjustment wheel	Used to fine-tune the tension level for precise cable tie application.
5	High/low force setting	Lets the user switch between high and low force modes depending on the application.
6	Adjustable handle span	Customizes the handle spacing for user comfort and ergonomic fit.
7	Spare blade nest	Built-in compartment for storing an extra cutting blade for quick replacement.
8	Anti-recoil cut-off mechanism	Reduces recoil during cutting to enhance user comfort and control.

4. Operating Instructions:

- **Selecting the Proper Setting:** Before inserting the cable tie, ensure the tool is set to the correct tension level for your application. Use the tension adjustment wheel to select the appropriate setting based on cable size and material.
- **Inserting the Cable Tie:** Insert the cable tie into the tool’s feed slot until it reaches the head of the tie. Make sure it is properly seated and aligned to ensure smooth operation.
- **Applying Tension:** Squeeze the handle gradually to apply tension to the cable tie. Adjust the tension as needed using the wheel to suit your specific bundling requirements.
- **Trimming Excess:** Once the desired tension is achieved, continue squeezing the handle to automatically trim the excess tail of the cable tie. The tool resets itself after trimming, ready for the next use. **Please handle trimmed cable tie waste responsibly and dispose of it according to your local recycling or waste regulations. Think about the environment.**

See below pictures 1 to 6, for more details and visual explanation:

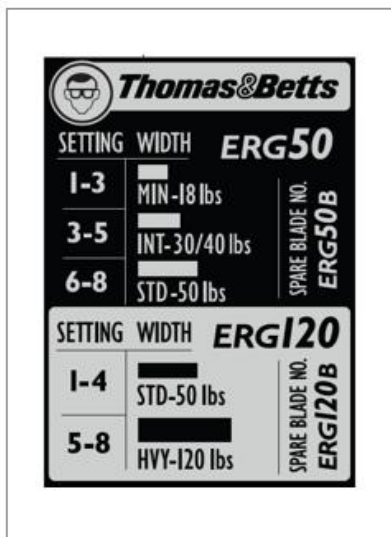

01

Selecting Proper Setting: Refer to the tool label located on the top of the device to determine the correct setting based on the cable tie’s width and tensile strength. The label provides eight distinct settings to ensure optimal performance for various tie specifications.



02

Adjusting Tension: Rotate the tension adjustment wheel to align with the selected setting. This ensures the tool applies the appropriate force during operation, tailored to the specific cable tie being used.

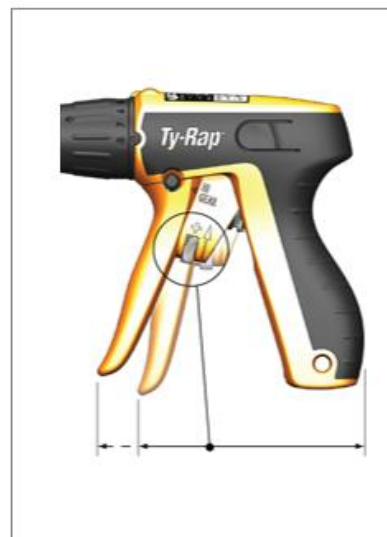

03

Setting Handle Span: Use the span adjustment wheel located between the two handles to modify the handle spacing. This feature allows comfortable use of the tool for operators with different hand sizes, improving ergonomics and control.

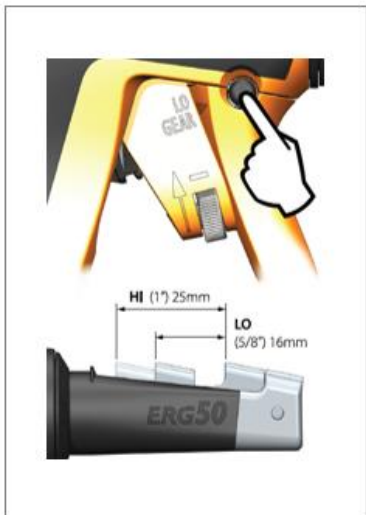

04

Configuring Stroke Settings: If needed, adjust the stroke configuration by pressing the designated buttons on the tool.

Choose between “high force & long stroke” or “low force & short stroke” depending on the application requirements and user preference.



05

Positioning the Tool: Rotate the 360° adjustable nose to orient the tool in the desired working position. This flexibility allows efficient operation in tight or angled spaces without compromising precision.



06

Fastening the Cable Tie: Press the handle to apply the cable tie securely around the cable bundle. The tool will automatically tension and trim the excess tail, resetting itself for the next use.

Additional information: Each tool is supplied with a spare blade located in the handle. Blades should be replaced after approximately 30,000 operations to maintain optimal performance.

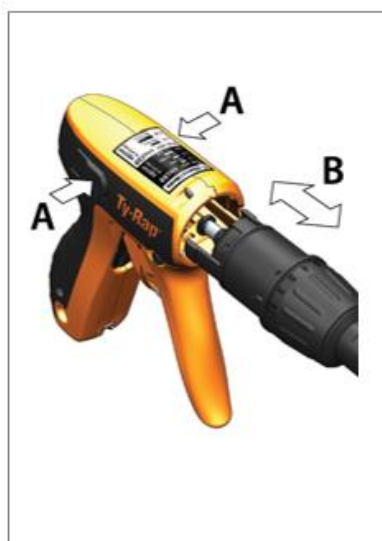

07

Remove the Tool Nose Assembly: Identify parts A and B on the tool nose. Turn these components to detach the nose section, giving access to internal components including the blade housing.



08

Unlock the Tension Setting Lock: Use a 1.5 mm (1/16 inch) L-shaped hexagonal key. Insert the key into the designated slot to release the tension setting lock, which secures the blade and other internal parts.



09

Replace the Blade: Carefully remove the old blade from its position. Retrieve the spare blade stored in the handle nest. Insert the new blade into the tool nose, ensuring it is properly seated and locked in place.

5. Maintenance & Adjustment Instructions:

- **Tension Adjustment:** To increase the tension, rotate the adjustment knob clockwise. To reduce the tension, rotate the knob counterclockwise until the desired setting is achieved.
- **Cleaning:** Wipe the exterior of the tool using a dry cloth to remove dust and surface debris. Use compressed air to clean out any internal particles or buildup. Do not submerge the tool in liquids, as this may damage internal components.
- **Blade Replacement:** Begin by removing the screws on the blade housing to access the cutting blade. Replace the old blade with an OEM replacement. After installation, reassemble the housing and test the tool to ensure proper functionality before use.
- **Lubrication:** Periodically apply a small amount of light machine oil to moving parts such as the tensioning arm and trigger mechanism to maintain smooth operation and reduce wear.

- **Storage:** Store the tool in a clean, dry environment when not in use. Avoid exposure to moisture, dust, or extreme temperatures to prolong the tool's lifespan.
- **Inspection:** Regularly inspect the tool for signs of wear, damage, or loose components. Pay special attention to the blade, tensioning mechanism, and handle grip.
- **Calibration Check:** If the tool is used in precision-critical environments, periodically verify the tension settings against a known standard to ensure consistent performance.
- **Handle Adjustment:** Use the adjustable handle span feature to set the most comfortable grip width for the user, reducing fatigue during extended use.

6. Troubleshooting Guide:

Problem	Possible Cause	Solution
Tie not cutting cleanly	Blade is dull	Replace blade
Excessive tension needed	Tie misaligned	Reinsert and retry
Tool not resetting	Spring mechanism jam	Disassemble and inspect
Inconsistent tension	Tension wheel loose	Tighten the tension wheel
Handle feels stiff	Lack of lubrication	Apply light machine oil to moving parts
Trigger not engaging	Internal blockage	Clean tool and remove any obstructions
Blade not moving	Blade housing misaligned	Reassemble blade housing correctly

7. Technical Specifications:

Parameter	Value
Min Tie Width	4.8 mm
Max Tie Width	7.6 mm
Tension Range	222 to 534 N
Operating Temp	-30°C to 80°C
Weight	~400 g
Material	Aluminum / Composite body
Tool Type	Manual
Cycle Life	Approx. 150,000 cycles
Cutting Mechanism	Automatic flush cut
Handle Adjustment	Yes – Adjustable span of 25.4 mm
Tension Settings	8-position adjustment wheel
Force Mode	High/Low switchable
Blade Type	Replaceable (OEM Part No: ERG120B)
Spare Blade Storage	Integrated compartment
Noise Level	Ultra-quiet operation – virtually silent

8. Tension Settings:

The below table provides approximate force ranges for each tension setting on ERG120 tool head. These values help select the correct tension level based on the application & cable tie type.

Refer to this table when adjusting the tension wheel to ensure optimal performance:

Tension Setting	Force min – max [N]
Position 1	175 - 250
Position 2	214 - 297
Position 3	253 - 344
Position 4	292 - 391
Position 5	331 - 438
Position 6	370 - 485
Position 7	411 - 533
Position 8	450 - 580

9. Notes & Warranty:

- **1-Year Limited Warranty:** This tool is covered by a one-year limited warranty, which protects against defects in materials and workmanship under normal use conditions.
- **Use of Original Parts:** To ensure optimal performance and maintain warranty coverage, only original manufacturer replacement parts should be used for repairs or maintenance.
- **Intended Use Only:** The tool is designed specifically for use with Ty-Rap cable ties. Using it with incompatible materials may result in damage and void the warranty.
- **Regular Maintenance Required:** Routine inspection, cleaning, and blade replacement are recommended to maintain tool performance and extend its service life.
- **Warranty Exclusions:** The warranty does not cover damage caused by misuse, unauthorized modifications, or failure to follow operating instructions.

10. Support Contact:

For product-related inquiries or technical assistance, please refer to the following contact:

- **EU Fastening Engineering Support Team**
 - For technical support and application-specific guidance within the EU region
 - **Contact Email: Gb-eu-fastening-engineering-support@abb.com**