

NOTES:

1. **WARNING:** This drawing does not illustrate completely the installation methods required for hazardous locations. Prior to any installation in a Classified Hazardous Location, verify installation methods by the Control Drawing referenced on the product's name tag and national and local codes.
2. To access termination boards, remove the front cover of the Junction Box for each unit.

Installations in a hazardous location will require a barrier. SEE NOTE 1

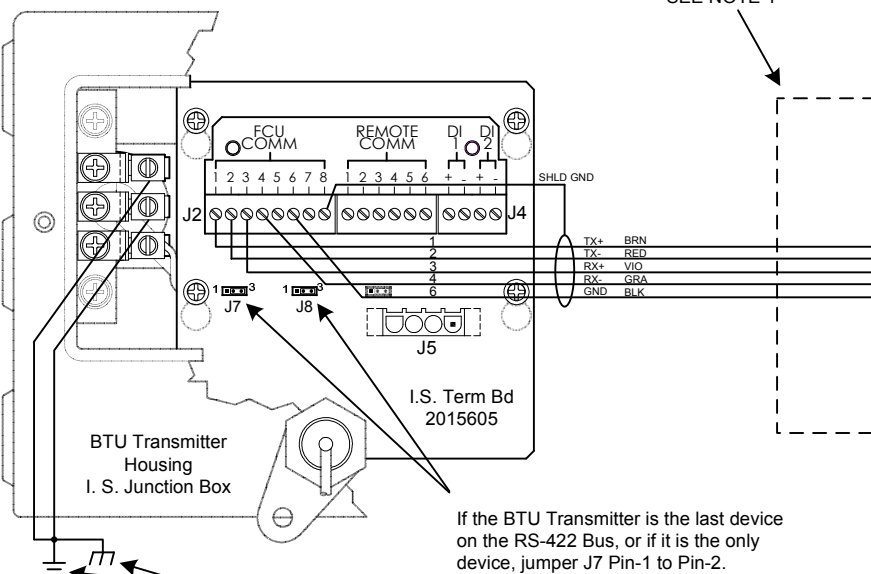

If the BTU Transmitter is the last device on the RS-422 Bus, or if it is the only device, jumper J7 Pin-1 to Pin-2.

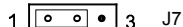

If it is not the last device, jumper J7 Pin-2 to Pin-3 (Pin-1 is on the left, when viewing the I.S. Board).

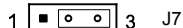

For RS-485 2-wire, jumper J8 Pin-1 to Pin-2. For RS-422 4-wire, jumper J8 Pin-2 to Pin-3

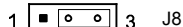

3. Redundant Ground Wires per ISA RP 12.6
Wires Must be GRN 12 AWG.
Ground Electrode per CEC C22.1 or NEC NFPA 70
4. Maximum accumulated length for RS-422 Bus is 4000 ft.
5. Unless it is configured for this application already, Switch 1 may have default settings:

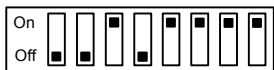

To access Patton Converter Switch settings, remove enclosure front cover and unscrew the converter to turn it over.

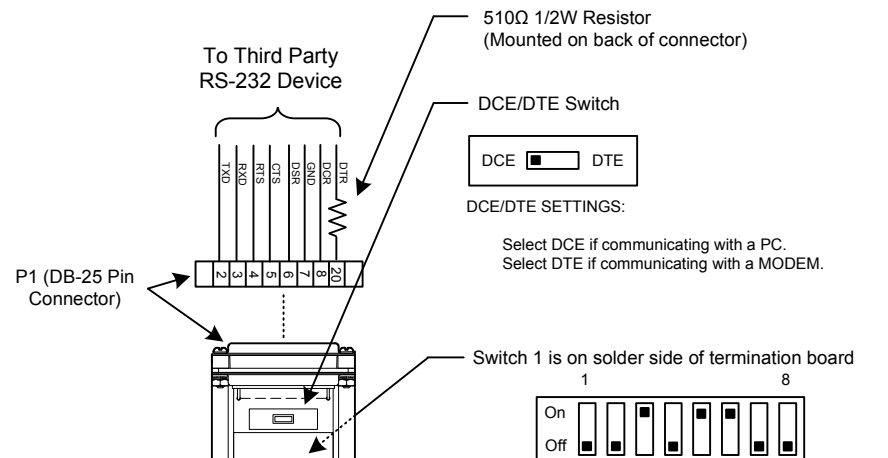

510Ω 1/2W Resistor (Mounted on back of connector)

DCE/DTE Switch

DCE DTE

DCE/DTE SETTINGS:
Select DCE if communicating with a PC.
Select DTE if communicating with a MODEM.

Switch 1 is on solder side of termination board

- SWITCH 1 SETTINGS (SEE NOTE 5):
- 1 & 2: Sets whether the receiving device sees the impedance of the converters transmitter as being "High" or "Intermediate" when the Transmitter is turned Off.
1 & 2 ON = Intermediate impedance.
1 & 2 OFF = High Impedance.
 - 3: Determines the delay between the time the converter see "RTS" and sends "CTS".
3 ON = 8 msec.
3 OFF = No delay
 - 4: Determines whether the converter echoes data back to the transmitting device.
4 ON = Echo ON (Half-duplex only)
4 OFF = Echo OFF
 - 5: Determines whether the Carrier is always ON, or controlled by "RTS".
5 ON = Controlled by "RTS"
5 OFF = Constantly ON
 - 6: Selects the impedance of the Input Receiver.
6 ON = Low (120 Ohm)
6 OFF = High (16 kOhm)
 - 7 & 8: Determines whether the converter is 2-wire (2-wire is half-duplex) or 4-wire.
7 & 8 ON = 2-wire mode.
7 & 8 OFF = 4-wire mode.

RS232/485 PATTON CONVERTER #2085F P/N 2015445-002

Totalflow Cable P/N 2011648 Or Use 20 AWG shielded wire, 22 pF/ft, 14 OHMs/1000 ft