



## The Company

We are an established world force in the design and manufacture of instrumentation for industrial process control, flow measurement, gas and liquid analysis and environmental applications.

As a part of ABB, a world leader in process automation technology, we offer customers application expertise, service and support worldwide.

We are committed to teamwork, high quality manufacturing, advanced technology and unrivalled service and support.

The quality, accuracy and performance of the Company's products result from over 100 years experience, combined with a continuous program of innovative design and development to incorporate the latest technology.

The UKAS Calibration Laboratory No. 0255 is just one of the ten flow calibration plants operated by the Company, and is indicative of our dedication to quality and accuracy.

EN ISO 9001:2000



Cert. No. Q5907

EN 29001 (ISO 9001)



Lenno, Italy – Cert. No. 9/90A

## Electrical Safety

This equipment complies with the requirements of CEI/IEC 61010-1:2001-2 'Safety Requirements for Electrical Equipment for Measurement, Control and Laboratory Use'. If the equipment is used in a manner NOT specified by the Company, the protection provided by the equipment may be impaired.

## Symbols

One or more of the following symbols may appear on the equipment labelling:

	<b>Warning</b> – Refer to the manual for instructions
	<b>Caution</b> – Risk of electric shock
	Protective earth (ground) terminal
	Earth (ground) terminal

	Direct current supply only
	Alternating current supply only
	Both direct and alternating current supply
	The equipment is protected through double insulation

Information in this manual is intended only to assist our customers in the efficient operation of our equipment. Use of this manual for any other purpose is specifically prohibited and its contents are not to be reproduced in full or part without prior approval of the Technical Communications Department.

### Health and Safety

To ensure that our products are safe and without risk to health, the following points must be noted:

1. The relevant sections of these instructions must be read carefully before proceeding.
2. Warning labels on containers and packages must be observed.
3. Installation, operation, maintenance and servicing must only be carried out by suitably trained personnel and in accordance with the information given.
4. Normal safety precautions must be taken to avoid the possibility of an accident occurring when operating in conditions of high pressure and/or temperature.
5. Chemicals must be stored away from heat, protected from temperature extremes and powders kept dry. Normal safe handling procedures must be used.
6. When disposing of chemicals ensure that no two chemicals are mixed.

Safety advice concerning the use of the equipment described in this manual or any relevant hazard data sheets (where applicable) may be obtained from the Company address on the back cover, together with servicing and spares information.



The COMMANDER 500 can be configured and made ready for operation in three easy steps. This 'Getting Started' guide provides an overview of these steps and, where necessary, refers to the relevant section of the manual.

**Step 1 – Decide on the Application Template and the Output Configuration required**

**Step 2 – Connect the process inputs and outputs**

**Step 3 – Power up the instrument, set the template number and the output configuration details**

*Your COMMANDER 500 is now ready for operation*

### **Step 1 – Application Template and Output Configuration**

- Choose the Template which best suits your application from the list in Table A, located on the rear fold-out.
- Choose the Control Output Type required from the list of options in Table B on the rear foldout.

### **Step 2 – Electrical Connections**

Using the labels on the back of the instrument as a guide, connect the process inputs, outputs and power supplies. Refer to Section 5.2 of this manual (Electrical Installation) for more information.

*Continued...*



## GETTING STARTED

### Step 3 – Setting the Parameters (Fig. GS.1)



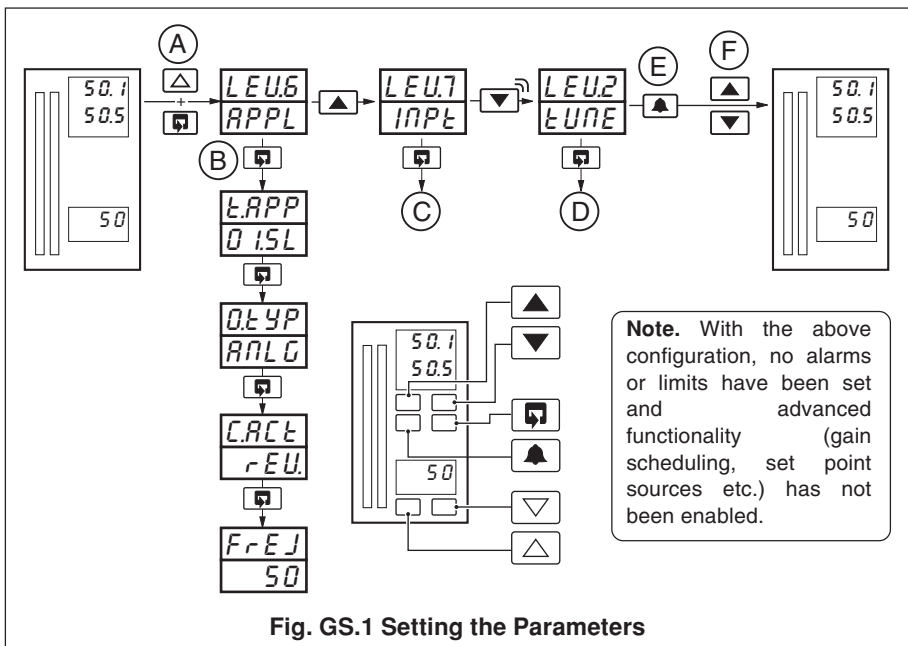

- (A) Power-up the instrument. Press the and keys simultaneously and hold for 3 seconds to advance directly to Level 6 – Basic Configuration.
- (B) Set the appropriate application template, output type and control action. Use the key to advance between frames and upper and keys to adjust the default values – see Section 4.2 for further information.
- Note.** When the output type has been selected, the available inputs and outputs default to the settings shown in Table B on the rear fold-out.
- (C) If you are not using 4 to 20mA inputs, then select Level 7 using the upper and keys and set up Analog Inputs I/P1 to I/P3 to suit your process – see Section 4.3.
- (D) Controller templates only:  
Select Level 2 using the upper and keys and set the tune parameters:
- **Analog or Motorized Valve Control** – set the Proportional, Integral and Derivative terms.
  - **Time Proportioning Control** – set the Cycle Time, Hysteresis and P, I & D Terms
  - **Heat/Cool Outputs** – set the points at which the Output 1 and Output 2 become active.
- (E) Press to return to the Operating displays.
- (F) Adjust the set point to the required value.

*Your COMMANDER 500 is now in operation*





# OVERVIEW

This manual is divided into 5 sections which contain all the information needed to install, configure, commission and operate the COMMANDER 501 Process Controller. Each section is identified clearly by a symbol as shown in Fig. 1.

	<b>Displays and Controls</b> <ul style="list-style-type: none"><li>• Displays and Function Keys</li><li>• LED Indication</li><li>• Error Messages</li></ul>		<b>Configuration Mode (Levels 6 to E)</b> <ul style="list-style-type: none"><li>• Level 6 – Basic Configuration</li><li>• Level 7 – Input Configuration</li><li>• Level 8 – Alarm Configuration</li><li>• Level 9 – Set Point Configuration</li><li>• Level A – Control Configuration</li><li>• Level B – Operator Configuration</li><li>• Level C – Output Configuration</li><li>• Level D – Serial Communications</li><li>• Level E – System Calibration</li></ul>
	<b>Operator Mode (Level 1)</b> <ul style="list-style-type: none"><li>• Single Loop Controller</li><li>• Motorized Valve Controller</li><li>• Auto/Manual &amp; Backup Stations</li></ul>		
	<b>Set Up Mode (Levels 2 to 5)</b> <ul style="list-style-type: none"><li>• Level 2 – Tuning</li><li>• Level 3 – Set Points</li><li>• Level 4 – Alarm Trip Points</li><li>• Level 5 – Valve Setup</li></ul>		<b>Installation</b> <ul style="list-style-type: none"><li>• Siting</li><li>• Mounting</li><li>• Electrical Connections</li></ul>

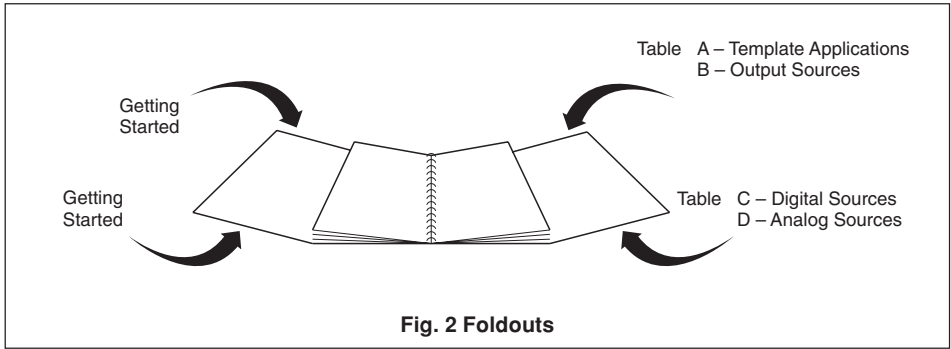
**Fig. 1 Overview of Contents**

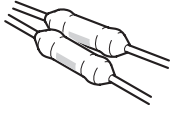
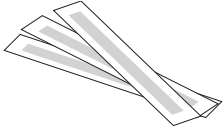
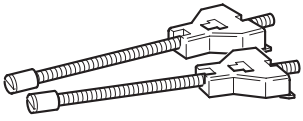

			
<b>Shunt Resistors</b> 2 x 100Ω (+1 optional)	<b>Process Labels</b> x3	<b>Panel Clamps</b> x2	<b>CJ Sensor</b> x1 (+1 optional)

**Fig. 3 Accessories**

# CONTENTS

Section	Page	Section	Page
<b>OVERVIEW</b> .....	<b>1</b>	<b>5 INSTALLATION</b> .....	<b>71</b>
<b>1 DISPLAYS AND FUNCTION KEYS</b> .....	<b>3</b>	5.1 Mechanical Installation .....	71
1.1 Introduction .....	3	5.2 Electrical Installation .....	76
1.2 Use of Function Keys .....	4	5.3 Relays .....	79
1.3 Secret-til-Lit Indicators .....	8	5.4 Digital Output .....	79
1.4 Character Set .....	8	5.5 Control or Retransmission Analog Output .....	79
1.5 Error Messages .....	9	5.6 Motorized Valve Connections .....	80
1.6 Processor Watchdog .....	10	5.7 Input Connections .....	80
1.7 Loop Break Monitor .....	10	5.8 Output Connections .....	81
1.8 Glossary of Abbreviations .....	10	5.9 Power Supply Connections .....	81
<b>2 OPERATOR LEVEL</b> .....	<b>11</b>	<b>SPECIFICATION</b> .....	<b>82</b>
2.1 Introduction .....	11	<b>APPENDIX A – CONTROL TEMPLATES</b> ..	<b>84</b>
2.2 Single Loop Controller (Templates 1 and 2) .....	12	A1 Single Loop Controller (Templates 1 and 2) .....	85
2.3 Auto/Manual Station (Templates 3 and 4) .....	14	A2 Auto/Manual Station and Analog Backup Station .....	86
2.4 Analog Backup (Templates 5 and 6) .....	16	A3 Indicator/Manual Loader Station (Templates 7 and 8) .....	89
2.5 Indicator/Manual Loader Station (Templates 7 and 8) .....	18	B4 Six Logic Equations .....	90
2.6 Heat/Cool Output Types .....	19	<b>APPENDIX B – COMMANDER CONFIGURATION EDITOR</b> .....	<b>90</b>
2.7 Motorized Valve Output Types .....	20	B1 Introduction .....	90
2.8 Auto-tune .....	21	B2 Analog Input Customization .....	90
2.9 Control Efficiency Monitor .....	24	B3 Four Programmable Maths Blocks .....	90
<b>3 SET UP MODE</b> .....	<b>27</b>	B5 Process Alarm Customization .....	90
3.1 Introduction .....	27	B6 Two Real Time Alarms .....	90
3.2 Level 2 – Tune .....	28	B7 Two Delay Timers .....	90
3.3 Level 3 – Set Points .....	32	B8 Two Custom Linearizers .....	91
3.4 Level 4 – Alarm Trip Points .....	34	B9 Template Customization .....	91
3.5 Level 5 – Valve Setup .....	35	B10 Connecting the COMMANDER PC Configurator ...	91
<b>4 CONFIGURATION MODE</b> .....	<b>38</b>	<b>FRAMES INDEX</b> .....	<b>92</b>
4.1 Introduction .....	38	<b>INDEX</b> .....	<b>95</b>
4.2 Level 6 – Basic Configuration .....	39		
4.3 Level 7 – Analog Inputs .....	43		
4.4 Level 8 – Alarms .....	47		
4.5 Level 9 – Set Point Configuration ..	51		
4.6 Level A – Control Configuration ....	54		
4.7 Level B – Operator Configuration ..	59		
4.8 Level C – Output Assignment Configuration .....	61		
4.9 Level D – Serial Communications Configuration .....	67		
4.10 Level E – Calibration .....	68		

## 1.1 Introduction

The COMMANDER 500 front panel displays, function keys and LED indicators are shown in Fig. 1.1.

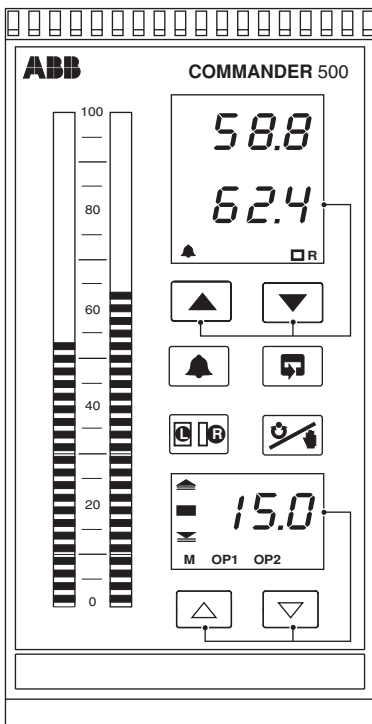

### Function Keys









Raise			Lower
Alarm Acknowledge			Parameter Advance
Local/Remote			Auto/manual
Up			Down

Fig. 1.1 Front Panel Displays and Function Keys

1.2 Use of Function Keys

**A – Raise and Lower Keys**

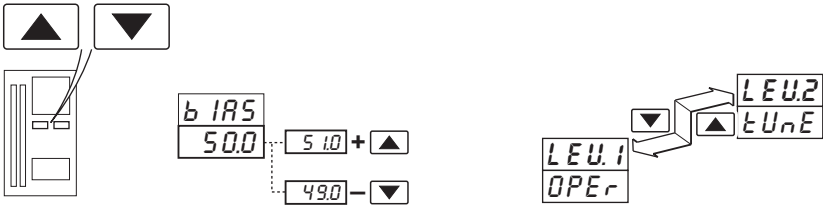

Use to change/set a parameter value... and... ...move between levels

**B – Up and Down Keys**

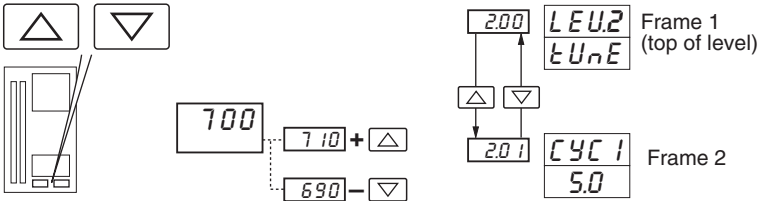

Use to adjust the output value... and... ...move between frames within a Setup or Configuration level. Any changes made on the current frame are stored when the next frame is selected.

**C – Parameter Advance Key**

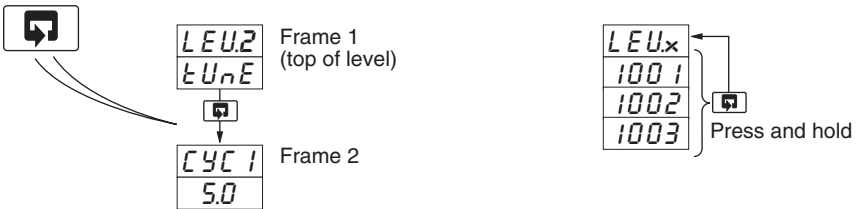

Use to advance to the next frame within a level... or... ...select the top (LEV.x) frame from within a level

**Note.** This key also stores any changes made in the previous frame

**D – Auto/Manual Key**

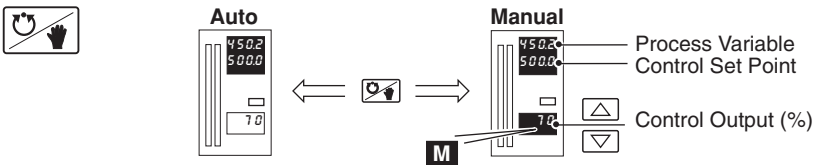

Use to select Auto or Manual control mode

Fig. 1.2a Use of Function Keys



## ...1.2 Use of Function Keys

## E – Alarm Acknowledgement

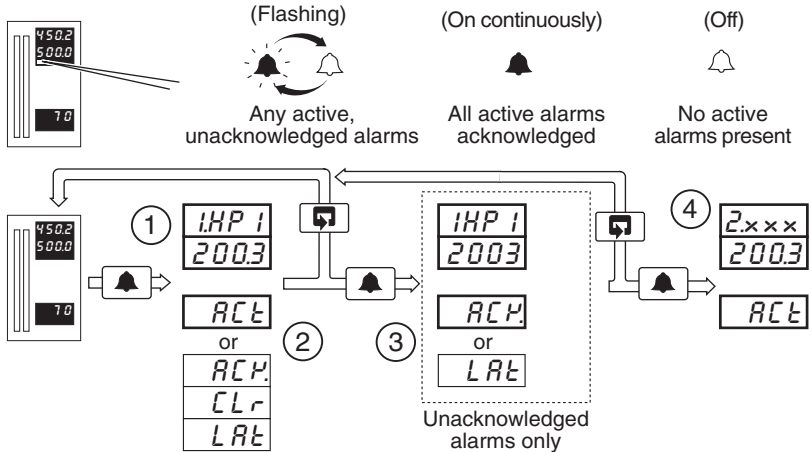

**Note.** If no alarms have been enabled in the Set Up level, pressing the key has no effect.

- ① The first active and unacknowledged alarm is displayed (or if no alarms are active, the first enabled alarm is displayed)

<i>HPU</i>	High Process, PV	<i>HO</i>	High Output
<i>LPU</i>	Low Process, PV	<i>LO</i>	Low Output
<i>HLP</i>	High Latch, PV	<i>PFL</i>	Power Failure Time – <b>See Note</b>
<i>LLP</i>	Low Latch, PV	<i>Hb1</i>	Maths Block 1 High
<i>Hd</i>	High Deviation	<i>Lb1</i>	Maths Block 1 Low
<i>Ld</i>	Low Deviation	<i>Hb2</i>	Maths Block 2 High
<i>HP1</i>	High Process I/P1	<i>Lb2</i>	Maths Block 2 Low
<i>LP1</i>	Low Process I/P1	<i>Hb3</i>	Maths Block 3 High
<i>HP2</i>	High Process I/P2	<i>Lb3</i>	Maths Block 3 Low
<i>LP2</i>	Low Process I/P2	<i>Hb4</i>	Maths Block 4 High
<i>HP3</i>	High Process I/P3	<i>Lb4</i>	Maths Block 4 Low
<i>LP3</i>	Low Process I/P3		

**Note.** The time of the power failure, *PFL*, is shown in the set point display.

- ② The lower display shows alarm status:  
*ACT* Alarm active and unacknowledged  
*ACK* Alarm active and acknowledged  
*CLR* Cleared or Inactive alarm  
*LAL* Unacknowledged latched alarm
- ③ Pressing again acknowledges the displayed alarm. Lower display changes to reflect new status.
- ④ Next active and unacknowledged alarm is displayed. If no alarms are active, the next enabled alarm is displayed.

Fig. 1.2b Use of Function Keys

...1.2 Use of Function Keys

**F – Local / Remote Key**

**Changing between Local and Remote Set Points**

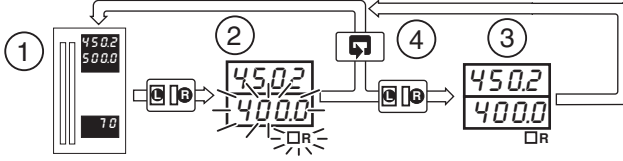

- ① Process variable and local set point displayed on red and green displays.
- ② Remote set point value is displayed. The value and □R symbol flash to indicate local set point still selected.
- ③ Remote set point selected.
- ④ Remote selection aborted.

**Note.** When an Analog Backup Station template is selected, the key is used to switch between local and remote mode – see Sections 2.4 and 4.2.

**Selecting Local Set Points 1 to 4**

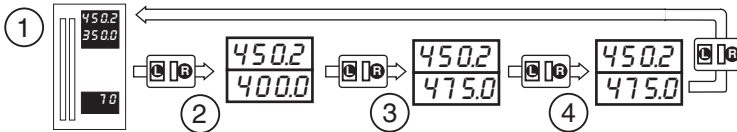

- ① Process variable and local set point 1 displayed.
- ② Process variable and local set point 2 displayed
- ③ Process variable and local set point 3 displayed
- ④ Process variable and local set point 4 displayed

**Fig. 1.2c Use of Function Keys**

## ...1.2 Use of Function Keys

## G – Short-cut Keys



LEUR  
CntL



LEU.1  
OPER

Press to move from anywhere in the Configuration level to the first frame in the Operator level



Press simultaneously and hold for 3 seconds – See Note

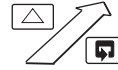
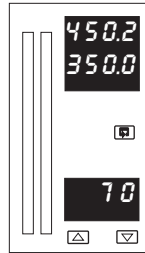

LEU6  
APPL

Press to move from anywhere in the Operator or Setup levels to the first page of the Configuration level

**Note.** This short-cut key operates only when the Configuration password is set to '0'.

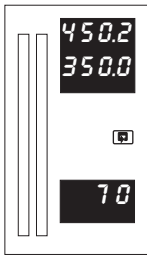

CODE  
0

Press and hold to move from the Operator Level to the Security Code Frame and then to other levels:

Tune Level – See Section 2.13.3

Set Up Level – See Fig. 3.1

Configuration Level – See Fig. 4.1

Fig. 1.2d Use of Function Keys

1.3 Secret-til-Lit Indicators

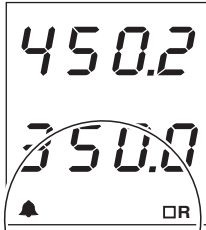

	Flashing	ON	OFF
	One or more alarms active and unacknowledged	All active alarms acknowledged	No alarms active
		Remote or Cascade set point in use	Local set point in use

A – Upper Display

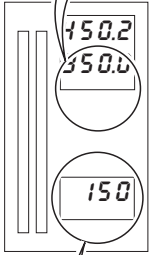

	Flashing	ON	OFF
<b>M</b>	Autotune in progress	Manual control selected	Auto control selected
<b>OP1</b>		Output 1 (heat) value displayed	
<b>OP2</b>		Output 2 (cool) value displayed	
		Valve opening	
		Valve stopped	
		Valve closing	

B – Lower Display

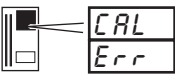



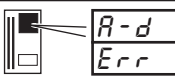
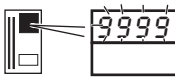
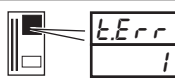

Fig. 1.3 Secret-til-lit Indicators

1.4 Character Set – Fig. 1.4

A	<i>R</i>	I	<i>l</i>	R	<i>r</i>
B	<i>b</i>	J	<i>J</i>	S	<i>S</i>
C	<i>C</i>	K	<i>K</i>	T	<i>t</i>
D	<i>d</i>	L	<i>L</i>	U	<i>U</i>
E	<i>E</i>	M	<i>-</i>	V	<i>U</i>
F	<i>F</i>	N	<i>n</i> Or <i>n</i>	Y	<i>y</i>
G	<i>G</i>	O	<i>O</i>		
H	<i>H</i>	P	<i>P</i>		

Fig. 1.4 Character Set

## 1.5 Error Messages

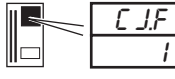
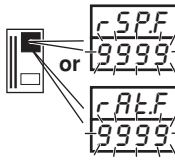
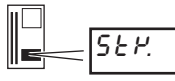
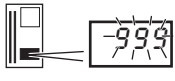
Display	Error/Action	To clear the display:
	<b>Calibration Error</b> Turn mains power off and on again (if the error persists contact the Customer Support Organization).	Press the  key
	<b>Non-volatile Memory Error</b> x = 1, 2: Motherboard Memory x = 3: Option Board Memory Turn mains power off and on again (if the error persists, check configuration/setup settings).	Press the  key
	<b>A to D Converter Fault</b> The analog to digital converter is not communicating correctly.	Contact the Customer Support Organization
	<b>Input Value Over/Under Range</b>	Restore valid input
	<b>Auto-tune Error</b> The number displayed indicates the type of error present – see Table 2.1 on page 30.	Press the  key
	<b>Cold Junction Failed</b> Cold junction sensor is faulty or has not been fitted correctly.	Check connections or replace if faulty.
	<b>Remote Set Point or External Ratio Failed.</b> Remote set point input value is over or under-range. Only appears if the remote set point (or external ratio) is displayed or in use.	Restore valid input
	<b>Valve Sticking</b> Motorized valve not moving at the speed expected. Valve may be sticking.	Check that the correct Regulator Travel Time has been set – see Section 3.5. Check the valve.
	<b>Position Feedback Fail</b> Input value is over- or under-range. Only appears if output type set to 'PFb' – motorized valve with feedback.	Restore valid input

### 1.6 Processor Watchdog

The instrument's processor activity is monitored by an independent watchdog device. When the output of the watchdog is assigned to a relay or digital output, the relay/digital output de-energizes if the instrument fails to function correctly.

### 1.7 Loop Break Monitor

Both analog outputs are monitored continuously to detect a loop break. A warning signal or other action can be initiated by assigning the loop break signals to relays or digital outputs.

### 1.8 Glossary of Abbreviations

Abbreviation	Description	Abbreviation	Description
PV	Process Variable	di1	Digital Input 1
LSPt	Local Set Point Value	di2	Digital Input 2
LSP1	Local Set Point 1 Value	di3	Digital Input 3
LSP2	Local Set Point 2 Value	di4	Digital Input 4
LSP3	Local Set Point 3 Value	ao1	Analog Output 1
LSP4	Local Set Point 4 Value	ao2	Analog Output 2
CSPt	Control Set Point Value	do1	Digital Output 1
RSPt	Remote Set Point Value	do2	Digital Output 2
PID O/P	Output of the PID Algorithm		
OP1	Controller Output 1 (heat)		
OP2	Controller Output 2 (cool)		
I/P1	Analog Input 1		
I/P2	Analog Input 2		
I/P3	Analog Input 3		

**Table 1.1 Glossary of Abbreviations**



### 2.1 Introduction

The Operator level (Level 1) is the normal day-to-day mode of the COMMANDER 500. This section describes the operator facilities available on each frame depending on the control template and output type selected.

The template types detailed in this section are:

- Single loop controller
- Auto/Manual station
- Analog backup station
- Indicator/manual loader station

**Note.** Only the frames relevant to the selected template are displayed – see Section 4.

In addition, frames used to view the Control Efficiency Monitor and operate motorized valve and heat/cool output types are also described.

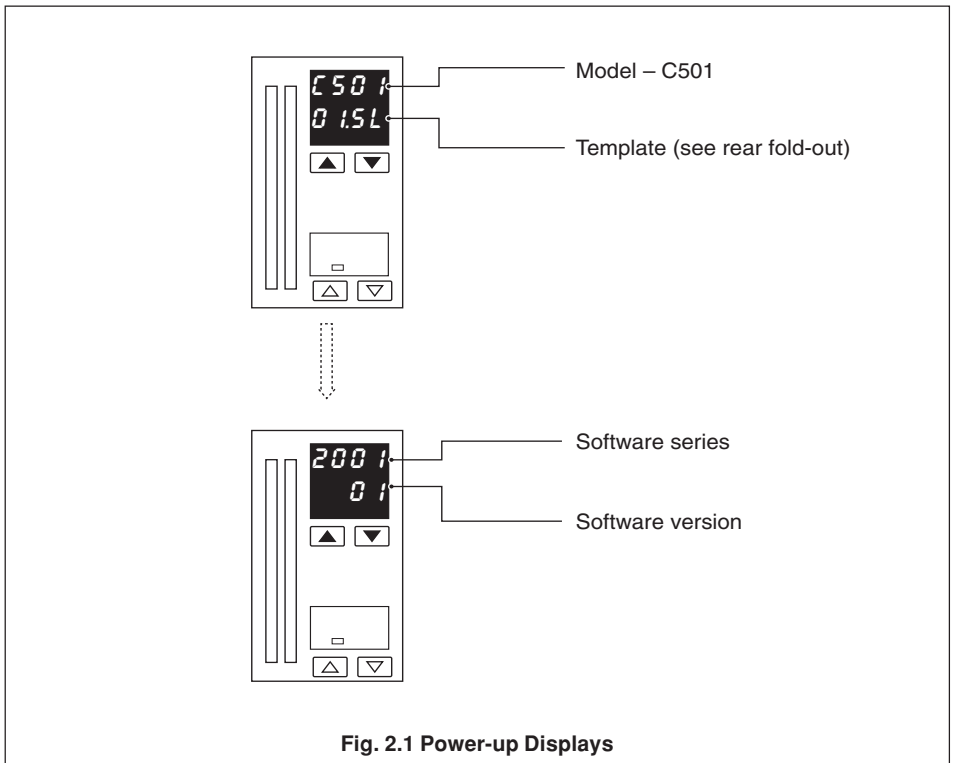

**Fig. 2.1 Power-up Displays**



## 2.2 Single Loop Controller (Templates 1 and 2)

The single loop controller is a basic feedback control system using three-term PID or on/off control with either a local set point (template 1) or remote set point (template 2).

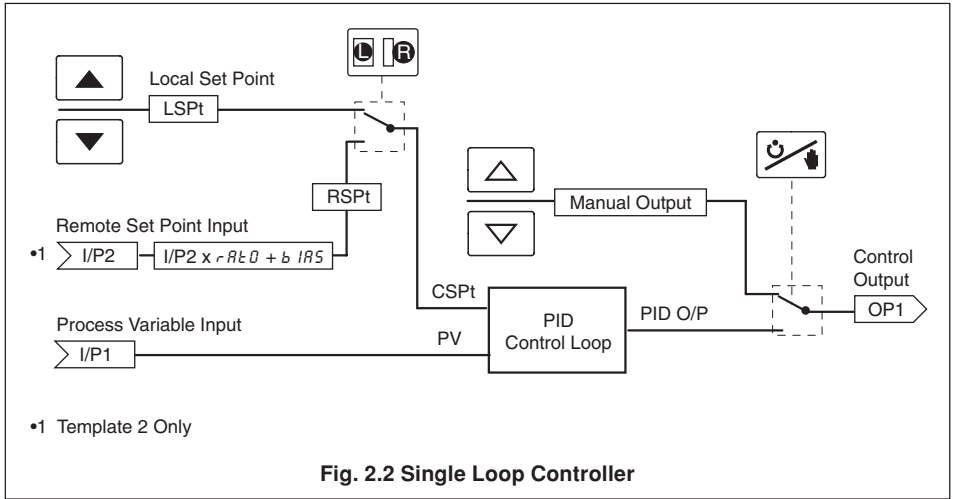
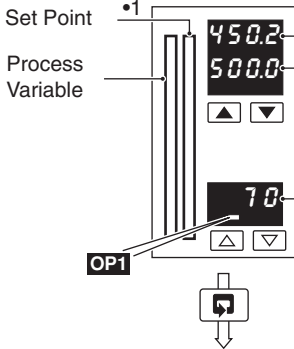

Fig. 2.2 Single Loop Controller





## ...2.2 Single Loop Controller (Templates 1 and 2)



**Process Variable**

**Control Set Point**

['SPLO' to 'SPHI' – see Section 4.5]  
Adjustable in Local Control Only

**Control Output**

[0 to 100% (digital/relay outputs),  
–10 to 110% (analog outputs)]

Adjustable in manual mode only. With on/off control selected, 0% = control output off, 100% = control output on. In manual mode, intermediate values can be selected. These use 'time proportioning' with a 60s cycle time, e.g. 25% = 15s on, 45s off.

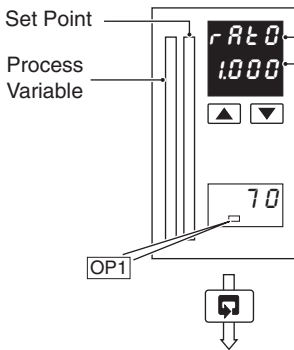

**Remote Set Point Ratio**

[0.001 to 9.999]

Remote set point value =  
(ratio x remote set point input) + bias

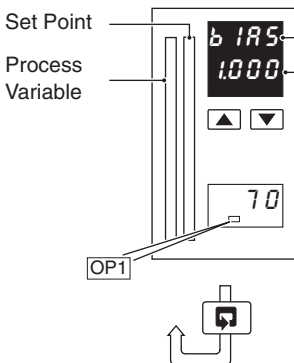

**Remote Set Point Bias**

[In engineering units]

Return to top of page

- 1 With the Ramping Set Point function enabled (see Section 3.3, Set Points/ Ramp Rate), the bargraph shows the actual (ramping) set point value and the digital display shows the target set point value.
- 2 Only displayed if template 2 selected and Ratio Display is enabled – see Section 4.2, Basic Configuration and Section 4.7, Operator Configuration.
- 3 Only displayed if template 2 selected and Bias Display is enabled – see Section 4.2, Basic Configuration and Section 4.7, Operator Configuration.



### 2.3 Auto/Manual Station (Templates 3 and 4)

**Note.** Refer also to Appendix A2.1 – Series and Parallel Operation.

The auto/manual station provides a backup for a master controller. In normal operation the COMMANDER 500's analog output follows the master controller's output value. A fault in the master system can be identified either by detecting a low signal on the master output (template 3) or via a digital signal (template 4). When a fault is detected the COMMANDER 500 goes into manual mode with its output either set to the last valid master output value or to a configured output value – see Section 4.6, Control Configuration/ Configured Output 1. When the master output is restored or the digital input returns to its inactive state, the COMMANDER 500 switches back to auto mode.

**Note.** The Alarm A1 Trip value must be set when using template 3.

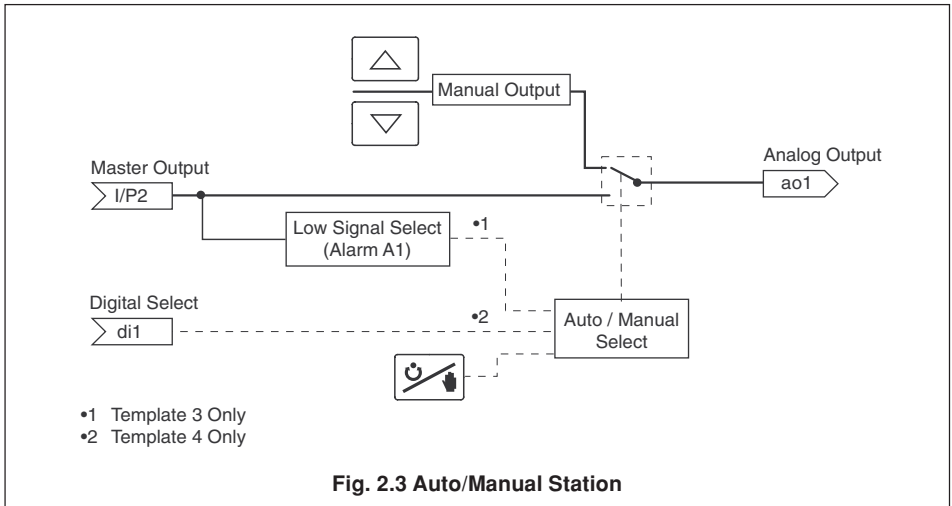



### ...2.3 Auto/Manual Station (Templates 3 and 4)

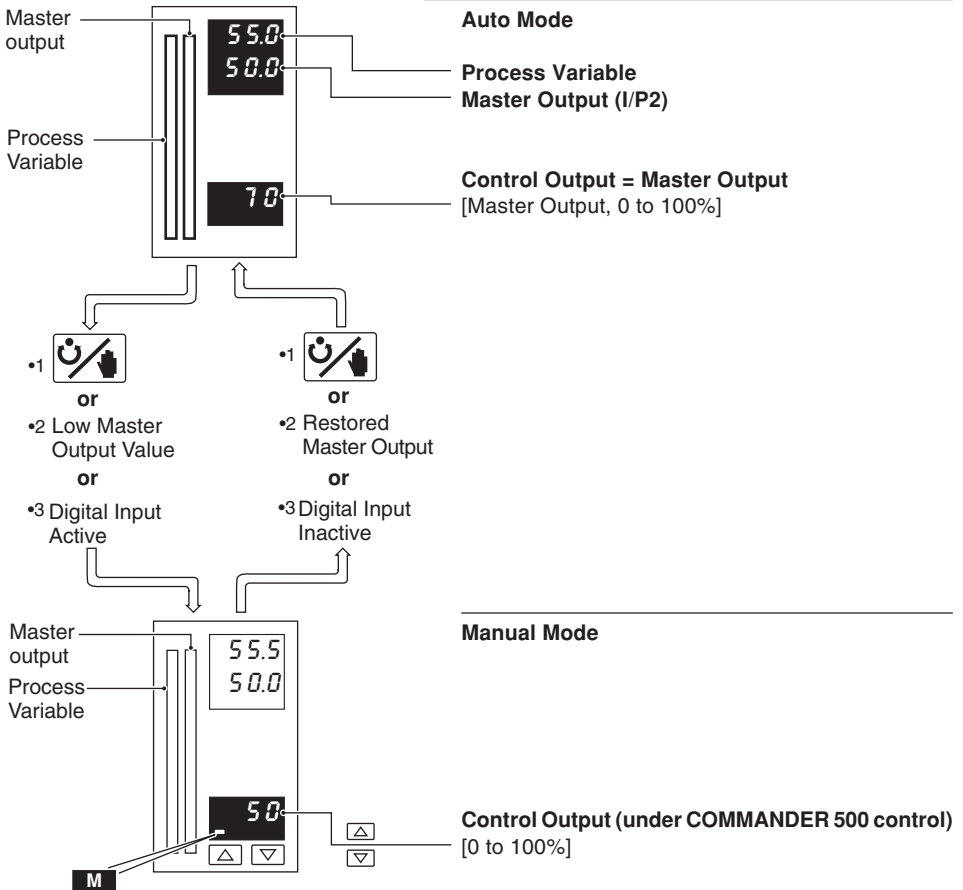

- 1 In template 4 the Auto/Manual switch is overridden by the digital input signal.
- 2 Template 3 only – see Section 4.2, Basic Configuration/ Template Application.
- 3 Template 4 only – see Section 4.2, Basic Configuration/ Template Application.



### 2.4 Analog Backup (Templates 5 and 6)

**Note.** Refer also to Appendix A2.1 – Series and Parallel Operation.

The analog backup station provides a backup for a master controller. In normal operation (remote control mode selected) the COMMANDER 500's current output follows the master controller's output value. A fault in the master system can be identified either by detecting a low signal on the master output (template 5) or via a digital signal (template 6). When a fault is detected the COMMANDER 500 switches into local control mode and the process is controlled by the PID output of the COMMANDER 500. The COMMANDER 500 PID algorithm tracks the master output value continuously in order to ensure bumpless transfer from remote to local mode operation. When the master output is restored or the digital input returns to its inactive state, the COMMANDER 500 switches back to remote control mode.

**Note.** The Alarm A1 Trip value must be set when using template 5.

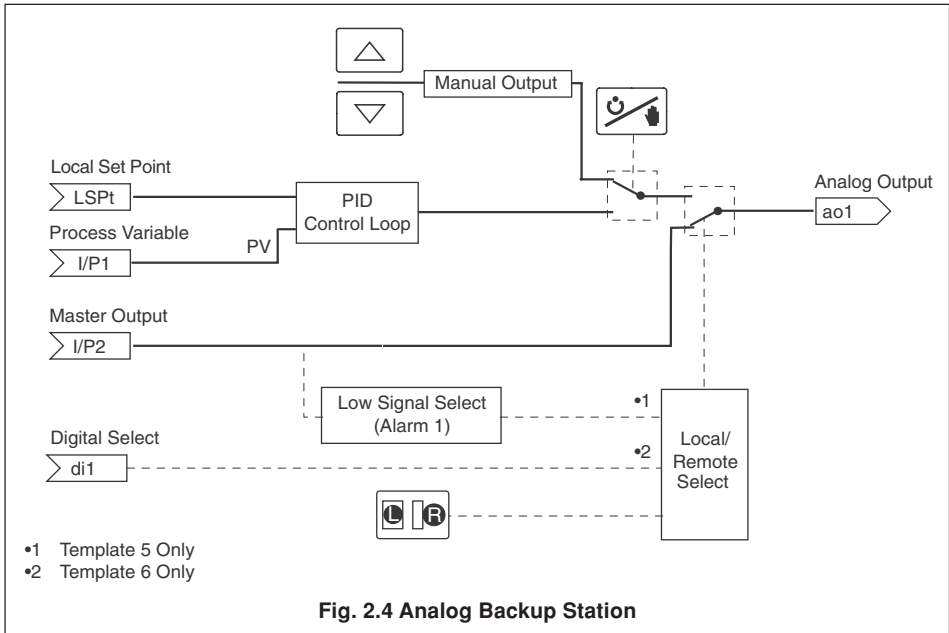



## ...2.4 Analog Backup (Templates 5 and 6)

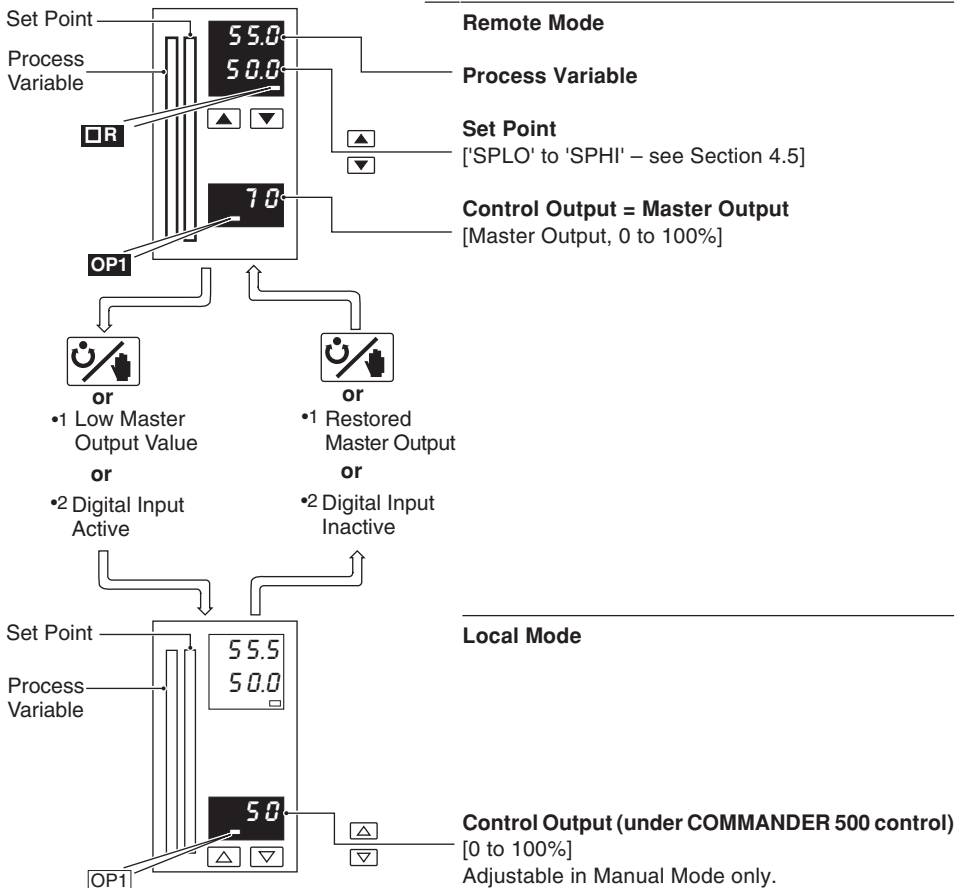

- 1 Template 5 only – see Section 4.2, Basic Configuration/ Template Application.
- 2 Template 6 only – see Section 4.2, Basic Configuration/ Template Application.



## 2.5 Indicator/Manual Loader Station (Templates 7 and 8)

One or two process variables can be displayed on the digital and bargraph displays. If the control output is assigned to an analog output the lower display indicates its value which can be adjusted by the user.

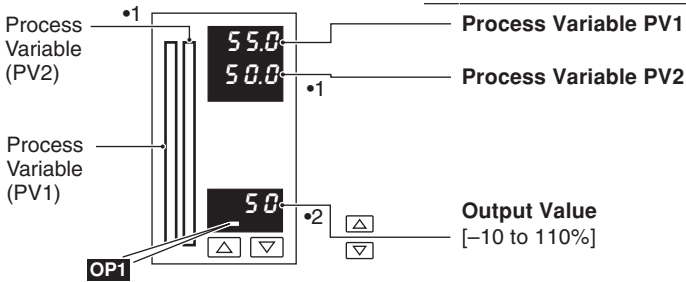

- 1 Only displayed if template 8 selected – see Section 4.2, Basic Configuration/Template Application.
- 2 Only displayed if control output type is 'analog' (output is assigned to Analog Output 1).



## 2.6 Heat/Cool Output Types

### 2.6.1 Reverse (Heat)/Direct (Cool) or Direct (Heat)/Reverse (Cool)

The active output, either OP1 (Heat) or OP2 (Cool) is displayed and may be adjusted in manual mode. The OP1 and OP2 I.e.d.s indicate which output is changing.

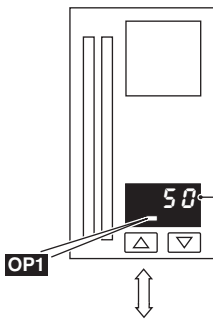
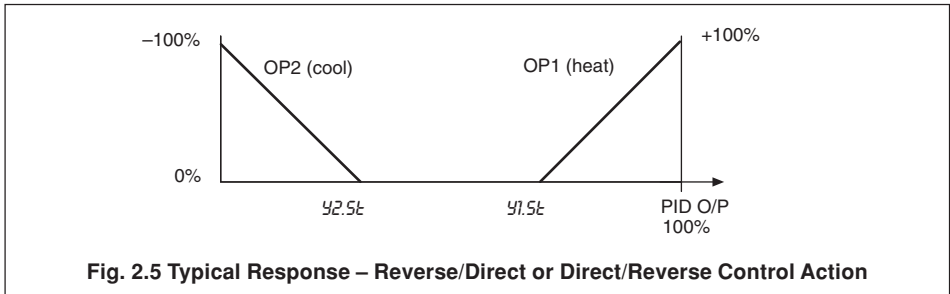

#### Output Positive (Heat Output Active)

##### Heat Output

[0 to 100% (0 to 110% in manual mode with analog outputs)]

Adjustable in manual mode only.

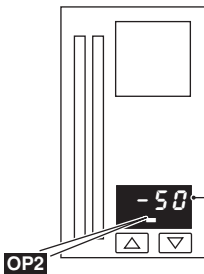

#### Output Negative (Cool Output Active)

##### Cool Output

[-100 to 0% (-110 to 0% in manual mode with analog outputs)]

Adjustable in manual mode only.



### 2.6.2 Reverse (Heat)/Reverse (Cool) or Direct (Heat)/Direct (Cool)

It is not possible to view or adjust the heat/cool outputs directly. The PID output (0 to 100%), used to calculate the heat (OP1) and cool (OP2) outputs, is displayed and may be adjusted in manual mode. The OP1 and OP2 I.e.d.s indicate which output is changing.

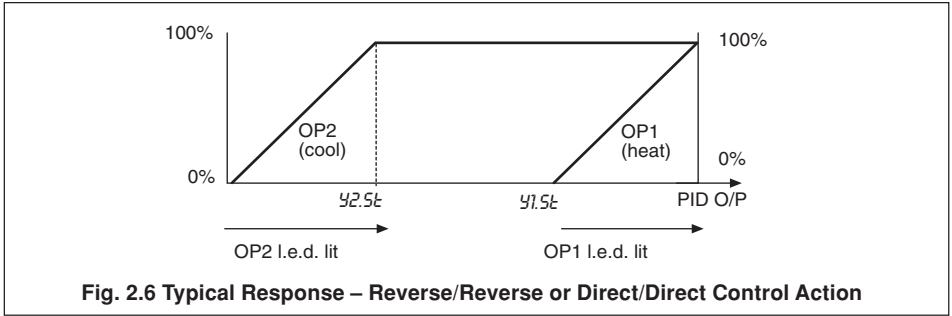
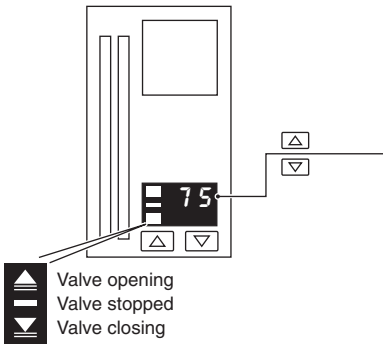

Fig. 2.6 Typical Response – Reverse/Reverse or Direct/Direct Control Action

## 2.7 Motorized Valve Output Types

### 2.7.1 Motorized Valve with Feedback



#### Valve Position Display

[0 to 100% of travel]

**Note.** In manual mode, the and keys can be used to drive the valve open and valve close relays directly.

### 2.7.2 Motorized Valve without Feedback (Boundless)

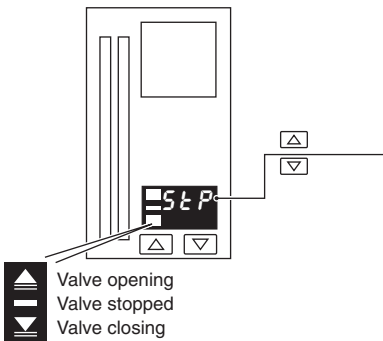

#### Valve State Display

<i>OPN</i>	Valve opening
<i>5 t P</i>	Valve stopped
<i>CLS</i>	Valve closing

**Note.** In manual mode, the and keys can be used to drive the valve open and valve close relays directly.





## 2.8 Auto-tune

**Note.** Auto-tune is not available for Auto/Manual Station, Indicator or Ratio Station templates, or when boundless or heat/cool control types are selected.

### Information.

- Auto-tune optimizes process control by manipulating the COMMANDER 500 output and then monitoring the process response.
- At the end of an auto-tune, the control parameters are updated automatically.
- Before starting auto-tune, the process variable must be stable.
- The COMMANDER 500 monitors the noise level of the process variable for 30 seconds and if it is greater than 2% of the engineering range the auto-tune is aborted.
- The COMMANDER 500 selects either 'start-up' or 'at set point' tuning automatically, depending upon the level of the process variable relative to the control set point.

### 2.8.1 Start-up Auto-tune

If the process variable is more than  $\pm 10\%$  from the set point, 'start-up' tuning is carried out.

- 'Start-up' tuning – steps the output to drive the process towards the set point. The process response to this step change is monitored and PID parameters are calculated.
- The output step applied = % deviation from the set point  $\times 1.5$ .
- If no errors exist, the COMMANDER 500 enters auto mode and begins to control the process using the new PID parameters.
- If an error occurs during the auto-tune, the COMMANDER 500 reverts to manual mode with the control output set to the default output value. An error message is displayed in the operator level – see Table 2.1.

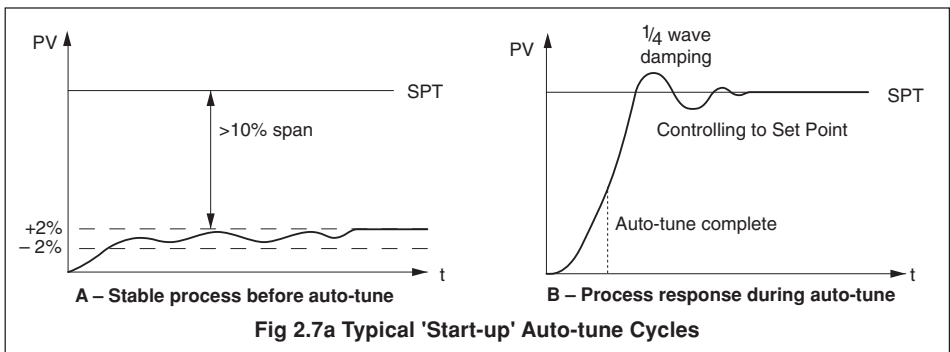

Error	Description	Error	Description
1	PV failed during auto-tune	7	A resultant P, I or D value was calculated out of range
2	Auto-tune has timed out during an auto-tune step	8	PV limit exceeded ('Start up' auto-tune)
3	Process too noisy to auto-tune	9	Controller put into configuration mode
4	Process too fast to auto-tune	10	Auto-tune terminated by user
5	Process too slow to auto-tune (max 12 hours between half-cycles).	11	PV is changing in the wrong direction during step test
6	PV deviated from set point by $>25\%$ eng. span during frequency response test		

**Table 2.1 Auto-tune Error Codes**



### 2.8.2 'At Set Point' Auto-tune

If the process variable is within 10% of the set point, 'at set point' tuning is carried out.

- 'At set point' tuning – manipulates the control output to produce a controlled oscillation of the process.
- A step change of  $\pm 10\%$  of the starting output value is applied initially. This is adjusted to give an amplitude of oscillation 3 times the noise level.
- Once the amplitude and period of oscillation are consistent (minimum 2 cycles, maximum 4 cycles) PID parameters are calculated.
- If no errors exist the controller enters auto mode and begins to control the process using the new PID parameters.
- If an error occurs during the auto-tune, the controller reverts to manual mode with the control output set to the default output value. An error message is displayed in the operator level – see Table 2.1.

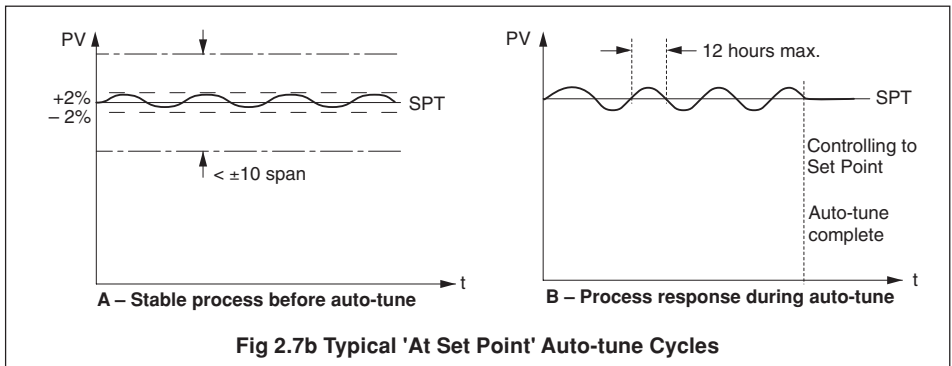

**Note.** The time taken to complete auto-tune depends upon the system response time.

**Note. Time Proportioning** – the cycle time must be set prior to running an auto-tune. The cycle time is not changed by the auto-tune.



### 2.8.3 Auto-tune

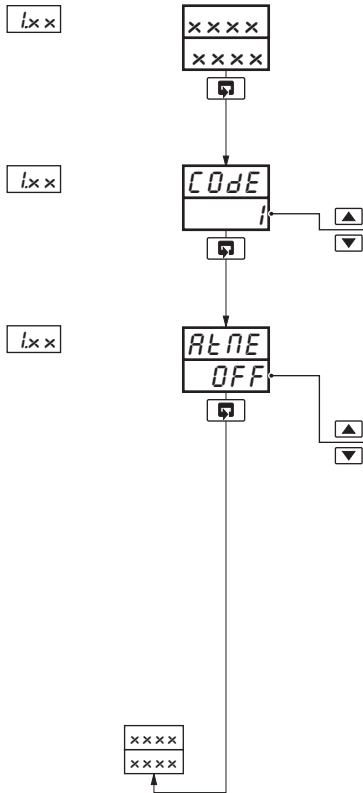

#### Accessing the Auto-tune Facility

From any operating frame, press and hold the `↵` key until the 'COdE' frame is displayed.

#### Auto-tune Enable

Select the type of auto-tune required.

#### Single Loop Templates

- `OFF` – Off
- `R` – Type A
- `b` – Type B

Auto-tune is started automatically when the `↵` key is pressed.

Auto-tune can be stopped at any time by pressing the `⏏` key.

**Note. P + I control only** – set the derivative term to 'OFF' in the Tuning Level – see Section 3.2.

Return to the Operating Level.

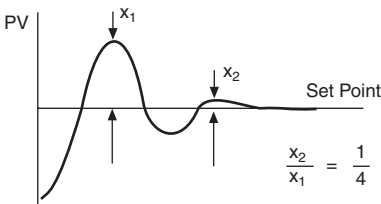

Type A – 1/4 wave damping



Type B – Minimum Overshoot

Fig. 2.8 Autotune Types



## 2.9 Control Efficiency Monitor

The Control Efficiency Monitor can be used either to compare the relative performance with different tuning parameters, or when fine tuning the PID settings, to give optimum control.

When the set point is changed, auto mode is selected or following a power failure, input failure or a large load disturbance, the control monitor performs a series of measurements to indicate the effectiveness of the current control parameters.

General guidelines are shown in Table 2.2.





Parameter	Ideal Setting	Actual Setting	Effect on Response	Action
Rate of Approach	Fast	Too slow		<ul style="list-style-type: none"> <li>• Decrease proportional band</li> <li>• Decrease integral time</li> <li>• Increase derivative time</li> </ul>
Overshoot	Small	Too large		<ul style="list-style-type: none"> <li>• Increase proportional band</li> <li>• Increase derivative time</li> </ul>
Decay Ratio	Small	Too large (Oscillatory)		<ul style="list-style-type: none"> <li>• Increase proportional band</li> <li>• Increase integral time</li> </ul>
Settling Time	Short	Too long		<ul style="list-style-type: none"> <li>• Increase proportional band</li> <li>• Decrease integral time</li> </ul>
Error Integral	Small	Too large	 	<p>If large overshoot and oscillatory then:</p> <ul style="list-style-type: none"> <li>• Increase proportional band</li> <li>• Increase integral time</li> <li>• Increase derivative time</li> </ul> <p>If slow approach and overdamped then:</p> <ul style="list-style-type: none"> <li>• Decrease proportional band</li> <li>• Decrease integral time</li> </ul>

Table 2.2 Control Efficiency Monitor Settings



## ...2.9 Control Efficiency Monitor

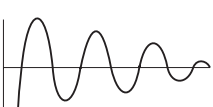
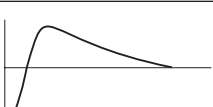
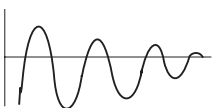

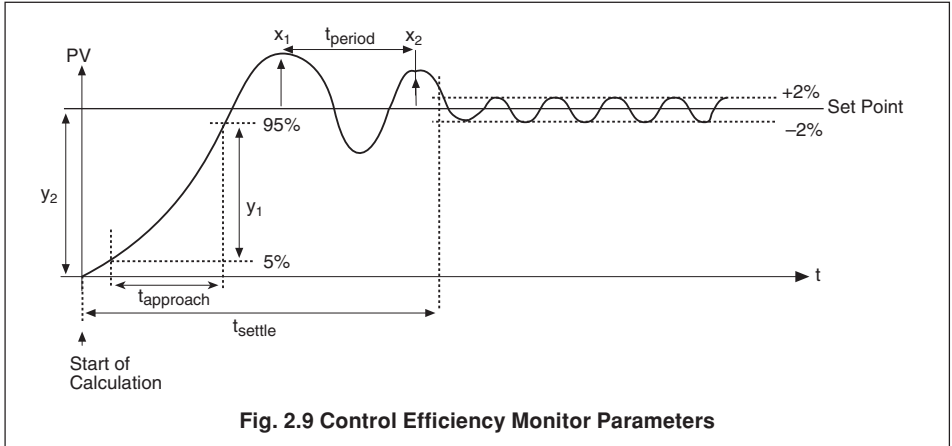
### 2.9.1 Manual Tuning

The Control Efficiency Monitor may be used for manually tuning the PID parameters. The following method describes how to tune the controller for  $1/4$  wave damping:

- a) Set the integral and derivative action times to OFF.
- b) Set the proportional band (PB) to a low setting.
- c) Apply a small set point change.
- d) Use the Control Efficiency Monitor to note the decay ratio.
- e) If the decay ratio  $> 0.25$ , increase the Proportional Band until decay ratio = 0.25  
If the decay ratio  $< 0.25$ , decrease the Proportional Band until decay ratio = 0.25
- f) Leave the proportional band at the setting which gives 0.25 decay ratio and, using the Control Efficiency Monitor, note the period between peaks.
- g) Calculate and set the following parameters:  
Integral action time = Period/1.5  
Derivative action time = Period/6

**Note.** The manual tuning facility must not be used with boundless motorized valve control, as an Integral Action Time is required for these applications.



## 2.9.2 Using the Control Efficiency Monitor

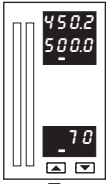

Press and hold the lower  $\triangle$  and  $\nabla$  keys for 2 seconds.

### Note.

If the front panel keys are not operated for 60 seconds whilst any Control Efficiency Monitor frame is being displayed, the instrument reverts to the first operating frame.

### Rate of Approach to Set Point

The rate of change of the process variable between 5 and 95% of the step change ( $Y_2$ ), measured in engineering units per minute.

$$\text{Rate of approach} = \frac{Y_1}{t_{\text{approach}}}$$

### Overshoot

The maximum error, expressed as a percentage of the set point.

$$\text{Overshoot} = \frac{X_1}{\text{Set Point}} \times 100$$

### Decay Ratio

The ratio of the amplitude of the first and second overshoots.

$$\text{Ratio} = \frac{X_2}{X_1}$$

### Period

The time (in seconds) between the first two peaks ( $t_{\text{period}}$ ).

### Settling Time

The time taken (in minutes) for the process variable to settle within  $\pm 2\%$  of the set point value ( $t_{\text{settle}}$ ).

### Error Integral

The integral of the error value until the process variable settles to within  $\pm 2\%$  of the set point value in 'engineering-unit hours'.

$$\text{Error integral} = \int_0^{t_{\text{settle}}} |PV - SP| dt$$

Return to the first operating frame.

### 3 SET UP MODE

#### 3.1 Introduction

To access the Set Up mode (Levels 2 to 5) the correct password must be entered in the security code frame.

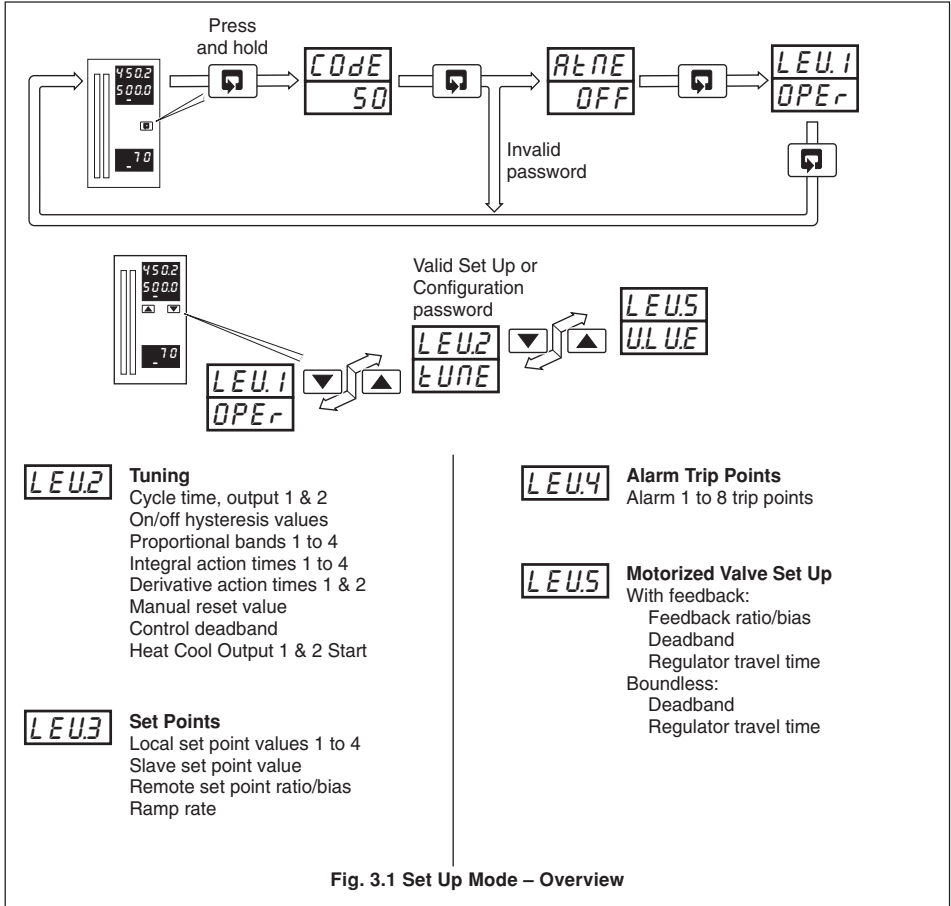

Fig. 3.1 Set Up Mode – Overview

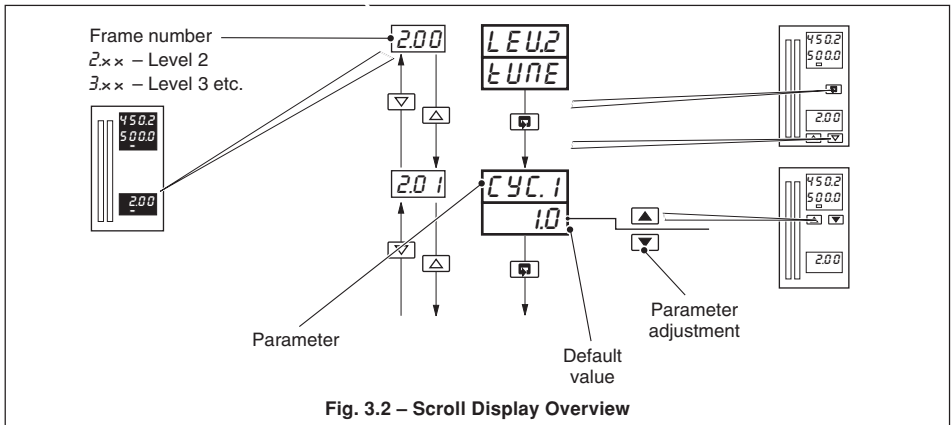
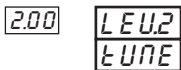

Fig. 3.2 – Scroll Display Overview

3.2 Level 2 – Tune

2.00...2.04

**Note.** Level 2 is not applicable if an Auto/Manual Station or Indicator template is selected.



Level 2 – Tune

**Note.** To select this frame from anywhere in this page, press and hold the key for a few seconds.



Cycle Time Output 1

[1.0 to 300.0 seconds for time proportioning or 'OnOF' for on/off control]

**Note.** On/off Control is not available on output 1 with heat/cool control.

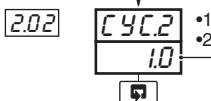

Cycle Time Output 2 (Cool)

[1.0 to 300.0 seconds for time proportioning or 'OnOF' for on/off control]

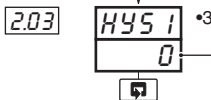

Output 1 On/Off Hysteresis Value

[In engineering units]

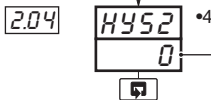
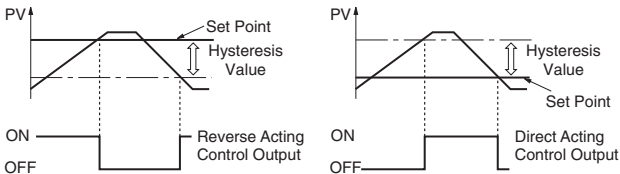

Output 2 On/Off Hysteresis Value

[0% to (Y1.St – Y2.St)%] – see parameters 2.22 and 2.23

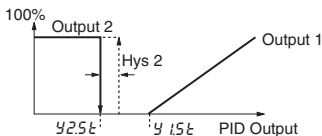

Continued on next page

- 1 Only displayed if Relay or Digital output type is selected – see Section 4.2, Basic Configuration/ Output Type.
- 2 Only displayed if Heat/Cool output type is selected.
- 3 Only if On/Off control is selected – see parameters 2.01 and 2.02 above.
- 4 Only displayed if Heat/Cool output type is select and the 'CYC.2' parameter is set to 'OnOF'.



## ...3.2 Level 2 – Tune

2.05...2.13

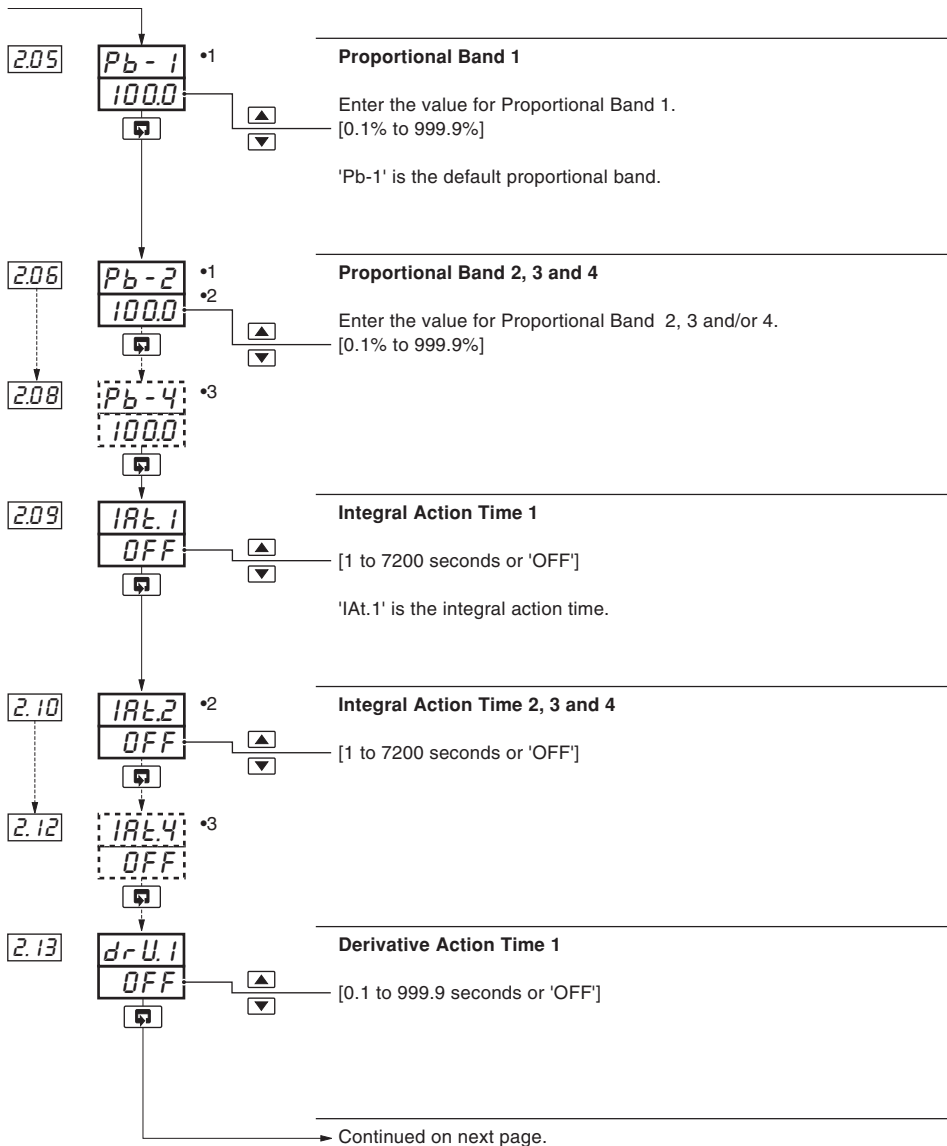

- 1 Heat/cool outputs use a common proportional band. The default is 'Pb-1'.
- 2 Only displayed if a tune parameter source is selected – see Section 4.2, Basic Configuration/ Template Application and Section 4.6, Control Configuration/ Tune Parameter Source.
- 3 Only displayed if a tune parameter source is selected – see section 4.6, Control Configuration/ Tune Parameter Source.

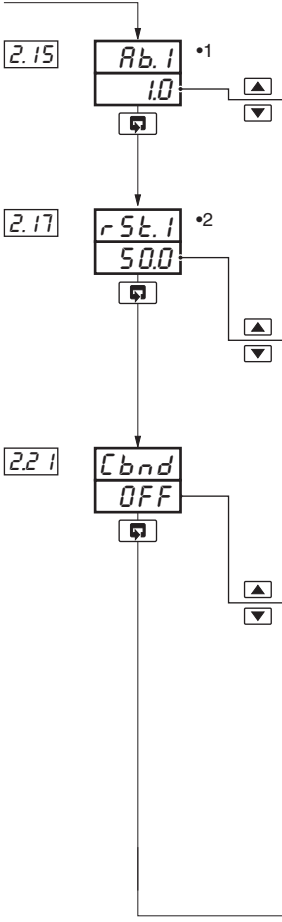

**Approach Band 1**

[0.1 to 3.0 proportional bands]

This parameter limits when derivative action time 1 is applied. When the process variable is outside the approach band, derivative action is not applied.

**Manual Reset Value 1**

The value applied to bring the master control output to the zero error point under normal load conditions (integral action disabled) or the offset applied to the control output (integral action enabled).

[0.0 to 100%]

**Note.** Manual reset is applied whether or not an integral action time is selected.

**Control Deadband**

When the process variable is in the deadband, changes to the control output due to proportional and integral action are suppressed.

[In engineering units or 'OFF']

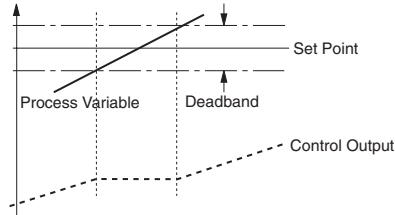

Continued on next page.

- 1 Not displayed if the associated derivative action time is set to OFF.
- 2 If manual control is selected and no integral action time is set, the manual reset value is calculated automatically to give bumpless transfer into auto control.



...3.2 Level 2 – Tune

2.22...2.23

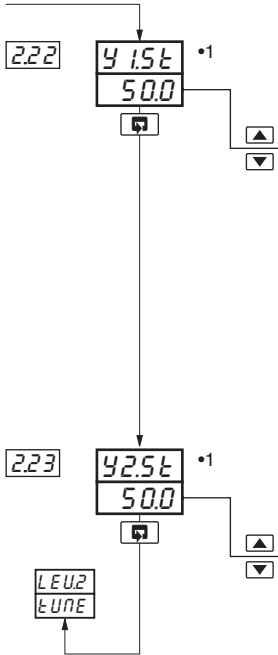

**Heat/Cool Output 1 Start**

This parameter defines the PID output value above which Output 1 (heat) becomes active.

[0.0 to 100.0%]

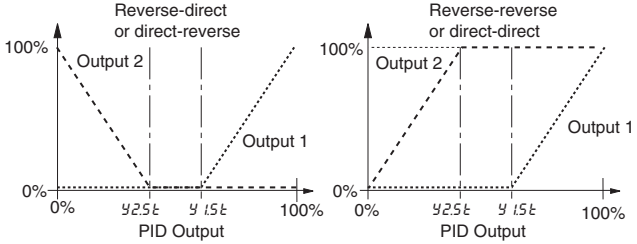

**Heat/Cool Output 2 Start**

This parameter defines the PID output value below which Output 2 (cool) becomes active.

[0.0 to ≤ Y1st %] – see Heat/Cool Output 1

Return to top of page

•1 Only displayed if a Heat/Cool output type is selected – see Section 4.2, Basic Configuration/ Output Type.



### 3.3 Level 3 – Set Points

3.00...3.07

**Note.** Level 3 is not applicable if Auto/Manual Station or Indicator templates are selected.

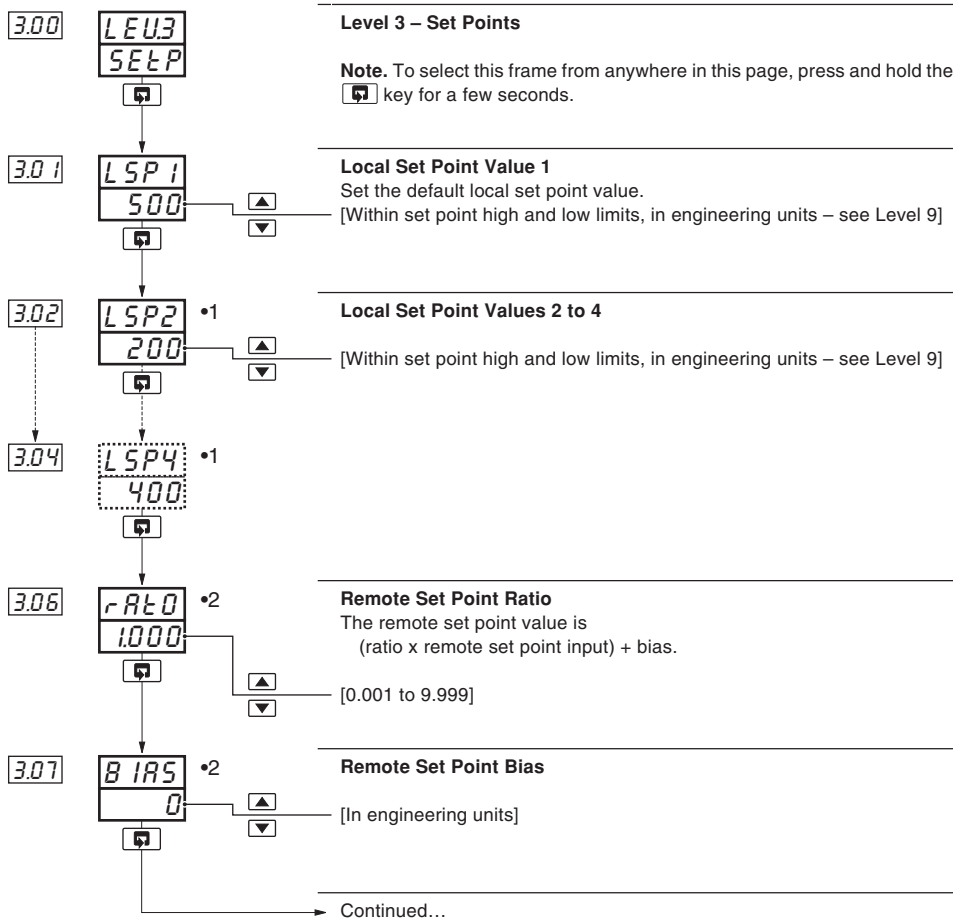

•1 Displayed only if a local set point source is selected – see Section 4.5/ Set Point Configuration/ Local/Remote Set Point Source.

•2 Displayed only for templates with a remote set point.

## ...3.3 Level 3 – Set Points

3.10

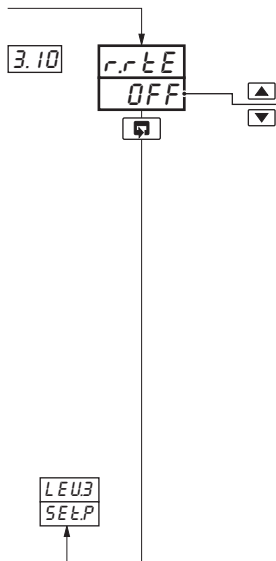
**Ramp Rate**

[1 to 9999 engineering units per hour, or OFF]

The Ramping Set Point facility can be used to prevent a large disturbance to the control output when the set point value is changed. The rate set applies to both the local and the remote set points.

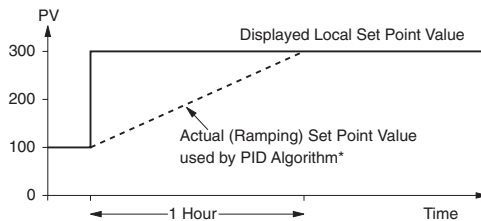

\* e.g. Ramp Rate = 200 Increments/Hour

Return to top of page.



### 3.4 Level 4 – Alarm Trip Points

4.00...4.08

**Note.** Level 4 is not applicable if all alarm types are set to 'None' – see Section 4.4, Alarms/ Alarm Type.

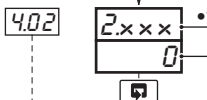
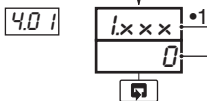
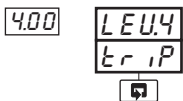

#### Level 4 – Alarm Trip Points

**Note.** To select this frame from anywhere in this page, press and hold the key for a few seconds.

#### Alarm 1 Trip

##### Alarm Number and Type

Display	Description	Display	Description
<i>none</i>	None	<i>LP3</i>	Low Process I/P3
<i>HPU</i>	High Process, PV	<i>HO</i>	High Output •2
<i>LPU</i>	Low Process, PV	<i>LO</i>	Low Output •2
<i>HL P</i>	High Latch, PV	<i>Hb 1</i>	Maths Block 1 High
<i>LL P</i>	Low Latch, PV	<i>Lb 1</i>	Maths Block 1 Low
<i>Hd</i>	High Deviation	<i>Hb 2</i>	Maths Block 2 High
<i>Ld</i>	Low Deviation	<i>Lb 2</i>	Maths Block 2 Low
<i>HP 1</i>	High Process I/P1	<i>Hb 3</i>	Maths Block 3 High
<i>LP 1</i>	Low Process I/P1	<i>Lb 3</i>	Maths Block 3 Low
<i>HP 2</i>	High Process I/P2	<i>Hb 4</i>	Maths Block 4 High
<i>LP 2</i>	Low Process I/P2	<i>Lb 4</i>	Maths Block 4 Low
<i>HP 3</i>	High Process I/P3		

##### Trip Value

[In engineering units]

**Note.** When an auto/manual station template or analog backup template is selected, Alarm 1 is set automatically as a low process alarm on Analog Input 2.

#### Alarm 2 to Alarm 8 Trip

##### Alarm Number and Type

See Alarm 1.

##### Trip Value

[In engineering units]

Return to top of page.

- 1 Not displayed if alarm type set to 'None' – see Section 4.4, Alarms/ Alarm Type.
- 2 Applies to PID output with single or heat/cool outputs.



### 3.5 Level 5 – Valve Setup

5.00...5.04

**Note.** Level 5 is applicable only for a motorized valve output type – see Section 4.2, Basic Configuration/ Output Type.

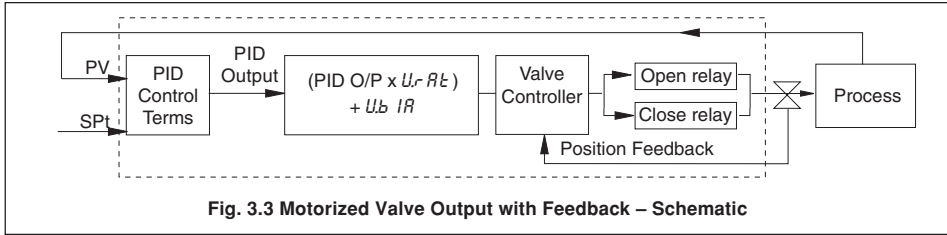
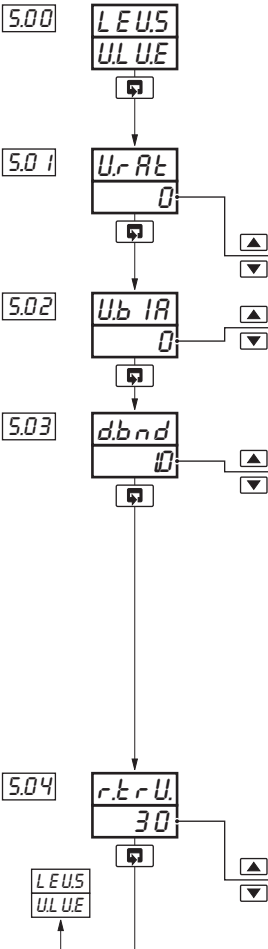

Fig. 3.3 Motorized Valve Output with Feedback – Schematic

#### 3.5.1 Valve Setup (Feedback Types)



#### Level 5 – Valve Setup

**Note.** To select this frame from anywhere in this page, press and hold the key for a few seconds.

#### Motorized Valve Ratio and Bias

Desired valve position = (Ratio x PID output) + Bias

#### Motorized Valve Ratio

[0.01 to 10.00]

#### Motorized Valve Bias

[-100.0 to 100.0%]

#### Motorized Valve Deadband

[0.0 to 100% of the position feedback span]

Position %

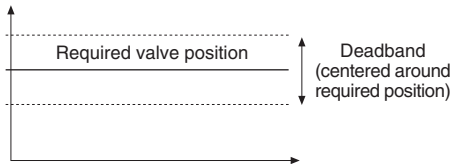

**Example.** If the valve is set to be driven to the 50% open position and the deadband is set to 4%, the motor stops driving when the position feedback is 48%. The deadband is between 48% and 52%.

#### Regulator Travel Time

The time entered is compared with the actual travel time. If the valve is sticking an error message is generated.

[0 to 5000 seconds, 0 = no check]

Return to top of page.



### 3.5.2 Valve Setup (Boundless Types) – Fig. 3.4

A 'boundless' process controller provides an output that is effectively the time derivative of the required regulator position, i.e. the COMMANDER 500 signals the regulator, not where to go to (position derivative), but in which direction to travel and how far to move, by a series of integral action pulses. Thus, the COMMANDER 500 does not need to know the absolute regulator position and is unaffected when regulator reaches the upper or lower limit, as determined by the regulator's limit switches (giving rise to the term 'boundless').

When a deviation from set point is introduced the regulator is driven, for a length of time equivalent to the proportional step. The regulator is then driven by integral action pulses until the deviation is within the deadband setting.

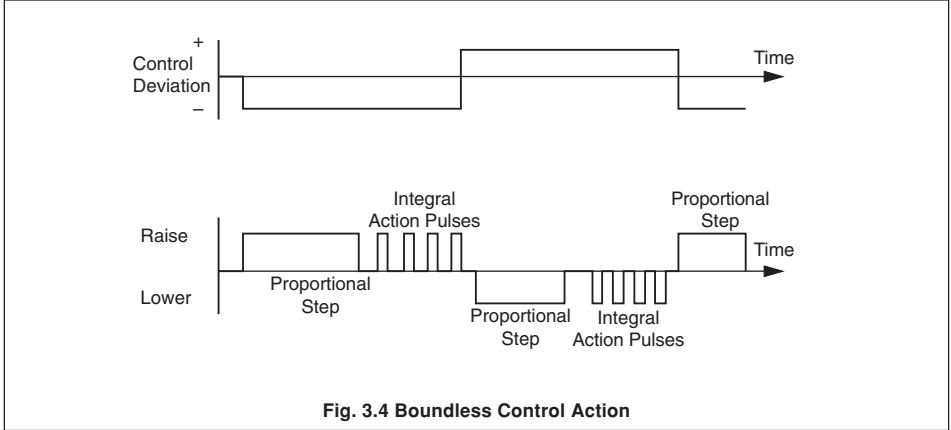

Fig. 3.4 Boundless Control Action

#### Calculation for Control Pulses (Boundless Control)

The following calculations are shown for guidance when setting deadband, proportional and integral values. They can be used to check the suitability of boundless control for a particular actuator/application.

Minimum 'ON' time of integral action pulses (for a fixed control deviation).

$$= \frac{\text{Travel Time} \times \text{Deadband \%}}{\% \text{ Proportional Band}} \text{ (in seconds)}$$

Minimum (approximate) time between integral action pulses (for a fixed control deviation)

$$= \frac{\text{Integral Action Time} \times \text{Deadband \%}}{2 \times \% \text{ Control Deviation}} \text{ (in seconds)}$$

Duration of the proportional step

$$= 2 \times \left[ \frac{\% \text{ Control Deviation}}{\% \text{ Proportional Band}} \right] \times \text{Travel Time in Seconds}$$

% Control Deviation

$$= \frac{\text{Set Point} - \text{Process Variable}}{\text{Eng Hi} - \text{Eng Lo}} \times 100\%$$

% Deadband

$$= \frac{\text{Deadband (eng units)}}{\text{Eng Hi} - \text{Eng Lo}} \times 100\%$$





## ...3.5.2 Valve Setup – Boundless

5.00...5.04

5.00

 LEUS  
 ULUE

## Level 5 – Valve Setup

**Note.** To select this frame from anywhere in this page, press and hold the key for a few seconds.

5.03

 dbnd  
 0

## Boundless Deadband

[In engineering units]

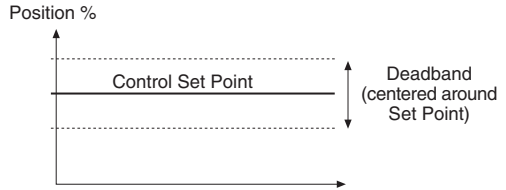

5.04

 r.t.r.U.  
 0

## Regulator Travel Time

The time taken for the regulator to travel from the fully open to the fully closed position.

[1 to 5000 seconds]

 LEUS  
 ULUE

Return to top of page.



# 4 CONFIGURATION MODE

## 4.1 Introduction

To access the Configuration mode (Levels 6 to E) the correct password must be entered in the security code frame.

**Note.** When in the configuration mode, alternate bargraph led's are illuminated. All relays and digital outputs are de-energized and all analog outputs revert to the set minimum current output.

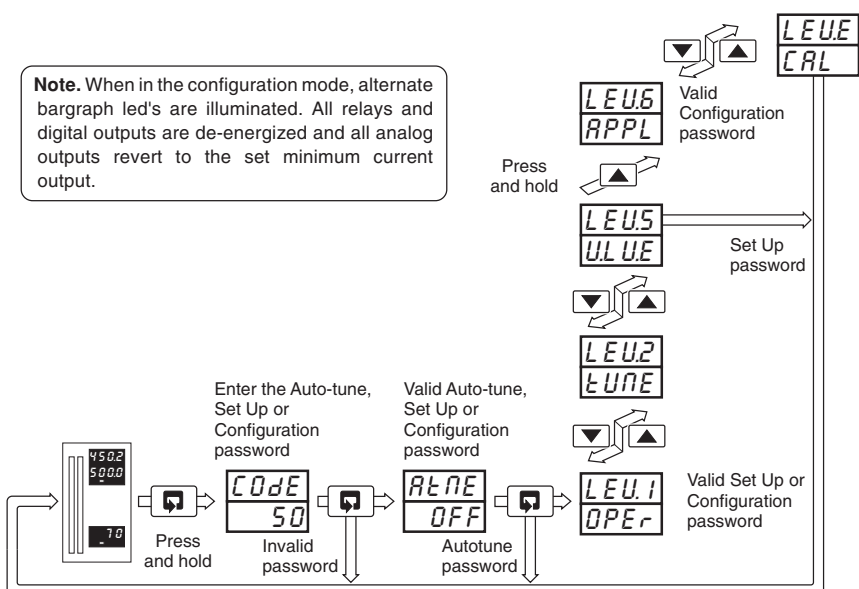

**LEU6**  
**APPL**

**Basic Configuration**  
Template application  
Output type  
Control action  
Mains rejection frequency

**LEU7**  
**INPE**

**Analog Inputs 1 to 3**  
Type  
Electrical range  
Decimal places  
Engineering range  
Broken sensor drive  
Input filter time constant

**LEU8**  
**ALR**

**Alarms 1 to 8**  
Type  
Trip level  
Hysteresis band

**LEU9**  
**SELP**

**Set Points**  
Tracking enable  
Set point limits  
Local set point sources 1 to 4  
Local/remote set point selection

**LEUA**  
**CNEL**

**Control Configuration**  
Power fail recovery action  
Output high/low limits  
Slew rate + disable  
Configured outputs 1 to 3  
Manual output selection sources  
Auto mode selection source  
Tune parameter sources 1 to 4

**LEUb**  
**OPER**

**Operator Configuration**  
Auto/manual key enables  
Local/remote key enables  
Alarm acknowledge key enable  
Operator set point adjust enable  
Operator ratio/bias enable  
Password settings  
Clock settings

**LEUC**  
**ASSN**

**Output Assignment**  
Outputs 1 and 2 type  
Digital output  
Assignment source  
Polarity  
Analog output  
Assignment source  
Electrical range  
Engineering range  
Relay outputs 1 to 4  
Assignment source  
Polarity

**LEUd**  
**SErL**

**Serial Communications**  
2-/4-wire connection  
2400/9600/19200 baud rate  
Parity  
MODBUS address

**LEUE**  
**CAL**

**Calibration**  
Offset/span adjustment  
Motorized valve feedback

Fig. 4.1 Configuration Mode – Summary



## 4.2 Level 6 – Basic Configuration

6.00...6.01

6.00

LEU6  
RPPL

6.01

LAPP  
1SL

## Level 6 – Basic Configuration

**Note.** To select this frame from anywhere in this page, press the key for a few seconds.

## Template Application

Templates are provided to make the basic configuration for a particular application as simple as possible. The appropriate template should be selected before any other parameters are configured. When a template is selected, the COMMANDER 500 assumes the preset form for that template (see Appendix A). The inputs and software blocks are automatically soft-wired to perform the selected function.

Select the Template required

Display	Template Description
01SL	Single loop with local set point only
02SL	Single loop with remote set point
03R_	Auto/Manual station with low signal selection
04R_	Auto/Manual station with digital selection
05Rb	Analog backup with low signal selection
06Rb	Analog backup with digital selection
07IN	Single indicator/manual loader
08IN	Double indicator/manual loader

**Note 1.** When a template is selected, the following default values apply: The 'Analog Input Type' of all inputs used by the template defaults to '2', i.e. 4 to 20mA; The engineering ranges of all inputs used default to '0.0 to 100.0'. All other inputs are set to 'OFF'.

**Note 2.** Templates customized using the PC Configurator are identified by the letter 'U' in the template code – i.e. template '01.SL' becomes '01.U'.

Continued...

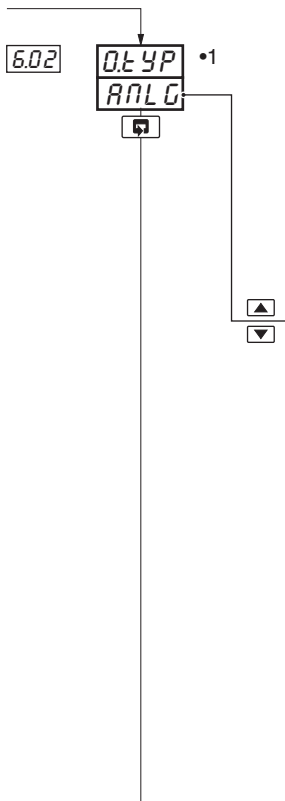

**Control Output Type**

The appropriate relays, digital outputs and analog outputs are assigned to the control output variables. The other hardware outputs are provisionally assigned to alarm and retransmission functions but these may be changed in the output assignment level – see Section 4.8.

Select the Output Type required – see also Fig. 4.2 overleaf and Rear Fold-out/ Table B.

Display	Output Type	
<i>none</i>	None	
<i>ANLG</i>	Analog output (Control output = ao1)	
<i>RLY</i>	Relay output (Control output = RLY1)	
<i>DIG</i>	Digital output (Control output = do1)	
<i>PFB</i>	Motorized valve with feedback (Open = RLY1, Close = RLY2)	•2 •3
<i>bnv</i>	Motorized valve without feedback (Open = RLY1, Close = RLY2)	
<i>HCrr</i>	Heat/cool with OP1 = relay, OP2 = relay	
<i>HCrd</i>	Heat/cool with OP1 = relay, OP2 = digital output	
<i>HCdr</i>	Heat/cool with OP1 = digital output, OP2 = relay	
<i>HCdd</i>	Heat/cool with OP1 = digital output, OP2 = digital output	•2
<i>HCRR</i>	Heat/cool with OP1 = analog, OP2 = relay	
<i>HCrd</i>	Heat/cool with OP1 = analog, OP2 = digital	•2
<i>HCRR</i>	Heat/cool with OP1 = analog, OP2 = analog	•2

Continued...

•1 Only output types 'none' and 'ANLG' are applicable to indicator templates. Only output type 'ANLG' is applicable to auto/manual station and analog backup templates.

•2 Only available with option board fitted.

•3 Analog Input 3 Type defaults to '11' – Resistance Feedback.



...4.2 Level 6 – Basic Configuration

Output Types:

<i>RnLG</i>
<i>rLY</i>
<i>dIG</i>

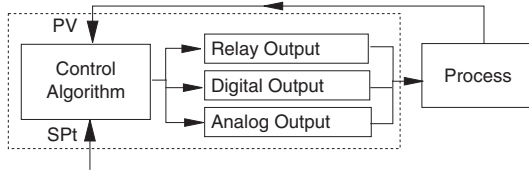

A – Single Output

Output Type:

<i>PFb</i>
------------

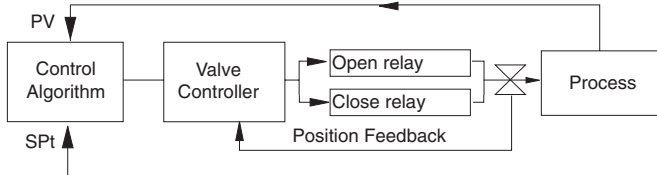

B – Motorized Valve Output with Feedback

Output Type:

<i>bnd</i>
------------

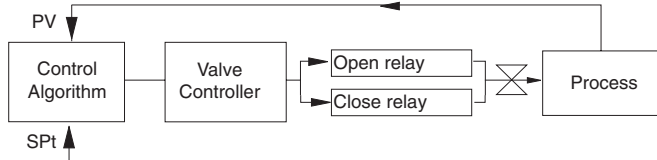

C – Motorized Valve Output without Feedback (Boundless)

Output Types:

<i>HCrr</i>
<i>HCrd</i>
<i>HCdr</i>
<i>HCdd</i>
<i>HCRR</i>
<i>HCrd</i>
<i>HCRR</i>

See Note

See Note

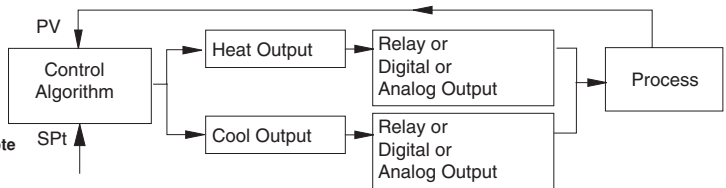

D – Heat/cool Output

Note. Only available if option board fitted.

Fig 4.2 Output Type Schematic Diagrams

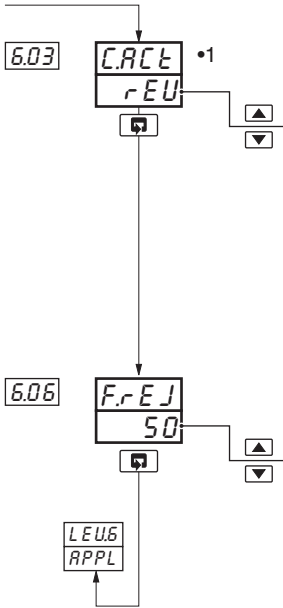

Control Action

	Single Loop	Output 1	
•2	r.EU.	Reverse	
•2	d.r	Direct	
	Heat/Cool	Output 1 (Heat)	Output 2 (Cool)
•3	r - d	Reverse	Direct
•3	r - r	Reverse	Reverse
•3	d - r	Direct	Reverse
•3	d - d	Direct	Direct

Mains Rejection Frequency

Used to filter mains frequency pick-up on external analog input wiring.

[50 or 60Hz]

Return to top of page.

- 1 Not displayed for auto/manual, indicator, ratio station or cascade templates.
- 2 Not displayed if Heat/Cool output types selected – see parameter 6.02.
- 3 Only displayed if Heat/Cool output types selected – see parameter 6.02.



## 4.3 Level 7 – Analog Inputs

7.00...7.03

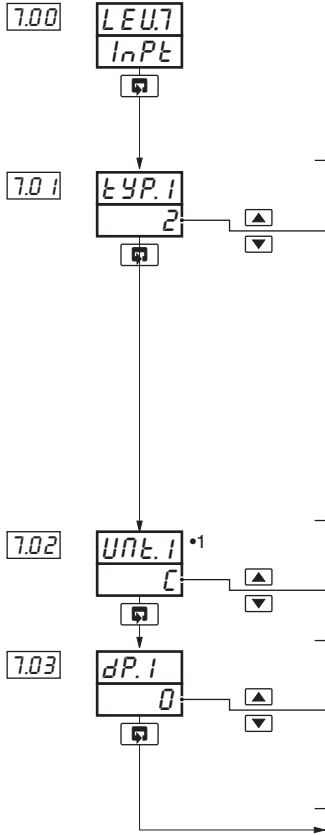

## Level 7 – Analog Inputs

**Note 1.** Refer also to the rear fold-out, Table A – Template Applications.

**Note 2.** To select this frame from anywhere in this page, press the  key for a few seconds.

## Analog Input 1 (I/P1) Type &amp; Electrical Range

Display	Description	Display	Description
<i>FFF</i>	Not Used	<i>P</i>	PT100 RTD
<i>b</i>	THC Type B	<i>1</i>	0 to 20mA
<i>E</i>	THC Type E	<i>2</i>	4 to 20mA
<i>J</i>	THC Type J	<i>3</i>	0 to 5V
<i>K</i>	THC Type K	<i>4</i>	1 to 5V
<i>L</i>	THC Type L	<i>5</i>	0 to 50mV
<i>N</i>	THC Type N	<i>7</i>	4 to 20mA square root linearizer
<i>r</i>	THC Type R	<i>8</i>	4 to 20mA power 3/2
<i>S</i>	THC Type S	<i>9</i>	4 to 20mA power 5/2
<i>t</i>	THC Type T	<i>U</i>	Custom

## Temperature Units (I/P1)

*C* – THC readings displayed in °C  
*F* – THC readings displayed in °F

## Decimal Places (Engineering Range, I/P1)

*0* XXXX  
*1* XXX.X  
*2* XX.XX  
*3* X.XXX

Continued...

•1 Only displayed if THC or RTD input types are selected



7.04

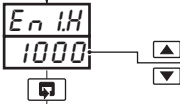

**Engineering High (I/P1)**

[-999 to 9999]

**Note.** This parameter defaults to the maximum allowed value when THC or RTD inputs are selected – see Table 4.1.

THC/RTD Type	°C			°F		
	Min.	Max.	Min. Span	Min.	Max.	Min. Span
Type B	-18	1800	710	0	3272	1278
Type E	-100	900	45	-148	1652	81
Type J	-100	900	50	-148	1652	90
Type K	-100	1300	65	-148	2372	117
Type L	-100	900	50	-148	1652	90
Type N	-200	1300	90	-328	2372	162
Type R & S	-18	1700	320	0	3092	576
Type T	-250	300	60	-418	572	108
Pt100	-200	600	25	-328	1112	45

**Table 4.1 Engineering Limits, THC & RTD Inputs**

7.05

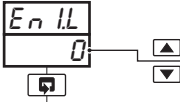

**Engineering Low (I/P1)**

[-999 to 9999]

**Note.** This parameter defaults to the minimum allowed value when THC or RTD inputs are selected – see Table 4.1.

7.06

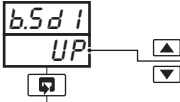

**Broken Sensor Drive (I/P1)**

- none* – No action. Actual input values remain valid.
- UP* – Input driven to the maximum upscale value (999)
- dN* – Input driven to the minimum downscale value (-999)

In the event of a fault being detected on the input, the input is driven in the direction selected.

7.07

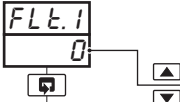

**Input Filter Time Constant (I/P1)**

The input values are averaged over the time set.

[0 to 60 seconds]

Continued...





... 4.3 Level 7 – Analog Inputs

7.08...7.14

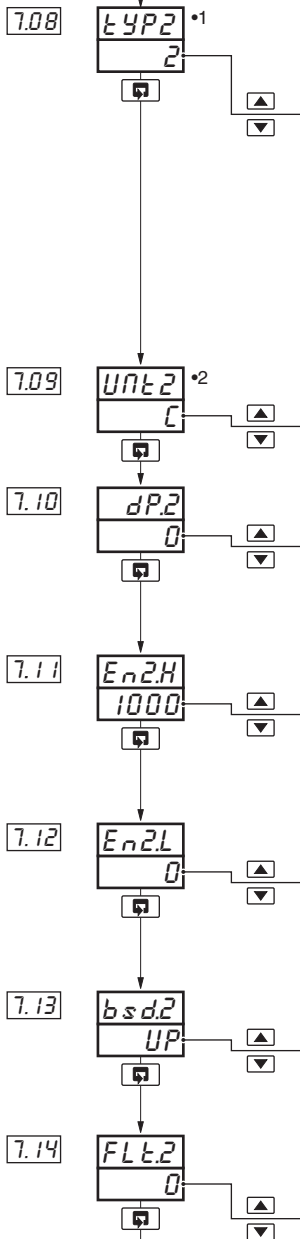

**Analog Input Type & Electrical Range (I/P2)**

**Note.** THC inputs can only be used on I/P2 if I/P1 is also set to THC.

Display	Description	Display	Description
OFF	Not Used	t	THC Type 1
b	THC Type B	i	0 to 20mA
E	THC Type E	2	4 to 20mA
J	THC Type J	6	0 to 50mV
K	THC Type K	7	4 to 20mA square root linearizer
L	THC Type L	8	4 to 20mA power 3/2
n	THC Type N	9	4 to 20mA power 5/2
r	THC Type R	U	Custom
S	THC Type S		

**Temperature Units (I/P2)**

C – THC readings displayed in °C  
 F – THC readings displayed in °F

**Decimal Places (Engineering Range, I/P2)**

0 XXXX  
 1 XXX.X  
 2 XX.XX  
 3 X.XXX

**Engineering High (I/P2)**

[–999 to 9999]

**Note.** This parameter defaults to the maximum allowed value when THC input type is selected – see Table 4.1.

**Engineering Low (I/P2)**

[–999 to 9999]

**Note.** This parameter defaults to the minimum allowed value when THC input is selected – see Table 4.1.

**Broken Sensor Drive (I/P2)**

none – No action. Actual input values remain valid.  
 UP – Input driven to the maximum upscale value (999)  
 dN – Input driven to the minimum downscale value (–999)

**Filter Time Constant (I/P2)**

The input values are averaged over the time set.

[0 to 60 seconds]

Continued...

- 1 Frames 7.09 to 7.14 are not displayed if Analog Input Type 2 is set to 'OFF'.
- 2 Only displayed if THC input type is selected.



7.15 **Typ3** \*1

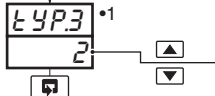

**Analog Input Type & Electrical Range (I/P3)**

Display	Description	Display	Description
OFF	Not Used	1	0 to 20mA
b	THC Type B	2	4 to 20mA
E	THC Type E	3	0 to 5V
J	THC Type J	4	1 to 5V
K	THC Type K	5	0 to 50mV
L	THC Type L	7	4 to 20mA square root linearizer
n	THC Type N	8	4 to 20mA power 3/2
r	THC Type R	9	4 to 20mA power 5/2
S	THC Type S	ii	Resistance feedback for motorized valve
t	THC Type T	U	Custom
P	PT100 RTD		

7.16 **Unit3** \*2

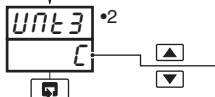

**Temperature Units**

- C - THC readings displayed in °C
- F - THC readings displayed in °F

7.17 **dP3**

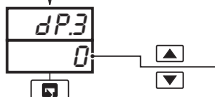

**Decimal Places**

- 0 XXXX
- 1 XXX.X
- 2 XX.XX
- 3 X.XXX

7.18 **En3H**

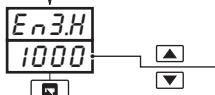

**Engineering High**

[-999 to 9999]

**Note.** This parameter defaults to the maximum allowed value when THC or RTD inputs are selected – see Table 4.1.

7.19 **En3L**



**Engineering Low**

[-999 to 9999]

**Note.** This parameter defaults to the minimum allowed value when THC or RTD inputs are selected – see Table 4.1.

7.20 **b5d3**

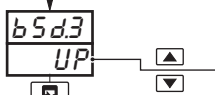

**Broken Sensor Drive (I/P3)**

- none - No action. Actual input values remain valid.
- UP - Input driven to the maximum upscale value (999)
- dN - Input driven to the minimum downscale value (-999)

7.21 **FLt3**

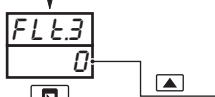

**Filter Time Constant (I/P3)**

The input values are averaged over the time set.

[0 to 60 seconds]

Return to top of page.



•1 Frames 7.16 to 7.21 are not displayed if Analog Input Type 3 is set to 'OFF'.

•2 Only displayed if THC or RTD input types are selected.



4.4 Level 8 – Alarms

**Note.** Any type of alarm can be used to sound an annunciator (klaxon/horn) which is disabled when the alarm is acknowledged. This is achieved by assigning the relay to the acknowledge state of the alarm instead of the actual alarm state.

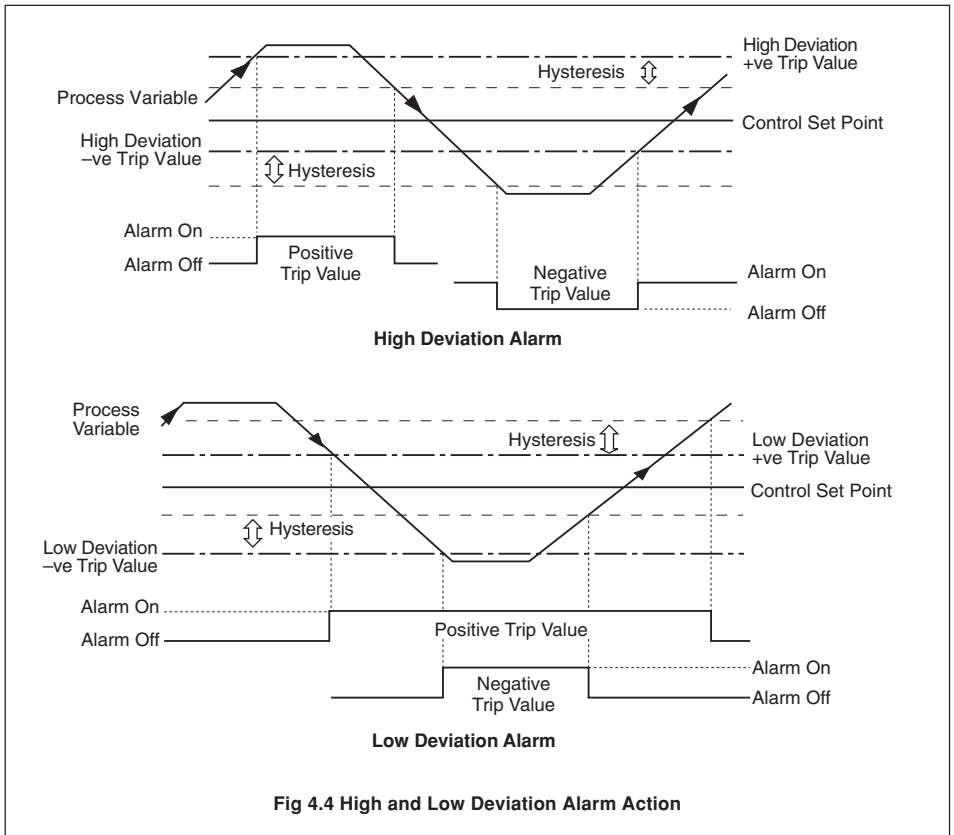
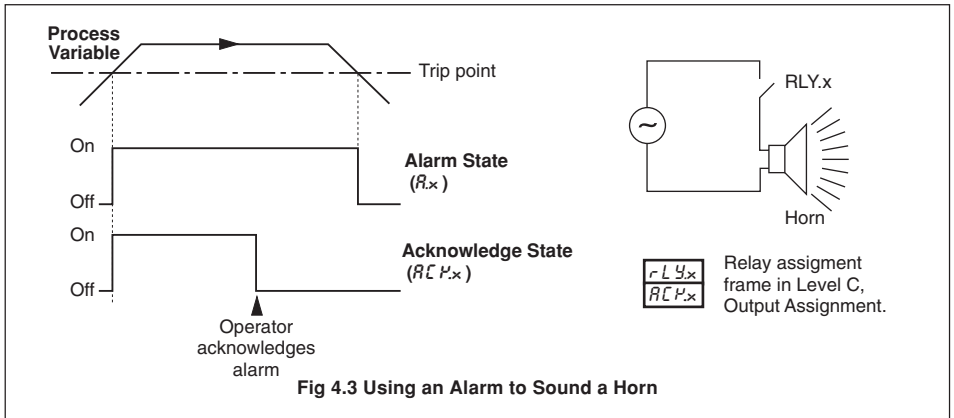



...4.4 Level 8 – Alarms

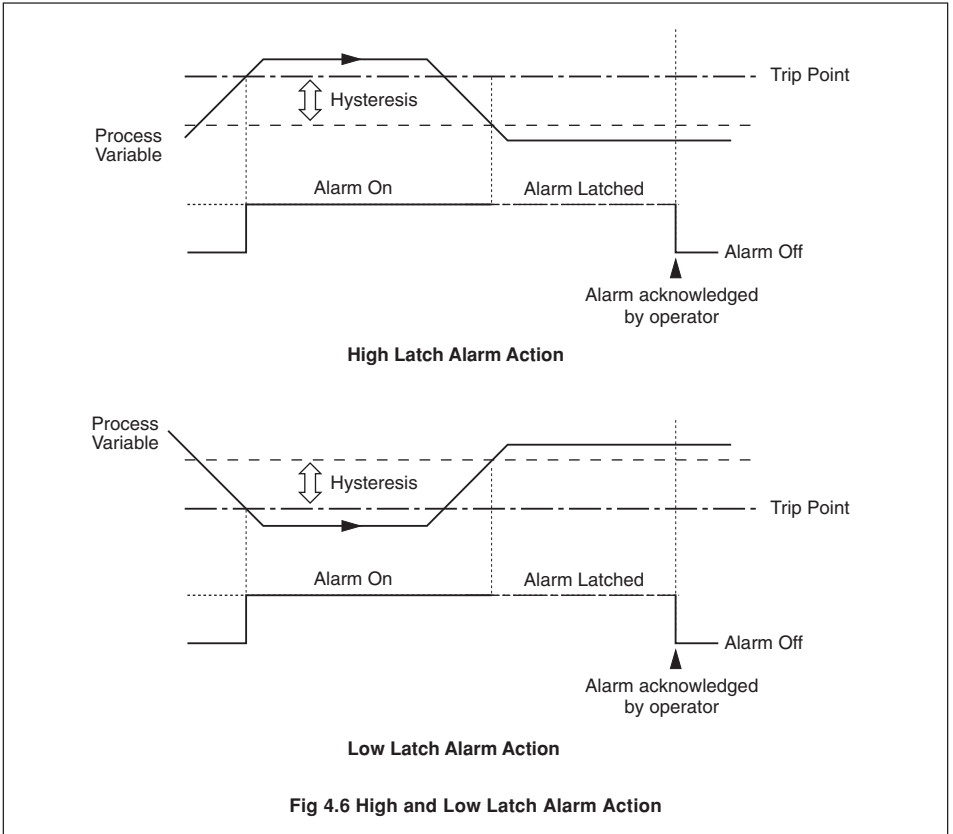
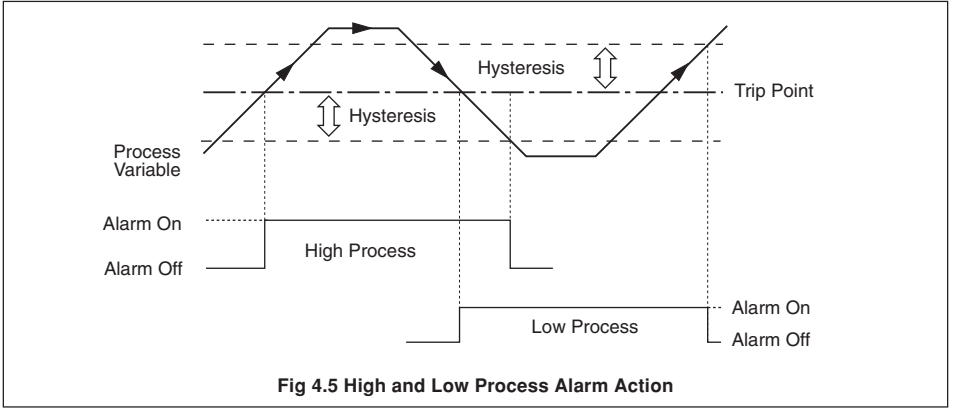



...4.4 Level 8 – Alarms

8.00...8.03

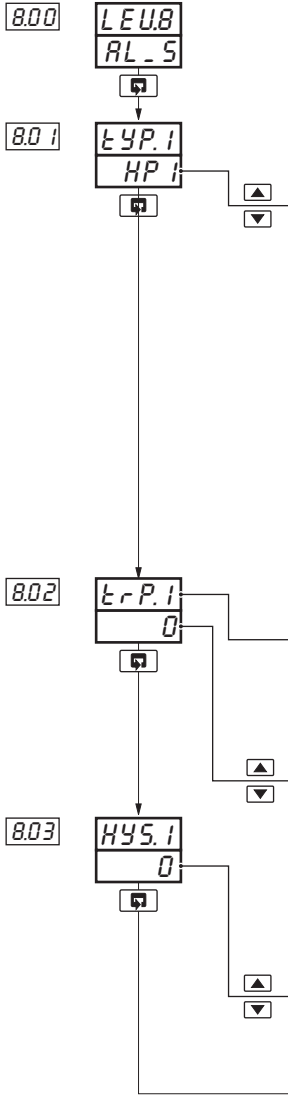

Level 8 – Alarms

**Note.** To select this frame from anywhere in this page, press the key for a few seconds.

Alarm 1 Type

See Figs 4.3 to 4.6

Display	Description	Display	Description
<i>NONE</i>	None	<i>LP3</i>	Low Process I/P3
<i>HPU</i>	High Process, PV	<i>HO</i>	High Output
<i>LPU</i>	Low Process, PV	<i>LO</i>	Low Output
<i>HLP</i>	High Latch, PV	<i>Hb 1</i>	Maths Block 1 High
<i>LLP</i>	Low Latch, PV	<i>Lb 1</i>	Maths Block 1 Low
<i>Hd</i>	High Deviation	<i>Hb 2</i>	Maths Block 2 High
<i>Ld</i>	Low Deviation	<i>Lb 2</i>	Maths Block 2 Low
<i>HP 1</i>	High Process I/P1	<i>Hb 3</i>	Maths Block 3 High
<i>LP 1</i>	Low Process I/P1	<i>Lb 3</i>	Maths Block 3 Low
<i>HP 2</i>	High Process I/P2	<i>Hb 4</i>	Maths Block 4 High
<i>LP 2</i>	Low Process I/P2	<i>Lb 4</i>	Maths Block 4 Low
<i>HP 3</i>	High Process I/P3		

**Note.** Alarm 1 is set automatically as a Low Process alarm on I/P2 when template 3 or 5 is selected.

Alarm 1 Trip

Alarm Number

Trip Value

[In engineering units]

Alarm 1 Hysteresis

Set the hysteresis value (in engineering units) for Alarm 1.

The alarm is activated at the trip level but is only deactivated when the process variable has moved into the safe region by an amount equal to the hysteresis value – see Figs. 4.4 to 4.6.

[In engineering units]

**Note.** Time hysteresis is set using the PC Configurator.

Continued...

•1 Applies to the PID output with single or heat/cool output types selected – see Section 3.4.

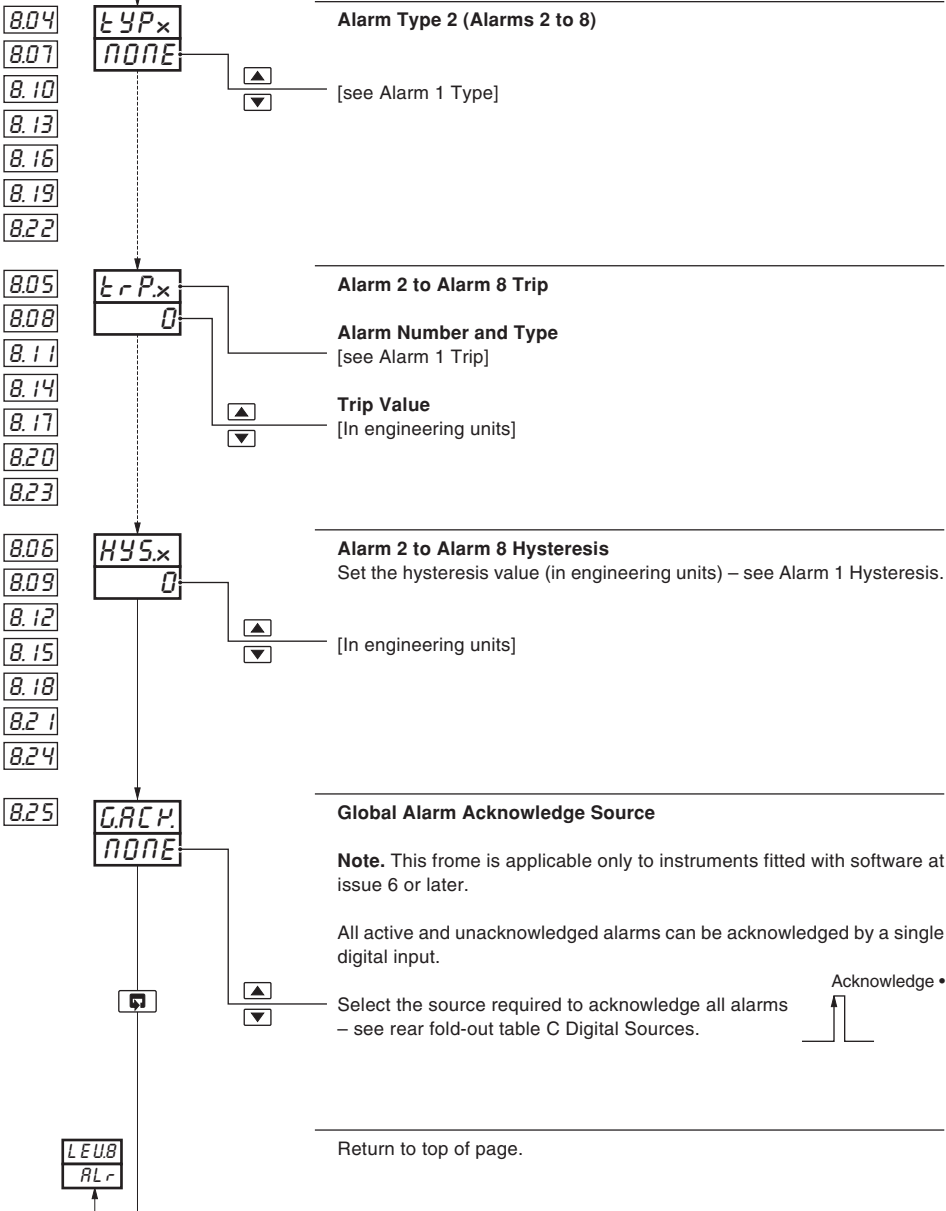

•1 A digital input becomes active when a volt-free contact is closed or a lowv TTL signal is applied.



## 4.5 Level 9 – Set Point Configuration

9.00...9.03

**Note.** Level 9 is not applicable when an Indicator template (templates 7 and 8) or an Auto/Manual station template (templates 3 and 4) is selected.

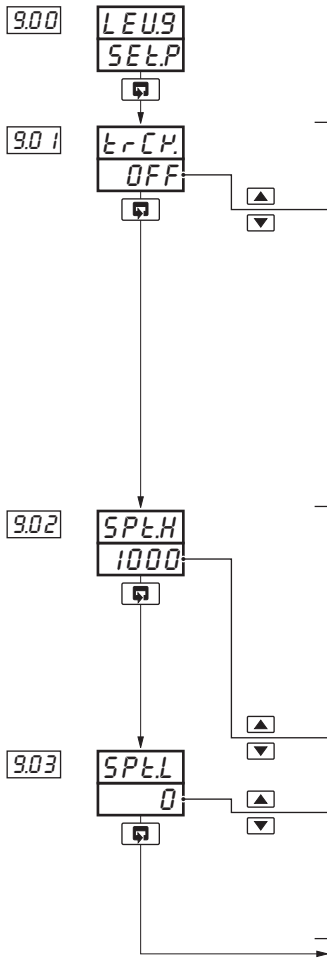

## Level 9 – Set Point Configuration

**Note.** To select this frame from anywhere in this page, press and hold the key for a few seconds.

## Set Point Tracking Enable

Display	Local Set Point Tracking	Remote Set Point Tracking
OFF	OFF	OFF
LOC	ON	OFF
rE_	OFF	ON
L-r	ON	ON

•1

•1

**Local Set Point Tracking** – the local set point tracks the process variable when manual mode is selected.

**Remote Set Point Tracking** – local set point tracks the remote set point when in remote set point mode. If the controller is put into manual mode the set point reverts from remote to local.

## Set Point Limits

The set point limits define the maximum and minimum values to which the local and/or remote set points can be adjusted. The set point limits do not apply when in Manual mode with local set point tracking enabled. If the set point is outside its limits when Automatic mode is selected, the set point value can only be adjusted towards its limits. Once within the limits they apply as normal.

## Control Set Point (CSPT) High Limit

[–999 to 9999 in engineering units]

## Control Set Point (CSPT) Low Limit

[–999 to 9999 in engineering units]

**Note.** Operator level adjustment of the set point can be disabled – see Section 4.7, Operator Configuration/ Set Point Adjustment Enable.

Continued...

•1 Only available if a remote set point template is selected.



...4.5 Level 9 – Set Point Configuration

9.05...9.11

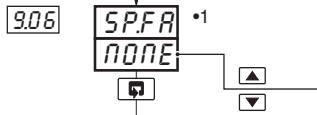

**Remote Set Point Fault Action**  
 The action required when a fault occurs with the remote set point.

*none* – No action  
*LOC* – Select local set point mode  
*dFLt* – Select local set point mode and set to the default value

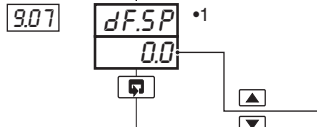

**Local Set Point Default Value**  
 Set the value required for the local set point under remote set point fault conditions.

[In engineering units]

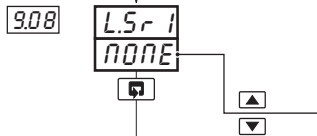

**Local Set Point Source 1**  
 The source required to select local set point 1 (LSP1) as the current local set point.

See Rear Fold-out/  
 Table C – Digital Sources.

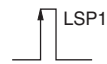

LSP1 •2

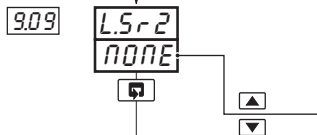

**Local Set Point Source 2**  
 The source required to select local set point 2 (LSP2) as the current local set point.

See Rear Fold-out/  
 Table C – Digital Sources.



LSP2 •2

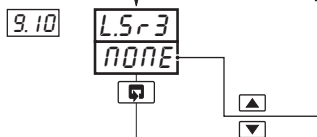

**Local Set Point Source 3**  
 The source required to select local set point 3 (LSP3) as the current local set point.

See Rear Fold-out/  
 Table C – Digital Sources.



LSP3 •2

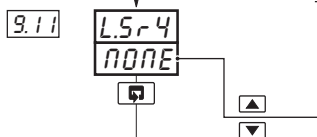

**Local Set Point Source 4**  
 The source required to select local set point 4 (LSP4) as the current local set point.

See Rear Fold-out/  
 Table C – Digital Sources.



LSP4 •2

Continued...

•1 Only displayed if a remote set point template is selected.

•2 A digital input becomes active when a volt-free contact is closed or a low TTL signal is applied.





...4.5 Level 9 – Set Point Configuration

9.12...9.14

9.12

Lr.Sr  
NONE



**Local/Remote Set Point Selection Source**

The source required to lock into remote set point mode. When the source is active the key does not operate.

See Rear Fold-out/  
Table C – Digital Sources.

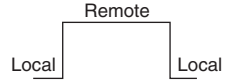

9.13

Lc.Sr  
NONE



**Local Set Point Selection Source**

The source required to select local set point mode.

See Rear Fold-out/  
Table C – Digital Sources.

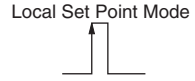

9.14

r.SrC  
NONE



**Remote Set Point Selection Source**

The source required to select remote set point mode.

See Rear Fold-out/  
Table C – Digital Sources.

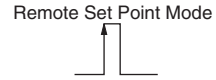

LEU9  
SEEP

Return to top of page.

•1 Digital inputs are active when a volt-free contact is closed or a low TTL signal is applied



### 4.6 Level A – Control Configuration

**Note.** Level A is not displayed if an indicator template is selected.

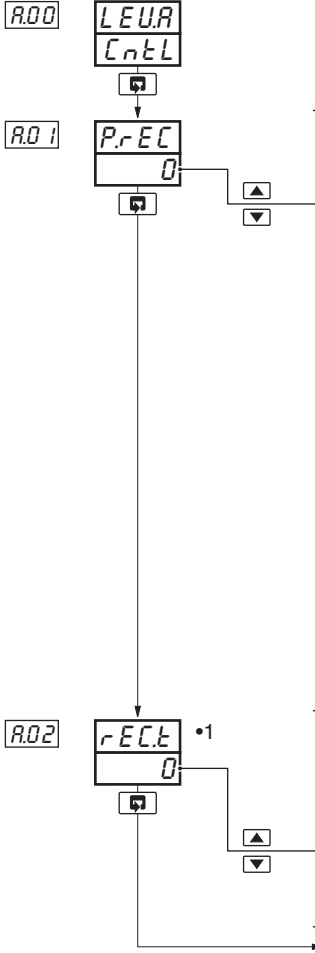

#### Level A – Control Configuration

**Note.** To select this frame from anywhere in this page, press and hold the key for a few seconds.

#### Power Fail Recovery Mode

Select the default power failure mode required following a power interruption or failure.

Display	Setting	Display	Setting
0	Last mode	5	Auto mode, integral term reset
1	Manual mode, using last output	6	Auto mode, using last integral term
2	Manual mode with 0.0% output	7	Power outage ≤ Recovery time: Auto mode. Power outage > Recovery time: Manual mode, last output
3	Manual mode with 100.0% output	8	Power outage ≤ Recovery time: Auto mode. Power outage > Recovery time: Manual mode, configured output
4	Manual mode with configured output		

#### Recovery Time

If power is restored within the recovery time, the controller continues in the last mode when power fail recovery modes 7 or 8 are selected.

[0 to 9999 seconds]

Continued...

\*1 Not displayed if power fail recovery modes 0 to 6 are selected.



## ...4.6 Level A – Control Configuration

R.03...R.08

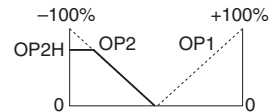
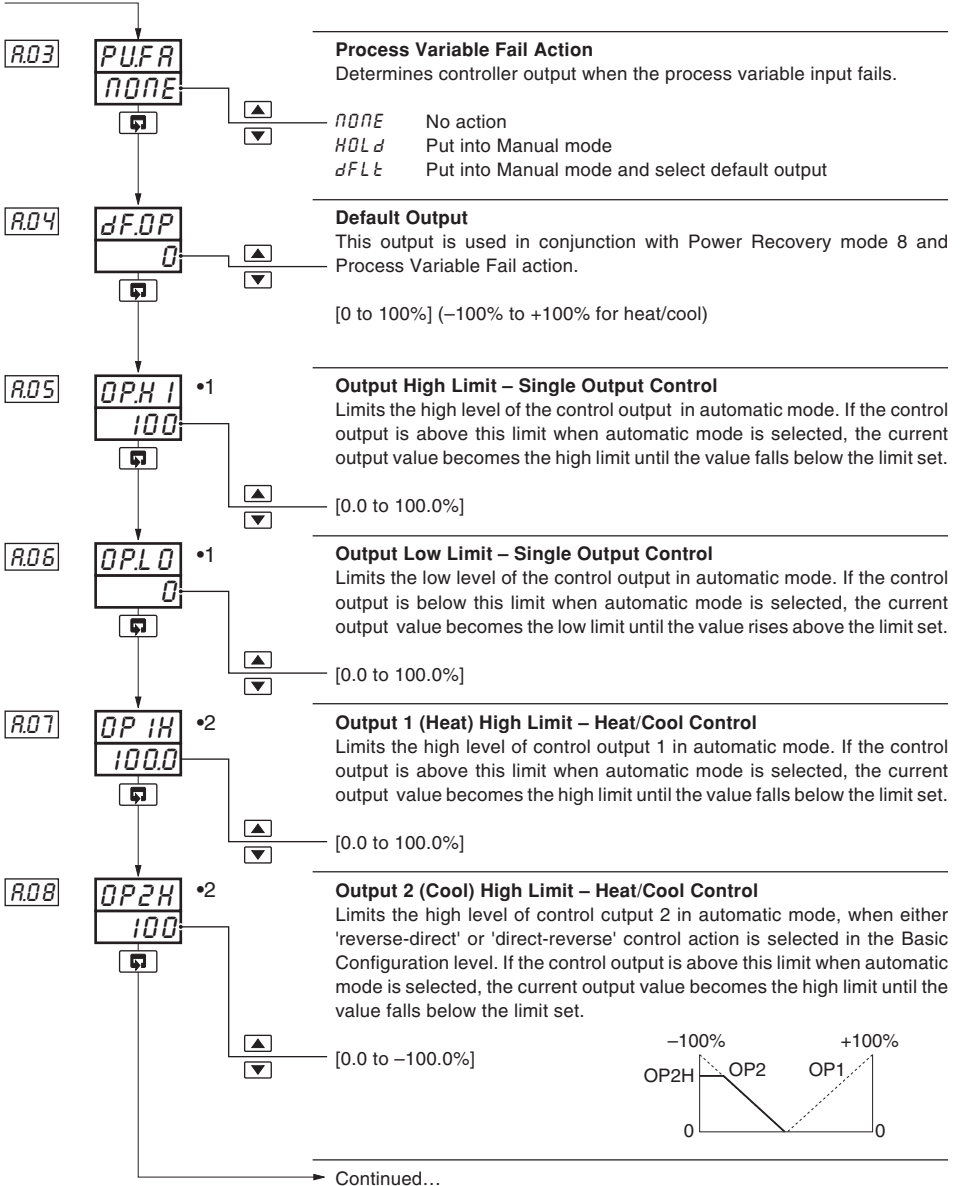

- 1 Only displayed if a single output type is selected.
- 2 Only displayed if a heat/cool output type is selected.

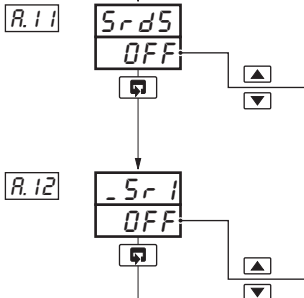
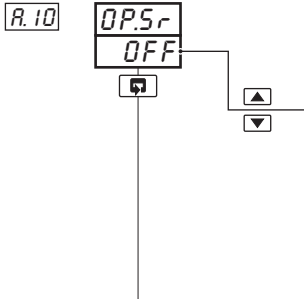
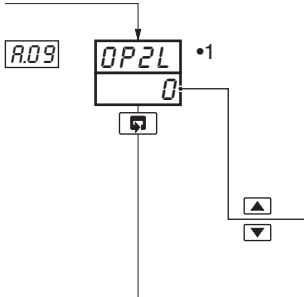

**Output 2 (Cool) Low Limit – Heat/Cool Control**

Limits the low level of control output 2 in automatic mode, when 'reverse-reverse' or 'direct-direct' control action is selected in the Basic Configuration level. If the control output is below this limit when automatic mode is selected, the current output value becomes the low limit until the value rises above the limit set.

[0 to 100%]

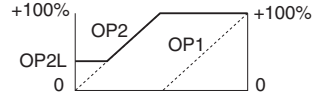

**Output Slew Rate**

The maximum rate of change of the control output (or both control outputs for heat/cool).

[0.01 to 99.99% change per second or 'OFF']

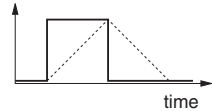

**Note.** The default slew rate setting is applied to both increasing and decreasing output values. The slew rate setting can be applied to either increasing values only or decreasing values only using the PC Configurator.

**Slew Rate Disable Source**

The digital source required to disable slew rate control of the output. See Rear Fold-out/ Table C – Digital Sources.

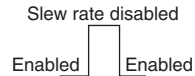

**Manual 1 Mode Selection Source**

The digital source required to select manual mode and Configured Output 1.

See Rear Fold-out/ Table C – Digital Sources.

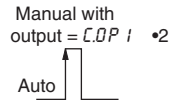

Continued...

- 1 Only displayed if reverse-reverse or direct-direct control actions are selected.
- 2 Digital inputs are active when a volt free contact is closed or a low TTL signal is applied.





...4.6 Level A – Control Configuration

R.18...R.22

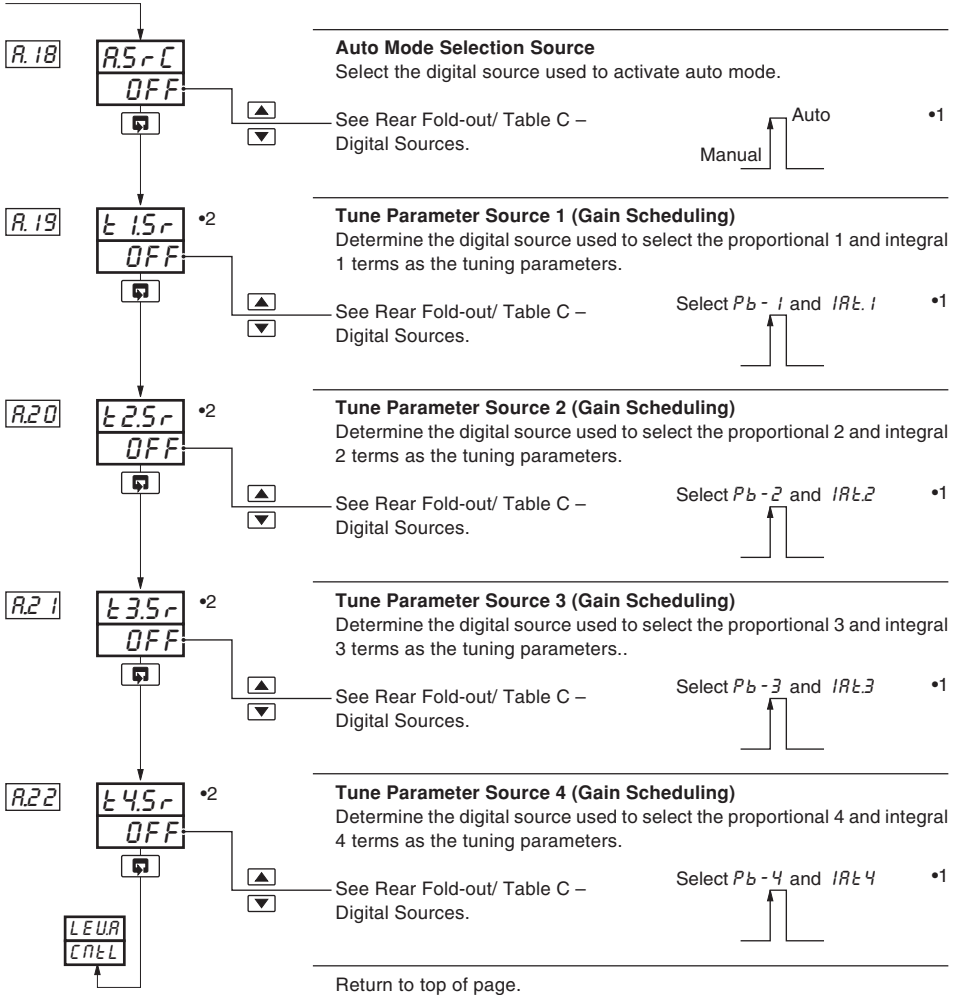

•1 Digital inputs are active when a volt free contact is closed or a low TTL signal is applied.

•2  $PB-x$  and  $IAt.x$  values are set in Level 2 – see Section 3.2, Tune/Proportional Band x and Integral Action Time x. This function is not available with Cascade control and it is not applicable to Auto/Manual Station, Indicator or Ratio Station templates.



## 4.7 Level B – Operator Configuration

b.00...b.06

b.00

LEU**b**  
OPE**r**



## Level B – Operator Configuration

**Note.** To select this frame from anywhere in this page, press and hold the key for a few seconds.

b.01

FPA**r** \*1  
YES



## Front Panel Auto/Manual Key Enable

YES – Enabled  
NO – Disabled

b.02

FPL**r** \*1  
L**r**



## Front Panel Local/Remote Key Enable

Display	Local/Remote Key Action
NO	Local/Remote key disable.
Lr	Switches between local and remote set point modes.
2L	Selects local set point 1 or 2.
3L	Selects local set point 1, 2 or 3.
4L	Selects local set point 1, 2, 3 or 4.

b.03

FPA**A**  
YES



## Front Panel Alarm Acknowledge Key Enable

YES – Enabled  
NO – Disabled

b.04

S**A**D**J** \*1  
YES



## Operator Level Set Point Adjustment Enable

YES – Enabled  
NO – Disabled

b.05

r**d** 15 \*1  
NO \*2



## Operator Ratio Display

YES – Ratio setting for Remote set point displayed in the operator level.  
NO – Ratio setting for Remote set point not displayed in the operator level.

b.06

b**d** 15 \*1  
NO \*2



## Operator Bias Display

YES – Bias setting for Remote set point displayed in operator level.  
NO – Bias setting for Remote set point not displayed in operator level.

Continued...

\*1 Not displayed if the Indicator template in use.

\*2 Only displayed if a template with remote set point is selected.



...4.7 Level B – Operator Configuration

b.07...b.13

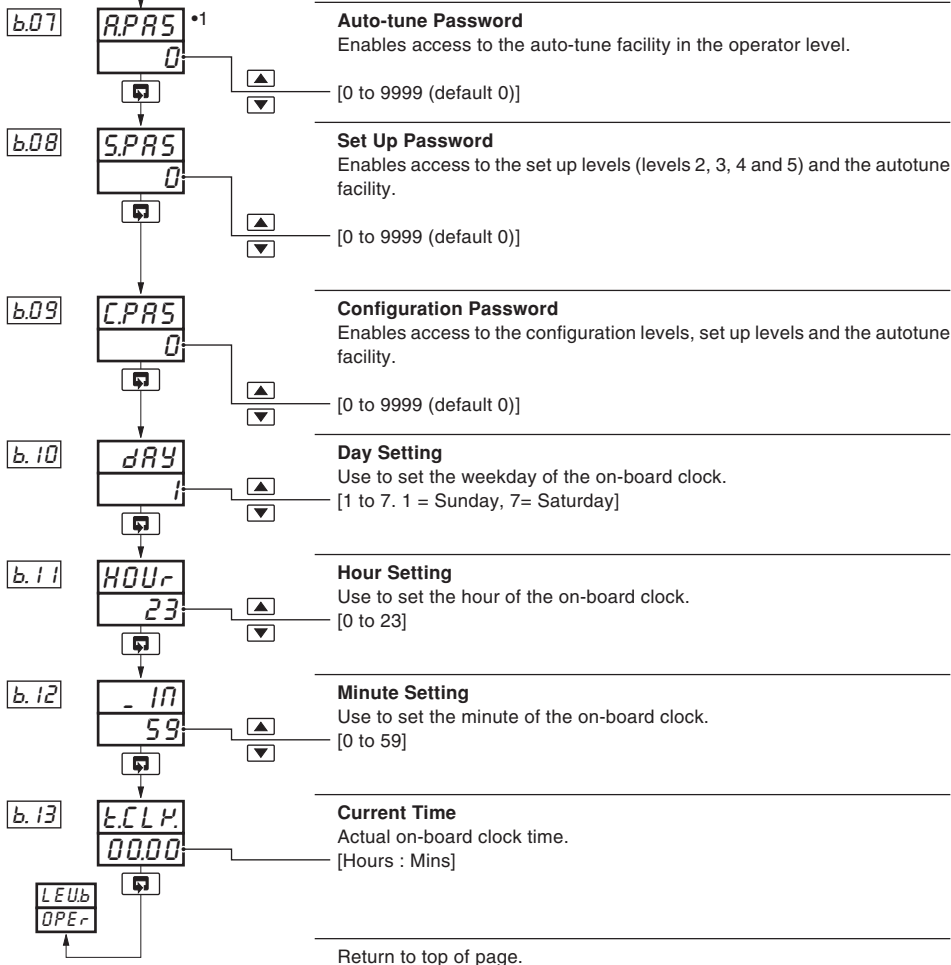

\*1 Not displayed on Indicator or Auto/manual station templates.





## 4.8 Level C – Output Assignment Configuration

C.00, C.01, C.07, C.08

**Note.** The Output Assignment default settings are preconfigured to each template – see Table B, Output Sources on the rear fold-out.

C.00

LEUC  
RSSn



## Level C – Output Assignment

**Note.** To select this frame from anywhere in this page, press the  key for a few seconds.

C.01

EYP.1 \*1  
ANLG



## Analog/Digital Output 1 (ao1/do1) Type

Select the output type for Output 1.

ANLG - Analog  
DIG - Digital

ANLA  
NONE

Press  to advance to Analog Output 1 Assignment Source.

or

DIG



DIGLA  
NONE

Press  to advance to Digital Output 1 Assignment Source.

## 4.8.1 Digital Output 1

EYP.1  
DIG

C.07

DIGLA \*1  
NONE



## Digital Output 1 (do1) Assignment Source

Select the source required to activate Digital Output 1

See Rear Fold-out/ Table C – Digital Sources.

C.08

DIGIP \*2  
POS



## Digital Output 1 (do1) Polarity

The output can be set to energize for either an active or inactive digital signal.

POS - Output energized when source is active.  
NEG - Output energized when source is inactive.

EYP.2  
ANLG

Continued...

•1 If the output is assigned to a control output by the control type, the setting displayed cannot be changed – see Section 4.2, Basic Configuration/ Control Output Type.

•2 Not applicable if digital output 1 is assigned to a control output.



### 4.8.2 Analog Output 1

C02...C06

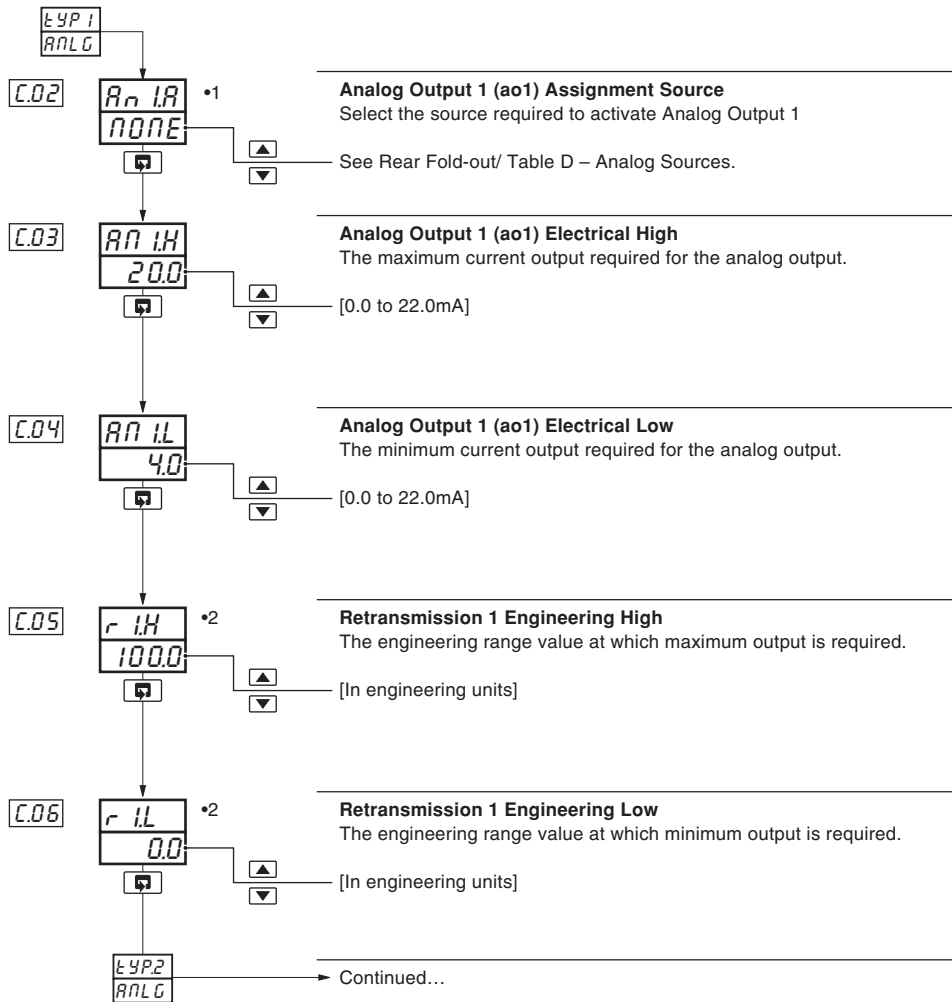

•1 If the output is assigned to a control output by the control type, the setting displayed cannot be changed – see Section 4.2, Basic Configuration/ Control Output Type.

•2 Not applicable if analog output 1 is assigned to a control output.



## 4.8.3 Output 2 Assignment

C09, C15, C16

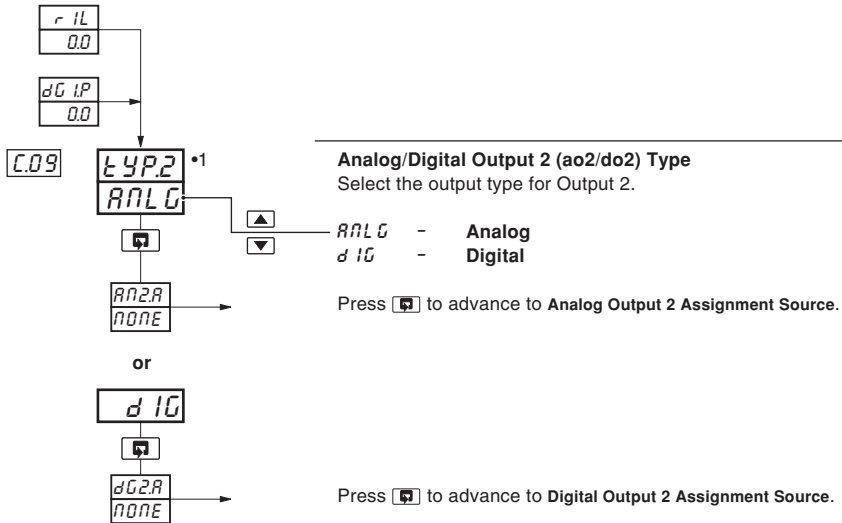

## 4.8.4 Digital Output 2

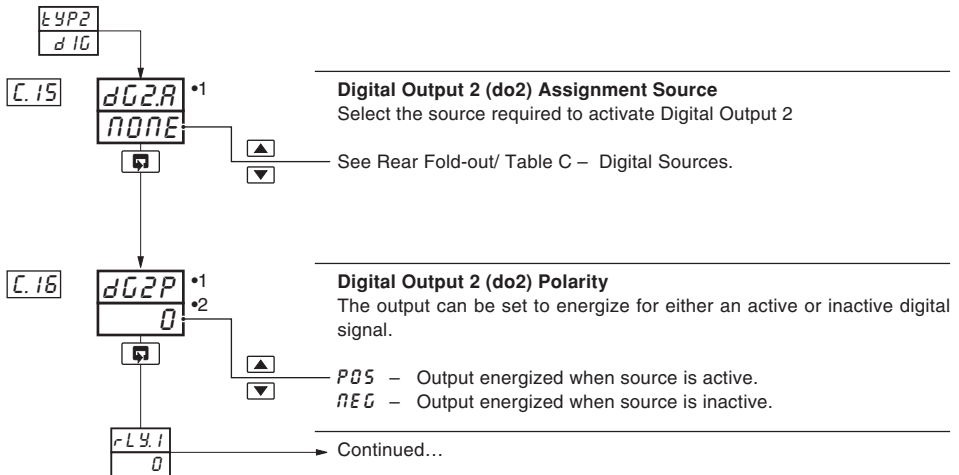

- 1 Only displayed if optional output is fitted. If the output is assigned to a control output by the control type, the setting displayed cannot be changed – see Section 4.2, Basic Configuration/ Control Output Type.
- 2 Not applicable if digital output 2 is assigned to a control output.



4.8.5 Analog Output 2

C10...C14

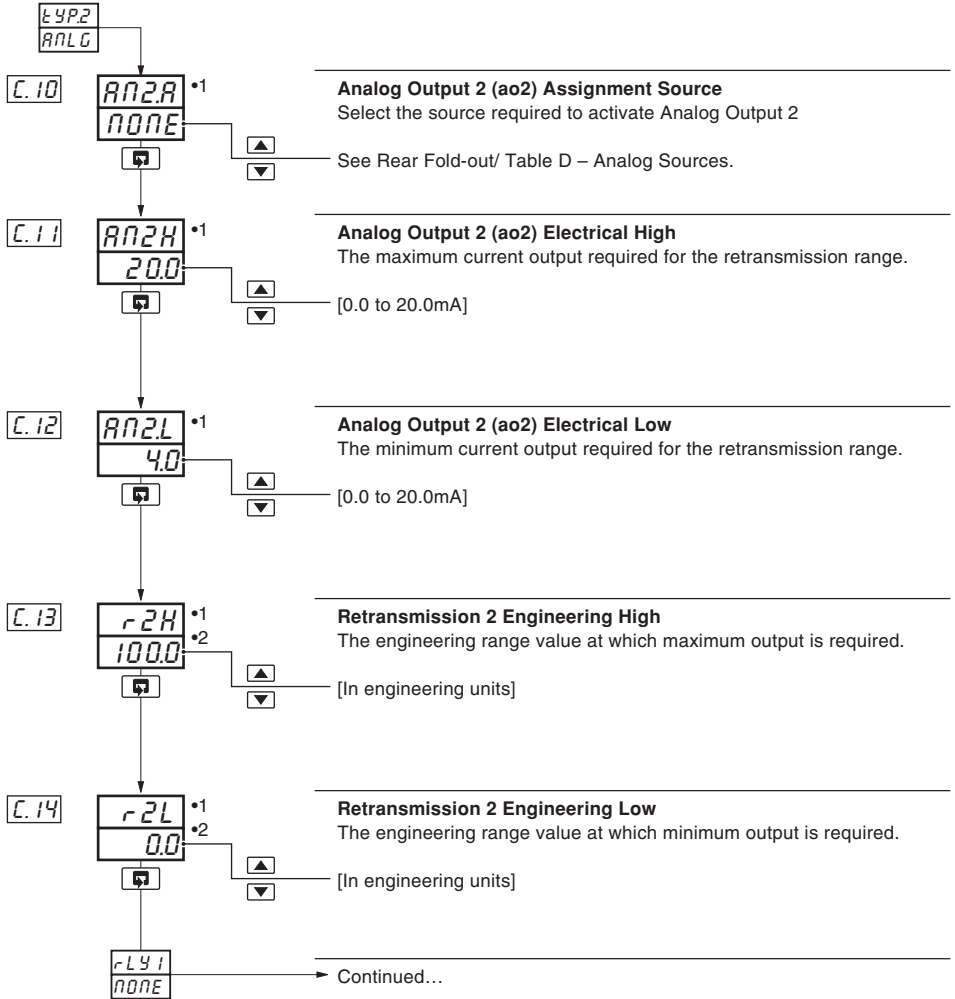

•1 Only displayed if optional output is fitted. If the output is assigned to a control output by the control type, the setting displayed cannot be changed – see Section 4.2, Basic Configuration/ Control Output Type.

•2 Not applicable if analog output 2 is assigned to a control output.



## 4.8.6 Relay Outputs 1 to 4

C17...C22

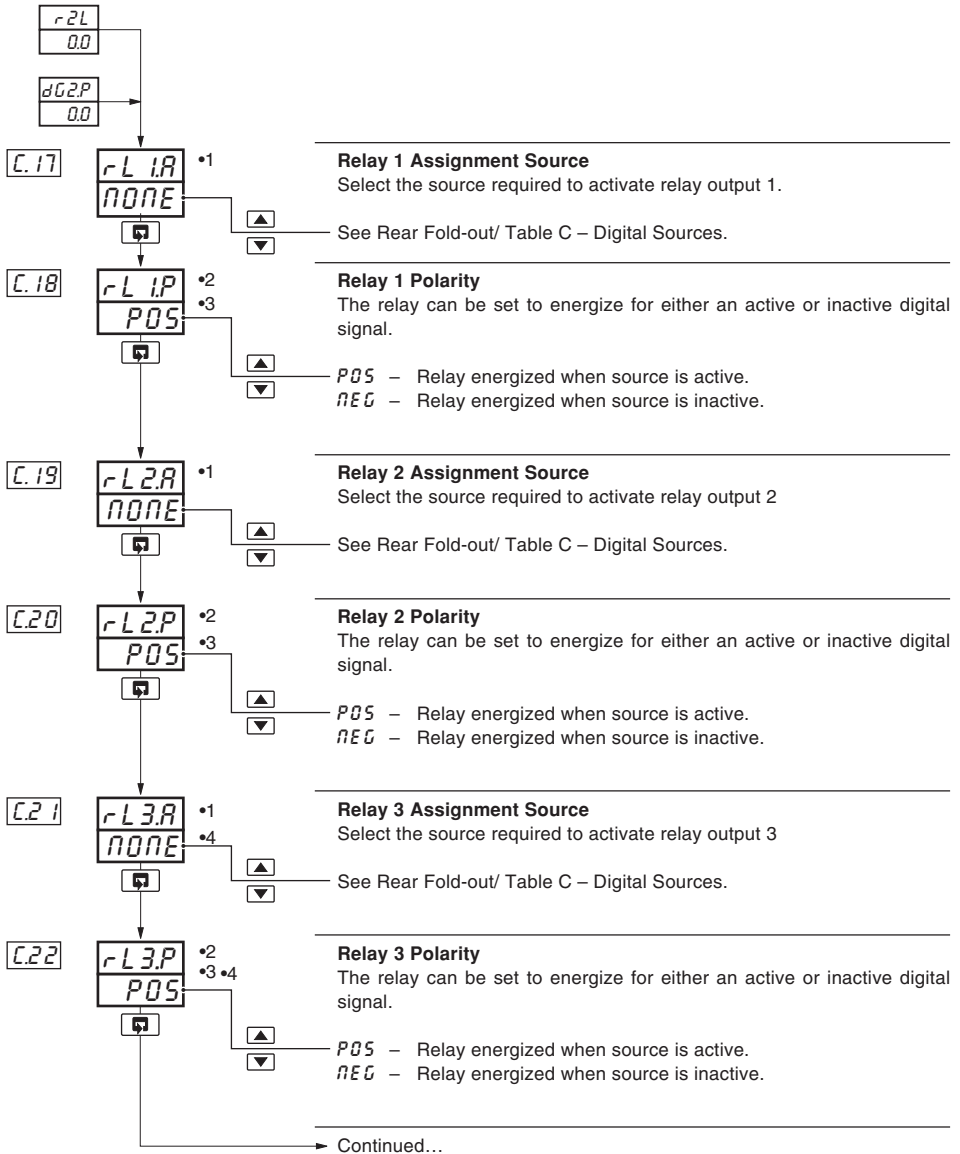

- 1 If the output is assigned to a control output by the control type, the setting displayed cannot be changed – see Section 4.2, Basic Configuration/ Control Output Type.
- 2 Not displayed if relay is assigned to a control output signal.
- 3 Not applicable if relay is assigned to a control output.
- 4 Only displayed if optional relay output is fitted.



...4.8.6 Relay Outputs 1 to 4

C23...C24

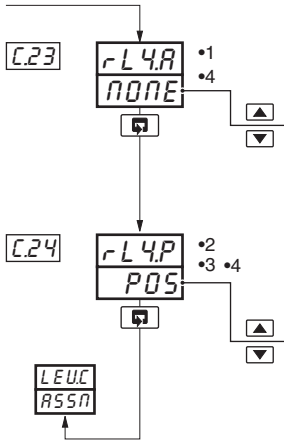

---

**Relay 4 Assignment Source**  
 Select the source required to activate relay output 4

See Rear Fold-out/ Table C – Digital Sources.

---

**Relay 4 Polarity**  
 The relay can be set to energize for either an active or inactive digital signal.

*POS* – Relay energized when source is active.  
*NEG* – Relay energized when source is inactive.

Return to top of page.

- 1 If the output is assigned to a control output by the control type, the setting displayed cannot be changed – see Section 4.2, Basic Configuration/ Control Output Type.
- 2 Not displayed if relay is assigned to a control output signal.
- 3 Not applicable if relay is assigned to a control output.
- 4 Only displayed if relay output is fitted.



## 4.9 Level D – Serial Communications Configuration

d.00...d.03

**Note.** Level D is only applicable if the serial communications option is fitted.

d.00

LEUd  
SErL



## Level D – Serial Communications Configuration

**Note.** To select this frame from anywhere in this page, press and hold the  key for a few seconds.

d.01

S.C.F.G  
0



## Serial Configuration

- 0 – Off
- 1 – 2-wire connection, 2400 baud rate
- 2 – 4-wire connection, 2400 baud rate
- 3 – 2-wire connection, 9600 baud rate
- 4 – 4-wire connection, 9600 baud rate
- 5 – 2-wire connection, 19200 baud rate
- 6 – 4-wire connection, 19200 baud rate

d.02

P.r.t.Y  
NONE



## Parity

- NONE – None
- Odd – Odd
- EVEN – Even

d.03

Addr  
1



## MODBUS™ Address

Each slave on a MODBUS link must be assigned a unique address – see *IM/C500-MOD*.

[1 to 99]

LEUd  
SErL

Return to top of page.



4.10 Level E – Calibration

E.00...E.04

**Note.** This page enables fine tuning of the inputs to eliminate system errors.

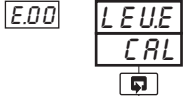

Level E – Calibration

**Note.** To select this frame from anywhere in this page, press the key for a few seconds.



Analog Input 1 Offset Calibration

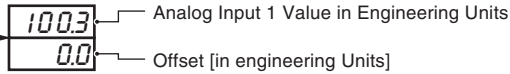

If the and keys are not operated for three seconds the display reverts to the offset value only.



Analog Input 1 Span Calibration

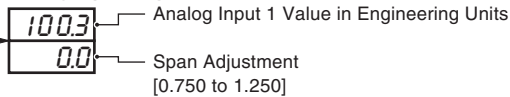

If the and keys are not operated for three seconds the display reverts to the span value only.



Analog Input 2 Offset Calibration

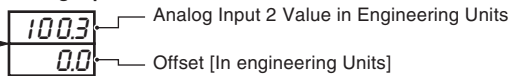

If the and keys are not operated for three seconds the display reverts to the offset value only.



Analog Input 2 Span Calibration

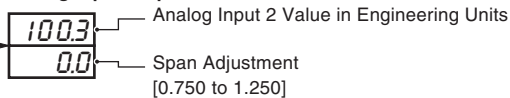

If the and keys are not operated for three seconds the display reverts to the offset value only.

Continued...





## ...4.10 Level E – Calibration

E.05...E.10

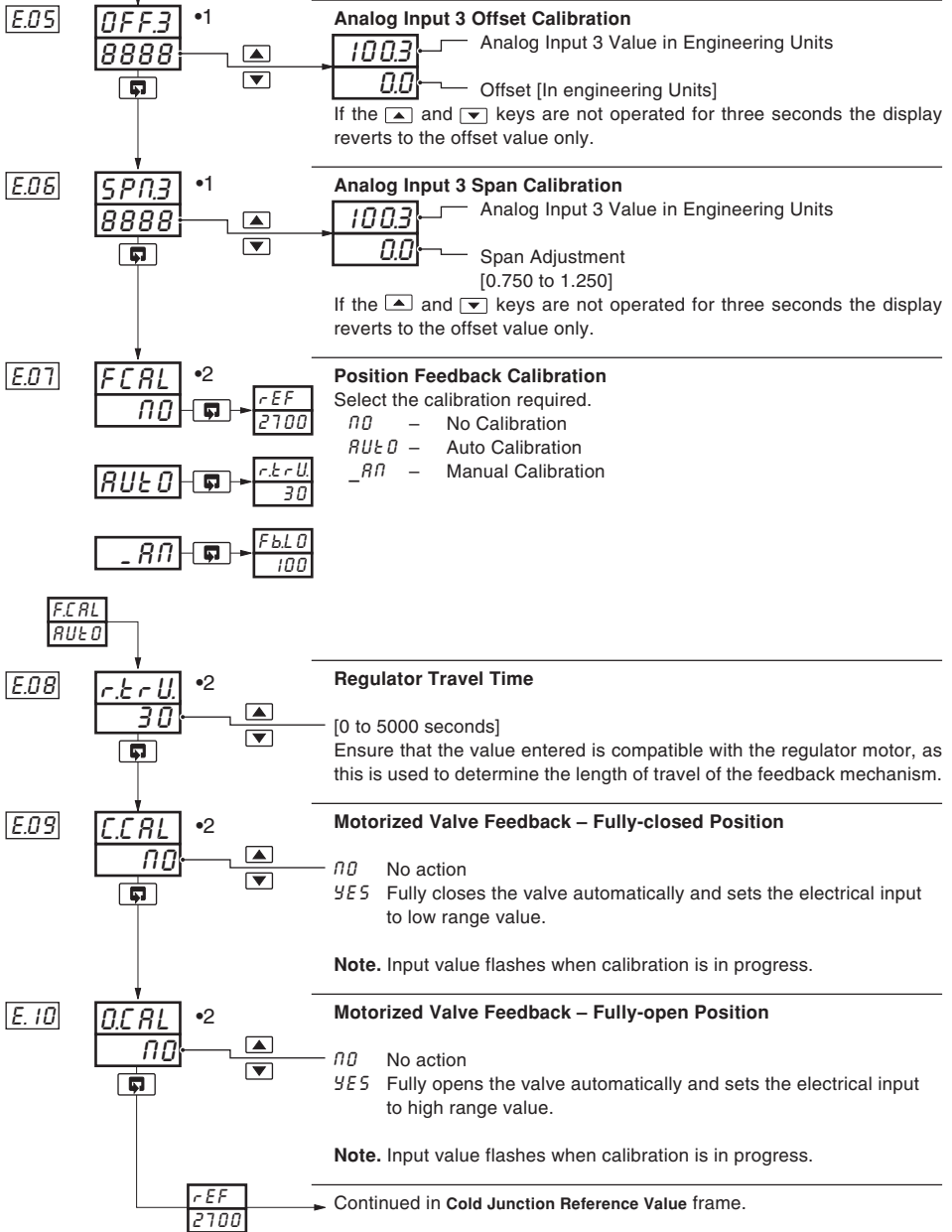

•1 Only displayed if option board is fitted.

•2 Only displayed if Motorized Valve with feedback output type is selected – see Section 4.2, Basic Configuration.



...4.10 Level E – Calibration

E.11 ...E.16

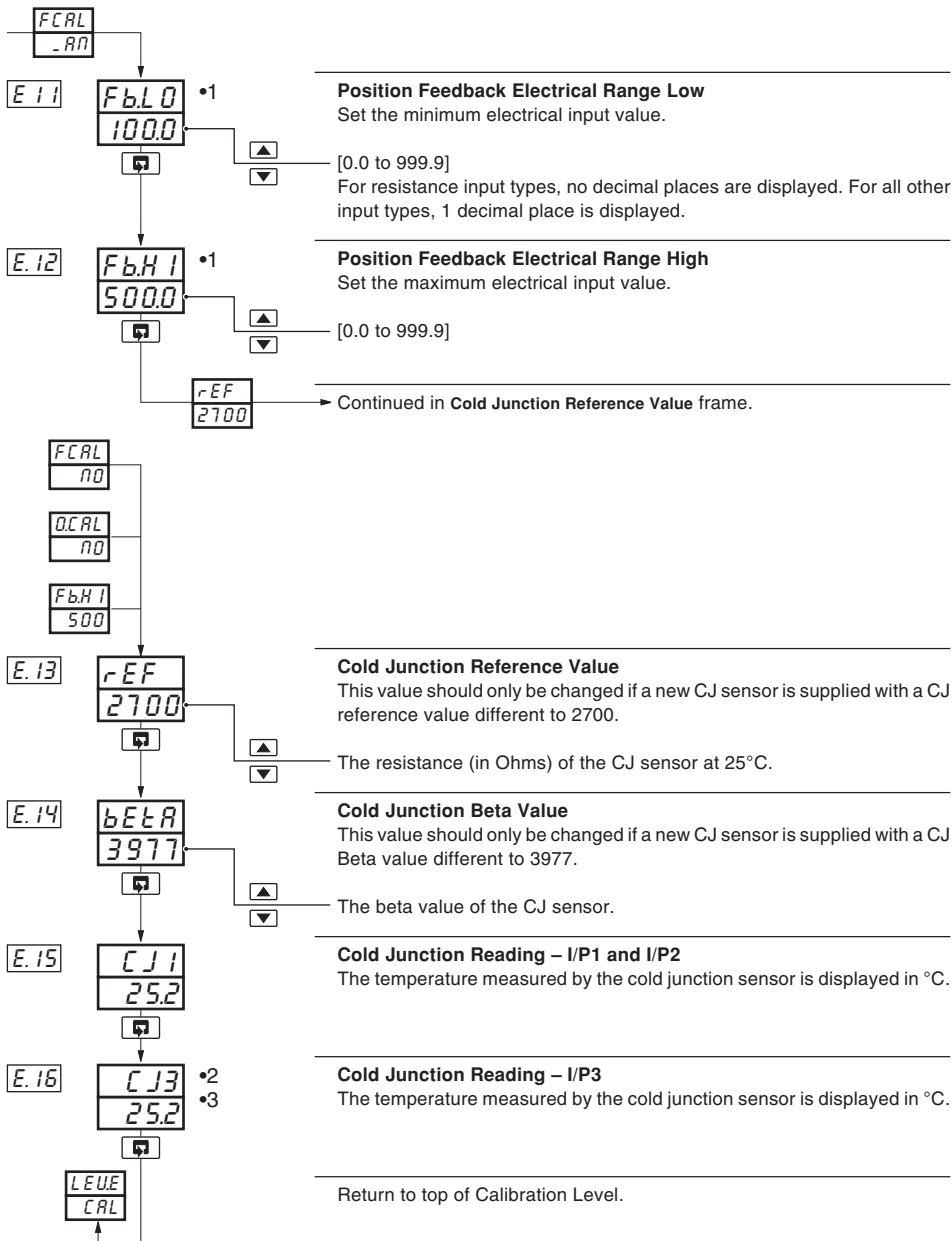

- 1 Only displayed if Motorized Valve with feedback output type is selected – see Section 4.2, Basic Configuration.
- 2 Only displayed if corresponding input type is set to 'THC'.
- 3 Only displayed if option board is fitted.

# 5 INSTALLATION



## EC Directive 89/336/EEC

In order to meet the requirements of the EC Directive 89/336/EEC for EMC regulations, this product must not be used in a non-industrial environment.

### End of Life Disposal

- The instrument contains a small lithium battery which should be removed and disposed of responsibly in accordance with local environmental regulations.
- The remainder of the instrument does not contain any substance that will cause undue harm to the environment and may therefore be considered as normal waste and disposed of accordingly.

### Cleaning

Clean only the front panel, using warm water and a mild detergent.

## 5.1 Mechanical Installation

### 5.1.1 Siting – Figs. 5.1 and 5.2

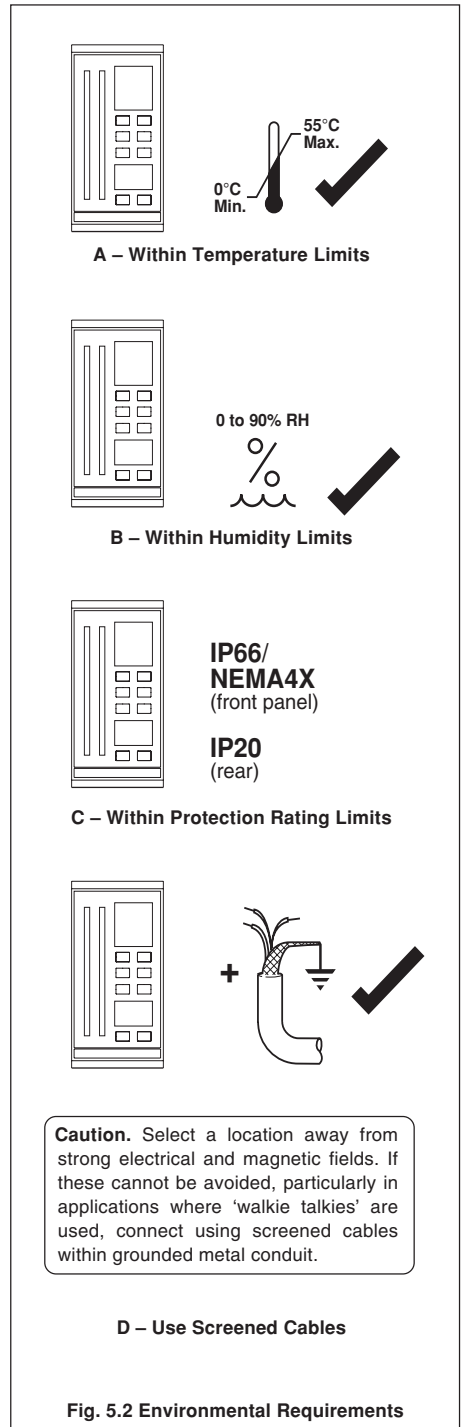
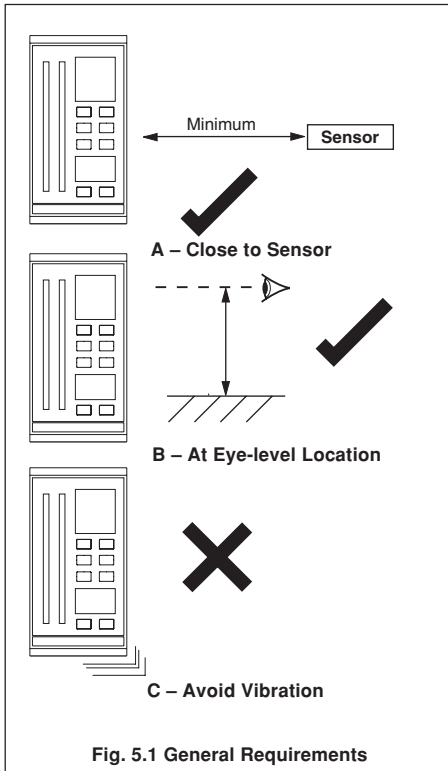



### 5.1.2 Mounting – Figs. 5.3 to 5.5

The instrument is designed for panel mounting (Fig. 5.4). Overall dimensions are shown in Fig. 5.3.

**Note.** For NEMA4X protection, a minimum panel thickness of 2.5mm is recommended.

Dimensions in mm (in.)

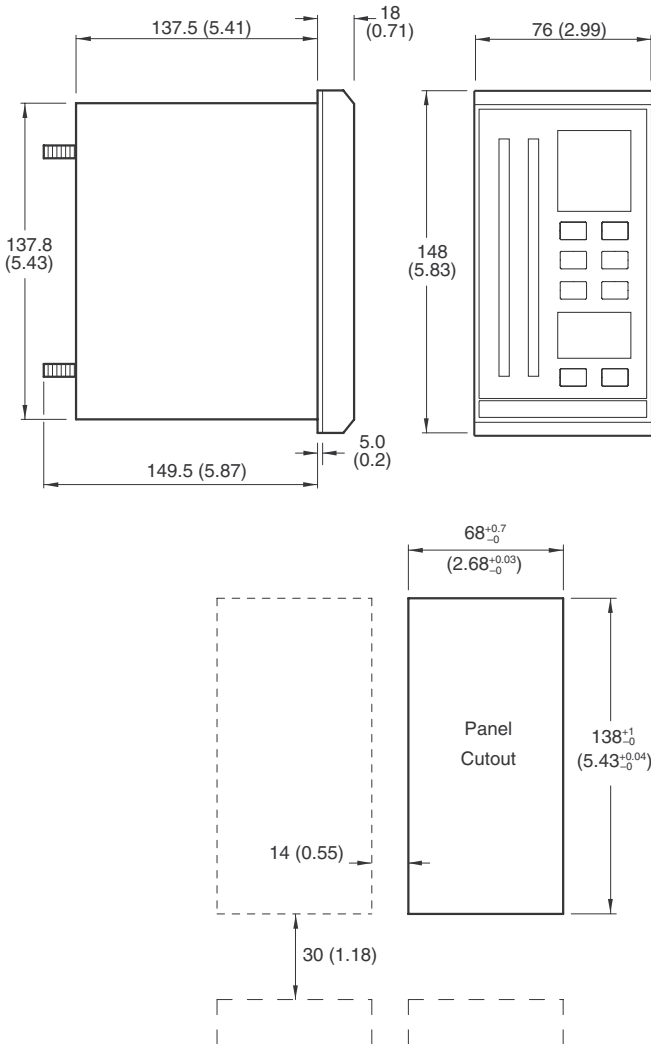

Fig. 5.3 Overall Dimensions



## ...5.1.2 Mounting – Figs. 5.3 to 5.5

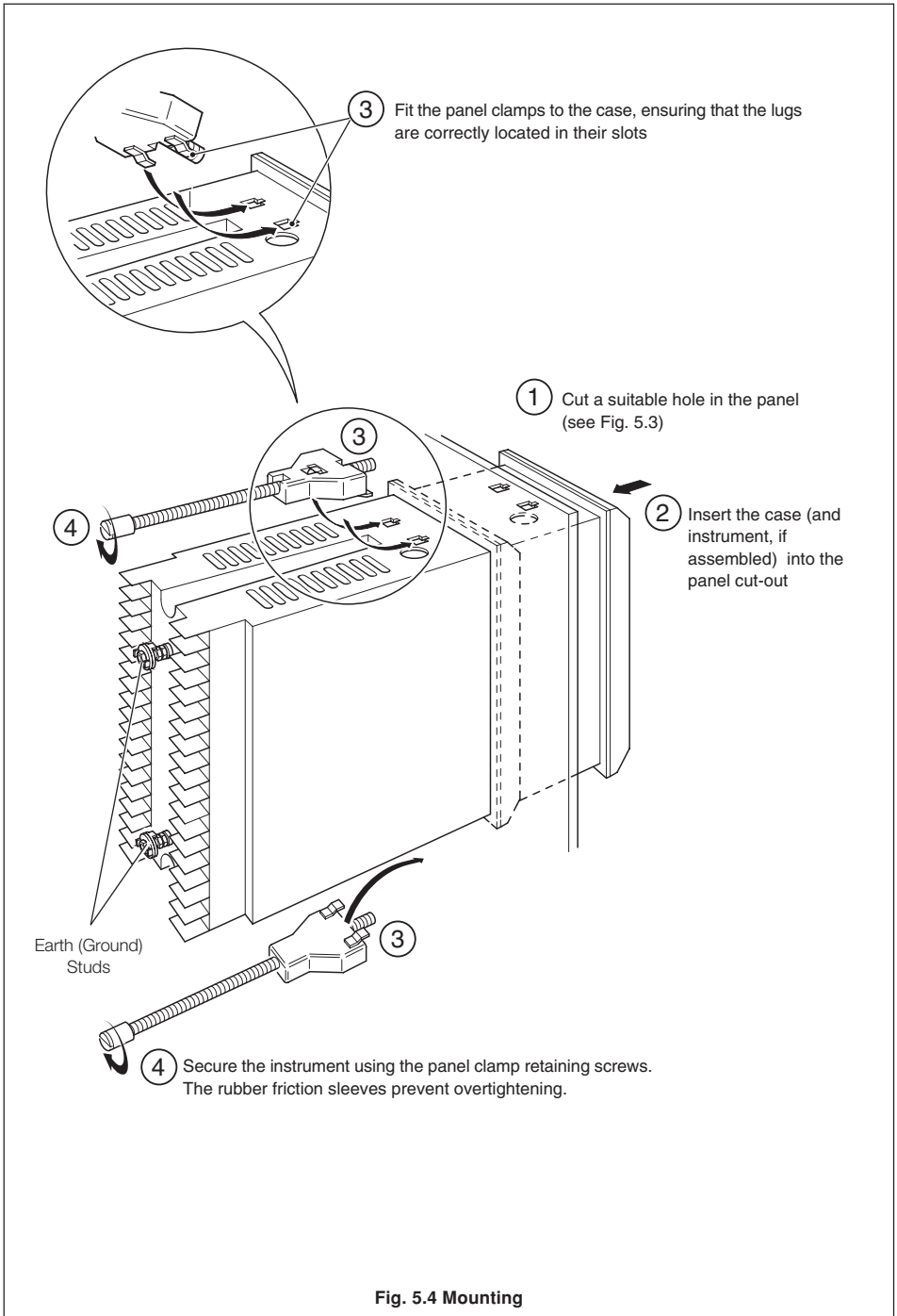
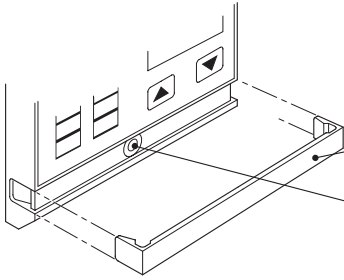

Fig. 5.4 Mounting



...5.1.2 Mounting – Figs. 5.3 to 5.5



- 1 Unclip the process label cover and remove the process label, if fitted.
- 2 Loosen the captive screw securing the instrument to the case

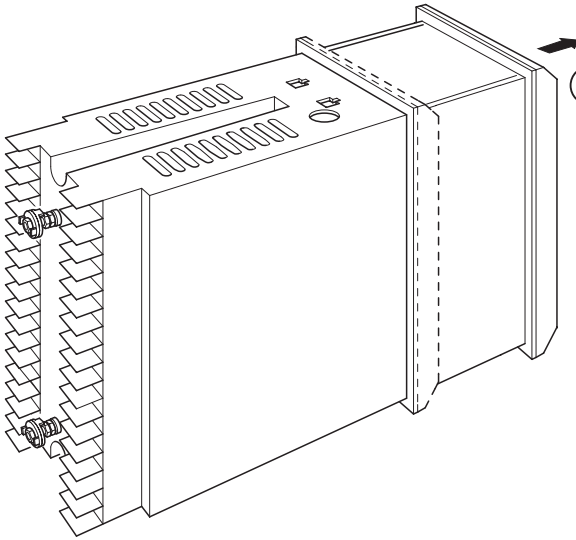

- 3 Remove the instrument from the case

**Note.** Refitting is the reversal of removal.

Fig. 5.5 Inserting/Removing the Instrument from the Case



### 5.1.3 Process Labels – Fig. 5.6

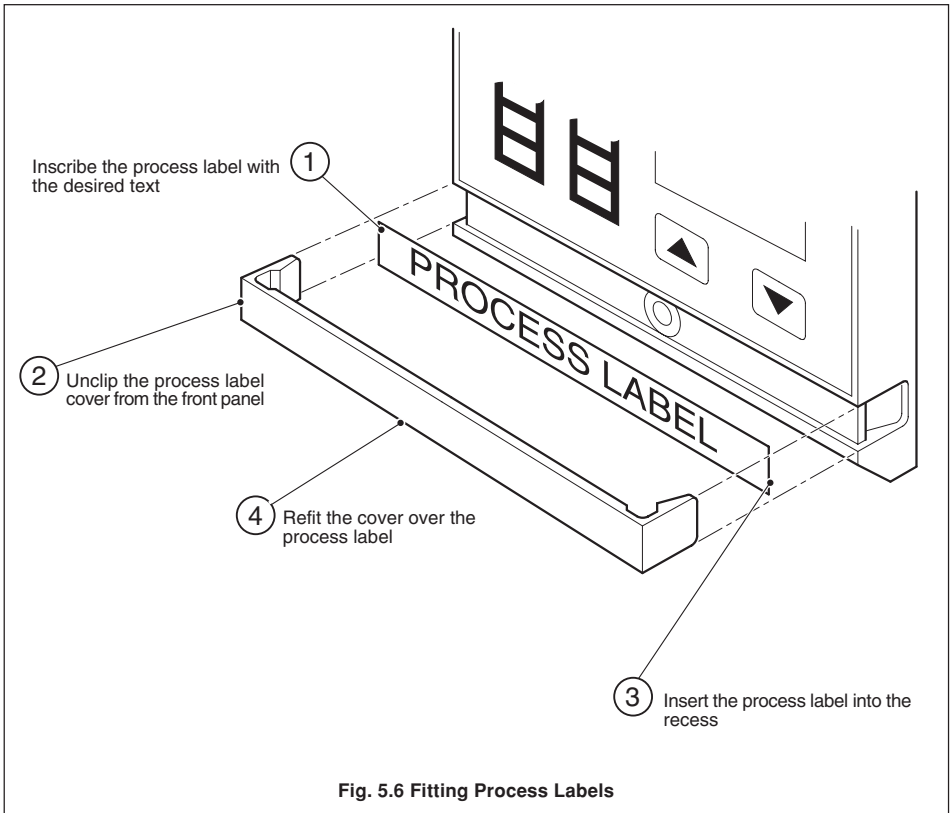

Fig. 5.6 Fitting Process Labels



## 5.2 Electrical Installation

---



### Warnings.

- The instrument is not fitted with a switch therefore a disconnecting device such as a switch or circuit breaker conforming to local safety standards must be fitted to the final installation. It must be fitted in close proximity to the instrument within easy reach of the operator and must be marked clearly as the disconnection device for the instrument.
  - Remove all power from supply, relay and any powered control circuits and high common mode voltages before accessing or making any connections.
  - Use cable appropriate for the load currents. The terminals accept cables up to 14AWG (2.5mm<sup>2</sup>).
  - The instrument conforms to Mains Power Input Insulation Category II. All other inputs and outputs conform to Category II.
  - All connections to secondary circuits must have basic insulation.
  - After installation, there must be no access to live parts e.g. terminals.
  - Terminals for external circuits are for use only with equipment with no accessible live parts.
  - If the instrument is used in a manner not specified by the Company, the protection provided by the equipment may be impaired.
  - All equipment connected to the instrument's terminals must comply with local safety standards (CEI/IEC 61010-1:2001-2).
- 

### Notes.

- Always route signal leads and power cables separately, preferably in earthed (grounded) metal conduit.
  - It is strongly recommended that screened cable is used for signal inputs and relay connections. Connect the screen to the earth (ground stud) – see Fig. 5.4.
  - The battery is a 3V non-replaceable lithium cell.
- 



This equipment is protected through double insulation (Class II).

---





## 5.2.1 Electrical Connections – Figs 5.7 to 5.9

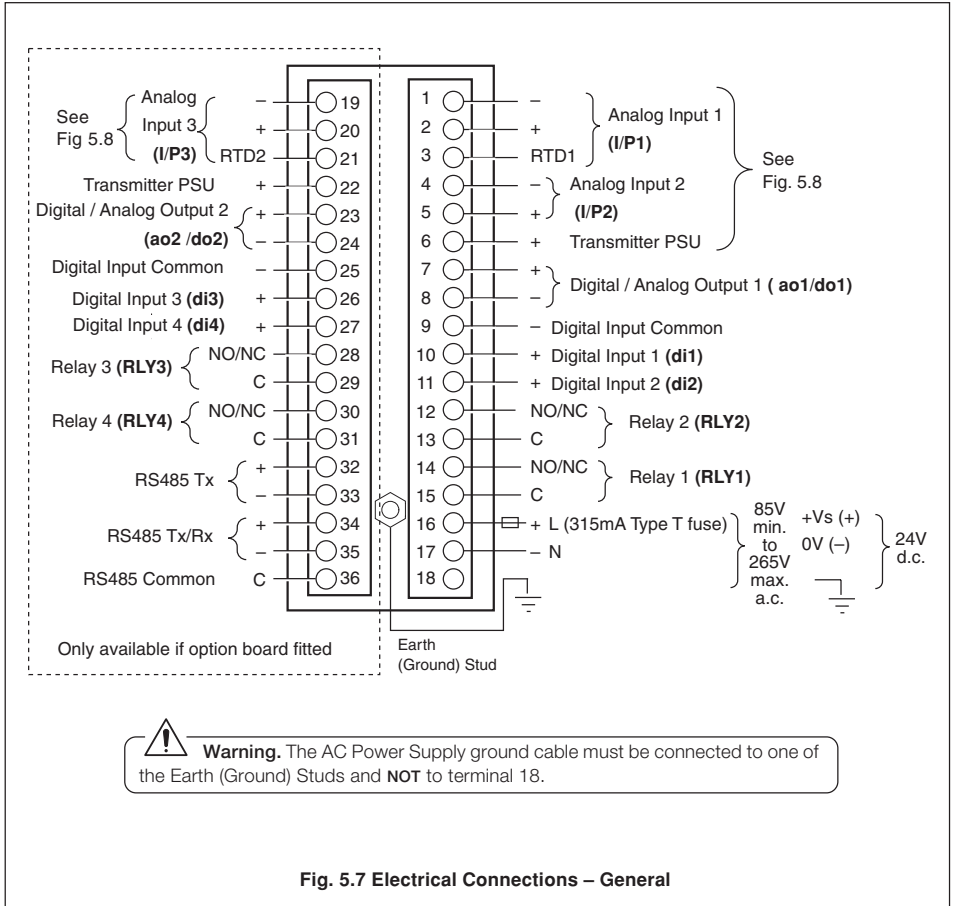
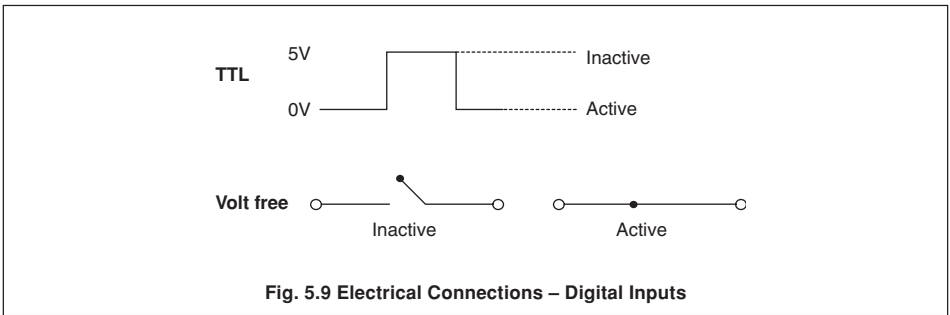
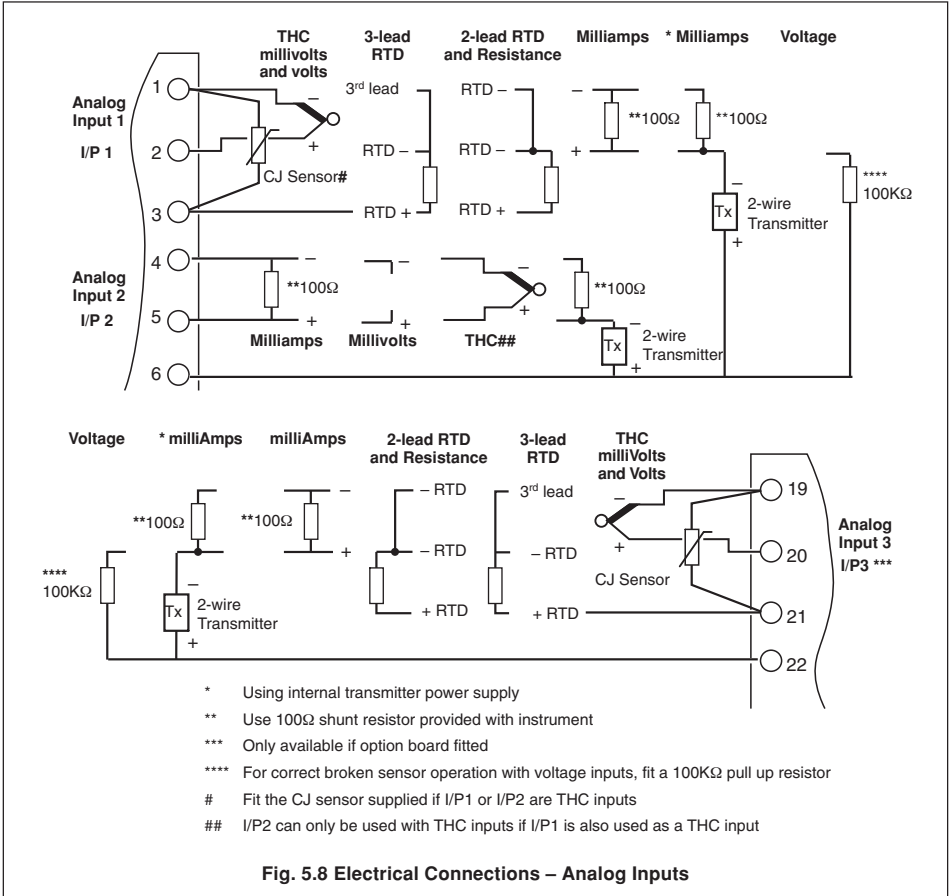

Fig. 5.7 Electrical Connections – General



...5.2.1 Electrical Connections – Figs. 5.7 to 5.9





### 5.3 Relays

**Note.** Refer to the Rear Fold-out/ Table B – Output Sources for default relay assignments.

Relay contacts are rated at:  
 115/230V a.c. at 5A (non-inductive)  
 250V d.c. 25W max.

### 5.4 Digital Output

15V d.c. min. at 20mA  
 Min. load 667 $\Omega$

### 5.5 Control or Retransmission Analog Output

Max. load 15V (750 $\Omega$  at 20mA).  
 Isolated from analog input, dielectric strength  
 500V for 1 minute.

#### 5.3.1 Setting the Relay Links – Fig. 5.10

Set the links on the processor board and the option board (if fitted).

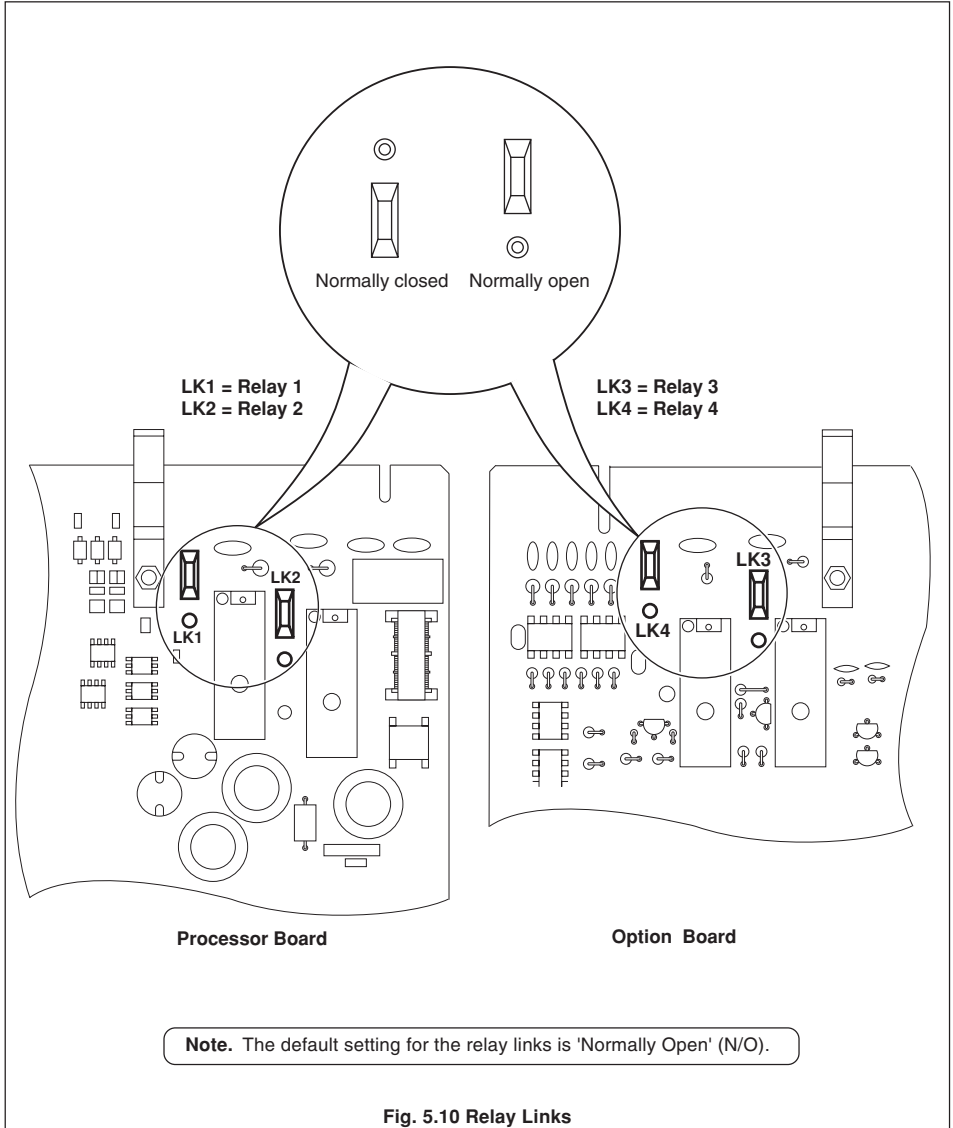
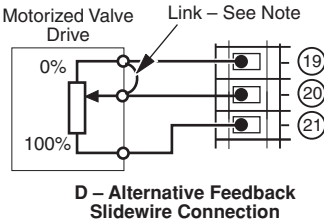
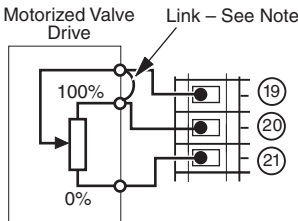
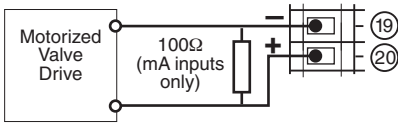
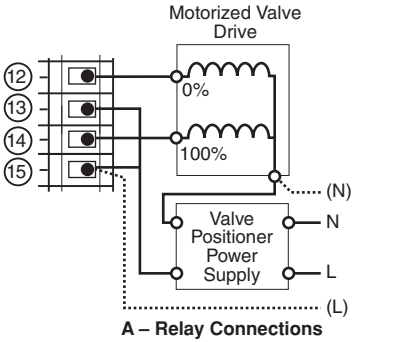

Fig. 5.10 Relay Links



### 5.6 Motorized Valve Connections – Fig. 5.11

**Note.** Relays used to drive the motorized valve must be set for 'Normally Open' operation – see Section 5.3.1.



**Note.** The wire link must be connected at the motorized valve end, NOT to the instrument terminals.

Fig. 5.11 Motorized Valve Connections

### 5.7 Input Connections

Make connections to each input – see Fig 5.8.

**Refer to Table A on the rear fold-out for the default input assignment settings.**

#### 5.7.1 Thermocouple (THC) Inputs

**Note.** Use the correct compensating cable between the THC and the terminals – see Table 5.1.

Automatic Cold Junction Compensation (ACJC) is incorporated by use of CJ sensors wired across the input terminals of I/P1 and I/P3 – see Fig. 5.12.

Alternatively, the CJ sensor can be mounted remotely at the point where the thermocouple cable terminates into copper cable, e.g. where cables enter an instrument panel – see Fig. 5.13.

It is possible to use an external fixed cold (reference) junction, if the instrument is programmed for use with millivolt inputs and the appropriate thermocouple linearizer is selected. This is only possible via the PC configurator.

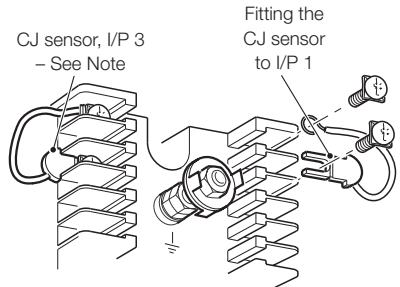

**Note.** Only fit a CJ sensor to I/P 3 if the option board is also fitted.

Fig. 5.12 CJ Sensor – Connections

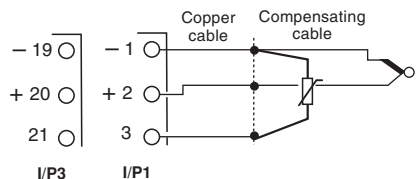

Fig. 5.13 Remote-mounted CJ Sensor – Connections



### 5.7.2 3-lead Resistance Thermometer (RTD) Inputs

The three leads must have equal resistance, not exceeding  $50\Omega$  each.

### 5.7.3 2-lead Resistance Thermometer (RTD) Inputs

If long leads are necessary it is preferable to use a 3-lead RTD. If the RTD is to be used in a hazardous area, a 3-lead RTD connected via a suitable Zener barrier, must be used.

### 5.8 Output Connections

Make connections as shown in Fig. 5.7.

*Refer to Table B on the rear fold-out for the default output assignment settings.*

### 5.9 Power Supply Connections



#### Warning.

- A fuse (315mA Type T) must be fitted in the live (+ve) supply line.
- The ground line must be connected to the earth (ground) stud and not to terminal 18 on the terminal block – see Fig. 5.7.  
Do not disturb the link between terminal 18 and the ground stud.
- The type of power supply required (a.c. or d.c.) is stated at the time of order and can be identified from the instrument code number:
  - C50X/XX0X/STD = 85V min. to 265V max. a.c.
  - C50X/XX1X/STD = 24V d.c.

Type of Thermocouple	Compensating Cable											
	BS1843			ANSI MC 96.1			DIN 43714			BS4937 Part No.30		
	+	-	Case	+	-	Case	+	-	Case	+	-	Case
Ni-Cr/Ni-Al (K)	Brown	Blue	Red	Yellow	Red	Yellow	Red	Green	Green	Green	White	Green *
Nicrisil/Nisil (N)	Orange	Blue	Orange	Orange	Red	Orange	—			Pink	White	Pink *
Pt/Pt-Rh (R and S)	White	Blue	Green	Black	Red	Green	Red	White	White	Orange	White	Orange *
Pt-Rh/Pt-Rh (B)	—			—			—			Grey	White	Grey *
Cu/Cu-Ni (T)	White	Blue	Blue	Blue	Red	Blue	Red	Brown	Brown	Brown	White	Brown *
Fe/Con (J)	Yellow	Blue	Black	White	Red	Black	Red	Blue	Blue	Black	White	Black *
* Case Blue for intrinsically safe circuits												
Fe/Con (L) (DIN 43710)	—			—			DIN 43710			—		
							Blue/red	Blue	Blue			

Table 5.1 Thermocouple Compensating Cable

# SPECIFICATION

## Summary

8 application templates: Single loop, Auto/Manual, Analog backup, Indicator

Two Autotune options

Control Efficiency Monitor

PC configuration

IP66/NEMA4X front face

## Operation

### Display

2 x 100mm 40-segment LED bargraphs

2 x 10mm 4-digit LED indicators

1 x 10mm 3-digit LED indicators

Display range -1999 to +9999

### Configuration

Basic configuration via front panel keys

Advanced feature configuration by PC only

### Security

Internal security switch and password-protected menus

## Standard Functions

### Control Strategies

Single-loop, Auto/manual Station, Analog Backup, Indicator/Manual Loader

### Output Types

Current proportioning, Time proportioning, On/off, Motorized valve (with and without feedback), Heat/cool.

### Control Parameters

Four sets of PID settings, selectable via digital signals

### Set Points

Local, remote and four local fixed set points, selectable via digital signals

### Configured Outputs

Three preset output values, selectable via digital signals

### Autotune

On demand for 1/4 wave or minimal overshoot

## Analog Inputs

### Universal Process Inputs

#### Number

1 standard

1 optional

#### Type

Universally configurable to provide:

- Thermocouple (THC)
- Resistance thermometer (RTD)
- mV
- Volts
- mA
- Resistance

#### Input Impedance

mA	100Ω
mV, V	10MΩ

#### Linearizer Functions

THC types B, E, J, K, L, N, R, S, T, PT100,  $\sqrt{\quad}$ ,  $^{3/2}$ ,  $^{5/2}$

#### Broken Sensor Protection

Programmable for upscale or downscale drive

#### Sample Interval

125ms (1 input)

#### Digital filter

Programmable

#### Cold Junction Compensation

Automatic CJC incorporated as standard

Stability 0.05°C change in ambient temperature

#### Input Protection

Common mode rejection	>120dB at 50/60Hz with 300Ω imbalance resistance
Series mode rejection	>60dB at 50/60Hz

#### Transmitter Power Supply

Number	1 standard, 1 optional
Voltage	24V DC nominal
Drive	Up to 45mA as standard, up to 23mA on option board

## Non-universal Process Input

#### Number

1 standard

#### Input types

mA, mV only (THC only if IP1 is also THC)

Linearization B, E, J, K, L, N, R, S, T,  $\sqrt{\quad}$ ,  $^{3/2}$ ,  $^{5/2}$

**EMC**

**Emissions and Immunity**

Meets requirements of IEC 61326 for an Industrial Environment

**Outputs**

**Control/Retransmission Outputs**

Number 1 standard, 1 optional  
 Type Programmable as analog or logic (digital) output  
 Isolation Galvanically isolated from the rest of the circuitry  
 Analog range 0 and 20mA (programmable), accuracy: 0.25%  
 Digital voltage 17V @ 20mA

**Relay Outputs**

Number 2 standard, 2 optional  
 Type SPST, rated 5A at 115/230V AC

**Digital Inputs**

Number 2 standard, 2 optional  
 Type Volt-free  
 Minimum pulse 200ms

**Advanced Features**

**Maths Blocks \***

Number 4  
 Operators +, -, x, /, Average, Maximum, Minimum, High select, Low select, v, Median select, Relative Humidity  
 Input multiplexer (digitally selected)

**Delay Timers \***

Number 2  
 Programmable Delay and Duration in seconds

**Logic Equations \***

Number 6  
 Elements 15 per equation  
 Operators OR, AND, NOR, NAND, NOT, EXOR

**Custom Linearizers \***

Number 2  
 Breakpoints 15 per linearizer

\* Accessed via PC Configurator

**Standard Analog Input Ranges**

Thermocouple	Maximum Range °C	Maximum Range °F	Accuracy (% of reading)
B	-18 to 1800	0 to 3270	0.1% or ±1°C (1.8°F) [above 200°C (392°F)] *
E	-100 to 900	-140 to 1650	0.1% or ±0.5°C (0.9°F)
J	-100 to 900	-140 to 1650	0.1% or ±0.5°C (0.9°F)
K	-100 to 1300	-140 to 2350	0.1% or ±0.5°C (0.9°F)
L	-100 to 900	-140 to 1650	0.1% or ±1.5°C (2.7°F)
N	-200 to 1300	-325 to 2350	0.1% or ±0.5°C (0.9°F)
R	-18 to 1700	0 to 3000	0.1% or ±0.5°C (0.9°F) [above 300°C (540°F)] *
S	-18 to 1700	0 to 3000	0.1% or ±0.5°C (0.9°F) [above 200°C (392°F)] *
T	-250 to 300	-400 to 550	0.1% or ±0.5°C (0.9°F)

\* For B, R and S thermocouples, accuracy is not guaranteed below value stated

Min. span below zero Type T 70°C (126°F) Type N 105°C (189°F) THC standards DIN 43710 IEC 584

RTD	Maximum Range °C	Maximum Range °F	Accuracy (% of reading)**
Pt100	-200 to 600	-325 to 1100	0.1% or ±0.5°C (0.9°F)

\*\* RTD, 3-wire platinum, 100Ω per DIN 43760 standard (IEC 751), with range of 0 to 400Ω

Linear Inputs	Range	Accuracy (% of reading)
Millivolts	0 to 500mV	0.1% or ±10µA
Milliamps	0 to 50mA	0.2% or ±2µA
Volts	0 to 5V	0.2% or ±2mV
Resistance	0 to 5000Ω	0.2% or ±0.08Ω

---

## ...SPECIFICATION

---

### Options

#### Analog Inputs

Number	1
Isolation	Galvanically isolated from the rest of the circuitry
Type	Universal (see above)

#### Analog/Digital output

Number	1
Isolation	Galvanically isolated from the rest of the circuitry
Type	Programmable 0 to 20mA analog or 17V @ 20mA digital

#### Relay Outputs

Number	2
Type	SPST, rated 5A at 115/230V AC

#### Digital Inputs

Number	2
Type	Volt-free
Minimum pulse	200ms

#### Serial Communications

Connections	RS485, 2- or 4-wire
Protocol	Modbus RTU
Isolation	Galvanically isolated from the rest of the circuitry

---

### Physical

#### Size

76mm x 148mm x 149.5mm  
(2.99 in. x 5.83 in. x 5.87 in.)

#### Weight

750g (1.6lb)

### Electrical

#### Voltage

85 to 265V AC 50/60Hz  
24V DC

#### Power consumption

<10VA

#### Power interruption protection

Up to 60ms

#### Safety

General safety EN 61010-1

#### Dielectric Strength

500V DC to earth  
Analog/digital output 1 to rest of the circuitry  
(500V DC for 1 minute)  
Analog/digital output 2 to rest of the circuitry  
(500V DC for 1 minute)  
Analog input 3 (IP3) to rest of the circuitry  
(500V DC for 1 minute)  
Serial communications to rest of the circuitry  
(500V DC for 1 minute)

---

### Environmental

#### Operating Limits

0°C to 55°C (32°F to 130°F)  
5 to 95%RH (non-condensing)

#### Temperature stability

<0.02%/°C or 2µV/°C (<0.011%/°F or 1.11µV/°F)  
Long term drift <0.02% of reading or 20µV annually

#### Front face

NEMA4X (IP66)



A1 Single Loop Controller (Templates 1 and 2)

**Single Loop Control** provides basic feedback control using three term PID or On/off control. The controller output is calculated from the difference between the process variable and the control set point. The control set point can be a fixed value entered by the user or from a remote source.

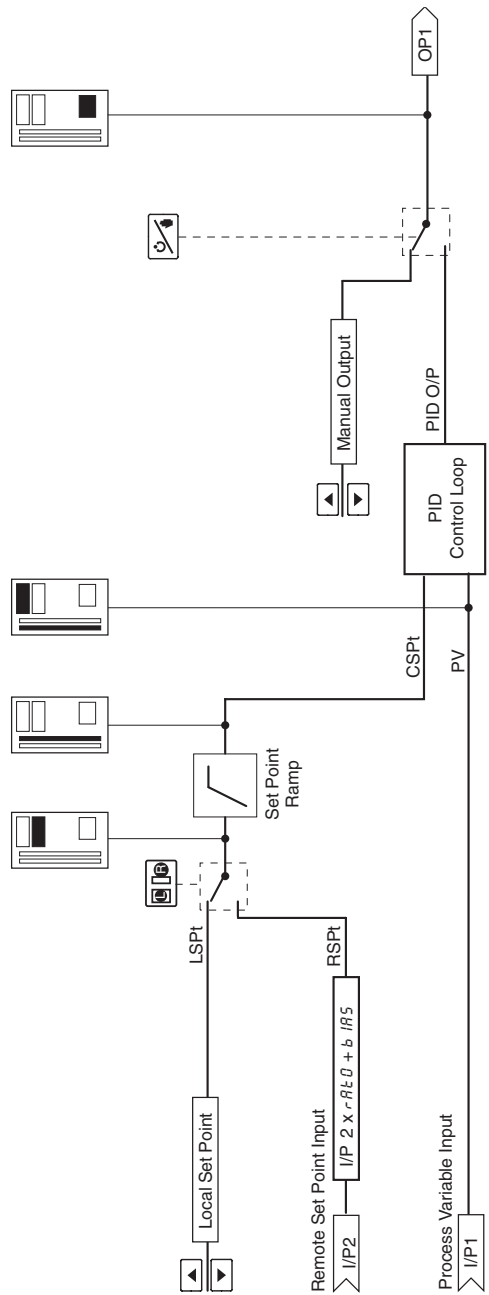

•1

•1 Template 2 Only

**A2 Auto/Manual Station and Analog Backup Station**

**A2.1 Series and Parallel Operation**

**Note.** See Sections A2.2 and A2.3 for detailed templates.

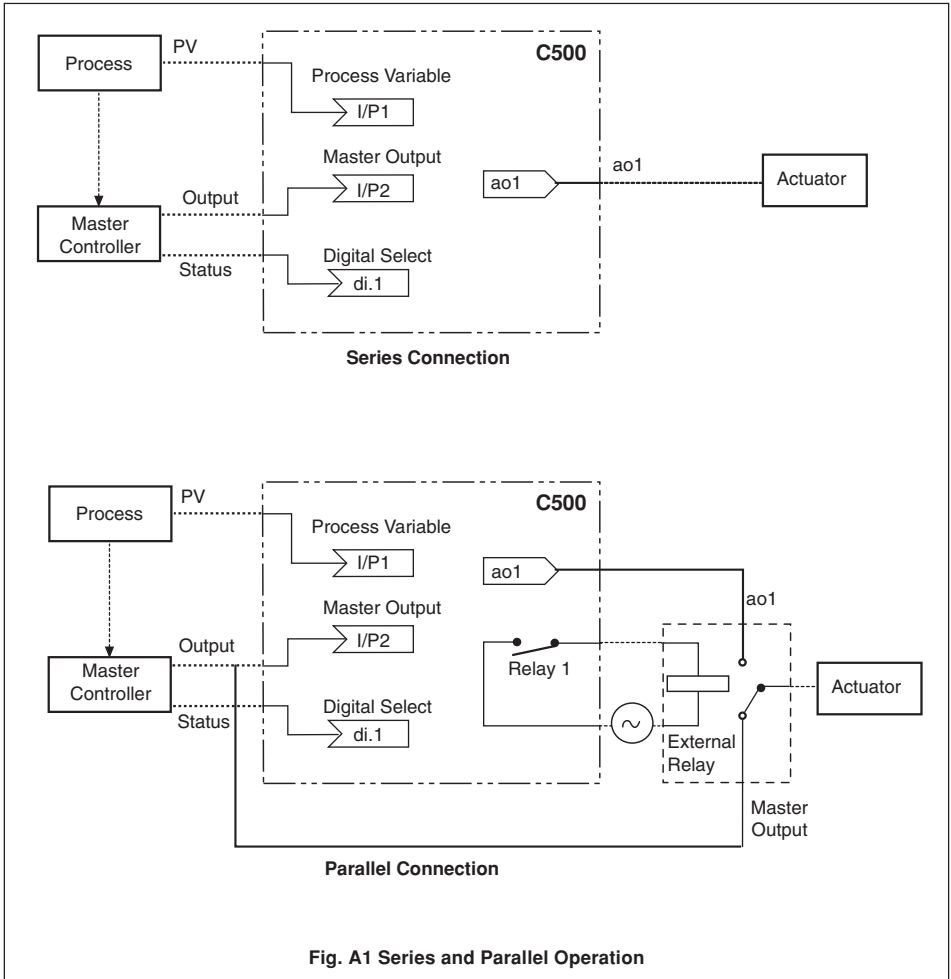



...A2.2 Auto/Manual Station (Templates 3 and 4)

The **Auto/manual Station** provides a backup for a Master controller. In normal operation the COMMANDER 500's current output follows the master controller's output value. A fault in the master system can be identified either by detecting a low signal on the master output (template 3) or via a digital signal (template 4). When a fault is detected the COMMANDER 500 selects manual mode with its output either set to the last valid master output value or to a configured output value – see Section 4.6/ Control Configuration/ Configured Output 1. When the master signal is restored or the digital input returns to its normal state the COMMANDER 500 switches back to auto mode (i.e. COMMANDER 500 output = master output).

The auto/manual station can be used in series or in parallel with the master output signal – see Fig. A1. Parallel operation is achieved by using relay 1 in the COMMANDER 500 to energize an external relay (with suitable changeover contacts for switching low level signals) which selects the output to be routed to the actuator.

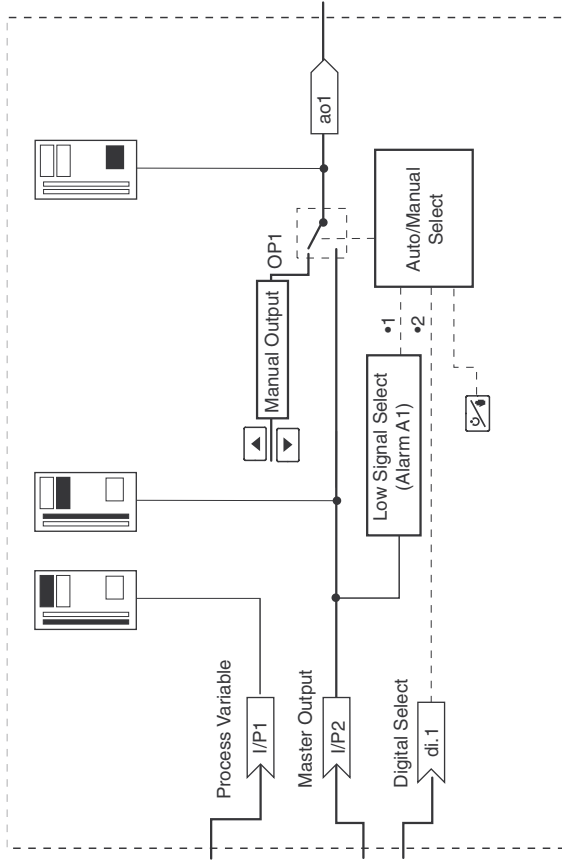

•1 Template 3 only, Alarm A1 trip value can be set to give the desired low signal detection

•2 Template 4 only

A2.3 Analog Backup (Templates 5 and 6)

The **Analog Backup** provides a backup for a master controller. In normal operation (remote control mode selected) the COMMANDER 500's current output follows the master controller's output value. A fault in the master system can be identified either by detecting a low signal on the master output (template 5) or via a digital signal (template 6). When a fault is detected the COMMANDER 500 switches into local control mode and the process is controlled by the PID output of the COMMANDER 500. The COMMANDER 500 PID algorithm continually tracks the master output value to ensure bumpless transfer from remote to local mode operation. When the master signal is restored or the digital input returns to its normal state the COMMANDER 500 switches back to remote control mode (i.e. COMMANDER 500 output = master output).

The analog backup station can be used in series or in parallel with the master output signal. (See Fig. A1). Parallel operation is achieved by using relay 1 in the COMMANDER 500 to energize an external relay (with suitable changeover contacts for switching low level signals) which selects the output to be routed to the actuator.

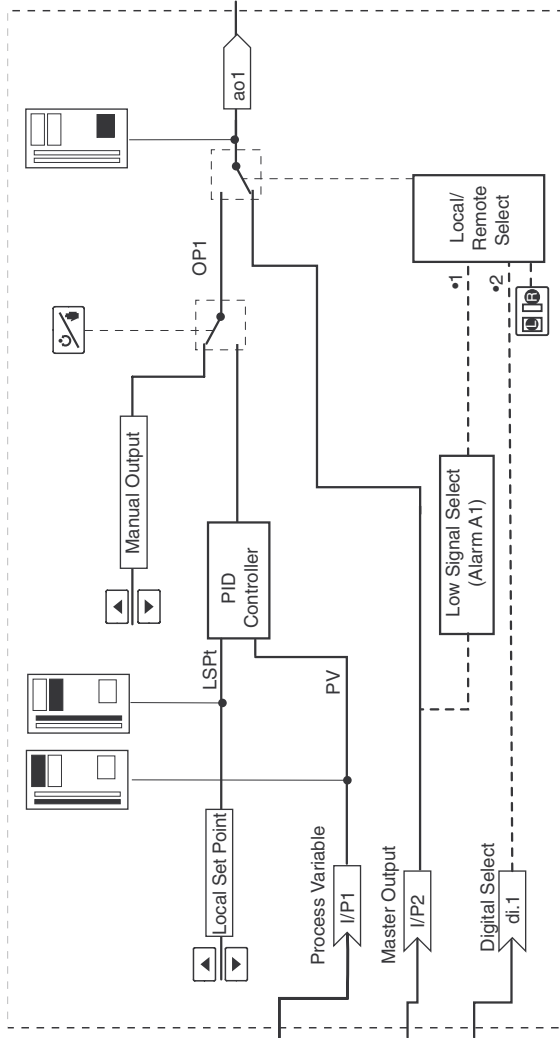

**A3 Indicator/Manual Loader Station (Templates 7 and 8)**

The **Indicator/manual Loader Station** is used to display one or two process variables on the digital and bargraph displays. If the control output is assigned to an analog output, the lower display indicates its value which can be adjusted by the user. This output can be used to manually control a process or to provide a set point value for another controller.

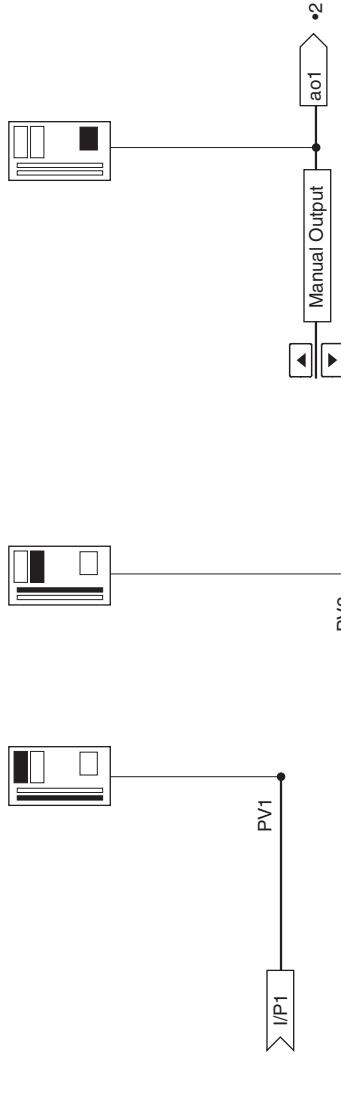

•1 Template 8 Only

•2 Not applicable if Control Output Type is set to 'None' – see Section 4.2/Basic Configuration.

### B1 Introduction

Using the COMMANDER Configurator the COMMANDER 500 can be programmed without using any of the front panel keys.

In addition to the standard settings, the Configurator also gives access to more advanced features not accessible via the front panel keys. These are summarized below.

For information on using individual features, refer to the on-line help facility.

**Note.** The instrument must be in Configuration Mode (Level 6 or above) and Modbus serial communications must be disabled when uploading or downloading from the PC Configurator.

### B2 Analog Input Customization

- Custom mA, mV, Voltage and Resistance ranges
- Standard Linearizers can be assigned to electrical inputs (eg. allowing transmitter inputs to have thermocouple or resistance linearizers to be applied)
- Programmable fault detection levels (default = 10%)

### B3 Four Programmable Maths Blocks

One of seven types can be assigned to each maths block:

<b>Standard Arithmetic</b>	Up to 4 operands and 3 operators can be combined in each block, with the operands being calculated sequentially.  Operators: add, subtract, divide, multiply, high select, low select, median select  Operands: any analog or digital signals (digital signals have the value '1' or '0')
<b>Average</b>	The average value of an analog signal over a selectable time period, reset by digital signal
<b>Maximum detection</b>	The maximum value of an analog signal, reset by digital signal
<b>Minimum detection</b>	The minimum value of an analog signal, reset by digital signal
<b>Relative humidity</b>	Calculated from wet and dry bulb temperature sensors
<b>Square root</b>	The square root value of any analog signal
<b>Input multiplexer</b>	Selection of one or two analog variables using a digital signal

### B4 Six Logic Equations

<b>Elements</b>	Up to 15 per equation
<b>Operators</b>	Up to 7 per equation: OR, AND, NOR, NAND, NOT, EXOR
<b>Operands</b>	Up to 8 per equation: any digital signal. The NOT operator can be used to invert digital signals.

### B5 Process Alarm Customization

- Time Hysteresis, 0 to 9999 seconds
- Alarm Disable Source

### B6 Two Real Time Alarms

- Programmable ON days, hours, minutes and duration (00:00 to 23:59)
- Wildcard (\*) to allow operation every .x minutes past the hour

### B7 Two Delay Timers

- Programmable delay and duration (0 to 9999 seconds)

## B8 Two Custom Linearizers

- 15 breakpoints per linearizer
- The source can be any analog signal

## B9 Template Customization

Each template can be customized by changing the sources for various functions in the COMMANDER 500. This allows maths blocks and custom linearizers to be added into the standard template format.

The following sources can be programmed:

- process variable inputs
- set point inputs
- position feedback input
- input to ratio/bias block
- ratio inputs
- bias inputs

## B10 Connecting the COMMANDER PC Configurator

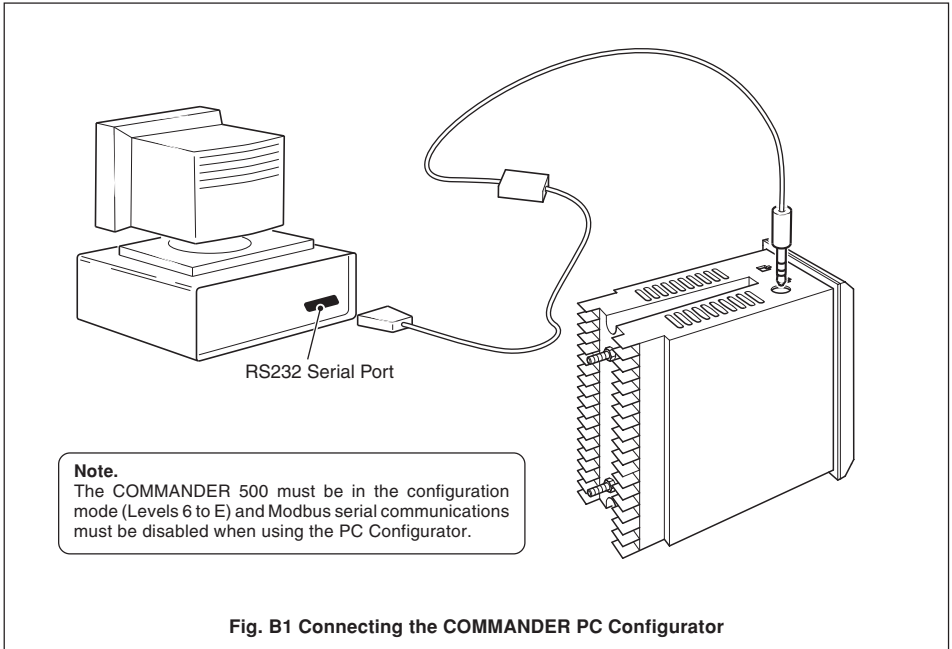

**Set Up Frames**

<i>Frame Title</i>	<i>Mnemonic</i>	<i>Number</i>
<b>A</b>		
Alarm 1 Trip	<i>1xxx</i>	<i>4.01</i>
Alarm 2 Trip	<i>2xxx</i>	<i>4.02</i>
Alarm 3 Trip	<i>3xxx</i>	<i>4.03</i>
Alarm 4 Trip	<i>4xxx</i>	<i>4.04</i>
Alarm 5 Trip	<i>5xxx</i>	<i>4.05</i>
Alarm 6 Trip	<i>6xxx</i>	<i>4.06</i>
Alarm 7 Trip	<i>7xxx</i>	<i>4.07</i>
Alarm 8 Trip	<i>8xxx</i>	<i>4.08</i>
<b>B</b>		
Approach Band 1	<i>Rb 1</i>	<i>2.15</i>
<b>C</b>		
Control Zone Deadband	<i>SSPt</i>	<i>2.21</i>
Cycle Time 1	<i>CYC 1</i>	<i>2.01</i>
Cycle Time 2	<i>CYC 2</i>	<i>2.02</i>
<b>D</b>		
Deadband (Feedback only)	<i>dbnd</i>	<i>5.03</i>
Derivative Action Time 1	<i>drU 1</i>	<i>2.13</i>
<b>H</b>		
Heat/Cool Output 1 Start	<i>Y 1St</i>	<i>2.22</i>
Heat/Cool Output 2 Start	<i>Y 2St</i>	<i>2.23</i>
<b>I</b>		
Integral Action Time 1	<i>IRt. 1</i>	<i>2.01</i>
Integral Action Time 2	<i>IRt. 2</i>	<i>2.10</i>
Integral Action Time 3	<i>IRt. 3</i>	<i>2.11</i>
Integral Action Time 4	<i>IRt. 4</i>	<i>2.12</i>
<b>L</b>		
Local Set Point 1	<i>LSP. 1</i>	<i>3.01</i>
Local Set Point 2	<i>LSP. 2</i>	<i>3.02</i>
Local Set Point 3	<i>LSP. 3</i>	<i>3.03</i>
Local Set Point 4	<i>LSP. 4</i>	<i>3.04</i>
<b>M</b>		
Manual Reset	<i>rSt. 1</i>	<i>2.17</i>
Motorised Valve Bias	<i>Ub IR</i>	<i>5.02</i>
Motorised Valve Ratio	<i>Ur Rt</i>	<i>5.01</i>
<b>O</b>		
Output 1 On/off Hysteresis Value	<i>HYS. 1</i>	<i>2.03</i>
Output 2 On/off Hysteresis Value	<i>HYS. 2</i>	<i>2.04</i>

<b>P</b>		
Proportional Band 1	<i>Pb - 1</i>	<i>2.05</i>
Proportional Band 2	<i>Pb - 2</i>	<i>2.06</i>
Proportional Band 3	<i>Pb - 3</i>	<i>2.07</i>
Proportional Band 4	<i>Pb - 4</i>	<i>2.08</i>
<b>R</b>		
Ramp Rate	<i>r.r tE</i>	<i>3.10</i>
Regulator Travel Time	<i>r.t r.U.</i>	<i>5.04</i>
Remote Set Point Bias	<i>b IR5</i>	<i>3.07</i>
Remote Set Point Ratio	<i>r Rt 0</i>	<i>3.06</i>
<b>S</b>		
Set Points	<i>LEU3</i>	<i>3.00</i>
<b>T</b>		
Tune	<i>LEU2</i>	<i>2.00</i>
<b>V</b>		
Valve Set Up	<i>LEU5</i>	<i>5.00</i>

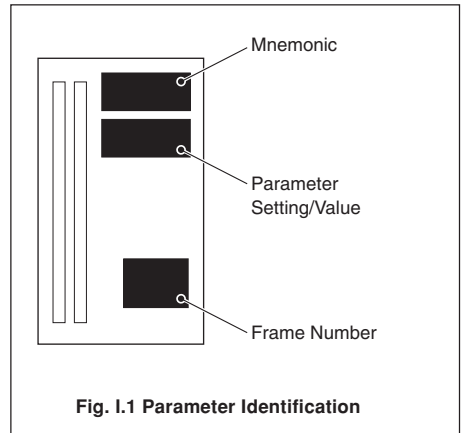

**Fig. I.1 Parameter Identification**



**Configuration Frames**

<i>Frame Title</i>	<i>Mnemonic</i>	<i>Number</i>
<b>A</b>		
Alarm 1 Hysteresis	<i>HYS.1</i>	<i>8.03</i>
Alarm 1 Trip	<i>LRP.1</i>	<i>8.02</i>
Alarm 1 Type	<i>LYP.1</i>	<i>8.01</i>
Alarm 2 Hysteresis	<i>HYS.2</i>	<i>8.06</i>
Alarm 2 Trip	<i>LRP.2</i>	<i>8.05</i>
Alarm 2 Type	<i>LYP.2</i>	<i>8.04</i>
Alarm 3 Hysteresis	<i>HYS.3</i>	<i>8.09</i>
Alarm 3 Trip	<i>LRP.3</i>	<i>8.08</i>
Alarm 3 Type	<i>LYP.3</i>	<i>8.07</i>
Alarm 4 Hysteresis	<i>HYS.4</i>	<i>8.12</i>
Alarm 4 Trip	<i>LRP.4</i>	<i>8.11</i>
Alarm 4 Type	<i>LYP.4</i>	<i>8.10</i>
Alarm 5 Hysteresis	<i>HYS.5</i>	<i>8.15</i>
Alarm 5 Trip	<i>LRP.5</i>	<i>8.14</i>
Alarm 5 Type	<i>LYP.5</i>	<i>8.13</i>
Alarm 6 Hysteresis	<i>HYS.6</i>	<i>8.18</i>
Alarm 6 Trip	<i>LRP.6</i>	<i>8.17</i>
Alarm 6 Type	<i>LYP.6</i>	<i>8.16</i>
Alarm 7 Hysteresis	<i>HYS.7</i>	<i>8.21</i>
Alarm 7 Trip	<i>LRP.7</i>	<i>8.20</i>
Alarm 7 Type	<i>LYP.7</i>	<i>8.19</i>
Alarm 8 Hysteresis	<i>HYS.8</i>	<i>8.24</i>
Alarm 8 Trip	<i>LRP.8</i>	<i>8.23</i>
Alarm 8 Type	<i>LYP.8</i>	<i>8.22</i>
Alarm Acknowledge Enable	<i>FPRP.</i>	<i>b.03</i>
Alarm Configuration	<i>LEUB, RL - 5</i>	<i>8.00</i>
Analog I/P 1 Offset Cal	<i>OFF.1</i>	<i>E.01</i>
Analog I/P 1 Span Cal	<i>SPN.1</i>	<i>E.02</i>
Analog I/P 2 Offset Cal	<i>OFF.2</i>	<i>E.03</i>
Analog I/P 2 Span Cal	<i>SPN.2</i>	<i>E.04</i>
Analog I/P 3 Offset Cal	<i>OFF.3</i>	<i>E.05</i>
Analog I/P 3 Span Cal	<i>SPN.3</i>	<i>E.06</i>
Analog O/P 1 Electrical High	<i>EN1H</i>	<i>C.03</i>
Analog O/P 1 Electrical Low	<i>EN1L</i>	<i>C.04</i>
Analog O/P 1 Engineering High	<i>r1H</i>	<i>C.05</i>
Analog O/P 1 Engineering Low	<i>r1L</i>	<i>C.06</i>
Analog O/P 2 Electrical High	<i>EN2H</i>	<i>C.11</i>
Analog O/P 2 Electrical Low	<i>EN2L</i>	<i>C.12</i>
Analog O/P 2 Engineering High	<i>r2H</i>	<i>C.13</i>
Analog O/P 2 Engineering Low	<i>r2L</i>	<i>C.14</i>
Analog Output 1 Source	<i>EN1R</i>	<i>C.02</i>
Analog Output 2 Source	<i>EN2R</i>	<i>C.10</i>
Analog/Dig Output 1 Type	<i>LYP.1</i>	<i>C.01</i>
Analog/Dig Output 2 Type	<i>LYP.2</i>	<i>C.09</i>
Auto Selection Source	<i>RS-C</i>	<i>R.18</i>
Auto/Manual Switch Enable	<i>FPR.</i>	<i>b.01</i>
Autotune Password	<i>RPR5</i>	<i>b.07</i>

<b>B</b>		
Basic Configuration	<i>LEUB, RPPL</i>	<i>6.00</i>
Bias Display Enable	<i>bd15</i>	<i>b.06</i>
<b>C</b>		
Calibration	<i>LEUE, CRL</i>	<i>E.00</i>
CJ Beta Value	<i>bEER</i>	<i>E.14</i>
CJ Reading - I/P1 & I/P2	<i>CJ 1</i>	<i>E.15</i>
CJ Reading - I/P3	<i>CJ 2</i>	<i>E.16</i>
CJ Reference Value	<i>rEF</i>	<i>E.13</i>
Configuration Password	<i>CPR5</i>	<i>b.09</i>
Configured Output 1	<i>COP.1</i>	<i>R.13</i>
Configured Output 2	<i>COP.2</i>	<i>R.15</i>
Configured Output 3	<i>COP.3</i>	<i>R.17</i>
Control Action	<i>CRCt</i>	<i>6.03</i>
Control Configuration	<i>LEUR</i>	<i>R.00</i>
<b>D</b>		
Day Setting	<i>dRY</i>	<i>b.10</i>
Digital Output 1 Polarity	<i>dG1P</i>	<i>C.08</i>
Digital Output 1 Source	<i>dG1R</i>	<i>C.07</i>
Digital Output 2 Polarity	<i>dG2P</i>	<i>C.16</i>
Digital Output 2 Source	<i>dG2R</i>	<i>C.15</i>
<b>F</b>		
Feedback Range High	<i>FbH1</i>	<i>E.12</i>
Feedback Range Low	<i>FbL0</i>	<i>E.11</i>
<b>I</b>		
Input 1 Broken Sensor	<i>b5d.1</i>	<i>7.06</i>
Input 1 Decimal Point	<i>dP.1</i>	<i>7.03</i>
Input 1 Engineering High	<i>EN1H</i>	<i>7.04</i>
Input 1 Engineering Low	<i>EN1L</i>	<i>7.05</i>
Input 1 Filter Time Constant	<i>FLt.1</i>	<i>7.07</i>
Input 1 Temp Units	<i>UNt.1</i>	<i>7.02</i>
Input 1 Type	<i>LYP.1</i>	<i>7.01</i>
Input 2 Broken Sensor	<i>b5d.2</i>	<i>7.13</i>
Input 2 Decimal Point	<i>dP.2</i>	<i>7.10</i>
Input 2 Engineering High	<i>EN2H</i>	<i>7.11</i>
Input 2 Engineering Low	<i>EN2L</i>	<i>7.12</i>
Input 2 Filter Time Constant	<i>FLt.2</i>	<i>7.14</i>
Input 2 Temp Units	<i>UNt.2</i>	<i>7.09</i>
Input 2 Type	<i>LYP.2</i>	<i>7.08</i>
Input 3 Broken Sensor	<i>b5d.3</i>	<i>7.20</i>
Input 3 Decimal Point	<i>dP.3</i>	<i>7.17</i>
Input 3 Engineering High	<i>EN3H</i>	<i>7.18</i>
Input 3 Engineering Low	<i>EN3L</i>	<i>7.19</i>
Input 3 Filter Time Constant	<i>FLt.3</i>	<i>7.21</i>
Input 3 Temp Units	<i>UNt.3</i>	<i>7.16</i>
Input 3 Type	<i>LYP.3</i>	<i>7.15</i>

## ...FRAMES INDEX

### L

Level Heading	<i>LEU7</i>	<i>7.00</i>
Local Set Point Source	<i>LC5r</i>	<i>9.13</i>
Local/Remote Enable	<i>FPLr</i>	<i>b.02</i>
Local/Remote Set Point Source	<i>Lr5r</i>	<i>9.12</i>

### M

MV Calibration selection	<i>FCRL</i>	<i>E.07</i>
MV Feedback – closed	<i>CCRL</i>	<i>E.09</i>
MV Feedback – open	<i>OCRL</i>	<i>E.10</i>
Mains Rejection	<i>FrEJ</i>	<i>G.06</i>
Man/Auto Selection Source	<i>R_5r</i>	<i>R.15</i>
Manual 1 Selection Source	<i>_5r1</i>	<i>R.12</i>
Manual 2 Selection Source	<i>_5r2</i>	<i>R.14</i>

MODBUS Address	<i>Raddr</i>	<i>d.03</i>
MODBUS Parity	<i>Prty</i>	<i>d.02</i>

### O

O/P Low Limit	<i>OPLD</i>	<i>R.06</i>
O/P High Limit	<i>OPH1</i>	<i>R.05</i>
OP 1 High Limit	<i>OP1H</i>	<i>R.07</i>
OP 2 High Limit	<i>OP2H</i>	<i>R.08</i>
OP 2 Low Limit	<i>OP2L</i>	<i>R.09</i>
Operator Configuration	<i>LEUb, OPEr</i>	<i>b.00</i>

Output Assignment	<i>LEUC, ASSn</i>	<i>C.00</i>
Output Slew Rate	<i>OPSr</i>	<i>R.10</i>
Output Slew Rate Disable	<i>Srd5</i>	<i>R.11</i>
Output Type	<i>QtYP</i>	<i>G.02</i>

### P

Power Fail Recovery Mode	<i>PrEC</i>	<i>R.01</i>
Power Fail Recovery Time	<i>rECt</i>	<i>R.02</i>
Process Variable Fail Action	<i>PUFR</i>	<i>R.03</i>
PV Fail Default Output	<i>dFDP</i>	<i>R.04</i>

### R

Ratio Display Enable	<i>r.d15</i>	<i>b.05</i>
Regulator Travel Time	<i>r.t.r.U.</i>	<i>E.08</i>
Relay 1 Polarity	<i>rL1P</i>	<i>C.18</i>
Relay 1 Source	<i>rL1R</i>	<i>C.17</i>
Relay 2 Polarity	<i>rL2P</i>	<i>C.20</i>
Relay 2 Source	<i>rL2R</i>	<i>C.19</i>

Relay 3 Polarity	<i>rL3P</i>	<i>C.22</i>
Relay 3 Source	<i>rL3R</i>	<i>C.21</i>
Relay 4 Polarity	<i>rL4P</i>	<i>C.24</i>
Relay 4 Source	<i>rL4R</i>	<i>C.23</i>
Remote Set Point Source	<i>r5rC</i>	<i>9.14</i>
RSPT Fault Action	<i>SPFR</i>	<i>9.06</i>

### S

Serial Communications	<i>LEUd</i>	<i>d.00</i>
Serial Configuration	<i>SCFG</i>	<i>d.01</i>
Set Point Configuration	<i>LEU9, SEtP</i>	<i>9.00</i>
Set Point 1 Source	<i>L5r.1</i>	<i>9.08</i>
Set Point 2 Source	<i>L5r.2</i>	<i>9.09</i>
Set Point 3 Source	<i>L5r.3</i>	<i>9.10</i>
Set Point 4 Source	<i>L5r.4</i>	<i>9.11</i>

Set Point Default Value	<i>dF5P</i>	<i>9.07</i>
Set Point High Limit	<i>SPtH</i>	<i>9.02</i>
Set Point Low Limit	<i>SPtL</i>	<i>9.03</i>
Set Point Tracking	<i>t.r.CP.</i>	<i>9.01</i>

Set up Password	<i>SPAS</i>	<i>b.08</i>
Set Point Adjust Disable	<i>SRdJ</i>	<i>b.04</i>

### T

Template Applications	<i>t.RPP</i>	<i>G.01</i>
Time Display	<i>t.CLP.</i>	<i>b.13</i>
Tune Select Source 1	<i>t15r</i>	<i>R.19</i>
Tune Select Source 2	<i>t25r</i>	<i>R.20</i>
Tune Select Source 3	<i>t35r</i>	<i>R.21</i>
Tune Select Source 4	<i>t45r</i>	<i>R.22</i>

**A**

- Accessories ..... 1
- Alarms ..... 34, 47
  - Acknowledge ..... 5
  - Acknowledge enable ..... 59
  - Configuration ..... 47
  - Hysteresis ..... 49, 50
  - Set Up ..... 34
  - Trip Settings ..... 34, 47
  - Type ..... 34, 49
- Analog Backup Station ..... 16, 84
- Analog Inputs – Level 7 ..... 43
  - Broken Sensor ..... 44, 45, 46
  - Decimal Point ..... 43, 45, 46
  - Engineering Range ..... 44, 45, 46
  - Calibration ..... 68
  - Failure Action ..... 55
- Analog Outputs 1 and 2 ..... 61
  - See Also: Digital Outputs 1 and 2
  - Electrical Ranges ..... 62, 64
  - Engineering Ranges ..... 62, 64
  - Sources ..... 62, 64
    - See Also: Rear Fold-out/ Table D
- Analog Sources ..... Rear Fold-out/ Table D
- Approach Band ..... 30
- Auto-tune ..... 21
  - Error ..... 21
  - Password ..... 60
  - Starting ..... 23
- Auto/Manual
  - Mode Selection Source ..... 56, 57, 58
  - A/M Station Template ..... 14, 74
  - A/M Switch ..... 4, 50

**B**

- Bargraphs ..... 3
  - See Also: Relevant Operator Template in Section 2
- Basic Configuration – Level 6 ..... 39
- Boundless Control – see Motorized Valves
- Broken Sensor Drive ..... 44, 45, 46

**C**

- Calibration – see Analog Inputs
- Calibration Error ..... 9
- Character Set ..... 8
- Clock Settings ..... 60
- Cold Junction
  - Compensation ..... 70, 77, 80
  - Failed ..... 9

**...C**

- Configuration Error ..... 9
- Configuration Password ..... 60
- Configured Outputs 1 to 3 ..... 57
  - See Also: Auto/Manual and Backup Templates
- Control Action ..... 42
- Control Configuration – Level A ..... 54
- Control Efficiency Monitor ..... 24
- Control Set Point – see Set Points
- Control Output Deadband ..... 31
- Custom Linearizer ..... 86

**D**

- Date and Time Setting ..... 60
- Deadband
  - Control Output ..... 31
  - MV Feedback ..... 35
- Default Outputs ..... 52, 55, 57
- Delay Timer ..... 86
- Derivative Action Time ..... 30
- Deviation Alarms ..... 47
- Digital Inputs 1 to 4 ..... 76, 77
  - See Also: Rear Fold-out/ Table C
- Digital Outputs 1 and 2 ..... 61
  - Polarity ..... 61, 63
  - Source ..... 61, 63
- Digital Sources ..... Rear Fold-out/ Table C
- Direct Control Action ..... 42
- Displays ..... 8, 9, 11
  - LCD Alphabet ..... 8

**E**

- Electrical Connections ..... 76
- Error Codes ..... 9

**F**

- Failure Modes
  - Analog Input ..... 55
  - Power Failure ..... 54
  - Process Variable ..... 55
  - Remote Set Point ..... 52
- Fault-finding – see Error Messages
- Fault Detection Level ..... 86
- Feedback (Motorized Valves) ..... 35
  - See Also: Analog Inputs (Process Variable)
- Filter Time Constant ..... 44, 45, 46
- Fine Tuning ..... 25, 68

**G**

- Gain Scheduling
  - Selection ..... 58
  - Sources ..... 58
  - Proportional and Integral Terms ..... 29
- Glossary of Abbreviations ..... 10

**H**

Heat/Cool .....	19
Control Action .....	40, 42
Output limits .....	55
Start positions .....	31
Hysteresis	
Alarms .....	47 to 50
On/off Control .....	28

**I**

Inputs – see Analog Inputs	
Installation .....	71
Integral Action Time .....	29

**K**

Klaxon Alarms .....	47
---------------------	----

**L**

Latch Alarms .....	48
LEDs .....	8
Linearizers .....	43, 45, 46, 86
Line Filter Frequency .....	42
Local Set Point – see Set Points	
Local/Remote Key Enable .....	59
Local/Remote Mode Selection .....	6, 16, 52, 53
Locking Front Panel Keys .....	59
Logic Equations .....	86
Loop Break Monitor .....	10

**M**

Main Rejection Frequency .....	42
Manual Mode Selection .....	56, 57, 59
Pre-set manual output .....	57
Manual Reset .....	30
Maths Blocks .....	86
Mechanical Installation .....	71
MODBUS .....	67, 76
Mounting .....	72
Motorized Valve	
Boundless .....	36
Calibration .....	69
Connections .....	79
Control Type Selection .....	40
Feedback .....	35
Regulator Travel Time .....	35, 37, 69
Set Up .....	35

**O**

On/Off Control .....	28
See Also: Control Types	
Operator Configuration – Level B .....	59
Operating Displays .....	3
Operator Ratio/Bias Display Enable .....	59
Operator Level .....	11

**...O****Output**

Assignment – Level C .....	61
Connections .....	76, 78, 79
Heat/Cool .....	19
Limits .....	55
Slew Rate .....	56
Output Sources	
Types .....	40
Option Board .....	76

**P**

Panel Clamps .....	2, 73
PC Configurator .....	86
PID Parameters .....	29, 30
See Also: Gain Scheduling	
Power Fail Recovery .....	54
Power Supplies .....	76, 80
Power Up Displays .....	11
Process	
Alarms .....	48
Labels .....	75
Optimization – see Control Efficiency Monitor	
Variable – see Analog Inputs	
Proportional Band Settings .....	29, 30

**R**

Ramp Rate (Set Point) .....	33
See Also: Output Slew Rate	
Ratio	
Ratio Display Enable .....	59
Remote Set Point .....	32
Real-time Alarm .....	86
Reference Tables .....	Rear Fold-out
Relative Humidity .....	86
Regulator Travel Time – see Motorized Valves	
Relay	
Connections .....	76
Links .....	78
See Also: Output Assignment, Output Types	
Remote Set Point	
Failure Action .....	52
Scaling .....	32
Selection Source .....	53
Resistance Thermometer .....	43, 46, 76
Retransmission – See Analog Outputs,	
Analog Sources	
Reverse Control Action .....	42

**S**

Secret-til-Lit Indicators .....	8
Security Options .....	60
Serial Communications – Level d .....	67
Set Points	
Configuration – Level 9 .....	51
Default Value .....	52
Limits .....	51
Operator Adjust enable .....	59
Ramp Rate .....	33
Scaling .....	32
Selecting .....	52
Setting – see Relevant Operator Template	
Sources .....	52
Tracking .....	51
Single Loop	
Controllers .....	12, 16, 81, 84
Siting .....	71
Short-cut keys .....	7
Slew Rate .....	56
Soft-start – see Set Point Ramp Rate, Output Slew Rate	
Span Adjustment – see Calibration	

**T**

Temperature Units .....	43, 45, 46
Template Applications .....	11, 39, 81
Rear Fold-out, Table A	
Terminals and Connections .....	76
Thermocouple .....	43, 44, 45, 46, 76
Time	
Setting .....	60
Real-time alarms .....	86
Delay Timers .....	86
Tuning	
Automatic .....	21
Manual .....	25
Tune Parameter Source .....	58

**U**

Units – see Temperature Units

**V**

Valve – see Motorized Valve	
Valve Sticking .....	9

**W**

Warning Messages .....	9
Watchdog .....	10









**Table A – Template Applications**

Config. Display	Template Title	Analog Input 1 (I/P1)	Analog Input 2 (I/P2)	Analog Input 3 (I/P3) *
1. 5L	Single loop	Process Variable		Feedback †
2. 5L	Single loop + Remote set point	Process Variable	Remote Set Point	Feedback †
3. 8.	Auto/Manual station (low signal select)	Process Variable	Master Output	–
4. 8.	Auto/Manual station (digital select)	Process Variable	Master Output	–
5. 8b	Analog backup (low signal select)	Process Variable	Master Output	–
6. 8b	Analog backup (digital select)	Process Variable	Master Output	–
7. In	Single indicator/manual loader	Process Variable	–	–
8. In	Double indicator/manual loader	Process Variable 1	Process Variable 2	–

\* Only available with option board fitted

† Motorized Valve output types only

**Table B – Output Sources**

**Note.** Settings shown in **bold** are fixed and cannot be adjusted. Other settings are changed in Level C/ Output Assignment.

Setting	Output Type	Relays				Analog Outputs		Digital Outputs	
		Rly 1	Rly 2	Rly 3	Rly 4	ao1	ao2	do1	do2
<i>none</i>	None	–	–	–	–	–	–	–	–
<i>ANLG</i>	Analog Output	Alm1#	Alm 2#	Alm 3	Alm 4	<b>OP1</b>	PV	–	–
<i>RLY</i>	Relay Output	<b>OP1</b>	Alm 1#	Alm 2	Alm 3	PV	CSPT	–	–
<i>DIG</i>	Digital Output	Alm 1	Alm 2	Alm 3	Alm 4	OP1	PV	<b>OP1</b>	–
<i>PFB</i>	Motorized valve with FB*	<b>OPEN</b>	<b>CLOSE</b>	Alm 1	Alm 2	PV	CSPT	–	–
<i>band</i>	Motorized valve without FB	<b>OPEN</b>	<b>CLOSE</b>	Alm 1	Alm 2	PV	CSPT	–	–
<i>HCCR</i>	Heat/Cool	<b>OP1</b> (Heat)	<b>OP2</b> (Cool)	Alm 1	Alm 2	PV	CSPT	–	–
<i>HCRd</i>	Heat/Cool	<b>OP1</b>	Alm 1	Alm 2	Alm 3	–	PV	<b>OP2</b>	–
<i>HCDr</i>	Heat/Cool	<b>OP2</b>	Alm 1	Alm 2	Alm 3	–	PV	<b>OP1</b>	–
<i>HCDd</i>	Heat/Cool*	Alm 1	Alm 2	Alm 3	Alm 4	–	–	<b>OP1</b>	<b>OP2</b>
<i>HCRr</i>	Heat/Cool	<b>OP2</b>	Alm 1	Alm 2	Alm 3	<b>OP1</b>	PV	–	–
<i>HCRd</i>	Heat/Cool*	Alm 1	Alm 2	Alm 3	Alm 4	<b>OP1</b>	PV	–	<b>OP2</b>
<i>HCDR</i>	Heat/Cool*	Alm 1	Alm 2	Alm 3	Alm 4	<b>OP1</b>	<b>OP2</b>	–	–

\* Only available with option board fitted

# Relay 1 is assigned to energize when in manual mode and templates 3, 4, 5 or 6 are selected

Alm = Alarm

Rly = Relay

ao1 = Analog Output1

ao2 = Analog Output2

do1 = Digital Output 1

do2 = Digital Output 2

OP1, 2 = Output 1, 2

PV = Process Variable

RTX

CSPT = Set Point RTX

## REFERENCE TABLES

### Table C – Digital Sources

Source Type	Display	Description	Source Type	Display	Description
<b>Control Outputs</b>	<i>OP 1</i>	Control output 1 (heat)	<b>Failure States</b>	<i>F. In. 1</i>	Input 1 failed
	<i>OP 2</i>	Control output 2 (cool)		<i>F. In. 2</i>	Input 2 failed
	<i>OPEN</i>	Motorized valve Open Relay		<i>F. In. 3</i>	Input 3 failed
	<i>CLSE</i>	Motorized valve Close Relay		<i>LbP.1</i>	Loop break - analog output 1
<b>Process Alarms</b>	<i>A 1</i>	Alarm 1 active		<i>LbP.2</i>	Loop break - analog output 2
	<i>A 2</i>	Alarm 2 active		<i>dDG</i>	Watchdog active
	:			<i>PF</i>	Power fail
<b>Alarm Acknowledge</b>	<i>ACK. 1</i>	Alarm 1 acknowledge	<b>Logic equations*</b>	<i>LG 1</i>	Logic equation 1 true
	<i>ACK. 2</i>	Alarm 2 acknowledge		<i>LG 2</i>	Logic equation 2 true
	<i>ACK. 8</i>	Alarm 8 acknowledge	:		
<b>Digital inputs</b>	<i>D.01</i>	Digital input 1 active	<b>Timers</b>	<i>LG 6</i>	Logic equation 6 true
	<i>D.02</i>	Digital input 2 active		<i>rEt 1</i>	Real time alarm 1
	<i>D.03</i>	Digital input 3 active		<i>rEt 2</i>	Real time alarm 2
	<i>D.04</i>	Digital input 4 active		<i>dEt 1</i>	Delay timer 1
<b>Control Modes</b>	<i>_RN</i>	Manual mode selected	<b>MODBUS</b>	<i>_b.1</i>	MODBUS Signal 1
	<i>RUt</i>	Auto mode selected		<i>_b.2</i>	MODBUS Signal 2
	<i>LGL</i>	Local set point/ Local control selected		<i>_b.3</i>	MODBUS Signal 3
	<i>rE_</i>	Remote set point/ Remote control selected		<i>_b.4</i>	MODBUS Signal 4
			<b>Other</b>	<i>On</i>	Always enabled

\* The default factory settings for each logic equation is:

LG1 - The OR of all alarm states; LG2 - The AND of all alarm states

LG3 - The OR of the alarm acknowledge states

LG4 - The OR of the first four alarm state; LG5 - The OR of the second four alarm states

LG6 - The OR of the input fail states

### Table D – Analog Sources

Display	Description	Display	Description
<i>OP 1</i>	Control output 1 (heat)	<i>SSPt</i>	Slave setpoint
<i>OP 2</i>	Control output 2 (cool)	<i>dEU.1</i>	PID deviation (PV – control setpoint)
<i>PV.1</i>	Process variable 1	<i>RVp</i>	Actual valve position
<i>PV.2</i>	Process variable 2	<i>bLP.1</i>	Maths block 1 output
<i>I/P 1</i>	Analog input 1	<i>bLP.2</i>	Maths block 2 output
<i>I/P 2</i>	Analog input 2	<i>bLP.3</i>	Maths block 3 output
<i>I/P 3</i>	Analog input 3	<i>bLP.4</i>	Maths block 4 output
<i>CSPt</i>	Control setpoint	<i>CU5.1</i>	Custom linearizer 1 output
<i>rSPt</i>	Remote setpoint	<i>CU5.2</i>	Custom linearizer 2 output
<i>LSP 1</i>	Local setpoint 1	<i>PID.1</i>	PID block output
<i>LSP 2</i>	Local setpoint 2	<i>r.b.</i>	Remote set point ratio/bias
<i>LSP 3</i>	Local setpoint 3		
<i>LSP 4</i>	Local setpoint 4		

# PRODUCTS & CUSTOMER SUPPORT

## Products

### Automation Systems

- *for the following industries:*
  - Chemical & Pharmaceutical
  - Food & Beverage
  - Manufacturing
  - Metals and Minerals
  - Oil, Gas & Petrochemical
  - Pulp and Paper

### Drives and Motors

- *AC and DC Drives, AC and DC Machines, AC motors to 1kV*
- *Drive systems*
- *Force Measurement*
- *Servo Drives*

### Controllers & Recorders

- *Single and Multi-loop Controllers*
- *Circular Chart and Strip Chart*
- *Paperless Recorders*
- *Process Indicators*

### Flexible Automation

- *Industrial Robots and Robot Systems*

### Flow Measurement

- *Electromagnetic Flowmeters*
- *Mass Flow Meters*
- *Turbine Flowmeters*
- *Flow Elements*

### Marine Systems & Turbochargers

- *Electrical Systems*
- *Marine Equipment*
- *Offshore Retrofit and Re-ferbishment*

### Process Analytics

- *Process Gas Analysis*
- *Systems Integration*

### Transmitters

- *Pressure*
- *Temperature*
- *Level*
- *Interface Modules*

### Valves, Actuators and Positioners

- *Control Valves*
- *Actuators*
- *Positioners*

### Water, Gas & Industrial Analytics

#### Instrumentation

- *pH, conductivity, and dissolved oxygen transmitters and sensors*
- *ammonia, nitrate, phosphate, silica, sodium, chloride, fluoride, dissolved oxygen and hydrazine analyzers.*
- *Zirconia oxygen analyzers, katharometers, hydrogen purity and purge-gas monitors, thermal conductivity.*

## Customer Support

We provide a comprehensive after sales service via a Worldwide Service Organization. Contact one of the following offices for details on your nearest Service and Repair Centre.

### United Kingdom

ABB Limited  
Tel: +44 (0)1480 475 321  
Fax: +44 (0)1480 217 948

### United States of America

ABB Inc  
Instrumentation Division  
Tel: +1 215-674-6000  
Fax: +1 215-674-7183

### Client Warranty

Prior to installation, the equipment referred to in this manual must be stored in a clean, dry environment, in accordance with the Company's published specification.

Periodic checks must be made on the equipment's condition. In the event of a failure under warranty, the following documentation must be provided as substantiation:

1. A listing evidencing process operation and alarm logs at time of failure.
2. Copies of all storage, installation, operating and maintenance records relating to the alleged faulty unit.

---

**ABB** has Sales & Customer Support expertise  
in over 100 countries worldwide

[www.abb.com](http://www.abb.com)

The Company's policy is one of continuous product improvement  
and the right is reserved to modify the information contained  
herein without notice.

Printed in UK (01.06)

© ABB 2006



**ABB Limited**

Howard Road, St. Neots  
Cambridgeshire, PE19 8EU  
UK

Tel: +44 (0)1480 475 321  
Fax: +44 (0)1480 217 948

**ABB Inc.**

125 E. County Line Road  
Warminster  
PA 18974  
USA

Tel: +1 215 674 6000  
Fax: +1 215-674 7183