

Technical Manual

Blind Actuator



Blind Actuator
BA-M-0.4.1 (6253/0.4)

| | | |
|-----|--|----|
| 1 | Notes on the instruction manual | 3 |
| 2 | Safety | 4 |
| 2.1 | Used symbols | 4 |
| 2.2 | Intended use | 5 |
| 2.3 | Improper use | 5 |
| 2.4 | Target group / qualification of personnel | 5 |
| 2.5 | Liability and warranty | 5 |
| 3 | Environment | 6 |
| 4 | Product description | 7 |
| 4.1 | Scope of supply | 7 |
| 4.2 | Overview of types | 7 |
| 4.3 | Function overview | 8 |
| 4.4 | Description of functions | 9 |
| 4.5 | Device overview of blind actuator 4gang BA-M-0.4.1 | 11 |
| 5 | Technical data | 12 |
| 5.1 | Overview of BA-M-0.4.1 | 12 |
| 5.2 | Dimensions | 14 |
| 5.3 | Connection diagram | 15 |
| 6 | Mounting | 16 |
| 6.1 | Safety instructions for mounting | 16 |
| 6.2 | Installation/mounting | 18 |
| 6.3 | Electrical connection | 18 |
| 6.4 | Dismantling | 18 |
| 7 | Commissioning | 19 |
| 7.1 | Allocation of devices and specifying channels | 20 |
| 7.2 | Setting options per channel | 24 |
| 7.3 | Linking | 27 |
| 8 | Updating options | 28 |
| 9 | Maintenance | 29 |
| 9.1 | Cleaning | 29 |

1 Notes on the instruction manual

Please read this manual through carefully and adhere to the information contained therein. This will assist you in preventing damage to persons and property and ensure reliable operation and long service life of the device.

Please keep this manual in a safe place.

If you pass the device on, also include this manual.

If you require additional information or have questions about the device, please contact ABB STOTZ-KONTAKT GmbH or visit our Internet site at:

www.abb.com/freeathome

2 Safety

The device has been constructed according to the latest valid regulations governing technology and is operationally reliable. It has been tested and left the factory in a technically safe and reliable state.

However, residual hazards remain. Read and adhere to the safety instructions to prevent such hazards.

ABB STOTZ-KONTAKT GmbH accepts no liability for failure to observe the safety instructions.

2.1 Used symbols

The following symbols point to particular dangers involved in the use of the device and provide practical instructions.

| |
|--|
| Notice |
| A notice indicates information or references to additional useful topics. This is not a signal word for a dangerous situation. |

| |
|--|
| Examples |
| Examples for application, installation and programming |

| |
|--|
| Important |
| This safety notice is used as soon as there is the danger of malfunction without the risk of damage to property or risk of injury. |

| |
|--|
| Caution |
| This safety notice is used as soon as there is the danger of malfunction without the risk of damage to property or risk of injury. |

| |
|--|
|  Danger |
| This safety notice is used as soon as there is a threat to life and limb due to improper handling. |

| |
|---|
|  Danger |
| This safety notice is used as soon as there is a serious threat to life due to improper handling. |

2.2 Intended use

The device must only be operated within the specified technical data.

The blind actuator is a rail mounting device for installing in the distributor.

The device serves for the activation of motors (230 V AC / 24 V DC) for sun protection products, such as Venetian blinds, roller blinds, exterior blinds, awnings, shades, curtains, vertical blinds, etc.

The integrated bus coupler makes possible the connection to the free@home bus.

2.3 Improper use

The device is dangerous if used improperly. Any non-intended use is deemed improper use. The manufacturer is not liable for damages resulting from such improper use. The associated risk is borne exclusively by the user/operator.

The device must never be used outdoors or in bathroom areas. Do not push objects through the openings in the device. Only the available options for connection are to be used in accordance with the technical data.

The device has an integrated bus coupler.

2.4 Target group / qualification of personnel

Installation, commissioning and maintenance of the product must only be carried out by trained and properly qualified electrical installers. The electrical installer must have read and understood the manual and follow the instructions provided. The operator must adhere to the valid national regulations in his country governing the installation, functional test, repair and maintenance of electrical products.

2.5 Liability and warranty

Improper use, non-observance of this manual, the use of inadequately qualified personnel, as well as unauthorized modification excludes the liability of the manufacturer for the damages caused. It voids the warranty of the manufacturer.

3 Environment

Always dispose of the packaging material and electric devices and their components via the authorized collecting depots and disposal companies.

The products meet the legal requirements, in particular the laws governing electronic and electrical devices and the REACH ordinance.

(EU Directive 2006/96/EC, 2004/108/EC and 2011/65/EC RoHS)

(EU REACH ordinance and law for the implementation of the ordinance (EC) No.1907/2006)

4 Product description

The device is a blind actuator for installing on a mounting rail. The device has four channels and serves as actuator for the activation of blinds, roller blinds or awnings.

Advantages:

- » Four channels for the activation of four blinds, roller blinds or awnings.
- » Drives of 24 V AC to 230 V AC are supported.
- » Two channels can always be protected with a common circuit-breaker.

Note

Basic information about system integration is contained in the system manual. It is available for downloading at www.abb.com/freeathome.

4.1 Scope of supply

The scope of supply contains the blind actuator including bus terminal for coupling to the free@home bus.

4.2 Overview of types

| Type | Product name | Actuator channels | Device |
|------------|-----------------------|-------------------|---|
| BA-M-0.4.1 | Blind actuator, 4gang | 4 |  |

Table 1: Overview of types

4.3 Function overview

The following table provides an overview of the possible functions and applications of the device:

| Icon in the operating surface | Information |
|---|--|
|  | Name: Blind actuator For the activation of blinds, roller blinds and awnings, etc. |

Table 2: Function overview

4.4 Description of functions

This function is to be selected to operate blinds, roller blinds or awnings via push-buttons coupled to binary inputs, for example. The operation of blinds can be carried out via single or double push-buttons (please observe the product manual of the respective binary inputs). When using single push-buttons, long button actuations lead alternately to upward or downward movement of the blind, the roller blind or the awning. Short push-button actuations cause the blind to stop, or alternately to an upward or downward movement of the slats (if a roller blind or awning is operated on the blind actuator, the parameter "Total slat movement time [ms]" must be set on 0 in the parameter settings of the blind actuator, and brief push-button actuations serve exclusively for stopping. For additional information see section 7.2.3). When using a double push-button, a long press of the left rocker causes the blind to move up and a brief press to the upward movement of the slats. Downward movements are carried out analogous via the right rocker.

4.4.1 Blind force-position

The blind actuator supports the free@home protective function "Blind force-position". This function can be triggered by a connected free@home device (which supports this function). In the triggering free@home device it can be specified whether the blind is to move to the upper (parameter "Force-position top") or the bottom end position (parameter "Force-position bottom") when this function is activated.

Example

By means of a push-button connected to a binary input the blind force-position is triggered with the configuration "Force-position top". The blind then moves to the top end position and can then not be controlled by other control elements or push-buttons until the force-position is deactivated with a renewed press of the push-button connected to the binary input.

4.4.2 Frost, rain and wind alarm

This function is to be selected if sensors are used for the detection of frost, rain and wind and are coupled with the bus via a binary input. These functions are supported automatically by the blind actuator as soon as the respective sensor has been linked in menu "Linking" in the main menu of the System Access Point with the protective channel of the blind actuator.

If a frost alarm is detected, the movement of the blind (and roller blind or awning) connected to the corresponding channel of the blind actuator is blocked to prevent damage. If at the time of the frost alarm a movement command is being carried out, this is terminated before the blockage. During a wind or rain alarm the blind (and roller blind or awning) moves immediately to the top end position to prevent damage. The alarm message is carried out as long as rain, wind or frost is detected. After a rain or wind alarm is finished the blind (roller blind or awning) automatically moves back to the position at which the alarm was triggered.

4.4.3 Scene function

Each of the four channels can be integrated in up to sixteen scenes.

4.5 Device overview of blind actuator 4gang BA-M-0.4.1

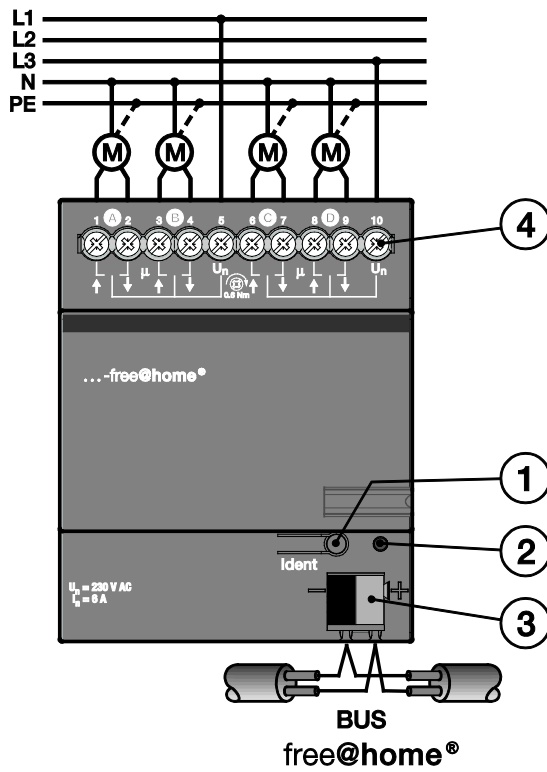

Fig 1: Device overview of 4gang blind actuator

- [1] Device identification during commissioning
- [2] Identification LED
- [3] Bus connection terminal
- [4] Connecting terminals for blind, roller blind or awning motors

5 Technical data

5.1 Overview of BA-M-0.4.1

| Parameters | Value | |
|--------------------------|---|---|
| Power supply | 24 V DC (via the bus) | |
| Bus subscribers | 1 (12 mA) | |
| Connection (free@home) | Bus connection terminal: 0.4 - 0.8 mm | |
| Line type | J-Y(St)Y, 2 x 2 x 0.8 mm | |
| Nominal voltage | 24 to 230 V AC 50/60 Hz | |
| Max. switching current | 6 A (AC1/AC3) at 230 V AC | |
| Outputs | 4 independent outputs with 2 switchover actuators each (mechanically locked Up/Down against each) | |
| Connecting terminals | 2 screw-type terminals for power supply system, different phases are possible. 2 screw-type terminals per output for Up and Down | |
| | Combi-head screw-type terminal (PZ 1) | Connection cross section: 0.2 - 4.0 mm ² fine-wire, 2 x 0.2...2.5 mm ² 0.2 - 6.0 mm ² single-wire, 2 x 0.2...4.0 mm ² |
| | Tightening torque | 0.6 Nm |
| Ambient temperature | Operation | -5°C to +45°C |
| | Storage | -25°C to +55°C |
| | Transport | -25°C to +70°C |
| Environmental conditions | Maximum humidity | 93%, no dew permissible |
| Protection type | IP20 | Acc. to DIN EN 60 529 |
| Protection class | II | Acc. to DIN EN 61 140 |
| Insulation category | Over voltage category | III acc. to DIN EN 60 664-1 |
| | Degree of contamination | 2 acc. to DIN EN 60 664-1 |
| Mounting | On 35 mm mounting rail | Acc. to DIN EN 60 715 |
| Built-in position | Any | |

| | | |
|------------|---|---|
| Design | Rail mounting device (MDRC) | Modular installation device, Pro <i>M</i> |
| | Installation width | 4 modules à 18 mm |
| | Installation depth | 64.5 mm |
| | Housing, colour | Plastic, basalt grey (RAL 7012) |
| Dimensions | 72 x 90 x 64.5 mm (W x H x D) | |
| Weight | 0.22 kg | |
| CE marking | According to EMC and low-voltage guidelines | |

Table 3: Technical data

5.2 Dimensions

| |
|---------------------------|
| Note |
| All dimensions are in mm. |

Blind actuator BA-M-0.4.1

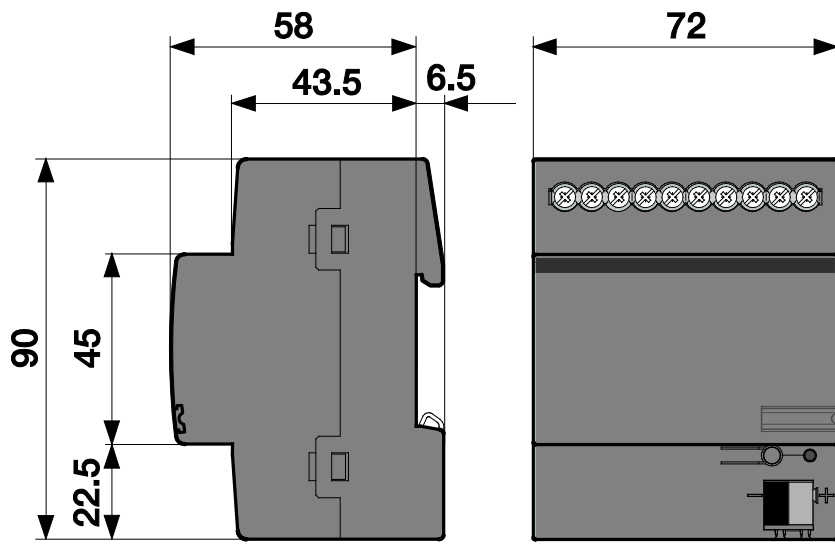

Fig. 2: Dimensions of 4gang blind actuator

5.3 Connection diagram

Blind actuator BA-M-0.4.1

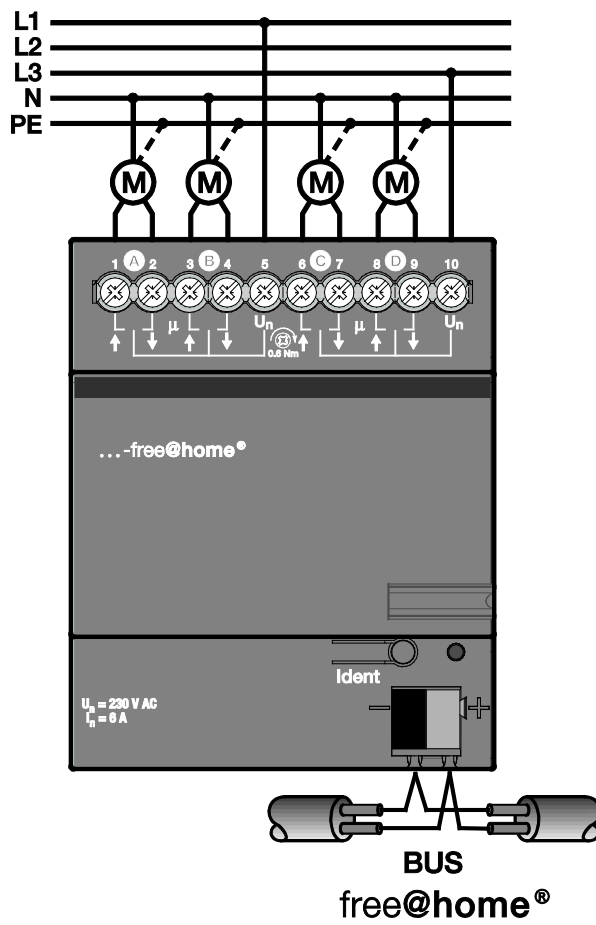

Fig. 3: Electrical connection of 4gang blind actuator

6 Mounting

6.1 Safety instructions for mounting



Danger

Risk of death due to electrical voltage

Dangerous currents flow through the body when coming into direct or indirect contact with live components. This results in electric shock, burns or even death.

Work improperly carried out on electrical systems is a hazard to one's own life and that of the user. Also fires and serious damage to property can result.

- » Observe the relevant standards.
- » Apply at least the "five safety rules" (DIN VDE 0105, EN 50 110):
 1. Disconnect
 2. Secure against being re-connected
 3. Ensure there is no voltage
 4. Connect to earth and short-circuit
 5. Cover or barricade adjacent live parts
- » Install the device only if you have the necessary electrical engineering knowledge and experience (see chapter 2.4).
- » Use suitable personal protective clothing.
- » Use suitable tools and measuring devices.
- » Check the supply network type (TN system, IT system, TT system) to secure the following power supply conditions (classic connection to ground, protective earthing, necessary additional measures, etc.).

**Danger****Risk of death due to short-circuit**

Risk of death due to electrical voltage of 230 V during short-circuit in the low-voltage line.

- » During mounting observe the spatial division (> 10 mm) of SELV electric circuits to other electric circuits.
- » Observe the spatial division of SELV electric circuits and other electric circuits. Otherwise short-circuits can occur.

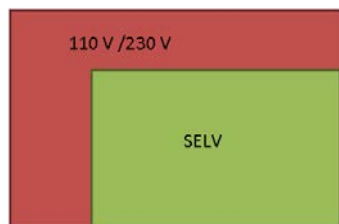

- » If the minimum distance is insufficient, use electronic boxes or insulating tubes.
- » Observe the correct polarity.

6.2 Installation/mounting

The device is a rail mounting device for installing in distributors for easy installation on 35 mm mounting rails according to DIN EN 60 715.

The device can be mounted in any position.

The stick-on label is to be removed and glued into the list (see system manual System Access Point).

The bus connection is established by means of the enclosed bus connection terminal.

The device is ready for operation after the bus voltage and, if required, an auxiliary voltage has been applied.

The description of the terminals is found on the housing.

Access to the device must be guaranteed for operation, testing, inspection, maintenance and repairs according to DIN VDE 0100-520.

6.3 Electrical connection

- » The electrical connection is made via screw terminals. The bus connection is established by means of the enclosed bus connection terminal. The terminal designation is located on the housing.
- The device is ready for operation after the bus voltage has been applied.

Mounting and commissioning must only be carried out by qualified electrical installers. When planning and setting up electrical systems and security-related systems for the detection of intrusion and of fires, the relevant standards, guidelines, rules and regulations of the respective country are to be observed.

- » Protect the device against humidity, dirt and damage during transport, storage and operation!
- » Operate the device only within the specified technical data!
- » Operate the device only in a closed housing (distributor)!
- » Prior to performing installation work the device is to be deactivated.



Danger

Danger to life

To prevent dangerous contact currents due to feedback from different external conductors, an all-pole deactivation is to be carried out when extending or changing the electric connection.

6.4 Dismantling

Dismantling is carried out in the reverse order.

7 Commissioning

Commissioning is always carried out via the Web-based surface of the System Access Point.

The System Access Point establishes the connection between the free@home participants and the smartphone, tablet or PC. It is used to identify and program the participants during commissioning.

Devices which are physically connected to the free@home bus, log themselves automatically into the System Access Point. They transmit information about their type and supported functions (see Table 2: Function overview, chapter 4.3).

During initial commissioning all devices are given a generic name (e.g. switch actuator 1, etc.). The user must change this name to a name practical for the system (Example: "Living room light" for an actuator in the living room).

The devices must be parameterised for the use of additional functions.

Commissioning of the blind actuator is described in the following chapters. Here it is assumed that the basic commissioning steps of the overall system have already been carried out. General knowledge about the Web-based commissioning software of the System Access Point is assumed.

Note

General information about commissioning and parameterization is available in the system manual and the online Help of the "System Access Point" (www.abb.com/freeathome).

7.1 Allocation of devices and specifying channels

The devices connected to the system must be identified, i.e. they are allocated to a room according to their function and are given a descriptive name.

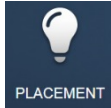

The allocation is made via the allocation function of the Web-based user interface of the System Access Point.

Device selection

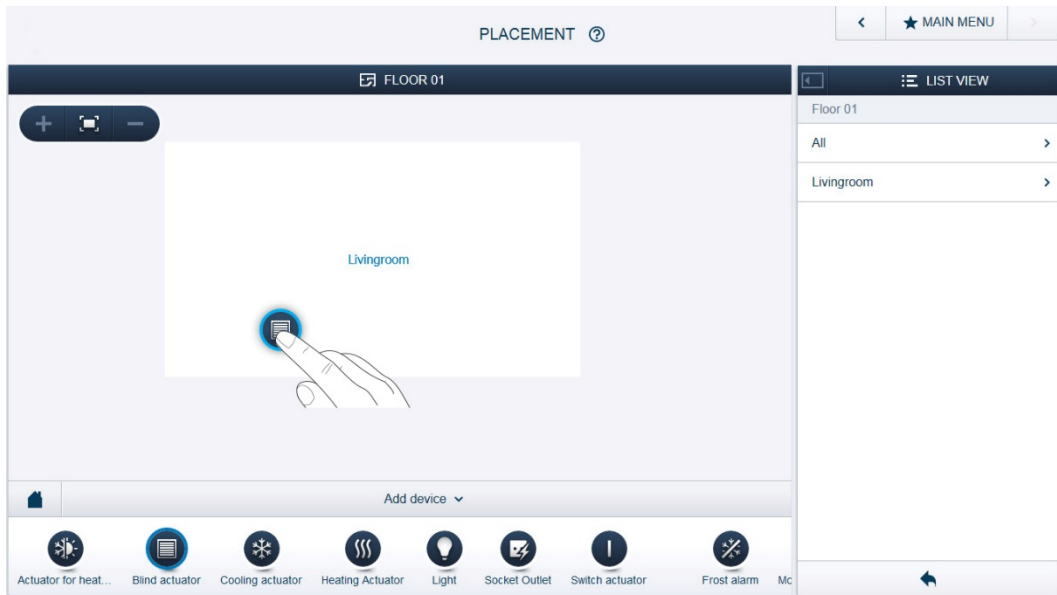

Fig. 4: Allocating devices

- » In the "Add device" bar select the desired application and pull it via drag-and-drop onto the floor plan in the working area.

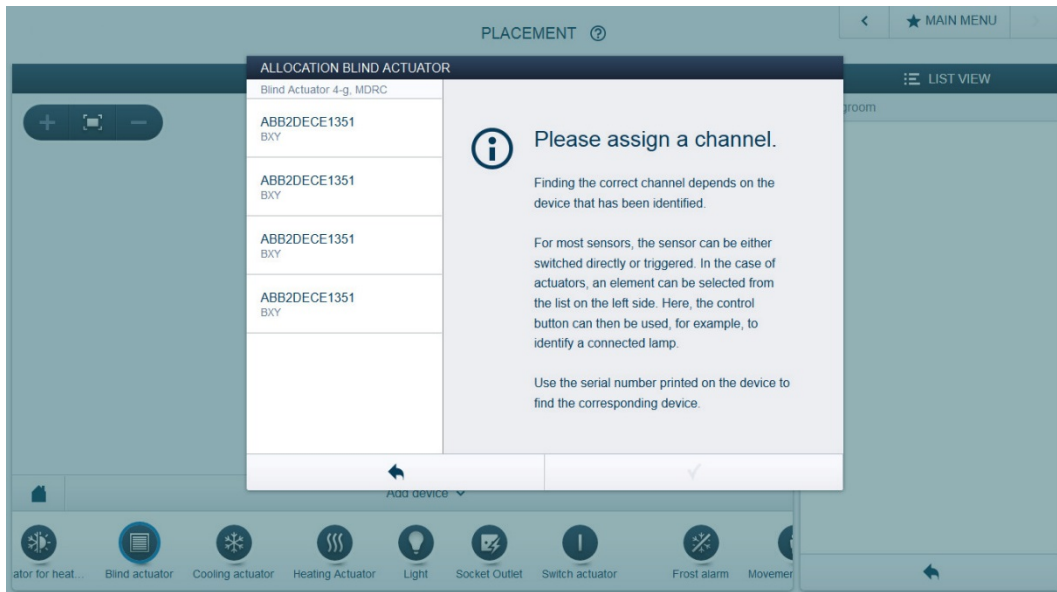

Fig. 5: Allocation

- A pop-up window opens automatically which lists all the devices suitable for the application selected.

The desired device can be identified in two ways.

Identification via serial number

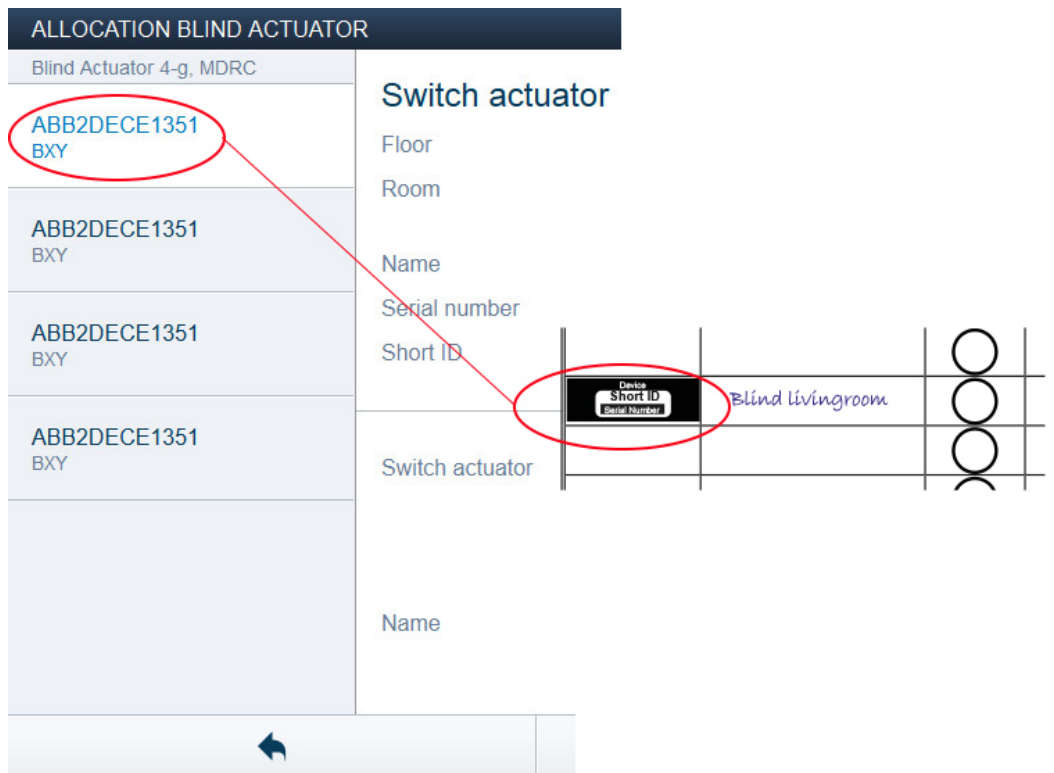

Fig. 6 Identification via serial number

- » Compare the short 3-digit number of the identification label with the numbers in the list and in this way identify the device you are searching for and, if necessary, also the channel.

Identification by pressing the "Identification button"

- » Press the identification button on the device which you wish to add.
- The desired device is faded in automatically.
- » Select the desired channel.

Assigning a name

| ALLOCATION BLIND ACTUATOR | |
|---|--|
| Blind Actuator 4-g, MDRC | |
| ABB2DECE1351 BXY | Switch actuator |
| ABB2DECE1351 BXY | Floor Floor 01 |
| ABB2DECE1351 BXY | Room Livingroom |
| ABB2DECE1351 BXY | Name Blind Actuator 4-g, MDRC |
| ABB2DECE1351 BXY | Serial number ABB2DECE1351 |
| ABB2DECE1351 BXY | Short ID BXY |
| | Switch actuator  |
| | Name <input type="text" value="Blind livingroom"/> |
| ← ✓ | |

Fig. 7: Assigning a name

- » Enter a name that is easy to understand and under which the application is to be displayed later (e.g. "Living room blind").
- » Press the tick at the bottom right to take over the entry.

Note

The settings of the device can be adjusted via the Web-based user interface of the System Access Point.

For pre-programmed devices the default settings can be adjusted. This allows the channel selection to be influenced.

These settings, however, can only be made with a fitter access (see online Help of the System Access Point). The parameter settings remain as described above.

7.2 Setting options per channel

General settings and parameter settings can be made for each channel.

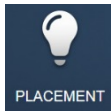

The settings are made via the allocation function of the Web-based user interface of the System Access Point.

Device selection

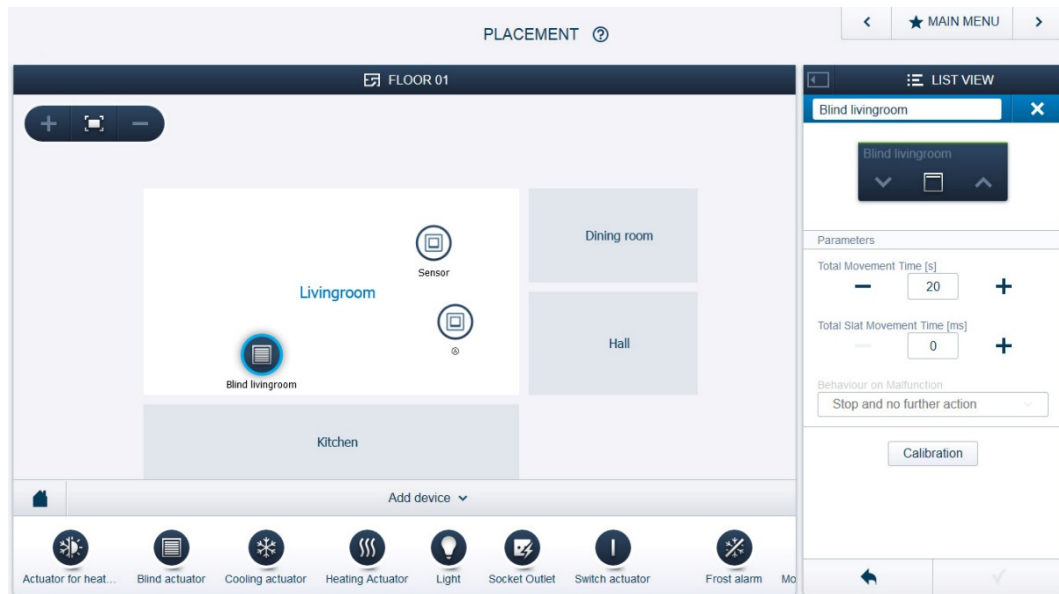
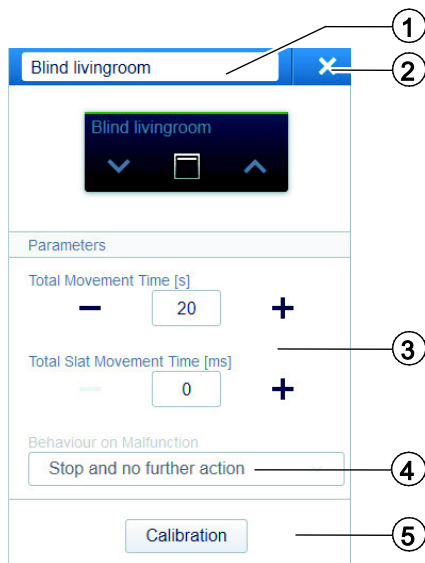

Fig. 8: Device selection

- » Select the device icon in the floor plan of the working area view.
- All setting options for the respective channel are displayed in the list view.

The following settings are available.

7.2.1 Blind actuator settings



- [1] Setting the overall movement time
- [2] Deleting the channel via "X"
- [3] Setting the slat movement time
- [4] Selecting the behaviour during faults
- [5] Calibration

7.2.2 Setting the overall movement time

The parameter "Total movement time" specifies the time a blind requires to move from the one end position to the other end position (e.g. from the bottom end position to the top end position). The time can be measured either manually and entered manually or specified automatically via the calibration function. When selecting the calibration function, the instructions are to be followed: The blind must first be moved to the top end position, then to the bottom end position and then again to the top end position. The movement time is then calculated automatically from the mean value of the movement times from the bottom end position to the top end position and taken over automatically.

7.2.3 Setting the slat movement time

The parameter "Slat movement time" specifies the time the slats require for one complete adjustment. The movement time of the slats is to be determined manually as follows:

- » Move the blind to the bottom end position.
- » Move the blind with brief actuations of the blind button in the parameter setting of the blind actuator in the System Access Point (see illustration above) to the top until the slats no longer move. Count the number of button actuations needed.
- » Determine the total movement time of the slats by multiplying the number of button actuations with 200 ms.
- » Enter the slat movement time thus determined into the field "Total slat movement time [ms]".

Note

If a roller blind or an awning is operated on a blind actuator, the "Total slat movement time [ms]" is to be set to 0 ms.

7.3 Linking

The blind actuator units created via the allocation function can now be linked with a second device (e.g. binary input).

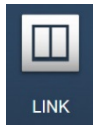

The linking in the list view is then made via the linking function of the Web-based user interface of the System Access Point.

Linking blind actuator and binary input

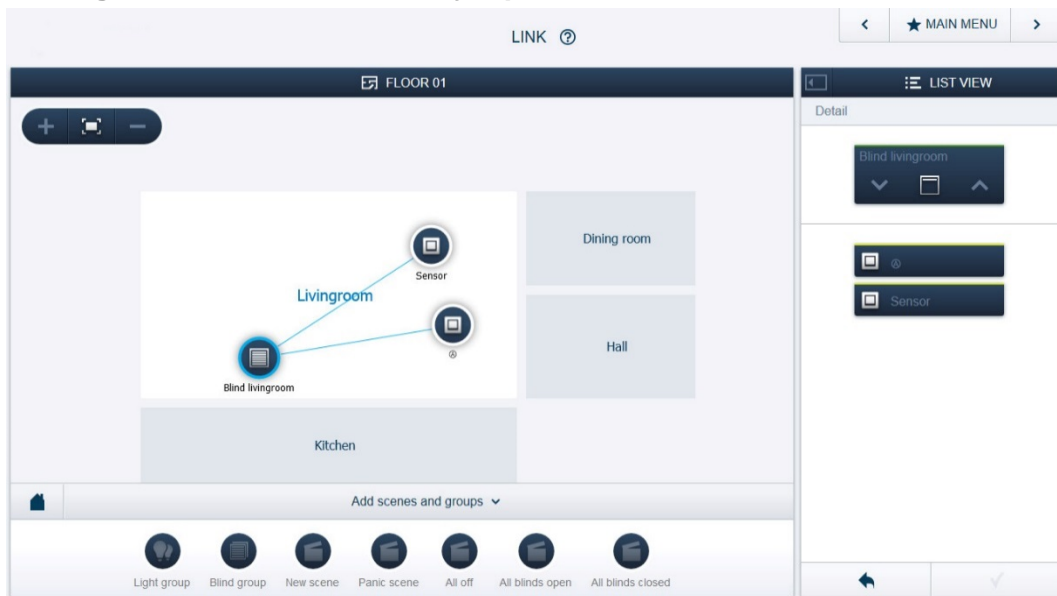

Fig. 9: Linking blind actuator and binary input

- » To link a blind actuator with a binary input, first click on the desired binary input, via which the actuator is to be operated, and then on the blind actuator.
- A blue connecting line indicates the link between the two devices. The configuration is now transmitted automatically to the devices. The transmission can (depending on the number of affected devices) take a number of seconds. During the transmission a progress bar is displayed around the devices affected.
- » To link the actuator with a further binary input or sensor, proceed as described above.

Note

The links can be changed manually at all times.

8 Updating options

A firmware update is carried out via the Web-based user interface of the System Access Point. For this, visit the free@home website www.abb.com/freeathome.

9 Maintenance

The device is maintenance-free. In case of damage (e.g., during transport or storage), do not perform repairs. Once the unit is opened, the warranty is void!

Access to the device must be guaranteed for operation, testing, inspection, maintenance and repairs (according to DIN VDE 0100-520).

9.1 Cleaning

Dirty devices can be cleaned with a dry cloth. If this is not sufficient, a cloth slightly moistened with a soap solution can be used. Caustic cleaning agents or solvents must not be used.

ABB STOTZ-KONTAKT GmbH

Eppelheimer Straße 82
69123 Heidelberg, Germany
Telephone: +49 2351 956-1600

E-mail: knx.helpline@de.abb.com
www.abb.com/freeathome

Further information and contact:



Note:

We reserve the right to make technical modifications to products as well as changes to the content of this document without prior notice. The respective agreed-upon conditions apply to orders. ABB accepts no responsibility for possible errors or incompleteness in this document.

We reserve all rights to this document and the topics and illustrations contained therein. Duplication, disclosure to third parties or the use of its contents - and of parts thereof - is forbidden without prior written approval from ABB AG.

Copyright© 2014 ABB
All rights reserved