

CATALOG

Current Transformers

Enhance your metering solutions

Accurately measure high currents in a compact design, maximizing efficiency in both time and space.



- Accurate and reliable measurement (Class 1 & Class 0.5)
- Complete offering to address all metering needs of new and existing installations
- Compact footprint, allowing to minimize the overall dimensions of the panel
- Small number of order codes covering applications from 50 A to 6000 A for easy and time-saving navigation

Current Transformers

Enhance your metering solutions

Achieve accurate high current measurements with our reliable and compact indirect metering solutions that have been designed to optimize both time and space efficiency.



Accurate and reliable measurement

Ensures Class 1 & Class 0.5 accuracy, even for low primary current transformers and reliable measurement according to the IEC 61869-2 standard.



Complete offering

Covers all metering needs of new and existing installations – from solid and split core current transformers to energy meters, Rogowski coils, DIN-rail transformers, and more.



Easy and time-saving navigation

Small number of order codes for applications from 50 A to 6000 A and multiple connection methods such as DIN rail, cable, busbar, and base mounted with feet.



Compact installation without downtime

Space-saving design to minimize the overall dimensions of the panel. Split-core CTs perfectly fit existing installations with zero downtime – ideal for critical power applications.



CT1M Solid-core Current Transformers

Accurate measurement
Class 0.5 and Class 1
according to IEC 61869-2

Large cable diameter
Suitable for cables
from 21 mm up to 86 mm

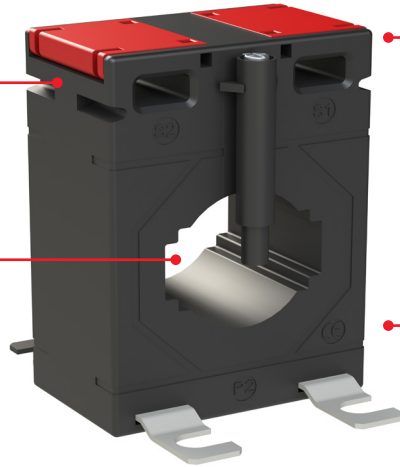

Large range of primary currents
from 50 A up to 6000 A

Suitable for busbars
from 20 x 10 mm to 100 x 30 mm

CT1M-S Split-core Current Transformers

Accurate measurement
Class 0.5 and Class 1
according to IEC 61869-2

Easy upgrades to existing installations thanks to flexible opening and closing of the cable opening

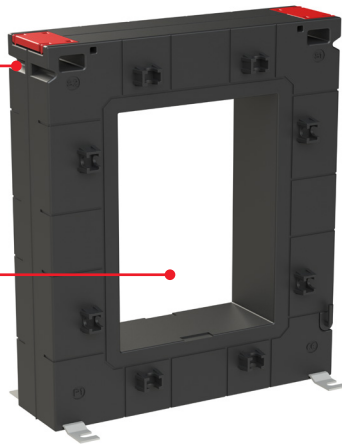

Large range of primary currents
from 100 A up to 1500 A

Suitable for busbars
from 33 x 23 mm to 125 x 85 mm

Compatible with...

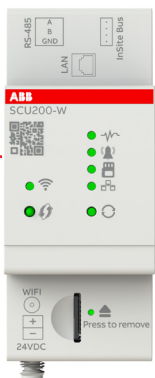

InSite energy management system



Energy meters









Network Analyzers & Multimeters



MCCBs & Air Circuit Breakers (ACBs)

Energy efficiency

Current transformers selection table

Breaker choice*								
Modular	S200, S750DR, S800							
Tmax	XT1, XT2	XT1, XT2, XT3, XT4, XT5	XT5	XT5, XT6	XT6, XT7	XT3, XT4, XT5		
Emax	E1.2							
Installation choice								
Fixing system	DIN rail	DIN rail	DIN rail, Cable or Busbar, Base mounted with feet			Busbar		
								
Class	Rated current (A)	CTA	TRFM	CT1M-2	CT1M-3	CT1M-4	CT1M-5	CT1M-S-30
0.5	10	2CSG111030R1141 CTA/10						
0.5	20	2CSG111050R1141 CTA/20						
0.5	25	2CSG111060R1141 CTA/25						
0.5	40	2CSG111080R1141 CTA/40 (cl. 0.5)	2CSM100050R1111 TRFM/40					
1	50	2CSG111090R1141 CTA/50 (cl. 0.5)		2CSG280225R1000 CT1M-2 50 (Cl.1)				
1	60	2CSG111100R1141 CTA/60 (cl. 0.5)	2CSM100070R1111 TRFM/60 (cl. 1)	2CSG280235R1000 CT1M-2 60 (Cl.1)				
0.5	80	2CSG111110R1141 CTA/80 (cl. 0.5)		2CSG280245R1000 CT1M-2 80				
1	100	2CSG111120R1141 CTA/100 (cl. 0.5)	2CSM100090R1111 TRFM/100	2CSG280255R1000 CT1M-2 100				2CSG280725R1000 CT1M-S-30 100 (Cl.1)
0.5	150		2CSM100100R1111 TRFM/150	2CSG280265R1000 CT1M-2 150				2CSG280735R1000 CT1M-S-30 150 (Cl.1)
0.5	200			2CSG280275R1000 CT1M-2 200				
0.5	250		2CSM100120R1111 TRFM/250	2CSG280285R1000 CT1M-2 250				2CSG280745R1000 CT1M-S-30 250 (Cl.1)
0.5	300			2CSG280295R1000 CT1M-2 300	2CSG280315R1000 CT1M-3 300	2CSG280375R1000 CT1M-4 300		2CSG280755R1000 CT1M-S-30 400
0.5	400		2CSM100140R1111 TRFM/400	2CSG280305R1000 CT1M-2 400	2CSG280325R1000 CT1M-3 400	2CSG280385R1000 CT1M-4 400		
0.5	500				2CSG280335R1000 CT1M-3 500	2CSG280395R1000 CT1M-4 500		
0.5	600		2CSM100160R1111 TRFM/600		2CSG280345R1000 CT1M-3 600	2CSG280405R1000 CT1M-4 600		
0.5	800					2CSG280355R1000 CT1M-4 800		
0.5	1000						2CSG280365- R1000 CT1M-5 1000	

*Breaker choice recommendations are only indicative. For precise information, please refer to the related product catalogs.

XT5, XT6, XT7	XT5, XT6, XT7	XT5, XT6, XT7	XT6, XT7
E1.2, E2.2		E2.2	E2.2, E4.2, E6.2

DIN rail, Cable or Busbar, Base mounted with feet	Busbar	Cable or Busbar, Base mounted with feet	Busbar
---	--------	---	--------

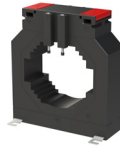

CT1M-6

CT1M-7

CT1M-S-80

CT1M-8

CT1M-10

CT1M-12







CT1M-S-120

2CSG280415R1000 CT1M-6 250	2CSG280765R1000 CT1M-S-80 250			
2CSG280425R1000 CT1M-6 300				
2CSG280435R1000 CT1M-6 400	2CSG280775R1000 CT1M-S-80 400			
2CSG280445R1000 CT1M-6 500	2CSG280785R1000 CT1M-S-80 500			
2CSG280455R1000 CT1M-6 600	2CSG280795R1000 CT1M-S-80 600	2CSG280525R1000 CT1M-8 600	2CSG280605R1000 CT1M-10 600	
2CSG280465R1000 CT1M-6 800	2CSG280805R1000 CT1M-S-80 800	2CSG280535R1000 CT1M-8 800	2CSG280615R1000 CT1M-10 800	2CSG280825R1000 CT1M-S-120 800
2CSG280475R1000 CT1M-6 1000	2CSG280815R1000 CT1M-S-80 1000	2CSG280545R1000 CT1M-8 1000	2CSG280625R1000 CT1M-10 1000	

Energy efficiency







Current Transformers selection table

Breaker choice*							
Modular	S200, S750DR, S800						
Tmax	XT1, XT2	XT1, XT2, XT3, XT4, XT5	XT5	XT5, XT6	XT6, XT7	XT3, XT4, XT5	
Emax	E1.2						
Installation choice							
Fixing system	DIN rail	DIN rail	DIN rail, Cable or Busbar, Base mounted with feet			Busbar	

								
Class	Rated current (A)	CTA	TRF M	CT1M-2	CT1M-3	CT1M-4	CT1M-5	CT1M-S-30
0.5	1200							
05	1250							
0.5	1500							
0.5	2000							
0.5	2500							
0.5	3000							
0.5	4000							
0.5	5000							
0.5	6000							

	CTA	TRF M	CT1M-2	CT1M-3	CT1M-4	CT1M-5	CT1M-S-30
	Wound primary	Through primary	Through primary	Through primary	Through primary	Through primary	Split-core through primary
Cable diameter (mm)	8	29	21	26	31	41	–
Horizontal busbar size	–	–	20x10	30x10, 25x15	40x10, 30x20	50x10, 40x20, 30x30	–
Vertical busbar size	–	–	–	–	40x10, 30x20	–	33x23

*Breaker choice recommendations are only indicative. For precise information, please refer to the related product catalogs.

XT5, XT6, XT7		XT5, XT6, XT7		XT5, XT6, XT7		XT6, XT7	
E1.2, E2.2		E2.2		E2.2, E4.2, E6.2			
DIN rail, Cable or Busbar, Base mounted with feet		Busbar		Cable or Busbar, Base mounted with feet		Busbar	
							
CT1M-6	CT1M-7	CT1M-S-80	CT1M-8	CT1M-10	CT1M-12	CT1M-S-120	
2CSG280485R1000 CT1M-6 1200			2CSG280555R1000 CT1M-8 1200	2CSG280635R1000 CT1M-10 1200		2CSG280835R1000 CT1M-S-120 1200	
				2CSG280705R1000 CT1M-10 1250			
2CSG280495R1000 CT1M-6 1500			2CSG280565R1000 CT1M-8 1500	2CSG280645R1000 CT1M-10 1500		2CSG280845R1000 CT1M-S-120 1500	
2CSG280505R1000 CT1M-6 2000			2CSG280575R1000 CT1M-8 2000	2CSG280655R1000 CT1M-10 2000			
	2CSG280515R1000 CT1M-7 2500			2CSG280585R1000 CT1M-10 2500			
				2CSG280595R1000 CT1M-10 3000	2CSG280665R1000 CT1M-12 3000		
				2CSG280715R1000 CT1M-10 4000	2CSG280675R1000 CT1M-12 4000		
					2CSG280685R1000 CT1M-12 5000		
					2CSG280695R1000 CT1M-12 6000		
CT1M-6	CT1M-7	CT1M-S-80	CT1M-8	CT1M-10	CT1M-12	CT120	
Through primary	Through primary	Split-core through primary	Through primary	-	Through primary	Split-core through primary	
65	-	-	73	86	-	-	
80x10, 60x30, 50x50	101x56	-	80x30, 60x50	100x30, 80x50, 70x60	125x93	-	
80x10, 60x30, 50x50	-	85x55	80x30, 60x50	100x30, 80x50, 70x60	-	125x85	

Energy efficiency

CT1M Current Transformers



CT1M

Technical features					
		CTA	TRFM	CT1M Solid Core	CT1M-S Split Core
Standard secondary current	[A]	5 A	5 A	5 A	5 A
Max. voltage for operation	[kV]	1.2	1.2	0.72	0.72
Test voltage	[kV]	3 a 50 Hz/1min	3 kV 50 Hz/1min	4 kV at 50Hz / 1 min (CT1M-3: 3kV at 50Hz / 1 min)	
Short circuit rated thermal current	[IpN]	40 x In	40 x In	60 x In	60 x In
Short circuit rated dynamic current (Ith)	[Ith]	2.5 Ith for 1 sec	2.5 Ith for 1 sec	2.5 Ith for 1 sec	2.5 Ith for 1 sec
Permanent overload	[IpN]	1.2 x In	1.2 x In	1.2 x In	1.2 x In
Safety factor	[Fs]	from ≤ 2 to ≤ 10 depending on the type and capacity	from ≤ 2 to ≤ 10 depending on the type and capacity	from ≤ 5 to ≤ 15 depending on the type and capacity	from ≤ 10 to ≤ 30 depending on the type and capacity
Frequency	[Hz]	50-60	50-60	50-60	50-60
Terminals		primary P1 - P2 (K - L); secondary s1 - s2 (k - l)			
		P1 (K) primary winding input			
		s1 (k) secondary winding input			
		P2 (L) primary winding output			
		s2 (l) secondary winding output			
Housing		Self-extinguishing thermoplastic resin V0	Self-extinguishing thermoplastic resin V0	UL94V-0	UL94V-0
Insulation class		Class E	Class E	Class E	Class E
Protection degree		IP20	IP20	IP20	IP20
Operating temperature	[°C]	-5°C to +50°C	-25°C to +50°C	-25°C...+40°C	-25°C to +40°C
Storage temperature	[°C]	70°C	-40°C...+80°C	-50°C to +80°C	-50°C to +80°C
Reference standard		IEC EN 60044-1	IEC EN 60044-1	IEC 61869-2	IEC 61869-2

Energy efficiency

CT1M Current Transformers

Overall dimensions			
Product Range	A Width (mm)	B Height (mm)	C Length (mm)
CT1M-2	45	65	40
CT1M-3	50	70	31
CT1M-4	62	78	40
CT1M-5	74	98	45
CT1M-6	104	126	45
CT1M-7	130	170	51
CT1M-8	140	155	45
CT1M-10	140	155	45
CT1M-12	225	206	50
CT1M-S-30	93	106	40
CT1M-S-80	125	158	40
CT1M-S-120	155	198	40

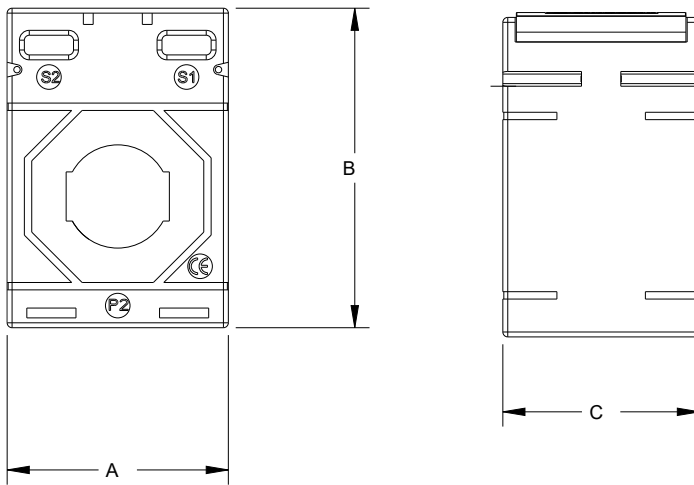

Energy efficiency

CT1M Current Transformers





CT1M-2

CT1M-2 .../5 A series, through primary										
Primary rated current (A)	Best Accuracy class	VA - Class 0.5	VA - Class 1	VA - Class 3	Bbn 8012542	Order details			Weight 1 piece	Pack unit
						EAN	Type code	Order code		
50	1	-	1.5VA	2VA	802259	CT1M-2 50	2CSG280225R1000	0,35	1	
60	1	-	1.5VA	2VA	802358	CT1M-2 60	2CSG280235R1000	0,36	1	
80	0.5	1VA	2.5VA	3VA	802457	CT1M-2 80	2CSG280245R1000	0,36	1	
100	0.5	1.5VA	3.75VA	3.75VA	802556	CT1M-2 100	2CSG280255R1000	0,34	1	
150	0.5	2.5VA	5 VA	5VA	802655	CT1M-2 150	2CSG280265R1000	0,35	1	
200	0.5	3.75VA	5 VA	5VA	802754	CT1M-2 200	2CSG280275R1000	0,35	1	
250	0.5	5VA	5 VA	7.5VA	802853	CT1M-2 250	2CSG280285R1000	0,36	1	
300	0.5	5VA	5 VA	7.5VA	802952	CT1M-2 300	2CSG280295R1000	0,31	1	
400	0.5	5VA	5VA	7.5VA	803058	CT1M-2 400	2CSG280305R1000	0,33	1	

- Busbar and Mounting feet fixings are supplied as standard
- DIN Rail Mounting Adapter available as an option
- Suitable adapter is CT1M-2 DIN Rail Adapter

CT1M-2 Series

Through primary	max section [mm]
Cable 	21
Horizontal bar 	20x10
Vertical bar 	-





CT1M-3

CT1M-3 .../5 A series, through primary										
Primary rated current (A)	Best Accuracy class	VA - Class 0.5	VA - Class 1	VA - Class 3	Bbn 8012542	Order details			Weight 1 piece	Pack unit
						EAN	Type code	Order code		
300	0.5	5VA	5VA	6.25VA	803157	CT1M-3 300	2CSG280315R1000	0,32	1	
400	0.5	5VA	6.25VA	6.25VA	803256	CT1M-3 400	2CSG280325R1000	0,32	1	
500	0.5	5VA	6.25VA	7.5VA	803355	CT1M-3 500	2CSG280335R1000	0,33	1	
600	0.5	5VA	7.5VA	10VA	803454	CT1M-3 600	2CSG280345R1000	0,35	1	

- Busbar and Mounting feet fixings are supplied as standard.
- DIN Rail Mounting Adapter available as an option
- Suitable adapter is CT1M-3 DIN Rail Adapter

CT1M-3 Series

Through primary	max section [mm]
Cable 	26
Horizontal bar 	30x10, 25x15
Vertical bar 	-

CT1M DIN Rail Adapters



CT1M DIN Rail Adapters					
Bbn 8012542	Order details			Weight 1 piece	Pack unit
EAN	Type code	Order code	kg	pc.	
830955	CT1M-2 DIN Rail Adapter	2CSG428309R1000	0,05	1	
831051	CT1M-3 DIN Rail Adapter	2CSG428310R1000	0,05	1	
831150	CT1M-4/5/6/7 DIN Rail Adapter	2CSG428311R1000	0,05	1	

Energy efficiency

CT1M Current Transformers



CT1M-4

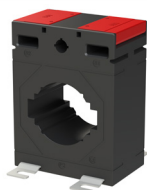

CT1M-5

CT1M-4 & CT1M-5 .../5 A series, through primary										
Primary rated current (A)	Best Accuracy class	VA - Class 0.5	VA - Class 1	VA - Class 3	Bbn 8012542	Order details			Weight 1 piece	Pack unit
						EAN	Type code	Order code		
300	0.5	5VA	5VA	5VA	803751	CT1M-4 300	2CSG280375R1000	0,41	1	
400	0.5	5VA	5VA	7.5VA	803850	CT1M-4 400	2CSG280385R1000	0,42	1	
500	0.5	5VA	7.5VA	10VA	803959	CT1M-4 500	2CSG280395R1000	0,45	1	
600	0.5	7.5VA	10VA	12.5VA	804055	CT1M-4 600	2CSG280405R1000	0,47	1	
800	0.5	10VA	10VA	12.5VA	803553	CT1M-4 800	2CSG280355R1000	0,48	1	
1000	0.5	12.5VA	15VA	20VA	803652	CT1M-5 1000	2CSG280365R1000	0,67	1	

- Busbar and Mounting feet fixings are supplied as standard.
- DIN Rail Mounting Adapter available as an option. Suitable adapter is CT1M-4/5/6/7 DIN Rail Adapter.

CT1M-4 Series

Through primary		max section [mm]
Cable	○	31
Horizontal bar	▭	40x10, 30x20
Vertical bar	▮	40x10, 30x20

CT1M-5 Series

Through primary		max section [mm]
Cable	○	41
Horizontal bar	▭	50X10, 40X20, 30X30
Vertical bar	▮	-



CT1M-6



CT1M-7

CT1M-6 & CT1M-7 .../5 A series, through primary										
Primary rated current (A)	Best Accuracy class	VA - Class 0.5	VA - Class 1	VA - Class 3	Bbn 8012542	Order details			Weight 1 piece	Pack unit
						EAN	Type code	Order code		
250	0.5	1.5VA	2.5VA	3.75VA	804154	CT1M-6 250	2CSG280415R1000	0,66	1	
300	0.5	2.5VA	7.5VA	7.5VA	804253	CT1M-6 300	2CSG280425R1000	0,67	1	
400	0.5	7.5VA	10VA	10VA	804352	CT1M-6 400	2CSG280435R1000	0,64	1	
500	0.5	10VA	10VA	10VA	804451	CT1M-6 500	2CSG280445R1000	0,66	1	
600	0.5	10VA	12.5VA	12.5VA	804550	CT1M-6 600	2CSG280455R1000	0,68	1	
800	0.5	15VA	15VA	15VA	804659	CT1M-6 800	2CSG280465R1000	0,73	1	
1000	0.5	20VA	30VA	20VA	804758	CT1M-6 1000	2CSG280475R1000	0,78	1	
1200	0.5	20VA	30VA	30VA	804857	CT1M-6 1200	2CSG280485R1000	0,83	1	
1500	0.5	20VA	30VA	30VA	804956	CT1M-6 1500	2CSG280495R1000	0,80	1	
2000	0.5	20VA	30VA	35VA	805052	CT1M-6 2000	2CSG280505R1000	0,90	1	
2500	0.5	15VA	15VA	15VA	805151	CT1M-7 2500	2CSG280515R1000	1,42	1	

- Busbar and Mounting feet fixings are supplied as standard.
- DIN Rail Mounting Adapter available as an option. Suitable adapter is CT1M-4/5/6/7 DIN Rail Adapter.

CT1M-6 Series

Through primary		max section [mm]
Cable	○	65
Horizontal bar	▭	80x10, 60x30, 50x50
Vertical bar	▮	80x10, 60x30, 50x50

CT1M-7 Series

Through primary		max section [mm]
Cable	○	-
Horizontal bar	▭	101x56
Vertical bar	▮	-

Energy efficiency

CT1M Current Transformers

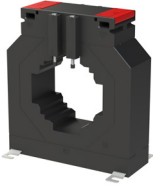



CT1M-8

CT1M-8 .../5 A series, through primary									
Primary rated current (A)	Best Accuracy class	VA - Class 0.5	VA - Class 1	VA - Class 3	Bbn 8012542	Order details		Weight 1 piece	Pack unit
						EAN	Type code		
600	0.5	15VA	30VA	35VA	805250	CT1M-8 600	2CSG280525R1000	1,34	1
800	0.5	15VA	45VA	50VA	805359	CT1M-8 800	2CSG280535R1000	1,39	1
1000	0.5	30VA	60VA	60VA	805458	CT1M-8 1000	2CSG280545R1000	1,45	1
1200	0.5	30VA	60VA	60VA	805557	CT1M-8 1200	2CSG280555R1000	1,31	1
1500	0.5	60VA	60VA	60VA	805656	CT1M-8 1500	2CSG280565R1000	1,18	1
2000	0.5	60VA	60VA	60VA	805755	CT1M-8 2000	2CSG280575R1000	1,29	1

- Busbar and Mounting feet fixings are supplied as standard.

CT1M-8 Series

Through primary	max section [mm]	
Cable		73
Horizontal bar		80x30, 60x50
Vertical bar		80x30, 60x50

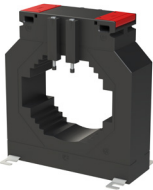



CT1M-10

CT1M-10 .../5 A series, through primary									
Primary rated current (A)	Best Accuracy class	VA - Class 0.5	VA - Class 1	VA - Class 3	Bbn 8012542	Order details		Weight 1 piece	Pack unit
						EAN	Type code		
600	0.5	10VA	15VA	15VA	806059	CT1M-10 600	2CSG280605R1000	0,92	1
800	0.5	15VA	20VA	25VA	806158	CT1M-10 800	2CSG280615R1000	0,97	1
1000	0.5	15VA	20VA	25VA	806257	CT1M-10 1000	2CSG280625R1000	1,01	1
1200	0.5	15VA	30VA	30VA	806356	CT1M-10 1200	2CSG280635R1000	1,06	1
1250	0.5	15VA	30VA	35VA	807056	CT1M-10 1250	2CSG280705R1000	1,08	1
1500	0.5	20VA	30VA	40VA	806455	CT1M-10 1500	2CSG280645R1000	1,14	1
2000	0.5	45VA	45VA	45VA	806554	CT1M-10 2000	2CSG280655R1000	1,11	1
2500	0.5	45VA	45VA	45VA	805854	CT1M-10 2500	2CSG280585R1000	1,05	1
3000	0.5	60VA	60VA	60VA	805953	CT1M-10 3000	2CSG280595R1000	1,14	1
4000	0.5	60VA	60VA	60VA	807155	CT1M-10 4000	2CSG280715R1000	1,33	1

- Busbar and Mounting feet fixings are supplied as standard.

CT1M-10 Series

Through primary	max section [mm]	
Cable		86
Horizontal bar		100x30, 80x50, 70x60
Vertical bar		100x30, 80x50, 70x60

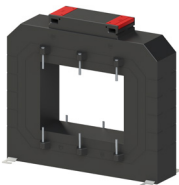



CT1M-12

CT1M-12 .../5 A series, through primary									
Primary rated current (A)	Best Accuracy class	VA - Class 0.5	VA - Class 1	VA - Class 3	Bbn 8012542	Order details		Weight 1 piece	Pack unit
						EAN	Type code		
3000	0.5	30VA	60VA	60VA	806653	CT1M-12 3000	2CSG280665R1000	2,04	1
4000	0.5	45VA	60VA	60VA	806752	CT1M-12 4000	2CSG280675R1000	2,27	1
5000	0.5	100VA	100VA	100VA	806851	CT1M-12 5000	2CSG280685R1000	1,49	1
6000	0.5	100VA	100VA	100VA	806950	CT1M-12 6000	2CSG280695R1000	1,52	1

- Busbar and Mounting feet fixings are supplied as standard.

CT1M-12 Series

Through primary	max section [mm]	
Cable		-
Horizontal bar		125x93
Vertical bar		-

Energy efficiency

CT1M Current Transformers

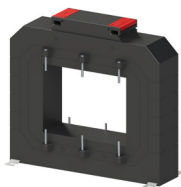

CT1M-12

CT1M-12 .../5 A series, through primary										
Primary rated current (A)	Best Accuracy class	VA - Class 0.5	VA - Class 1	VA - Class 3	Bbn 8012542	Order details			Weight 1 piece	Pack unit
						EAN	Type code	Order code		
3000	0.5	30VA	60VA	60VA	806653	CT1M-12 3000	2CSG280665R1000	2,04	1	
4000	0.5	45VA	60VA	60VA	806752	CT1M-12 4000	2CSG280675R1000	2,27	1	
5000	0.5	100VA	100VA	100VA	806851	CT1M-12 5000	2CSG280685R1000	1,49	1	
6000	0.5	100VA	100VA	100VA	806950	CT1M-12 6000	2CSG280695R1000	1,52	1	

- Busbar and Mounting feet fixings are supplied as standard.

CT1M-12 Series

		max section [mm]
Through primary		
Cable	○	-
Horizontal bar	▭	125x93
Vertical bar	▭	-



CT1M-S-30

CT1M-S-30 .../5 A series, through primary										
Primary rated current (A)	Best Accuracy class	VA - Class 0.5	VA - Class 1	VA - Class 3	Bbn 8012542	Order details			Weight 1 piece	Pack unit
						EAN	Type code	Order code		
100	1	-	1.5VA	3.5VA	807254	CT1M-S-30 100	2CSG280725R1000	0,83	1	
150	1	-	1.75VA	3.75VA	807353	CT1M-S-30 150	2CSG280735R1000	0,84	1	
250	1	-	3.75VA	6.25VA	807452	CT1M-S-30 250	2CSG280745R1000	0,86	1	
400	0.5	3.75VA	6.25VA	10VA	807551	CT1M-S-30 400	2CSG280755R1000	0,89	1	



CT1M-S-80

CT1M-S-80 .../5 A series, through primary										
Primary rated current (A)	Best Accuracy class	VA - Class 0.5	VA - Class 1	VA - Class 3	Bbn 8012542	Order details			Weight 1 piece	Pack unit
						EAN	Type code	Order code		
250	0.5	1VA	2.5VA	3.75VA	807650	CT1M-S-80 250	2CSG280765R1000	1,24	1	
400	0.5	2.5VA	3.75VA	5VA	807759	CT1M-S-80 400	2CSG280775R1000	1,27	1	
500	0.5	3.75VA	5VA	7.5VA	807858	CT1M-S-80 500	2CSG280785R1000	1,30	1	
600	0.5	5VA	7.5VA	10VA	807957	CT1M-S-80 600	2CSG280795R1000	1,32	1	
800	0.5	7.5VA	10VA	12.5VA	808053	CT1M-S-80 800	2CSG280805R1000	1,37	1	
1000	0.5	10VA	15VA	20VA	808152	CT1M-S-80 1000	2CSG280815R1000	1,42	1	



CT1M-S-120

CT1M-S-80 .../5 A series, through primary										
Primary rated current (A)	Best Accuracy class	VA - Class 0.5	VA - Class 1	VA - Class 3	Bbn 8012542	Order details			Weight 1 piece	Pack unit
						EAN	Type code	Order code		
800	0.5	7.5VA	10VA	12.5VA	808251	CT1M-S-120 800	2CSG280825R1000	1,65	1	
1200	0.5	15VA	30VA	45VA	808350	CT1M-S-120 1200	2CSG280835R1000	1,75	1	
1500	0.5	20VA	45VA	60VA	808459	CT1M-S-120 1500	2CSG280845R1000	1,83	1	

CT1M-S-30 Series

		max section [mm]
Through primary		
Cable	○	-
Horizontal bar	▭	-
Vertical bar	▭	33x23

CT1M-S-80 Series

		max section [mm]
Through primary		
Cable	○	-
Horizontal bar	▭	-
Vertical bar	▭	85x55

CT1M-S-120 Series

		max section [mm]
Through primary		
Cable	○	-
Horizontal bar	▭	-
Vertical bar	▭	125x85

Energy efficiency

CTA current transformers & TRF M modular current transformers



CTA/25

Standard type current transformers .../5 A with wound primary

CTA .../5 A series, wound primary with insertion on Ø8 MA bolt							
Primary rated current I _{prim} A	Accuracy class	Rated power VA	Bbn 8012542 EAN	Order details		Weight 1 piece kg	Pack unit pc.
				Type code	Order code		
10	0.5	5	661405	CTA/10	2CSG111030R1141	0.290	1
20	0.5	5	661603	CTA/20	2CSG111050R1141	0.290	1
25	0.5	5	661702	CTA/25	2CSG111060R1141	0.290	1
40	0.5	5	661801	CTA/40	2CSG111080R1141	0.290	1
50	0.5	5	661900	CTA/50	2CSG111090R1141	0.290	1
60	0.5	5	662006	CTA/60	2CSG111100R1141	0.290	1
80	0.5	5	662105	CTA/80	2CSG111110R1141	0.290	1
100	0.5	5	662204	CTA/100	2CSG111120R1141	0.290	1

CTA series

Wound primary		max section [mm]
Cable	○	8
Horizontal bar	▬	-
Vertical bar	▮	-



TRF M

Modular current transformers with Ø 29 mm through primary, secondary .../5A

TRF M are modular current transformers with through primary for measuring instruments. Their compact size and quick DIN rail plug allow easy installation along with great measurement precision.

Primary rated current I _{prim} A	Accuracy class	Rated power VA	Bbn 8012542 EAN	Order details		Weight 1 piece kg	Pack unit pc.
				Type code	Order code		
40	3	1	046912	TRFM/40	2CSM100050R1111	0.250	1
60	1	2	047018	TRFM/60	2CSM100070R1111	0.250	1
100	0.5	2	047117	TRFM/100	2CSM100090R1111	0.250	1
150	0.5	3	047216	TRFM/150	2CSM100100R1111	0.250	1
250	0.5	4	047315	TRFM/250	2CSM100120R1111	0.250	1
400	0.5	6	047407	TRFM/400	2CSM100140R1111	0.250	1
600	0.5	8	047506	TRFM/600	2CSM100160R1111	0.250	1

Energy efficiency

CT Current Transformers – Questions & answers

Can the incorrect installation of current transformers affect the measurement of the connected devices?

Certainly! Reversal of the connections to the secondary terminals or the wrong insertion of the primary cable can cause an incorrect measurement readings from the instrument.

If one of the above situations occurs, the instrument measures a secondary current on its terminals that flows in the opposite direction of what actually happens. This can lead to different consequences depending on how the firmware of the measuring device has been designed. A wrong connection in unidirectional instruments (reading on 2 quadrants) may be signaled by an error message.

On the other hand, it may not be signaled but cause an incorrect count of the instrument, or lead to the interruption of the measurement process. In bidirectional instruments (reading on 4 quadrants), this situation causes the imported power to be read as exported power and vice versa.

Is it necessary to earth the secondary terminals of the current transformers?

Earthing the secondary terminals of current transformers provides a reference towards earth in case of transformer failure, and prevents dangers for persons or risks of damage for the device installed in the switchboard. This does not affect the measurements made by ABB instruments, thus, when the wiring is being made, it is always recommended to comply with the indications in the instruction manual provided along with the measurement devices.

In practical terms, how does the accuracy of an energy meter and the respective current transformer affect the measuring chain, energy saving and efficiency evaluations?

To achieve Smart Metering, it is particularly important to know the accuracy class of an instrument in order to assess whether the accuracy of the measurement can be considered satisfactory. The importance of that can be understood analysing the practical example below.

Consider an installation with an average 100kW of energy consumption working 2,000 hours per year. To evaluate the accuracy of a metering unit composed by network analyser or energy meter, and current transformers, the propagation of error and its incidence on the final measure can be calculated with the following formula:

$$\varepsilon_E = \sqrt{\varepsilon_c^2 + \varepsilon_{ct}^2}$$

Where:

ε_E = percentage error of the energy measured

ε_c = percentage error of the energy meter

ε_{ct} = percentage error of the current transformer

The following table shows how the variation in the accuracy class of the measuring device and the associated current transformers affects the overall accuracy of the system.

	Example 1	Example 2	Example 3
ε_{ct}	0.5 %	1 %	2 %
ε_c	0.5 %	1 %	2 %
ε_E	0.71 %	1.41 %	2.83 %
Annual consumption measured with error	201.420 kWh	202.820 kWh	205.650 kWh
Overall cost of energy	0.18 €/kWh	0.18 €/kWh	0.18 €/kWh
Overall expense	36.256 €	36.507 €	37.017 €

The choice of an instrument with a higher degree of accuracy results in a measurement that is more accurate and with less chance of errors when consumption is assessed. The beneficial effect is that the more the error decreases the less will be the cost of energy. This is the reason why the standards governing the use of measuring instruments for billing applications (MID) prescribe the use of meters and current transformers whose accuracy must remain within a well defined range.



—
ABB Ltd.

ABB Electrification
Smart Buildings Division

solutions.abb/energyefficiencydevices