

ABB

**ABB AC Brushless Servodrives**

AC Brushless Servomotors Series 9C  
Installation and Use

**9C Servomotors Manual**





# AC Brushless Servomotors Series 9C

## **9C Servomotors Manual**

MANUM09 REV E  
EN

EFFECTIVE: 15.03.2008



# Safety Instructions

---

## Introduction

This chapter states the safety instructions that must be followed when installing an AC Brushless Servomotor of the 9C Series manufactured by ABB. The material in this chapter must be studied before attempting any work on, or with, the servomotor.

This chapter refers in particular to 9C Series Servomotors coupled with ABB ACSM1 Drive Modules, or with brushless drives in general.

## Warnings and Notes

This manual distinguishes two sorts of safety instructions. Warnings are used to inform of conditions that can, if proper steps are not taken, lead to a serious fault condition, physical injury and death. Notes are used when the reader is required to pay special attention or when there is additional information available on the subject. Notes are less crucial than Warnings, but should not be disregarded.

### Warnings

Readers are informed of situations that can result in serious physical injury and/or serious damage to equipment with the following symbols:



**WARNING! Dangerous Voltage:** warns of situations in which a high voltage can cause physical injury and/or damage equipment. The text next to this symbol describes ways to avoid the danger.



**WARNING! General Warning:** warns of situations that can cause physical injury and/or damage equipment by means other than electrical. The text next to this symbol describes ways to avoid the danger.

### Notes

Readers are notified of the need for special attention or additional information available on the subject with the following symbol:

**CAUTION!** **Caution** aims to draw special attention to a particular issue.

**Note.** **Note** gives additional information or points out more information available on the subject.

## General Safety Instructions



**WARNING!** The contents of this guide refer to 9C Series Servomotors correctly installed as described in this *Servomotors Manual*.

Only properly qualified electricians who are familiar with operation on Servomotors are allowed to perform the commissioning and operation activities of the Servomotors described in this Guide.



**WARNING!** For no reason should any person access the terminals of the servomotor, before at least eight minutes from the power outage of the drive system.

However this time strongly depends on the converter type connected to the motor.

Potentially lethal voltages may be present on the drive's intermediate DC circuit and the associated circuits, including the motors connected to the drive.



**WARNING!** The machine manufacturer, who commissions the servomotor, must install proper additional protection functions to avoid damages to health or equipment when the machine is operating.



Neglecting these instructions can cause physical injury and death. More Warnings and Notes are printed at appropriate instances along the text.

# Table of Contents

---

<b>Safety Instructions</b> .....	<b>5</b>
Introduction .....	5
Warnings and Notes.....	5
Warnings .....	5
Notes .....	5
General Safety Instructions .....	6
 <b>Table of Contents</b> .....	 <b>7</b>
 <b>Introduction to this Manual</b> .....	 <b>11</b>
Introduction .....	11
Before You Start.....	11
What This Manual Contains .....	11
Related Publications .....	11
Terminology .....	12
ServoDrive .....	12
DE and NDE .....	12
Rights.....	12
 <b>9C Servomotors</b> .....	 <b>13</b>
Introduction .....	13
Main characteristics .....	13
Motor Plate .....	13
Insulation System.....	14
Cooling .....	14
Type of Construction.....	14
Protection Degree.....	15
IP protection in IM V3 or IM V19 configuration .....	15
Definition of IP protection degree.....	16
Radial oil seal .....	17
Dimension Drawing of the Radial Oil Seal.....	17
Installation of the Radial Oil Seal .....	18
Position Transducer .....	20
Temperature Sensor .....	20
Brake (option) .....	21
Overall dimensions.....	23
9C1 Overall Dimensions .....	24
9C4 Overall Dimensions .....	25
9C5 Overall Dimensions .....	26
Other characteristics .....	27
Motors' Weights .....	27
Storage.....	27
Operating Conditions .....	27

---

<b>Mechanical Installation .....</b>	<b>28</b>
Introduction .....	28
Usage notes.....	28
Bearings .....	28
Loads on drive end motor shaft .....	28
Bearings specs .....	28
Pulleys and couplings .....	29
Mounting according to IMVx configuration .....	29
<b>Electrical Installation .....</b>	<b>30</b>
Introduction .....	30
Safety.....	30
Connection to the motor assembly .....	31
Power Connections.....	32
Signal Connections.....	33
<b>Servomotors Data .....</b>	<b>34</b>
Introduction .....	34
9C Series Servomotors Data.....	34
Servomotor Size 9C1 .....	35
Operating Curves.....	36
N 503001 - Size 9C1.1 .....	36
N 503002 - Size 9C1.2 .....	36
N 503003 - Size 9C1.3 .....	37
N 503004 - Size 9C1.4 .....	37
Servomotor Size 9C4 .....	38
Operating Curves.....	39
N 503005 - Size 9C4.1 .....	39
N 503006 - Size 9C4.2 .....	39
N 503007 - Size 9C4.3 .....	40
N 503008 - Size 9C4.4 .....	40
Servomotor Size 9C5 .....	41
Operating Curves.....	42
N 503010 - Size 9C5.2 .....	42
N 503011 - Size 9C5.3 .....	42
N 503012 - Size 9C5.4 .....	43
N 503013 - Size 9C5.5 .....	43
N 503014 - Size 9C5.6 .....	43
<b>Appendix A – Motor Code .....</b>	<b>44</b>
<b>Appendix B – Standards and Safety .....</b>	<b>46</b>
Introduction .....	46
Norm References .....	46
Standards .....	46
Electromagnetic Compatibility (EMC) Directive .....	47
Low Voltage Directive .....	47
Compliance with EEC Directives and CE Marking.....	48
Restricted Distribution.....	48
Mounting and Installing Instructions .....	48

Compliance of the Drive Systems with the Directives.....	48
Note for the Application of Other EEC Directives .....	48
Safety Instructions.....	49
Meaning of the Symbols.....	49
Installation and Operation .....	49
Dangerous Temperature.....	49
Application Guidelines for Electromagnetic Compatibility .....	50
Electric System .....	50
Customer Service .....	51

This page is intentionally left blank.

# Introduction to this Manual

---

## Introduction

This document *Servomotors Manual* is intended for installation, commissioning and use of the AC Brushless 9C Series Servomotors manufactured by ABB - Line S, Italy. These electric motors are intended to be coupled with ACSM1 Drive Modules, provided by ABB. Therefore the documentation of the ACSM1 Drive Modules must be studied before attempting any work on, or with, the motors.

In any case, since 9C Servomotors can be used also with different brushless drives, the manuals of the drive used must be studied before attempting any work on, or with, the motors.

## Before You Start

The reader is expected to have an appropriate knowledge of electrical fundamentals, electrical wiring practices and, in general, of drive systems, i.e. motors and converters.

## What This Manual Contains

The aim of this manual is to provide the reader with all the necessary information for a proper installation of the servomotors, both mechanical and electrical.

*Safety Instructions* are featured in the first few pages of this Manual. Safety Instructions describe the formats for various warnings and notations used within this Manual. Other instructions are given along the present document.

*Introduction to this Manual*, contains a short description of this Manual.

*9C Servomotors*, describes the main characteristics of the servomotors, the main components and accessories.

*Mechanical Installation*, shows how to deal with mechanical installation of the servomotors.

*Electrical Installation*, shows how to deal with electrical installation of the servomotors.

*Servomotors Data*, shows the main parameters, operating curves and electromechanical data of the servomotors.

*Appendix A – Motor Code*, describes the coding method used to identify the servomotors.

*Appendix B – Standards and Safety*, lists the norms that the motor complies to, that have been used in design and must be followed in installation.

## Related Publications

In addition to this manual please consult the *Servomotor Variants Manual*, if you need to find special options not listed here.

If you need information about the drive to be coupled with these servomotors, please consult the complete user documentation of ACSM1 Drive Modules.

## Terminology

Listed below are the terms and conventions which have special meaning throughout this Manual.

### **ServoDrive**

A Servodrive is a system made of a servo converter coupled with a servomotor.

### **DE and NDE**

According to IEC 60034-7, the two ends of a motor are defined as follows:

DE: Drive End of the motor

NDE: Non Drive End of the motor

On the DE typically the shaft has its extension to transmit the torque to a load. On the NDE of the 9C Servomotors is typically mounted the position transducer. The optional parking brake of the motor is mounted on the DE side.

## Rights

ABB works on a policy of continuous improvement of products performances to gear the market demand, as well as of the marketing and technical documentation. Therefore all the materials and technical data contained in this manual are subjected to changes without notice.

Up-to-date documentation is available online on the websites [www.abb.com/ProductGuide](http://www.abb.com/ProductGuide) , weblink Motors.

# 9C Servomotors

## Introduction

This chapter gives general information on the AC Brushless Permanent Magnet Servomotors of the 9C Series manufactured by ABB - Line S. The main characteristics, components and accessories of the 9C Servomotors are here described.

## Main characteristics

9C Servomotors are electrical machines manufactured according to IEC 60034-1 standard.

9C Series Servomotors are brushless, rare earth permanent magnet (Neodymium, Iron, Boron), 10 poles, extremely compact, high performance servomotors with innovative concentrated windings stator core.

The motors are equipped with:

- a brushless/frameless resolver, or alternatively, an absolute multi-turn encoder (integrated into the servomotor)
- a temperature sensor (integrated into the servomotor)

A mechanical parking brake integrated into the motor can be mounted as an option.

## Motor Plate

The main electrical data and manufacturing information are stated on the servomotor plate fixed sideways on the motor back-flange.

1. Stall Current "**I<sub>o</sub>**" and Rated Current "**I<sub>n</sub>**"
2. Peak Current "**I<sub>p</sub>**"
3. Stall Torque "**T<sub>o</sub>**" and Rated Torque "**T<sub>n</sub>**"
4. Peak Torque "**T<sub>p</sub>**"
5. Rated Power "**P<sub>n</sub>**"
6. Nominal Frequency "**f<sub>n</sub>**"
7. Rated Speed "**N<sub>n</sub>**"
8. Back-emf voltage at rated speed "**B<sub>emf@N<sub>n</sub></sub>**"
9. Position transducer type
10. Brake Type (if present): DC Voltage supply "**V**"; current "**A**" in Amperes; Static holding torque "**Nm**"
11. Serial number "**S/N**" and "Code 128" bar code
12. Motor "**Type**" code and type bar code
13. IP protection degree of the motor body
14. Insulation class
15. Markings: CE, UL etc.
16. Manufacturing date
17. Manufacturing Country



## Insulation System

9C Servomotors are manufactured with an innovative resin insulation process that guarantees increased dielectric strength and high resistance to voltage spikes, especially in demanding application with frequency converters.

Overall the windings are manufactured according to insulation class F, that is maximum windings temperature 155°C with maximum ambient temperature 40°C.

**Note.** For the best use of 9C Servomotors, it is recommended not to exceed an operating temperature of 140°C. Note also that the best motor performances are obtained at low temperature (for example, windings temperature 90°C); hence, the installer can arrange for additional surface cooling and ventilation in order to improve the motor thermal dissipation.

## Cooling

9C Series Servomotors are air cooled by natural circulation. Allowed cooling medium is open Air. Different medium are not allowed, in particular liquids and explosive gases.

According to IEC 60034-6 9C Servomotors are identified by the code IC0041 that means closed motor, surface cooled without fan.

## Type of Construction

Electric motors are classified according to the definition of the IM Code in IEC 60034-7. The general definition of the IM Code is:

- IM B... for horizontal shaft
- IM V... for vertical shaft

Standard 9C Servomotors allow flange installation, horizontal shaft (mounting configuration IM B5). Up to certain extent they can also be used for vertical mounting. For a detailed description of limitations and prescriptions, see the related chapter *Mechanical Installation*.

Upon request, the servomotors can be manufactured in other mounting configurations.

The practical meaning of various mounting configuration is provided below.

IM B5 Flange mounted with passing holes on the flange, horizontal.

IM V1 Flange mounted with passing holes on the flange, vertical, shaft down.

IM V3 Flange mounted with passing holes on the flange, vertical, shaft up.

IM B14 Flange mounted with tapped blind holes on the flange, horizontal.

IM V18 Flange mounted with tapped blind holes on the flange, vertical, shaft down.

IM V19 Flange mounted with tapped blind holes on the flange, vertical axis, shaft up

## Protection Degree

9C Series Servomotors are protected according to IEC 60034-5.

For standard 9C Servomotors with power and signal connectors the IP protection degree is:

- IP65 on the motor body, IP54 on DE shaft-end

The motor body can reach IP67 protection degree by special arrangements.

For the shaft end (Drive end side) the degree of protection is:

- IP54 without oil seal
- IP64 with oil seal installed

This standard degree of protection is valid for servomotors mounted according to configuration IM B5.

Note that if the flange mounting of the motor is such to prevent the leakage of fluids towards the shaft drive end, for example by means of O-rings, than the protection degree of the DE is the same of the motor body.

**Note.** Despite the protection degree and the possible insertion of seals, 9C Servomotors are intended for use indoors, in dry and dust free environments. For the best use of 9C Servomotors and regular lifetime with little maintenance, it is a good practice to keep the installation site dry and clean.

### *IP protection in IM V3 or IM V19 configuration*

Mounting according to configuration IM V3 or IM V19 is possible upon request. In these configurations the protection degree on the shaft drive end can be dramatically lowered, both in case of motor without oil seal and in case of standard oil seal.

Despite 9C motors are provided with sealed bearings it is practically impossible to prevent dangerous fluids entering the motor on the shaft drive end, unless particular special oil seal are used.

To guarantee a protection level IP x5-x7 in mounting configuration IM V3 or IM V19 it is therefore necessary to use special oil seals, not mounted in the standard motor design.

In these cases please contact ABB Customer Service.

### Definition of IP protection degree

According to the definitions in IEC 60034-5, the protection degree is indicated by the IP letters followed by two numerals. The first numeral indicates the degree of protection given by the enclosure to both people and motor itself; in particular the objects, tools, wires, that, handled by a person can enter into the motor or, in case they enter the motor they do not cause damages to the motor itself, are indicated.

First numeral	Description	Examples of things from which the motor is protected
0	Non protected motor	No particular protection.
1	Motor protected by solid objects having dimensions greater than 50 mm	For example parts of the body like hands or objects with dimensions greater than 50 mm cannot contact or enter into the motor or close to live parts, either accidentally or inadvertently.
2	Motor protected by solid objects having dimensions greater than 12 mm	For example parts of the body like fingers or objects like screwdrivers with length greater than 80 mm or objects with dimensions greater than 12 mm cannot contact or enter into the motor or close to live parts.
3	Motor protected by solid objects having dimensions greater than 2.5 mm	For example objects like small tools, wires or objects with dimensions greater than 2.5 mm cannot enter into the motor or close to live parts.
4	Motor protected by solid objects having dimensions greater than 1 mm	For example objects like wires, strips of 1 mm thickness, or objects with dimensions greater than 1 mm cannot enter into the motor.
5	Motor protected by the dust	Some dust can enter into the motor but its amount does not compromise the correct operation of the motor.
6	Motor totally protected by the dust	No dust can enter into the motor at all.

The second numeral indicates the degree of protection offered by the enclosure to prevent the dangerous effects of the penetration of water into the motor.

Second numeral	Description	Examples of things from which the motor is protected
0	Non protected motor	No particular protection.
1	Motor protected from water drops	The vertical drops of water.
2	Motor protected by water drops until tilted at 15°	Vertical drops until the motor is tilted up to 15° in any direction different than its normal position.
3	Motor protected from sprayed water	Water sprayed against the motor up to 60° from the vertical direction.
4	Motor protected from splashed water	Water splashed onto the motor from any direction.
5	Motor protected from water jets	Water jets created by a nozzle in any direction.
6	Motor protected by powerful jets	Water created by powerful jets or by sea waves.
7	Motor protected by the immersion	Water cannot enter when the motor is submersed according to predefined conditions
8	Motor protected by the effects of a prolonged immersion	A prolonged immersion in water under specified conditions, for example because the motor is totally sealed or because if the water enters it does not create damages.

## Radial oil seal

All 9C series servomotors are mechanically arranged to allow for a radial oil seal on the rotating shaft; in the standard version, this oil seal is not mounted but, upon request, it may be included in the motor shipping.

The oil seal provided by ABB is made of Viton material.

As an alternative the Customer may ask that the oil seal is mounted in factory. For this option see the *Servomotors Variants Manual*.

The radial oil seal mounted on the drive end side improves the capacity of the shaft end to withstand leakage of fluids into the motor, in particular oil. Therefore the radial oil seal has the function to protect the motor insulation and the permanent magnets from potentially dangerous fluids.

The IP protection degree of 9C servomotors without oil seal installed is IP54 for the shaft-end. Installing the oil seal improves the IP protection degree of the motor shaft end to IP64.

The oil sealer shall be installed **only** if the motor shaft and the oil sealer itself are actually wet by oil.



If lubricating fluids other than common mineral and synthetic oils are used and in case of over-pressure of these fluids, contact ABB before operation.



Avoid mounting the oil seal if dry operation is foreseen: the material of the device will be quickly damaged and worn out, creating dust and likely damaging the bearing itself.



If the radial oil seal is installed, when cleaning the shaft-end use cleaning products compliant with the material of the oil seal installed. Non-conformal, corrosive or abrasive products will cause a decay of the oil seal properties and cause impurities to seep into the motor.

### Dimension Drawing of the Radial Oil Seal

The figure below shows the dimension drawing of the radial oil seal included in the shipping of 9C Servomotors.

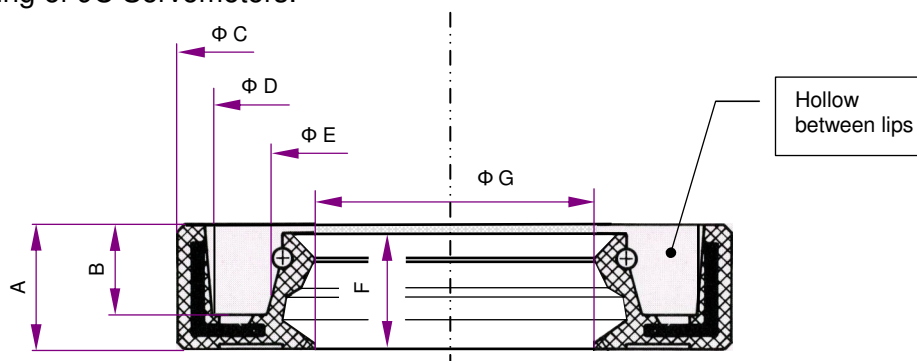

Motor Code	A	B	C	D	E	F	G
9C1	7	5	35	32	29	6	25
9C4	5	3,3	42	38,5	35,5	4,5	30
9C5	7	5,2	62	57	44	6,3	40

### Installation of the Radial Oil Seal

The oil seal provided with 9C servomotors is a double-lip ring with an internal spring. The flexible lips rub against the shaft to prevent the leakage of fluids and dirt, while the spring of the inner lip helps to keep the lip in contact with the shaft.

The efficiency and duration of the oil seal are strictly connected to the preservation of its physical and mechanical characteristics. Incorrect installation or incorrect operation of the oil seal can lead to deterioration of its properties and hence to motor failure.

Therefore, when mounting the radial oil seal carefully observe the following rules to assist the installation.

- The oil sealer must be installed vertically centered over the shaft absolutely avoiding stress, sliding frictions and consequent deformation. Therefore it is then recommended to prepare an installation tool according to the following illustration.

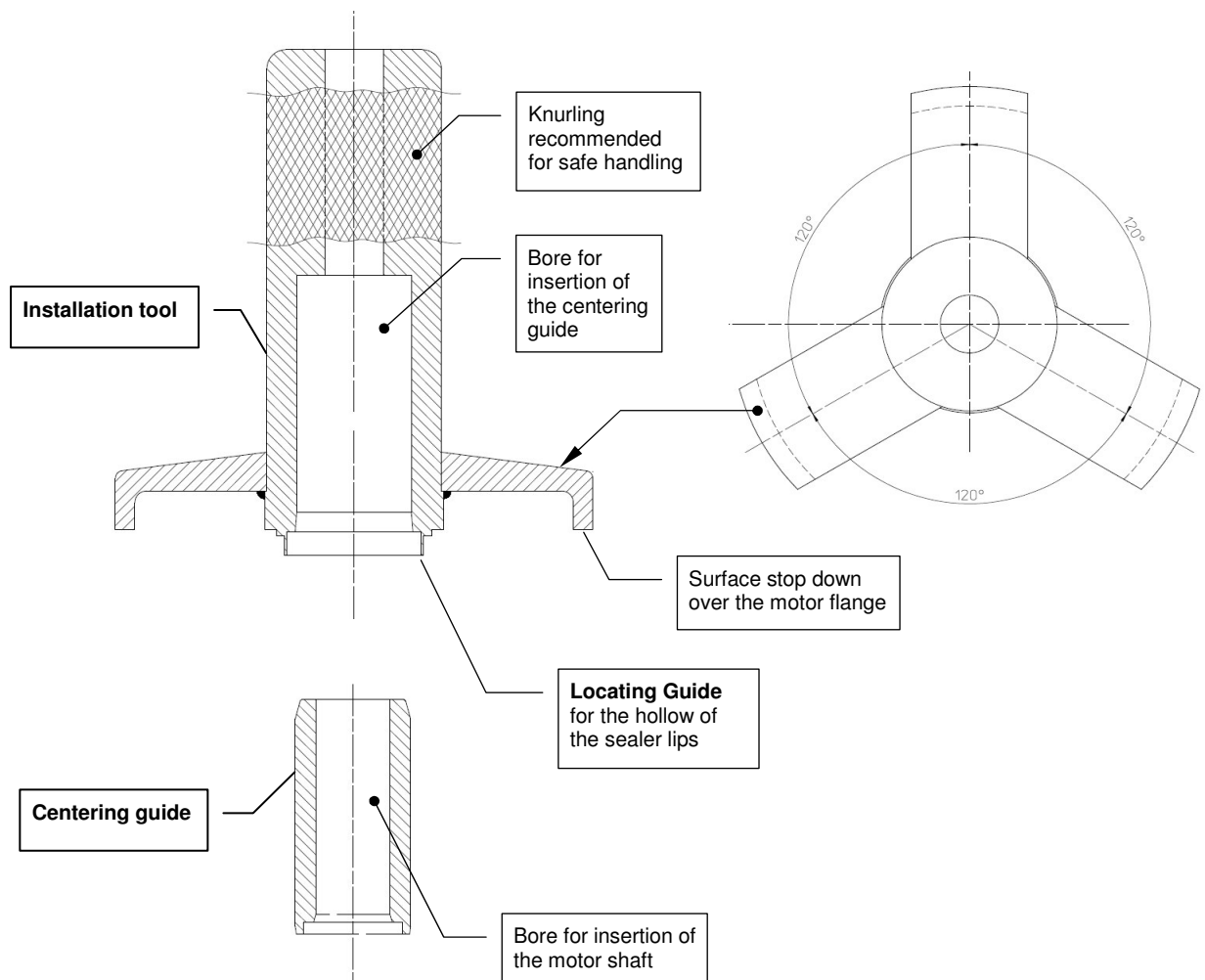

**Note.** Overall dimensions of the installation tool and centering guide must be compliant with dimension of the shaft end and radial oil seal used.

- Lay down the motor vertical, shaft up.
- Grease the radial oil seal with common mineral grease.
- Insert the oil seal vertically centered over the centering guide. The seal lips must be oriented in the direction of the leakage fluid, i.e. lips and hollow up toward the installer.

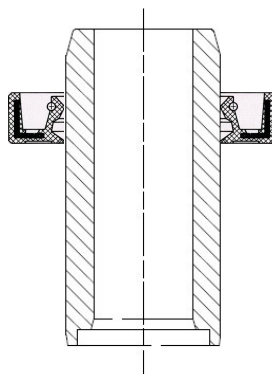

- Then install the centering guide over the motor shaft, down to stop.
- Insert the locating guide of the installation tool into the oil seal hollow and push the installation tool down to stop. **Absolutely avoid to force the tool and the oil seal. Absolutely avoid forces or sliding friction that might deform the lips** or dislodging the inner contact spring. The contact surface of the lips must keep smooth and keep the integrity overall.

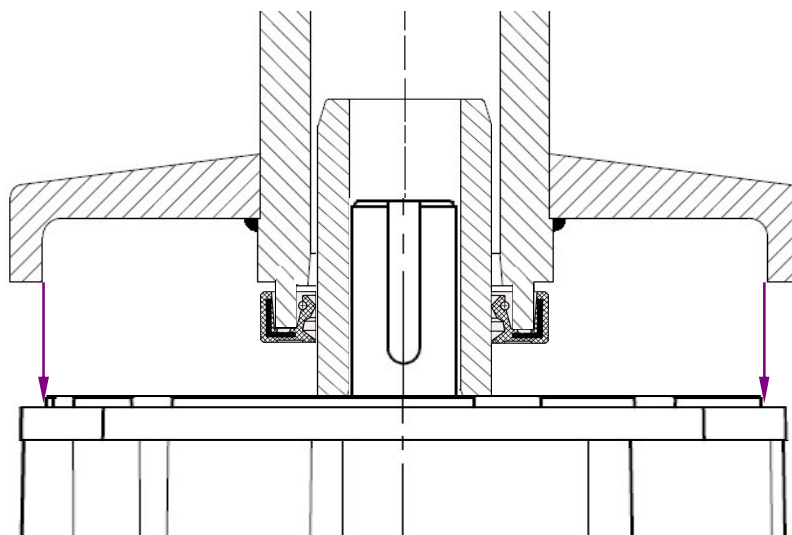

- Check that the surface of the installation tool is stopped down over the motor flange and centered on the flange centering diameter. If so, the radial oil seal is correctly installed; the installation tool and the centering guide can be now removed.

### Position Transducer

9C brushless servomotors can be equipped with one of the following position transducer types:

- Resolver size 15, 2 poles
- Heidenhain encoders of the Series EQN1325, 512 pulses/turn

The position transducer is mounted on the motor NDE-side.

For other types of position transducers agreements with the Sales department and the factory must be taken. Contact ABB – Line S, Customer Service for further details and ordering options.

### Temperature Sensor

The Servomotors embody a temperature sensor of PTC type. This thermal sensor provides information to the control circuits on the motor temperature. Therefore this device must be connected to the servo converter before operation, and proper alarm levels must be set on the converter control circuits in order to prevent motor overheating and failure.

The PTC signals are connected to the converter through the signal cable. Omitting the connection of the thermal sensor inhibits the servodrive operation.

PTC sensors are temperature sensitive semiconductor resistors. The change of resistance vs. temperature is the information used from the control circuit to handle alarms on current levels and to avoid overheating of the motor.

The typical temperature-resistance diagram of the PTC used in 9C Servomotors is here illustrated.

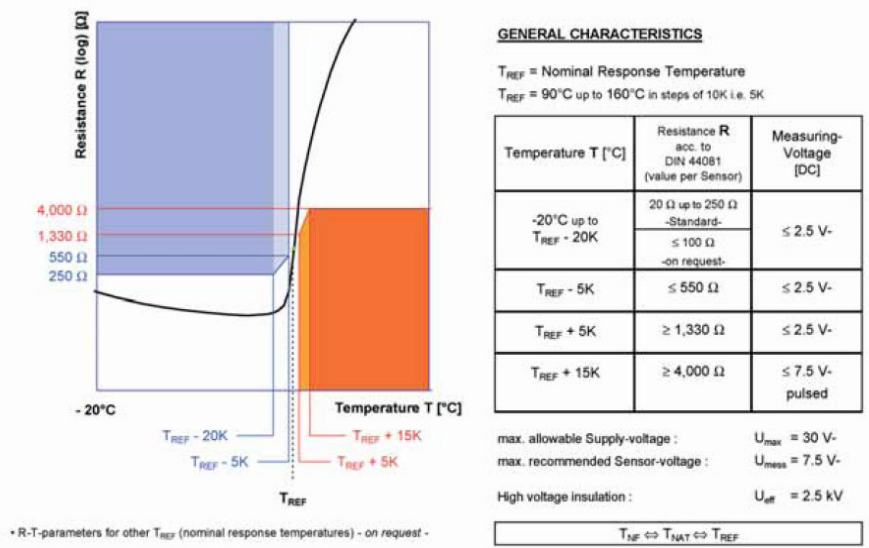

For protection of the motor against overheating and consequently derating of the torque performances, the temperature tripping level of the converter control circuit is usually set to 140°C with ± 5°K tolerance range.

As an option, upon request, 9C Servomotors can be provided with a thermal switch, instead of the thermal sensor, or with different customer specific thermal sensors. For these options please contact ABB – Line S.

## Brake (option)

For particular applications, the motor can be arranged with an electrically driven brake that mechanically acts on the servomotor shaft; when mounted, the brake is fully integrated into the motor structure.

Do not confuse this mechanical-action brake with the braking electronic unit of the converter circuit, allowing dissipation of electric regenerated power on a resistor.

The servomotor's brake can be considered as a "parking and emergency brake"; its main function is to lock the motor shaft when the converter is discharged and to brake in emergency cases. It must not be used for stopping the drive in normal operation.

In case of axial loads on the motor shaft, please contact the Customer Service before operation.

The servomotor can be provided with spring-applied mechanical brake.

Brakes work with reverse logic, i.e. shaft-end unlocked when supplied with 24 VDC voltage; locked when discharged.

In 9C Servomotors, the insertion of a mechanical brake results in a different length of the servomotor. Exception to this are 9C5 servomotors, where the brake does not change motor length.



Since brakes are typically disc brakes they are very sensitive to axial movements of the shaft.

Therefore, for servomotors equipped with brakes, if axial loads are foreseen, please contact our Customer Service.

Frame	Technical data of the mechanical brakes Tolerance: $\pm 10\%$		
	Power Consumption at 20 degrees centigrade (W)	Brake Voltage (Vdc)	Brake Static Torque (Nm)
9C1	6,3	24	2,5
9C4	19,5	24	16
9C5	28,0	24	32

When the brake option is present, the connection must be performed observing the following.



The brake management is fully under care and responsibility of the installer and manufacturer of the electrical control cabinet. The brake is a safety brake and so it is **operating (i.e. it brakes) when it is not powered**.

It is therefore mandatory to power the brake, i.e. unlock the motor shaft, before powering the motor itself; so the logic of the electrical control cabinet must provide a timely and adequate power supply to the brake, also checking that the brake is continuously powered during the servomotor operation.

**Note.** The brake shall be powered by **DC current**, coming from a separate power supply having adequate power and the specified voltage tolerance.

## Overall dimensions

The overall dimensions drawings of 9C Series servomotors are shown in the following, both for the version with resolver transducer and encoder transducer, and the optional brake.

Note. The motor code 9Cx.x.xx (or better, the motor assembly code) is made of a combination of letters and/or digits.

- the first two digits (**9C**) indicate the series,
- the third digit indicates the axis height (**1, 4, 5**, etc.),
- the fourth indicates the motor size (**1, 2, 3, 4**, etc.) related to axial length,
- digits five-six indicate the motor nominal speed: **30** for 3000 rpm, **40** for 4000 rpm, **60** for 6000 rpm.

The overall dimension drawings given below offer an overview of each servomotor frame type 9C1, 9C4 and 9C5. Actual dimension drawings are different according to the motor frame, size, accessories and options, such as the transducer and the brake.

Overall dimension drawings for any motor design and mounting configuration are available. Contact ABB – Line S, for details.

### 9C1 Overall Dimensions

The following figure and dimension table show the overall dimension of the 9C1 Servomotors. Note that the dimension drawing refers to a servomotor frame 9C1, size 1, with brake and encoder.

All the motors are supplied with half-key inserted and full-key in package.

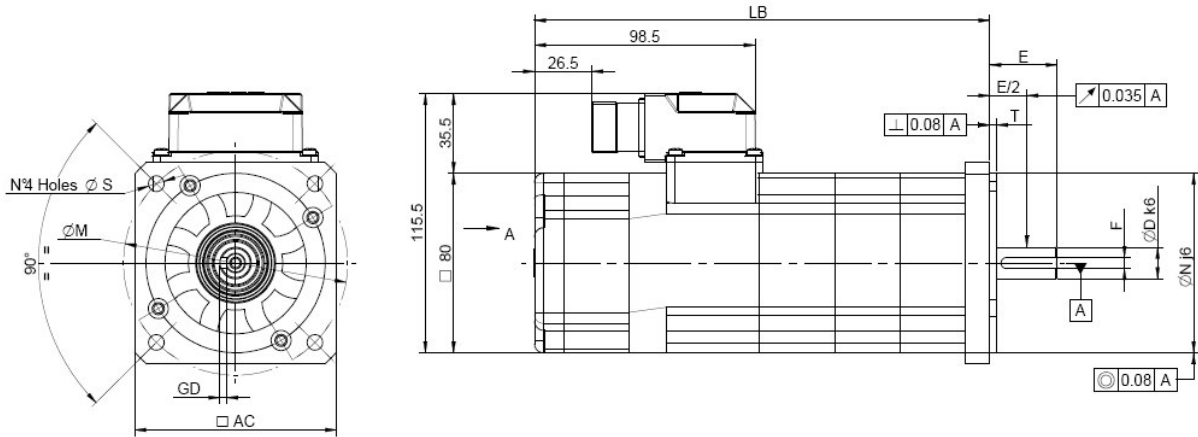

Frame	Motor Base Length				Front Flange - Shaft End								
	LB Resolver	LB Encoder	LB Resolver + Brake	LB Encoder + Brake	Flange F100					D-END			
					N	M	S	AC	T	D	E	F	GD
9C1.1.xx	142	171	171	200	80	100	7	90	3	14	30	5	3
9C1.2.xx	176	205	205	234	80	100	7	90	3	14	30	5	3
9C1.3.xx	210	239	239	268	80	100	7	90	3	14	30	5	3
9C1.4.xx	244	273	273	302	80	100	7	90	3	14	30	5	3

## 9C4 Overall Dimensions

The following figure and dimension table show the overall dimension of the 9C4 Servomotors.

Note that the dimension drawing refers to a servomotor frame 9C4, size 1, with encoder and no brake.

All the motors are supplied with half-key inserted and full-key in package.

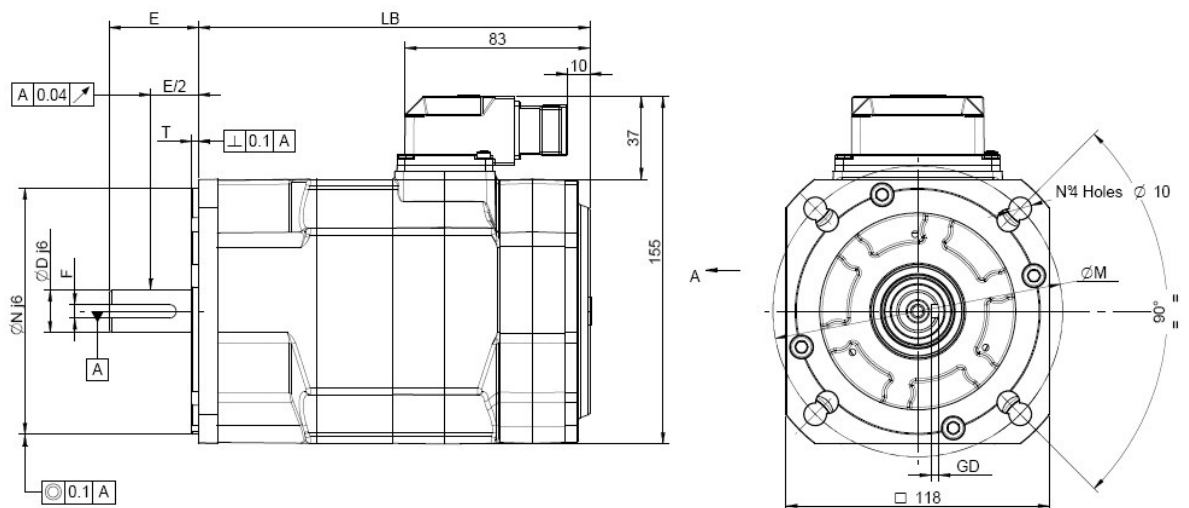

Frame	Motor Base Length				Front Flange - Shaft End						
	LB Resolver	LB Encoder	LB Resolver + Brake	LB Encoder + Brake	Flange F115			D-END, Key type UNI6604 – 6X6X30			
					N	M	T	D	E	F	GD
<b>9C4.1.xx</b>	146	175,5	175,5	205	95	115	3	19	40	6	3,5
<b>9C4.2.xx</b>	180	209,5	209,5	239	95	115	3	19	40	6	3,5
<b>9C4.3.xx</b>	214	243,5	243,5	273	95	115	3	19	40	6	3,5
<b>9C4.4.xx</b>	248	277,5	277,5	307	95	115	3	19	40	6	3,5

### 9C5 Overall Dimensions

The following figure and dimension table show the overall dimension of the 9C5 Servomotors.

Note that the dimension drawing refers to a servomotor frame 9C5, size 2.

The 9C5 motor base length is the same with resolver or encoder, and with or without brake.

All the motors are supplied with half-key inserted and full-key in package.

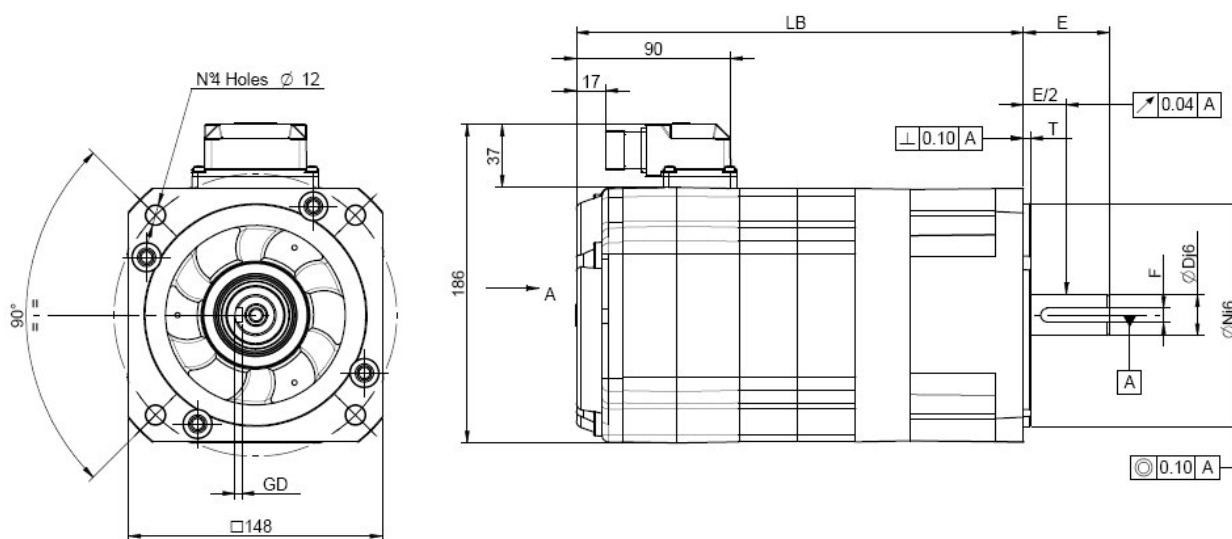

Frame	Base Length	Front Flange - Shaft End							
		Flange F165			D-END		Key type		
	LB	N	M	T	D	E	F	GD	UNI6604
9C5.2.xx	261	130	165	3,5	24 j6	50	8	4	8X7X40
9C5.3.xx	295	130	165	3,5	24 j6	50	8	4	8X7X40
9C5.4.xx	329	130	165	3,5	24 j6	50	8	4	8X7X40
9C5.5.xx	363	130	165	3,5	24 j6	50	8	4	8X7X40
9C5.6.xx	397	130	165	3,5	24 j6	50	8	4	8X7X40

## Other characteristics

### Motors' Weights

The actual weight of each servomotor depends on size, mounting arrangements and additional equipment integrated into the motor.

The following table shows the average weights of the motors in their standard versions.

Frame	Size	Motor code	Weight [kg]	Weight with brake [kg]
<b>9C1</b>	1	9C1.1	3.0	3.5
	2	9C1.2	3.9	4.4
	3	9C1.3	4.8	5.3
	4	9C1.4	5.7	6.1
<b>9C4</b>	1	9C4.1	4.1	5.2
	2	9C4.2	7.0	8.1
	3	9C4.3	9.9	11.0
	4	9C4.4	12.8	14.9
<b>9C5</b>	2	9C5.2	16.0	19.2
	3	9C5.3	20.0	23.2
	4	9C5.4	24.0	27.2
	5	9C5.5	28.0	31.2
	5	9C5.5	28.0	31.2
	6	9C5.6	32.0	35.2

### Storage

The motors should always be stored indoors, in dry, vibration free and dust free environments. Ambient temperature for storing is -30 °C to 85 °C.

If long storing is foreseen, supply the brake if present and run slow the motor periodically for a short run-in until free smooth rotation is achieved.

### Operating Conditions

Ambient temperature allowed for operation is 0 ÷ 40 °C. The maximum ambient temperature allowed is 50 °C.

A derating of the motor electrical performance is mandatory in the range 40 °C to 50 °C. The derating rate is 1% / °C.

Maximum altitude for the installation is 1000 m.a.s.l.

# Mechanical Installation

## Introduction

This chapter provides information on mechanical installation of the AC Brushless Servomotors manufactured by ABB S.p.A.

## Usage notes

A particular care from the mechanical point of view must be devoted when using any kind of servomotor.

### Bearings

Since the most delicate part of a servomotor are bearings and shaft, information on mounting constraints and on the usage of the coupling of the motor to its load though the drive end shaft will be in particular given.

On the other hand, for what concerns mounting of the motor to the mechanical body of the machine there are not particular instructions or recommendations, but the normal professional competence of the installer.

For the best use of 9C Series servomotors, table below indicates axial and radial loads for each servomotor, which must not be exceeded in order to guarantee a regular lifetime of 20,000 hours in continuous duty of the bearings with permanent lubrication. In general, the locked bearing is mounted on the motor front-side. The configuration related to the load application is shown in figure.

#### Loads on drive end motor shaft

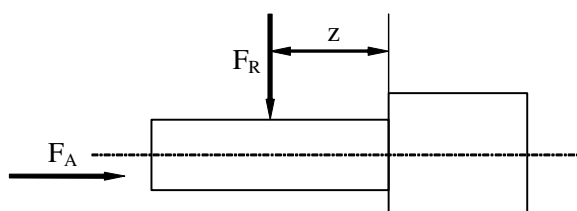

#### Bearings specs

Servo motor	speed [rev/min] $n_N$	Bearing type Sealed		Radial load $F_R$ [N] @ $n_N$	Axial load $F_A$ [N] @ $n_N$	Dist. [mm] z
		DE side	NDE side			
9C1	3000	6004-C3	6001-C3	375	240	20
9C4	3000	6205-C3	6204-C3	630	350	20
9C5	3000	6207-C3	6205-C3	1200	650	25

**Note.** Values for simultaneous axial stresses are available on request.  
Values for versions with integrated brake (special versions) are available on request.

**Note.** The permissible axial load values refer to the  $F_A$  force direction towards the motor; for reverse direction a reduction is necessary (values are available on request).



Taking into consideration the foreseen duration,  $F_R$  radial loads must not exceed the values indicated, even for a transient period (accelerations, decelerations).

In particular, shocks caused, for example, by the assembling of mechanical parts (couplings, keys, nuts, etc.) on the shaft end are not allowed.

#### *Pulleys and couplings*

Couplings, sheaves and pinions must be assembled using adequate tools, **absolutely avoiding the use of a hammer**, which could cause serious damage to the motor.

Once the assembly has been completed, the shaft should be greased in order to avoid oxidation.

#### *Mounting according to IMVx configuration*

In vertical mounting due to the different kind of mechanical loads, due to the vertical forces acting on the motor, it is necessary to consider the effect of these loads on the bearings life.

In these cases ABB recommends to contact the Customer Service.

# Electrical Installation

---

## Introduction

This chapter gives information on how to perform electrical installation of the AC Brushless 9C Series Servomotors.

## Safety

**WARNING!**

Electrical installation must be carried out only by skilled persons.

Carefully observe the international safety standards.

**WARNING!**

Electrical installation includes preparation and layout of the power and signal cables, observing the safety requirements, insulation distances, grounding of the machine, and compliance to EMC standards.

**WARNING!**

Before any operation of electrical installation or maintenance switch off both power and auxiliary supply of the drive.

**Note.** It is recommended to perform the installation of the motor observing the grounding and cabling instructions required by the frequency converter.

## Connection to the motor assembly

All power and signal connections to the motor assembly are indicated in this paragraph.

9C Series Servomotors are provided with a connection box that includes a power connector (8 pins) and a signal connector (17 pins).

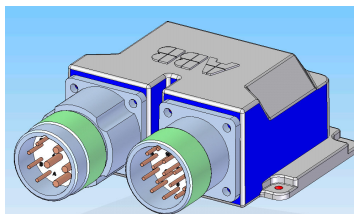

**Note.** Both power and signal cable connectors must be securely tightened to their respective connectors on the motor, to ensure proper electrical connection and avoid risk of loosening due to vibrations. Pre-assembled power and signal cables are available. Special cables can be manufactured as well. For information contact ABB - Line S, Sales Office.

## Power Connections

The motor power connections are as follows:

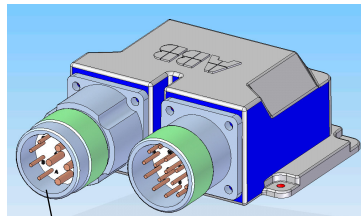

8-Pins Power Connector

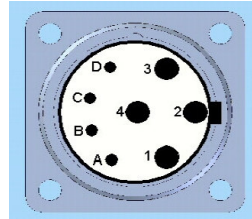

Pin	Signal
3	Phase U
1	Phase V
4	Phase W
2	
A	Brake +
B	Brake -
C	-
D	-

For the route between the electrical control cabinet and the motor, it is recommended to use a shielded four-pole cable (three-phases + yellow-green), with appropriate cross section for the converter output rated current.

For these connections it is also possible to use metal sheath cables.

In any case, the external shield must be connected to the motor earth.

**Note.** When preparing the installation strictly observe the provisions of Appendix B, *Application guide to electromagnetic compatibility*, and the installation guidelines of the frequency converter.



### WARNING!

In general, for any kind of converter, it is mandatory to observe the correspondence of the U-V-W connections between motor and converter.

The exchange of phases prevents the drive system from operating.



### WARNING!

When connecting the motor brake, if present, the polarity of the power supply must absolutely be respected.

## Signal Connections

The signal connector of the position transducer is a standard 17-pins male connector for industrial application integrated into the connection box.

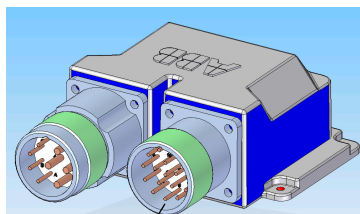

17-pins signal connector

Standard 9C Servomotors are equipped either with a resolver transducer, or with an encoder transducer at customer's choice.

Pin-out of the 17-pins connector is standardized as follows, for any type of resolver or encoder installed.

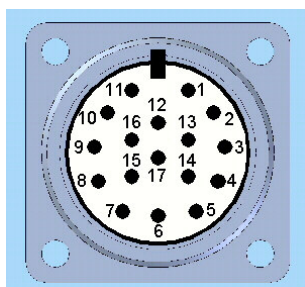

Pin	Resolver Signal	ENDAT EQN 1325 Encoder Signal
1	S1 (Cos+)	Sensor
2	S2 (Sin+)	-
3	S3 (Cos-)	-
4	S4 (Sin-)	Sensor
5	Thermal sensor	Thermal sensor
6	Thermal sensor	Thermal sensor
7	R1 (Supply+)	Up
8	R2-R3 (Supply-)	CLOCK
9	-	CLOCK -
10	-	0V
11	Internal shield	Internal shield
12	-	B +
13	-	B -
14	-	DATA +
15	-	A +
16	-	A -
17	-	DATA -



### WARNING!

Wrong wiring of the signal connections can cause malfunctioning that seriously compromise the operation of the drive system with risk of physical injury and/or damage to the equipment!

Preassembled signal cables are available upon request complete with right connectors both on the motor assembly side and on the drive side. These cables can be purchased together with the drive system. Consult the Product Catalogue or contact the Sales Office for ordering codes.

# Servomotors Data

---

## Introduction

This Chapter provides information on ratings, electrical data and performance of the 9C Series Servomotors.

## 9C Series Servomotors Data

Electrical and performance data of the following tables, as well as operating curves of peak and continuous torque, refer to servomotors of 400VAC nominal supply voltage.

## Servomotor Size 9C1

Data and operating curves of the 9C1 servomotors, size 1, 2, 3 and 4 are here provided.

Servo Motor	Continuous torque at zero speed	Current at continuous torque	Rated torque	Rated current	Rated speed	Mechanical rated power	Peak torque	Current at peak torque	Torque constant	B.e.m.f. between phases at rated speed	Moment of rotor inertia
	$M_0$ [Nm]	$I_0$ [A]	$M_N$ [Nm]	$I_N$ [A]	$n_N$ [rpm]	$P_N$ [kW]	$M_{max}$ [Nm]	$I_{max}$ [A]	$K_{t0}$ [Nm/A]	$V$ [V]	$J$ [kg cm <sup>2</sup> ]
	(5)	(1) (3) (5)	(5)	(1) (3) (5)		(5)		(1) (3)	(1) (2) (3)	(1) (2) (3)	
9C1.1.30	1,4	1,3	1,3	1,4	3000	0,41	4,1	4,5	1,147	208	0,6
9C1.2.30	2,3	1,8	2,0	1,7	3000	0,63	6,9	6,1	1,440	261	1,1
9C1.3.30	3,2	2,7	2,8	2,5	3000	0,88	9,6	9,0	1,350	245	1,5
9C1.4.30	4,2	3,3	3,5	2,9	3000	1,10	12,6	11,1	1,440	261	2,0

9C Servomotors are designed with a base speed of 3000 RPM.

However alternate speed values are available, different for each motor size. In particular a second speed value is available for each motor size.

For 9C1 the second speed is 6000 RPM.

For other speed values please contact ABB Technical Support.

Data and operating curves of the 9C1 servomotors, size 1, 2, 3 and 4 at 6000 RPM are here shown.

Servo Motor	Continuous torque at zero speed	Current at continuous torque	Rated torque	Rated current	Rated speed	Mechanical rated power	Peak torque	Current at peak torque	Torque constant	B.e.m.f. between phases at rated speed	Moment of rotor inertia
	$M_0$ [Nm]	$I_0$ [A]	$M_N$ [Nm]	$I_N$ [A]	$n_N$ [rpm]	$P_N$ [kW]	$M_{max}$ [Nm]	$I_{max}$ [A]	$K_{t0}$ [Nm/A]	$V$ [V]	$J$ [kg cm <sup>2</sup> ]
	(5)	(1) (3) (5)	(5)	(1) (3) (5)		(5)		(1) (3)	(1) (2) (3)	(1) (2) (3)	
9C1.1.60	1,4	2,1	1,2	2,0	6000	0,75	4,1	7,1	0,720	261	0,6
9C1.2.60	2,3	3,6	1,6	2,7	6000	1,01	6,9	12,1	0,720	261	1,1
9C1.3.60	3,2	5,2	2,3	3,9	6000	1,45	9,6	17,3	0,702	255	1,5
9C1.4.60	4,2	6,5	2,5	4,1	6000	1,57	12,6	21,6	0,738	268	2,0

(1) Voltage and current values RMS values

(2) Motor temperature 20 °C

(3) Tolerance  $\pm 10\%$

(4) Tolerance  $\pm 15\%$

(5) Duty type S1, ambient temperature 40 °C, mounted on steel flange (dim. 300x300x20 mm), altitude  $\leq 1000$  m.a.s.l.

### Operating Curves

Peak and continuous torque operating curves of the 9C1 servomotors.

*N 503001 - Size 9C1.1*

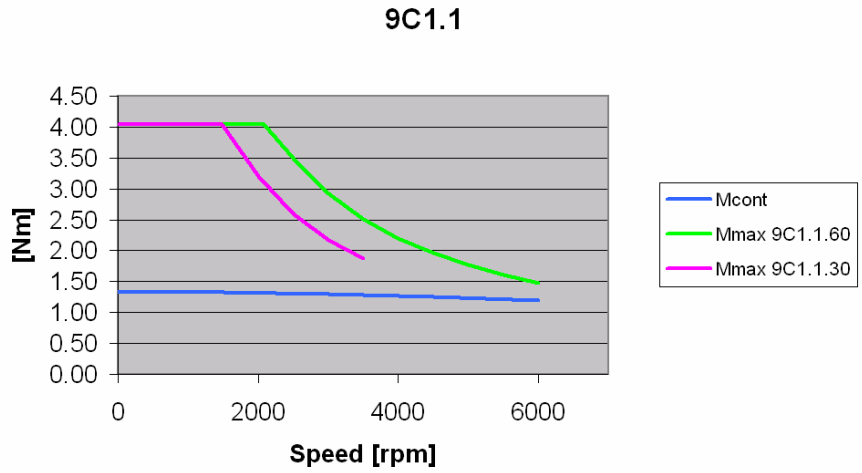

*N 503002 - Size 9C1.2*

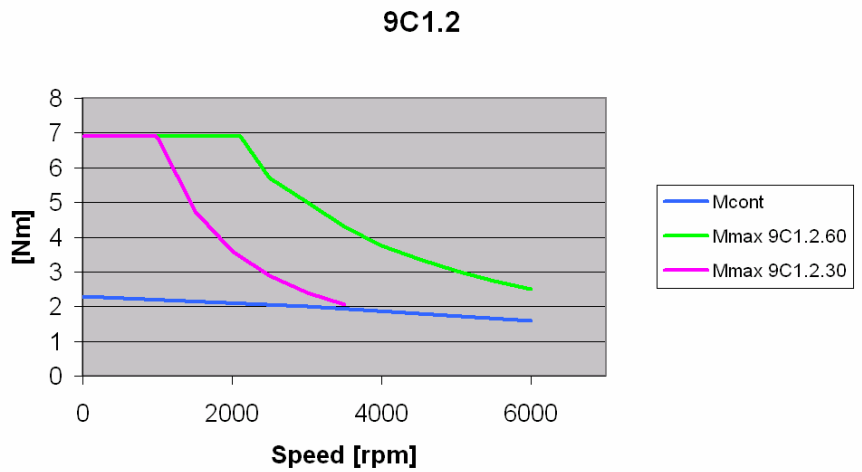

N 503003 - Size 9C1.3

9C1.3

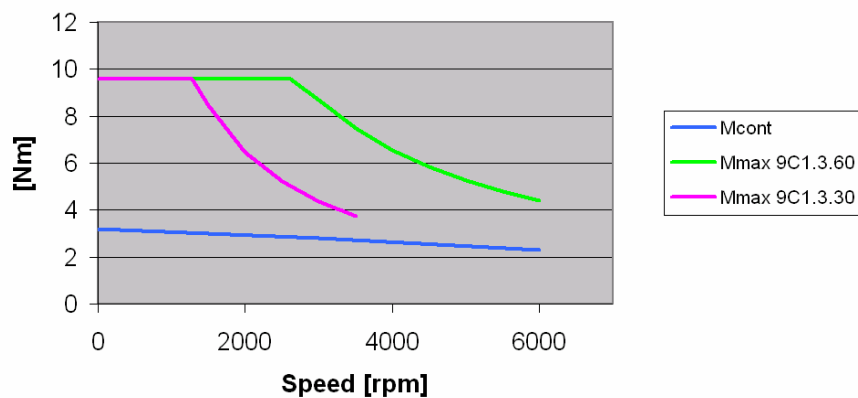

N 503004 - Size 9C1.4

9C1.4

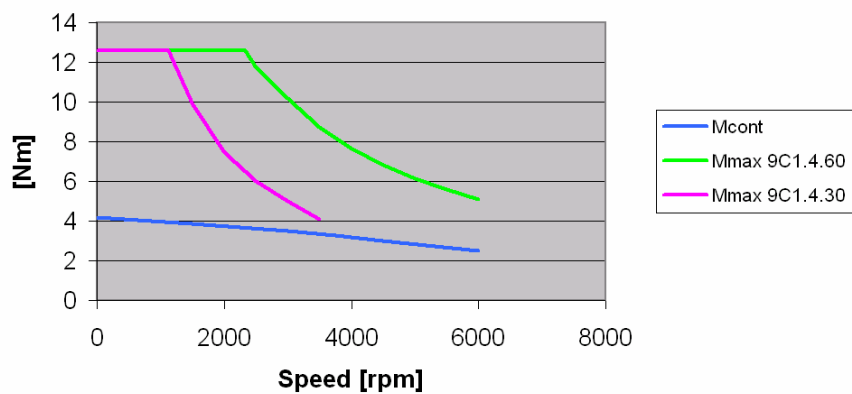

## Servomotor Size 9C4

Data and operating curves of the 9C4 servomotors, size 1, 2, 3 and 4 are here provided.

Servo Motor	Continuous torque at zero speed	Current at continuous torque	Rated torque	Rated current	Rated speed	Mechanical rated power	Peak torque	Current at peak torque	Torque constant	B.e.m.f. between phases at rated speed	Moment of rotor inertia
	$M_0$ [Nm]	$I_0$ [A]	$M_N$ [Nm]	$I_N$ [A]	$n_N$ [rpm]	$P_N$ [kW]	$M_{max}$ [Nm]	$I_{max}$ [A]	$K_{t0}$ [Nm/A]	$V$ [V]	$J$ [kg cm <sup>2</sup> ]
	(5)	(1) (3) (5)	(5)	(1) (3) (5)		(5)		(1) (3)	(1) (2) (3)	(1) (2) (3)	
9C4.1.30	4,3	3,0	3,9	2,8	3000	1,23	12,9	9,8	1,654	300	4,0
9C4.2.30	7,5	5,0	6,1	4,3	3000	1,92	22,5	16,7	1,704	309	7,7
9C4.3.30	9,4	6,0	6,9	4,6	3000	2,17	28,2	19,9	1,786	324	11,3
9C4.4.30	12,0	8,2	7,5	5,4	3000	2,36	36,0	27,3	1,665	302	15,0

9C Servomotors are designed with a base speed of 3000 RPM.

However alternate speed values are available, different for each motor size. In particular a second speed value is available for each motor size.

For 9C4 the second speed is 4000 RPM.

For other speed values please contact ABB Technical Support.

Data and operating curves of the 9C4 servomotors, size 1, 2, 3 and 4 at 4000 RPM are here shown.

Servo Motor	Continuous torque at zero speed	Current at continuous torque	Rated torque	Rated current	Rated speed	Mechanical rated power	Peak torque	Current at peak torque	Torque constant	B.e.m.f. between phases at rated speed	Moment of rotor inertia
	$M_0$ [Nm]	$I_0$ [A]	$M_N$ [Nm]	$I_N$ [A]	$n_N$ [rpm]	$P_N$ [kW]	$M_{max}$ [Nm]	$I_{max}$ [A]	$K_{t0}$ [Nm/A]	$V$ [V]	$J$ [kg cm <sup>2</sup> ]
	(5)	(1) (3) (5)	(5)	(1) (3) (5)		(5)		(1) (3)	(1) (2) (3)	(1) (2) (3)	
9C4.1.40	4,3	4,0	3,7	3,6	4000	1,55	12,9	13,2	1,232	298	4,0
9C4.2.40	7,5	6,9	5,4	5,2	4000	2,26	22,5	23,1	1,232	298	7,7
9C4.3.40	9,4	7,8	5,8	5,1	4000	2,43	28,2	26,1	1,365	330	11,3
9C4.4.40	12,0	10,0	6,3	5,5	4000	2,64	36,0	33,3	1,365	330	15,0

(1) Voltage and current values RMS values

(2) Motor temperature 20 °C

(3) Tolerance  $\pm 10\%$

(4) Tolerance  $\pm 15\%$

(5) Duty type S1, ambient temperature 40 °C, mounted on steel flange (dim. 300x300x20 mm), altitude  $\leq 1000$  m m.a.s.l.

## Operating Curves

Peak and continuous torque operating curves of the 9C4 servomotors.

*N 503005 - Size 9C4.1*

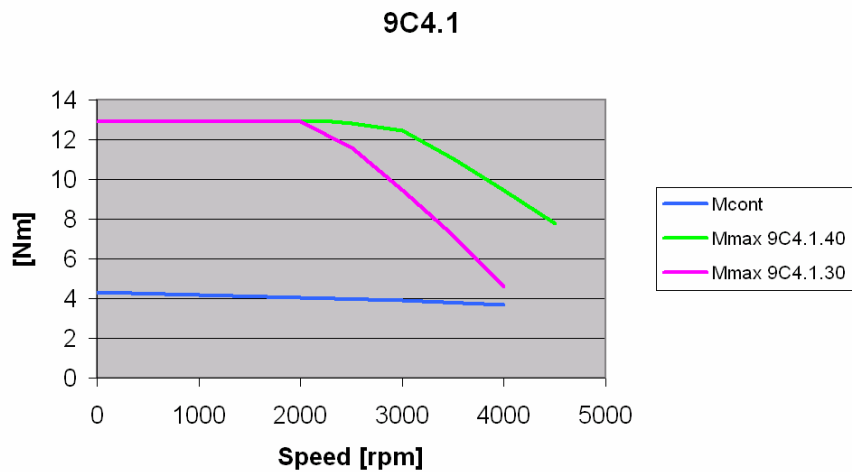

*N 503006 - Size 9C4.2*

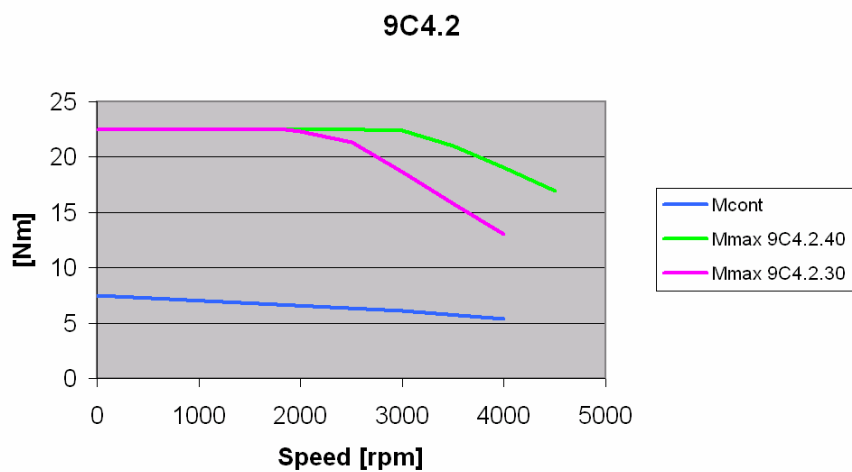

N 503007 - Size 9C4.3

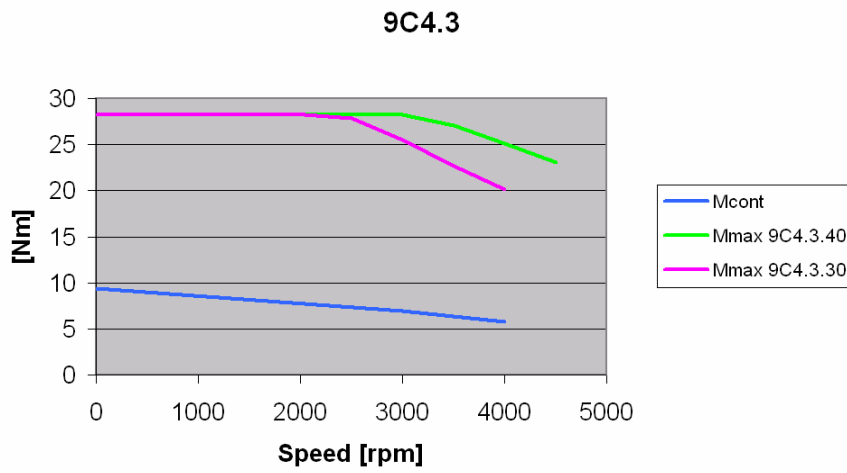

N 503008 - Size 9C4.4

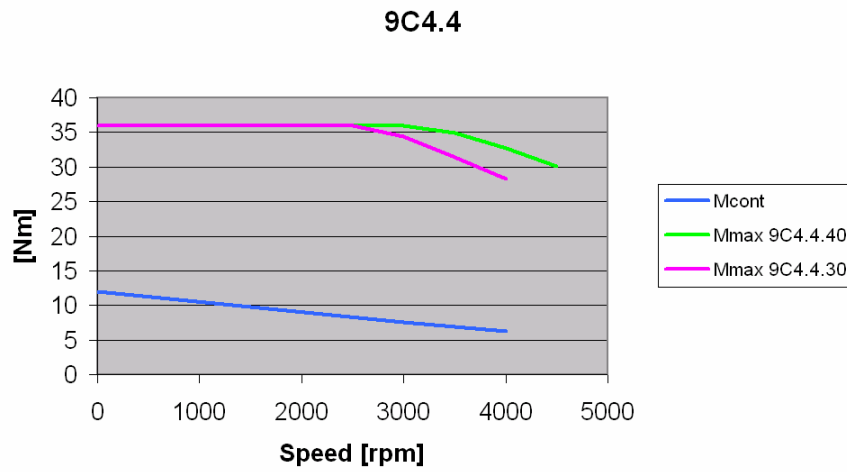

## Servomotor Size 9C5

Data and operating curves of the 9C5 servomotors, size 2, 3, 4, 5 and 6 are here provided.

Servo Motor	Continuous torque at zero speed	Current at continuous torque	Rated torque	Rated current	Rated speed	Mechanical rated power	Peak torque	Current at peak torque	Torque constant	B.e.m.f. between phases at rated speed	Moment of rotor inertia
	$M_0$ [Nm] (5)	$I_0$ [A] (1) (3) (5)	$M_N$ [Nm] (5)	$I_N$ [A] (1) (3) (5)	$n_N$ [rpm]	$P_N$ [kW] (5)	$M_{max}$ [Nm]	$I_{max}$ [A] (1) (3)	$K_{10}$ [Nm/A] (1) (2) (3)	$V$ [V] (1) (2) (3)	$J$ [kg cm <sup>2</sup> ]
9C5.2.30	12.3	9.2	9.0	7.1	3000	2.83	36.9	30.8	1.515	274.7	22.1
9C5.3.30	18.4	12.4	12.4	8.8	3000	3.90	55.2	41.3	1.688	306.1	32.1
9C5.4.30	23.5	15.4	14.0	9.7	3000	4.40	70.5	51.4	1.731	313.9	42.1
9C5.5.30	25.0	16.4	17.0	11.8	3000	5.34	75.0	54.7	1.731	313.9	52.0
9C5.6.30	30.0	19.7	18.0	12.4	3000	5.65	90.0	65.7	1.731	313.9	62.0

9C Servomotors are designed with a base speed of 3000 RPM.

However alternate speed values are available, different for each motor size. In particular a second speed value is available for each motor size.

For 9C5 the second speed is 2000 RPM.

For other speed values please contact ABB Technical Support.

Data and operating curves of the 9C5 servomotors, size 2, 3, 4, 5 and 6 at 2000 RPM are here shown.

Servo Motor	Continuous torque at zero speed	Current at continuous torque	Rated torque	Rated current	Rated speed	Mechanical rated power	Peak torque	Current at peak torque	Torque constant	B.e.m.f. between phases at rated speed	Moment of rotor inertia
	$M_0$ [Nm] (5)	$I_0$ [A] (1) (3) (5)	$M_N$ [Nm] (5)	$I_N$ [A] (1) (3) (5)	$n_N$ [rpm]	$P_N$ [kW] (5)	$M_{max}$ [Nm]	$I_{max}$ [A] (1) (3)	$K_{10}$ [Nm/A] (1) (2) (3)	$V$ [V] (1) (2) (3)	$J$ [kg cm <sup>2</sup> ]
9C5.2.20	12.3	6.1	10.3	5.3	2000	2.16	36.9	20.2	2.307	279.0	22.1
9C5.3.20	18.4	9.2	14.8	7.8	2000	3.10	55.2	30.7	2.272	274.7	32.1
9C5.4.20	23.5	11.9	17.1	9.1	2000	3.58	70.5	39.6	2.249	272.0	42.1
9C5.5.20	25.0	11.6	22.0	10.7	2000	4.61	75.0	38.6	2.452	296.5	52.0
9C5.6.20	30.0	13.1	22.0	10.1	2000	4.61	90.0	43.8	2.596	313.9	62.0

(1) Voltage and current values RMS values

(2) Motor temperature 20 °C

(3) Tolerance  $\pm 10\%$

(4) Tolerance  $\pm 15\%$

(5) Duty type S1, ambient temperature 40 °C, mounted on steel flange (dim. 300x300x20 mm), altitude  $\leq 1000$  m.a.s.l.

### Operating Curves

Peak and continuous torque operating curves of the 9C5 servomotors.

*N 503010 - Size 9C5.2*

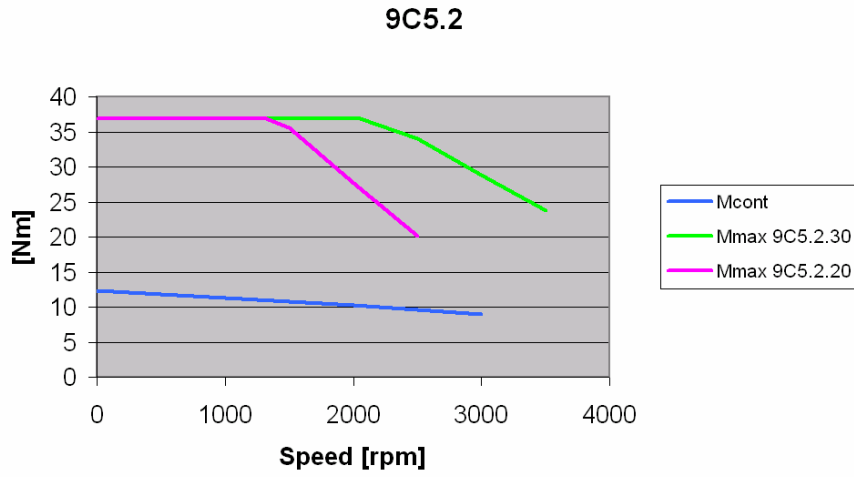

*N 503011 - Size 9C5.3*

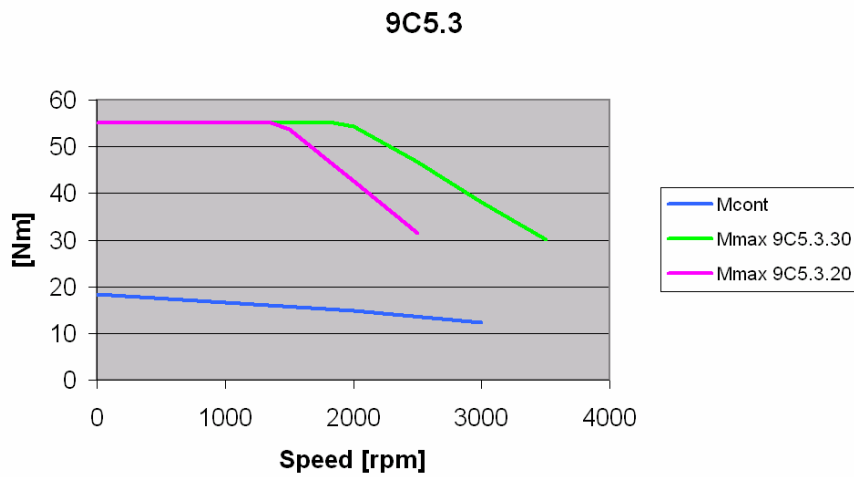

N 503012 - Size 9C5.4

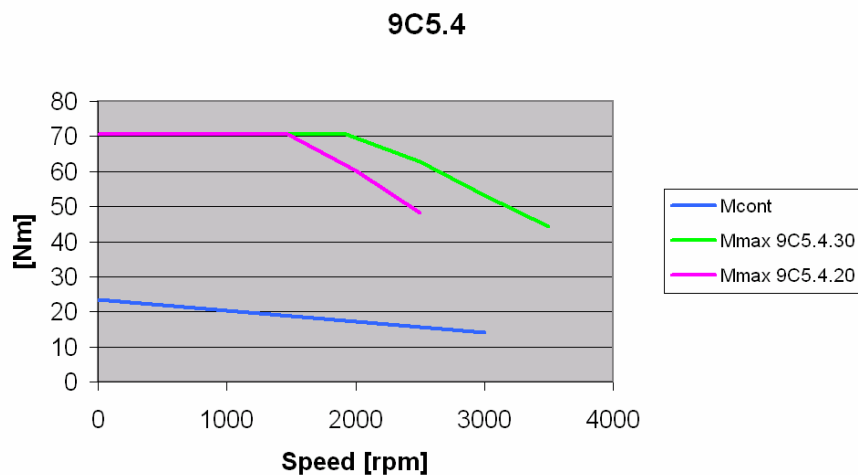

N 503013 - Size 9C5.5

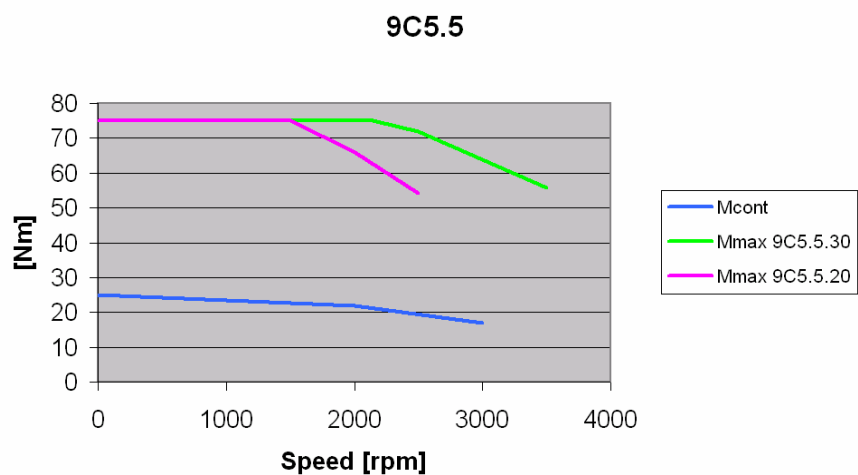

N 503014 - Size 9C5.6

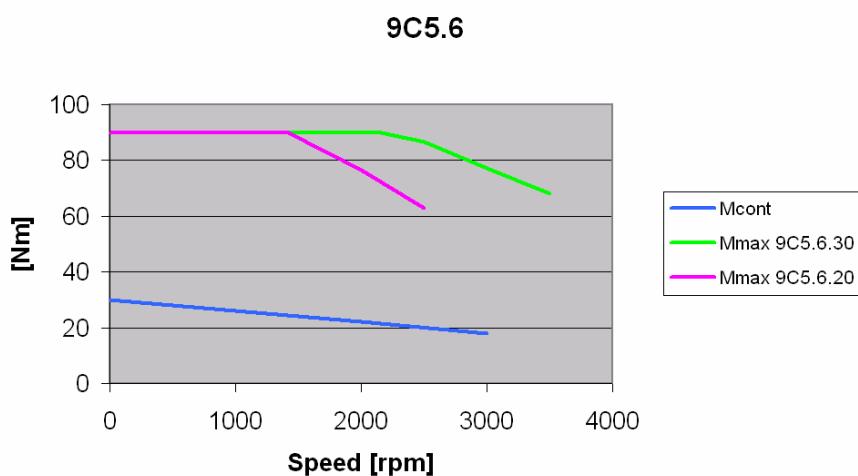

## Appendix A – Motor Code

The following table shows a quick key to the 9C Series Servomotors ordering code.

	Digit	1	2	3	4	5	6	7	8	9	10	11	12	13	14	15	16	17
<b>Example</b>		<b>9</b>	<b>C</b>	<b>1</b>	<b>1</b>	<b>3</b>	<b>0</b>	<b>0</b>	<b>R</b>	<b>0</b>	<b>0</b>	<b>0</b>	<b>0</b>	<b>0</b>	<b>1</b>	<b>M</b>	<b>0</b>	<b>0</b>
9C Series Brushless Servomotor		9	C															
Axis Height				1	4	5												
Size 1-2-3-4-5-6																		
Nominal Speed [rpm] / 100																		
Flange type, Shaft-end and mounting arrangements IM																		
Transducer type: Resolver																		
Terminal Box and Connections																		
Tolerance and Vibration Class "N"																		
Half Keyway mounted																		
Without Brake																		
With Brake																		
Thermal sensor PTC																		
Supply Voltage 400V																		
Accessories																		

For more details of ordering options please contact our Sales Office.

This page has been intentionally left blank

## Appendix B – Standards and Safety

---

### Introduction

9C series servomotors have been designed in compliance with IEC60034 norm. Moreover, for completeness, other norms have been followed. The main norms are here mentioned.

### Norm References

#### Standards

- [1] IEC 60034-1: “Rotating electrical Machines – Part 1: Rating and performance”.
- [2] IEC 60034-5: “Rotating electrical Machines – Part 5: Degrees of protection provided by the integral design of rotating electrical machines (IP code) – Classification”.
- [3] IEC 60034-6: “Rotating electrical Machines – Part 6: Methods of cooling (IC code)”.
- [4] IEC 60034-7: “Rotating electrical Machines – Part 7: Classification of types of construction, mounting arrangements and terminal box position (IM code)”.
- [5] IEC 60034-8: “Rotating electrical Machines – Part 8: Terminal markings and direction of rotation”.
- [6] IEC 60034-9: “Rotating electrical Machines – Part 9: Noise limits”.
- [7] IEC 60034-11: “Rotating electrical Machines – Part 11: Built-in thermal protection. Chapter 1: Rules for protection of electrical machines”.
- [8] IEC 60034-14-1: “Rotating electrical Machines – Part 14-1: Mechanical vibration of certain machines with shaft heights 56 mm and higher – Measurements, evaluation and limits of vibration”.
- [9] IEC 60034-18-1: “Rotating electrical Machines – Part 18: Functional evaluation of insulation systems for rotating electrical machines. Part 1: General guidelines”.
- [10] IEC 60034-25: “Rotating electrical Machines – Part 25: Guide for the design and performance of cage induction motors specifically designed for converter supply”.
- [11] IEC 60072-1: “Dimensions and output series for rotating electrical machines – Part 1: Frame numbers 56 to 400 and flange numbers 55 to 1080”.
- [12] IEC 60085 “Thermal evaluation and classification of electrical insulation” IEC 60204-1, “Safety of machinery – electrical equipment of machines. Part 1: General requirements”.

### Electromagnetic Compatibility (EMC) Directive

- [13] Directive 89/336/EEC, “On the approximation of the laws of the Member States relating to electromagnetic compatibility” and the subsequent amendments 92/31/EEC and 93/68/EEC.
- [14] Italian Legislative Decree, 4 December 1992, No. 476 “Attuazione della direttiva 89/336/CEE del Consiglio del 3 maggio 1989, in materia di ravvicinamento delle legislazioni degli Stati membri relative alla compatibilità elettromagnetica, modificata dalla direttiva 92/31/CEE del Consiglio del 28 aprile 1992” (Directive 89/336/EEC, “On the approximation of the laws of the Member States relating to electromagnetic compatibility” and the subsequent amendments 92/31/EEC and 93/68/EEC).
- [15] Italian Legislative Decree, 12 November 1996, No. 615 “ Attuazione della direttiva 89/336/CEE del Consiglio del 3 maggio 1989, in materia di ravvicinamento delle legislazioni degli Stati membri relative alla compatibilità elettromagnetica, modificata ed integrata dalla direttiva 92/31/CEE del Consiglio del 22 luglio 1993 e dalla direttiva 93/97/CEE del Consiglio del 29 ottobre 1993” (Implementation of the directive 89/336/EEC, 3 May 1989, “On the approximation of the laws of the Member States relating to electromagnetic compatibility” changed and integrated by the Directive of the Council 92/31/EEC, 22 July 1993 and by the Directive of the Council 93/97/EEC, 29 October 1993).

*IMPORTANT NOTE: This Legislative Decree repeals the Legislative Decree [14], excepting article 14, sub-section 2.*

### Low Voltage Directive

- [16] Directive 73/23/EEC, 19 February 1973, “Harmonization of the laws of Member States relating to electrical equipment designed for use within certain voltage limits”, integrated by the Directive 93/68/EEC, 29 June 1993.
- [17] Italian Law 18 October 1977, No. 791 “Attuazione della direttiva del Consiglio delle Comunità europee (n. 73/23/CEE) relativa alle garanzie di sicurezza che deve possedere il materiale elettrico destinato ad essere utilizzato entro taluni limiti di tensione” (Directive 73/23/EEC, 19 February 1973, “Harmonisation of the laws of Member States relating to electrical equipment designed for use within certain voltage limits”, integrated by the Directive 93/68/EEC, 29 June 1993).
- [18] Italian Legislative Decree, 25 November 1996, No. 626 “Attuazione della direttiva 93/68/CEE in materia di marcatura CE del materiale elettrico destinato ad essere utilizzato entro taluni limiti di tensione” (Implementation of the Directive 93/68/EEC concerning the CE marking of electric material designed for use within certain voltage limits).
- [19] “Directive 2006/95 of the European Parliament and of the Council, of 12 December 2006, on the harmonization of the laws of Member States relating to electrical equipment designed for use within certain voltage limits”.

**IMPORTANT NOTE:** This Directive [19] replaces and repeals the previous Low Voltage Directive 73/23/CEE [16], as of the 12<sup>th</sup> December 2007. Basically the Directive 2006/95 is not changed with respect to 73/23/CEE; the purpose of the new directive is to gather under a unique legislative text the directive 73/23/CEE and subsequent changes by 93/68.

## Compliance with EEC Directives and CE Marking

Conditions for compliance with EMC Directives of the ABB drive systems composed of **9C SERIES Servomotors**.

The compliance of the drive systems composed of 9C servomotors, defined in the title of this section, with the directives and/or legislative provisions, related to the Electromagnetic Compatibility, are only valid under the following conditions.

### Restricted Distribution

9C Servomotors are only delivered as component of the “**Restricted distribution**” Class, and only sold to professional assemblers to be included as part of a system or of an installation. The actual EMC behaviour is under the responsibility of the equipment manufacturer of the system or of the installation, to which the specific standards apply.

Therefore the CE marking, placed on the 9C SERIES servomotor, only certifies the compliance of the said components with the directives and the laws specified in section *Low Voltage Directive*.

### Mounting and Installing Instructions

**9C Servomotors presented in this Manual must be installed according to the instructions prescribed in this Manual**; provisions indicated in this Chapter at section *Application Guidelines for Electromagnetic Compatibility* must also be strictly followed.

### Compliance of the Drive Systems with the Directives

#### Declaration of Conformity

ABB declares that, under the conditions specified in this document, in particular in section *Compliance with EEC Directives and CE Marking*, the drive systems composed of the **SERIES 9C Servomotors** comply with EMC European Directives [13], including the most recent changes, with the related endorsement Italian legislation [14] and [15], and with the Low Voltage European Directives [16], [17] and [18]; the applicable regulatory references are indicated in section *Norm References*.

### Note for the Application of Other EEC Directives



Servomotors are not subject to other EEC directives, apart from those specified in section *Norm References*. As far as the 89/392 EEC Machine Directive and subsequent changes 91/368/EEC, 93/44 EEC, 93/68 EEC, Italian legislation for implementation of the Presidential Decree No. 459, 24 July 1996, the Certificate of Incorporation (also known as “Manufacturer’s declaration”) is sometimes required.

#### Certificate of Incorporation

ABB, according to what required in the Machine Directive (MD) 89/392 EEC and subsequent changes, declares that **SERIES 9C Servomotors**, must be installed in accordance with our installation instructions and must not be put into service until the machinery into which it is to be incorporated has been declared in conformity with the Machinery Directive.

## Safety Instructions

### Meaning of the Symbols

	<b>WARNING! Dangerous Voltage</b>
	<b>WARNING! General Warning</b>

### Installation and Operation

This Manual is intended for qualified personnel who have a relevant experience with installation of servodrives, troubleshooting, maintenance of servomotors and drive systems in general.



**WARNING!** Only properly qualified personnel who are familiar with operation on servomotors are allowed to perform the commissioning and operation activities on the drive.



**WARNING!** The cabinet, the power supply and the auxiliary supply must be disconnected during mechanical and electrical installation of the servomotor.



**WARNING!** For no reason should an unskilled operator work on the servomotor terminal box.

### Dangerous Temperature



**WARNING!** During operation the servomotor can reach high temperatures up to 140 °C (with ambient temperature of 40 °C) **with consequent risk of scalding.**

## Application Guidelines for Electromagnetic Compatibility

This section applies to prescriptions specified in *Note for the Application of Other EEC Directives* concerning the standard about electromagnetic compatibility for drive systems [13-15].

The need to follow precise rules as far as EMC is concerned, is due to the increasing use of electronic power units, which, for the used techniques, represent a noise source in a wide frequency range (**emission**). These devices are at the same time sensitive to noise produced by other devices; for this reason they must be provided with an adequate **immunity** level.

Noise is conventionally classified as **low frequency** ( $0 < f < 9$  kHz) and **high frequency** ( $f > 9$  kHz) noise.

In the range of the low frequency noise, the **harmonic frequency** phenomena of the power supply line frequency are particularly important.

There are also **large spectrum** events, such as electrostatic discharges in the air or by contact.

Noise can be transmitted both through conductors (<**conducted noise**>; conducted emission: 0,15 MHz ÷ 30 MHz) and through irradiation (<**irradiated noise**>; irradiated emission: 30 MHz ÷ 1000 MHz). **Industrial experience showed that the main causes of compatibility lack are caused by conducted noise.**

The servomotor installation must be carried out by closely following the instructions of this Manual and, in particular, of chapters *Mechanical Installation* and *Electrical Installation*.

For electromagnetic compatibility, the installation must be carried out following some appropriate instructions.

**The motor assembly**, including the **9C SERIES** servomotor and the angle position transducer, as well as the motor thermal switch and - where necessary - the brake, is usually mounted on the machine at a certain distance from the electrical control cabinet.

There are actually two different types of installations: the one referring to the electrical control cabinet manufacture and the actual on-site installation, which is carried out by the installer at the premises of the final user. This guide deals with instructions related to the connections of the motor only.

### Electric System

As stated above, we refer to the on-site installation, in the final installation of the machine. For some types of machines (such as small machine tools), the electrical control cabinet is physically connected to the machine and therefore the on-site electrical equipment is reduced to the connection of the machine to the power mains.

Nevertheless, the electrical control cabinet is usually placed at a certain distance from the machine, on which the motor assembly is mounted; sometimes there is also a remote control desk, to which conductors could be connected.

In this case, since the emission problem is strictly linked to installation factors, the following recommendations come from good technique standards and from experience in field and must be basically considered as guidelines and not as sure solutions.

- **Keep in mind that the servomotor is intended for the use in a “Second Environment”, i.e. industrial environments where the low voltage network does not feed residential buildings.**
- **Carefully study the installation cable routes, minimizing their length.**
- **All the metal channels and sheaths and, in general, all the shields, if not otherwise specified, must be earthed both on the electrical control cabinet side and on the motor side; the earthing connections must have a largely dimensioned section and their route must be as short as possible.**
- **A good EMC compliant installation requires very efficient earths.**

### **Customer Service**

For any additional question and support, please contact our Customer Service.

ABB S.p.A – Line S  
Customer Service  
Viale dell’Industria, 18  
I - 20010 Vittuone (MI)  
ITALY  
Telephone +39 02 9034.1  
Telefax +39 02 9034.7839







9C SERVOMOTORS MANUAL  
MANUM09 REV E EN  
EFFECTIVE: 15.03.2008

---

**ABB S.p.a.**

**Line S (Servomotors & Servodrives)**

Headquarters and Offices

Viale dell'Industria, 18

I - 20010 Vittuone (MI)

ITALY

Telephone: +39 02 9034 1

Fax: +39 02 9034 7761

E-mail: [sace.ssg@it.abb.com](mailto:sace.ssg@it.abb.com)

Internet: [www.abb.com](http://www.abb.com) Servomotors

---

**ABB S.p.a.**

**Line S (Servomotors & Servodrives)**

Export

Via Luciano Lama, 33

I - 20090 Sesto San Giovanni (MI)

ITALY

Telephone: +39 02 2414 1

Fax: +39 02 2414 3972

E-mail: [sace.ssg@it.abb.com](mailto:sace.ssg@it.abb.com)