

# DIFFERENTIAL PROTECTION METHODOLOGY FOR ARBITRARY THREE-PHASE POWER TRANSFORMERS

Z. Gajić

ABB AB-SA Products, Sweden; [zoran.gajic@se.abb.com](mailto:zoran.gajic@se.abb.com)

**Keywords:** power transformer, phase shifting transformer, converter transformer, differential protection.

## Abstract

This paper describes how to provide universal, current based, differential protection for any three-phase power transformer, including phase-shifting transformers with variable phase angle shift and special converter transformers with non-standard but fixed phase angle shift (e.g. 22.5°). The use of standard transformer differential protection for such applications is considered impossible in the protective relaying standards and practices currently applied. This universal differential protection method only requires stand-alone CTs on all sides of the protected transformer. Thus, any buried current transformers within the tank of the protected power transformer are not required regardless transformer construction details and internal on-load tap-changer configurations.

## 1 Introduction

The common characteristic for all types of three-phase power transformers is that they introduce the phase angle displacement  $\Theta$  between no-load voltages from the two sides of the transformer. The only difference between standard power transformers, special converter transformers and a phase shifting power transformers (PST) is that:

- ◆ Standard three-phase power transformers introduce a fixed phase angle shift  $\Theta$  of  $n \cdot 30^\circ$  ( $n=0, 1, 2, \dots, 11$ ) between its terminal no-load voltages;
- ◆ Special converter transformers introduce a fixed phase angle shift  $\Theta$  different from  $30^\circ$  or a multiple of  $30^\circ$  between its terminal no-load voltages (e.g. 22.5°); and
- ◆ Phase-shifting transformers introduce a variable phase angle shift  $\Theta$  between its terminal no-load voltages (e.g. 0°-18° in 15 steps of 1.2°).

Actually, it can be shown that strict rules do exist only for the phase angle shift between positive, negative and zero sequence, no-load voltage components between the two sides of any three-phase power transformer [3,8]. However, as soon as the power transformer is loaded, these sequence voltage relationships will not longer be valid, due to the voltage drop across the power transformer impedance. However it can be shown that the exactly the same phase angle relationships will

be valid for sequence current components, which flow into the power transformer on winding one side and flow out from the power transformer on winding two side [3,8]. By using these properties of the sequence current components it is possible to make a differential protection for arbitrary power transformer including the special converter transformers and phase shifting transformer by just measuring currents on all side of the protected object. By doing so, simple but effective differential protection for special converter transformers and PSTs can be achieved that is very similar to already well-established numerical differential protection for standard power transformers [1,2]. By using this method the differential protection for arbitrary power transformer will be ideally balanced for all symmetrical and non-symmetrical through-load conditions and external faults. Such universal differential protection method will make much easier application of differential protection on PSTs and special converter transformers.

## 2 Differential protection methodology

In order to provide numerical transformer differential protection for arbitrary three-phase power transformer, it is necessary in the relay software to properly compensate for:

- ◆ primary current magnitude difference on different sides of the protected transformer (i.e. current magnitude compensation);
- ◆ power transformer phase angle shift (i.e. phase angle shift compensation); and to provide optional
- ◆ zero sequence current elimination (i.e. zero sequence current compensation).

It can be shown that all these three compensations can be provided by proper treatment of the measured three-phase currents  $I_{L1}$ ,  $I_{L2}$  and  $I_{L3}$ , on every transformer side. Each three-phase current set shall be first altered in accordance with the following matrix equation:

$$\begin{bmatrix} I'_{L1} \\ I'_{L2} \\ I'_{L3} \end{bmatrix} = k \cdot MX \cdot \begin{bmatrix} I_{L1} \\ I_{L2} \\ I_{L3} \end{bmatrix} \quad (2.1)$$

Where  $I'_{L1}$ ,  $I'_{L2}$  &  $I'_{L3}$  is the treated three-phase currents converted to the per unit values,  $k$  is a factor which performs the current magnitude compensation and  $MX$  is a three-by-three matrix which performs phase angle shift compensation and optional zero sequence current elimination.

Once such handling of the measured three-phase currents is performed on every side of the protected N-winding power transformer, the differential currents in per unit can be calculated in accordance with the following matrix equation:

$$\begin{bmatrix} I_{d\_L1} \\ I_{d\_L2} \\ I_{d\_L3} \end{bmatrix} = \sum_{i=1}^N \begin{bmatrix} I'_{L1\_Wi} \\ I'_{L2\_Wi} \\ I'_{L3\_Wi} \end{bmatrix} \quad (2.2)$$

Thus, in order to provide the differential protection for arbitrary N-winding, three-phase, power transformer appropriate numerical values for k factor and MX matrix elements shall be assigned to every winding/side of the protected transformer.

### 2.1 Magnitude compensation

By selecting the appropriate value for the factor k on every side of the protected power transformer, the current magnitude compensation for differential protection is performed. Note that for windings of one power transformer only common electrical quantity is a power which flows through the transformer. Therefore, the maximum rated apparent power among all power transformer windings is typically selected as a base (e.g. 100%) for the transformer differential protection. Thus, in order to achieve current magnitude compensation, the individual phase currents must be normalized on all power transformer sides by dividing them by the so-called base current. The base current in primary amperes can be calculated for a power transformer winding by using the following equation:

$$I_{Base} = \frac{S_{rMax}}{\sqrt{3} \cdot U_r} \quad (2.3)$$

where:

- ◆  $I_{Base}$  is winding base current in primary amperes.
- ◆  $S_{rMax}$  is the maximum rated apparent power among all power transformer windings. The maximum value, as stated on the protected power transformer rating plate, is typically used.
- ◆  $U_r$  is winding rated phase-to-phase, no-load voltage; its value for all windings are typically stated on the transformer rating plate.

Note that when a power transformer incorporates an OLTC, rated no load voltage has different values for different OLTC positions on at least one side of the power transformer. Therefore, the base current will have different values on that side of the protected power transformer for different OLTC positions as well. Thus, for the winding where the OLTC is located, different  $I_{Base}$  values shall be used for every OLTC position, in order to correctly compensate for the winding current magnitude variations caused by OLTC operation. For the winding with power rating equal to  $S_{rMax}$  the base current is equal to the winding rated current which is usually stated on the power transformer rating plate.

Note that the base current in equation (2.3) is given in primary amperes. Differential relays may use currents in

secondary amperes to perform their algorithm. In such case the base current in primary amperes obtained from equation (2.3), shall be converted to the CT secondary side by dividing it by the ratio of the main current transformer located on that power transformer side. See Table 1 for an example. Once the base currents are calculated for every power transformer winding, the k factor for every individual winding is calculated as the reciprocal value of the winding base current in accordance with the following equation:

$$k = \frac{1}{I_{Base}} \quad (2.4)$$

### 2.2 Phase angle and zero sequence current compensation

By selecting the appropriate numerical values for the elements of the three-by-three matrix MX, on every side of the protected power transformer, phase angle shift compensation and optional zero sequence current elimination is provided.

In order to only provide the phase angle shift compensation a matrix transformation  $M(\Theta)$  shall be used to calculate numerical values for the MX matrix elements.

$$M(\Theta) = \frac{1}{3} \cdot \begin{bmatrix} 1+2 \cdot \cos(\Theta) & 1+2 \cdot \cos(\Theta+120^\circ) & 1+2 \cdot \cos(\Theta-120^\circ) \\ 1+2 \cdot \cos(\Theta-120^\circ) & 1+2 \cdot \cos(\Theta) & 1+2 \cdot \cos(\Theta+120^\circ) \\ 1+2 \cdot \cos(\Theta+120^\circ) & 1+2 \cdot \cos(\Theta-120^\circ) & 1+2 \cdot \cos(\Theta) \end{bmatrix} \quad (2.5)$$

In order to simultaneously provide the phase angle shift compensation and zero sequence current elimination a matrix transformation  $M0(\Theta)$  shall be used to calculate numerical values for the MX matrix elements.

$$M0(\Theta) = \frac{2}{3} \cdot \begin{bmatrix} \cos(\Theta) & \cos(\Theta+120^\circ) & \cos(\Theta-120^\circ) \\ \cos(\Theta-120^\circ) & \cos(\Theta) & \cos(\Theta+120^\circ) \\ \cos(\Theta+120^\circ) & \cos(\Theta-120^\circ) & \cos(\Theta) \end{bmatrix} \quad (2.6)$$

Note that  $\Theta$  is an angle for which the winding no-load, positive sequence voltage component shall be rotated in order to overlay with the no-load, positive sequence voltage component from the winding which is selected as a reference for the phase angle shift compensation. Thus, the reference winding can be understood as a winding to which all other winding currents are aligned with, but its own currents are not rotated (i.e. rotated by zero degrees). The angle  $\Theta$  has a positive value when rotation is in the anticlockwise direction and a negative value when rotation is in the clockwise direction. Note that it is equally possible to select any winding of the protected power transformer as the reference winding for the phase angle shift compensation. Accordingly, it is possible to arrange phase angle shift compensation for one transformer in more than one way within the differential protection.

Note that for differential protection applied for a PST, angle  $\Theta$  has different values for different OLTC positions on at least one side. Therefore, the MX matrix elements will have different numerical values for different OLTC positions.

### 3 Differential protection application examples

Examples of how to arrange differential currents calculation, in accordance with the new method for some practical transformer applications will be presented in this section.

#### 3.1 Standard two-winding, YNd1 transformer

The transformer rating data, relevant application information for the differential protection and the vector diagram for the transformer no-load voltages are given in Figure 1. The maximum winding power (i.e. base power) for this application is 20.9MVA, and against this value, the base primary currents and base currents on the CT secondary side are calculated as shown in Table 1.

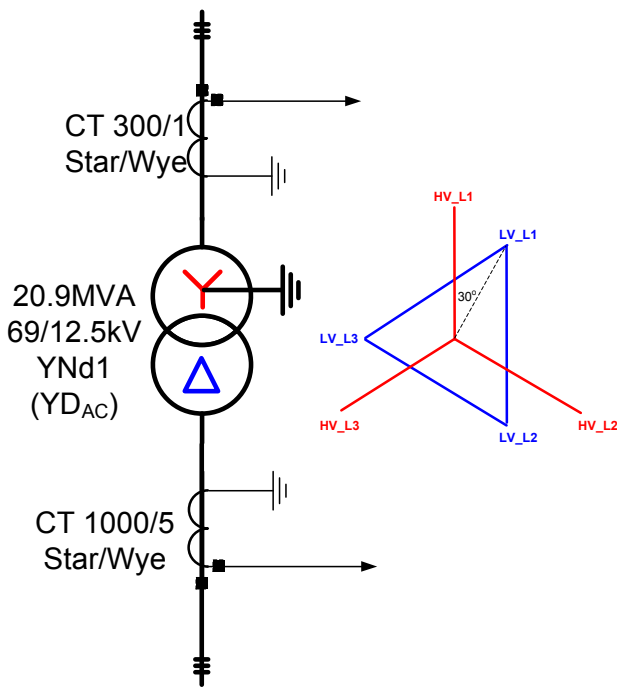

Figure 1: Application data for the YNd1 power transformer.

Table 1: Base current calculations for the YNd1 transformer

	Primary Base Current	Base current on CT secondary side
W1, 69kV-Star	$\frac{20.9\text{MVA}}{\sqrt{3} \times 69\text{kV}} = 174.9\text{A}$	$\frac{174.9}{300/1} = 0.583\text{A}$
W2, 12.5kV-Delta	$\frac{20.9\text{MVA}}{\sqrt{3} \times 12.5\text{kV}} = 965.3\text{A}$	$\frac{965.3}{1000/5} = 4.827\text{A}$

Regarding phase angle compensation two solutions are possible (in general for an N-winding transformer at least N different possible solutions exist). The first solution is to take W1 (i.e. 69kV) side as the reference side (with 0° phase angle shift). The vector group of the protected transformer is Yd1 [5] (ANSI designation YD<sub>AC</sub>), thus the W2 (i.e. 12.5kV) delta

winding, positive sequence, no-load voltage component shall be rotated by 30° in the anticlockwise direction in order to overlay it with the W1 positive sequence, no-load voltage component. For this first solution the required matrices for both windings are shown in Table 2. Zero sequence current shall be removed from the 69kV side, because its neutral point is solidly grounded.

Table 2: First solution for phase angle shift compensation for the YNd1 transformer

	Compensation matrix MX
W1, 69kV-Star, selected as reference winding	$M0(0^\circ) = \frac{1}{3} \cdot \begin{bmatrix} 2 & -1 & -1 \\ -1 & 2 & -1 \\ -1 & -1 & 2 \end{bmatrix}$
W2, 12.5kV-Delta	$M(30^\circ) = \begin{bmatrix} 0.9107 & -0.2440 & 0.3333 \\ 0.3333 & 0.9107 & -0.2440 \\ -0.2440 & 0.3333 & 0.9107 \end{bmatrix}$

The second possible solution is to take W2 side as the reference side (with 0° phase angle shift). The vector group of the protected transformer is Yd1, thus the W1 (star winding) positive sequence, no-load voltage component shall be rotated by 30° in a clockwise direction (see Figure 1) in order to overlay it with the W2 positive sequence, no-load voltage component. For this second phase angle compensation solution the required matrices are shown in Table 3.

Table 3: Second solution for phase angle shift compensation for the YNd1 transformer

	Compensation matrix MX
W1, 69kV-Star	$M0(-30^\circ) = \frac{1}{\sqrt{3}} \cdot \begin{bmatrix} 1 & 0 & -1 \\ -1 & 1 & 0 \\ 0 & -1 & 1 \end{bmatrix}$
W2, 12.5kV-Delta, selected as reference winding	$M(0^\circ) = \begin{bmatrix} 1 & 0 & 0 \\ 0 & 1 & 0 \\ 0 & 0 & 1 \end{bmatrix}$

Note that the second solution is identical with the traditionally used transformer differential protection schemes that utilize analogue differential relays and interposing CTs. In such schemes, the y/d connected interposing CTs are used on star-connected power transformer windings, while y/y connected interposing CTs are used on delta-connected power transformer windings.

However, note that the first solution correlates better with the physical winding layout around the magnetic core limb within the protected power transformer. In the case of an internal fault in phase L1 of the HV star connected winding for the

second solution, equally large differential currents would appear in phases L1 and L3 and the differential relay would operate in both phases. However, for the first solution, the biggest differential current would appear in phase L1 clearly indicating the actual faulty phase. It can also be shown that a slightly larger magnitude of the differential current would be calculated for such an internal fault by using the first solution (i.e. for such phase-to-ground fault, the ratio of the differential currents will be  $1^{st} : 2^{nd} = \frac{2}{3} : \frac{1}{\sqrt{3}}$ ). Thus, the

first solution is recommended for the numerical differential protection and it can be simply formulated using the following guidelines:

- ◆ the first star (i.e. wye) connected power transformer winding shall preferably be selected as the reference winding for the transformer differential protection;
- ◆ the first delta connected power transformer winding shall be selected as the reference winding only for power transformers without any star connected windings;
- ◆ the first delta connected winding within the protected power transformer can be selected as the reference winding only if a solution similar with traditionally applied transformer differential protection schemes utilizing analogue differential relays and interposing CTs is required;
- ◆ for special converter transformers (see Section 3.2), a zigzag connected power transformer winding might be selected as reference winding; and
- ◆ for PST applications typically the S-side shall be selected as the reference side (see Section 3.3).

Once the base currents and MX matrix elements are determined, matrix equation to calculate differential currents can be written. Equation using the first solution for phase angle shift compensation and base currents in secondary amperes will only be presented here:

$$\begin{bmatrix} I_{d\_L1} \\ I_{d\_L2} \\ I_{d\_L3} \end{bmatrix} = \frac{1}{0.583} \cdot M(0(-30^\circ)) \cdot \begin{bmatrix} I_{L1\_69} \\ I_{L2\_69} \\ I_{L3\_69} \end{bmatrix} + \frac{1}{4.827} \cdot M(0^\circ) \cdot \begin{bmatrix} I_{L1\_12.5} \\ I_{L2\_12.5} \\ I_{L3\_12.5} \end{bmatrix} \quad (3.1)$$

### 3.2 Special converter transformer

In this example the application of the transformer differential protection method will be illustrated for a 24-pulse converter transformer [6]. This converter transformer is quite special

because within the same transformer tank, two three-phase transformers, of similar design are put together. The first internal transformer has vector group  $Zy11\frac{3}{4}d10\frac{3}{4}$ . The second internal transformer has vector group  $Zy0\frac{1}{4}d11\frac{1}{4}$ . Such an arrangement gives an equivalent five-winding power transformer with a  $15^\circ$  phase angle shift between LV windings of the same connection type. The rating data for this equivalent five-winding transformer are 22/0.7/0.7/0.7/0.7kV; 2600/650/650/650/650kVA. The power transformer design details and corresponding phasor diagrams for positive sequence, no-load voltages are shown in Figure 2.

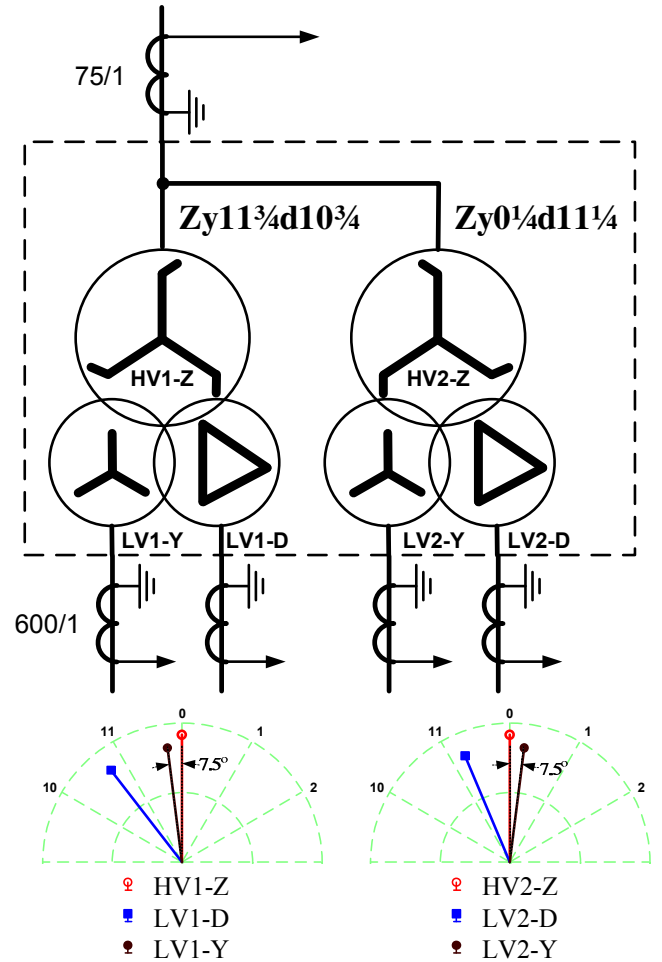

Figure 2: 24-pulse converter transformer design.

The maximum winding power for this equivalent five-winding transformer is 2.6MVA, and against this value, the base primary currents and base currents on the CT secondary side are calculated as shown in Table 4.

Table 4: Base currents for the converter transformer

Winding	Base current in	
	Primary Amperes	Secondary Amperes
HV-Z, 22kV	68.2A	0.909A
LV1-Y, 705V	2129A	3.548A
LV1-D, 705V	2129A	3.548A
LV2-Y, 705V	2129A	3.548A
LV2-D, 705V	2129A	3.548A

The best solution for the phase angle shift compensation is to take the 22kV, HV side for the reference winding. Zero sequence current elimination is not required on any side of the protected transformer. The corresponding MX values are given in Table 5. Once base currents and MX matrix elements are determined for every side, the overall matrix equation to calculate differential currents can be written.

Table 5: MX matrices for the converter transformer

Winding	Compensation matrix
HV-Z, 22kV	M(0°)
LV1-Y, 705V	M(-7.5°)
LV1-D, 705V	M(-37.5°)
LV2-Y, 705V	M(+7.5°)
LV2-D, 705V	M(-22.5°)

### 3.3 Phase shifting transformer

In this example the application of this differential protection method will be illustrated for an actual 1630MVA; 400kV; +18°; 50Hz PST of asymmetric, two-core design [7]. This type of PST is also known as the Quad Booster [4, 7]. For an asymmetric PST design, both the base current and the angle  $\Theta$  are dependent on actual OLTC position. All necessary information for application of the differential protection method can be obtained directly from the PST nameplate. A relevant part of PST rating plate is shown in Figure 3.

The first column in Figure 3 represents available OLTC positions, in this application 33. From column three it is obvious that the base current for PST Source side is constant for all OLTC positions and has a value of 2353A. Column five in Figure 3 gives the base current variation for PST Load side. Finally the last (i.e. fourteenth) column in Figure 3 shows how the no-load phase angle shift varies across the PST for different OLTC positions. Note that the phase angle shift on the PST rating plate is given as a positive value when the load side positive sequence, no-load voltage leads the source side positive sequence, no-load voltage [7] (i.e. advanced mode of operation). Therefore if the phase shift from Figure 3 is associated with the load side (i.e. source side taken as reference side for phase angle compensation) the angle values from the rating plate must be taken with the minus sign (see the PST vector diagram in Figure 3).

This particular PST has a five-limb core construction for both internal transformers (i.e. serial and excitation transformer). Therefore the zero sequence current will be properly transferred across PST and zero sequence current elimination is not required on any side. Consequently M( $\Theta$ ) transformation shall be used on both sides.

Thus, for every OLTC position, the appropriate matrix equation for differential currents calculation can be written. The equation for this PST when OLTC is in position 30 is only presented here:

Terminal	Source		Load		Series winding		Booster winding		Exciter winding		Regulation winding		Phase angle at no load advanced
	S8, S12, S4	L8, L12, L4	S8, S12, S4	L8, L12, L4	S8, S12, S4	L8, L12, L4	A25, A26, B25, B26	C25, C26	S8, S12, S4	ED	A4, B4, C4	FD	
Pos.	Voltage V	Current A	Voltage V	Current A	Voltage V	Current A	Voltage V	Current A	Voltage V	Current A	Voltage V	Current A	
33	400000	2353	420509	2238	74895	2238	121245	1382	400000	725.8	121245	2394	18.0°
32	400000	2353	419276	2245	72555	2245	117456	1386	400000	705.2	117456	2401	17.4°
31	400000	2353	418079	2251	70214	2251	113687	1390	400000	684.4	113687	2408	16.9°
30	400000	2353	416918	2257	67874	2257	109878	1394	400000	663.4	109878	2415	16.4°
29	400000	2353	415793	2263	65533	2263	106089	1398	400000	642.3	106089	2422	15.8°
28	400000	2353	414705	2269	63193	2269	102300	1402	400000	620.9	102300	2428	15.3°
27	400000	2353	413653	2275	60852	2275	98512	1405	400000	599.5	98512	2434	14.8°
26	400000	2353	412639	2281	58512	2281	94723	1409	400000	577.8	94723	2440	14.2°
25	400000	2353	411662	2286	56171	2286	90934	1412	400000	556.0	90934	2446	13.7°
24	400000	2353	410713	2291	53831	2291	87145	1415	400000	534.1	87145	2451	13.1°
23	400000	2353	409822	2296	51490	2296	83356	1418	400000	512.0	83356	2457	12.6°
22	400000	2353	408959	2301	49150	2301	79567	1421	400000	489.7	79567	2462	12.0°
21	400000	2353	408134	2306	46809	2306	75778	1424	400000	467.4	75778	2467	11.5°
20	400000	2353	407348	2310	44469	2310	71989	1427	400000	444.9	71989	2472	10.9°
19	400000	2353	406601	2315	42128	2315	68200	1430	400000	422.2	68200	2476	10.3°
18	400000	2353	405893	2319	39788	2319	64411	1432	400000	399.5	64411	2481	9.8°
17C	400000	2353	405225	2322	37448	2322	60623	1435	400000	376.6	60623	2485	9.2°
17B	400000	2353	405225	2322	37448	2322	60623	1435	400000	376.6	60623	2485	9.2°
17A	400000	2353	405225	2322	37448	2322	60623	1435	400000	376.6	60623	2485	9.2°
16	400000	2353	404595	2326	35107	2326	56834	1437	400000	353.6	56834	2489	8.6°
15	400000	2353	404006	2329	32767	2329	53045	1439	400000	330.5	53045	2492	8.1°
14	400000	2353	403457	2333	30426	2333	49256	1441	400000	307.3	49256	2496	7.5°
13	400000	2353	402947	2335	28086	2335	45467	1443	400000	284.0	45467	2499	6.9°
12	400000	2353	402478	2338	25745	2338	41678	1444	400000	260.7	41678	2502	6.4°
11	400000	2353	402049	2341	23405	2341	37889	1445	400000	237.2	37889	2504	5.8°
10	400000	2353	401660	2343	21064	2343	34100	1447	400000	213.7	34100	2507	5.2°
9	400000	2353	401313	2345	18724	2345	30311	1449	400000	190.1	30311	2509	4.6°
8	400000	2353	401005	2347	16383	2347	26522	1450	400000	166.5	26522	2511	4.1°
7	400000	2353	400739	2348	14043	2348	22733	1451	400000	142.8	22733	2513	3.5°
6	400000	2353	400513	2350	11702	2350	18945	1451	400000	119.1	18945	2514	2.9°
5	400000	2353	400329	2351	9362	2351	15156	1452	400000	95.3	15156	2515	2.3°
4	400000	2353	400185	2352	7021	2352	11367	1453	400000	71.5	11367	2516	1.7°
3	400000	2353	400082	2352	4681	2352	7578	1453	400000	47.7	7578	2517	1.2°
2	400000	2353	400021	2353	2340	2353	3789	1453	400000	23.8	3789	2517	0.6°
1	400000	2353	400000	2353	0	2353	0	1453	400000	0	0	2517	0°

$$\begin{bmatrix} I_{d\_L1} \\ I_{d\_L2} \\ I_{d\_L3} \end{bmatrix} = \frac{1}{2353} \cdot M(0^\circ) \cdot \begin{bmatrix} I_{L1\_S} \\ I_{L2\_S} \\ I_{L3\_S} \end{bmatrix} + \frac{1}{2257} \cdot M(-16.4^\circ) \cdot \begin{bmatrix} I_{L1\_L} \\ I_{L2\_L} \\ I_{L3\_L} \end{bmatrix} \quad (2.1)$$

In a similar way this matrix equation can be written for any OLTC position if appropriate values from Figure 3 are given for the base current and the phase angle shift on the load side of the PST.

## 4 Conclusion

The presented method can be used to calculate differential currents for arbitrary, three-phase power transformers. The method is not dependent on individual winding connection details (i.e. star, delta, zigzag), but it might be dependent on correct information regarding the actual OLTC position. On-line reading of the OLTC position and compensation for phase current magnitude variations caused by OLTC movement has been used for numerical power transformer differential protection relays since 1998 [1]. This approach has shown an excellent track record and is the de-facto industry standard in many countries. In this paper the

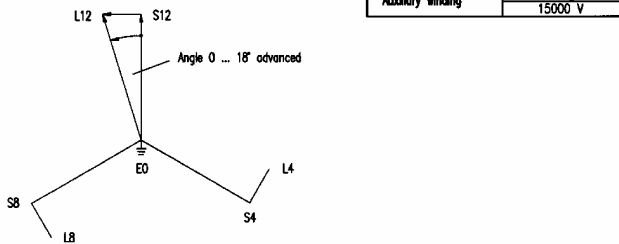

Figure 3: Part of the PST rating plate.

feasibility of advanced on-line compensation for non-standard or variable phase angle shifts across a power transformer has been demonstrated. Thus, differential protection for an arbitrary three-phase power transformer can be provided. By doing so, simple but effective differential protection for special converter transformers and PSTs can be achieved. Such application is very similar to already well-established numerical differential protection relays for standard power transformers [1,2]. The only difference is that elements of MX matrices used to provide the phase angle shift compensation and optional zero sequence current elimination are not standard or fixed, but instead dynamically calculated based on the actual OLTC position. Due to the relatively slow operating sequence of the OLTC, these matrix elements can be computed within the differential relay on a slow cycle (e.g. once per second). That should not practically pose any additional burden on the processing capability of modern numerical differential protection relays [2].

By using this method the differential protection for arbitrary, three-phase power transformer will be ideally balanced for all symmetrical and non-symmetrical through-load conditions and external faults irrespective of transformer construction details and actual OLTC position. This differential protection method also eliminates any need for buried current transformers within power transformer tank as usually required by presently used PST differential protection schemes [4]. Note that inrush and overexcitation stabilization (e.g. 2nd and 5th harmonic blocking) is still required for such differential protection.

This method has been extensively tested by using disturbance files captured in actual PST installations and RTDS simulations based on practical PST data. All tests indicate excellent performance of this method for all types of external and internal faults. Previous publications regarding such differential protection could not be found. Thus, it seems that this work is unique and completely new in the field of protective relaying for power transformers.

## Acknowledgements

The author would like to acknowledge the discussions he had with Professor Sture Lindahl from Lund University, Lund-Sweden and Dr. Dietrich Bonmann from ABB AG-Transformatoren, Bad Honnef-Germany.

## References

- [1] ABB Document 1MRK 504 037-UEN, "Application Manual, RET 521\*2.5", ABB Automation Technology Products AB, Västerås, Sweden, (2003).
- [2] ABB Document 1MRK 504 086-UEN, "Technical reference manual, Transformer Protection IED RET 670", Product version: 1.1, ABB Power Technologies AB, Västerås, Sweden, (2007).
- [3] Z. Gajić. "Differential Protection Solution for Arbitrary Phase Shifting Transformer", International Conference on Relay Protection and Substation Automation of Modern EHV Power Systems, Moscow – Cheboksary, Russia, (2007).
- [4] IEEE Special Publication, "Protection of Phase Angle Regulating Transformers (PAR)", A report to the Substation Subcommittee of the IEEE Power System Relaying Committee prepared by Working Group K1, (1999).
- [5] International Standard IEC 60076, "Power transformers", First edition, (1997).
- [6] International Standard IEC 61378-3, "Converter Transformers – Application Guide", First edition (2006).
- [7] International Standard IEC 62032/IEEE C57.135. "Guide for the application, specification, and testing of phase-shifting transformers", First edition (2005).
- [8] Westinghouse Electric Corporation, "Electrical Transmission and Distribution Reference Book", 4<sup>th</sup> edition, pp. 44–60, East Pittsburgh, USA (1950).