

# Protection Terminals and Relay REF 54\_, RET 54\_, REX 521

DNP 3.0 Communication Protocol

Technical Description





---

## Contents

<b>1. About this manual .....</b>	<b>4</b>
1.1. Copyrights .....	4
1.2. Trademarks .....	4
1.3. General .....	4
1.4. Abbreviations .....	5
1.5. Related documents .....	5
1.6. Document revisions .....	6
<b>2. Overview of the Protocol .....</b>	<b>7</b>
2.1. Physical layer .....	7
2.2. Data link layer .....	7
2.3. Transport pseudo-layer .....	8
2.4. Application layer .....	8
<b>3. Interface configuration .....</b>	<b>9</b>
3.1. Configuring REF 54_ and RET 54_ .....	9
3.2. Configuring REX 521 .....	10
3.3. Protocol mapping .....	10
3.3.1. General guidelines on how application data is seen on the DNP 3.0 protocol .....	11
3.3.2. Protocol mapping diagnostics .....	13
3.3.3. DNP_3, internal indications .....	13
3.4. Protocol parameters .....	14
3.5. Time Synchronization .....	17
3.6. Event handling .....	17
3.6.1. Event buffer overflow .....	17
3.7. Collision avoidance and detection .....	18
<b>4. Appendix A: Profile checklist for REF 54_ and RET 54_ .....</b>	<b>19</b>
<b>5. Appendix B: Profile Checklist REX 521 .....</b>	<b>29</b>
<b>6. Appendix C: Examples of mapping application data into the DNP 3.0 protocol .....</b>	<b>39</b>
6.1. COIND1, switch state mapping .....	40
6.2. NOC3Low, state of protection signal .....	41
6.3. COCB1, control command mapping .....	41
6.4. CMBWEAR1, control command on software binary point .....	42
6.5. BIO1, binary input change counter (REF 54_ and RET 54_) .....	42
6.6. MECU1A, mapping of analog input with limit and delta supervision .....	42
6.7. CMBWEAR1, electric wear measurement .....	43
6.8. DNP_3, device clock .....	43

---

## 1. About this manual

### 1.1. Copyrights

The information in this document is subject to change without notice and should not be construed as a commitment by ABB Oy. ABB Oy assumes no responsibility for any errors that may appear in this document.

In no event shall ABB Oy be liable for direct, indirect, special, incidental or consequential damages of any nature or kind arising from the use of this document, nor shall ABB Oy be liable for incidental or consequential damages arising from use of any software or hardware described in this document.

This document and parts thereof must not be reproduced or copied without written permission from ABB Oy, and the contents thereof must not be imparted to a third party nor used for any unauthorized purpose.

The software or hardware described in this document is furnished under a license and may be used, copied, or disclosed only in accordance with the terms of such license.

Copyright © 2005 ABB Oy  
All rights reserved.

### 1.2. Trademarks

ABB is a registered trademark of ABB Group.

All other brand or product names mentioned in this document may be trademarks or registered trademarks of their respective holders.

### 1.3. General

This manual describes how the Distributed Network Protocol (DNP) 3.0 and its parameterization are implemented in the REF 541/543/545 Feeder Terminals, the RET 541/543/545 Transformer Terminals and the REX 521 Protection Relays.

This manual is valid for REF 54\_ and RET 54\_, Release 3.0 and later, and for REX 521, Release E and later.

## 1.4. Abbreviations

CTO	Common Time of Occurrence
DFC	Data Flow Control
DNP	Distributed Network Protocol
EPA	Enhanced Performance Architecture
FCB	Flow Control Bit
HMI	Human-Machine Interface
IEC	International Electrotechnical Commission
ISO	International Organization for Standardization
OSI	Open System Interconnection
POD	Protocol Object Dictionary
PMT	Protocol Mapping Tool
RTU	Remote Terminal Unit
SDU	Service Data Unit

## 1.5. Related documents

Name of the manual	MRS number
<b>General Manuals</b>	
Installation Manual	1MRS750526-MUM
Technical Descriptions of Functions (CD-ROM)	1MRS750889-MCD
<b>Manuals for REF 54_ and RET 54_</b>	
RE_ 54_ Operator's Manual	1MRS750500-MUM
Protection & Control Terminals REF 54_, RET 54_, REM 54_, REC 523 Configuration Guideline	1MRS750745-MUM
Bus Connection Module RER 123, Technical Description	1MRS751143-MUM
Bus Connection Module RER 133, Technical Description	1MRS755163
<b>Manuals for REF 54_</b>	
Technical Reference Manual, General	1MRS750527-MUM
<b>Parameter and event lists for REF 54_</b>	
Parameter List for REF 541 and REF 543	1MRS751774-RTI
Parameter List for REF 545	1MRS751775-RTI
Event List for REF 541 and REF 543	1MRS751776-RTI
Event List for REF 545	1MRS751777-RTI
<b>Manuals for RET 54_</b>	
Technical Reference Manual, General	1MRS755225
<b>Parameter and event lists for RET 54_</b>	
Parameter List for RET 541 and RET 543	1MRS755228
Parameter List for RET 545	1MRS755229
Event List for RET 541 and RET 543	1MRS755226
Event List for RET 545	1MRS755227
<b>Manuals for REX 521</b>	
Operator's Manual	1MRS 751107-MUM
Technical Reference Manual, General	1MRS 751108-MUM
Technical Reference Manual, Standard Configurations	1MRS 751802-MUM

<b>Parameter and event lists for REX 521</b>	
Parameter List for REX 521	1MRS 751999-RTI
Event List for REX 521	1MRS 752000-RTI
General Parameters for REX 521	1MRS 752156-RTI
Interoperability List for REX 521	1MRS 752157-RTI
<b>Tool-specific manuals</b>	
CAP505 Installation and Commissioning Manual	1MRS751901-MEN
CAP505 User's Guide	1MRS752292-MUM
CAP505 Protocol Mapping Tool, Operation Manual	1MRS755277
LIB, CAP, SMS, Tools for Relays and Terminals, User's Guide	1MRS752008-MUM
CAP 501 Installation and Commissioning Manual	1MRS751899-MEN
CAP 501 User's Guide	1MRS751900-MUM

**1.6.**

**Document revisions**

<b>Version</b>	<b>Date</b>	<b>History</b>
A	2.4.2004	
B	18.5.2004	Parameter F503V025 updated. Profile checklist updated.
C	22.6.2004	REX 521 added to manual.
D	20.01.2005	RET 54_ added to manual.
E	08.07.2005	RER 123 fibre-optic support added.

---

## 2. Overview of the Protocol

The DNP 3.0 protocol was developed by Harris Controls based on the early versions of the IEC 60870-5 standard telecontrol protocol specifications. Now the protocol specification is controlled by the DNP Users Group.

The International Standard Organization (ISO) Open System Interconnection (OSI) based model supported by this protocol specifies physical, data link and application layers only. This reduced protocol stack is referred to as Enhanced Performance Architecture (EPA). However, to support advanced Remote Terminal Unit (RTU) functions and messages larger than the maximum frame length as defined by the International Electrotechnical Commission (IEC) document 60870-5-1, the DNP 3.0 Data Link is intended to be used with a transport pseudo-layer. As a minimum, this transport layer implements message assembly and disassembly services.

### 2.1. Physical layer

The physical layer that is recommended for the data link is a bit-serial oriented asynchronous physical layer supporting 8-bit data, 1 start bit, 1 stop bit, and no parity.

REF 54\_ and RET 54\_ can be connected to a fibre-optic system using the RER 123 Bus Connection Module, or to a 2- or 4-wire RS-485 system using the RER 133 Bus Connection Module. REX 521 can be connected directly to a 2-wire or a fibre-optic RS-485 system using the built-in ports.

For extended information on the DNP 3.0 physical layer, see the document “DNP Users Group: DNP V3.00 Link Layer Protocol Description”, Network File Name: P009-0PD.DL. This document is available from the DNP Users Group, Internet: [www.dnp.org](http://www.dnp.org).

### 2.2. Data link layer

The DNP 3.0 data link layer is designed to operate with connection-oriented and connectionless asynchronous or synchronous bit serial physical layers. Fully balanced transmission procedures were adopted to support spontaneous transmissions from outstations.

#### Data link functions

- Performing message retries.
- Synchronizing and handling of the Flow Control Bit (FCB) in the control octet.
- Setting and clearing the Data Flow Control bit (DFC) based on buffer availability.
- Packing user data into the defined frame format and transmitting the data to the physical layer.
- Unpacking the frames that are received from the physical layer into user data.
- Controlling all aspects of the physical layer.
- Performing collision avoidance/detection procedures to ensure reliable transfer of data across the physical link.
- Responding to all valid frames (function codes) received from the physical layer.

### **Data link responsibilities**

- Exchange of Service Data Units (SDUs) between peer DNP 3.0 data links.
- Error notification to data link user.
- Sequencing of SDUs.
- Quality SDU delivery.

Quality delivery can be SEND-NO-REPLY or SEND-CONFIRM to indicate whether or not a message acknowledgement is required.

## **2.3.**

### **Transport pseudo-layer**

To support advanced RTU functions and messages exceeding the maximum frame length, a transport pseudo-layer which implements message assembly and disassembly services was adopted.

This pseudo-layer is actually a super-data link transport protocol, which is normally included in some OSI data links.

#### **Transport functions**

- Packing user data into one or more frames of the defined DNP 3.0 data link frame format and transmitting the data to the data link layer.
- Unpacking multiple frames that are received from the data link layer into user data.
- Controlling all aspects of the data link excluding data link configuration.

#### **Transport responsibilities**

- Exchange of SDUs between peer DNP 3.0 transport pseudo layers.
- Error notification to transport user.
- Sequencing of SDUs.

## **2.4.**

### **Application layer**

The application layer is responsible for performing operations on data objects defined by the device or on the device itself. These operations can be: returning actual values (read function), assigning new values (write function) if the object represents control points, arming and energizing the output point (select, operate or direct operate functions) and if counters are used, storing actual values (freeze functions) and clearing the counters. There are also several functions controlling the device or the state of the application (e.g. reset device function).

All data objects are assigned to classes. The DNP 3.0 protocol defines four classes. In REF 54\_, RET 54\_ and REX 521 class 0 is used for static data, class 1 for binary input change events, class 2 for analog change events and class 3 for counter events. Only static data (assigned to class 0) is always available and can be interrogated using the read function.

An outstation can spontaneously generate messages called unsolicited responses to report event data without being polled by the master station.



### 3. Interface configuration

This section describes the communication parameters required to configure REF 54\_, RET 54\_ and REX 521 to communicate using the DNP 3.0 protocol.

The DNP 3.0 protocol can be used only when the protocol is properly configured.

#### 3.1. Configuring REF 54\_ and RET 54\_

The DNP 3.0 protocol must be selected in CAP 505 as an add-on protocol. For additional information, refer to the CAP 505 Operator's Manual.

When the protocol is selected and the relay configuration is created or modified (for additional information, refer to Relay Configuration Tool in CAP 505), the protocol mapping must be created or modified using Protocol Mapping Tool (PMT). The protocol parameters (see "Protocol parameters" on page 14) are available only after the protocol is first selected and then activated. When the protocol mapping is first downloaded and stored in the relay, a reset of the relay activates the protocol.

The protocol parameters can be uploaded, reviewed and modified using the Relay Setting Tool from the CAP 501/505 package by choosing the Communication library and the DNP 3.0 pages.

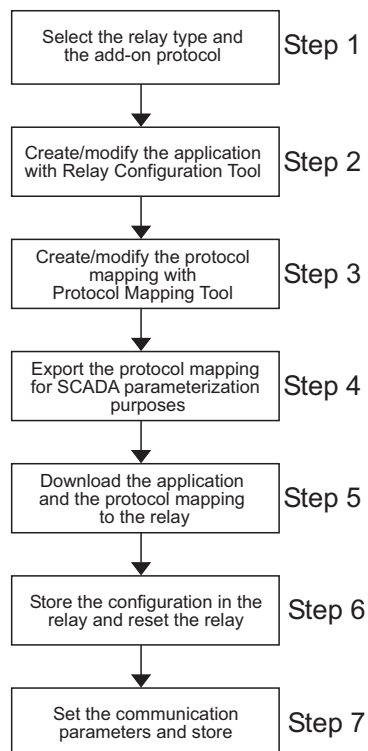

A050344

*Fig. 3.1.-1 REF 54\_ and RET 54\_ interface configuration*

If the application is changed, start over from step 2.

If you wish to keep the existing protocol mapping, select a new name for the protocol mapping or skip step 3.

If you modify the application and after that create a new protocol mapping with the wizard, the protocol mapping addresses will be changed.

Application downloading overwrites existing add-on protocol parameters and protocol mapping. A backup of parameters can be created using the Relay Setting Tool in CAP 505.

### 3.2. **Configuring REX 521**

REX 521 comes with a standard protocol mapping installed. This mapping can be modified with Protocol Mapping Tool (see “Related documents” on page 5).

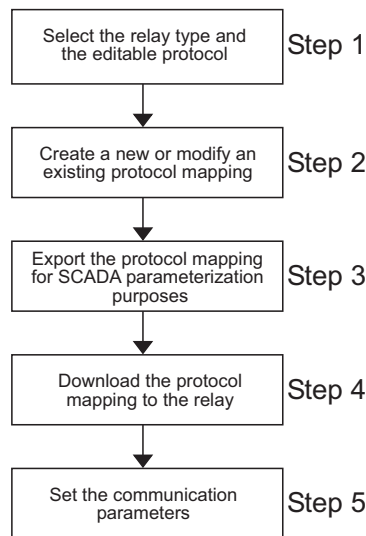

A050345

*Fig. 3.2.-1 REX 521 interface configuration*

If no modification to the standard protocol mapping is required, the only action needed to do to get the protocol functioning is to select the proper rear port protocol and to set the communication parameters. The protocol parameters are described in section “Protocol parameters” on page 14.

### 3.3. **Protocol mapping**

Protocol mapping is a cross-reference table between the application and the remote control protocol, e.g. DNP 3.0. This table defines what information can be accessed using the protocol interface.

As REF 54\_ and RET 54\_ are programmable and may run various application setups with different combinations of function blocks, the protocol mapping is fully reconfigurable.

REX 521 has standard configurations for different applications. However, the protocol mapping can be modified by the user.

Protocol mapping can be referred to as Protocol Object Dictionary or POD in REC 523 and earlier REX 521 product documentation.

**3.3.1. General guidelines on how application data is seen on the DNP 3.0 protocol**

Fig. 3.3.1.-1 in this section describes how the process data in a relay is seen on the DNP 3.0 protocol.

In the application example below, all the possible process data is present. The boxes show to which DNP 3.0 data category the signals belong.

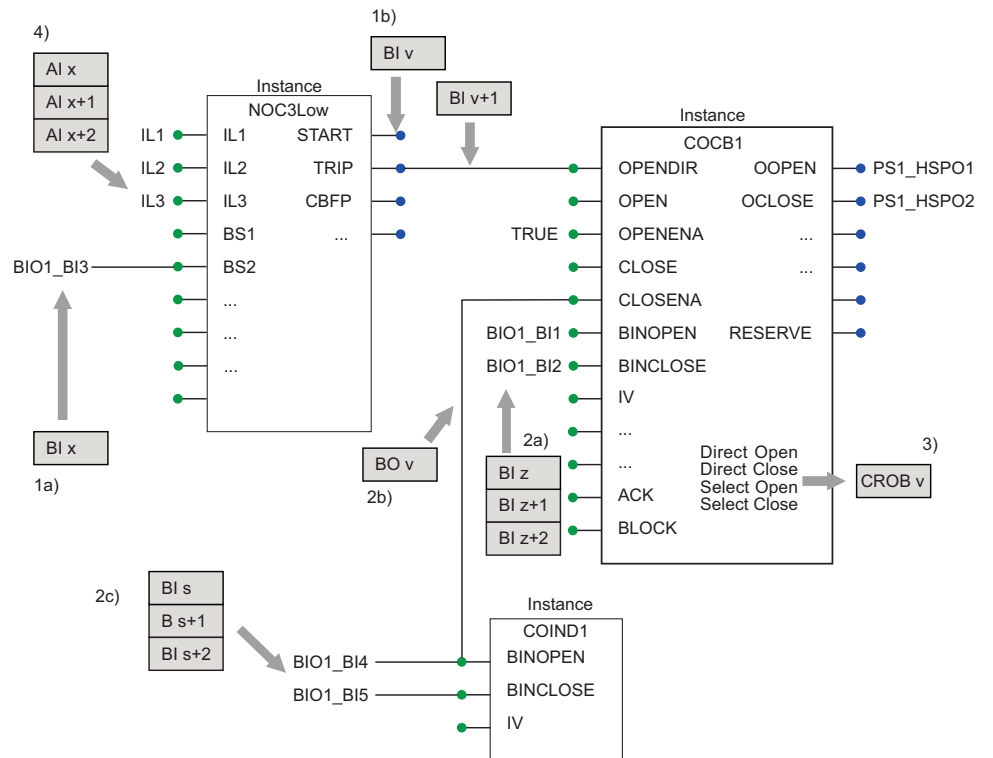

A050346

Fig. 3.3.1.-1 Mapping example, explained in the following table

**Table 3.3.1-1 Explanations to Fig. 3.3.1.-1**

No	Application data type	Explanation	DNP 3.0 data type
1a)	One Bit Input	Binary input to a function block, e.g. blocking input.	Binary input (object 1). Changes are also reported as Binary input change event (object 2).
1b)	One Bit Input	Binary output from function block, e.g. START or TRIP signals.	Binary input (object 1). Changes are also reported as Binary input change event (object 2).
2a)	Two Bit Input	Binary position data coded in two bits (OPEN, CLOSE).	Three consecutive binary inputs (object 1). Value is coded as follows: BI z: OPEN BI z+1: CLOSED BI z+2: Faulty Value 1 indicates current switch position. When all points are 0s switch is in intermediate position. Changes are also reported as Binary input change events (object 2).
2b)	Two Bit Input	In addition to 2a): If this is a position indication of a breaker or a disconnecter, that can be remotely operated via DNP, the position is mapped as binary output with point index, matching control relay output block used for remote control.	Binary output object (10). Value is coded as follows: OPEN: OnLine 1 CLOSED: OnLine 0 Intermediate: OffLine 0 Faulty: OffLine 1 Note: point index must be same as in 3).
2c)	Two bit input	In addition to 2a): If this position indicates the state of a device, that can be controlled remotely via DNP, the position is mapped as binary output with point index, matching control relay output block used for remote control.	Binary output object (10). Value is coded as follows: OPEN: OnLine 1 CLOSED: OnLine 0 Intermediate: OffLine 0 Faulty: OffLine 1 Note: point index must be same as in 3).
3)	Control output points	Relay controlled from the DNP 3.0 master.	Control relay output block (object 12). On point of this object following protocol functions can be performed: Select Operate Direct open Direct close Note: point number must be the same as in 2b).
4)	Measurement inputs	Measurement inputs to the function blocks.	
Not visible in the figure	Counters	Counters of operations from I/O cards.	Binary counter (object 20). Changes are also reported as Binary counter change events (object 32.)
Not visible in the figure	Parameters, settings, etc.	Some parameters of the device and function blocks may be adjustable.	Analog output status (object 40) for reading. Analog output block (object 41) for setting. (Available functions: Select, Operate, Direct open, Direct close.)

### 3.3.2. Protocol mapping diagnostics

The protocol mapping table that is downloaded into the unit has an identification string. The identification string is used to check the consistency between the protocol mapping stored into the relay and the protocol mapping opened by the Protocol Mapping Tool. Refer to Protocol Mapping Tool Operator's Manual (see "Related documents" on page 5) for further information.

### 3.3.3. DNP\_3, internal indications

Internal indications are binary points containing information on device status. The mapping of the internal indications is as follows:

<b>LSB</b>	<b>Device status</b>
IIN1.0	This bit is set when a request is received with the destination address of the All Stations address (0x0FFF)
IIN1.1	The relay has Class 1 events to send to the master
IIN1.2	The relay has Class 2 events to send to the master
IIN1.3	The relay has Class 3 events to send to the master
IIN1.4	Time-synchronization is required from the master. (Configured in parameter F503V025)
IIN1.5	Control position is Local/Disabled
IIN1.6	An abnormal condition exists in the relay
IIN1.7	This bit is set when the unit restarts
<b>MSB</b>	
IIN2.0	Function code not supported
IIN2.1	Requested object(s) unknown. The device does not have the specified objects or there are no objects assigned to the requested class
IIN2.2	Parameters in the qualifier, range or data fields are not valid or out of range
IIN2.3	Event buffer overflow
IIN2.4	Request understood but requested operation is already executing
IIN2.5	Current configuration corrupt
IIN2.6	Reserved 1
IIN2.7	Reserved 2

### 3.4. Protocol parameters

The DNP 3.0 protocol parameters can be accessed by choosing the communication library and the DNP 3.0 pages in the Relay Setting Tool or by means of a local HMI by selecting Configuration\Communication\Comm.settings\DNP.

Parameter name	DB name REF 54_ RET 54_	DB name REX 521	Values	Default	Visible	Read/ write	Explanation
Unit address	F503V001	F503V001	0...65532	1	HMI, SPA	R/W	Address of the relay in the DNP 3.0 network. Must be the same as configured in the master station.
Master address	F503V002	F503V002	0...65532	2	HMI, SPA	R/W	Address of the master station (destination address for unsolicited responses). Must be the same as configured in the master station.
Primary data link timeout	F503V003	F503V003	100...10000 [ms] <sup>1)</sup>	300	HMI, SPA	R/W	The timeout that is used when the relay sends data using service 3 (user data with confirmation). The timeout must be set according to the communication speed.
Primary data link layer retransmission count	F503V004	F503V004	0...100	0	HMI, SPA	R/W	The number of retransmissions on the data link layer when the relay sends spontaneous data.
Application layer timeout	F503V006	F503V006	1000...10000 [ms] <sup>1)</sup>	1000	HMI, SPA	R/W	The timeout that is used when the relay sends messages with confirmation request. The timeout must be set according to the communication speed.
Application layer retransmission count	F503V007	F503V007	0...100	0	HMI, SPA	R/W	The number of retransmissions on the application layer when the relay sends messages with confirmation request.
Confirmation on data link layer	F503V008	F503V008	0...1 [0=disabled; 1=enabled]	0	HMI, SPA	R/W	Enable/disable confirmations on the data link layer.
Confirmation on application layer	F503V009	F503V009	0...1 [0=disabled; 1=enabled]	0	HMI, SPA	R/W	Enable/disable confirmations on the application layer.
Default variation of binary input object	F503V010	F503V010	1...2	2	HMI, SPA	R/W	
Default variation of binary input change event object	F503V011	F503V011	1...3	2	HMI, SPA	R/W	
Default variation of binary output object	F503V012	F503V012	1...2	2	HMI, SPA	R/W	
Default variation of counter object	F503V013	F503V013	1...2	1	HMI, SPA	R/W	
Default variation of counter event object	F503V014	F503V014	1...2	1	HMI, SPA	R/W	
Default variation of analog input object	F503V015	F503V015	1...2	1	HMI, SPA	R/W	
Default variation of analog input event object	F503V016	F503V016	1...2	1	HMI, SPA	R/W	
Default variation of analog output status object	F503V017	F503V017	1...2	1	HMI, SPA	R/W	
Class1 event delay	F503V018	F503V018	0...1000 [s]	1	HMI, SPA	R/W	The delay for spontaneous event reporting for class 1

**Protection Terminals and Relay**  
**DNP 3.0 Communication Protocol**  
 Technical Description

Parameter name	DB name REF 54_ RET 54_	DB name REX 521	Values	Default	Visible	Read/ write	Explanation
Class1 event count	F503V019	F503V019	1...32	1	HMI, SPA	R/W	The event count for spontaneous event reporting for class 1
Class2 event delay	F503V020	F503V020	0...1000 [s]	1	HMI, SPA	R/W	The delay for spontaneous event reporting for class 2
Class2 event count	F503V021	F503V021	1...32	1	HMI, SPA	R/W	The event count for spontaneous event reporting for class 2
Class3 event delay	F503V022	F503V022	0...1000 [s]	1	HMI, SPA	R/W	The delay for spontaneous event reporting for class 3
Class3 event count	F503V023	F503V023	1...32	1	HMI, SPA	R/W	The event count for spontaneous event reporting for class 3
Unsolicited reporting mode <sup>2)</sup>	F503V024	F503V024	0...3 [0=unsolicited responses are disabled; 1=send messages immediately; 2 =first send empty UR and wait for confirmation, then send data filled URs; 3=first send empty UR and wait for confirmation, wait for enable UR from master and then send data filled URs]	0	HMI, SPA	R/W	Unsolicited messages reporting behavior
Time synchronization mode	F503V025	F503V025	0...2 [0=Never; 1=Startup; 2=Periodic]	2	HMI, SPA	R/W	See "Time Synchronization" on page 17
Baud rate	F503V211	F503V211	0...6 [0=300; 1=600; 2=1200; 3=2400; 4=4800; 5=9600; 6=19200]	5	HMI, SPA	R/W	The communication speed of the DNP 3.0 protocol
Number of stop bits	F503V212	F503V212	1...2	1	HMI, SPA	R/W	
Next character timeout	F503V215	F503V215	0...65535 [ms] <sup>1)</sup>	0	HMI, SPA	R/W	
End of frame timeout	F503V216	F503V216	2...65535 [ms] <sup>1)</sup>	10	HMI, SPA	R/W	
Parity	F503V230	F503V230	0...2 [0=None; 1=Odd; 2=Even]	0	HMI, SPA	R/W	
Silent interval	F503V232	F503V232	10...65535 [ms]	20	HMI, SPA	R/W	See "Collision avoidance and detection" on page 18
Time slot width	F503V233	F503V233	10...65535 [ms]	10	HMI, SPA	R/W	See "Collision avoidance and detection" on page 18
Number of time slots	F503V234	F503V234	1...255	8	HMI, SPA	R/W	See "Collision avoidance and detection" on page 18
Collision detection enabled	F503V235		0...1 [0=Disabled; 1=Enabled]	0	HMI, SPA	R/W	Enable/disable collision detection

Parameter name	DB name REF 54_ RET 54_	DB name REX 521	Values	Default	Visible	Read/ write	Explanation
Collision avoidance enabled		F503V236	0...1 [0=Disabled; 1=Enabled]	0	HMI, SPA	R/W	Enable/disable collision avoidance
Protocol mapping diagnostic parameter	F503M001	F503M001			SPA	R/W	DNP protocol mapping file
Protocol mapping diagnostic parameter	F503V060	F503V060			SPA	R	Counter for total entries
Protocol mapping diagnostic parameter	F503V061	F503V061			SPA	R	The number of entries not in use
Protocol mapping diagnostic parameter	F503V062	F503V062			SPA	R	The number of entries with invalid, uncorrectable contents
Protocol mapping diagnostic parameter	F503V063	F503V063			SPA	R	The number of entries with corrected contents
Protocol mapping diagnostic parameter	F503V064	F503V064			SPA	R	The number of entries referring to a nonexistent block
Protocol mapping diagnostic parameter	F503V065	F503V065			SPA	R	The number of entries referring to invalid objects of an existing block
Protocol mapping diagnostic parameter	F503V066	F503V066			SPA	R	The number of entries translated into the protocol mapping
Protocol mapping diagnostic parameter	F503V700	F503V700			SPA	R/W	The name of the protocol mapping
Collision counter	F503V260		0...65535	0	HMI, SPA	R	See "Collision avoidance and detection" on page 18
Frame error counter	F503V261	F503V261	0...65535	0	SPA	R	
Parity error counter	F503V262	F503V262	0...65535	0	SPA	R	
Overrun error counter	F503V263	F503V263	0...65535	0	SPA	R	
Avoidance counter		F503V264	0...65535	0	SPA	R	See "Collision avoidance and detection" on page 18
Transmission counter		F503V265	0...65535	0	SPA	R	
Receive counter		F503V266	0...65535	0	SPA	R	

- 1) When using communication speeds below 1200 bits/s, be sure to set the values for parameters to values above the time it takes for one character to be sent. Note that if the values are not correctly set, the sent messages will be lost.
- 2) If parameter F503V024, Unsolicited reporting mode, is set to "0", the relay responds to an Enable unsolicited reporting request with the Internal indication IIN2.0 (Function code not supported) bit set.



---

### 3.5. Time Synchronization

Time synchronization is selected with parameter F503V025. The following time synchronization modes are supported:

- In time synchronization mode Never, time sync is never requested from the master. If the master sends time sync it is received, but not used to synchronise the relay.
- In time synchronization mode Periodic, time sync is requested from the master every minute. If the master spontaneously sends time sync, time is received and used to synchronise the relay.
- In time synchronization mode Startup, time sync is requested from the master only at startup. If the master spontaneously sends time sync, time is received and used to synchronise the relay.

The recommendation is to use Startup mode together with Binary input time synchronization. For information on Binary input time synchronization, see REF 54\_ Technical Reference Manual, General, RET 54\_ Technical Reference Manual, General or REX 521 Technical Reference Manual, General (see “Related documents” on page 5).

### 3.6. Event handling

The DNP 3.0 Event buffer is limited to 100 events. Unsolicited responses are enabled through parameter F503V024. When unsolicited responses are enabled, the event reporting uses the following parameters:

F503V018, Class 1 event delay  
F503V019, Class 1 event count  
F503V020, Class 2 event delay  
F503V021, Class 2 event count  
F503V022, Class 3 event delay  
F503V023, Class 3 event count

When unsolicited responses are enabled, the events for e.g. Class 1 are reported to the master when:

- the amount of events defined in the event count parameter has occurred (for Class 1, parameter F503V019)

or

- the time defined in the event delay parameter has elapsed (for Class 1, parameter F503V018)

#### 3.6.1. Event buffer overflow

Event buffer overflow is indicated with the Internal indication IIN2.3 as defined in the document "DNP V3.00 Application Layer Protocol Description, P009-0PD.APP". In addition to DNP 3.0 event buffer overflow, IIN 2.3 can be set because of a temporary delay in the internal message passage system. In this case bit IIN2.3 is reset automatically when the system returns to normal operation.

In all cases, the DNP 3.0 master should perform a class 0 scan after IIN2.3 is reset.

3.7.

**Collision avoidance and detection**

Collision avoidance works before message transmission. When the relay prepares to transmit, it first waits until the link is not busy, and then waits a backoff\_time. The backoff\_time is calculated as follows:

$$\text{backoff\_time} = \text{fixed\_delay} + \text{random}(\text{max\_random\_delay})$$

After the backoff\_time the relay checks that the link is not busy and then starts to transmit.

The fixed delay is set with parameter F503V232, Silent interval. The maximum random delay is calculated using two parameters, F503V233, which defines the width of a single time slot in milliseconds, and F503V234, which defines the maximum number of time slots. E.g. setting time slot width to 10 ms and time slot count to 10 defines the maximum random delay to 100 ms. Note that in a system configuration, these parameters define the priority of the devices. A device with short Silent interval and small Maximum random delay has a higher priority than a device using a longer Silent interval and Maximum random delay.

REX 521 supports collision avoidance. The parameter F503V236 is used to set the collision avoidance, 1=enabled, 0=disabled.

REF 54\_ and RET 54\_ support both collision avoidance and detection. Collision avoidance and detection require the use of the RER 133 Bus Connection Module.

Collision detection is enabled and disabled by setting parameter F503V235, 1 = enabled, 0 = disabled.

Collision detection is used during the transmission. While sending a message, REF 54\_ and RET 54\_ supervise the collisions on the link. When a collision is detected on the link, REF 54\_ and RET 54\_ immediately cancel the transmission. Then REF 54\_ and RET 54\_ try to retransmit the message, again using collision avoidance before sending the message.

Note: Collision avoidance and detection in REF 54\_ and RET 54\_ require the use of the RER 133 and the setting of communication speed to 4800, 9600 or 19200 bits/s. With lower communication speeds, even if collision detection is enabled by parameter setting, it will not work properly. If some other bus connection module than RER 133 is used, the collision avoidance and detection will not work.

In a system all devices should use collision avoidance when unsolicited responses are used.

#### 4. **Appendix A: Profile checklist for REF 54\_ and RET 54\_**

<b>DNP V3.00</b>	
<b>DEVICE PROFILE DOCUMENT</b>	
Vendor Name: ABB Oy, Distribution Automation Device Name: REF 54_ release 3.0 RET 54_ release 3.0	
Highest DNP Level Supported:  For Requests: L2 For Responses: L2	Device Function:  <input checked="" type="checkbox"/> Slave
Notable objects, functions, and/or qualifiers supported in addition to the Highest DNP Levels Supported (the complete list is described in the attached table): Additions to level 2 are marked as shaded in the implementation table	
Maximum Data Link Frame Size (octets):  Transmitted 292 Received 292	Maximum Application Fragment Size (octets):  Transmitted 2048 Received 2048
Maximum Data Link Re-tries: Configurable, range from 0 to 255 with primary data link layer retransmission count, parameter F503V004	Maximum Application Layer Re-tries: Configurable, range from 0 to 255 with application layer retransmission count, parameter F503V007
Requires Data Link Layer Confirmation: Configurable, with confirmation type selector, parameter F503V008	
Requires Application Layer Confirmation: <input checked="" type="checkbox"/> Configurable with confirmation type selector when reporting Event Data (Slave devices only) <input checked="" type="checkbox"/> Always after response to reset request <input type="checkbox"/> Always when sending multi-fragment responses (Slave devices only) <input checked="" type="checkbox"/> Configurable, with confirmation type selector, parameter F503V009	
Timeouts while waiting for:	
Data Link Confirm	Configurable with primary data link layer timeout (parameter F503V003), not relevant when no ACK
Complete Appl. Fragment	No, multi-fragment application frames not supported
Application Confirm	Configurable with application layer timeout, parameter F503V006
Complete Appl. Response	No, not relevant in slave

Sends/Executes Control Operations:	
WRITE Binary Outputs	<input type="checkbox"/> Never
SELECT/OPERATE	<input checked="" type="checkbox"/> Always
DIRECT OPERATE	<input checked="" type="checkbox"/> Always
DIRECT OPERATE - NO	<input checked="" type="checkbox"/> Always
Count	Always 1
Code	1, 2 or 3
Trip/Close	1,2 according to direction
Pulse On	Ignored
Queue	Always 0
Clear Queue	0 or 1
<b>FILL OUT THE FOLLOWING ITEMS FOR SLAVE DEVICES ONLY:</b>	
<p>Reports Binary Input Change Events when no specific variation requested:</p> <input type="checkbox"/> Never <input type="checkbox"/> Only time-tagged <input type="checkbox"/> Only non-time-tagged <input checked="" type="checkbox"/> Configurable to send both, one or the other (parameter F503V011)	<p>Reports time-tagged Binary Input Change Events when no specific variation requested:</p> <input type="checkbox"/> Never <input type="checkbox"/> Binary Input Change With Time <input type="checkbox"/> Binary Input Change With Relative Time <input checked="" type="checkbox"/> Configurable (parameter F503V011)
<p>Sends Unsolicited Responses:</p> <input type="checkbox"/> Never <input checked="" type="checkbox"/> Configurable <input type="checkbox"/> Only certain objects <input type="checkbox"/> Sometimes (attach explanation) <input checked="" type="checkbox"/> ENABLE/DISABLE <b>UNSOLICITED</b> Function codes supported	<p>Sends Static Data in Unsolicited Responses:</p> <input checked="" type="checkbox"/> Never <input type="checkbox"/> When Device Restarts <input type="checkbox"/> When Status Flags Change No other options are permitted.
<p>Default Counter Object/Variation:</p> <input type="checkbox"/> No Counters Reported <input type="checkbox"/> Configurable, default object and variation <input checked="" type="checkbox"/> Default Object 20 <input checked="" type="checkbox"/> Default Variation 1 <input type="checkbox"/> Point-by-point list attached	<p>Counters Roll Over at:</p> <input type="checkbox"/> No Counters Reported <input type="checkbox"/> Configurable (attach explanation) <input type="checkbox"/> 16 Bits <input checked="" type="checkbox"/> 32 Bits, but roll-over bits not used <input type="checkbox"/> Other Value _____ <input type="checkbox"/> Point-by-point list attached
Sends Multi-Fragment Responses: <input type="checkbox"/> Yes <input checked="" type="checkbox"/> No	

### Supported function codes

CODE	FUNCTION	DESCRIPTION	Supported
<b>Transfer Function Codes</b>			
0	Confirm	Message fragment confirmation No response	Yes
1	Read	Request objects from outstation Respond with requested objects	Yes
2	Write	Store specified objects to outstation Respond with status of operation	Yes
<b>Control Function Codes</b>			
3	Select	Select output point of outstation Respond with echo of request and status of control point	Yes
4	Operate	Set output that has previously selected Respond with status of control point	Yes
5	Direct operate	Set output directly Respond with status of control point	Yes
6	Direct operate - no ack	Set output directly No response	Yes
<b>Freeze Function Codes</b>			
7	Immediate Freeze	Copy specified objects to freeze buffer Respond with status of operation	Yes
8	Immediate Freeze -no ack	Copy specified objects to freeze buffer No response	Yes
9	Freeze and Clear	Copy specified objects to freeze buffer and clear objects Respond with status of operation	Yes
10	Freeze and Clear -no ack	Copy specified objects to freeze buffer and clear objects No response	Yes
11	Freeze with time	Copy specified objects to freeze buffer at specified time Respond with status of operation	Yes
12	Freeze with time -no ack	Copy specified objects to freeze buffer at specified time No response	Yes
<b>Application Control Function Codes</b>			
13	Cold Restart	Perform desired reset sequence Respond with a time object	Yes
14	Warm Restart	Perform desired partial reset operation Respond with a time object	Yes
15	Initialise Data to Defaults	Initialise the specified data to default Respond with status of operation	No
16	Initialise Application	Ready the specified application to run Respond with status of operation	No
17	Start Application	Start the specified application to run Respond with status of operation	Yes
18	Stop Application	Stop the specified application to run Respond with status of operation	Yes

<b>Configuration Function Codes</b>			
19	Save configuration	Save configuration Respond with status of operation	No
20	Enable Unsolicited Messages	Enable Unsolicited Messages Respond with status of operation	Yes
21	Disable Unsolicited Messages	Disable Unsolicited Messages Respond with status of operation	Yes
22	Assign Class	Assign specified objects to a class Respond with status of operation	Yes
<b>Time Synchronization Function Codes</b>			
23	Delay Measurement	Perform propagation delay measurement	Yes
<b>Response Function Codes</b>			
0	Confirm	Message fragment confirmation	Yes
129	Response	Response to request message	Yes
130	Unsolicited Message	Spontaneous message without request	Yes

Note: REF 54\_ and RET 54\_ do not have Freeze Counters, even though the Freeze functions (7...12) are supported.

Note: When Multiple Object requests are used, the application layer timeout of the master device should be long enough for the relay to perform all the requested operations.

**Protection Terminals and Relay**  
**DNP 3.0 Communication Protocol**  
 Technical Description

**Supported objects:**

OBJECT			REQUEST (slave must parse)		RESPONSE (master must parse)	
Obj	Var	Description	Func Codes (dec)	Qual Codes (hex)	Func Codes (dec)	Qual Codes (hex)
1	0	Binary Input - All Variations	1, 22	all except 0B (and 06 with function 22)	129	00, 01
1	1	Binary Input	1, 22	all except 0B (and 06 with function 22)	129	00, 01 when all points were requested otherwise the same as in request
1	2	Binary Input with Status	1, 22	all except 0B (and 06 with function 22)	129	00, 01 when all points were requested otherwise the same as in request
2	0	Binary Input Change - All Variations	1	06, 07, 08	129, 130	17, 28
2	1	Binary Input Change without Time	1	06, 07, 08	129, 130	17, 28
2	2	Binary Input Change with Time	1	06, 07, 08	129, 130	17, 28
2	3	Binary Input Change with Relative Time	1	06, 07, 08	129, 130	17, 28
10	0	Binary Output - All Variations	1	all except 0B and 06	129, 130	00, 01
10	1	Binary Output	1	all except 0B	129	00, 01 when all points were requested otherwise the same as in request
10	2	Binary Output with Status	1	all except 0B	129	00, 01 when all points were requested otherwise the same as in request
12	0	Control Block - All Variations				
12	1	Control Relay Output Block	3, 4, 5, 6	17, 28	129	
12	2	Pattern Control Block				
12	3	Pattern Mask				
20	0	Binary Counter - All Variations	1, 7, 8, 9, 10, 11, 12, 22	all except 0B (and 06 with function 22)	129	00, 01
20	1	32-Bit Binary Counter	1, 2, 7, 8, 9, 10, 11, 12, 22	all except 0B (and 06 with functions 2 and 22)	129	00, 01 when all points were requested otherwise the same as in request
20	2	16-Bit Binary Counter	1, 2, 7, 8, 9, 10, 11, 12, 22	all except 0B (and 06 with functions 2 and 22)	129	00, 01 when all points were requested otherwise the same as in request
20	3	32-Bit Delta Counter				
20	4	16-Bit Delta Counter				

OBJECT			REQUEST (slave must parse)		RESPONSE (master must parse)	
Obj	Var	Description	Func Codes (dec)	Qual Codes (hex)	Func Codes (dec)	Qual Codes (hex)
20	5	32-Bit Binary Counter without Flag				
20	6	16-Bit Binary Counter without Flag				
20	7	32-Bit Delta Counter without Flag				
20	8	16-Bit Delta Counter without Flag				
21	0	Frozen Counter - All Variations				
21	1	32-Bit Frozen Counter				
21	2	16-Bit Frozen Counter				
21	3	32-Bit Frozen Delta Counter				
21	4	16-Bit Frozen Delta Counter				
21	5	32-Bit Frozen Counter with Time of Freeze				
21	6	16-Bit Frozen Counter with Time of Freeze				
21	7	32-Bit Frozen Delta Counter with Time of Freeze				
21	8	16-Bit Frozen Delta Counter with Time of Freeze				
21	9	32-Bit Frozen Counter without Flag				
21	10	16-Bit Frozen Counter without Flag				
21	11	32-Bit Frozen Delta Counter without Flag				
21	12	16-Bit Frozen Delta Counter without Flag				
22	0	Counter Change Event - All Variations	1	06, 07, 08	129,130	17, 28
22	1	32-Bit Counter Change Event without Time	1	06, 07, 08	129,130	17, 28
22	2	16-Bit Counter Change Event without Time	1	06, 07, 08	129,130	17, 28
22	3	32-Bit Delta Counter Change Event without Time				
22	4	16-Bit Delta Counter Change Event without Time				
22	5	32-Bit Counter Change Event with Time				
22	6	16-Bit Counter Change Event with Time				
22	7	32-Bit Delta Counter Change Event with Time				
22	8	16-Bit Delta Counter Change Event with Time				
23	0	Frozen Counter Event - All Variations				
23	1	32-Bit Frozen Counter Event without Time				



**Protection Terminals and Relay**  
**DNP 3.0 Communication Protocol**  
 Technical Description

OBJECT			REQUEST (slave must parse)		RESPONSE (master must parse)	
Obj	Var	Description	Func Codes (dec)	Qual Codes (hex)	Func Codes (dec)	Qual Codes (hex)
23	2	16-Bit Frozen Counter Event without Time				
23	3	32-Bit Frozen Delta Counter Event without Time				
23	4	16-Bit Frozen Delta Counter Event without Time				
23	5	32-Bit Frozen Counter Event with Time				
23	6	16-Bit Frozen Counter Event with Time				
23	7	32-Bit Frozen Delta Counter Event with Time				
23	8	16-Bit Frozen Delta Counter Event with Time				
30	0	Analog Input - All Variations	1, 22	all except 0B (and 06 with function 22)	129	00, 01
30	1	32-Bit Analog Input	1, 22	all except 0B (and 06 with function 22)	129	00, 01 when all points were requested otherwise the same as in request
30	2	16-Bit Analog Input	1, 22	all except 0B (and 06 with function 22)	129	00, 01 when all points were requested otherwise the same as in request
30	3	32-Bit Analog Input without Flag				
30	4	16-Bit Analog Input without Flag				
31	0	Frozen Analog Input - All Variations				
31	1	32-Bit Frozen Analog Input				
31	2	16-Bit Frozen Analog Input				
31	3	32-Bit Frozen Analog Input with Time of Freeze				
31	4	16-Bit Frozen Analog Input with Time of Freeze				
31	5	32-Bit Frozen Analog Input without Flag				
31	6	16-Bit Frozen Analog Input without Flag				
32	0	Analog Change Event - All Variations	1	06, 07, 08	129, 130	17, 28
32	1	32-Bit Analog Change Event without Time	1	06, 07, 08	129, 130	17, 28
32	2	16-Bit Analog Change Event without Time	1	06, 07, 08	129, 130	17, 28
32	3	32-Bit Analog Change Event with Time				
32	4	16-Bit Analog Change Event with Time				

OBJECT			REQUEST (slave must parse)		RESPONSE (master must parse)	
Obj	Var	Description	Func Codes (dec)	Qual Codes (hex)	Func Codes (dec)	Qual Codes (hex)
33	0	Frozen Analog Event - All Variations				
33	1	32-Bit Frozen Analog Event without Time				
33	2	16-Bit Frozen Analog Event without Time				
33	3	32-Bit Frozen Analog Event with Time				
33	4	16-Bit Frozen Analog Event with Time				
40	0	Analog Output Status - All Variations	1	all except 0B	129	00, 01
40	1	32-Bit Analog Output Status	1	all except 0B	129	00, 01 when all points were requested otherwise the same as in request
40	2	16-Bit Analog Output Status	1	all except 0B	129	00, 01 when all points were requested otherwise the same as in request
41	0	Analog Output Block - All Variations				
41	1	32-Bit Analog Output Block	3, 4, 5, 6	17, 28	129	
41	2	16-Bit Analog Output Block	3, 4, 5, 6	17, 28	129	
50	0	Time and Date - All Variations	1	all except 0B and 06	129	00, 01
50	1	Time and Date	1,2	all except 0B and 06	129	00, 01 when all points were requested otherwise the same as in request
50	2	Time and Date with Interval				
51	0	Time and Date CTO - All Variations				
51	1	Time and Date CTO <sup>1)</sup>	-	-	-	Sent only as part of message with events
51	2	Unsynchronized Time and Date CTO				Sent only as part of message with events
52	0	Time Delay - All Variations				
52	1	Time Delay Coarse			129	07
52	2	Time Delay Fine			129	07
60	0	Not defined				
60	1	Class 0 Data	1	06	129	00, 01
60	2	Class 1 Data	1, 20, 21	06 (06, 07, 08 with function 1)	129, 130	17, 28
60	3	Class 2 Data	1, 20, 21	06 (06, 07, 08 with function 1)	129, 130	17, 28

**Protection Terminals and Relay**  
**DNP 3.0 Communication Protocol**  
 Technical Description

**REF 54\_**  
**RET 54\_**  
**REX 521**

OBJECT			REQUEST (slave must parse)		RESPONSE (master must parse)	
Obj	Var	Description	Func Codes (dec)	Qual Codes (hex)	Func Codes (dec)	Qual Codes (hex)
60	4	Class 3 Data	1, 20, 21	06 (06, 07, 08 with function 1)	129, 130	17, 28
70	1	File Identifier				
80	1	Internal Indications	2 on point 4 and 7	all except 0B and 06	129	-
81	1	Storage Object				
82	1	Device Profile				
83	1	Private Registration Object				
83	2	Private Registration Object Descriptor				
90	1	Application Identifier	17, 18	06	129	-
100	1	Short Floating Point				
100	2	Long Floating Point				
100	3	Extended Floating Point				
101	1	Small Packed Binary-Coded Decimal				
101	2	Medium Packed Binary-Coded Decimal				
101	3	Large Packed Binary-Coded Decimal				
		No Object	13, 14			
		No Object	23			

1) If the "Time synchronization mode" parameter, F503V025, is set to Periodic or Startup, CTO will be unsynchronized until the first time synchronization. If the parameter is set to Never, CTO is always synchronized.



**5. Appendix B: Profile Checklist REX 521**

<b>DNP V3.00</b>	
<b>DEVICE PROFILE DOCUMENT</b>	
Vendor Name: ABB Oy, Distribution Automation Device Name: REX 521	
Highest DNP Level Supported:  For Requests: L2 For Responses: L2	Device Function:  <input checked="" type="checkbox"/> Slave
Notable objects, functions, and/or qualifiers supported in addition to the Highest DNP Levels Supported (the complete list is described in the attached table): Additions to level 2 are marked as shaded in the implementation table	
Maximum Data Link Frame Size (octets):  Transmitted 292 Received 292	Maximum Application Fragment Size (octets):  Transmitted 2048 Received 2048
Maximum Data Link Re-tries: Configurable, range from 0 to 255 with primary data link layer retransmission count, parameter F503V004	Maximum Application Layer Re-tries: Configurable, range from 0 to 255 with application layer retransmission count, parameter F503V007
Requires Data Link Layer Confirmation: Configurable, with confirmation type selector, parameter F503V008	
Requires Application Layer Confirmation: <input checked="" type="checkbox"/> Configurable with confirmation type selector when reporting Event Data (Slave devices only) <input checked="" type="checkbox"/> Always after response to reset request <input type="checkbox"/> Always when sending multi-fragment responses (Slave devices only) <input checked="" type="checkbox"/> Configurable, with confirmation type selector, parameter F503V009	
Timeouts while waiting for:	
Data Link Confirm	Configurable with primary data link layer timeout (parameter F503V003), not relevant when no ACK
Complete Appl. Fragment	No, multi-fragment application frames not supported
Application Confirm	Configurable with application layer timeout (parameter F503V006)
Complete Appl. Response	No, not relevant in slave

Sends/Executes Control Operations:

WRITE Binary Outputs	<input checked="" type="checkbox"/> Never
SELECT/OPERATE	<input checked="" type="checkbox"/> Always
DIRECT OPERATE	<input checked="" type="checkbox"/> Always
DIRECT OPERATE - NO	<input checked="" type="checkbox"/> Always
Count	Always 1
Code	1, 2 or 3
Trip/Close	1,2 according to direction
Pulse On	Ignored
Queue	Always 0
Clear Queue	0 or 1

**FILL OUT THE FOLLOWING ITEMS FOR SLAVE DEVICES ONLY:**

<p>Reports Binary Input Change Events when no specific variation requested:</p> <p><input type="checkbox"/> Never</p> <p><input type="checkbox"/> Only time-tagged</p> <p><input type="checkbox"/> Only non-time-tagged</p> <p><input checked="" type="checkbox"/> Configurable to send both, one or the other (parameter F503V011)</p>	<p>Reports time-tagged Binary Input Change Events when no specific variation requested:</p> <p><input type="checkbox"/> Never</p> <p><input type="checkbox"/> Binary Input Change With Time</p> <p><input type="checkbox"/> Binary Input Change With Relative Time</p> <p><input checked="" type="checkbox"/> Configurable (parameter F503V011)</p>
<p>Sends Unsolicited Responses:</p> <p><input type="checkbox"/> Never</p> <p><input checked="" type="checkbox"/> Configurable (parameter F503V024)</p> <p><input type="checkbox"/> Only certain objects</p> <p><input type="checkbox"/> Sometimes (attach explanation)</p> <p><input checked="" type="checkbox"/> ENABLE/DISABLE UNSOLICITED</p> <p>Function codes supported</p>	<p>Sends Static Data in Unsolicited Responses:</p> <p><input checked="" type="checkbox"/> Never</p> <p><input type="checkbox"/> When Device Restarts</p> <p><input type="checkbox"/> When Status Flags Change</p> <p>No other options are permitted.</p>
<p>Default Counter Object/Variation:</p> <p><input checked="" type="checkbox"/> No Counters Reported</p> <p><input type="checkbox"/> Configurable, default object and variation</p> <p><input type="checkbox"/> Default Object 20</p> <p><input type="checkbox"/> Default Variation 1</p> <p><input type="checkbox"/> Point-by-point list attached</p>	<p>Counters Roll Over at:</p> <p><input checked="" type="checkbox"/> No Counters Reported</p> <p><input type="checkbox"/> Configurable (attach explanation)</p> <p><input type="checkbox"/> 16 Bits</p> <p><input type="checkbox"/> 32 Bits, but roll-over bits not used</p> <p><input type="checkbox"/> Other Value _____</p> <p><input type="checkbox"/> Point-by-point list attached</p>
<p>Sends Multi-Fragment Responses: <input type="checkbox"/> Yes <input checked="" type="checkbox"/> No</p>	

### Supported function codes

CODE	FUNCTION	DESCRIPTION	Supported
<b>Transfer Function Codes</b>			
0	Confirm	Message fragment confirmation No response	Yes
1	Read	Request objects from outstation Respond with requested objects	Yes
2	Write	Store specified objects to outstation Respond with status of operation	Yes
<b>Control Function Codes</b>			
3	Select	Select output point of outstation Respond with echo of request and status of control point	Yes
4	Operate	Set output that has previously selected Respond with status of control point	Yes
5	Direct operate	Set output directly Respond with status of control point	Yes
6	Direct operate - no ack	Set output directly No response	Yes
<b>Freeze Function Codes</b>			
7	Immediate Freeze	Copy specified objects to freeze buffer Respond with status of operation	Yes
8	Immediate Freeze -no ack	Copy specified objects to freeze buffer No response	Yes
9	Freeze and Clear	Copy specified objects to freeze buffer and clear objects Respond with status of operation	Yes
10	Freeze and Clear -no ack	Copy specified objects to freeze buffer and clear objects No response	Yes
11	Freeze with time	Copy specified objects to freeze buffer at specified time Respond with status of operation	Yes
12	Freeze with time -no ack	Copy specified objects to freeze buffer at specified time No response	Yes
<b>Application Control Function Codes</b>			
13	Cold Restart	Perform desired reset sequence Respond with a time object	Yes
14	Warm Restart	Perform desired partial reset operation Respond with a time object	Yes
15	Initialise Data to Defaults	Initialise the specified data to default Respond with status of operation	No
16	Initialise Application	Ready the specified application to run Respond with status of operation	No
17	Start Application	Start the specified application to run Respond with status of operation	Yes
18	Stop Application	Stop the specified application to run Respond with status of operation	Yes

<b>Configuration Function Codes</b>			
19	Save configuration	Save configuration Respond with status of operation	No
20	Enable Unsolicited Messages	Enable Unsolicited Messages Respond with status of operation	Yes
21	Disable Unsolicited Messages	Disable Unsolicited Messages Respond with status of operation	Yes
22	Assign Class	Assign specified objects to a class Respond with status of operation	Yes
<b>Time Synchronization Function Codes</b>			
23	Delay Measurement	Perform propagation delay measurement	Yes
<b>Response Function Codes</b>			
0	Confirm	Message fragment confirmation	Yes
129	Response	Response to request message	Yes
130	Unsolicited Message	Spontaneous message without request	Yes

Note: REX 521 does not have Freeze Counters, even though the Freeze functions (7...12) are supported.

Note: When Multiple Object requests are used, the application layer timeout of the master device should be long enough for the relay to perform all the requested operations.



**Protection Terminals and Relay**  
**DNP 3.0 Communication Protocol**  
 Technical Description

**Supported objects:**

OBJECT			REQUEST (slave must parse)		RESPONSE (master must parse)	
Obj	Var	Description	Func Codes (dec)	Qual Codes (hex)	Func Codes (dec)	Qual Codes (hex)
1	0	Binary Input - All Variations	1, 22	all except 0B (and 06 with function 22)	129	00, 01
1	1	Binary Input	1, 22	all except 0B (and 06 with function 22)	129	00, 01 when all points were requested otherwise the same as in request
1	2	Binary Input with Status	1, 22	all except 0B (and 06 with function 22)	129	00, 01 when all points were requested otherwise the same as in request
2	0	Binary Input Change - All Variations	1	06, 07, 08	129, 130	17, 28
2	1	Binary Input Change without Time	1	06, 07, 08	129, 130	17, 28
2	2	Binary Input Change with Time	1	06, 07, 08	129, 130	17, 28
2	3	Binary Input Change with Relative Time	1	06, 07, 08	129, 130	17, 28
10	0	Binary Output - All Variations	1	all except 0B and 06	129, 130	00, 01
10	1	Binary Output	1	all except 0B	129	00, 01 when all points were requested otherwise the same as in request
10	2	Binary Output with Status	1	all except 0B	129	00, 01 when all points were requested otherwise the same as in request
12	0	Control Block - All Variations				
12	1	Control Relay Output Block	3, 4, 5, 6	17, 28	129	
12	2	Pattern Control Block				
12	3	Pattern Mask				
20	0	Binary Counter - All Variations				
20	1	32-Bit Binary Counter				
20	2	16-Bit Binary Counter				
20	3	32-Bit Delta Counter				
20	4	16-Bit Delta Counter				
20	5	32-Bit Binary Counter without Flag				
20	6	16-Bit Binary Counter without Flag				
20	7	32-Bit Delta Counter without Flag				
20	8	16-Bit Delta Counter without Flag				

OBJECT			REQUEST (slave must parse)		RESPONSE (master must parse)	
Obj	Var	Description	Func Codes (dec)	Qual Codes (hex)	Func Codes (dec)	Qual Codes (hex)
21	0	Frozen Counter - All Variations				
21	1	32-Bit Frozen Counter				
21	2	16-Bit Frozen Counter				
21	3	32-Bit Frozen Delta Counter				
21	4	16-Bit Frozen Delta Counter				
21	5	32-Bit Frozen Counter with Time of Freeze				
21	6	16-Bit Frozen Counter with Time of Freeze				
21	7	32-Bit Frozen Delta Counter with Time of Freeze				
21	8	16-Bit Frozen Delta Counter with Time of Freeze				
21	9	32-Bit Frozen Counter without Flag				
21	10	16-Bit Frozen Counter without Flag				
21	11	32-Bit Frozen Delta Counter without Flag				
21	12	16-Bit Frozen Delta Counter without Flag				
22	0	Counter Change Event - All Variations	1	06, 07, 08	129,130	17, 28
22	1	32-Bit Counter Change Event without Time	1	06, 07, 08	129,130	17, 28
22	2	16-Bit Counter Change Event without Time	1	06, 07, 08	129,130	17, 28
22	3	32-Bit Delta Counter Change Event without Time				
22	4	16-Bit Delta Counter Change Event without Time				
22	5	32-Bit Counter Change Event with Time				
22	6	16-Bit Counter Change Event with Time				
22	7	32-Bit Delta Counter Change Event with Time				
22	8	16-Bit Delta Counter Change Event with Time				
23	0	Frozen Counter Event - All Variations				
23	1	32-Bit Frozen Counter Event without Time				
23	2	16-Bit Frozen Counter Event without Time				
23	3	32-Bit Frozen Delta Counter Event without Time				
23	4	16-Bit Frozen Delta Counter Event without Time				
23	5	32-Bit Frozen Counter Event with Time				

**Protection Terminals and Relay**  
**DNP 3.0 Communication Protocol**  
 Technical Description

OBJECT			REQUEST (slave must parse)		RESPONSE (master must parse)	
Obj	Var	Description	Func Codes (dec)	Qual Codes (hex)	Func Codes (dec)	Qual Codes (hex)
23	6	16-Bit Frozen Counter Event with Time				
23	7	32-Bit Frozen Delta Counter Event with Time				
23	8	16-Bit Frozen Delta Counter Event with Time				
30	0	Analog Input - All Variations	1, 22	all except 0B (and 06 with function 22)	129	00, 01
30	1	32-Bit Analog Input	1, 22	all except 0B (and 06 with function 22)	129	00, 01 when all points were requested otherwise the same as in request
30	2	16-Bit Analog Input	1, 22	all except 0B (and 06 with function 22)	129	00, 01 when all points were requested otherwise the same as in request
30	3	32-Bit Analog Input without Flag				
30	4	16-Bit Analog Input without Flag				
31	0	Frozen Analog Input - All Variations				
31	1	32-Bit Frozen Analog Input				
31	2	16-Bit Frozen Analog Input				
31	3	32-Bit Frozen Analog Input with Time of Freeze				
31	4	16-Bit Frozen Analog Input with Time of Freeze				
31	5	32-Bit Frozen Analog Input without Flag				
31	6	16-Bit Frozen Analog Input without Flag				
32	0	Analog Change Event - All Variations	1	06, 07, 08	129, 130	17, 28
32	1	32-Bit Analog Change Event without Time	1	06, 07, 08	129, 130	17, 28
32	2	16-Bit Analog Change Event without Time	1	06, 07, 08	129, 130	17, 28
32	3	32-Bit Analog Change Event with Time				
32	4	16-Bit Analog Change Event with Time				
33	0	Frozen Analog Event - All Variations				
33	1	32-Bit Frozen Analog Event without Time				
33	2	16-Bit Frozen Analog Event without Time				
33	3	32-Bit Frozen Analog Event with Time				

OBJECT			REQUEST (slave must parse)		RESPONSE (master must parse)	
Obj	Var	Description	Func Codes (dec)	Qual Codes (hex)	Func Codes (dec)	Qual Codes (hex)
33	4	16-Bit Frozen Analog Event with Time				
40	0	Analog Output Status - All Variations	1	all except 0B	129	00, 01
40	1	32-Bit Analog Output Status	1	all except 0B	129	00, 01 when all points were requested otherwise the same as in request
40	2	16-Bit Analog Output Status	1	all except 0B	129	00, 01 when all points were requested otherwise the same as in request
41	0	Analog Output Block - All Variations				
41	1	32-Bit Analog Output Block	3, 4, 5, 6	17, 28	129	
41	2	16-Bit Analog Output Block	3, 4, 5, 6	17, 28	129	
50	0	Time and Date - All Variations	1	all except 0B and 06	129	same as in request
50	1	Time and Date	1,2	all except 0B and 06	129	same as in request
50	2	Time and Date with Interval				
51	0	Time and Date CTO - All Variations				
51	1	Time and Date CTO <sup>1)</sup>	-	-	-	Sent only as part of message with events
51	2	Unsynchronized Time and Date CTO				Sent only as part of message with events
52	0	Time Delay - All Variations				
52	1	Time Delay Coarse			129	07
52	2	Time Delay Fine			129	07
60	0	Not defined				
60	1	Class 0 Data	1	06	129	00, 01
60	2	Class 1 Data	1, 20, 21	06 (06, 07, 08 with function 1)	129, 130	17, 28
60	3	Class 2 Data	1, 20, 21	06 (06, 07, 08 with function 1)	129, 130	17, 28
60	4	Class 3 Data	1, 20, 21	06 (06, 07, 08 with function 1)	129, 130	17, 28
70	1	File Identifier				
80	1	Internal Indications	2 on point 4 and 7	all except 0B and 06	129	-
81	1	Storage Object				
82	1	Device Profile				
83	1	Private Registration Object				
83	2	Private Registration Object Descriptor				
90	1	Application Identifier	17, 18	06	129	-
100	1	Short Floating Point				

**Protection Terminals and Relay**  
**DNP 3.0 Communication Protocol**  
 Technical Description

**REF 54\_**  
**RET 54\_**  
**REX 521**

OBJECT			REQUEST (slave must parse)		RESPONSE (master must parse)	
Obj	Var	Description	Func Codes (dec)	Qual Codes (hex)	Func Codes (dec)	Qual Codes (hex)
100	2	Long Floating Point				
100	3	Extended Floating Point				
101	1	Small Packed Binary-Coded Decimal				
101	2	Medium Packed Binary-Coded Decimal				
101	3	Large Packed Binary-Coded Decimal				
		No Object	13, 14			
		No Object	23			

1) If the "Time synchronization mode" parameter, F503V025, is set to Periodic or Startup, CTO will be unsynchronized until the first time synchronization. If the parameter is set to Never, CTO is always synchronized.



## 6. Appendix C: Examples of mapping application data into the DNP 3.0 protocol

These examples describe the relation between the relay application and DNP 3.0 protocol mapping in the relay. Not all information presented here is available during protocol mapping process with the PMT. For PMT and protocol mapping process refer to the PMT Operator's Manual.

**Table 6.-1 Glossary for the examples.**

Heading	Explanation
Row	Row number
Name	Signal name
DB Name / Event	Name of the parameter in PMT / Event code
Data type	DNP 3.0 data type, See "DNP 3.0 data type codes" on page 39.
Object	DNP 3.0 object type
Point	DB address
Class	DNP 3.0 class, See "DNP 3.0 classes (default assignment)" on page 40.
Variations	Variations supported by variable
Functions	Functions supported by variable
UR	Unsolicited Response

**Table 6.-2 DNP 3.0 data type codes**

Name	Code	Data type
BOOL	0	Boolean value - 0 or 1
DPBOOL	1	Double point value: 00 - intermediate, 01 -closed (earthed), 10 - opened (freed), 11 - faulty
SINT	2	16-bit signed integer
INT	3	16-bit signed integer
DINT	4	32-bit signed integer
USINT	5	16-bit unsigned integer
UINT	6	16-bit unsigned integer
UDINT	7	32-bit unsigned integer
REAL	8	32-bit floating point
TIME	9	32-bit unsigned integer containing number of milliseconds
TOD	10	32-bit unsigned integer containing time of the day since midnight in 100us units
DATE	11	32-bit unsigned integer containing number of days since 01-01-1980
CLOCK	12	Full time of DNP 3.0 type used for time synchronization (function)
STRING	13	String value
BYTE	15	8-bit unsigned integer
WORD	16	16-bit unsigned integer
DWORD	17	32-bit unsigned integer
Event		Event

**Table 6.-3 DNP 3.0 classes (default assignment)**

Class	Assignment
0 (static data)	The set of static data important from the process point of view is assigned to class 0. This solution makes it possible to read all these values using a single request from the master station. This request is called a General Interrogation or GI. (A GI updates the master station's database after communications trouble, power loss, etc.)
1 (event data)	All points of type <i>Binary input change event</i> are assigned to this class. By default, unsolicited reporting of these points is enabled.
2 (event data)	All points of type <i>Analog input change event</i> are assigned to this class. By default, unsolicited reporting of these points is enabled.
3 (event data)	All points of type <i>Counter change event</i> are assigned to this class. By default, unsolicited reporting of these points is enabled.

### 6.1. COIND1, switch state mapping

The function block COIND1 is used to report changes in the state of a monitored switch.

Two kinds of information is available from the COIND1 block:

- current state of the switch - database item F127V001,
- events indicating changes of the switch position: E0, E1 and E2

In the DNP 3.0 protocol, this information is mapped as:

- binary input with status point - for the current state of the switch,
- related binary input change points - for events.

The switch can be in one of four states: open, closed, intermediate or faulty. State information is encoded on three bits.

Three consecutive binary inputs are used to transfer the switch state. The following encoding of the switch state is used in the DNP 3.0 protocol:

Binary Input in DNP 3.0	Switch state = Open	Switch state = Closed	Switch state = Intermediate	Switch state = Faulty
Is Open	1	0	0	0
Is Closed	0	1	0	0
Is Faulty	0	0	0	1

Row	Name	DB name / Event	Data type	Object	Point	Class	Variations	Functions	UR
1	Is Closed	F127V001	Boolean	1	0	0	1, 2	1, 20, 21, 22	0
2	State Closed Event	127E1	Event	2	0	1	1, 2, 3	1	1
3	Is Open	F127V001	Boolean	1	1	0	1, 2	1, 20, 21, 22	0
4	State Open Event	127E0	Event	2	1	1	1, 2, 3	1	1
5	Is Faulty	F127V001	Boolean	1	2	0	1, 2	1, 20, 21, 22	0
6	State Faulty Event	127E2	Event	2	2	1	1, 2, 3	1, 20, 21, 22	1

Row 1, Row 3 and Row 5 define the static binary input points.



Row 2, Row 4 and Row 6 define the related events. The event code given in the DB Name/ Event column names the internal event in the relay that is used to update the value of the static binary input point. This internal event generates an event with value 1 to DNP 3.0. Other events that are not listed in this table are related to this point and generate an event with value 0 to DNP 3.0.

## 6.2. NOC3Low, state of protection signal

The function block NOC3Low provides the START signal for the non-directional current overload function. This information is mapped as binary input. There are two events associated with this point. Those events will be reported as binary input change event.

Row	Name	DB name	Data type	Object	Point	Class	Variations	Functions	UR
1	Output START	F031O001	Boolean	1	0	0	1, 2	1, 20, 21, 22	0
2	START deactivated / activated	31E0 / 31E1	Event	2	0	1	1, 2, 3	1	1

## 6.3. COCB1, control command mapping

The function block COCB1 is used to control and monitor the position of a circuit breaker. Two types of control operations are available:

- one-step direct command - F120V004 and F120V005 for direct open and direct close,
- two-step select/execute commands - F120V006 and F120V007 to select open and close, F120V011 to execute the selected operation and F120V010 to cancel the selection.

Feedback information about the current state of the breaker is available from object F120V001.

In the DNP 3.0 protocol these data items are mapped as:

- control relay output block - for control commands,
- related binary output with status - for the current state of the breaker.

The following encoding of the breaker state is used in the DNP 3.0 protocol:

- open - the input is on-line and has the value 1,
- closed - the input is on-line and has the value 0,
- intermediate - the input is off-line and has the value 0,
- faulty - the input is off-line and has the value 1.

The DNP 3.0 protocol provides close and trip commands (trip command corresponds to open).

Row	Name	DB name	Data type	Object	Point	Class	Variations	Functions	UR
1	Direct open	F120V004	Boolean	12	0	4	1	3, 4, 5, 6	0
2	Direct close	F120V005	Boolean	12	0	4	1	3, 4, 5, 6	0
3	Open select	F120V006	Boolean	12	0	4	1	3, 4, 5, 6	0
4	Close select	F120V007	Boolean	12	0	4	1	3, 4, 5, 6	0
5	Execute	F120V010	Boolean	12	0	4	1	3, 4, 5, 6	0
6	Cancel	F120V011	Boolean	12	0	4	1	3, 4, 5, 6	0

#### 6.4. CMBWEAR1, control command on software binary point

Condition monitoring function CMBWEAR1 provides means to acknowledge wear alarm. This point is only writable in the relay application. However, for compatibility with the DNP 3.0 specification it is mapped as control relay output block (for acknowledging an alarm) and binary output status (for reading).

Row	Name	DB name	Data type	Object	Point	Class	Variations	Functions	UR
1	Alarm ACK	F187V099	Boolean	10	0	0	1, 2	1, 20, 21, 22	0
2	Alarm ACK	F187V099	Boolean	12	0	4	1	3, 4, 5, 6	0

#### 6.5. BIO1, binary input change counter (REF 54\_ and RET 54\_)

BIO1 card provides a counter of binary input change. This information is mapped as binary counter. Event informing of the counter value change is also provided. This information is mapped as binary counter change event.

Row	Name	DB name	Data type	Object	Point	Class	Variations	Functions	UR
1	Input 9 counter	F015I041	DINT	20	0	0	1, 2	1, 7, 8, 9, 10, 11, 12, 20, 21, 22	0
2	Counter 1 updated	F015E060	Event	22	0	3	1, 2	1	0

#### 6.6. MECU1A, mapping of analog input with limit and delta supervision

The MECU1A function block provides neutral current measurement and two methods of supervising this signal - limit (high warning and high alarm) and threshold (delta change).

Two kinds of information are available from the MECU1A block:

- neutral current value - database item F201I001,
- events that indicate crossing of the limit levels (E0, E1, E2 and E3) or the threshold level (E5).

In the DNP 3.0 protocol these items are mapped as:

- analog input point - for static value of neutral current,
- related analog input change without time points - for events.

Since the analog input change type does not identify the cause of an event (which level has been crossed), the events E0, E1, E2 and E3 are mapped as binary input change with time points (separate for warning and for alarm).

Row	Name	DB name	Data type	Object	Point	Class	Variations	Functions	UR
1	Io	F2011001	REAL	30	0	0	1,2	1, 20, 21, 22	0
2	Io HW reset / activated	201E0 / 201E1	Event	32	0	2	1,2	1	1
3	Io HA reset / activated	201E2 / 201E3	Event	32	0	2	1,2	1	1
4	Io delta	201E5	Event	32	0	2	1,2	1	1
5	Io HW reset / activated	201E0 / 201E1	Event	1	0	0	1,2	1, 20, 21, 22	0
6	Io HW reset / activated	201E0 / 201E1	Event	2	0	1	1, 2, 3	1	1
7	Io HA reset / activated	201E2 / 201E3	Event	1	1	0	1,2	1, 20, 21, 22	0
8	Io HA reset / activated	201E2 / 201E3	Event	2	1	1	1, 2, 3	1	1

## 6.7.

### **CMBWEAR1, electric wear measurement**

The CMBWEAR1 function block provides electric wear measurement of the breaker. This information can be read or written (i.e. cleared after changing the breaker in the installation). The information is mapped as two DNP 3.0 points associated with each other (by point number): analog output status and analog output block.

Row	Name	DB name	Data type	Object	Point	Class	Variations	Functions	UR
1	Wear IL1	F187V001	REAL	10	0	0	1,2	1	0
2	Wear IL1	F187V001	REAL	12	0	4	1, 2	3, 4, 5, 6	0

## 6.8.

### **DNP\_3, device clock**

The real-time clock of the relay is mapped as time point in DNP 3.0.

Row	Name	DB name	Data type	Object	Point	Class	Variations	Functions	UR
1	Device internal clock	DEVCLK	TIME	50	0	4	1	1, 2	0



**ABB Oy**

Distribution Automation

P.O. Box 699

FI-65101 Vaasa

FINLAND

Tel. +358 10 22 11

Fax. +358 10 224 1094

[www.abb.com/substationautomation](http://www.abb.com/substationautomation)