

Case note

ACS 6000 multidrive provides speed control for wind turbine test benches



The power train test bench in CENER's wind test laboratory is controlled by ABB's ACS 6000 variable speed drive.

Spain's National Renewable Energy Center (CENER), has one of the world's most modern wind turbine test laboratories.

ABB's ACS 6000 multidrive, with a total rated power of 36 MVA, controls the power train, generator and nacelle test benches in the power train test laboratory where wind turbines and wind turbine components are exposed to highly accelerated tests.

Highlights

One ACS 6000 multidrive controls the motors of three test benches

ABB's AC 800PEC modular controller running the 800xA Control Builder is used to model different wind conditions

The ACS 6000 enables 50 Hz and 60 Hz wind turbine tests with the same testing infrastructure

Several tests of wind turbines and wind turbine components can be run simultaneously

CENER

The National Renewable Energy Center (CENER), located in Sangüesa (Navarre), Spain, is an internationally recognized technology center specializing in applied research, development and promotion of renewable energies.

The center provides services to and performs research work in wind energy, solar thermal energy, photovoltaic solar energy, biomass energy, bioclimatic architecture and renewable energy grid integration.

Wind turbine test laboratory

CENER has a cutting-edge technological infrastructure, with the most modern laboratories and facilities in Europe. Its Wind Turbine Test Laboratory (LEA) is the only infrastructure of this kind in the world.

LEA has six test centers, including a blade test laboratory, a power train test laboratory to test multi-megawatt wind turbines and a composite materials and processes laboratory. It also has a 30 MW experimental wind farm where field tests are conducted.

Power train test laboratory

LEA's power train test laboratory features a series of test benches including a power train test bench, a generator and converter test bench, a nacelle test bench and a nacelle assembly bank. The facilities are used to conduct highly accelerated life tests (HALT) and functional tests on mechanical and electrical equipment.

Challenge

In the power train test laboratory, wind turbines are exposed to demanding HALTs. The tests, which run 24 hours each day for periods of up to nine months, simulate the equipment's 25 year life expectancy.

The test laboratory provides the infrastructure to perform complete 50 Hz and 60 Hz wind turbine tests.

Solution

ABB supplied the following equipment to the test laboratory: one 8 MVA and two 10 MVA transformers, one 6 MW and two 8 MW induction motors and one 36 MVA ACS 6000 variable speed multidrive including PLC control for simulating different wind conditions.

The ACS 6000 multidrive controls the three motors of the power train test bench, the nacelle test bench and the generator test bench. It has one Active Rectifier Unit (ARU) rated at 9 MVA and four Inverter Units (INUs) rated at 9 MVA each.

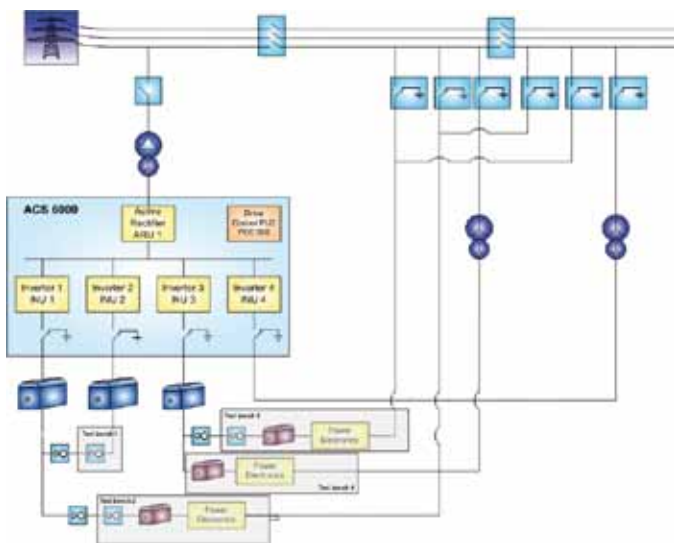

Diagram showing the configurations of the test benches.

Power train test bench

A gearbox is one of the most sensitive parts of a wind turbine. Gearboxes and bearings on the low speed shaft are subjected to HALT in the power train test bench. In addition, functional and load tests are performed on brakes and brake pads of the high speed shaft and the mechanical parts of the wind turbine generator drive train. To simulate the equipments' lifespan, INU 1 of the ACS 6000 drives the motor of the test bench while INU 2 acts as a load. Thus, the stress on the gearbox subjected to test is increased by a multiple, simulating 25 years of operation in only nine months.

Nacelle test bench

The nacelle test bench performs functional tests of the complete nacelle against a power electronics grid load.

Due to the ACS 6000 multidrive configuration, CENER has two identical nacelle test set ups and is able to run two tests of the complete nacelle, including gearbox, generator and power electronics, simultaneously.

INU 1 of the ACS 6000 controls the motor that runs one nacelle test bench, while INU 3 controls the motor that runs the other nacelle test bench.

CENER is also able to perform 50 Hz and 60 Hz wind turbine tests. INU 4 of the ACS 6000 acts as network simulator which generates the required frequency to the power electronics of the test equipment and absorbs the electrical energy back into the multidrive.

Generator test bench

The generator test bench performs functional tests, overspeed tests, heat load tests, acceleration/deceleration (winding/PM fatigue test) and HALT on the generator and the power electronics and simulates electrical transient, voltage dips and transient surges.

The motor of the generator test bench is controlled by INU 3 of the ACS 6000.



ABB motor at one of CENER's test benches

ACS 6000 for demanding applications

The ACS 6000 is a modular, medium voltage drive designed for the most demanding single and multi-drive applications. It is available with several inverter modules (3, 5, 7, 9 and 11 MVA) for induction and synchronous motors. The optimum configuration for every specific application can be reached by combining the standard modules up to a total power of 36 MVA.

Several motors can be linked to an ACS 6000 via a common DC bus, enabling multidrive operation with only one DC bus supply rectifier. The common DC bus system allows motoring and generating power flow between the inverters through the DC bus.

At the heart of the ACS 6000 is a motor control platform, Direct Torque Control (DTC). DTC results in the highest torque and speed performance ever achieved with variable speed drives, making it possible to control the full torque within a few milliseconds, eliminating possible resonance problems and reducing the impact of load shocks. The high static and dynamic accuracy guarantees that control of the drive is immediate and smooth under all conditions, and in full four-quadrant operation.

ACS 6000 key data

Inverter type	Three-level Voltage Source Inverter (VSI)
Converter cooling	Water cooling
Power range	3 - 27 MW (water cooling)
Output voltage	3.0 - 3.3 kV (optional: 2.3 kV)
Maximum output frequency	75 Hz (higher on request)
Converter efficiency	Typically > 98.5% (incl. all auxiliaries)
Type of motor	Induction, synchronous and/or permanent magnet motor
Special feature	Available as single or multidrive



ACS 6000 multidrive, with a total rated power of 36 MVA, controlling the test benches at CENER.

For more information please contact:

ABB Inc.

Medium Voltage Drives

16250 W. Glendale Drive

New Berlin, WI 53151

Tel: 800-752-0696

Fax: 262-785-3322

E-Mail: mv.drives.sales@us.abb.com

www.abb.com/drives

www.cener.com