

Protection Relay REX 521

Technical Reference Manual, General



Contents

1. About this manual	9
1.1. This manual	9
1.2. Use of symbols	9
1.3. Related documents	10
1.4. Document revisions	10
2. Safety information	11
3. Introduction	13
3.1. General	13
3.2. Application	14
3.3. Hardware versions	16
4. Requirements	17
5. Technical description	19
5.1. Functional description	19
5.1.1. Parametrization	19
5.1.1.1. Local parametrization	19
5.1.1.2. External parametrization	19
5.1.1.3. Relay Setting Tool view	20
5.1.1.4. Graphical I/O Setting Tool	20
5.1.1.5. Factory settings	21
5.1.2. Non-volatile memory	22
5.1.3. Real-time clock	22
5.1.4. Auxiliary voltage	22
5.1.4.1. Power supply versions	23
5.1.4.2. Low auxiliary voltage indication	23
5.1.5. Overtemperature indication	23
5.1.6. Analog channels	24
5.1.6.1. Scaling the rated values of the protected unit for analog channels	24
5.1.6.2. Technical data of the measuring devices	25
5.1.6.3. Calculated analog channels	27
5.1.6.4. Select Io	27
5.1.6.5. Rated frequency	27
5.1.7. Digital inputs	27
5.1.7.1. Filtering of digital inputs	27
5.1.7.2. Inversion of digital inputs	28
5.1.8. Outputs	28
5.1.8.1. High-speed power output (HSPO)	28
5.1.8.2. Single-pole power outputs (PO)	29
5.1.8.3. Signalling outputs (SO)	30

5.1.9.	Testing inputs and outputs	30
5.1.10.	Trip-circuit supervision	31
5.1.11.	Self-supervision	33
5.1.11.1.	Fault indication	34
5.1.11.2.	Fault indication texts	35
5.1.12.	Serial communication	36
5.1.12.1.	Optical communication port on the rear panel	36
5.1.12.2.	Isolated RS-485 connection on the rear panel	37
5.1.12.3.	Front panel optical connection for a PC	37
5.1.12.4.	The service pin located on the rear panel	37
5.1.12.5.	SPA bus	37
5.1.12.6.	LON	39
5.1.12.7.	IEC 60870-5-103 bus	40
5.1.12.8.	Modbus	41
5.1.12.9.	DNP 3.0 Bus	42
5.1.12.10.	IEC 61850 communication by using SPA-ZC 402	43
5.1.12.11.	Profibus-DPV1 communication by using SPA-ZC 302	43
5.1.13.	Time synchronization	44
5.1.14.	Display panel (HMI)	45
5.1.15.	Indication LEDs	45
5.1.16.	Alarm LEDs	45
5.1.16.1.	Special features of alarm LEDs	46
5.1.16.2.	Writing signal names on alarm LED label	46
5.2.	Design description	48
5.2.1.	Technical data	48
5.2.2.	Terminal diagram of REX 521: Basic	52
5.2.3.	Terminal diagram of REX 521: Medium	53
5.2.4.	Terminal diagram of REX 521: High (excluding H08 and H09)	54
5.2.4.1.	Terminal diagram of H08 and H09 configurations	55
5.2.5.	Terminal diagram of REX 521: Sensor	56
5.2.6.	Terminal connections	57
6.	Service	59
7.	Ordering information	61

Technical Reference Manual, General

8. Revision history of REX 521	63
8.1. Revision identification	63
8.2. Changes and additions to earlier released revision E	63
8.3. Configuration, setting, and SA system tools	63
9. Appendix A: IEC 60870-5-103 bus	65
9.1. Functions supported by REX 521	65
9.2. General principle of application data mapping	65
9.3. Principle of the protection functions mapping	66
9.4. Class 2 data	66
9.5. Default mappings	67
10. Appendix B: Parameters visible only in the relay	73
11. Appendix C: Parameters which cause reset	75
12. Appendix D: Parameters which require test mode	77
13. Abbreviations	79
14. Index	81

Copyrights

The information in this document is subject to change without notice and should not be construed as a commitment by ABB Oy. ABB Oy assumes no responsibility for any errors that may appear in this document.

In no event shall ABB Oy be liable for direct, indirect, special, incidental or consequential damages of any nature or kind arising from the use of this document, nor shall ABB Oy be liable for incidental or consequential damages arising from use of any software or hardware described in this document.

This document and parts thereof must not be reproduced or copied without written permission from ABB Oy, and the contents thereof must not be imparted to a third party nor used for any unauthorized purpose.

The software or hardware described in this document is furnished under a license and may be used, copied, or disclosed only in accordance with the terms of such license.

Copyright © 2006 ABB Oy
All rights reserved.

Trademarks

ABB is a registered trademark of ABB Group. All other brand or product names mentioned in this document may be trademarks or registered trademarks of their respective holders.

Guarantee

Please inquire about the terms of guarantee from your nearest ABB representative.

1. About this manual

1.1. This manual

This document provides a general description of the protection relay REX 521 Revision G. For more information about the earlier revisions, refer to section “Revision history of REX 521” on page 63.

For detailed information about the separate functions, see REX 521 Technical Reference Manual, Standard Configurations (see “Related documents” on page 10).

1.2. Use of symbols

This publication includes the following icons that point out safety-related conditions or other important information:



The electrical warning icon indicates the presence of a hazard which could result in electrical shock.



The caution icon indicates important information or warning related to the concept discussed in the text. It might indicate the presence of a hazard which could result in corruption of software or damage to equipment or property.



The information icon alerts the reader to relevant facts and conditions.

Although warning hazards are related to personal injury, it should be understood that operation of damaged equipment could, under certain operational conditions, result in degraded process performance leading to personal injury or death. Therefore, comply fully with all warning and caution notices.

1.3. Related documents

Manuals for REX 521

- Technical Reference Manual, Standard Configurations 1MRS751802-MUM
- Operator’s Manual 1MRS 751107-MUM
- Installation Manual 1MRS 750526-MUM
- Technical Descriptions of Functions (CD-ROM) 1MRS750889-MCD
- Modbus Remote Communication Protocol for REX 521, Technical Description 1MRS755017
- DNP 3.0 Remote Communication Protocol for REF 54_, RET 54_ and REX 521, Technical Description 1MRS755260

Parameter and event lists for REX 521

- Parameter List for REX 521 1MRS751999-RTI
- Event List for REX 521 1MRS752000-RTI
- General Parameters for REX 521 1MRS752156-RTI
- Interoperability List for REX 521 1MRS752157-RTI

Tool-specific manuals

- CAP505 Installation and Commissioning Manual 1MRS751901-MEN
- CAP505 User’s Guide 1MRS752292-MEN
- CAP505 Protocol Mapping Tool Operator’s Manual 1MRS755277
- Tools for Relays and Terminals, User’s Guide 1MRS752008-MUM
- CAP 501 Installation and Commissioning Manual 1MRS751899-MEN
- CAP 501 User’s Guide 1MRS751900-MUM

1.4. Document revisions

Version	Date	History
E	22.6.2004	Manual updated to include DNP 3.0
F	10.8.2004	Minor updates
G	23.2.2006	Layout updated FB updates IRF code 70, HMI error, added Standard configurations H09, H50, H51 added New HMI Selectable ANSI/IEC FB naming
H	29.9.2006	Small corrections to the standard configuration table
K	18.10.2010	Minor updates

2. Safety information



Dangerous voltages can occur on the connectors, even though the auxiliary voltage has been disconnected.

Non-observance can result in death, personal injury or substantial property damage.

Only a competent electrician is allowed to carry out the electrical installation.

National and local electrical safety regulations must always be followed.

The frame of the device has to be carefully earthed.



The device contains components which are sensitive to electrostatic discharge. Unnecessary touching of electronic components must therefore be avoided.

Breaking the sealing tape on the rear panel of the device will result in loss of warranty and proper operation will no longer be guaranteed.

3. Introduction

3.1. General

The protection relay REX 521 is designed for protection, control, measuring, and supervision in medium voltage networks. Typical applications include incoming and outgoing feeders as well as substation protection. The protection relay is provided with energizing inputs for conventional current and voltage transformers. Also a hardware version with inputs for current and voltage sensors is available.

The protection relay is based on a multiprocessor environment. The HMI¹ (Human-Machine Interface) including an LCD (Liquid Crystal Display) with different views makes the local use easy and informs the user via indication messages. Modern technology is applied both in hardware and software solutions.

The REX 521 is part of the substation automation concept for Distribution Automation and extends the functionality and flexibility of the concept further.



A051897

Fig. 3.1.-1 REX 521 protection relay

1. HMI is referred to as MMI (man-machine interface) in the relay and in the Relay Setting Tool.

3.2. Application

- The REX 521 is designed for protection of incoming and outgoing feeders in medium voltage distribution substations. Further, the relay can, for example, be applied to back-up protection of power transformers and back-up for high voltage line protection relays.

Table 3.2.-1 Standard configurations for REX 521

HW versions			Basic		Medium		High/Sensor										
Standard configurations			B01	B02	M01	M02	H01 ^a	H02	H03	H04	H05	H06	H07	H08 ^{bc}	H09 ^{bc}	H50 ^b	H51 ^b
IEC symbol	ANSI device number	FB name (CD-ROM)															
Protection																	
3I>	51-1	NOC3Low	x	x	x	x		x	x	x	x	x	x	x	x	x	x
3I>>	51-2	NOC3High	x	x	x	x		x	x	x	x	x	x	x	x	x	x
3I>>>	51-3	NOC3Inst	x	x	x	x	x		x	x	x	x	x	x	x	x	x
Io>	51N-1	NEF1Low	x	x						x ^d	x		x	x	x	x	x
Io>>	51N-2	NEF1High	x	x						x ^d	x		x	x	x	x	x
Io>>>	51N-3	NEF1Inst	x	x						x ^d	x		x	x			
Io>--> ^e	67N-1	DEF2Low			x	x	x	x	x	x			x			x	x
Io>>--> ^e	67N-2	DEF2High			x	x	x	x	x	x			x			x	x
Io>>>--> ^e	67N-3	DEF2Inst			x	x	x	x	x	x							
3I>-->	67-1	DOC6Low					x ^f	x ^f		x ^f						x ^f	
3I>>-->	67-2	DOC6High					x ^f	x ^f								x ^f	x ^f
3U>	59-1	OV3Low									x	x	x	x	x	x	x
3U>>	59-2	OV3High									x	x	x	x	x	x	
3U<	27-1	UV3Low									x	x	x	x	x	x	x
3U<<	27-2	UV3High									x	x	x	x	x	x	
3I2f>	68	Inrush3	x	x	x	x	x	x	x	x	x			x	x	x	
Iub>	46	CUB3Low	x	x	x	x	x	x	x	x							
3Ith>	49F	TOL3Cab	x	x	x	x	x	x	x	x							
O-->I	79	AR5Func		x		x	x	x	x	x					x	x	
Uo>	59N-1	ROV1Low									x	x		x	x	x	x
Uo>>	59N-2	ROV1High									x	x		x	x	x	
Uo>>>	59N-3	ROV1Inst									x	x		x	x		
f1	81-1	Freq1St1						x		x		x	x		x	x	x
f2	81-2	Freq1St2										x			x	x	x
SYNC1	25-1	SCVCSt1					x		x								
Is2t n<	48	MotStart											x				x
3I()	46R	PREV3											x				x
I2>	46-1	NPS3Low											x				x
I2>>	46-2	NPS3High											x				
3I<	37-1	NUC3St1											x				
FUSEF	60	FuseFail											x				x
3Ithdev>	49M/G/T	Tol3Dev									x		x	x			x
U1U2<>_1	47-1	PSV3St1											x			x	x

Table 3.2.-1 Standard configurations for REX 521 (Continued)

HW versions			Basic		Medium		High/Sensor										
Standard configurations			B01	B02	M01	M02	H01 ^a	H02	H03	H04	H05	H06	H07	H08 ^{bc}	H09 ^{bc}	H50 ^b	H51 ^b
IEC symbol	ANSI device number	FB name (CD-ROM)															
Control functions																	
I<->O CB1	COCB1	COCB1	x	x	x	x	x	x	x	x	x	x	x	x	x	x	x
I<->O IND1	COIND1	COIND1	x	x	x	x	x	x	x	x	x	x	x	x	x	x	x
I<->O IND2	COIND2	COIND2	x	x	x	x	x	x	x	x	x	x	x	x	x	x	x
I<->O IND3	COIND3	COIND3											x ^g				x ^g
I<->O POS	COLOCAT	COLOCAT	x	x	x	x	x	x	x	x	x	x	x	x	x	x	x
ALARM1-8	ALARM1-8	MMIALAR1-8	x	x	x	x	x	x	x	x	x	x	x	x	x	x	x
Measurement																	
3I	3I	MECU3A	x	x	x	x	x	x	x	x	x	x	x	x	x	x	x
Io	Io	MECU1A	x	x	x	x	x	x	x	x	x	x	x	x	x	x	x
Uo	Uo	MEVO1A			x	x	x	x	x	x	x	x	x	x	x	x	x
DREC	DREC	MEDREC	x	x	x	x	x	x	x	x	x	x	x	x	x	x	x
3U	3U	MEVO3A					x	x	x	x	x	x	x	x	x	x	x
3U_B	3U_B	MEVO3B												x	x		
f	f	MEFR1					x	x	x	x	x	x	x	x	x	x	x
PQE	PQE	MEPE7					x	x	x	x	x	x	x	x	x	x	x
AI1	AI1	MEAI1											x				x
Condition monitoring																	
CB wear1	CB wear1	CMBWEAR1	x	x	x	x	x	x	x	x	x	x	x	x	x	x	x
TCS1	TCS1	CMTCS1	x	x	x	x	x	x	x	x	x	x	x	x	x	x	x
MCS 3I	MCS 3I	CMCU3	x	x	x	x	x	x	x	x	x	x	x	x	x	x	x
MCS 3U	MCS 3U	CMVO3					x	x	x	x	x	x	x	x	x	x	x
TIME1	TIME1	CMTIME1											x				x
Power quality monitoring																	
PQ 3Inf	PQ 3Inf	PQCU3H	x	x	x	x	x	x	x	x	x	x	x	x	x	x	x
PQ 3Unf	PQ 3Unf	PQVO3H					x	x	x	x	x	x	x	x	x	x	x
Standard																	
SWGRP	SWGRP	SWGRP	x	x	x	x	x	x	x	x	x	x	x	x	x	x	x

- a. H01 available only as sensor version
- b. Not available as sensor version
- c. VTs are used to measure phase-to-earth voltages, calculated phase-to-phase voltages are shown by 3U_B
- d. Configured fixedly to the Io (1/5 A) channel or Ios if selected
- e. Can be used as Io>, Io>> and Io>>> or Uo>, Uo>> and Uo>>> function block with some limitations
- f. 3I>> and 3I>>> cannot be set to operate as 3I>, 3I>> or 3I>>>
- g. Motor status indication



Calculated Uo (Uos) is used in the Sensor versions of H01 and H03 configurations. Calculated Io (Ios) is available in H01-H05, H08, H09 and H50 configurations.

For more information, see REX 521 Technical Reference Manual, Standard Configurations (see “Related documents” on page 10).

3.3. Hardware versions

Table 3.3.-1 Hardware versions of REX 521

Relay type	REX 521			
Version name	Basic	Medium	High	Sensor
	REX521xBxxx	REX521xMxxx	REX521xHxxx	REX521xSxxx
Transformer modules (MIM)	1	1	1	1
Transformers				
• Current transformers 1/5 A	4	4	4	1
• Current transformers 0.2/1 A		1	1	1
• Voltage transformers 100 V		1	4	1
Sensor channels				
• Current sensor inputs				3
• Voltage sensor inputs				3
Main CPU modules	1	1	1	1
CPU_SP (SPA/ IEC/MODBUS plastic)				
CPU_SG (SPA/ IEC/MODBUS glass)				
CPU_LP (SPA/ IEC/ LON/MODBUS plastic)				
CPU_LG (SPA/ IEC/ LON/MODBUS glass)				
Power supply modules	1	1	1	1
PS_87H (Dltresh.=80 VDC)				
PS_87L (Dltresh.=18 VDC)				
Display module	1	1	1	1
6 x 16 character display				
Digital inputs	9			
High-speed power outputs	1			
Power outputs (PO)	3			
Signalling outputs (SO)	2			
IRF outputs	1			
Trip-circuit supervision (TCS)	1			

4. Requirements

If the environmental conditions differ from those specified in section “Technical data” on page 48, as to temperature and humidity, or if the environmental conditions around the protection relay contain chemically active gases or dust, the relay should be visually inspected in association with the secondary testing. The visual inspection should focus on:

- Signs of mechanical damage to the relay case and terminals.
- Signs of corrosion on terminals or on the case.
- For information about the maintenance of relays, refer to section “Service” on page 59.



Protection relays are measuring instruments and should be handled with care and protected against moisture and mechanical stress, especially during transport.

5. Technical description

5.1. Functional description

5.1.1. Parametrization

To ensure that a protection function block protects the feeder in the desired manner, the default values of parameters must be checked and set before taking the function block into use.

The parameters can be set either locally over the HMI or externally via the serial communication using Relay Setting Tool. See “Serial communication” on page 36.

5.1.1.1. Local parametrization

The parameter to be changed is entered by navigating in the menu structure. For detailed instructions, see Operator’s Manual (see “Related documents” on page 10).

5.1.1.2. External parametrization

The Relay Setting Tool and/or Graphical I/O Setting Tool is used for external parametrization of the protection relay. The parameters can be set by using a PC and downloaded to the protection relay over a communication port. The menu structure of the setting tool, including parametrization and settings views, is the same as the menu structure of the protection relay¹. The use of the tool is instructed in Tools for Relays and Terminals, User’s Guide (see “Related documents” on page 10).

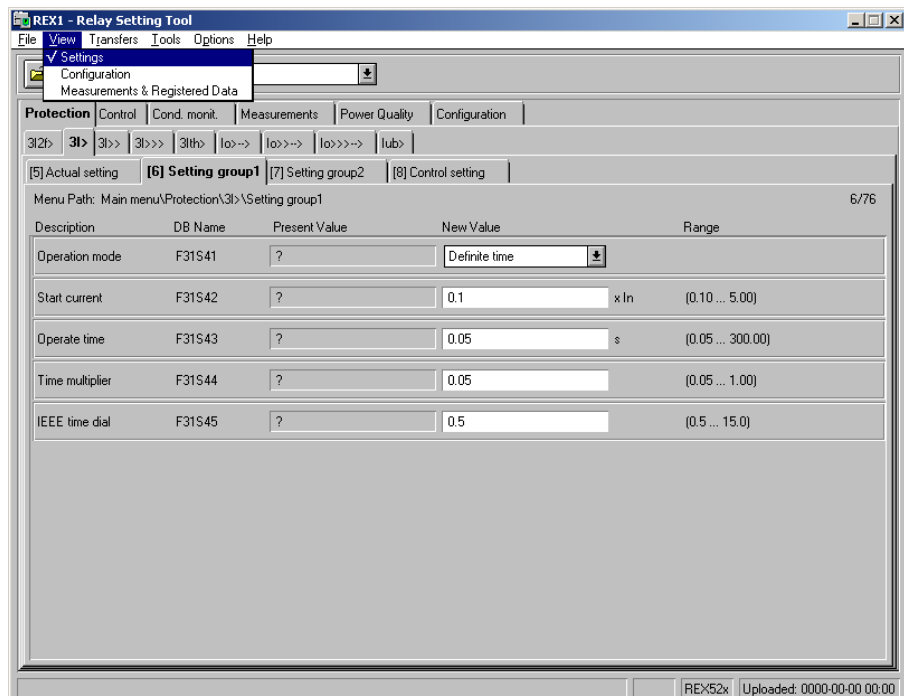

A051898

Fig. 5.1.1.2.-1 Main dialog box of the Relay Setting Tool

1. Some parameters are visible only in the relay, see the list on page 73.

5.1.1.3. Relay Setting Tool view

To improve usability, a REX 521 specific pull-down menu, **View**, with three views has been created to the Relay Setting Tool.

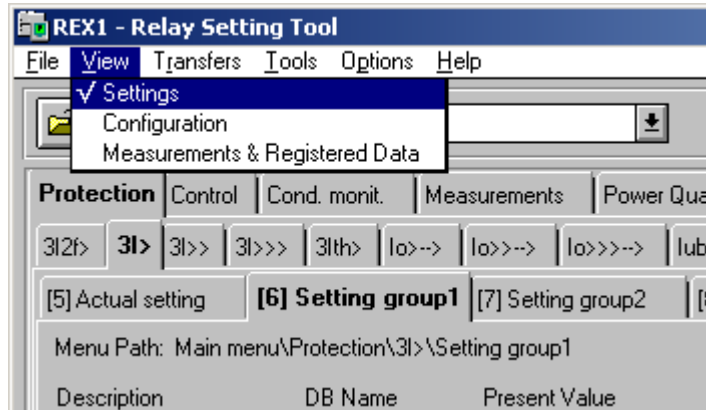

A051899

Fig. 5.1.1.3.-1 Relay Setting Tool views

The **Settings** view includes the parameters for setting of all the function blocks. The **Configuration** view includes signalling and hardware related settings. The parameters in the **Configuration** view are advised to be set during commissioning and service because some of the parameters cause resetting of the device. See “Appendix C: Parameters which cause reset” on page 75 for a list of these parameters. In that case the disturbance recorder DREC will be cleared. Measured values and registered data, for example current, digital input states, can be uploaded by means of the **Measurements & Registered Data** view.



When uploading or downloading parameters with Relay Setting Tool by using the option All, it covers only the parameters of the selected view (that is, **Settings**, **Configuration**, or **Measurements & Registered Data**).

5.1.1.4. Graphical I/O Setting Tool

To make the external relay parametrization even easier, a REX 521 specific Graphical I/O Setting Tool has been added to the Relay Setting Tool. The Graphical I/O Setting Tool offers a user-friendly environment for better visualization and makes it easier to get a complete overview of the settings.

The tool is used for setting input switchgroups, output switchgroups, and Alarm LED switchgroups. Using this tool is instructed in Tools for Relays and Terminals User's Guide (see “Related documents” on page 10).

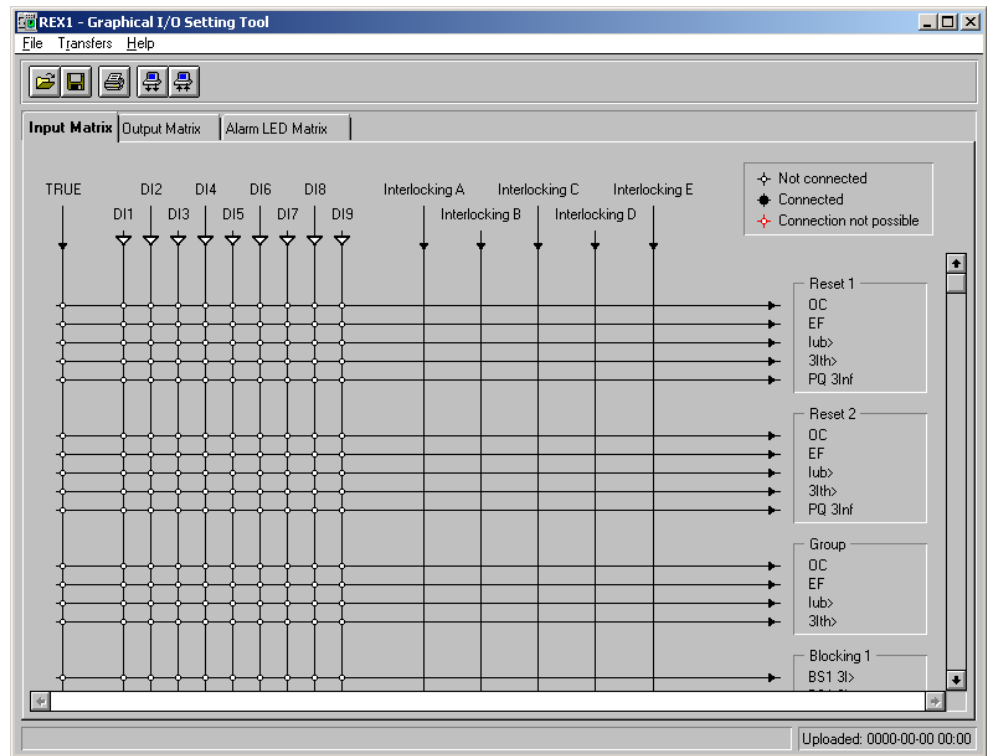

A0501900

Fig. 5.1.1.4.-1 Graphical I/O Setting Tool

5.1.1.5.

Factory settings

The factory settings for the relay can be restored by selecting “Activate” from HMI path Configuration\General\Software\Factory settings. After this, the relay will reset itself immediately and start with the factory-set parameter values.

When starting again, the relay display shows the text

:WARNING EEPROM -> FLASH

on the display. This means that the calibration parameters have been read from the MIM card and copied to the non-volatile memory of the CPU card. After ten seconds, the relay will reset itself again, and takes the correct calibration parameters into use.



The unnecessary restoring of factory settings should be avoided because all the parameter settings that are written earlier to the relay will be lost, that is, overwritten with the default values. During normal use this can cause a protection function to trip when the settings are suddenly changed.

5.1.2. **Non-volatile memory**

The protection relay is equipped with a non-volatile memory for preserving important data during auxiliary supply breaks. For example, when a setting value is changed, the new value is stored in the memory at the moment of sending it to the relay, without additional store commands. The memory does not need batteries, and a lifelong service is guaranteed.

Following data is stored in the non-volatile memory:

- Setting values
- Display state
- Lockout state
- Recorded values¹
- Last 50 events

When the relay is restarted, the LED indication and text displayed before the auxiliary supply break are restored on the display. More information about the alarm LEDs can be found in section “Alarm LEDs” on page 45.

Recorded values are stored from start, trip and other important events. After an auxiliary power break, time and date and fault currents for the three last events can be viewed by navigating to the “Recorded values” section of the function block that caused an indication.

The last 50 events that occurred before the auxiliary power supply break can be viewed in the HMI event buffer. Time and date for the events are also restored.

5.1.3. **Real-time clock**

The real-time clock (RTC) is used for time stamping of events. It is also running during auxiliary power breaks. When the supply is re-established, the relay sets the right time and new events are stamped accordingly.

The protection relay is provided with a 1-week capacitor back-up protection² that enables the internal clock to keep time in case of an auxiliary power failure.

5.1.4. **Auxiliary voltage**

For its operation, the protection relay requires a secured auxiliary voltage supply. The protection relay’s internal power supply module forms the voltages required by the protection relay electronics. The power supply module is a galvanically isolated (flyback-type) DC/DC converter. A green LED indicator on the front panel is lit when the power supply module is in operation.

-
1. Because the storing of the recorded values is a background task, it might be affected by a sudden auxiliary power failure.
 2. Capacitor ageing may decrease the back-up time.

5.1.4.1. Power supply versions

There are two basic versions of power supply modules available for REX 521 protection relays: type PS_87H and type PS_87L.

The input voltage range of the power supply module is marked on the front panel of the REX 521 unit. The power supply version is specified by a letter in the order number of the protection relay (refer to section “Ordering information” on page 61).

The voltage range of the digital inputs is tied to the selected power supply. If a power supply version with the higher rated input voltage is selected, the protection relays will be delivered with digital inputs that also have the higher rated input voltage. The digital input, DI9, on the CPU module has also lower rated input voltage.

The auxiliary voltages of power supply modules and the corresponding rated input voltages of digital inputs are:

Power supply module	Rated input voltage of power supply	Rated input voltage of digital inputs
PS_87H	110/120/220/240 V AC or 110/125/220 V DC	DI1...DI8: 110/125/220 V DC DI9: 24/48/60/110/125/220 V DC
PS_87L	24/48/60 V DC	DI1...DI9: 24/48/60/110/125/220 V DC

For further technical data of the power supply, see Table 5.2.1-2 on page 48.

5.1.4.2. Low auxiliary voltage indication

The relay is provided with a low auxiliary voltage indication feature. The power supply module issues an internal alarm signal when a drop in the power supply voltage is detected. The alarm signal is activated if the power supply voltage falls about 10% below the lowest rated DC input voltage of the power supply module, see the following table:

Rated input voltage	Low indication level
PS_87H	
• Rated input voltage 110/125/ 220 V DC	99 V DC
• Rated input voltage 110/120/220/ 240 V AC	88 V AC
PS_87L	
• Rated input voltage 24/48/60 V DC	21.6 V DC

The indication of a low auxiliary voltage (ACFail) can be seen as an event via serial communication.

5.1.5. Overtemperature indication

The REX protection relay includes an internal temperature supervision function. The CPU module issues an internal alarm signal when overtemperature has been detected inside the relay enclosure. The alarm signal will be activated once the temperature inside the relay enclosure increases approximately to +78°C. The overtemperature indication can be seen on the HMI or as an event via serial communication. The relay will go to the IRF (internal relay fault) state. See Table 5.1.11.2-1, “Fault indications,” on page 35.

5.1.6. Analog channels

The protection relay measures the analog signals needed for protection, measuring, etc. via galvanically separated matching transformers. In addition, current sensors (Rogowski coil) and voltage dividers developed by ABB can be used with REX 521.

The different versions of REX 521 are provided with the following matching transformers and sensor inputs:

Version	Matching transformers	Sensor inputs
Basic	CT1, CT2, CT3, CT4	-
Medium	CT1, CT2, CT3, CT4, CT5, VT1	-
High	CT1, CT2, CT3, CT4, CT5, VT1, VT2, VT3, VT4	-
Sensor	CT4, CT5, VT1	RS1, RS2, RS3, VD1, VD2, VD3

A letter in the order number specifies whether the protection relay is equipped with basic, medium, high or sensor measuring input modules. (Refer to section “Ordering information” on page 61).

5.1.6.1. Scaling the rated values of the protected unit for analog channels

A separate scaling factor can be set for each analog channel. The factors enable differences between the ratings of the protected unit and those of the measuring device (CTs, VTs etc.) The setting value 1.00 means that the rated value of the protected unit is exactly the same as that of the measuring device.



When scaling factors are used, it should be noted that they affect the operation accuracy of the relay. The accuracies stated in the description of each function block (in the CD-ROM Technical Descriptions of Functions) only apply with the default values of the scaling factors. For example, a high factor affects the operation of sensitive protection functions such as the directional earth fault protection. To ensure the proper operation of the function blocks, it must be checked that the analog scales (pu scales) of the phase currents I_{L1} , I_{L2} , and I_{L3} , and correspondingly, the analog scales of the phase-to-phase voltages U_{12} , U_{23} , and U_{31} or phase-to-earth voltages U_1 , U_2 , and U_3 are identical.

The scaling factor is calculated channel by channel as follows:

Scaling factor = I_{nmd} / I_{np} , where

- I_{nmd} Rated primary current [A] of the measuring device
- I_{np} Rated primary current [A] of the protected unit connected to the channel

Example:

Rated primary current of current trafo = 500 A: $I_{nmd} = 500 \text{ A}$
 Rated current of the protected unit = 250 A: $I_{np} = 250 \text{ A}$
 Scaling factor for current channels: $500 \text{ A} / 250 \text{ A} = 2.00$

The scaling factors for the analog channels can be set via the HMI of the protection relay or with the Relay Setting Tool. The HMI path for the scaling factors is: Configuration\Protected unit\IL1: scaling, IL2: scaling...

5.1.6.2.

Technical data of the measuring devices

The technical data of the measuring devices is set using the Relay Setting Tool or via HMI. The set values (Configuration\Meas.devices\) will affect the measurements carried out by REX 521.

Values to be set for a current transformer:

- rated primary current (1...6000 A) of the current transformer
- rated secondary current (5 A, 2 A, 1 A, 0.2 A) of the current transformer
- rated current (5 A, 1 A, 0.2 A) of the current measuring input (= rated current of the matching transformer of the protection relay)
- amplitude correction factor (0.9000...1.1000) of the current transformer at rated current
- correction parameter for the phase displacement error of the current transformer at rated current (-5.00° ... 0.00°)
- amplitude correction factor of the current transformer at a signal level of 1% of the rated current (0.9000...1.1000)
- correction parameter for the phase displacement error of the current transformer at a signal level of 1% of the rated current (-10.00° ... 0.00°)

Values to be set for a voltage transformer:

- rated voltage of primary voltage transformer (0.100...440.000 kV)
- rated voltage of voltage input (same as the secondary rated voltage of the primary voltage transformer connected to the voltage input, 100 V, 110 V, 115 V, 120 V)
- amplitude correction factor of the primary voltage transformer voltage at rated voltage (0.9000...1.1000)
- correction parameter for the primary transformer phase displacement error at rated voltage (-2.00° ... 2.00°)

Values to be set for a current sensor (Rogowski coil):

- secondary rated voltage of the current sensor used at the preset primary rated current (100...300 mV)
- primary rated current of the current sensor used (1...6000 A)
- amplitude correction factor of the current sensor used at rated current (0.9000...1.1000)
- correction parameter for the phase displacement error of the current sensor (-1.0000° ... 1.0000°)

Values to be set for a voltage divider:

- division ratio of the voltage divider primary and secondary voltage (100...20000)
- rated value of primary phase-to-phase voltage (0.100...440.000 kV)
- amplitude correction factor of the voltage divider (0.9000...1.1000)
- correction parameter for the phase displacement error of the voltage divider (-1.0000°...1.0000°)

Calculation of correction parameters and factors:

The measurement values stated by the manufacturer of the measuring device are used for calculating the correction parameters and factors according to the following formulas:

Current transformers:

Amplitude error at current I_n (p = error in per cent)	Amplitude correction factor 1 $= 1 / (1 + p/100)$
Amplitude error at current $0.01 \times I_n$ (p = error in per cent)	Amplitude correction factor 2 $= 1 / (1 + p/100)$
Phase displacement error at current I_n (d = error in degrees)	Phase displacement error 1 = - d
Phase displacement error at current $0.01 \times I_n$ (d = error in degrees)	Phase displacement error 2 = - d

Voltage transformers:

Amplitude error at voltage U_n (p = error in per cent)	Amplitude correction factor $= 1 / (1 + p/100)$
Phase displacement error at voltage U_n (d = error in degrees)	Phase displacement error = - d

Rogowski coil:

Amplitude error at the whole measuring range (e = error in per cent)	Amplitude correction factor $= 1 / (1 + e/100)$
Phase displacement error at the whole measuring range (e = error in degrees)	Phase displacement error = - e

Voltage divider:

Amplitude error at the whole measuring range (e = error in per cent)	Amplitude correction factor $= 1 / (1 + e/100)$
Phase displacement error at the whole measuring range (e = error in degrees)	Phase displacement error = - e

5.1.6.3. Calculated analog channels

In case that no measuring devices are applied for measuring neutral current (I_0), the calculated (virtual) channel I_{0s} can be used in some of the configurations. See section “Select I_0 ” for information about how to take I_{0s} into use. Calculated U_0 is also used in some of the configurations in which no measuring device is available for the residual voltage (U_0). One configuration also includes calculated main voltages (U_{12s} , U_{23s} , U_{31s}), calculated from the measured phase voltages (U_1 , U_2 , U_3). For detailed information about in which configurations the calculated channels are used, see Table 2.-1 in REX 521 Technical Reference Manual, Standard Configurations (see Table 3.3.-1).

5.1.6.4. Select I_0

If the analog channel I_{0b} will be used for protection and measuring functions in the configuration it has to be enabled in the relay. Do this by selecting I_{0b} , 0.2/1 A from HMI or the Relay Setting Tool, path Configuration\Analog scales\Select I_0 . If the calculated I_{0s} will be used it can be enabled from the same place by selecting I_{0s} . In some configurations only the default setting I_0 , 1/5 A is available.

5.1.6.5. Rated frequency

The rated frequency of the protection relay can be set from from HMI or the Relay Setting Tool, path Configuration\Analog scales\Rated frequency. It can be set between 50 and 60 Hz, the default value is 50 Hz.

5.1.7. Digital inputs

The digital inputs of the protection relay are voltage-controlled and optically isolated. For technical data of the digital inputs, see Table 5.2.1-3 on page 48.

5.1.7.1. Filtering of digital inputs

The filter time eliminates debounces and short disturbances on digital inputs. The filter time may be set individually for each input.

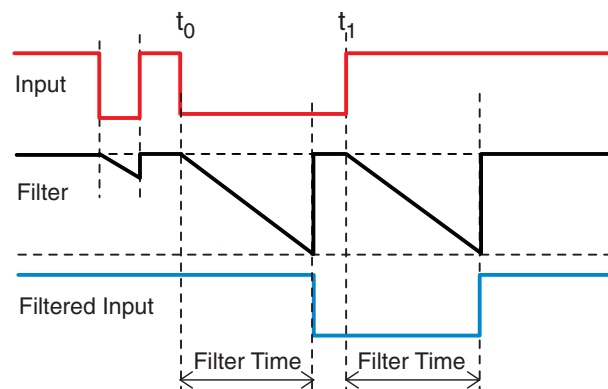

Fig. 5.1.7.1.-1 Filtering of a digital input

A051901

Fig. 5.1.7.1.-1 illustrates the input filtering. At the beginning, the input signal is at high state, the first low state is filtered and no input status change is detected. The second low state is longer than the set filter time, thus detected as a change and attached with the time tag t_0 . When the input signal returns to high state, after the filter time, the state is accepted and attached with the time tag t_1 .

Each digital input has a filter time parameter `Input # filter` (`Configuration\Digital inputs\Input filtering`), where # is the number of the input.

Table 5.1.7.1-1 Filter time parameter

Parameter	Values	Default
Input # filter	1...65535 ms	5 ms

A risk for debounces and short disturbances on digital inputs grows if the input filter time is changed to less than the default value.

5.1.7.2. Inversion of digital inputs

The status of digital inputs can be inverted with parameters accessible through the HMI or the Relay Setting Tool (`Configuration\Digital inputs\Input inversion`). When inverted, the status of a digital input is TRUE (1) when no control voltage is applied to the terminals, and FALSE (0) when the control voltage is applied.

5.1.8. Outputs

The outputs are categorized as follows:

- HSPO: High speed power output, single or double pole contact, for example for tripping purposes
- PO: Power output, single pole contact
- SO: Signal output, NO/NC (Normally open/Normally closed) contact

For detailed information about terminal connections, refer to the terminal diagrams. Technical data of the outputs is found in the section “Technical data” on page 48.

5.1.8.1. High-speed power output (HSPO)

The high-speed power output HSPO1 can be connected as a double-pole output where the object to be controlled (for example a circuit breaker) is electrically connected between the two relay contacts, see the Fig. 5.1.8.1.-1 below. The high-speed double-pole power output is recommended to be used for tripping purposes.

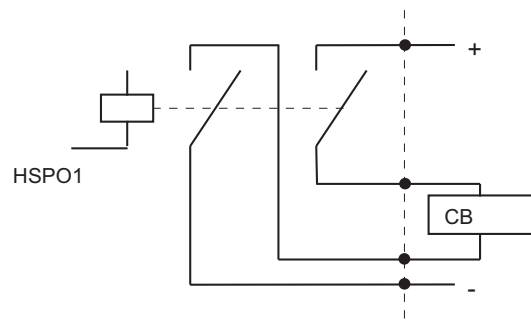

A051902

Fig. 5.1.8.1.-1 High-speed double-pole power output (HSPO)

The high-speed power output HSPO1 can also be connected as a single-pole power output where the object to be controlled (for example a circuit breaker) is electrically connected in series with the two relay contacts, see the Fig. 5.1.8.1.-2 below.

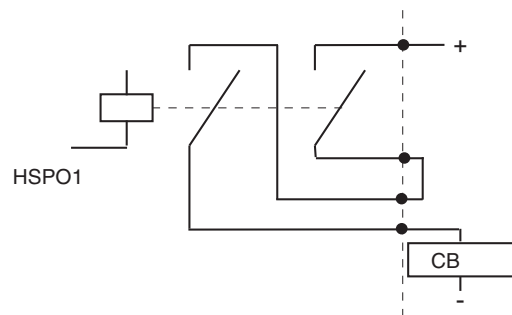

A051903

Fig. 5.1.8.1.-2 High-speed single-pole power output (HSPO)

5.1.8.2.

Single-pole power outputs (PO)

The single-pole power outputs PO1...3 are outputs where the object to be controlled is connected in series with two heavy-duty output relay contacts, see the Fig. 5.1.8.2.-1 below. These outputs can be used for tripping purposes and for circuit breaker and disconnector control. Two single-pole outputs may be used to obtain another double-pole output.

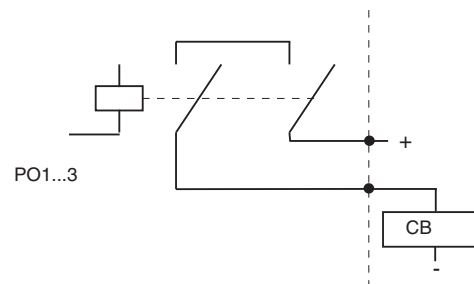

A051904

Fig. 5.1.8.2.-1 Single-pole power outputs (PO1...3)

5.1.8.3. Signalling outputs (SO)

The signalling relay outputs (SO1 and SO2) are not heavy-duty outputs and thus they cannot be used for controlling, for example, a circuit breaker. Available relay contacts are Normally Open/Normally Closed type (NO/NC), see the Fig. 5.1.8.3.-1 below. These outputs can be used for alarming and other signalling purposes.

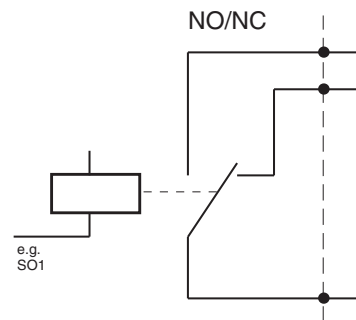

A051905

Fig. 5.1.8.3.-1 Signalling output (SO)

5.1.9. Testing inputs and outputs

The digital inputs and the output relays may be tested using the serial communication or the HMI.

Generally, the relay has to be in the test mode before the inputs and outputs can be activated. However, output relays may be activated through the serial communication without entering the test mode. This is to enable the usage of output relays for external purposes, not part of the protection and control in the host relay.

The test mode can be set with a parameter. The green READY LED indicator will be blinking, to announce that the test mode has been entered. In this state, the relay configuration is disconnected from the physical inputs so that changes on the digital inputs will not be noticed. When the test mode is deactivated, all test parameters requiring the test mode, will be reset.

The IRF relay may be tested by using the HMI. The IRF relay testing always requires entering the test mode.

When testing the general output relays, the user should notice, that normal operation of the relay cannot be disconnected. If an output relay is permanently activated by the configuration, it cannot be deactivated for testing.

For further information, see Operator’s manual (see “Related documents” on page 10).

Table 5.1.9-1 Testing of inputs and outputs

Test object	Using	Test mode required	Remarks
Digital inputs	HMI	Yes	Physical inputs disconnected
	Serial communication	Yes	
Output relays	HMI	Yes	Normal operation still active
	Serial communication	No	
IRF relay	HMI	Yes	
	Serial communication	Yes	

5.1.10.**Trip-circuit supervision**

The trip-circuit supervision consists of two functional units:

- A current limiter including the necessary hardware elements
- A software-based function block, named TCS1

The supervision of the trip circuit is based on the constant current injection principle. By applying an external voltage over the relay's trip contacts, a constant current is forced to flow through the external trip circuit. If the resistance of the trip circuit exceeds a certain limit, for instance due to a bad contact or oxidation, the supervision function will be activated and cause a trip-circuit supervision alarm signal after an adjustable delay time.

Under normal operating conditions, the applied external voltage is divided between the relay's internal circuit and the external trip circuit so that at the minimum 20 V (15...20 V) remains over the relay's internal circuit. Should the external circuit's resistance be too high or the internal circuit's too low, for example, due to welded relay contacts, the fault is detected.

Mathematically the operation condition can be expressed as:

$$U_c - (R_{ext} + R_{int} + R_s) \times I_c \geq 20 \text{ V AC/DC}$$

where:

- U_c = operating voltage over the supervised trip circuit
- I_c = measuring current through the trip circuit, appr. 1.5 mA (0.99...1.72 mA)
- R_{ext} = external shunt resistance
- R_{int} = internal shunt resistance, 1k Ω
- R_s = trip coil resistance

The external shunt resistance is used if the trip-circuit supervision, independent of the circuit-breaker position, is desired. If the trip-circuit supervision is required only in closed position, the external shunt resistance may be omitted.

Should the external shunt resistance be used, it has to be calculated not to interfere with the functionality of the supervision or the trip coil. Too high a resistance will cause too high a voltage drop, jeopardizing the requirement of at least 20 V over the internal circuit, while a resistance too low may enable false operations of the trip coil.

The following values are recommended for the external resistor R_{ext} :

Table 5.1.10-1 Values recommended for R_{ext}

Operating voltage U_C	Shunt resistor R_{ext}
48 V DC	1.2 k Ω , 5 W
60 V DC	5.6 k Ω , 5 W
110 V DC	22 k Ω , 5 W
220 V DC	33 k Ω , 5 W

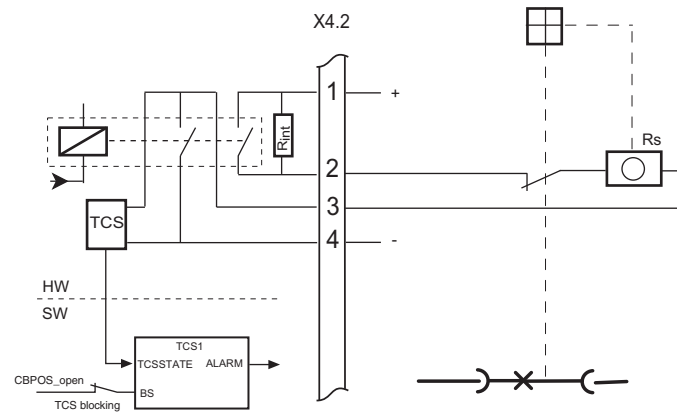

A051906

Fig. 5.1.10.-1 Operating principle of the trip-circuit supervision, without an external resistor. The TCS blocking switch is set, blocking the TCS1 when the circuit breaker is open.

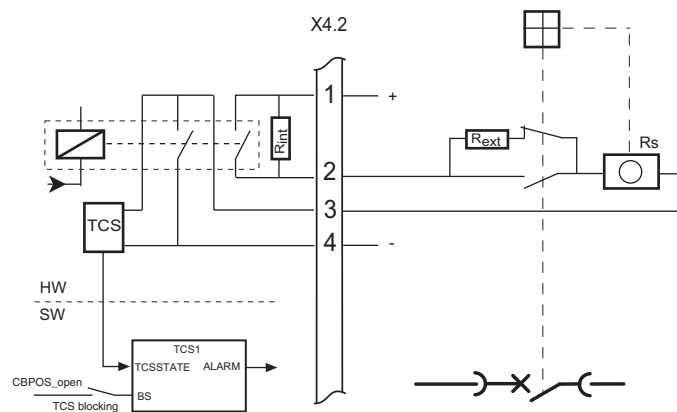

A051907

Fig. 5.1.10.-2 Operating principle of the trip-circuit supervision, with an external resistor. The TCS blocking switch is open, enabling trip-circuit supervision independent of circuit breaker position.

If there are more auxiliary contacts available, an opening contact can be series connected with the R_{ext} -resistor. The shunt-resistor circuit is opened when the CB is closed. Therefore the supervision of the auxiliary contact is also possible.

5.1.11. Self-supervision

In order to avoid false operations due to relay faults and to maximize the overall availability of the protection, a set of autodiagnostic circuit arrangements have been implemented in the relay modules.

The different memory circuits, that is, the RAM and the non-volatile memories, are continuously tested with different methods.

The microcontroller and the program execution are supervised by a watchdog once every 100 ms.

The selector, the A/D converter and other measuring input electronics are tested by checking a very accurate reference voltage once a minute. This is to ensure that a measured signal is real and not caused by a fault or disturbance in some input circuit, all to avoid false output signals.

Setting values are tested with the help of a checksum.

Furthermore, critical setting values are always checked to ensure that the values used are within the maximum and minimum limits.

The internal supply voltages from the power supply module are tested once a minute by measuring the voltages, +24 V, +15 V and -15 V.

The trip output paths, the output amplifiers and the output relay coils are checked once a minute by injecting a 50 μ s voltage pulse into the circuit and checking that current flows through the output relay coils. Both short-circuits and open coils are detected, since the rise time of the voltage pulse is measured.

Table 5.1.11-1 Self-supervision functions

Supervised object	Supervision method	Execution frequency
RAM memories	Write and read of all memory locations	40 B / 200 ms
Nonvolatile memories	Checksum	When data is fetched
Microcontroller and program execution	Internal watchdog	100 ms
A/D converter, multiplexer and amplifiers	Reference voltage	1 min
Setting values	Checksum, correct values	1 min
HMI (display)	Visual inspection	On connection of supply voltage
Power supply module	Measurement of supply voltages	1 min
Output amplifiers and relay coils	Feedback from the relay coils	1 min

When the self-supervision detects a fault, different measures are taken depending on the severity of the fault. If the fault is fatal, the microcontroller tries to get the system to work by restarting ten times. If this attempt is not successful, a signal about the internal relay fault (IRF) is linked to the output relay. Provided that the unit is operating normally, the information about the fault is sent as an event "IRF activated" (E31) over the serial communication and the green READY LED on the front panel starts blinking. An indication about the character of the fault is also shown as a textual message on the display.

If the fault is considered too dangerous to maintain normal protection, an inoperative IRF state is entered and no output relay operations are allowed. On the other hand if, for example, one output relay is found faulty and the others healthy, normal operations targeted to a healthy relay are allowed.

Even a total breakdown of the relay, for example, on loss of power supply, will be detected as the IRF relay operates in a fail-safe mode, causing a signal when the relay drops off. The serial communication will also indicate loss of contact to the module. When the relay is in the IRF state, it tries to recover by restarting every five minutes.

As long as the fault remains, the relay continues to perform internal tests. Should the fault prove to be of temporary nature, normal operation is recovered after restart and an event “IRF reset” (E30) is sent over the serial communication.

5.1.11.1. Fault indication

The self-supervision signal output operates on the closed circuit principle. Under normal conditions the output relay is energized and the contact gap 3-5 is closed. Should the auxiliary power supply fail or an internal fault be detected, the contact gap 3-5 is opened.

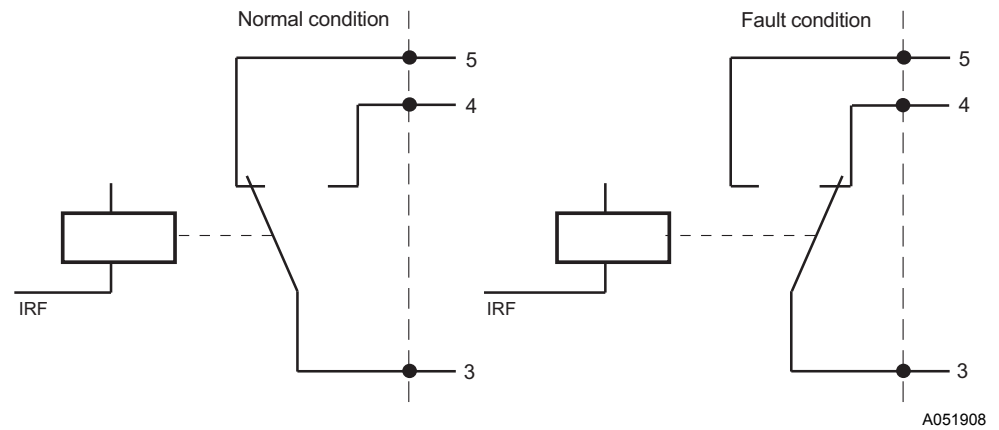

Fig. 5.1.11.1.-1 Self-supervision output (IRF)

When a fault has been detected, the green READY LED indicator starts blinking, a fault indication text is displayed on the HMI and an event “IRF activated” (E31) is generated over serial communication.

5.1.11.2. Fault indication texts

The table below shows the different fault indication texts that may appear, the corresponding fault codes and the actions that should be taken. The fault code is only used for remote control systems connected to the serial communication.

Table 5.1.11.2-1 Fault indications

Fault indication	Fault code	Reason/Action
INTERNAL FAULT Relay HSPO1	1	Protection operative, but the faulty output relay cannot be controlled
INTERNAL FAULT Relay PO1	7	Protection operative, but the faulty output relay cannot be controlled
INTERNAL FAULT Relay PO2	8	Protection operative, but the faulty output relay cannot be controlled
INTERNAL FAULT Relay PO3	9	Protection operative, but the faulty output relay cannot be controlled
INTERNAL FAULT Relay SO1	15	Protection operative, but the faulty output relay cannot be controlled
INTERNAL FAULT Relay SO2	16	Protection operative, but the faulty output relay cannot be controlled
INTERNAL FAULT Relay control	20	Protection inoperative. An attempted relay control operation failed.
INTERNAL FAULT Relay test	21	Protection inoperative. Two or more relays were found faulty during test.
INTERNAL FAULT NOV error	30	Protection inoperative. Nonvolatile memory error. The corrupted data cannot be used. May be solved by restoring the factory settings.
INTERNAL FAULT EEPROM error	40	Protection inoperative
INTERNAL FAULT RAM error	50	Protection inoperative
INTERNAL FAULT IRF error (test)	60	Protection operative
INTERNAL FAULT HMI error	70	Protection operative. The fault indication may not be seen on the HMI during the fault.
INTERNAL FAULT Overtemperature	80	Protection operative. The relay has detected an excessive temperature. May be due to an ambient temperature above the specified operating limit or an internal fault.
INTERNAL FAULT Voltage low 24V	131	Protection operative. Output relays do not operate within specified limits.
INTERNAL FAULT Volt. high +15V	203	Protection inoperative
INTERNAL FAULT Volt. high -15V	223	Protection inoperative
INTERNAL FAULT A/D conversion	253	Protection inoperative
INTERNAL FAULT Start-up	-	Protection inoperative. No communication started, menu navigation disabled.
INTERNAL FAULT Unspecified	255	Protection operative or inoperative. The fault location cannot be determined.

5.1.12. Serial communication

The protection relay has two serial communication ports, one on the front panel and the other on the rear panel.

The connector located on the front panel is a standard ABB optical connector that is intended to be used for setting the parameters of the protection relay. During the transmission of the parameters, an interface cable is connected between the relay and the standard RS-232 interface of a PC, running the Relay Setting Tool.

On the rear panel, there is a fibre-optic interface used to connect the protection relay to a distribution automation system via SPA, LON, IEC 60870-5-103, Modbus or DNP 3.0 bus.

There is also an isolated RS-485 connection (twisted pair) available for SPA, Modbus and DNP 3.0 communication in connector X3.1:9,10. For the location of the RS-485 connection on the rear panel, see “Terminal connections” on page 57. The connection is marked with texts “Data A” and “Data B” on the panel.

The following table describes the combinations of different communication protocols and the physical interfaces that can be used at the same time (X = in use).

Table 5.1.12-1 Protocol combinations and physical interfaces

Protocol	Rear port (Optical)	Rear port (RS-485)	Front connector (SPA only)
SPA	X		X
SPA		X	X
LON	X		X
IEC_103	X		X
Modbus	X		X
Modbus		X	X
DNP 3.0	X		X
DNP 3.0		X	X

5.1.12.1. Optical communication port on the rear panel

The fibre-optic interface on the rear panel contains two optical connectors, Tx (X3.2) and Rx (X3.3). The connectors are used for interfacing the unit to an optical fibre bus using either plastic fibre or glass fibre cables. See also Fig. 5.1.12.5.-2 on page 38 for more information about the plastic and glass fibre cables.

The incoming optical fibre is connected to the receiver, input Rx, and the outgoing optical fibre to the transmitter, output Tx. Special attention should be paid when handling, mounting, and connecting fibre-optic cables. For additional information, see the document 34 SPA 13 EN1 Plastic-core fibre-optic cables. Features and instructions for mounting.

The communication port supports five different protocols, SPA, LON, IEC 60870-5-103, Modbus and DNP 3.0. The SPA, IEC_103, Modbus and DNP 3.0 protocols are always supported while LON is not available in all the relay variants. The relay does not automatically recognize which bus it is connected to and therefore the protocol must be set manually through the HMI or the Relay Setting Tool (Main menu \ Configuration \ Communication \ Rear port). For rear port options, see Table 5.1.12.2-1.

5.1.12.2. Isolated RS-485 connection on the rear panel

The RS-485 port is used for connecting the unit to the communication bus by using twisted pair cable. When the shielded twisted pair cable is used (recommended), the shield can be connected to the earthing connector which is located on the rear panel (see “Terminal connections” on page 57).

The communication port can be used with three different protocols: SPA, Modbus and DNP 3.0. The user must set the selected protocol manually by using the HMI or the Relay Setting Tool

(Main menu\Configuration\Communication\Rear port). For options, see the table Table 5.1.12.2-1.

Table 5.1.12.2-1 Rear port options

Option	Rear port
SPA	optical
LON	optical
IEC_103	optical
Modbus	optical
SPA - RS485	RS-485
Modbus - RS485	RS-485
DNP 3.0 - RS485	RS-485
DNP 3.0	optical

5.1.12.3. Front panel optical connection for a PC

The front connector is standardized for ABB relay products and requires an opto-cable (ABB art. No 1MKC950001-2).

The connector supports only the SPA bus protocol, and is connected to the RS-232 port of a standard PC. By using an optical connector, the PC is isolated galvanically from the protection relay and disturbances are minimized.

Parameters for the serial communication, SPA address, Baud rate and Slave status, can be changed manually in the HMI.

To ensure fluent communication flow, it is recommended to use 9.6 kbps baud rate.

5.1.12.4. The service pin located on the rear panel

The service pin located above the connector X3.2 is used only in systems communicating over the LON bus. The service pin is used during the installation process or in fault detection. When the service pin is pressed, the neuron_id is sent to the LON bus.

5.1.12.5. SPA bus

The SPA bus protocol uses an asynchronous serial communication protocol (1 start bit, 7 data bits + even parity, 1 stop bit). Adjustable parameters are Baud rate (default 9,6 kbps) and SPA address (slave number). The communication parameters for the front and the rear communication ports can be set individually. The SPA bus protocol is sending events using event mask 1 (“V101” parameter of each function block). The SPA event buffer stores the first 50 events.

Technical Reference Manual, General

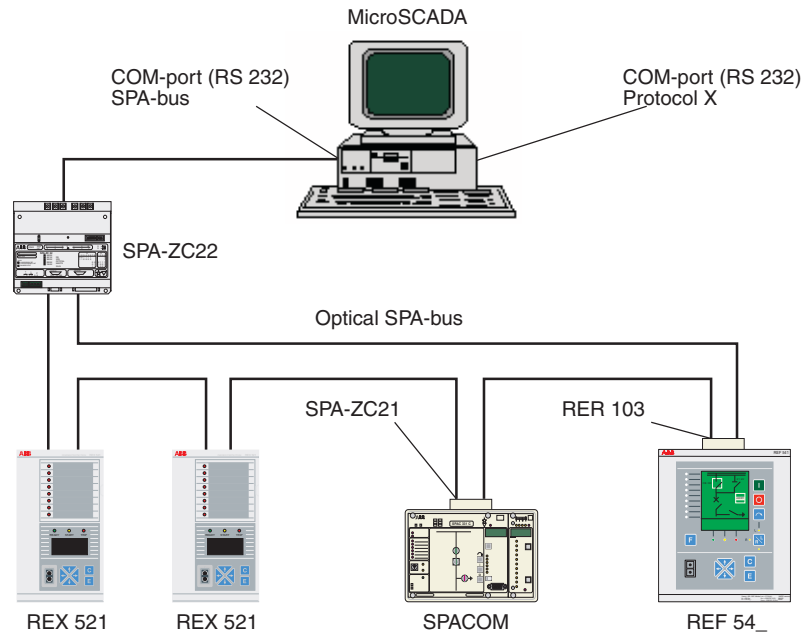

A051909

Fig. 5.1.12.5.-1 Example of a SPA-based substation automation system

In the case of longer transmission distance, for example between MicroSCADA system and a substation, the system configuration presented in Fig. 5.1.12.5.-2 is recommended.

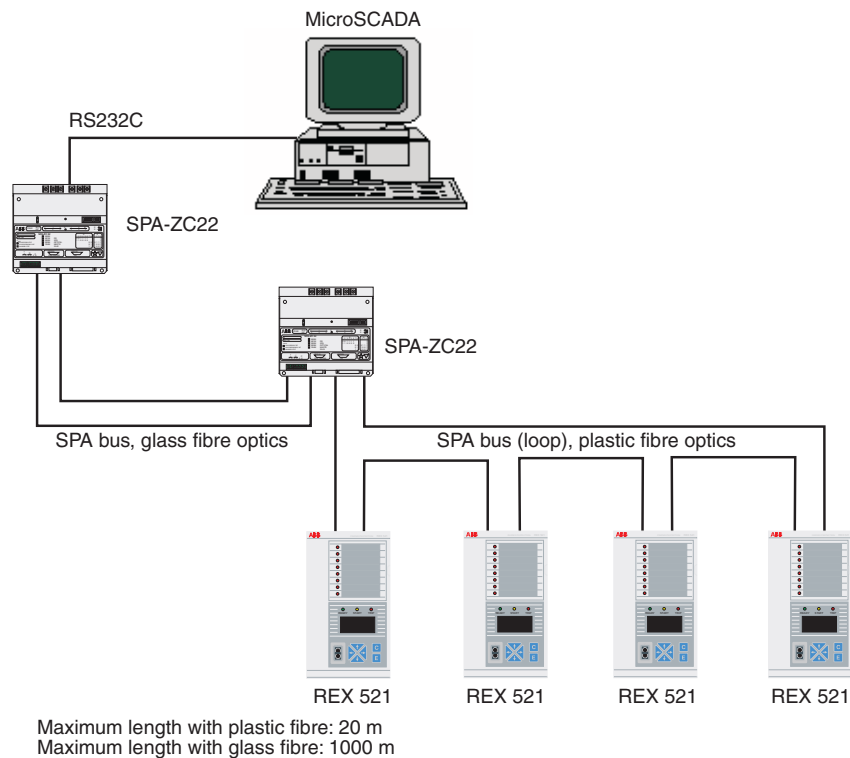

A051910

Fig. 5.1.12.5.-2 Example of a SPA-based substation automation system with a longer transmission distance

5.1.12.6.**LON**

The protection relay is able to interface to the substation automation system with the LON communication protocol. The LON communication between REX 521 and the host device, for example MicroSCADA, is based on LAG (Lon Application Guideline) version 1.4. The REX 521 LON communication includes vertical communication of process data and parameter data between the protection relay and the host device.

The system very often resembles the system in Fig. 5.1.12.6.-1. The protection, control or alarm functions are implemented by using REX 521 protection relays and other RED 500 series protection relays, SPACOM units or other SPA bus devices (devices connected to the system via the SPA bus). LON devices made by other manufacturers or other ABB companies may be used for various DI, AI and DO functions. MicroSCADA is used for remote control.

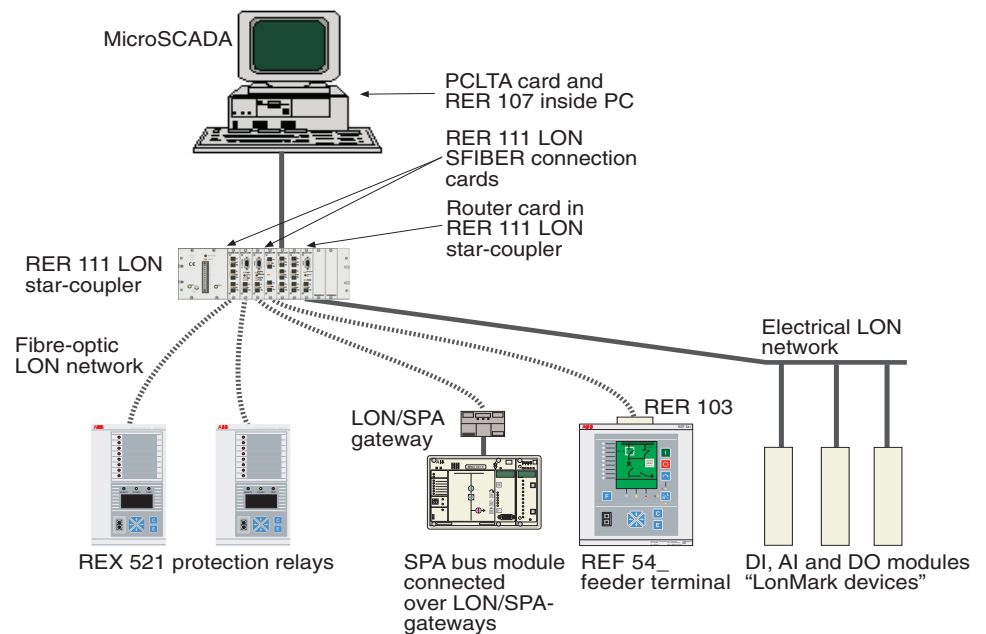

A051911

Fig. 5.1.12.6.-1 Example of a LON-based substation automation system

In the system described in Fig. 5.1.12.6.-1, communication is usually arranged as shown in the table below.

Data type	REX ↔ MicroSCADA
Events and alarms	sliding window protocol
Control commands	sliding window protocol transparent SPA bus messages
Status of breakers and isolators	sliding window protocol
Analog measurement values	sliding window protocol
Other DI, AI data	sliding window protocol
Other DO data	transparent SPA bus messages
Parameter data	transparent SPA bus messages
Disturbance recorder data	file transfer over the LON network

The LAG 1.4 default communication settings may be loaded by selecting `Execute` from the HMI (`Configuration\Communication\Comm.settings\LON\Load def config.`). This operation blanks the internal EEPROM and boots the Neuron chip. Thereafter, the default communication settings are loaded and stored into the Neuron chip. This operation takes approximately 15 seconds according to LAG 1.4.¹

From the front panel, the user should configure the `Node number`, the `Subnet number` and the `Bit rate` in REX 521.

The LON bus event buffer includes 150 last events.

5.1.12.7. IEC 60870-5-103 bus

The REX 521 includes an unbalanced IEC 60870-5-103 slave communication interface.

The interface provides a fixed cross-coupling between the REX 521 application (indications, commands and protection equipment) and the IEC 60870-5-103 protocol application data. The adjustable parameters are `Baud rate` and `Unit address`. User-selectable measurand sets `Frame type` are available for the analog measurement values.

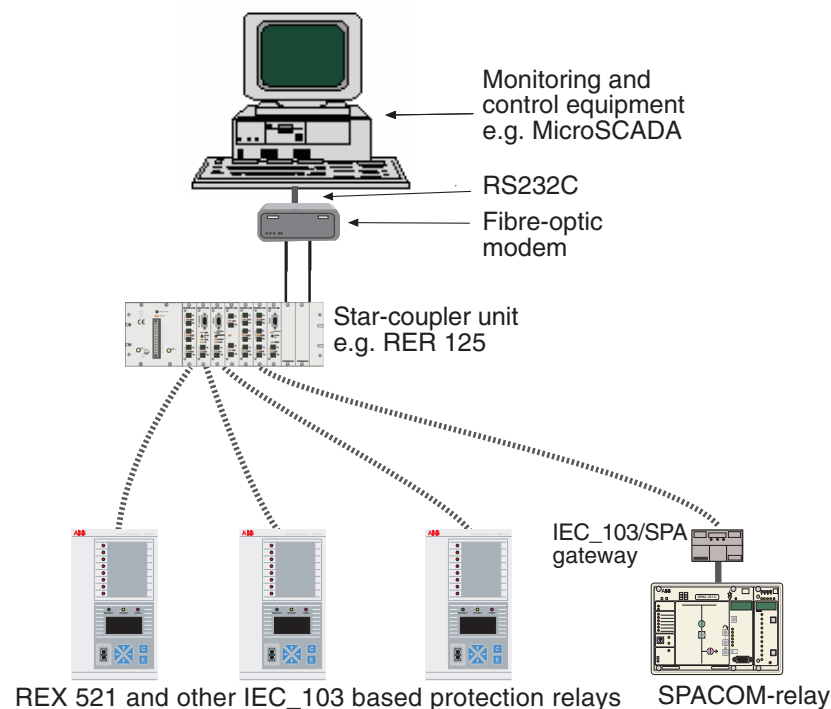

A051912

Fig. 5.1.12.7.-1 Example of the physical connection of the IEC 60870-5-103 control system

1. In order to succeed, the LON protocol has to be selected as the rear port protocol.

The physical bus topology is star-based. A star-coupler unit, for example RER 125, is needed for connecting the REX 521 unit to a control system. The line idle state of the fibre-optic interface is configurable (“light on” and “light off”) with a parameter Tx mode.

For more information about the IEC 60870-5-103 bus, see “Appendix A: IEC 60870-5-103 bus” on page 65.

5.1.12.8.

Modbus

The REX 521 has a slave communication interface for Modbus system. Both ASCII and RTU mode are supported.

The communication technique used in Modbus protocol is a master-slave technique. The master can be connected to the slaves either directly or via modems by using a compatible serial interface. However, only the direct connection can be used with REX 521.

At physical level, the Modbus systems may use different physical interfaces, for example, RS-485 or RS-232 (see Fig. 5.1.12.8.-1). Both the RS-485 two-wire interface and the optical RS-232 interface are supported by REX 521. The recommended RS-485 bus topology with Modbus is a chain of devices with line terminations at the both ends of the bus.

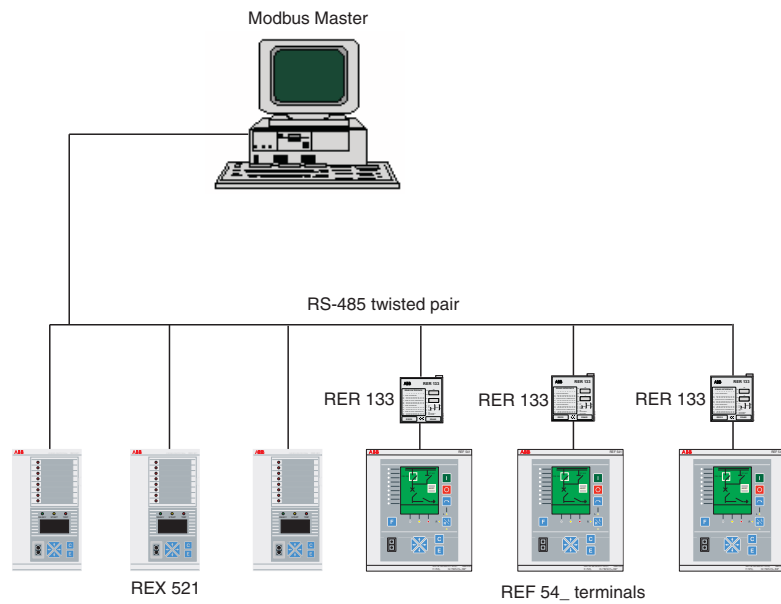

A051913

Fig. 5.1.12.8.-1 Example of a Modbus system

The adjustable parameters via HMI for Modbus communication in REX 521 are CRC Order, Modbus Mode, Unit Address, Baud rate, No of stop bits, No of data bits, End of frame TO, and Parity.



When using the RTU mode, every time the bit rate parameter (Baud rate) is reconfigured, that is, the value is changed, the software of REX 521 also recalculates the default value for the timeout parameter (End of frame TO). Therefore, to manually enforce the timeout value, the timeout parameter must always be set after the Baud rate parameter is configured. In this case it is recommended to set the parameter value to a longer timeout than the calculated default value with the Baud rate parameter in question.

For more information on Modbus, see Modbus Remote Communication Protocol for REX 521, Technical Description (see “Related documents” on page 10).

5.1.12.9.

DNP 3.0 Bus

The REX 521 can also be connected to a DNP 3.0 system.

The DNP 3.0 protocol is used in a substation automation system for connecting the protection devices to a system level device. A daisy chain network configuration is used and the physical interface is made by two-wire RS-485 (see Fig. 5.1.12.9.-1). It is also possible to use an optical RS-232 interface (star-topology) for DNP 3.0 in REX 521.

The transmission speed is configurable up to 19200 kbits/s and support for unsolicited messages is included.

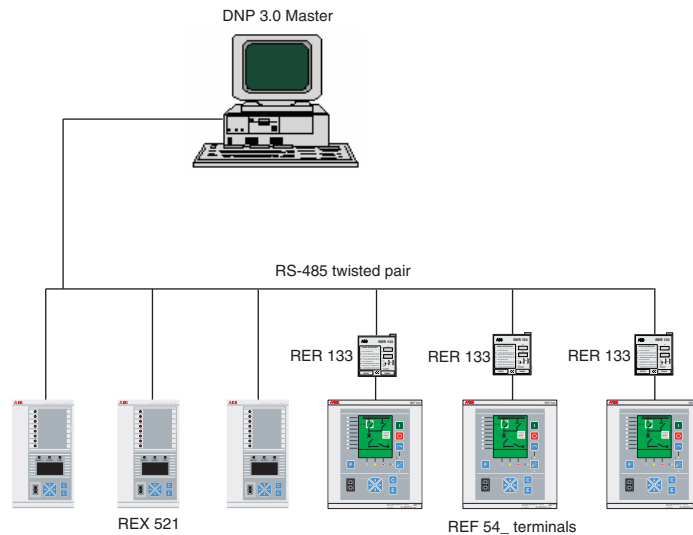

A051914

Fig. 5.1.12.9.-1 Example of a DNP 3.0 system

For more information of DNP 3.0 in REX 521, see the manual DNP 3.0 Communication Protocol for REF 54_, RET 54_ and REX 521, Technical Description (see “Related documents” on page 10).

5.1.12.10. IEC 61850 communication by using SPA-ZC 402

REX 521 can communicate with the IEC 61850 protocol by connecting a SPA-ZC 402 SPA/Ethernet adapter to the rear optical connection. The SPA-ZC 402 SPA/Ethernet adapter also offers the possibility to access the REX 521 relay with the SPA protocol over TCP/IP using the same Ethernet link.

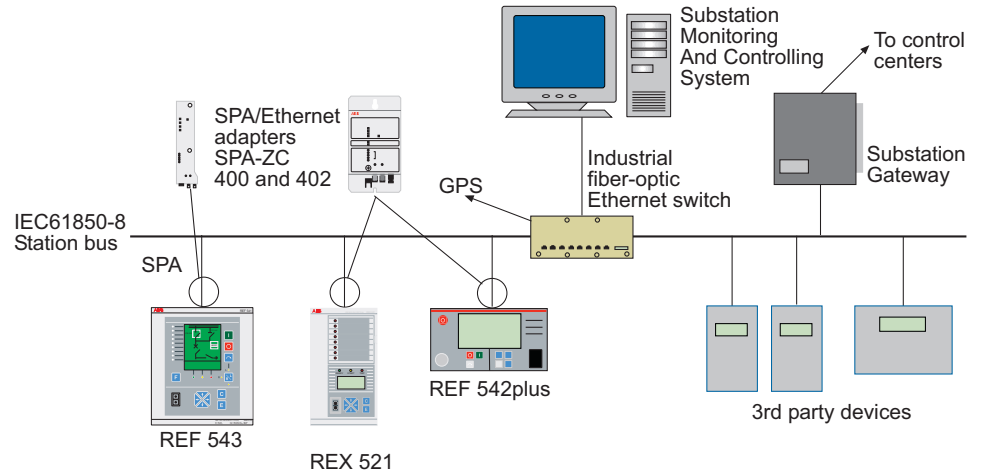

A060011

Fig. 5.1.12.10.-1 IEC61850-based substation automation system

5.1.12.11. Profibus-DPV1 communication by using SPA-ZC 302

The SPA-ZC 302 Profibus-DPV1/SPA Gateway is used to enable communication between REX 521 and a Profibus system. The SPA-ZC 302 Gateway should be connected to the RS485 port on REX 521 when used as a single SPA slave. If a SPA loop is used, the optical rear port is used. In both cases, the SPA REAR parameter should be set to the same baud rate as the SPA-ZC 302 Gateway.

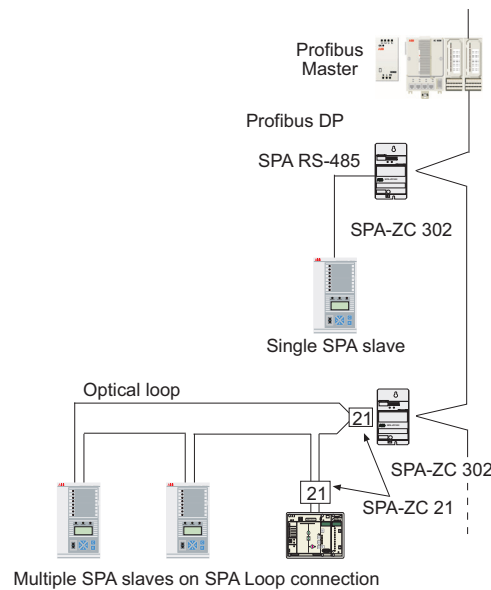

Multiple SPA slaves on SPA Loop connection

A060012

Fig. 5.1.12.11.-1 Profibus-based substation automation system

5.1.13.**Time synchronization**

The time synchronization (`Configuration\Time`) of the protection relay can be given from different sources:

1. The time can always be given manually from the front panel.
2. The time synchronization can also be given externally. The master parameter for external synchronization source selection is called `Sync.source`. This parameter can have two different states:
 - “Net Messages” state
 - “X3.1.2 Input” state

“Net Messages” state

The parameter should be in the “Net Messages” state if the time synchronization is taken from one of the following sources:

SPA bus

- Time synchronization is received from the SPA master device.

IEC 60870-5-103 bus

- Time synchronization is received from the IEC 60870-5-103 master device.

LON bus in the following cases:

- Time synchronization message is received from the `SNVT_Timestamp` input network variable.
- Time synchronization message is received from the `nv_warning/nv_clock` input network variables.

Some additional comments:

The `SNVT_Timestamp` network variable selector is `0x2FF5` (fixed).

The `nv_warning` and `nv_clock` selector values are `0x2FFE` and `0x2FFF` respectively (also fixed).

“X3.1.2 Input” state

Synchronization is received from the digital input DI9. The input can act either as a minute or a second synchronization input depending on the setting of the parameter `Sync.rounding`. Furthermore, it is possible via the parameter `Sync.trigg.slope` to set the pulse edge (positive or negative) which triggers the synchronization.

Accuracy

When there is no external synchronization, the roaming time is better than 3 ms/min. It is recommended that the relay is synchronized once a second in order to achieve optimal accuracy.

5.1.14. Display panel (HMI)

The front panel of the relay includes:

- A 6 x 16 character LCD
- Three protection indication LEDs
- Eight alarm LEDs
- Arrow buttons for menu navigation
- Optically isolated serial communication port

Additional features of the display:

- Contrast adjustment with temperature compensation
- Backlight control

5.1.15. Indication LEDs

The relay is provided with three indication LEDs (green, yellow and red). With latching/non-latching, steady/blinking light the LEDs indicate different states and operations of the relay. For more information, see Operator's Manual.

5.1.16. Alarm LEDs

The relay is provided with eight alarm LED indicators (red). With latching/non-latching or steady/blinking light the alarm LEDs indicate different states and operations of the relay. The user can freely enable and disable the predefined alarms. By default, all the alarms are disabled. To enable alarms, do the following:

1. Select a mode (Control\ALARM#\Control setting\Object mode) for function blocks MMIALAR1-8 (these are uninitialized by default). The mode you selected affects the behaviour of the alarms coming to a certain LED. MMIALAR1 affects LED1, MMIALAR2 affects LED2, and so on. Three alarm modes are supported regarding latching: non-latched, latched with steady LED, and latched with blinking LED. For more information about MMIALAR function blocks, see Technical Reference Manual, Standard Configurations ("Related documents" on page 10).
2. Enable the alarms by setting the bitmask for the LED (Configuration\Alarm LEDs\LED1, LED2..)

The alarms can be acknowledged (cleared) from the main view by pressing the [C] button for 2 s. This acknowledges all the alarms.

For a certain MMIALAR function block, the alarms can also be acknowledged by selecting "Acknowledge" for parameter Alarm ack (Control\ALARM#\Control setting\Alarm ack). This acknowledges alarm(s) only for the corresponding LEDs. After the acknowledgement, the status of a certain LED (off/steady/blinking) depends on the selected mode and whether the alarm is still active or not.



After an auxiliary supply break, the state of the alarm LEDs is restored to the same state as before the break. This means that alarms will be seen even if the alarm went off during the break and regardless of the mode. The alarms can be acknowledged (cleared) only from the main view by pressing the [C] button for 2 seconds

5.1.16.1. Special features of alarm LEDs

It is also possible to activate alarm LEDs by writing to parameter Alarm LED states from HMI, or by using serial communication. This works even if the alarms are not enabled (enabling alarms, see “Alarm LEDs” on page 45). The value written to that parameter is then logically combined together (by an OR function) with alarms enabled as described in the previous section.

The actual state of the alarm LEDs can also be read from the parameter Alarm LED states by using serial communication, or by reading the state from HMI (Configuration\Display\Alarm LED states).

In the HMI, the state of the alarm LEDs is shown bit-wise starting from the right with LED1. The LEDs that were activated by writing to parameter Alarm LED states can be acknowledged by pressing the [C] button for 2 s in the main view.

Clearing a certain LED without affecting the other LEDs can be done by setting the corresponding bit to 0 in parameter Alarm LED states. Writing to parameter Alarm LED states from HMI is useful when testing if a certain LED lights up.

5.1.16.2. Writing signal names on alarm LED label

You can write or print the alarm LED signal names on a special label presented in Fig. 5.1.16.2.-1. The transparencies for the label are delivered with the relay. The label contains eight text rows, one for each alarm LED.

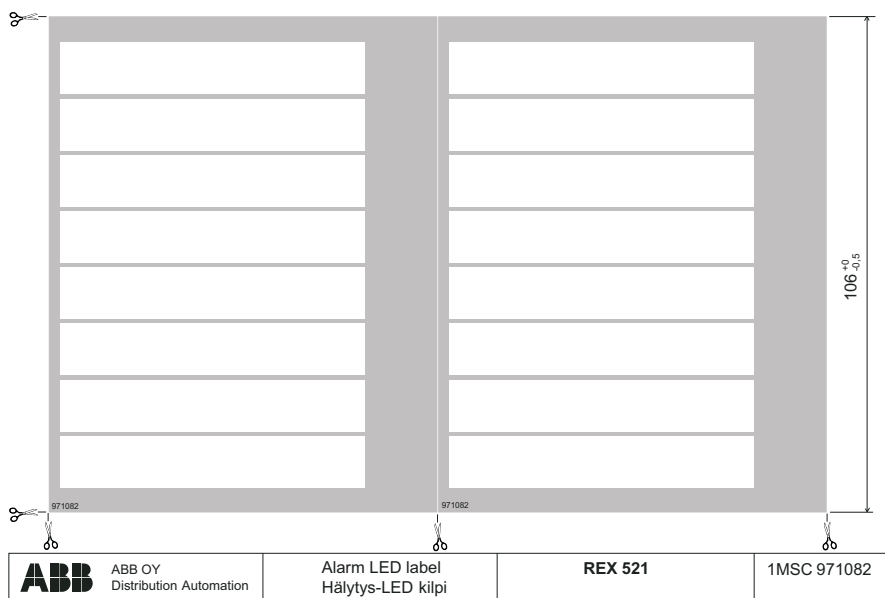

A051915

Fig. 5.1.16.2.-1 Alarm LED label

When writing signal names on the label by hand

1. Use the pre-printed transparency.
2. Write the names on the transparency with permanent pen or by typewriter.
3. Put the label in the pocket on the front panel of REX 521.

When writing signal names on the label by using computer

1. Select a template for the label. The templates can be found in Technical Descriptions of Functions CD-ROM (see “Related documents” on page 10) and in the Internet address www.abb.com/substationautomation (under Shortcuts, select the option REX 521 from the Distribution products list box).
 - Excel-format template (Label1MRS151301.xls) can be used when you want to save the signal names for example on the hard disk of your PC.
 - Pdf-format template (Label1MRS151300.pdf) can be used when you use Acrobat Reader and only want to print the signal names on the label.
2. Depending on printer, the print size may vary: test print the label on paper before printing it on transparency. To adjust the print height to the maximum height of the label (106 mm), use the zoom option of the printer settings.
3. Print the label on the blank transparency. It is recommended to write and print two labels at the same time since the templates contain two labels to fill the signal names in.



Use only laser printers for printing. Ink jet printers are not suitable for printing on label transparencies.

4. Put the label in the pocket on the front panel of REX 521.

5.2. Design description

5.2.1. Technical data

Table 5.2.1-1 Energizing inputs

Rated frequency		50.0/60.0 Hz	
Current inputs	Rated current		0,2 A/1 A/5 A
	Thermal withstand capability	continuously	1.5 A/4 A/20 A
		for 1 s	20 A/100 A/500 A
	dynamic current withstand, half-wave value		50 A/250 A/1250 A
input impedance		<750 mΩ/<100mΩ/<20 mΩ	
Voltage inputs	rated voltage		100 V/110 V/115 V/120 V (parametrization)
	voltage withstand, continuous		2 x U _n (240 V)
	burden at rated voltage		<0.5 VA
Sensor inputs	voltage range RMS		9.4 V RMS
	voltage range peak		± 12 V
	input impedance		>4.7 MΩ
	input capacitance		<1 nF

Table 5.2.1-2 Auxiliary power supplies

Type	PS_87H (REX521xxHxx)	PS_87L (REX521xxLxx)
Input voltage, AC	110/120/220/240 V	-
Input voltage, DC	110/125/220 V	24/48/60 V
Voltage variation	AC 85...110%, DC 80...120% of rated value	DC 80...120% of rated value
Burden	<20 W	
Ripple in DC auxiliary voltage	max. 12% of the rated DC value (IEC 60255-11)	
Interruption time in auxiliary DC voltage without resetting	<40 ms, 110 V	<15 ms, 24 V
	<100 ms, 200 V	<50 ms, 48 V
Internal overtemperature indication	+78°C (+75...+83°C)	

Table 5.2.1-3 Digital inputs

Type	PS_87H (REX521xxHxx)	PS_87L (REX521xxLxx)
Operating range, DC	80...265 V DC DI9: 18...265 V	18...265 V
Input voltage, DC	DI1...DI8: 110/125/220 V DI9: 24/48/60/110/125/220 V)	DI1...DI9: 24/48/60/110/125/220 V
Current drain	~2...25 mA	
Power consumption/input	<0.8 W	

Table 5.2.1-4 Signal outputs

Max. system voltage	250 V AC/DC
Continuous carry	5 A
Make and carry for 0.5 s	10 A
Make and carry for 3 s	8 A
Breaking capacity when control circuit time-constant L/R <40 ms, at 48/110/220 V DC	1 A/0.25 A/0.15 A

Table 5.2.1-5 Power outputs

Max. system voltage	250 V AC/DC	
Continuous carry	5 A	
Make and carry for 0.5 s	30 A	
Make and carry for 3 s	15 A	
Breaking capacity when control circuit time constant L/R <40 ms, at 48/110/220 V DC	5 A/3 A/1 A	
Minimum contact load	100 mA, 24 V AC/DC (2.4 VA)	
TCS (Trip-circuit supervision)	Control voltage range	20...265 V AC/DC
	Current drain through the supervision circuit	approx. 1.5 mA (0.99...1.72 mA)
	Minimum voltage (threshold) over a contact	20 V AC/DC (15...20 V)

Table 5.2.1-6 Environmental conditions

Specified service temperature range	-10...+55°C	
Transport and storage temperature range	-40...+70°C	
Enclosure class	Front side, flush-mounted	IP 54
	Rear side, connection terminals	IP 20
Dry heat test	according to IEC 60068-2-2	
Dry cold test	according to IEC 60068-2-1	
Damp heat test, cyclic	according to IEC 60068-2-30, r.h. >93%, T = 25...55°C	
Storage temperature tests	according to IEC 60068-2-48	

Table 5.2.1-7 Standard tests

Insulation tests	Dielectric test IEC 60255-5	Test voltage	2 kV, 50 Hz, 1 min.
	Impulse voltage test IEC 60255-5	Test voltage	5 kV, unipolar impulses, waveform 1,2/50 μs, source energy 0.5 J
	Insulation resistance measurements IEC 60255-5	Insulation resistance	> 100 MΩ, 500 V DC
Mechanical tests	Vibration tests (sinusoidal)		IEC 60255-21-1, class I
	Shock and bump test		IEC 60255-21-2, class I
	Seismic test		IEC 60255-21-3, class 2

Table 5.2.1-8 Electromagnetic compatibility tests

The EMC immunity test level fulfills the requirements listed below		
1 MHz burst disturbance test, class III, IEC 60255-22-1	common mode	2.5 kV
	differential mode	1.0 kV
Electrostatic discharge test, class III IEC 61000-4-2 and 60255-22-2	for contact discharge	6 kV
	for air discharge	8 kV

Table 5.2.1-8 Electromagnetic compatibility tests (Continued)

Radio frequency interference test	conducted, common mode IEC 61000-4-6, IEC 60255-22-6	10 V (rms), f = 150 kHz...80 MHz
	radiated, amplitude-modulated IEC 61000-4-3, IEC 60255-22-3	10 V/m (rms), f = 80...1000 MHz
	radiated, pulse-modulated ENV 50204, IEC 60255-22-3	10 V/m, f = 900 MHz
Fast transient disturbance test IEC 60255-22-4 and IEC 61000-4-4	power supply	4 kV
	I/O ports	2 kV
Surge immunity test IEC 61000-4-5 and IEC 60255-22-5	power supply	2 kV, common mode 1 kV, differential mode
	I/O ports	2 kV, common mode 1 kV, differential mode
Power frequency (50 Hz) magnetic field IEC 61000-4-8	100 A/m continuous 300 A/m 1 to 3 s	
Voltage dips and short interruptions IEC 61000-4-11	30%, 10 ms; 60%, 100 ms; 60%, 1000 ms >90%, 5000 ms	
Electromagnetic emission tests EN 55011 and EN 60255-25	conducted RF emission (mains terminal)	EN 55011, class A, EN 60255-25
	radiated RF emission	EN 55011, class A EN 60255-25
CE approval	Complies with the EMC directive 89/336/EEC and the LV directive 73/23/EEC.	EN 50263 EN 50081-2 EN 61000-6-2 EN 60255-6

Table 5.2.1-9 Data communication

Rear interface, connector X3.2 and X3.3	Fibre-optic interface	
	protocols	SPA, IEC_103, Modbus, DNP 3.0 Also LON in the REX 521 xxxxL versions.
Rear interface, connector X3.1:9,10	using SPA-ZC 402 SPA/Ethernet Adapter:	
	protocols	IEC 61850, SPA TCP/IP
Rear interface, connector X3.1:9,10	RS-485 connection	
	protocols	SPA, Modbus, DNP 3.0
Front panel	using SPA-ZC 302 Profibus-DPV1/SPA Gateway:	
	protocol	Profibus
SPA protocol	optical RS 232 connection	
	protocol	SPA
	communication cable	1MKC950001-2
IEC_103 protocol	baud rates	4.8/9.6/19.2 kbps
	start bits	1
	data bits	7
	parity	even
	stop bits	1
IEC_103 protocol	baud rates	9.6/19.2 kbps
	data bits	8
	parity	even
	stop bits	1

Technical Reference Manual, General

Table 5.2.1-9 Data communication (Continued)

Modbus protocol	baud rates	0.6/1.2/2.4/4.8/9.6/19.2 kbps
	data bits	7/8 (ASCII/RTU)
	parity	no parity/odd/even
	stop bits	1/2
	Modbus modes	ASCII, RTU
DNP 3.0 protocol	baud rates	0.3/0.6/1.2/2.4/4.8/9.6/19.2 kbps
	data bits	8
	parity	no parity/odd/even
	stop bits	1/2
LON protocol	bit rates	78.0 kbps/1.25 Mbps

Table 5.2.1-10 General

Toolboxes	CAP 501, CAP 505, LIB 510, SMS 510
Events	All events are recorded in higher level syntax: reason, time, date are in clear text format in the selected language. The last 50 events are recorded.
Data recording	records operate values
Protection functions	See REX 521 Technical Reference Manual, Standard Configurations (see "Related documents" on page 10).
Control functions	See REX 521 Technical Reference Manual, Standard Configurations (see "Related documents" on page 10).
Condition monitoring functions	See REX 521 Technical Reference Manual, Standard Configurations (see "Related documents" on page 10).
Measurement functions	See REX 521 Technical Reference Manual, Standard Configurations (see "Related documents" on page 10).
Self-supervision	See "Self-supervision" on page 33.
Mechanical dimensions	Width: 148.8 mm (1/3 of a 19" rack) Height, frame: 265.9 mm (6U) Height, box: 249.8 mm Depth: 235 mm For dimension drawings, see Installation Manual (see "Related documents" on page 10).
Weight of the unit	<5 kg

5.2.2. Terminal diagram of REX 521: Basic

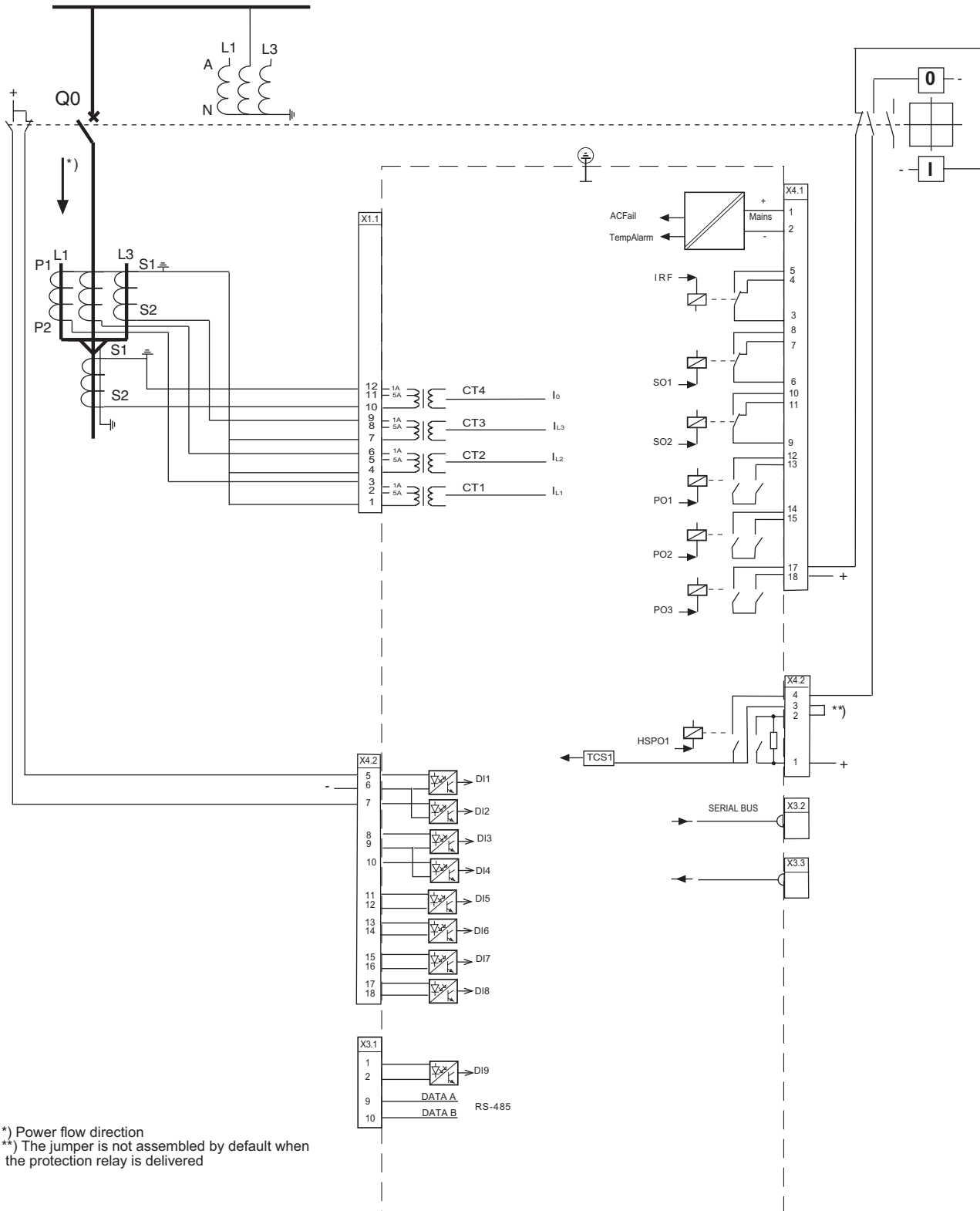

A051916

Fig. 5.2.2.-1 Terminal diagram of REX 521: Basic

5.2.3. Terminal diagram of REX 521: Medium

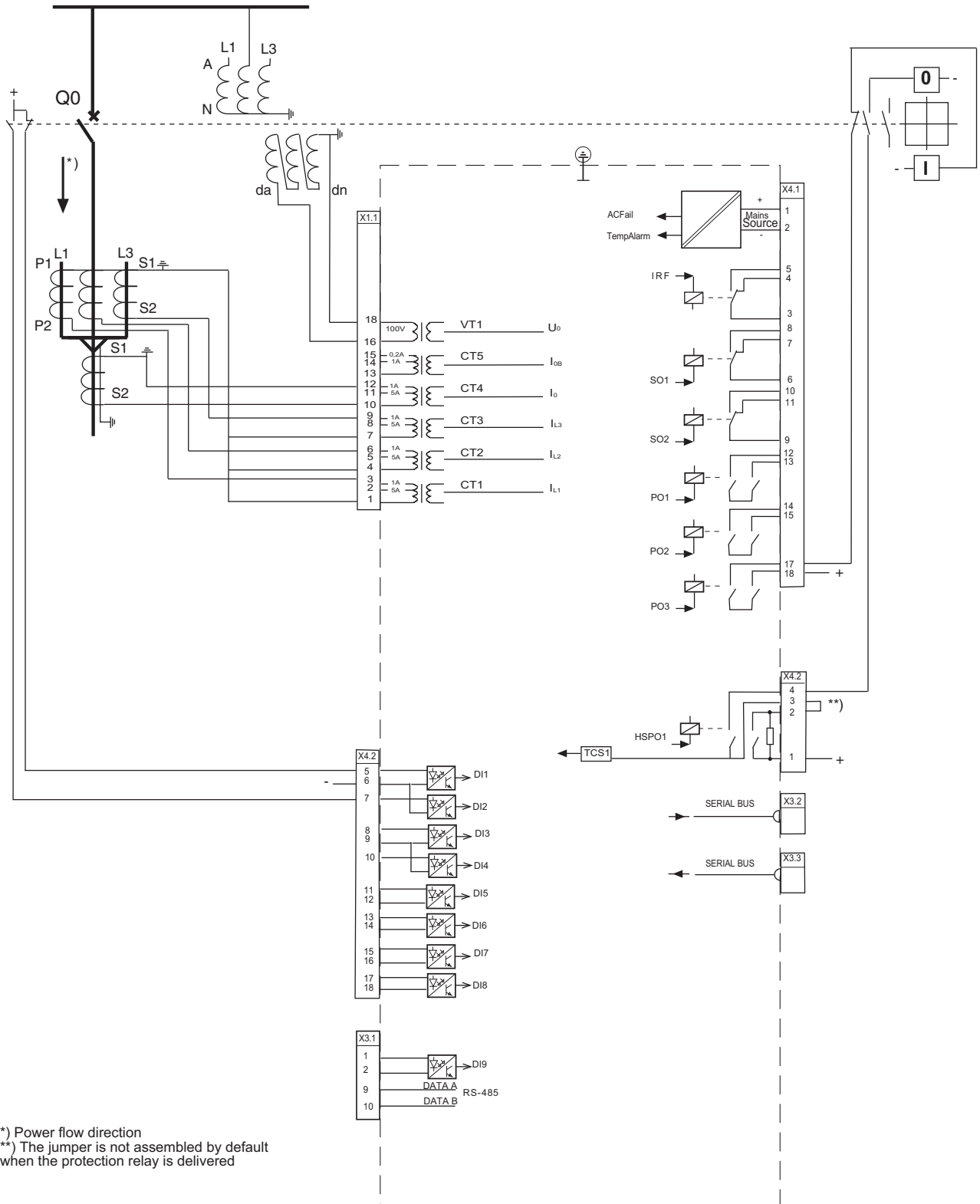

A051917

Fig. 5.2.3.-1 Terminal diagram of REX 521: Medium

5.2.4. Terminal diagram of REX 521: High (excluding H08 and H09)

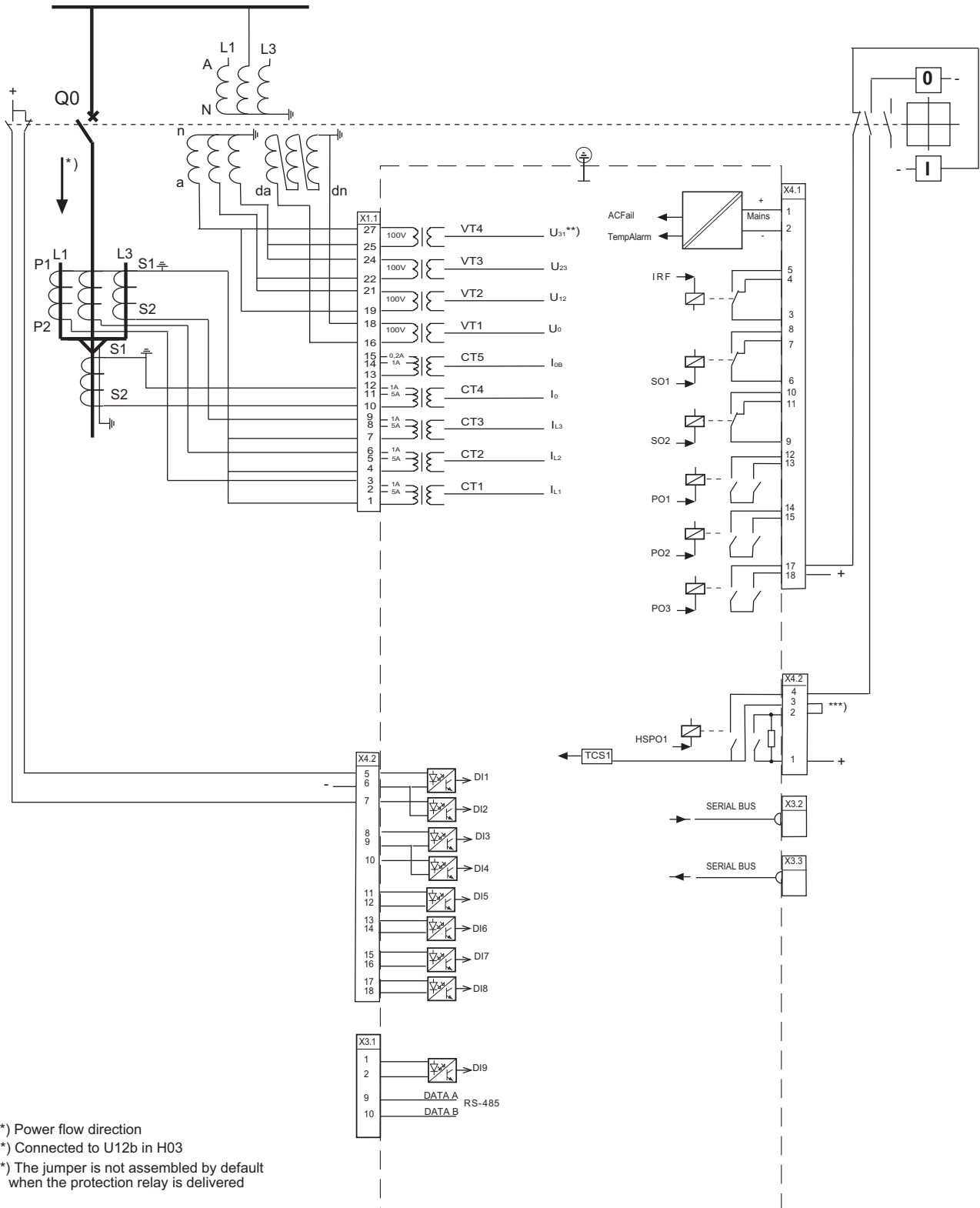

A051918

Fig. 5.2.4.-1 Terminal diagram of REX 521: High (excluding H08 and H09)

5.2.4.1. Terminal diagram of H08 and H09 configurations

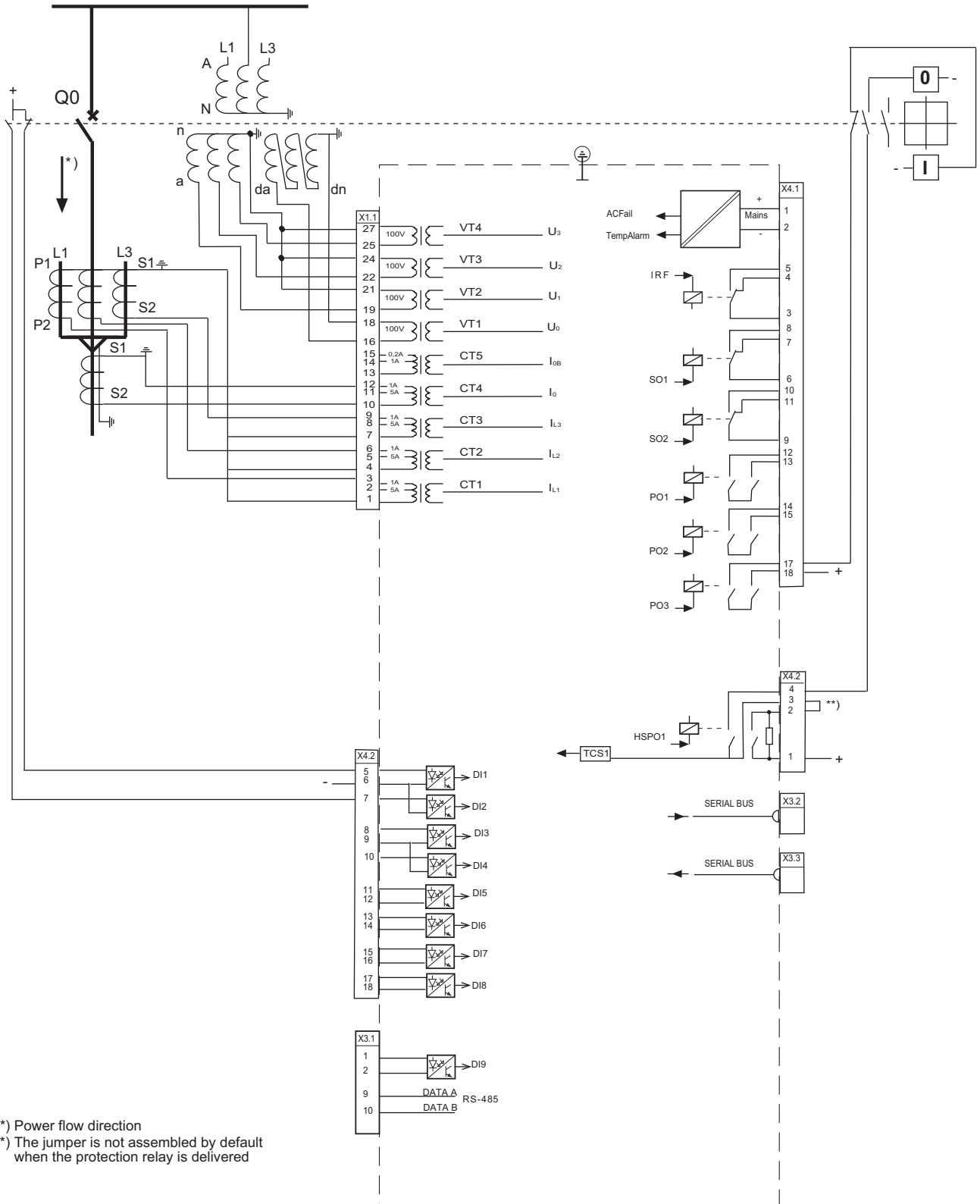

A051919

Fig. 5.2.4.1.-1 Terminal diagram of REX 521: H08/H09 configurations

5.2.5. Terminal diagram of REX 521: Sensor

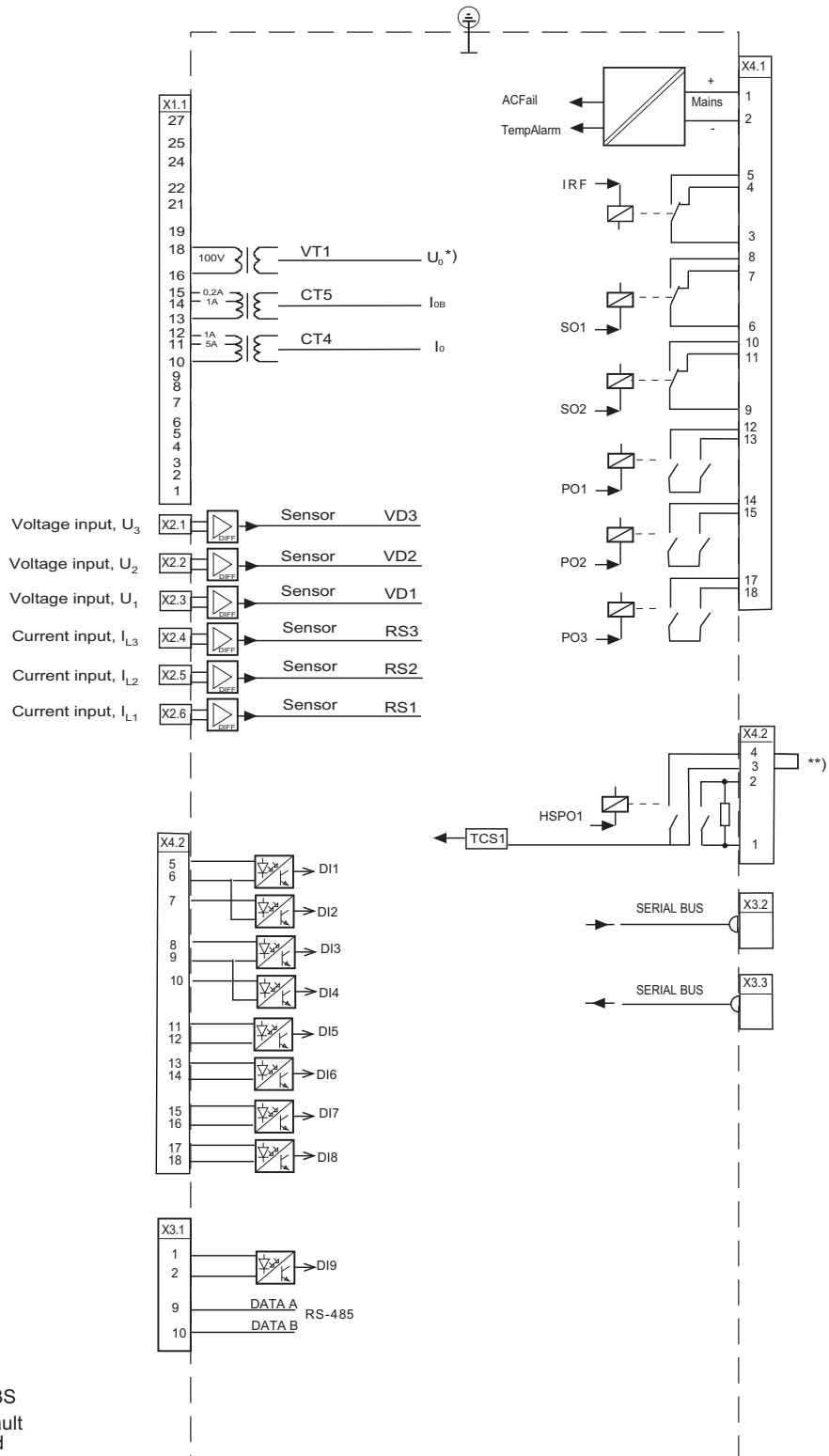

*) Connected to U12b in H01S and H03S

**) The jumper is not assembled by default when the protection relay is delivered

Fig. 5.2.5.-1 Terminal diagram of REX 521: Sensor

5.2.6. Terminal connections

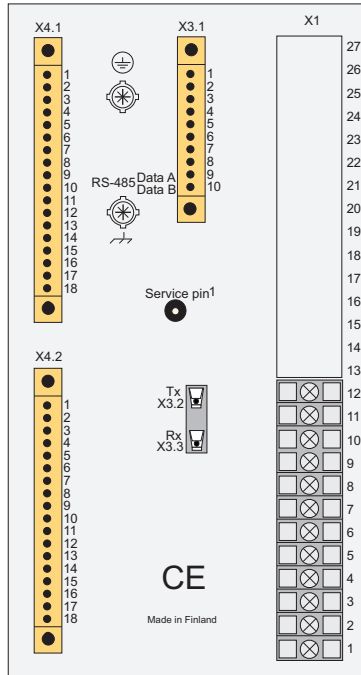

A051921

Fig. 5.2.6.-1 Rear view of REX 521 Basic¹

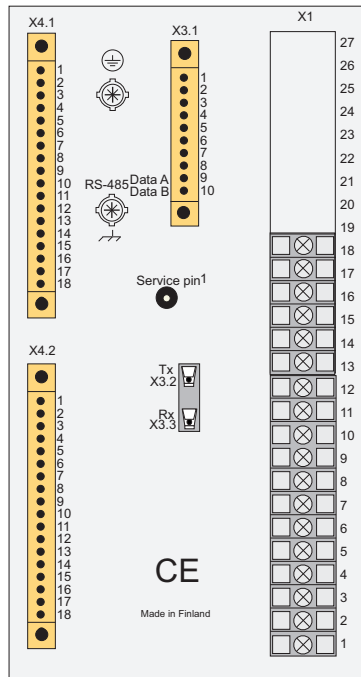

A051922

Fig. 5.2.6.-2 Rear view of REX 521 Medium¹

1. Service Pin is mounted if the HW version contains LON

Technical Reference Manual, General

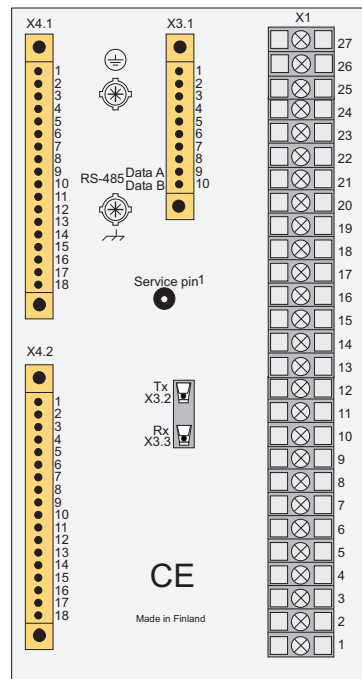

A051923

Fig. 5.2.6.-3 Rear view of REX 521 High¹

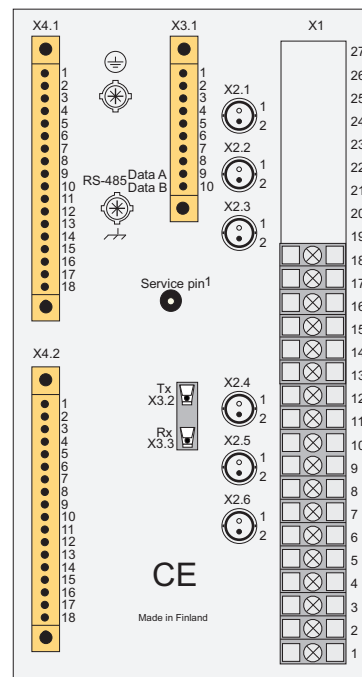

A051924

Fig. 5.2.6.-4 Rear view of REX 521 Sensor¹

1. Service Pin is mounted if the HW version contains LON.

6. Service

When the protection relay is used under the conditions specified in section 5.2.1. Technical data, it is practically maintenance-free. The relay electronics include no parts or components subject to abnormal physical or electrical wear under normal operating conditions.

If the relay fails in operation or if the operating values considerably differ from those mentioned in the relay specifications, the relay should be overhauled. Contact the manufacturer or nearest representative of the manufacturer for further information about checking, overhaul, and recalibration of the relay..



To achieve the best possible operation accuracy, all parts of the protection relay have been calibrated together. In the event of malfunction, please consult your relay supplier.

If the protection relay is sent to the manufacturer, it has to be carefully packed to prevent further damage to the device.

7. Ordering information

When ordering REX 521 protection relays, specify the following:

- Order number
- Quantity
- Additional language
- Optional Chinese front panel (2RCA025000A0001)

Each protection relay has a specific order number that identifies the protection relay type as well as the hardware and the software as described in Fig. 7.-1 below.

The order number is labelled on the marking strip on the front panel of the relay delivered, for example, Order No: REX521GMHPSM01G.

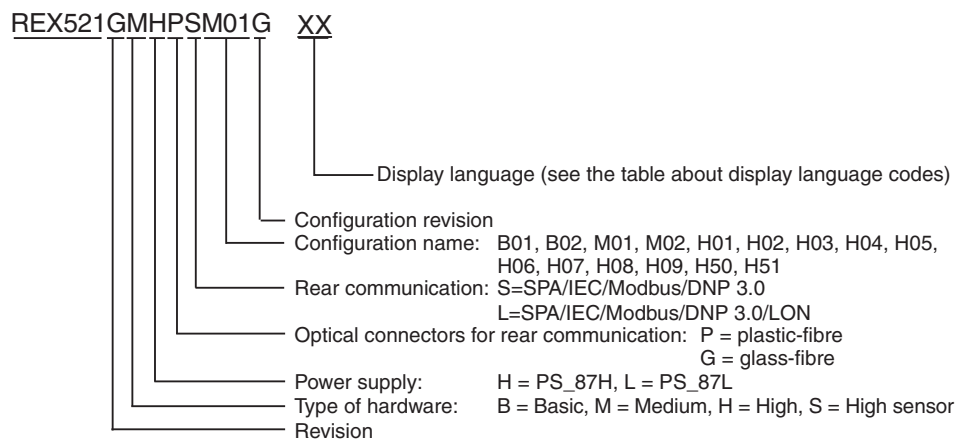

A051925

Fig. 7.-1 Order number of REX 521

English is always available in REX 521. When ordering, the other additional language must be defined according to the following table.

Table 7.-1 Display language codes

Code	Language combination
FI	English-Finnish
SE	English-Swedish
DE	English-German
ES	English-Spanish
FR	English-French
PT	English-Portuguese
PL	English-Polish
ZH	English-Chinese



When Chinese is selected, some of the IEC FB names are translated into Chinese.

When ordering REX 521, the latest hardware and configuration revisions are delivered unless otherwise specified.

8. Revision history of REX 521

8.1. Revision identification

The main releases of REX 521 products are differentiated with the revision and configuration revision letters in the order number (see “Ordering information” on page 61).

Table 8.1.-1 Revisions of REX 521

Product	Revision	Configuration revision	Release
REX 521	A	B	Q3/2001
	B	C	Q3/2002
	C	D	Q4/2003
	E	E	Q2/2004
	G	G	Q1/2006

The revision and configuration revision letters determine the main release which may involve functional additions and changes to the product. Revision letter indicates changes in relay hardware and configuration revision letter in software. The changes included in each release compared to the previous one are described in more detail below.

8.2. Changes and additions to earlier released revision E

General

- New display module
- New language added: Chinese
- Selectable CB closing delay
- Selectable ANSI/IEC symbol support

Function blocks and standard configurations

- Output SWGRP Trip4 and Trip5 added to all configurations
- CB open connectable to PO or a SO
- Blocking of synchro check via digital input possible in configurations H01, H03 and H03S
- New configurations: H09, H50, H51

8.3. Configuration, setting, and SA system tools

The following tool versions are needed to support the new functions and features of Release Q1/2006 revisions of REX 521:

- CAP 501 Relay Configuration Tool; CAP 501 v.2.4.0 or later
- CAP 505 Relay Configuration Tool; CAP 505 v.2.4.0 or later
- LIB 500 Library for MicroSCADA Pro.; LIB 500 v.4.2-1 or later
- LIB 510 Library for MicroSCADA Pro.; LIB 510 v.4.2-1 or later
- SMS 510 v.1.3.0 or later

9. Appendix A: IEC 60870-5-103 bus

9.1. Functions supported by REX 521

Function	Function code	Comment
Reset CU	0	Replies with the identification string
User data	3	<ul style="list-style-type: none"> • GI command • time synchronization (unicast) • application control commands
Broadcast	4	Time synchronization only
Reset FCB	7	Replies with identification string
Request Access Demand	8	
Request Status of Link	9	
Request Class 1 Data	10	
Request Class 2 Data	11	

9.2. General principle of application data mapping

The interface between the REX 521 physical applications and the IEC 60870-5-103 application layer is done accordingly:

Alternative A

If a corresponding REX 521 application signal is defined by the IEC 60870-5-103 standard, the alternative A is used.

Alternative B

Refer to Digitale Stationsletztechnik - Ergänzende Empfehlungen zur Anwendung in Verteilnetzstationen by Vereinigung Deutscher Elektrizitätswerke.

Alternative P

Private definitions are basically used because of two reasons:

1. The standard does not define the signal.
2. The signal is defined by the standard but the REX 521 application signal interface differs from this model.

Class 1 data buffering and priorities

The internal IEC 60870-5-103/Class 1 buffer inside the REX 521 unit can store up to 50 spontaneous events. The interrogation events and the possible response messages, that also are part of the class 1 data, do not occupy space in the buffer. The priority of the different categories of the pending class 1 data is always so that the response messages have the highest priority, thereafter the spontaneous events and finally the interrogation events. The IEC_103 data cannot be filtered by using event masks.

9.3.

Principle of the protection functions mapping

The REX 521 applications, whose modularization is based on trip stages, have been mapped into the IEC 60870-5-103 information numbers according to the following model:

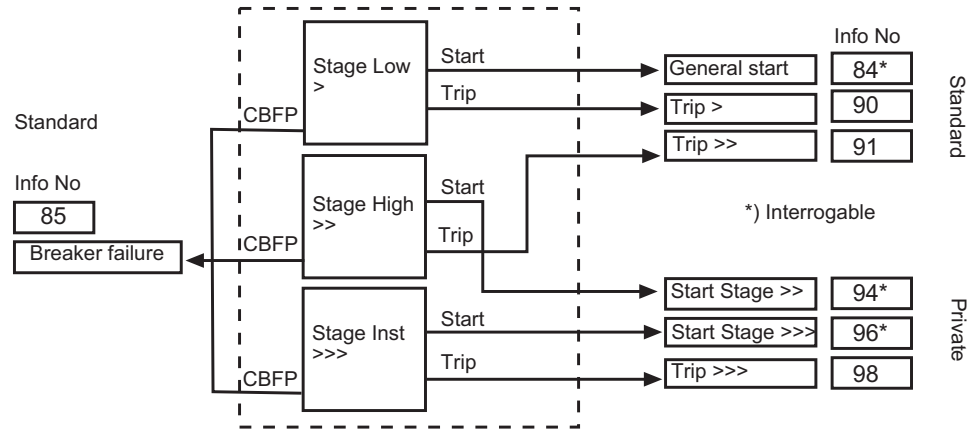

A051926

Fig. 9.3.-1 The principle of the protection functions mapping

The user cannot effect the event flow from the IEC 60870-5-103 protocol by adjusting the event masks of the REX 521 applications.

9.4.

Class 2 data

The measurement (analog) values are transported to the control system as a response to a class 2 request command. The class 2 data is always cyclically updated (COT=2). See Table 9.5.-3 on page 71 for measurement data.

Class 2 measurand sets (ASDU frames)

The IEC 60870-5-103 standard defines the measurands to be transmitted as either Meas I (typeId 3) or Meas II (typeId 9) ASDU frames. According to the standard, the Meas I ASDU can have four different profiles and Meas II has one profile. These five profiles are supported in REX 521. In addition, there are six more private class 2 ASDU frames defined. The user can choose which one of these eleven measurand sets to use. The measurand set number (1...11) can be adjusted via the `Frame type` parameter.

Class 2 value scaling

The IEC 60870-5-103 standard defines the scale (max. range) of the measurements to be either 1.2 or 2.4 times the rated value for the measurement. The selection between the 1.2 scaling or the 2.4 scaling can be done via the `Scale factor` parameter.

In order that the analog (measurement) data becomes available on the IEC 60870-5-103 interface, the measurement applications must have the measurement threshold with a proper threshold value selected.

9.5. Default mappings

Explanations to Table 9.5.-1:

St	Status
A	According to the IEC 60870-5-103 standard
B	According to "Digitale Stationsleittechnik - Erganze Empfehlungen zur Anwendung in Verteilnetzstationen"
P	Private definition
Ftyp	Function type Note! If stated as ^a , the signal type Ftyp corresponds with the unit function type. Unit function type may be adjusted via the <code>Function type</code> parameter.
InfoNum	Information element number
GI	General interrogation 0 = Not in interrogation 1 = Interrogable
Typ	Typeld
COT	Cause of transmission values
1	Spontaneous
9	Interrogated
12	Remote command

Table 9.5.-1 Class 1 data signals

FB name (IEC)	FB name (ANSI)		St	Ftyp	Info Num	GI	Typ	COT	FB name (ABB)
lo>	51N-1	Non-directional earthfault general START	A	160	67	1	2	1, 9	NEF1Low
lo>	51N-1	Non-directional earthfault TRIP>	A	160	92	0	2	1	NEF1Low
lo>>	51N-2	Non-directional earthfault TRIP>>	A	160	93	0	2	1	NEF1High
lo>>	51N-2	Non-directional earthfault START>>	P	162	95	1	1	1, 9	NEF1High
lo>>>	51N-3	Non-directional earthfault START>>>	P	162	97	1	1	1, 9	NEF1Inst
lo>>>	51N-3	Non-directional earthfault TRIP>>>	P	162	99	0	1	1	NEF1Inst
lo>-->	67N-1	Directional earthfault general START	P	163	67	1	1	1, 9	DEF2Low
lo>-->	67N-1	Directional earthfault TRIP>	P	163	92	0	1	1	DEF2Low
lo>>-->	67N-2	Directional earthfault TRIP>>	P	163	93	0	1	1	DEF2High
lo>>-->	67N-2	Directional earthfault START>>	P	163	95	1	1	1, 9	DEF2High
lo>>>-->	67N-3	Directional earthfault START>>>	P	163	97	1	1	1, 9	DEF2Inst
lo>>>-->	67N-3	Directional earthfault TRIP>>>	P	163	99	0	1	1	DEF2Inst
I2>	46-1	Negative-phase-sequence protection general START	P	21	84	1	1	1,9	NPS3Low
I2>	46-1	Negative-phase-sequence protection TRIP>	P	21	90	0	1	1	NPS3Low
I2>>	46-2	Negative-phase-sequence protection START>>	P	21	91	1	1	1,9	NPS3High
I2>>	46-2	Negative-phase-sequence protection TRIP>>	P	21	94	0	1	1	NPS3High
3I()	46R	Phase reversal protection START	P	22	84	1	1	1,9	PREV3
3I()	46R	Phase reversal protection TRIP	P	22	90	0	1	1	PREV3
3I<	37-1	Non-directional undercurrent, St1, START	P	20	84	1	1	1,9	NUC3St1
3I<	37-1	Non-directional undercurrent, St1, TRIP	P	20	90	0	1	1	NUC3St1
3I>	51-1	Non-directional overcurrent general START	A	160	84	1	2	1, 9	NOC3Low
3I>	51-1	Non-directional overcurrent TRIP>	A	160	90	0	2	1	NOC3Low
3I>>	51-2	Non-directional overcurrent TRIP>>	A	160	91	0	2	1	NOC3High
3I>>	51-2	Non-directional overcurrent START>>	P	162	94	1	1	1, 9	NOC3High
3I>>>	51-3	Non-directional overcurrent START>>>	P	162	96	1	1	1, 9	NOC3Inst

Technical Reference Manual, General

Table 9.5.-1 Class 1 data signals (Continued)

FB name (IEC)	FB name (ANSI)		St	Ftyp	Info Num	GI	Typ	COT	FB name (ABB)
3I>>>	51-3	Non-directional overcurrent TRIP>>>	P	162	98	0	1	1	NOC3Inst
3I>->	67-1	Directional overcurrent general START	P	164	84	1	1	1, 9	DOC6Low
3I>->	67-1	Directional overcurrent TRIP>	P	164	90	0	1	1	DOC6Low
3I>>->	67-2	Directional overcurrent START>>	P	164	94	1	1	1, 9	DOC6High
3I>>->	67-2	Directional overcurrent TRIP>>	P	164	91	0	1	1	DOC6High
3I2f>	68	Inrush START	P	167	84	1	1	1, 9	Inrush3
Is2t,n<	48	Start-up supervision for motors START	P	178	84	1	1	1,9	MotStart
Is2t,n<	48	Start-up supervision for motors TRIP	P	178	90	0	1	1	MotStart
Is2t,n<	48	Start-up supervision for motors STALL	P	178	85	0	1	1	MotStart
3Ith>	49F	Thermal overload (cables) START	P	168	84	1	1	1, 9	TOL3Cab
3Ith>	49F	Thermal overload (cables) TRIP>	P	168	90	0	1	1	TOL3Cab
3Ith>	49F	Thermal overload (cables), Current alarm	P	168	91	0	1	1	TOL3Cab
3Ithdev>	49M/G/T	Thermal overload protection (devices) START	P	184	84	1	1	1,9	TOL3Dev
3Ithdev>	49M/G/T	Thermal overload protection (devices) TRIP	P	184	90	0	1	1	TOL3Dev
Iub>	46	Current unbalance START	P	173	84	1	1	1, 9	CUB3Low
Iub>	46	Current unbalance TRIP>	P	173	90	0	1	1	CUB3Low
		Master trip signal	P	10	221	0	1	1	system
		External trip signal	P	10	222	0	1	1	system
		Lockout	P	10	223	0	1	1	system
		Breaker failure	A	a	85	0	1	1	b
0-->I	79	AR sequence successful	A	a	128	0	1	1	AR5Func
0-->I	79	AR interrupted	A	a	130	0	1	1	AR5Func
0-->I	79	AR in use/ not in use	A	a	16	1	1	1, 9	AR5Func
0-->I	79	AR: change in CB position	B	240	180	0	1	1	AR5Func
0-->I	79	AR shot1	P	169	101	0	1	1	AR5Func
0-->I	79	AR shot 2	P	169	102	0	1	1	AR5Func
0-->I	79	AR shot 3	P	169	103	0	1	1	AR5Func
0-->I	79	AR shot 4	P	169	104	0	1	1	AR5Func
0-->I	79	AR shot 5	P	169	105	0	1	1	AR5Func
0-->I	79	AR shot 1 successful	P	169	111	0	1	1	AR5Func
0-->I	79	AR shot 2 successful	P	169	112	0	1	1	AR5Func
0-->I	79	AR shot 3 successful	P	169	113	0	1	1	AR5Func
0-->I	79	AR shot 4 successful	P	169	114	0	1	1	AR5Func
0-->I	79	AR shot 5 successful	P	169	115	0	1	1	AR5Func
0-->I	79	AR sequence	P	169	120	0	1	1	AR5Func
0-->I	79	AR: final trip	P	169	121	0	1	1	AR5Func
0-->I	79	AR: def. trip alarm	P	169	150	0	1	1	AR5Func
0-->I	79	AR: CB opened manually or remotely	P	169	160	0	1	1	AR5Func
0-->I	79	AR: CB operation failure	P	169	161	0	1	1	AR5Func
0-->I	79	AR: closing inhibited	P	169	162	0	1	1	AR5Func
0-->I	79	AR: lockout	P	169	164	1	1	1, 9	AR5Func
I<->0	79	CB1: breaker 1 position ^c	B	240	160	1	1	1, 9	COCB1
I<->0	79	IND1: disconnecter 1	B	240	161	1	1	1, 9	COIND1
I<->0	79	IND2: earthswitch	B	240	164	1	1	1, 9	COIND2
I<->0	79	IND3: motor status indication	P	240	165	1	1	1,9	COIND3
I<->0	79	CB1: command sequence	P	242	201	0	1	1	COCB1
I<->0	79	CB1: open output	P	242	202	0	1	1	COCB1
I<->0	79	CB1: close output	P	242	203	0	1	1	COCB1
I<->0	79	CB1: opening time	P	242	204	0	1	1	COCB1

Technical Reference Manual, General

Table 9.5.-1 Class 1 data signals (Continued)

FB name (IEC)	FB name (ANSI)		St	Ftyp	Info Num	GI	Typ	COT	FB name (ABB)
I<->0	79	CB1: closing time	P	242	205	0	1	1	COCB1
I<->0	79	CB1: command status	P	242	206	0	1	1	COCB1
		Control position (local/remote)	P	250	220	1	1	1, 9	system
		Auxiliary input 1 (Digital input 6)	A	a	27	1	1	1, 9	system
		Auxiliary input 2 (Digital input 7)	A	a	28	1	1	1, 9	system
		Auxiliary input 3 (Digital input 8)	A	a	29	1	1	1, 9	system
		Auxiliary input 4 (Digital input 9)	A	a	30	1	1	1, 9	system
		Auxiliary input 5 (Digital input 1)	P	249	231	1	1	1, 9	system
		Auxiliary input 6 (Digital input 2)	P	249	232	1	1	1, 9	system
		Auxiliary input 7 (Digital input 3)	P	249	233	1	1	1, 9	system
		Auxiliary input 8 (Digital input 4)	P	249	234	1	1	1, 9	system
		Auxiliary input 9 (Digital input 5)	P	249	235	1	1	1, 9	system
		Output relay 1 position (HSPO1)	P	251	27	1	1	1, 9	system
		Output relay 2 position (PO1)	P	251	28	1	1	1, 9	system
		Output relay 3 position (PO2)	P	251	29	1	1	1, 9	system
		Output relay 4 position (PO3)	P	251	30	1	1	1, 9	system
		Output relay 5 position (SO1)	P	251	31	1	1	1, 9	system
		Output relay 6 position (SO2)	P	251	32	1	1	1, 9	system
		Test mode ON/OFF	P	10	21	1	1	1, 9	system
DREC	DREC	Recorder full memory	P	195	50	0	1	1	MEDREC16
DREC	DREC	Recorder triggered	P	195	51	0	1	1	MEDREC16
CB wear1	CB wear1	CB1 wear alarm	P	194	10	0	1	1	CMBWEAR1
MCS 3I	MCS 3I	Current input circuit supervision	A	a	32	1	1	1, 9	CMCU
MCS 3U	MCS 3U	Voltage input circuit supervision	A	a	33	1	1	1, 9	CMVO
TCS1	TCS1	Trip-circuit supervision	A	a	36	1	1	1, 9	CMTCS1
Uo>	59N-1	Residual overvoltage general START	P	170	84	1	1	1, 9	ROV1Low
Uo>	59N-1	Residual overvoltage TRIP>	P	170	90	0	1	1	ROV1Low
Uo>>	59N-2	Residual overvoltage START>>	P	170	94	1	1	1, 9	ROV1High
Uo>>	59N-2	Residual overvoltage TRIP>>	P	170	91	0	1	1	ROV1High
Uo>>>	59N-3	Residual overvoltage START>>>	P	170	96	1	1	1, 9	ROV1Inst
Uo>>>	59N-3	Residual overvoltage TRIP>>>	P	170	98	0	1	1	ROV1Inst
U1U2<>_1	47-1	Phase sequency voltage protection, St1, START U2>	P	179	1	1	1	1, 9	PSV3St1
U1U2<>_1	47-1	Phase sequency voltage protection, St1, START U1<	P	179	2	1	1	1, 9	PSV3St1
U1U2<>_1	47-1	Phase sequency voltage protection, St1, START U1>	P	179	3	1	1	1, 9	PSV3St1
U1U2<>_1	47-1	Phase sequency voltage protection, St1, TRIP U2>	P	179	4	0	1	1	PSV3St1
U1U2<>_1	47-1	Phase sequency voltage protection, St1, TRIP U1<	P	179	5	0	1	1	PSV3St1
U1U2<>_1	47-1	Phase sequency voltage protection, St1, TRIP U1>	P	179	6	0	1	1	PSV3St1
3U>	59-1	Overvoltage general START	P	165	84	1	1	1, 9	OV3Low
3U>	59-1	Overvoltage TRIP>	P	165	90	0	1	1	OV3Low
3U>>	59-2	Overvoltage START>>	P	165	94	1	1	1, 9	OV3High
3U>>	59-2	Overvoltage TRIP>>	P	165	91	0	1	1	OV3High
3U<	27-1	Undervoltage general START	P	166	84	1	1	1, 9	UV3Low
3U<	27-1	Undervoltage TRIP<	P	166	90	0	1	1	UV3Low
3U<<	27-2	Undervoltage START<<	P	166	94	1	1	1, 9	UV3High
3U<<	27-2	Undervoltage TRIP<<	P	166	91	0	1	1	UV3High
SYNC1	25-1	Synchro-check/voltage check, St 1, SC Due	P	218	1	1	1	1, 9	SCVCSt1
SYNC1	25-1	Synchro-check/voltage check, St 1, SC Ok	P	218	2	1	1	1, 9	SCVCSt1
SYNC1	25-1	Synchro-check/voltage check, St 1, Alarm not passed	P	218	3	1	1	1, 9	SCVCSt1
f1	81-1	Underfrequency or overfrequency, St1, START1	P	171	84	1	1	1, 9	Freq1St1

Table 9.5.-1 Class 1 data signals (Continued)

FB name (IEC)	FB name (ANSI)		St	Ftyp	Info Num	GI	Typ	COT	FB name (ABB)
f1	81-1	Underfrequency or overfrequency, St1, TRIP1	P	171	90	0	1	1	Freq1St1
f1	81-1	Underfrequency or overfrequency, St1, START2	P	171	94	1	1	1,9	Freq1St1
f1	81-1	Underfrequency or overfrequency, St1, TRIP2	P	171	91	0	1	1	Freq1St1
f2	81-2	Underfrequency or overfrequency, St2, START1	P	172	84	1	1	1,9	Freq1St2
f2	81-2	Underfrequency or overfrequency, St2, TRIP1	P	172	90	0	1	1	Freq1St2
f2	81-2	Underfrequency or overfrequency, St2, START2	P	172	94	1	1	1,9	Freq1St2
f2	81-2	Underfrequency or overfrequency, St2, TRIP2	P	172	91	0	1	1	Freq1St2
PQ 3Inf	PQ 3Inf	Current harmonic limit	P	204	20	0	1	1	PQCU3H
PQ 3Unf	PQ 3Unf	Voltage waveform distortion measurement	P	205	20	0	1	1	PQVO3H
ALARM1	ALARM1	ALARM1 status	P	253	88	1	1	1,9	MMIALAR1
ALARM2	ALARM2	ALARM2 status	P	253	89	1	1	1,9	MMIALAR2
ALARM3	ALARM3	ALARM3 status	P	253	90	1	1	1,9	MMIALAR3
ALARM4	ALARM4	ALARM4 status	P	253	91	1	1	1,9	MMIALAR4
ALARM5	ALARM5	ALARM5 status	P	253	92	1	1	1,9	MMIALAR5
ALARM6	ALARM6	ALARM6 status	P	253	93	1	1	1,9	MMIALAR6
ALARM7	ALARM7	ALARM7 status	P	253	94	1	1	1,9	MMIALAR7
ALARM8	ALARM8	ALARM8 status	P	253	95	1	1	1,9	MMIALAR8
TIME1	TIME1	Accumulated time 1 alarm	P	238	12	1	1	1,9	CMTIME1
TIME1	TIME1	Accumulated time 1 measurement	P	238	11	1	1	1,9	CMTIME1
FUSEF	60	Fuse failure	P	253	83	1	1	1,9	FUSEFAIL
		AC fail	P	240	181	1	1	1,9	system
		IRF test	P	239	11	0	1	1	system
		IRF error	P	239	12	1	1	1,9	system
		Local parameter setting done	P	10	22	0	1	1	system

- a. The signal type Ftyp corresponds with the unit function type. Unit function type may be adjusted via the Function type parameter
- b. Breaker failure is generated by all the protection functions
- c. Also DPI values 0 (Middle) and 3 (Faulty) are transferred

Commands

Explanations to Table 9.5.-2:

St	Status
A	According to the IEC 60870-5-103 standard
B	According to "Digitale Stationsleittechnik - Erganze Empfehlungen zur Anwendung in Verteilnetzstationen"
P	Private definition
Ftyp	Function type Note! If stated as ^a , the signal type Ftyp corresponds with the unit function type. Unit function type may be adjusted via the Function type parameter.
InfoNum	Information element number
COT cmd	Cause of transmission values in command direction
20	General command
COT resp	Cause of transmission values in response direction
20	Positive acknowledgement
21	Negative acknowledgement

Table 9.5.-2 Commands

Commands		St	Ftyp	Info Num	Typ	COT cmd	COT resp
I<->0	CB1: control CB1	B	240	160	20	20	20,21
	Output relay 1 control (HSPO1)	P	251	27	20	20	20,21
	Output relay 2 control (PO1)	P	251	28	20	20	20,21
	Output relay 3 control (PO2)	P	251	29	20	20	20,21
	Output relay 4 control (PO3)	P	251	30	20	20	20,21
	Output relay 5 control (SO1)	P	251	31	20	20	20,21
	Output relay 6 control (SO2)	P	251	32	20	20	20,21



When controlling the output relays by using the IEC_103 protocol, the interlocking of the standard configuration is bypassed. It is not allowed to use the same output relay as a tripping contact and as an IEC_103 controlling object simultaneously.

Class 2 measurand sets

Explanations to Table 9.5.-3:

SetNo	Class 2 measurand set No (1...11)
St	Status
A	According to the IEC 60870-5-103 standard
P	Private definition
Meas	Measurand class I or II
FuncType/ InfoNum	Class 2 Frame identification Note! If stated as ^a , the signal type Ftyp corresponds with the unit function type. Unit function type may be adjusted via the <code>Function type</code> parameter.
Num data	The number of the data values in the class 2 message data part
Typ	Meas type 3 or 9 (when the definition is private, meas type 9 is used)
Data	Measurement data in class 2 message data part: Not available: -

The measurand sets 2, 3, 5, 6, 7, 8 and 9 are not relevant for the Basic and Medium versions of the protection relay. The default measurand set is 11.

Table 9.5.-3 Recommended Class 2 measurand sets

Set No		St	Meas	Func Type	Info Num	Num data	Typ	Data
1	Meas I: 144	A	I	a	144	1	3	IL2
2	Meas I: 145	A	I	a	145	2	3	IL2, U12
3	Meas I: 146	A	I	a	146	4	3	IL1, U12, P, Q
4	Meas I: 147	A	I	a	147	2	3	Io, Uo
5	Meas II: 148	A	II	a	148	9	9	IL1, IL2, IL3, U1, U2, U3, P, Q, f
6	Meas II: ABB1	P	II	134	137	16	9	IL1, IL2, IL3, Io, -, -, -, U12, U23, U31, P, Q, f, -, -, pf
7	Meas II: ABB2	P	II	134	137	16	9	IL1, IL2, IL3, Io, U1, U2, U3, -, -, -, P, Q, f, -, -, pf
8	Meas II: ABB3	P	II	135	137	12	9	IL1, IL2, IL3, U1, U2, U3, Io, Uo, P, Q, pf, f
9	Meas II: ABB4	P	II	135	138	12	9	IL1, IL2, IL3, U12, U23, U31, Io, Uo, P, Q, pf, f
10	Meas II: Basic	P	II	135	139	4	9	IL1, IL2, IL3, Io
11	Meas II: Medium	P	II	135	140	5	9	IL1, IL2, IL3, Io, Uo

a. According to the device function type

Example

If set No 11 is used, the ASDU octets will look like in the following table:

9	Typeld
5	VSQ=Number of data
COT	
ADR	
135	Function type
140	Information number
IL1	Data1
IL2	Data2
IL3	Data3
Io	Data4
Uo	Data5

10. Appendix B: Parameters visible only in the relay

Input 1 state	
Input 2 state	
Input 3 state	
Input 4 state	
Input 5 state	
Input 6 state	
Input 7 state	
Input 8 state	
Input 9 state	
Input states	
Output states	
Test mode	
Activate IRF	
Software reset	
Factory settings	
Send Neuron ID	
Load def config.	
Password HMI	
Date	
Time	
SPA address	SPA front
Baud rate	SPA front
Slave status	SPA front
SPA address	SPA rear
Baud rate	SPA rear
Slave status	SPA rear
Local/Remote	
Alarm LED states	
No of stop bits	Modbus
End of frame TO	Modbus
No of data bits	Modbus
Avoidance count	DNP
Bay name	

11. Appendix C: Parameters which cause reset

Rated frequency	
Select Io	
Voltage combine	
IL1: scaling	
IL2: scaling	
IL3: scaling	
Io: scaling	
Iob: scaling	
Uo: scaling	
U1: scaling	
U2: scaling	
U3: scaling	
U12: scaling	
U23: scaling	
U31: scaling	
U12b: scaling	
Second. current	Current trafo 1
Primary current	Current trafo 1
Current terminal	Current trafo 1
Corr. factor 1	Current trafo 1
Displ. error 1	Current trafo 1
Corr. factor 2	Current trafo 1
Displ. error 2	Current trafo 1
Second. current	Current trafo 2
Primary current	Current trafo 2
Current terminal	Current trafo 2
Corr. factor 1	Current trafo 2
Displ. error 1	Current trafo 2
Corr. factor 2	Current trafo 2
Displ. error 2	Current trafo 2
Second. current	Current trafo 3
Primary current	Current trafo 3
Current terminal	Current trafo 3
Corr. factor 1	Current trafo 3
Displ. error 1	Current trafo 3
Corr. factor 2	Current trafo 3
Displ. error 2	Current trafo 3
Second. current	Current trafo 4
Primary current	Current trafo 4
Current terminal	Current trafo 4
Corr. factor 1	Current trafo 4
Displ. error 1	Current trafo 4
Corr. factor 2	Current trafo 4
Displ. error 2	Current trafo 4
Second. current	Current trafo 5
Primary current	Current trafo 5
Current terminal	Current trafo 5

Technical Reference Manual, General

Corr. factor 1	Current trafo 5
Displ. error 1	Current trafo 5
Corr. factor 2	Current trafo 5
Displ. error 2	Current trafo 5
Second. voltage	Voltage trafo 1
Primary voltage	Voltage trafo 1
Corr. factor	Voltage trafo 1
Displ. error	Voltage trafo 1
Second. voltage	Voltage trafo 2
Primary voltage	Voltage trafo 2
Corr. factor	Voltage trafo 2
Displ. error	Voltage trafo 2
Second. voltage	Voltage trafo 3
Primary voltage	Voltage trafo 3
Corr. factor	Voltage trafo 3
Displ. error	Voltage trafo 3
Second. voltage	Voltage trafo 4
Primary voltage	Voltage trafo 4
Corr. factor	Voltage trafo 4
Displ. error	Voltage trafo 4
Output voltage	Rog. sensor 1
Rated current	Rog. sensor 1
Corr. factor	Rog. sensor 1
Displ. error	Rog. sensor 1
Output voltage	Rog. sensor 2
Rated current	Rog. sensor 2
Corr. factor	Rog. sensor 2
Displ. error	Rog. sensor 2
Output voltage	Rog. sensor 3
Rated current	Rog. sensor 3
Corr. factor	Rog. sensor 3
Displ. error	Rog. sensor 3
Division ratio	Volt. divider 1
Primary voltage	Volt. divider 1
Corr. factor	Volt. divider 1
Displ. error	Volt. divider 1
Division ratio	Volt. divider 2
Primary voltage	Volt. divider 2
Corr. factor	Volt. divider 2
Displ. error	Volt. divider 2
Division ratio	Volt. divider 3
Primary voltage	Volt. divider 3
Corr. factor	Volt. divider 3
Displ. error	Volt. divider 3

12.**Appendix D: Parameters which require test mode**

Input 1 state
Input 2 state
Input 3 state
Input 4 state
Input 5 state
Input 6 state
Input 7 state
Input 8 state
Input 9 state
Input states
Output states
Activate IRF

13. Abbreviations

ASCII	American Standard Code for Information Interchange
CRC	Cyclic redundancy check
CT	Current transformer
DI	Digital input
HMI	Human-machine interface
HSPO	High-speed power output
IRF	Internal relay fault
LCD	Liquid crystal display
MMI	Man-machine interface
NC	Normally closed
NO	Normally open
PO	Power output
RS	Rogowski sensor
RTC	Real-time clock
RTU	Remote terminal unit
SA	Substation automation
SO	Signalling output
TCS	Trip-circuit supervision
VD	Voltage divider
VT	Voltage transformer

14.**Index**

A	
Alarm LEDs	45
Activating	46
Clearing a certain LED	46
Reading actual state	46
Testing	46
Alarms	
Acknowledging	45
Clearing, <i>see</i> Acknowledging	
Enabling	45
Analogue channels	24
Auxiliary power supplies	48
Auxiliary voltage	22, 23, 48
Auxiliary voltage indication	23
Auxiliary voltage supply	22
C	
Communication	50
Correction parameters and factors	26
Current sensor, <i>see</i> Rogowski coil	
Current transformer values	25
D	
Digital inputs	27, 48
Filtering	27
Inversion	28
Testing	30
Voltage range	23
Display language	61
Display panel	45
E	
Electromagnetic compatibility tests	49
Energizing inputs	48
Environmental conditions	49
F	
Fault indication	34
Fault indications	35
Actions	35
Codes	35
G	
Graphical I/O Setting Tool	20

H	
Hardware versions	16
HMI	45
I	
Internal power supply	22
Internal relay fault	33
IRF output	34
IRF, <i>see</i> Internal relay fault	
Isolated RS-485 connection	36, 37
L	
labels	46
LED label	46
M	
Measuring devices	
Technical data	25
Modbus	36
N	
Non-volatile memory	22
O	
Optical RS-232 interface	41
Order number	24
Ordering REX 521 protection relays	61
Outputs	28
High-speed power output	28
Signalling relay outputs	30
Single-pole power outputs	29
Testing	30
Overtemperature indication	23
P	
Parameterization	19
Power outputs	49
Power supply modules	23
Protocols	
DNP 3.0	36, 42
IEC 60870-5-103	36, 40, 44, 65
IEC 61850	43
LON	36, 37, 39, 44
Modbus	41
Profibus	43
SPA	36, 37, 39, 44, 73

R	
Rated values	24
Real-time clock	22
Rear port options	37
Relay parameters	73
Relay Setting Tool	19
Requirements	17
Restoring factory settings	21
Revisions	63
REX 521 protection relay	
Application area	14
General information	13
Rogowski coil	24, 26
Rogowski coil values	25
RS-232 interface	41
RS-485 two-wire interface	41
S	
Scaling factors	24
Self-supervision	33
Functions	33
Self-supervision signal	34
Sensor	16, 24, 48
Serial communication	36, 37, 50
Serial communication ports	
Front panel optical PC connection	37
RS-485 connection	37
Service	59
Service pin	37
Signal outputs	48
T	
Temperature supervision	23
Terminal connections	57
Terminal diagrams	
Basic	52
High	54
High, Configuration H08, H09	55
Medium	53
Sensor	56
Tests	49
Time synchronization	44
Trip-circuit supervision	31, 49
External resistor values	32
External shunt resistance	31

Technical Reference Manual, General

V

Voltage divider values	26
Voltage transformer values	25



ABB Oy

Distribution Automation

P.O. Box 699

FI-65101 Vaasa

FINLAND

Tel. +358 10 22 11

Fax. +358 10 224 1094

www.abb.com/substationautomation