

UNITROL® 6000 Excitation systems

Setting the standard in technology and availability



- Industry benchmark in availability
- Ultimate control performance keeps synchronous machine within safe limits
- Guaranteed grid code compliance through advanced PSS options, validated models and simulation services
- Hardware in the Loop simulator, to expedite tuning and site-testing
- Simple system operation, monitoring, and maintenance
- Pro-active life cycle management throughout the complete life-span of the equipment
- 24/7/365 technical support always within your reach, utilizing remote access platforms

Setting the standard

ABB UNITROL® excitation systems are a key component in many power generating units used by plant owners and operators to achieve reliability of operations, stability, and fast transient response of their assets, as per grid requirements.

The UNITROL® 6000 excitation systems series is specifically designed to serve a wide range of applications:

- Generators: steam, gas, nuclear and hydro power plants, nuclear emergency diesel
- Motors: steel mills, pulp and paper, chemical, natural gas production plants, refineries

UNITROL® 6000 for indirect and static excitation systems comes in the following versions:

- UNITROL® 6000 Medium
- UNITROL® 6000 X-power

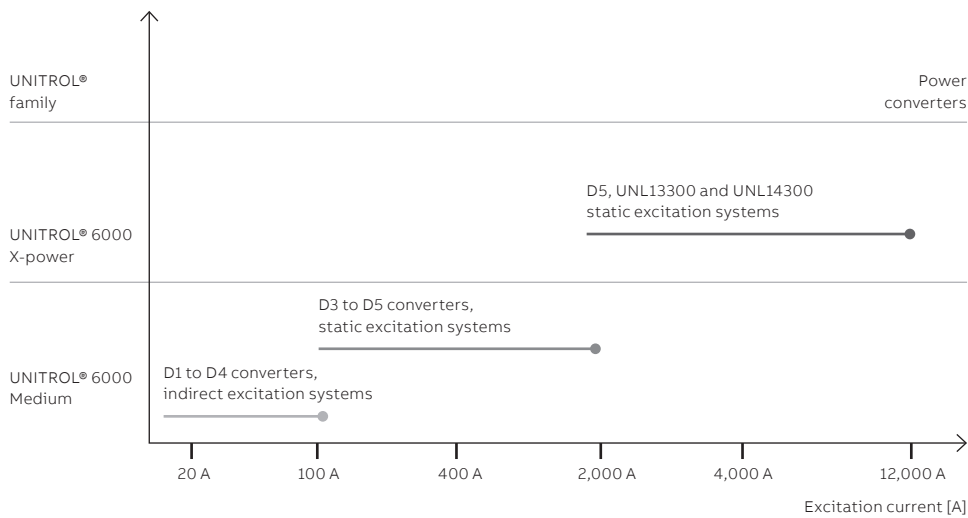

UNITROL® 6000 Medium

The customizable solution

UNITROL® 6000 Medium is designed for small to medium static excitation systems. It is as well a benchmark in flexibility, reliability and connectivity for brushless and critical steam generating units.

With single/double channel configuration (additional backup channel on request) and a wide selection of thyristor bridge modules, UNITROL® 6000 Medium can be configured to meet all field data and availability requirements.

Selected applications

- Hydro power plant
- Pumped storage power plant
- Combined cycle power plant
- Critical Steam power plant with brushless excitation, Ifn 200 A, 400 Hz supply

Engineered solutions:

- Online supply transfer
- Electric braking

Main Features	UNITROL® 6000 Medium
Customizable	Yes
DC current range	<1,800 A
Backup channel	Yes / Optional
Converter redundancy	Single, twin, twin + backup
Max. converters	3
H configuration	No
Converter types	D1, D2, D3, D4, D5
PSS	2B/2C
APSS	No
PEC controller generation	2
IEC 61850	Optional
Field breaker	AC or DC

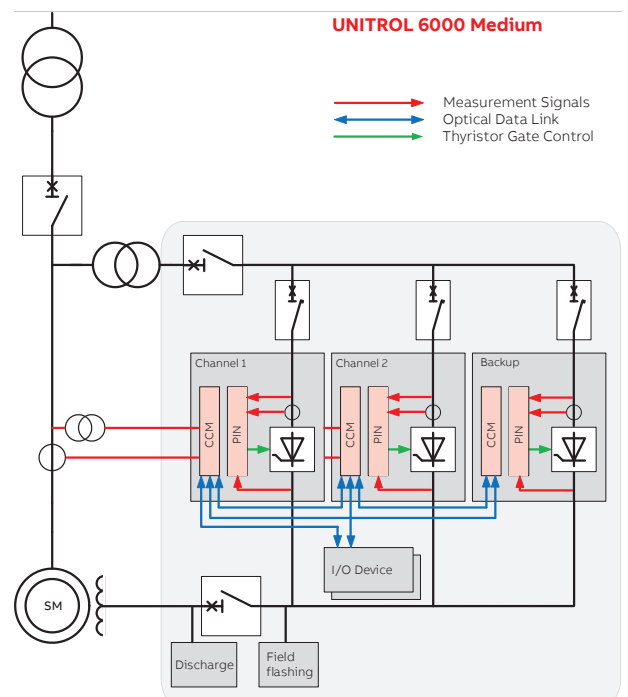

UNITROL® 6000 X-power

The solution for large power applications

UNITROL® 6000 X-power is designed for large power generation units and brings a new benchmark in flexibility, reliability and connectivity.

With single/double channel control configuration (additional backup controller on request) and a wide selection of thyristor bridge modules, UNITROL® 6000 X-power can be configured to meet all field data and availability requirements.

Selected applications

- Nuclear power plant, field current $I_{fn} > 10,000$ A
- Underground hydro power plant, $I_{fn} 4,500$ A, with redundant air-to-water heat exchanger system
- Gas turbine power plant, MEGATROL package with $I_{fn} 6,000$ A and static frequency converter 15 MW for turbine starting
- Coal-fired power plant, $I_{fn} 3,500$ A, power part in IP54 container, detached AVR cabinet with > 150 m distance apart
- Hydro power plant, $I_{fn} 4,000$ A, two DC field circuit breakers, one for DC backup excitation

Main Features	UNITROL® 6000 X-power
Customizable	Yes
DC current range	1,800 A < X < 12,000 A
Backup channel	Yes / Optional
Converter redundancy	Single, twin, n-x
Max. converters	8
H configuration	Yes
Converter types	D5, UNL13300, UNL14300
PSS	2B/2C/4B
APSS	Yes
PEC controller generation	3
IEC 61850	Yes
Field breaker	AC (4,000) or DC

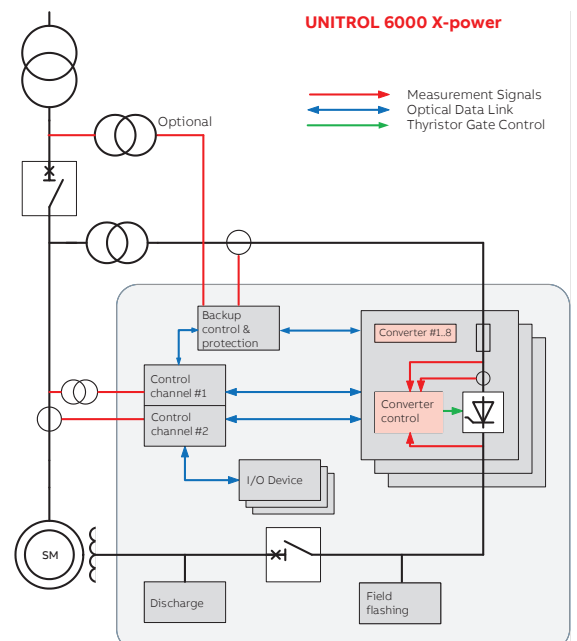

Control functions

All regulation, protection, and monitoring functions required for the secure operation of the generator are included as standard software features. To meet specific demands of any application, the software can easily be configured and adapted for the requirements.

Closed-loop control

- Voltage regulator with PID filter (AUTO mode)
- Field current regulator with PI filter (MAN mode)
- Reactive and/or active current droop compensation
- Limiter circuits to ensure that the generator operates within safe limits:
 - Maximum and minimum field current
 - Maximum stator current, dependent on machine cooling media temperature
 - P/Q under-excitation
 - Volt/Hertz
- Manual restrict to keep the generator within safe limits, even though controlled in manual mode
- Power factor/reactive load control
- Power system stabilizer

Protection and monitoring functions

- Monitoring and protection functions can be freely configured on three action levels:
 - Alarm signal only
 - Changeover to redundant circuits
 - Instantaneous excitation trip to protect the assets

Major available functions

- Overcurrent protection (instantaneous/inverse time)
- Volt/Hertz protection
- Loss of field protection
- Rotor temperature
- Thyristor conduction monitoring
- Actual value monitoring

Data and event recording

The internal event recorder function can handle and store up to 2,000 events, each provided with a real-time stamp. The data recorder contains a preconfigured part that records a huge set of measurements and internal signals. It is automatically triggered in case of a fault, to enable efficient troubleshooting and continuous improvement with the aim to maximize the availability. Additional free configurable high-speed recorders are available to be utilized during compliance testing or analysis of network events.

System time synchronization

The system clock of all the controllers can be synchronized with a time source by Simple Network Time Protocol (SNTP) with an accuracy of up to 1 ms to allow efficient troubleshooting and align excitation event-logs with other loggers of the plant and minimize the time to get the unit back on the grid.

Power system stabilizer (PSS)

The PSS function improves the stability of the generator and the transmission system by using the excitation to damp power oscillations.

PSS types optionally available for UNITROL® 6000:

- PSS 2A/2B/2C in accordance with IEEE standard 421.5-2016
- PSS 4B/4C in accordance with IEEE standard 421.5-2016
- Adaptive PSS (APSS) developed by ABB Switzerland, which optimizes the PSS settings based on the current network conditions, to maximize availability and avoid trips due to insufficient damping in weak networks

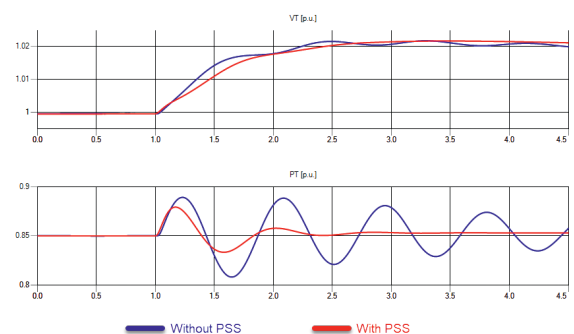

Synchronous machine transient simulator – real time (SMTS-RT 6000)

SMTS-RT 6000 is a “Hardware in the loop” simulator, which simulates a generator/motor, its turbine/ load and the grid. The simulator is connected to the excitation system for closed-loop tests to analyze its stationary and transient behavior. The SMTS-RT 6000 reduces the testing time of your machine, saves costs, and serves as ideal training tool for maintenance and operation personnel. Commissioning time can be further reduced by tuning control parameter sets in advance, using the simulator and a UNITROL® 6000 control device.

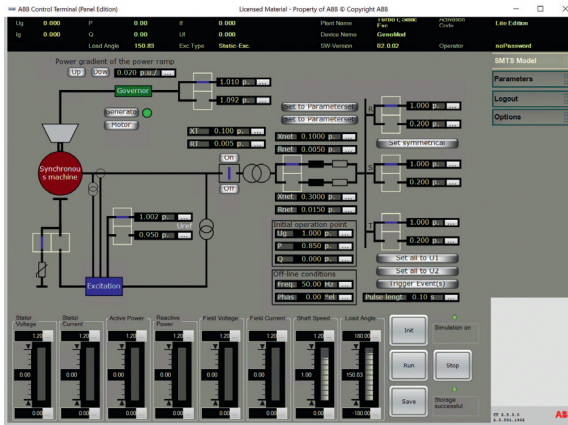

Grid codes

UNITROL® 6000 control functionality is prepared to support any grid code. The extensive testing functions and powerful data recorders of the excitation control terminal (ECT) serve to test, tune, and prove the performance of control, stabilizer and limiter functions. System frequency response can be analyzed quickly and accurately using the built-in white noise generator. This method executes compliance testing in minimal time.

Data records are stored in the ECT’s dedicated memory and can be easily copied and integrated into electronic documents.

In combination with SMTS-RT 6000, it is possible to simulate the most critical plant or grid conditions, which are typically impossible to test safely within the real system.

Complexity of power grids, smart grids, microgrids, distributed and variable energy resources.

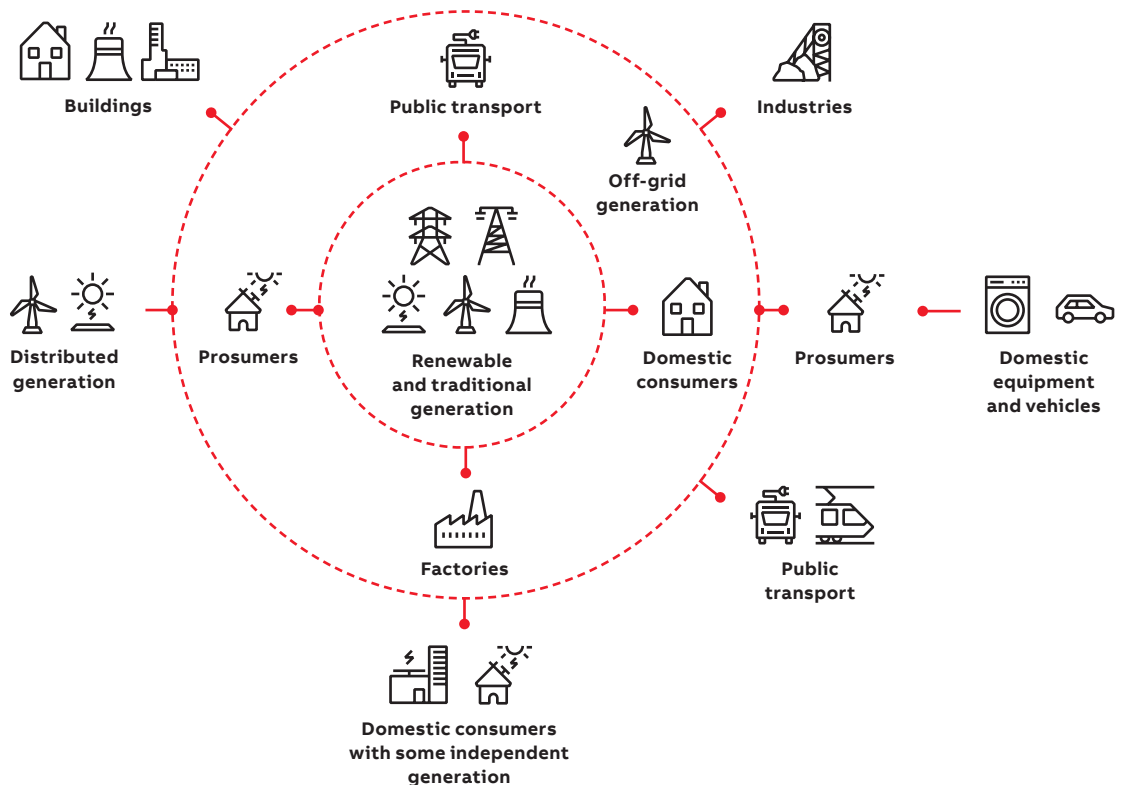

Hardware components

The system is based on the AC 800PEC high-performance processor family. It is an extension of ABB's 800xA control platform, developed to meet the fast control requirements of power electronics.

Control

The AC 800PEC control system excels in very high processing speed, providing:

- Fast analog and digital process I/Os with a typical cycle time of 400 µs
- Fast closed-loop control and regular process logic implemented in a single controller
- Low-speed I/Os with a typical cycle time of 10 ms
- Very fast programmable logic for converter pulse control and optical communication with cycle time down to 25 ns

Power converter

The power converter of each channel is selected to meet the system requirements with respect to maximum field current and voltage. Stringent availability requirements are fulfilled with up to three redundant channels and provisions for online maintenance (optional). ABB has developed a range of thyristor power converters dedicated to direct (static) and indirect excitation systems, for example D1 to D5, UNL13300 and UNL14300.

Main features (D1 to D5)

- Single- or three-phase AC supply voltage up to 1,080 V
- Rated supply frequency from 50 to 480 Hz (16 $\frac{2}{3}$ Hz on request)
- Low noise level of cooling fans ≤ 70 dB(A)
- Compact, fully integrated converter and control with an integrated service panel

Main features (UNL14300)

- AC supply voltage up to 1,500 V
- High insulation test voltages up to 7.5 kV
- Low noise level of cooling fans ≤ 70 dB(A)
- Active current balance control
- Optional:
 - Redundant fans, replaceable during operation
 - "Draw-out" design for safe online repair and function tests

01 D1–D5 power converter

02 UNL14300 power converter



02



Communication features

The communication features of UNITROL® 6000 systems ensure simple and user-friendly human machine interaction, whether it comes to system commissioning or integration into the plant control system.

Excitation control terminal (ECT)

The ECT is a user-friendly human machine interface that enables operation, monitoring, and maintenance of the system. It is a powerful industrial grade touchscreen PC that runs independently of the system's controller. Events and system data can be recorded over a long period of time. The LCD touchscreen provides the operator with a range of selectable screens showing information on the actual status of the system in graphical and numerical form. The control terminal operates under Windows 10 and can also be installed on any PC for commissioning purposes.

Integration into the plant control system

Ethernet and fieldbus protocols Modbus-RTU, Modbus-TCP, and Profibus DP-V0 as well as IEC 61850 are the main choices for communication with the plant control system. Emergency control signals can be hardwired directly to the control board.

Remote services

Remote services and troubleshooting help reduce costs associated with repair and service time.

UNITROL® 6000 is enabled for remote access with the aid of ABB RAP platform or customer internal tools. Thus, the local maintenance team can get the necessary support from ABB service specialists.

01 Excitation Control Terminal operator screen selections

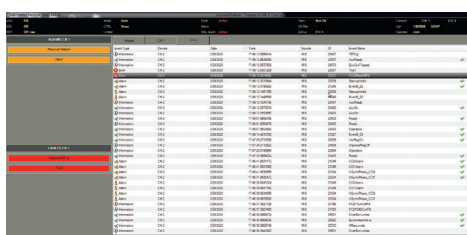
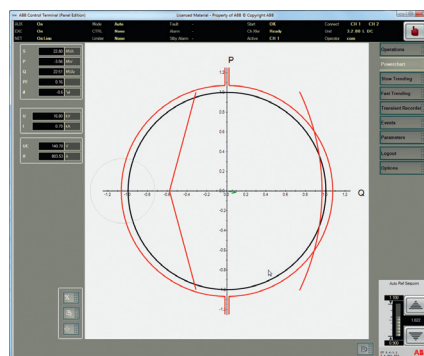

Service and support

For life cycle management or technical support, the worldwide network of UNITROL® specialists is at your service.

Installation and commissioning

The professionalism, extensive experience, and multilingual skills of ABB's engineers ensure satisfactory installation and commissioning.

Training

ABB University offers standard and customized training courses for UNITROL® 6000 excitation systems. Virtual and on-site training options are available. For detailed training programs, visit www.abb.com/abbuniversity.

Life cycle management

ABB's excitation systems life cycle management model helps the customers extend and maximize the life cycle of their assets at minimum costs. Depending on the product's life cycle phase, the service specialists recommend necessary

actions and approach the clients proactively to inform them of all maintenance, service, and upgrade requirements. We have a comprehensive Excitation Care program to cover all customer maintenance needs.

Examples of life cycle services:

- Technical support for optimized reliability
- Remote services
- Maintenance and repairs
- Extension, upgrades, and retrofits

Complete life cycle services are guaranteed for the active and classic phases. As soon as the system enters the limited phase, it is recommended to start planning an upgrade, or retrofit the equipment with ABB's latest technology.

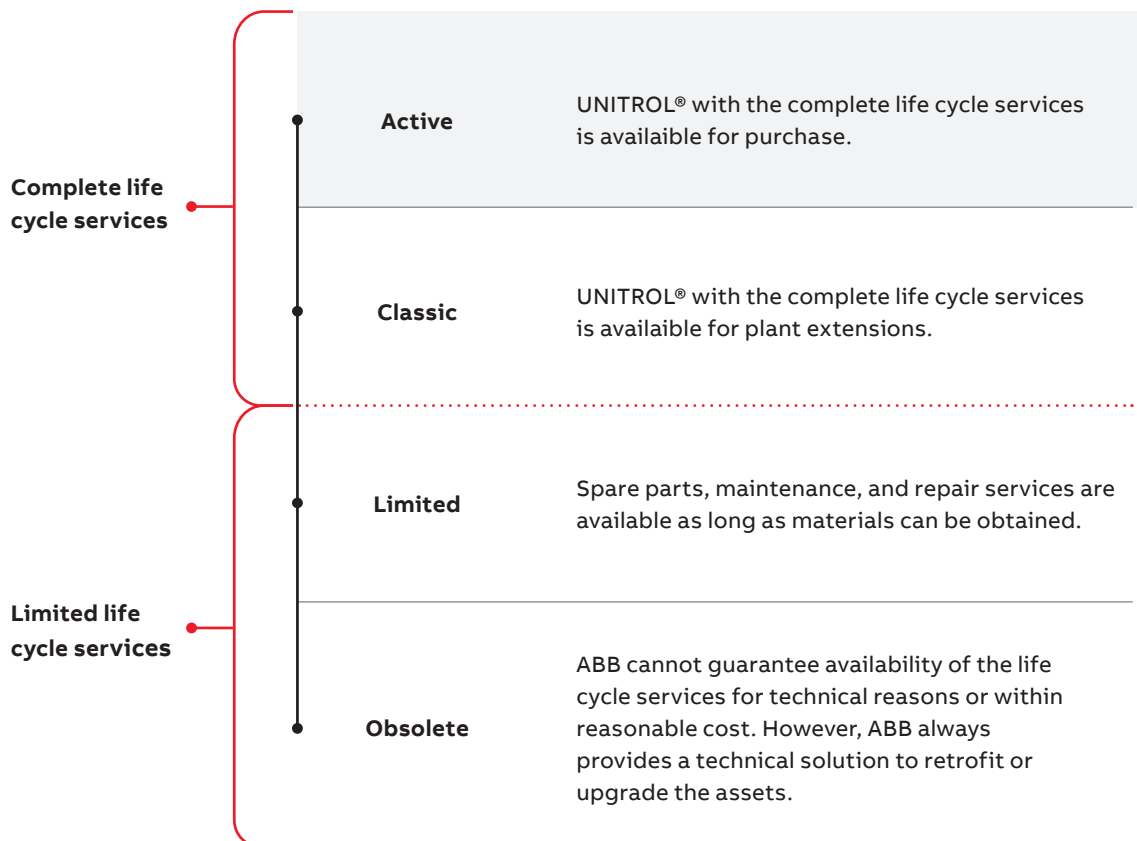



Technical support

- Large global team of certified engineers
- Highly experienced experts in ABB excitation systems and combined solutions provide fast and precise technical emergency assistance 24/7, 365 days a year
- Remote support available:
 - 24-hour hotline: +41 844 845 845
 - Email: unitrol.supportline@ch.abb.com

Excitation Care

Provides a simple and structured way to support your assets throughout their life cycle. It offers customizable service levels with optional packages to cover different maintenance needs.

Benefits

- Simplifies service delivery
- Reduces maintenance cost
- Supports your operations with digital services
- Provides access to ABB ability Remote Insights and the Remote Access Platform (RAP) for faster troubleshooting
- Increases the reliability of the system by providing proactive maintenance programs
- Supports transfer of knowledge through our trainings, offered as virtual or face to face.

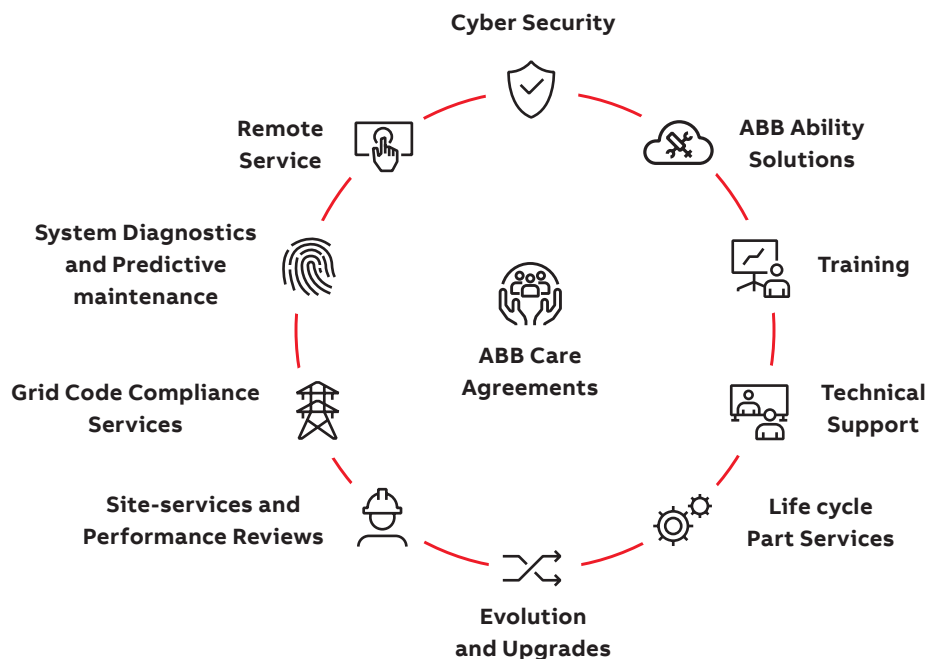



—

ABB Ltd
Excitation Systems
and Synchronizing Equipment

CH-5300 Turgi, Switzerland

Phone: +41 (0)58 589 24 86

E-Mail: pes@ch.abb.com

www.abb.com/unitrol