

Motor Protection Relay

SPAM 150 C

Product Guide

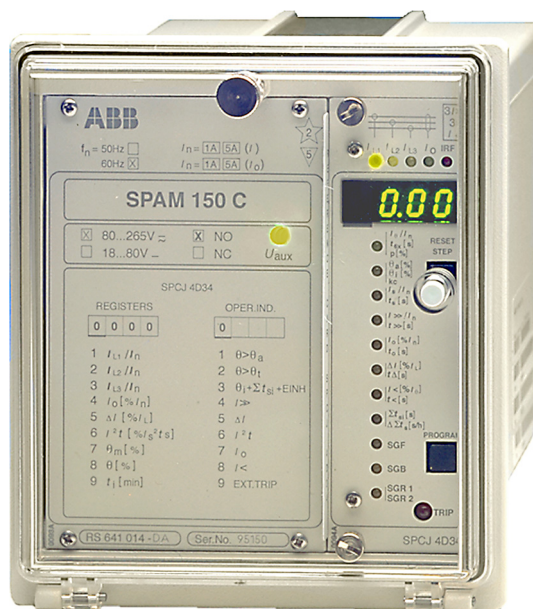

Features

- Versatile multifunction relay for the protection of circuit breaker or contactor controlled a.c. motors
- The relay can also be used for the protection of feeders and transformers
- Three-phase thermal overload protection
- High-set overcurrent protection with instantaneous or with definite time operation
- Phase unbalance and single-phasing protection with inverse time characteristic
- Fast operating incorrect phase sequence protection
- Sensitive earth-fault protection with definite time characteristic
- Undercurrent protection with definite time characteristic
- Several selectable motor start-up supervision methods
- Continuous self-supervision of hardware and software
- Current range handled meets the requirements for ExE motor drives of Zone 1
- Sophisticated self-supervision system with auto-diagnostics
- Interface for extensive data exchange with the substation level data acquisition and control system over fibre-optic bus
- Powerful software support for parametrization of the relay, for reading measured and recorded values, events, etc. and for storing readings
- Member of the SPACOM product family and ABB's Distribution Automation system
- CE marking according to the EC directive for EMC

Application

The numerical motor protection relay SPAM 150 C is an integrated design current measuring multifunction relay for the complete protection of a.c. motors. The main area of application covers large or medium-sized three-phase motors in all types of conventional contactor or circuit-breaker controlled motor drives. The motor protection relay is

available in two versions, one with a making trip contact and the other with a breaking trip contact.

The relay can also be used for the protection of other objects, such as transformers and feeders, requiring a single-, two- or three-phase overcurrent and/or overload protection and non-directional earth-fault protection.

Design

The relay continuously measure the three phase currents and the residual current of the protected object. When a fault occurs, the relay starts and eventually operates, if the fault persists long enough to exceed the set or calculated operate time of the relay.

The motor protection relay consists of a multi-function relay module SPCJ 4D34, an input/output module and an auxiliary supply module housed in a size 100 relay case.

The multi-function relay module comprises seven units, i.e. a three-phase overcurrent unit, a thermal overload unit, start-up supervision unit, a phase unbalance unit, an incorrect phase sequence unit, an undercurrent unit and a non-directional earth-fault unit.

The overcurrent unit holds a low-set stage I_s and a high-set stage $I_{>>}$. The high-set stage provides short-circuit protection. The low-set stage can be used for start-up supervision or for time overcurrent protection.

The thermal unit supervises the thermal stress of the protected object during various load conditions. The unit provides thermal prior alarm and thermal tripping and it prevents the protected object from being re-energized, if the protected object is too hot to be successfully re-energized.

The start-up supervision can be realized according to several principles. It can be based on measuring the start time, on measuring the thermal stress at start-up or on the use of an external speed switch.

The phase unbalance unit protects, e.g. motors, from the stress caused by an unbalanced network. The unit operates with inverse time characteristic. The operate time of the unit at full unbalance, i.e. at loss of one phase is 1 second.

The incorrect phase sequence protection has a factory-set operate time of 0.6 seconds.

The undercurrent unit is used for the protection of motors at sudden loss of load in certain applications, such as conveyors and submersible pumps. The unit features definite time characteristic.

Data communication

The relay is provided with a serial interface on the rear panel. By means of a bus connection module type SPA-ZC21 or SPA-ZC 17 the feeder protection relay can be connected to the fibre-optic SPA bus. The bus connection module SPA-ZC 21 is powered from the host relay, whereas the bus connection module type SPA-ZC 17 is provided with a built-in power unit, which can be fed from an external secured power source. Via the SPA bus the relay communicates with higher-level data acquisition and control systems.

Self-supervision

The relay incorporates a sophisticated self-supervision system with auto-diagnosis, which increases the availability of the relay and the reliability of the system. The self-supervision system continuously monitors the hardware and the software of the relay. The system also supervises the operation of the auxiliary supply module and the voltages generated by the module.

On detection of a permanent internal relay fault the IRF indicator on the relay front panel is lit. At the same time the output relay of the self-supervision system operates and a fault message is transmitted over the serial bus to the higher-level system. Further, in most fault situations a fault code is shown in the display of the protection relay module. The fault code indicates the type of fault that has been detected.

Auxiliary supply voltage

The auxiliary supply of the relay is obtained from an internal plug-in type power supply module. Four auxiliary power module versions are available, type SPTU 240R2 and SPTU 240R3 for the supply voltage range 80...265 V ac/dc and type SPTU 48R2 and SPTU 48R3 for the supply voltage range 18...80 V dc. The power supply module forms the internal voltages required by the protection relay and the I/O module.

The auxiliary power modules also hold the output relays of the relay. The types SPTU 240R2 and SPTU 48R2 incorporate a normally open trip contact and the types SPTU 240R3 and SPTU 48R3 a normally closed trip contact.

Technical data

Table 1: Energizing inputs

Terminals		1-4, 4-6, 7-9, 25-27	1-2, 4-5, 7-8, 25-26
Rated current I_n		1 A	5 A
Thermal withstand capability	continuously	4 A	20 A
	for 10 s	25 A	100 A
	for 1 s	100 A	500 A
Dynamic current withstand capability	Half-wave value	250 A	1250 A
Input impedance		<100 m Ω	<20 m Ω
Phase current monitoring range		0...63 x I_n	
Neutral current monitoring range		0...210% of I_n	
Rated frequency f_n , according to order		50 Hz or 60 Hz	

Table 2: Output contact ratings

Type of contact		NO trip	NC trip	Signalling
Terminals		65-66, 74-75	65-66	70-71-72, 68-69, 77-78, 80-81
Rated voltage		250 V ac/dc		
Thermal withstand capability	Carry continuously	5 A	5 A	5 A
	Make and carry for 0.5 s	30 A	10 A	10 A
	Make and carry for 3 s	15 A	8 A	8 A
Breaking capacity for dc, when the control/signalling circuit time constant $L/R \leq 40$ ms, at the control voltages	220 V dc	1 A	0.15 A	0.15 A
	110 V dc	3 A	0.25 A	0.25 A
	48 V dc	5 A	1 A	1 A

Table 3: Control input, communication and power supply

External control input	Terminals	10-11		
	Control voltage level	18...265 V dc or 80...265 V ac		
	Power consumption when input activated	2...20 mA		
Data communication	Transmission mode	Fibre optic serial bus		
	Data code	ASCII		
	Selectable data transfer rates	300, 1200, 2400, 4800 or 9600 Bd		
	Fibre optic bus connection module, powered from the host relay	for plastic fibre cables	SPA-ZC 21BB	
		for glass fibre cables	SPA-ZC 21MM	
	Fibre optic bus connection module with a built-in power supply unit	for plastic fibre cables	SPA-ZC 17BB	
for glass fibre cables		SPA-ZC 17MM		
Auxiliary supply modules	Power supply and I/O modules and voltage ranges	SPTU 240R2/-R3	80...265 V ac/dc	
		SPTU 48R2/-R3	18...80 V dc	
	Power consumption	under quiescent conditions	~4 W	
		under operating conditions	~6 W	

Technical data (cont'd)

Table 4: Motor protection relay module SPCJ 4D34

Thermal overload unit	Full load current I_0	$0.50 \dots 1.50 \times I_n$
	Weighting factor for thermal unit curves p	20...100%
	Safe stall time setting t_{6x} , i.e. trip time at locked rotor from cold motor	2.0...120 s
	Cooling time multiplier k_c , for motor at standstill	$1 \dots 64 \times \tau_h$ (τ_h = heating time constant)
	Thermal prior alarm level θ_a	50...100% of θ_t (θ_t = thermal trip level)
	Motor restart inhibit level θ_i	20...80% of θ_t
	Thermal initialization level on restoration of auxiliary supply	70% of θ_t , i.e. hot motor
Start-up supervision unit	Start current I_s	$1.0 \dots 10.0 \times I_n$
	Start-up time t_s	0.3...80.0 s
	Two operation principles	definite time principle (I & t) thermal stress principle ($I^2 \times t$)
High-set phase overcurrent unit	Start current $I_{>>}$	$0.5 \dots 20.0 \times I_n$ or ∞ , infinite
	Operate time $t_{>>}$	0.04...30.0 s
Earth-fault unit	Start current $I_{0>}$	$1.0 \dots 100\%$ of I_n
	Operate time $t_{0>}$	0.05...30.0 s
Phase unbalance/incorrect phase sequence unit	Start current ΔI	$10 \dots 40\%$ of I_L (I_L = Load current)
	Operate time t_{Δ} , at lowest possible setting, i.e. 10%	20...120 s
	Operation characteristic	Inverse time
	Operate time at 100% phase unbalance (single phasing)	1 s
	Operate time at incorrect phase sequence	600 ms
Undercurrent unit	Start current $I_{<}$	$30 \dots 80\%$ of I_q
	Operation inhibit level	<12% of I_q
	Operate time $t_{<}$	2...600 s
Cumulative start-up time counter unit	Restart inhibit level of cumulative start time counter $\sum_{t_{si}}$	5...500 s
	Countdown rate of start-up time counter $\Delta \sum t_s / \Delta t$	2...250 s/h

Technical data (cont'd)

Table 5: Tests and standards

Test voltages	Dielectric test voltage (IEC 60255-5)	2.0 kV, 50 Hz, 1 min
	Impulse test voltage (IEC 60255-5)	5 kV, 1.2/50 μ s, 0.5 J
	Insulation resistance (IEC 60255-5)	>100 M Ω , 500 V dc
Interference tests	High-frequency (1 MHz) disturbance test (IEC 60255-22-1), common mode	2.5 kV
	High-frequency (1 MHz) disturbance test (IEC 60255-22-1), differential mode	1.0 kV
	Fast transients (IEC 60255-22-4, class III and IEC 61000-4-4), power supply inputs	4 kV, 5/50 ns
	Fast transients (IEC 60255-22-4, class III and IEC 61000-4-4), other inputs	2 kV, 5/50 ns
	Electrostatic discharge (IEC 60255-22-2 and IEC 61000-4-2), air discharge	8 kV
	Electrostatic discharge (IEC 60255-22-2 and IEC 61000-4-2), contact discharge	6 kV
	Mechanical test	Seismic test (ANSI/IEEE C37.98-1987), operating basis earth-quake test
Seismic test (ANSI/IEEE C37.98-1987), safe shut down earth-quake test		0.5...7.5 g
Vibration test		2...13.2 Hz, \pm 1.0 mm 13.2...100 Hz, \pm 0.7 g
Shock/bump test (IEC 60255-21-2)		20 g, 1000 bumps/direction
Corrosion test		Battelle test
Environmental conditions	Service temperature range	-10...+55°C
	Transport and storage temperature range (IEC 60068-2-8)	-40...+70°C
	Damp heat test (IEC 60068-2-3)	<95%, +40°C, 96 h
	Degree of protection by enclosure when panel mounted	IP 54
	Weight	~3.5 kg

Block diagram

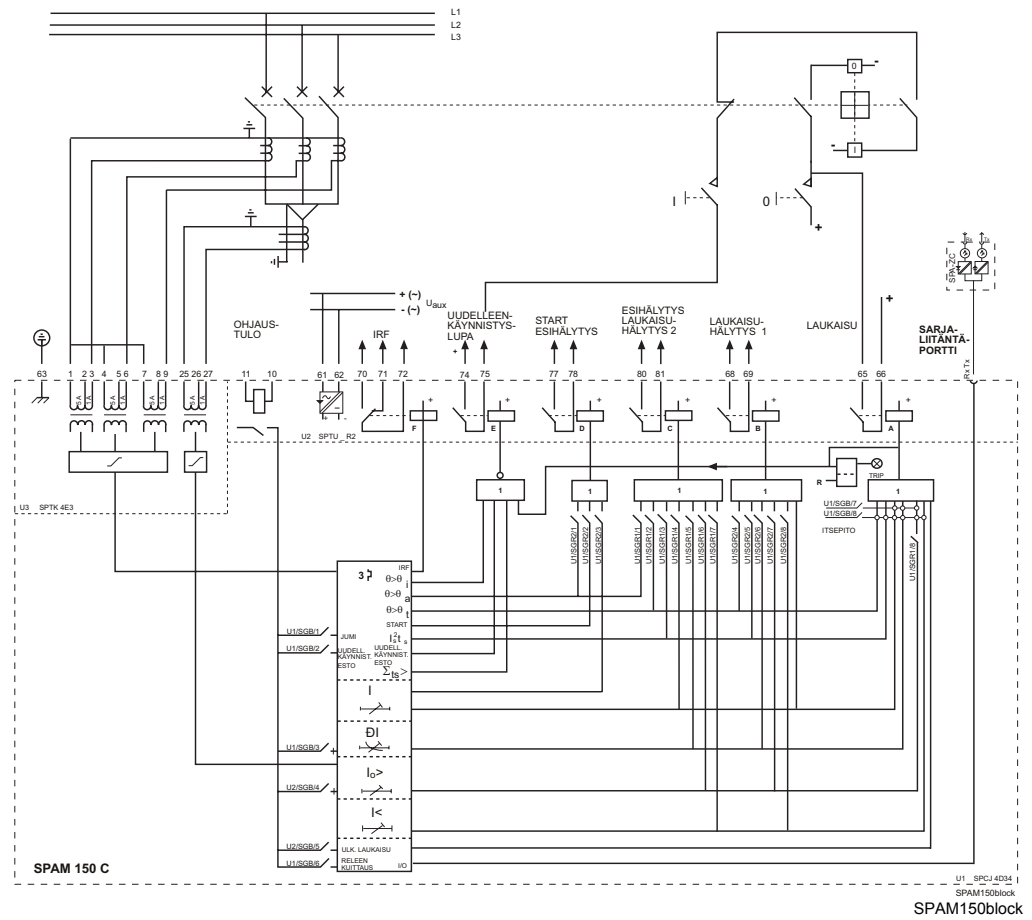

Fig. 1 Block diagram and sample connection diagram

Mounting and dimensions

Flush mounting

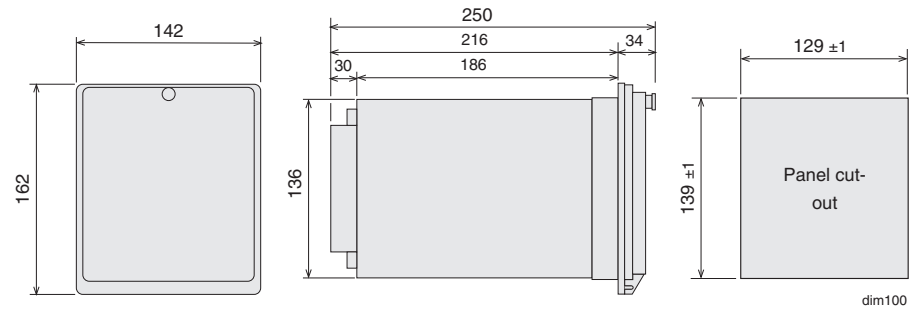
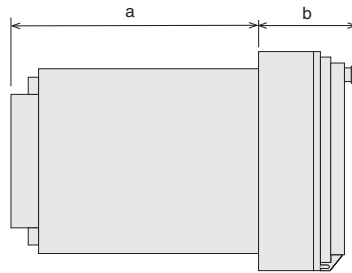

Fig. 2 Flush-mounting relay case (dimensions in mm)

Semi-flush mounting



Raising frame	a	b
SPA-ZX 111	176	74
SPA-ZX 112	136	114
SPA-ZX 113	96	154

SFM100_1

Fig. 3 Semi-flush mounting relay case (dimensions in mm)

Mounting in 19 inch cabinets and frames

An ancillary mounting plate, height 4U (~177 mm), is recommended to be used when the protection relays are to be mounted in 19 inch frames or cabinets. The ancillary mounting plate type SPA-ZX 104 accommodates three relays, type SPA-ZX 105 two relays and type SPA-ZX 106 one relay.

SPA-ZX104
SPA-ZX105
SPA-ZX106

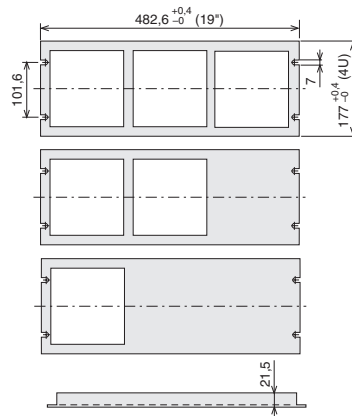

SPA-ZX110
SPA-ZX115

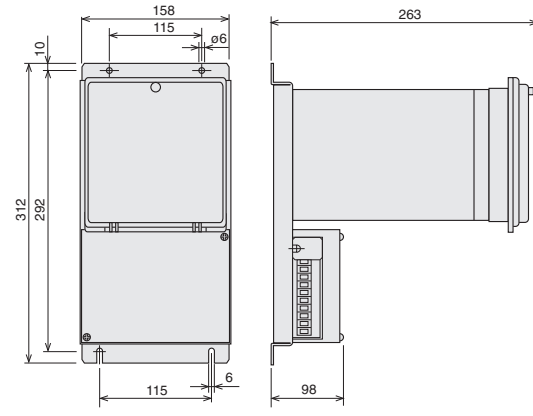

104_6_10

Fig. 4 Mounting cabinets and frames as well as projecting mounting (dimensions in mm)

Projecting mounting

When projecting mounting is preferred, a relay case type SPA-ZX 110 is used. The relay case for projecting mounting is provided with front connectors.

Ordering

When ordering, please specify:

Ordering information	Ordering example
1. Type designation and quantity	SPAM 150 C, 5 pieces
2. Order number	RS 641 014-AA
3. Rated frequency	$I_n=5\text{ A}$, $f_n = 50\text{ Hz}$
4. Auxiliary voltage	$U_{aux} = 110\text{ V dc}$
5. Accessories	-
6. Special requirements	-

Order numbers

Motor protection relays SPAM 150	
SPAM 150 C with NO trip contact	RS 641 014-AA, CA, DA, FA
SPAM 150 C with NC trip contact	RS 641 015-AB, CB, DB, FB
The last two letters of the order number indicate the rated frequency f_n and the auxiliary voltage U_{aux} of the relay as follows:	AA and AB equal $f_n = 50\text{ Hz}$ and $U_{aux} = 80\dots265\text{ V ac/dc}$
	CA and CB equal $f_n = 50\text{ Hz}$ and $U_{aux} = 18\dots80\text{ V dc}$
	DA and DB equal $f_n = 60\text{ Hz}$ and $U_{aux} = 80\dots265\text{ V ac/dc}$
	FA and FB equal $f_n = 60\text{ Hz}$ and $U_{aux} = 18\dots80\text{ V dc}$

Motor protection relays SPAM 150 with test adapter RTXP 18	
SPAM 150 C with NO trip contact	RS 641 214-AA, CA, DA, FA
SPAM 150 C with NC trip contact	RS 641 215-AB, CB, DB, FB
The last two letters of the order number indicate the rated frequency f_n and the auxiliary voltage U_{aux} of the relay as follows:	AA and AB equal $f_n = 50\text{ Hz}$ and $U_{aux} = 80\dots265\text{ V ac/dc}$
	CA and CB equal $f_n = 50\text{ Hz}$ and $U_{aux} = 18\dots80\text{ V dc}$
	DA and DB equal $f_n = 60\text{ Hz}$ and $U_{aux} = 80\dots265\text{ V ac/dc}$
	FA and FB equal $f_n = 60\text{ Hz}$ and $U_{aux} = 18\dots80\text{ V dc}$

References

Additional information

Manual "Motor Protection Calculation Tool for SPAM 150 C"	1MRS 750593-EEG EN
Manual "Motor protection relay SPAM 150 C"	1MRS 750637-MUM EN



ABB Oy, Distribution Automation

P.O. Box 699
FI-65101 Vaasa, FINLAND
Tel +358 10 22 11
Fax +358 10 224 1094
www.abb.com/substationautomation

ABB Limited, Distribution Automation

Maneja , Vadodara - 390013, India
Tel +91 265 260 4386
Fax +91 265 263 8922
www.abb.com/substationautomation