

2 | 12

An ABB technical journal
for Enclosures and
DIN rail Products users

Day ^{by} DIN



News and know-how for informed professionals

Let's construct the safety of extra low voltage

Using power supply in extra low voltage to ensure service continuity and safety at the same time.

Energy efficiency in buildings

All you need to know about EN 15232 energy classes and building automation solutions

Power and productivity
for a better world™





One system for all application?

Certainly.

TwinLine – ABB’s innovative Sub-Distribution system. This fully comprehensive product range includes wall-mounting and floor-standing cabinets in three depths and all with the high IP55 degree of protection. TwinLine is available in the three cabinet types TwinLine-G (depth of 225 mm), TwinLine-L (275 mm) and TwinLine-W (350 mm). All TwinLine cabinets meet the requirements defined in IEC 61439 and DIN EN 61439 Part 1 and Part 2 and are designed according to the protection classes I and II. Intelligent adaptations such as the innovative flange technology, uniform fastening for all internal configurations, optimal accessibility, ease of connection and the modular plinth concept guarantee its high ease of installation. www.abb.com/lowvoltage



Ancient energy and modern automation. (68)

Day by DIN 2|12



Emanuele Tosatti
Product Marketing Manager
DIN Rail Products

Thank you! The first issue of Day by DIN, both in hardcopy and digital edition, has been a success above our expectation. Thousands of passionate readers around the entire globe enjoyed its sections and articles and I want to introduce this second issue heartily thanking all of you! The best way to show ABB Customers our commitment is, for all editors of Day by DIN, to serve you even more fresh news, articles and technical insight about our business. In this issue you will enjoy a wide technical overview about the blooming business of eMobility, several pages about circuit breakers technology and applications, an amazing story about how to join tradition with innovative

energy efficiency solutions, plus a present we wish you will carefully keep with you: a surge protective devices selection table, to find the right SPD for your application at a glance! Furthermore, as we know electricity is only one of the topics you need to master to be successful in business, some basic knowledge and curiosities about marketing and selling your solutions to your present and new customers. Finally, to ensure you will always be the first to get your copy, now you can subscribe to Day by DIN and get next issues as hardcopy or by email right to your mailbox. What else? Discover it page by page and... enjoy Day by DIN!

Is Day by DIN interesting for you and you want it free of charge?

Make now your subscription filling the form you find at the following link: <http://goo.gl/XXeMg> or capturing the QR Code beside with your smartphone. You'll receive your personal printed copy of this issue and all the new ones coming in the future.





40 **Let's construct the safety of extra low voltage**
Using power supply in extra low voltage to ensure service continuity and safety at the same time.



52 **Energy efficiency in buildings**
All you need to know about EN 15232 energy classes and building automation solutions

News and facts

- 6 Jump in the box**
Fresh news from ABB for your installation!
- 14 In the news**
Literature on our latest products
- 20 Top six**
Market classification

The expert answers

- 22 Good morning DIN rail**
The editor responds
- 108 Quiz**
Tests for those who are really skilled

Doktor Wise

- 38 Doktor Wise**
The expert answers
- 90 Switching off instead of blowing.**
Make profits with miniature circuit breakers
Some benefits of an MCB compared to a fuse are still unfamiliar. Let's discover all of them!
- 106 TwinLine – ABB's innovative Sub-Distribution system**
How to save money and time with TwinLine system.

Curiosity

- 51 Electric power and modernity:**
new scenarios, new possibilities

Case History

- 68 Ancient energy and modern automation**
Efficient and sustainable solutions for a riverside hotel

Technical

- 24 Insulation monitoring**
Operational continuity thanks to IT distribution systems
- 28 IEC 61439**
The new standard for low-voltage switchgear and controlgear ASSEMBLIES
- 32 Dear stand-by, how much you are costing me...**
A hidden energy waste in the heart of our home, and how to prevent it!
- 36 Seen from within!**
The hidden aspect of everyday devices
- 40 Let's construct the safety of extra low voltage**
Using power supply in extra low voltage to ensure service continuity and safety at the same time.
- 46 Harmonics and neutral surge survey**
Where do harmonics come from, why can't we live without and how to manage them, safely.

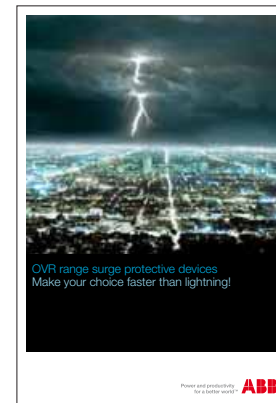
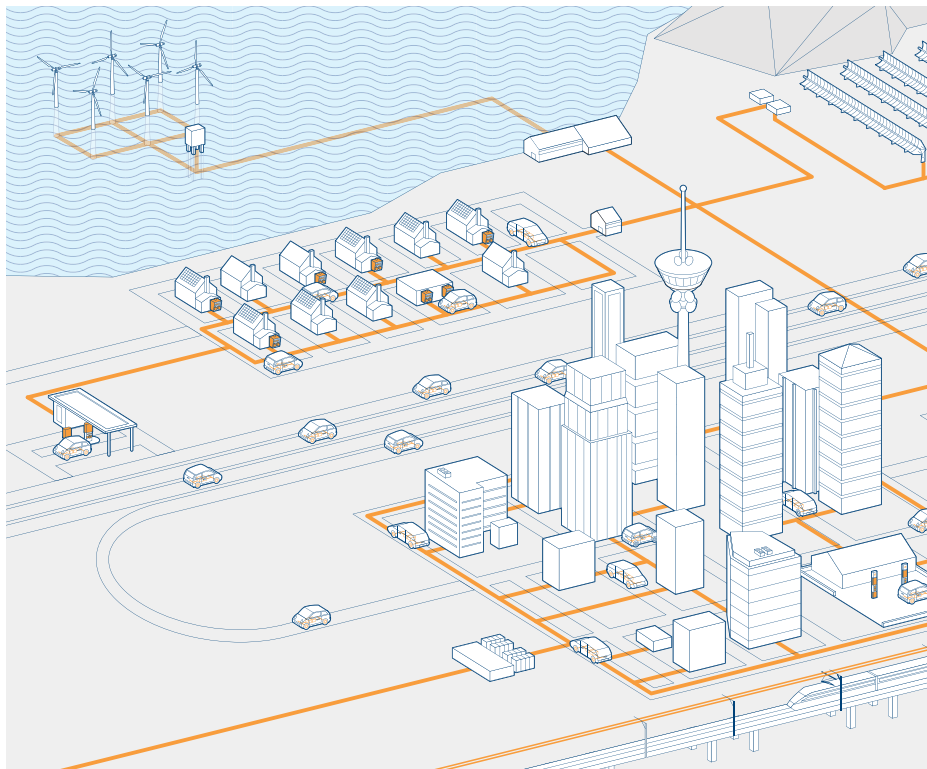

Special insert

Surge protective devices
selection guide

56

The new era in electric mobility

Electrical vehicles are now a reality: learn how do they work and get ready to feed them safely!

52 Energy efficiency in buildings

All you need to know about EN 15232 energy classes and building automation solutions

56 The new era in electric mobility

Electrical vehicles are now a reality: learn how do they work and get ready to feed them safely!

74 Improve supply continuity in low-voltage installations through selective main circuit-breakers!

Main circuit protection and isolation made safe and reliable with MCBCs.

76 The importance of energy saving starting with a twilight switch

The correct use of twilight switches is the ideal solution to cut consumption and pollutant emissions of public lighting systems.

80 UL 1077 and UL 489 differentiation

Two UL standards for circuit protection in United States? Here's why and where!

84 Overheating in electrical switchgears

94 New design for a fast current limiting and interrupting device

Short circuit currents limiting steps forward thanks to ABB research. Take a look at the future of MCB!

102 How to choose an optimized External Lightning Protection (ELP)

OPR external lightning protection: The easy way to avoid the sky falling on your heads!

Report

83 MCB versus a rubber duck

A not really fair comparison

97 Customer feedback. Surge Protective Devices OVR NE12 Series - Enclosed SPD Mining and Aggregates

98 Lights on for EURO 2012

99 ABB Wizard:

the right choice which is always accessible.

100 From electrician to marketer: pump up your business!

Time to attract new customers and improve your business? Easier if you know marketing and sales essentials!

Time to relax

110 Connect the boxes

Jump in the box

ABB's newest products and solutions from Enclosures and DIN Rail Products world! In this issue new miniature circuit breakers, time switches, KNX products and more.

Protection

MCB S200M UC

A real all-rounder: flexible control of both direct and alternating currents

The S200M UC impresses with its performance range and high number of approvals. Moreover, its flexible application for both DC and AC makes it a valuable addition to the System pro *M* compact® range. Whether warehousing and project engineering, planning and installation or maintaining equipment, the S200M UC is an easy to use and flexible solution.

Brochure: 2CDC002140L0201



Benefits

- For DC and AC applications
- Improved terminal technology
- Excellent technical data
- Wide range of approvals
- Contact position indication
- One module width even with integrated auxiliary contact
- Fully compatible with System pro *M* compact® accessories

Command

MCB – S800PV-M-H

Switch disconnecter 1000V DC within 54 mm



S802PV-M-H, is a 2-pole disconnecter for voltages up to 1000V DC and for rated currents up to 100A. The S802PV-M-H, as well as the ABB worldwide success S800PV-M, is specifically designed as mains string box disconnecter and finds ideal application in combination with E 90 PV fuseholders and E 9F PV fuses. S802PV-M-H completes the range of S800PV switch disconnectors, which features also two poles S802PV-M version, ideal as universal top/bottom supply solution up to 800V, three and four poles version S803PV-M and S804PV-M for isolation above 1000 V up to 1200V DC

Flyer: 2CCC413008L0201



Benefits

- Fast installation, no jumpers required
- Enhanced productivity and cost efficiency: power loss 50% smaller than 4-pole design
- High temperature performance, no derating up to 60°C ambient temperature
- Space saving, thanks to 54 mm width
- Wide rated current range of 32A, 63A and 100A
- Utilization category DC-21A: switching of ohmic load, including minimal overload, switching 1500 times under load
- Compatible with S800PV accessories range

Protection

MCB – S800B

The large one of the small ones

Designed to meet the current needs of sub-distribution cabinets and IEC 60947-2 requirements up to 16kA and 125A at 230/400 V AC.

Technical catalogue: 2CCC413003C0202



Benefits

- MCB with 16kA breaking capacity up to 125 Amps
- No polarity: can be supplied from the top or the bottom

Protection

MCB – S200PR - SU200PR

The new ring cable lug connection

S200PR and SU200PR are high-performance circuit breakers with ring cable lug connections conforming to UL and CSA standards. The integrated captive mounting screw simplifies the connection of electric lines, provides extra protection and saves time. The circuit breaker is a valuable addition to the proven System pro *M* compact® range which allow most of the UL and CSA-approved components to be combined effortlessly with the new model line.

Data sheet: 2CDC002138D0201 for S200PR acc to UL1077/CSA22.2 No.235 and
2CDC002139D0201 for SU200PR acc to UL489/CSA22.2 No.5



Benefits

- Captive screws in the load side and supply side terminal
- Terminals touch safe (even with connected isolated ring lugs)
- S200PR Approved acc. to UL 1077, CSA 22.2 No. 235 and IEC/EN 60947-2
- SU200PR Approved acc. to UL 489, CSA 22.2 No.5 and IEC/EN 60947-2
- Wide range of ring lugs (AWG 18 – AWG 4)
- Compatible with most of the System pro *M* compact® accessories

Protection

SMCB S750DR

New range of selective main circuit-breakers



S750DR is a range of circuit-breakers dedicated to the protection of distribution circuits in any low-voltage installation. The working principle enables the highest degree of overcurrent selectivity/discrimination to downstream circuit-breakers giving the highest degree of continuity of service for the customer.



Benefits

- >30 years-proven technology for selective protection
- Total short-circuit selectivity to downstream mcb
- High current/energy limitation in case of short-circuits
- Supporting downstream circuit-breakers in current/energy limiting in case of short-circuits in final circuits
- Capable for isolation (main switching device)
- High isolation features
- Sealable/lockable
- Wide range of pole types, rated currents and characteristics

Surge protection

OVR T2 UL

New range of surge protective devices UL 1449 certified



The OVR NE12 enclosed and OVR T2 U surge protective devices (SPD) are the latest addition to ABB's extensive range of surge protection products. They are designed to be installed at the service entrance, thereby protecting the entire facility from the harmful effects of transient surges.

These surges are the result of:

- Direct and indirect lightning strikes
- Utility load switching
- Upstream load switching at other facilities

Catalogue: 1TXH000168C0201



Benefits

- Enclosed and DIN Rail version
- Short circuit withstand of 200kA
- High surge capacity from 160 to 320kA for the OVR NE12 and from 15 to 40kA for the OVR T2 U range
- Suitable for all type of networks
- Pluggable units
- Maximum operating voltages up to 600V
- UL 1449 3rd edition certified
- Wide range of pole types, nominal currents and characteristics

Surge protection

OVR T1 PV

New OVR Type 1 for photovoltaic installation

The OVR PV T1 complete the OVR PV specific range for photovoltaic networks. Thanks to the specific DC thermal disconnection, with quick response time and the insulation of the disconnection device from the varistor, they ensure a safe and reliable protection to the equipment.

Brochure: 2CSC432012B0301

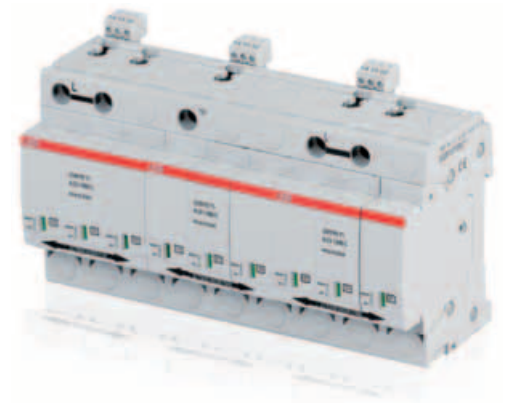

Benefits

- Specific PV disconnection
- Type 1 PV SPD with impulse current of 6.25kA
- Autoprotected up to 100A DC solar networks
- Suitable for 600V and 1000V DC networks
- Comply with UTE C 61 740-51
- Auxiliary contact for remote indication

Electricity meters

EQ meters A - series Gold

For increased awareness



Benefits

- Easy user interface
- Big and clear display
- Option of in-built communication
- MID approved and verified

New possibilities exist with new EQ meters Gold version's more advanced features which are made to make the work for you as a customer easier. The new EQ meters A-series Gold version includes an internal clock which enables saving data with time stamps, e.g. saving the energy register at midnight the last day of every month, or tell you when a power failure happened. To better understand your usage and utilise your energy consumption demand functionality is a great tool. The demand function will save the value together with a time stamp when ,e.g. the power, was at its highest and its lowest value.

This and much more is found in our new EQ meters range.

Command

D 365

Yearly digital time switches

D 365 is the new range of digital yearly time switches from ABB. D 365 resolves the continuous demands of automation systems in both residential and commercial segment. Primarily suited to handling medium automations, D 365 allows you to control more loads or groups of loads, which requires commands temporally differentiated, but with a single time reference. D 365 is characterized by extreme flexibility usage arising from the wide availability of 800 memory locations and by the possibility of handle up to 8 independent contacts.

Flyer: 2CSC440024B0201



Benefits

- 2 NO/NC independent contacts, expandable up to 8 contacts by using D365 CE
- 800 memory locations
- Standard, impulsive, cyclical, random and holiday programs
- Communication LAN, ETHERNET and POWERLINE
- Interchangeable battery

Intelligent Building Control

ABB i-bus KNX Energy Module

Made for interaction



The ABB i-bus KNX Energy Module EM/S 3.16.1 facilitates detailed analysis of energy consumption of electrical consumers in buildings, which are controlled via KNX.

Order code: 2CDG110148R0011



Benefits

- Active power measurement
- Various electrical values can be monitored
- Collection and presentation of active energy consumption in buildings
- Increasing the energy efficiency in buildings

Intelligent Building Control

ABB i-bus KNX

Room Master 3.1

Room Master 3.1 is ABB's latest addition to the range of Room Master solutions. Room Master devices offer all necessary electrical connection and control features required in defined functional areas (hotel rooms, apartments, school rooms) and substantially facilitate planning, installation and putting into operation new electrical installations. Conventional electrical installations and network-based KNX intelligent building installations are moving closer together.

Order code: 2CDG110165R0011



Benefits

- All functions for one room integrated into one device
- Preconfigured and tested ETS projects for different applications: e.g. for hotel rooms, apartments
- Internal connection of inputs and outputs, works without group addresses
- Extended functionality via optional integration in KNX networks with ETS software
- Application software available in 8 different languages: German, English, French, Spanish, Italian, Russian, Dutch and Polish

Intelligent Building Control

ABB i-bus KNX

Fan Coil Actuator, 0...10V



With the new fan coil actuator ABB completes its product range for room climate control with fan coil units. The device offers all necessary control outputs for the fan, the heating and cooling valves and an optional heating resistance. Additionally there are three inputs for signal contacts, e.g., to monitor window contact and drip tray. The polling voltage for the inputs is provided by the device.

Order code: 2CDG110141R0011



Benefits

- All necessary control outputs for the fan, the heating and cooling valves and an optional heating resistance of a fan coil unit
- Three inputs for signal contacts, e.g., to monitor window contact and drip tray
- Controls two analogue outputs, using an analogue control signal of 0...10 V for the heating and cooling valves
- Device can be operated manually
- No additional power supply needed

Measuring devices

CMS

Flexible and compact. A unique system for current measurement

CMS is a multichannel branch monitoring solution, which is able to measure both AC and DC currents in True RMS. Installation and integration in new and existing power distribution boards has never been easier. The sensors are mountable on ABB twin terminals either on MCBs, RCDs or RCBOs. The CMS offers sensors with measurement ranges of 20A, 40A and 80A. Special attention was paid to create an intuitive concept for operations when the menu navigation for the CMS was designed. Complex user training is not necessary, either for initialisation and for later operational use. The measurement data can be remotely queried by a RS 485 interface (Modbus RTU).

Brochure: 2CCC481002B0201

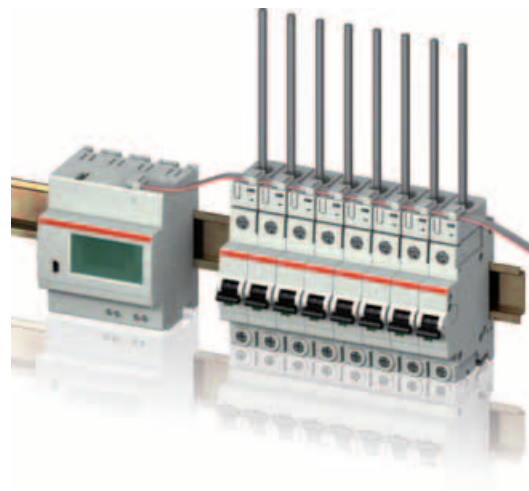

Benefits

- Space saving - only 17.4 mm wide units
- Ideal solution for retrofitting
- Huge measurement range up to 80A
- AC and DC measurement for universal use
- Quick installation & start up time
- User friendly system due to intuitive operation concept
- Contactless measurement for high reliability

Command

D SW

Programming software for D Line time switches



D SW can be run directly on your PC and allows a quick and easy programming of timers, comfortably sitting at your desk. Through D SW it is possible to copy the program on programming key and then transfer it on multiple devices, avoiding any reprogramming errors. The program, once created, can be saved in a PDF file format, ready to be printed and then preserved in the framework. D SW is available for order entry starting from now. Ordering D SW code, you will receive a USB key and a CD which includes programming software and technical documentation.



Benefits

- Quick and easy programming of D Line time switches
- USB key included in the package
- With USB key it is possible to copy the same program in several timers

In the news

Distribution and measurement, disconnection and protection: lots of new documents by ABB for those operating in the electrical business, helping them in their work.

The documents and the software can be downloaded from <http://www.abb.com/abblibrary/DownloadCenter/>

Protection

Efficiency you can touch

Smisline TP - The world's safest socket system

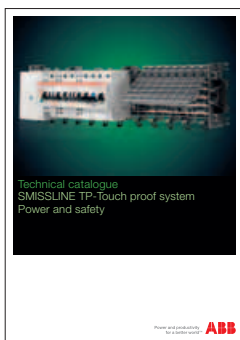

Small cause, large effect: as the world's first pluggable socket system, SMI SSLINE TP ensures that load-free devices and components can be snapped on and off under voltage without the need for additional personal protective equipment to guard against electrical hazards. The SMISLINE TP pluggable socket system is completely finger-safe (IP2XB) – when devices are plugged in and unplugged, the system is always touch-proof.

Technical catalogue: 2CCC451059C0201



Protection

The High Performance MCB

Safety and efficiency – all the way

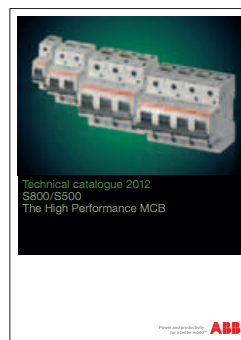

The S800 and S500 high performance circuit breakers are reliable switches: rated ultimate short-circuit breaking capacity up to 100 kA, adjustable or fixed rated tripping current, current rating up to 125 A, the most varied of characteristics and much more. The S800 and S500 are flexible, yet at the same time meet the highest safety requirements. See the variety for yourself!

Technical catalogue: 2CCC413003C0202



Protection

The High Performance MCB

S800 at a glance



The S800 high performance circuit breakers are reliable switches: rated ultimate short-circuit breaking capacity up to 100 kA, current rating up to 125 A, the most varied of characteristics and much more.

The S800 has multitude approvals for various applications and countries. Convince yourself and have a look!

Brochure: 2CCC413005L0201



Command

S800 photovoltaic switch disconnector

Less poles, more clarity



In times of increased pressure to save costs on photovoltaic systems, ABB is enabling further cost savings with the S802PV-M-H 2-pole disconnector.

Flyer: 2CCC413008L0201



Protection

The High Performance PV MCB range

Using the gift of the sun



The High-Performance MCB S800PV-S is developed for use in photovoltaic systems to offer reliable protection for PV modules and lines against reverse currents from defective strings and AC regenerative feedback due to defective inverters. With highly compact design for installation on the DIN rail, the S800PV-M switch disconnector offers safety-relevant isolation properties. As master switch for PV systems, the whole DC side can thus be safely isolated up to 1200 V DC! The combination of our PV range and the remote switching unit makes the use even more convenient and ensures fast remote-controlled operation. A combination of S800PV-S MCB and the remote switching unit replaces three things: Fuses, switch disconnectors and “the electrician’s thumb”

Technical catalogue: 2CCC413002C0204



Protection

Uncompromising safety and comfort

S200 / S200M: the next MCB generation within the proved System pro M compact®

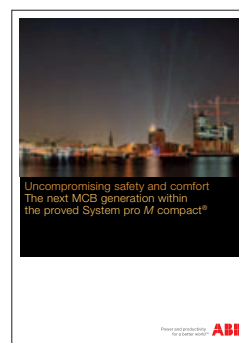

A range designed to ensure efficiency and protection: our MCBs are advanced for more than 120 years in the history and mindset of the inventor Hugo Stotz. Today we offer feasible MCB solutions for all kind of applications, which are developed in close touch to market requirements from various branches. Numerous patents have been made during this time and ensure our market position as the “original” and innovation leader.

Brochure: 2CDC002107L0202



Protection

A real all-rounder!

The innovative S200MUC:
flexible control of both AC
and DC

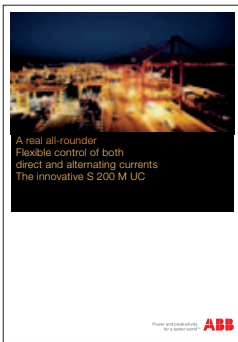

The S 200 M UC impresses with its performance range and high number of approvals. Moreover, its flexible application for both AC and DC makes it a valuable addition to the System pro M compact® range. Whether warehousing and project engineering, planning and installation or maintaining equipment, the S 200 M UC is an easy to use and flexible solution.

Flyer: 2CDC002140L0201



All DIN Rail functions

International System pro M compact® catalogue - edition 2012

DIN Rail components for
low voltage installation



For all applications in residential, industrial and commercial installations ABB System pro M compact® range offers many functionalities like:

- protection and switching
- checking and monitoring
- control and programming

The System pro M compact® range offers enormous advantages in relation to installation. Advanced and smart solutions allow a far easier and safer installation and guarantee time saving.

Technical catalogue: 2CSC400002D0210



Software

RD3 demo software

Electronic residual current
relays



In the SW you will find application examples and all the product information.

In each product page you can find:

- Assembling instructions
- Wiring instructions
- Technical sheet
- Instruction manual
- Demo

With this SW you will be able to learn and simulate all the functions of the RD3 range.

Software: 2CSC444023E5101



Electricity Meters

EQ meters C11 Easy and compact

One module single phase meter up to 40 A

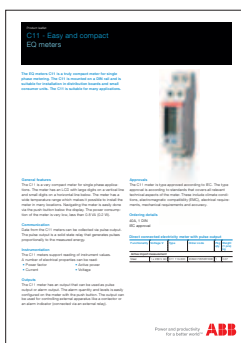

The C11 is a truly compact DIN rail meter for single phase metering.

- Only one module wide
- Up to 40 A
- See P, A, V, Pf direct on the display
- Pulse output or alarm

The C11 is suitable for many application.

Leaflet: 2CMC486001L0201



Protection

OVR NE12 and OVR T2 U range catalogue

SPDs with UL 1449 3rd edition certification

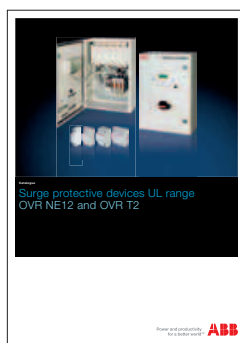

For all installation requiring a surge protection which comply with the latest UL certification:

- Service entrance and distribution board location
- OVR NE12 enclosed unit with 6 references and 3 service voltage
- OVR T2 U range for DIN rail installation

The OVR UL range offer a complete solution for surge protection.

Brochure: 1TXH000168C0201



Protection

OVR PV brochure

Specific SPDs for photovoltaic installations

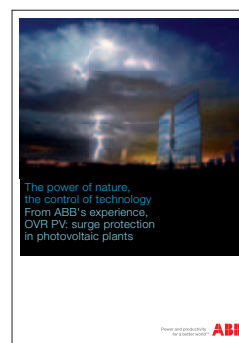

For all photovoltaic installations on 600V and 1000V DC solar networks:

- Type 1 and Type 2 devices
- Specific disconnection for a safe protection

The OVR PV range offer a complete solution for surge protection on photovoltaic networks.

Brochure: 2CSC432012B0301



Measurement

Current Measurement System (CMS)

A new level of efficiency and availability



Branch-circuit monitoring with the CMS offers a new and easy way to gain transparency over current consumption in branch circuits. This brochure contains the necessary information about the product benefits, application examples and a system description.

Brochure: 2CCC481002B0201



Command

D 365 Infinite possibilities

All on time



D Line range is enlarging thanks to the new yearly timer switch D 365. D 365 meets the continuous demands of dedicated automation systems, in both the residential and tertiary sectors. Discover all the technical features and communication protocol available in the dedicated Product Note D 365.

Product Note: 2CSC440024B0201



Hospital segment

ABB technology and safety in hospitals

Products, solutions, management and control

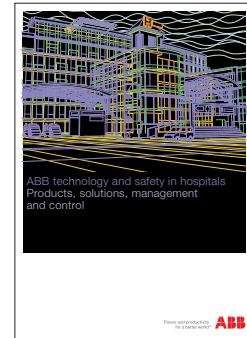

The brochure provides an overview over ABB low voltage products which are specifically intended for hospitals. The main requirements in such environment are operational continuity of the supply, smart and efficient energy consumption. ABB solutions H+Line, Smisline and KNX allow you to use the operating theaters with maximum safety, easy maintenance and better monitoring of energy consumption, providing maximum comfort for patients and people. In the document many references of projects that ABB has carried out all across Europe are reported.

Brochure: 2CSC470050B0201



Intelligent Building Control

E-Learning modules for ABB i-bus® building control

Leadership through knowledge



To supplement its tried and tested schedule for on-site training, ABB now also offers brand-new, free e-learning modules on the Internet. The compact lessons provide learners with relevant knowledge on products and facts related to ABB i-bus Intelligent Building Control: they can be used by everyone who is interested in the topic, but also to refresh and reinforce existing knowledge.

Currently e-learning modules are available for the DALI Light Controller DLR/S, the Blind/Roller Shutter Actuators JRA/S, the ABB i-bus KNX Security Terminals, Room Master 1.1 & 2.1, Energy Actuator SE/S and HVAC solutions with KNX. The list is continuously updated and new items are added.



Smartphone Apps

CT Wizard



CT Wizard is an APP to easily select CT series current transformers in few simple steps wherever you are. CT Wizard helps you to select ABB codes for CT and for all the applications: industrial, residential and commercial buildings. In few taps CT Wizard can provide you the right code, listing you technical characteristics and documentation links.

Smartphone Apps

DS Wizard



DS Wizard is an APP to easily select the RCBO in few simple steps wherever you are. DS Wizard helps you to select ABB codes for DS201 and DS202C series for residential, commercial or industrial application. In few taps DS Wizard can provide you the right code, listing you technical characteristics and documentation links.

Smartphone Apps

OVR Wizard



OVR Wizard is an APP to easily select surge protective devices (SPD) in few simple steps wherever you are. OVR Wizard helps you to select ABB codes for OVR series for all the applications: industrial, residential, commercial buildings and photovoltaic. For each selection OVR wizard will provide also the backup protection type. In few taps OVR Wizard can provide you the right code, listing you technical characteristics and documentation links.

Smartphone Apps

T Wizard



T Wizard is an APP to easily select transformers in few simple steps wherever you are. T Wizard helps you to select ABB codes for TI, TM and TS series for all the applications: bell transformer, control, safety and isolating transformer and Insulating transformers for medical locations. In few taps Wizard can provide you the right code, listing you technical characteristics and documentation links.

Top six

Six solutions to ensure the system operational continuity for more comfort in your home and higher productivity in the workplace.

OVR

Surge protective devices



Overvoltages not only cause damage to electric apparatus but are also often sources of unwanted tripping of residual current protections. A surge protective device installed upstream an RCD is a valid solution to not being left in the dark during a storm.

LSS1/2

Load management switch



Exceeding the maximum contractual power may cause the intervention of the utility meter. The consequence is the interruption of the power supply of the entire system which can only be reset manually by the switch. To avoid the unwanted power disconnection, distribute the power optimally. The LSS1/2 switch manages a maximum of three groups of single-phase loads, with different priorities, up to 90 A of total absorption. When the preset threshold is exceeded LSS1/2 disconnects the non-priority loads, thereby avoiding the maximum power available being exceeded.

ISL

Insulation monitoring device



In critical applications it is absolutely necessary to ensure power supply continuity and the functioning of the devices. ISL insulation monitoring devices ensure continuous control, locating any dangerous dispersions that could endanger operational continuity and the efficiency of the system. This enables you to remain informed in real time on the system insulation status and to actuate the correct scheduled maintenance policy. The ISL range is available for AC and DC networks up to 600 V and for voltageless networks up to 760 V.

ATT

Remote monitoring and commanding of loads



ATT modules are GSM actuators that ensure the remote controlled supervision of electric utilities through a mobile phone in both a residential and an industrial environment. This makes it possible to receive information on the system in real time, directly on your own PC or mobile phone, control electric loads and remotely react in case of a fault or malfunction. The ATT range is supplied with ATT-Tool, the software which allows the device to be programmed.

F2C-ARH

Autoreclosing device



Greenlight F2C-ARH is an autoreclosing device for DIN rail. It can be installed in every residential application and is compatible with two poles RCCBs 30 mA of the F200 range up to 63A. Before reclosing, the device automatically controls the insulation and recloses the residual current circuit breaker in less than three seconds; in the event of an earth fault, the device goes into a state of lock and its signalling contact switches, providing a useful indication of the condition.

APR

Anti-perturbation RCBO



Used to protect from the effects of sine wave and direct pulsating earth fault currents, they represent the best choice to assure operational continuity thanks to their resistance against unwanted tripping. The APR are designed to withstand atmospheric surges and overvoltages.

Good morning DIN rail

ABB answers to some of the many questions posted to our experts through email. Send your technical questions to mail.daybydin@abb.com, the most interesting ones will be published and answered on next issues of Day by DIN.

Is it possible to feed the LED of an E210 luminous push button with a different voltage from the one used in the controlled circuit?

The cabling of this type of product allows it to be independently wired to the push button and the LED. For example, it is possible to use the pushbutton in a 230 V AC circuit and, by choosing the suitable version of indicator light, connect the LED to a 24 V DC power supply. The LEDs, as a matter of fact, are multivoltage and can be fed with 12-48 V AC/DC, 115-250 V AC and 110-220 V DC. The possibility to double feed allows the status of the piece of equipment to be visualized independently from the presence of voltage in the pushbutton.

What is the ideal solution for supplying operating theatres and areas for group 2 medical locations?

In order to satisfy the needs of group 2 medical locations, ABB supplies pre-assembled wall-mounted and floor standing QSO electrical switchboards, complete with transformer and ISOLTESTER-DIG-RZ insulation monitoring device to detect and signal promptly the first fault to earth. The new QSO operating theatre switchboards are the ideal solution to supply operating theatres according to the IEC 60364-7-710 reference standard, to assure patient and medical staff safety in intensive care units, operating theatres, emergency rooms, doctors surgeries, day hospital premises, nursing homes, dental clinics and pets surgeries.

Is a Declaration of conformity necessary for hospital switchboards?

All QSO switchboards are wired by ABB, and are equipped with the declaration of



Francesca Sassi
Product Marketing Manager
DIN Rail Products

conformity which is necessary for the system initial start up, aiding the installer with setting up the system and safeguarding the work.

Is it possible to receive the test report related to the medical insulating transformer according to the IEC 60364-7-710 reference standard?

Certainly. It's enough to communicate the serial number indicated on the plate of QSO switchboards to your referent ABB Area Sales Manager.

Are the certificates included in the QSO switchboard documentation?

No, since the tests must be carried out in the factory on each unit produced, as required by the standard. To speed up delivery times, the certificates are sent separately and only upon request from the customer.



Send us your questions:
mail.daybydin@abb.com



CMS Current Measurement System. A new level of efficiency and availability.

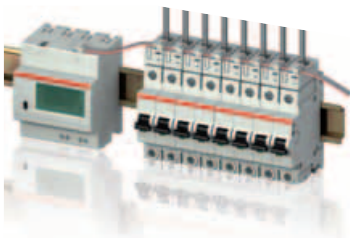

To minimize energy and downtime costs, the CMS offers an unique and highly efficient branch monitoring solution. The ultra-compact CMS sensors can be easily integrated in existing and new installations within power distribution units. This provides an unprecedented transparency of the consumption which increases the energy efficiency and service continuity of the plants. www.abb.com/lowvoltage



Insulation monitoring

Operational continuity thanks to
IT distribution systems

Francesca Sassi: Product Marketing Manager - DIN Rail Products





01

- 01 The protection of the direct and indirect contacts is fundamental for ensuring operational continuity.
- 02 ISOLTESTER is the insulation monitoring device specifically for group 2 medical locations
- 03 ISL insulation monitoring devices allow the prompt detection of loss of insulation in the cases in which it is necessary to guarantee a continuous power supply even in the presence of a first earth fault.

To ensure the continuous operation of electrical equipment, Standard IEC HD 60364, “Electrical equipment using a nominal voltage less than 1,000 V in alternating current and 1,500 V in direct current”, imposes the obligation of protecting the equipment from direct and indirect contacts.

Means of protection

Out of all the means of protection singled out by the Standard, only IT distribution systems can guarantee an increased operational continuity in the case of a first earth fault: as a matter of fact, in these systems, the circuit breaker does not intervene, since the fault current is limited by the high insulation impedance.

The IT distribution systems are therefore used where the operational continuity is a fundamental requirement, to avoid the risks that an interruption of the power supply would carry.

Operational continuity in a hospital location

In operating rooms and all group 2 medical locations, the presence of supply is an essential condition for feeding medical appliances and devices on which the patient's life depends. In these contexts it is mandatory to install an IT-M system that guarantees operational continuity over medical activities even in the case of a first earth fault. The IT-M system is an electrical IT distribution system, in which the letter M stands for the specific application in the medical sector.

This system is prescribed by Standard IEC HD 60364-7-710, that states the characteristics that the electrical distribution

equipment needs to have relative to their particular uses (Section 7) and that medical locations have to comply (710).

The IT-M system is fed by a specific isolating transformer for medical use that has a permanent insulation control device as prescribed by Standard IEC 61557-8.

The IT-M operating principle is based on the fact that the circuit fed by the secondary of the insulation transformer is galvanically separate so, at the appearance of a first earth fault due to a defect of equipment insulation, the current has no option but to continue to flow through the phase conductors. In this situation, the result is that all the electromedical devices keep on working.

The IT-M system is not mandatory, but recommended in group 0 and 1 locations, while in group 2 locations it is mandatory in the patient environment, for the sockets and plugs and for fixed handheld appliances.

The first earth fault must however be eliminated immediately, since a second earth fault would cause the tripping of the protective devices (thermomagnetic switches), causing an interruption of the power supply.

The Standard deems necessary, therefore, the obligation of installing an insulation monitor to signal the insurgence of the first earth fault, in such a way as to intervene promptly, before a further fault interrupts the necessary continuous operation of the equipment.

Operational continuity in an industrial environment

Even in an industrial and commercial environment the operational continuity can be a fundamental requirement, where



02

Glossary

Insulation resistance:

Is the resistance value of the IT circuit in relation to earth. During normal operation it is very high (even Mohms), precisely because the IT system is isolated from earth. A low insulation resistance value is, on the contrary, an indication of a dispersion to earth due to a fault. In Group 2 medical locations, Standard IEC HD 60364-7-710 assumes there is a fault when the insulation resistance drops below the 50 kohm threshold.

IT System:

An electrical system in which neutral is insulated or earthed via appropriate value impedance (a few hundred ohm in 230÷400 V plants) and the metallic masses are joined, separately or collectively, to an earthing system that is shared or separate from that to which the neutral might be connected.

Insulation monitoring device:

Device able to signal the first earth fault, to prevent the intervention of

the protection devices to interrupt the necessary continuous operation of the plant.

Group 2 medical locations:

Medical locations where electromedical devices are used with applied parts destined to be used in intracardiac surgery, surgical operations, or where the patient is subjected to vital treatment where the absence of a power supply could be life threatening.

the interruption of the power supply can cause huge damage to production or each time it is not possible to suspend service for the client to carry out maintenance or repairs when faced with plant failure. This is the case with large processing or telecommunication plants, or photovoltaic plants. In these cases too, one would turn to an insulated neutral IT plant controlled by an appropriate ISL insulation monitor.

Thanks to the experience gained in critical applications such as those of hospitals, ABB has developed the new range of ISL insulation monitors destined for electrical IT plants, which conform to the current Standards IEC HD 60364, also for use in photovoltaic, industrial and commercial environments.

Appliances that allow the prompt detection of insulation loss, when it is necessary to guarantee a continuous power supply even in the presence of a first earth fault.

The ISL range features three families of devices:

- an insulation monitor for direct current (ISL-A);
- for alternating current (ISL-C);
- for networks out of voltage (ISL-MOT).

The first consists of four models, for line control from 24 to 600 V DC The second is suited to lines from 24 to 760 V AC, while the ISL-MOT version deals with the control of lines up to 700 V AC/DC. All the models in the range have basic signalling for correct functioning and warning in case minimum insulation resistance threshold is overtaken (TRIP

output contact). Moreover, the devices have a pre-alarm threshold (ALARM), with a change-over contact, and remote programmable Test and Reset functions. All these technical characteristics contribute to a greater plant efficiency and a knocking down of maintenance and inefficiency costs.

The ISL range is suited to line protection and/or systems in different fields of application, amongst which the main ones are: chemical and metallurgical industries, photovoltaic plants, fire pumps, UPS, mobile units, film sets, TV and radio structures, data centres, emergency lighting.

The installation, made easy by the compact dimensions (3 or 6 modules as models), is quick and easy, with a rapid 35 mm DIN rail terminal.

Thanks to the experience gained in critical applications such as those of hospitals, ABB has developed the new range of ISL insulation monitors made for electrical IT plants.



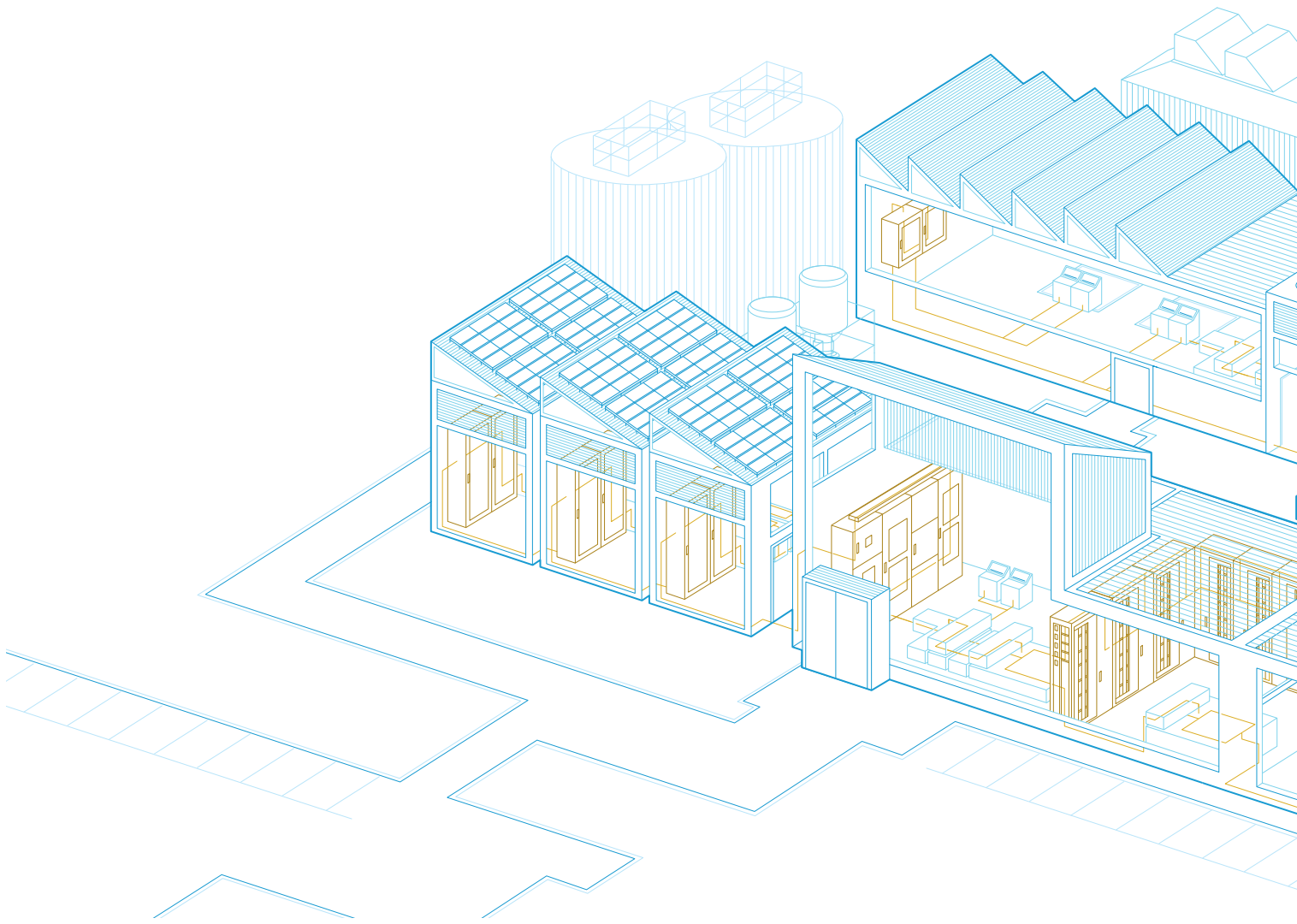

IEC 61439

The new standard for low-voltage switchgear and controlgear ASSEMBLIES

Cristian Dell'Anna: *Product Manager - Enclosures*

Dear reader, following we are pleased to present the second and last part of the article that we have introduced with the previous number of Day-by-Din. In particular we will try to summarize what are the Responsibilities stated by the new Standard and as well, in the FAQ section, we'll try to anticipate the most common questions that the introduction of the new Standard may generate between all the "actors".

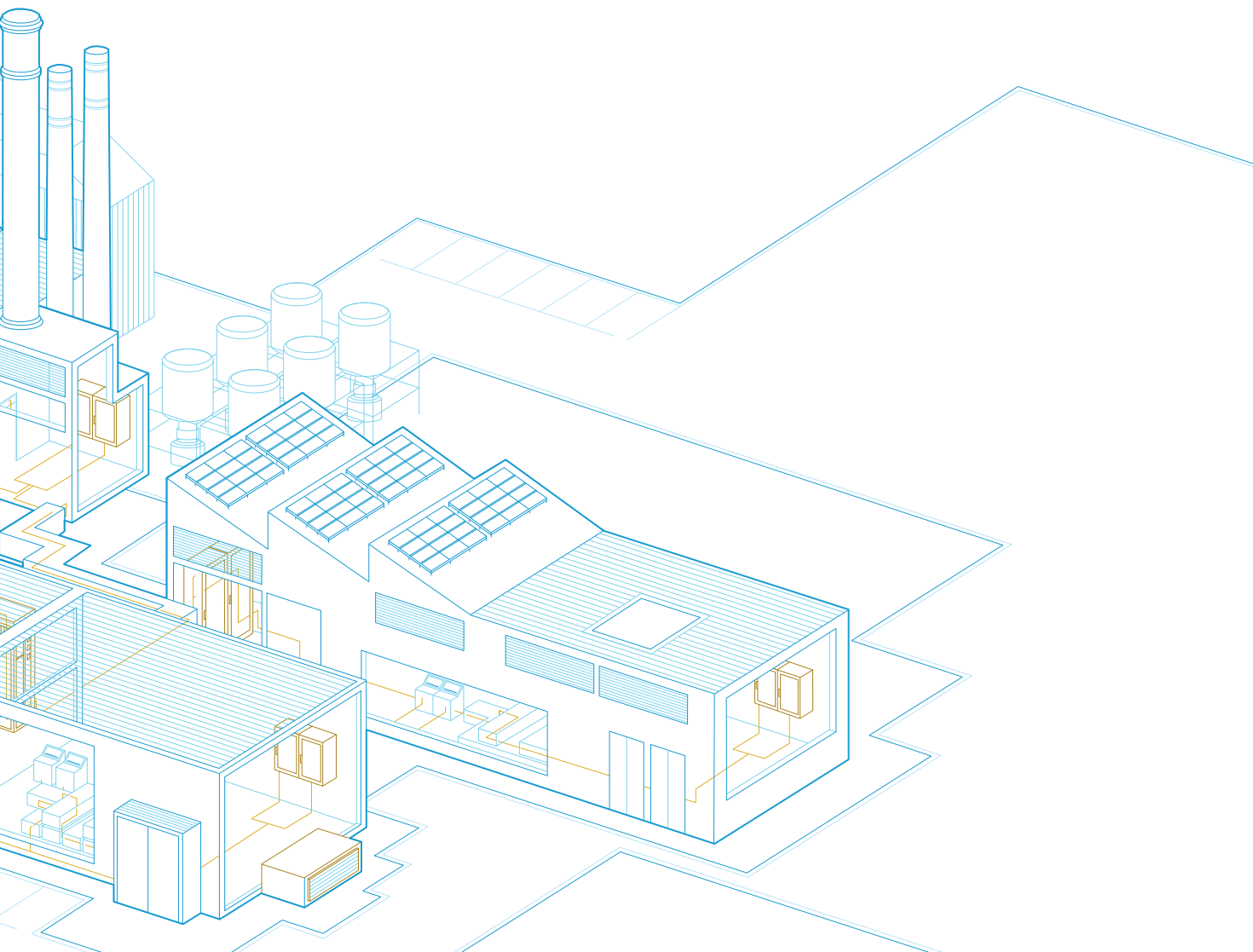

Responsibilities

With regard to responsibilities, the general and obvious rule is: the manufacturer of the ASSEMBLY is responsible for the ASSEMBLY!

For a better explanation of this concept we can say: the Original Manufacturer usually makes design verifications and assumes responsibility for the proper functionality of prototype ASSEMBLIES. He provides a portfolio of verified ASSEMBLIES and each “actor” in the electrical market, who becomes the ASSEMBLY Manufacturer, can manufacture a design verified ASSEMBLY by following the instructions supplied in the Original Manufacturer’s instruction manual or catalogue; the ASSEMBLY Manufacturer assumes responsibility for the ASSEMBLY, he labels the ASSEMBLY and it is his responsibility to declare that the ASSEMBLY complies with the relevant standards.

In practice he has two options:

- he decides to manufacture the ASSEMBLY according to the rules of the Original Manufacturer. In this case, the ASSEMBLY Manufacturer has to perform only the second stage verification, namely routine verification.
- he decides NOT to manufacture the ASSEMBLY according to the rules of the Original Manufacturer. In this case, the ASSEMBLY Manufacturer incorporates his own arrangements, so that he is deemed to be the Original Manufacturer. Regarding these arrangements and he must then carry out both the first and the second stage verification: design verification and routine verification.

Some hypothetical examples

An Original Manufacturer (e.g. ABB) assembles a complete ASSEMBLY and sells it to a panel builder

- the panel builder is only the ASSEMBLY Manufacturer, if he installs the ASSEMBLY as it is.

- the panel builder is the ASSEMBLY Manufacturer and becomes the Original Manufacturer if he makes some modifications to the ASSEMBLY.

A panel builder assembles a complete ASSEMBLY (according to the rules of the Original manufacturer)

- the panelbuilder is the ASSEMBLY Manufacturer and is responsible for the ASSEMBLY, providing the electrical installer installs the ASSEMBLY without making any alterations.

A panel builder assembles a complete ASSEMBLY (according to the rules of the Original manufacturer) that has been partially assembled by an external supplier

- the panel builder is the ASSEMBLY Manufacturer and is responsible for the ASSEMBLY.



Cristian Dell'Anna
Product Manager - Enclosures

FAQ

Until what point is it possible to manufacture and to install ASSEMBLIES in accordance with IEC 60439?

The validity of the two standards will overlap until 2014 and prior to this date, ASSEMBLIES can be manufactured according to IEC 61439 or IEC 60439.

If tests on the ASSEMBLY have been conducted in accordance with IEC 60439, is it necessary to repeat them in accordance with the new IEC 61439?

No, if the conducted test results fulfil the requirements of the new IEC 61439 it is not necessary to repeat them. It is necessary to test only the additional verification that has been introduced by the new standard.

Is it possible to manufacture an ASSEMBLY in accordance with the new IEC 61439, with enclosures from ABB, busbars from another manufacturer, circuit breakers from another manufacturer, etc.?

Yes, it is possible but it is not easy and it is expensive. The panel builder that decides to mix different "elements" from different manufacturers is not only the

ASSEMBLY Manufacturer, but becomes the Original Manufacturer and has to perform both the first and the second stage verification: design verification and routine verification. The routine verification is similar to the present routine test and is relatively straightforward. The design verification however includes some characteristics which are easily verified, and others that can only be verified through laboratory testing.

What is the Rated Diversity Factor (RDF)?

The RDF is the per unit value of the rated current, to which outgoing circuits of an ASSEMBLY can be continuously and simultaneously loaded (the mutual thermal influences have to be taken into account). It can be declared for groups of circuits or for the whole ASSEMBLY. The RDF has to be assigned by the ASSEMBLY Manufacturer (if not specified it is assumed to be equal to 1). In practice it is recognised that not all circuits in an ASSEMBLY operate at rated current continuously and this allows efficient use of materials and resources.

Flow chart to establish how to verify the temperature rise

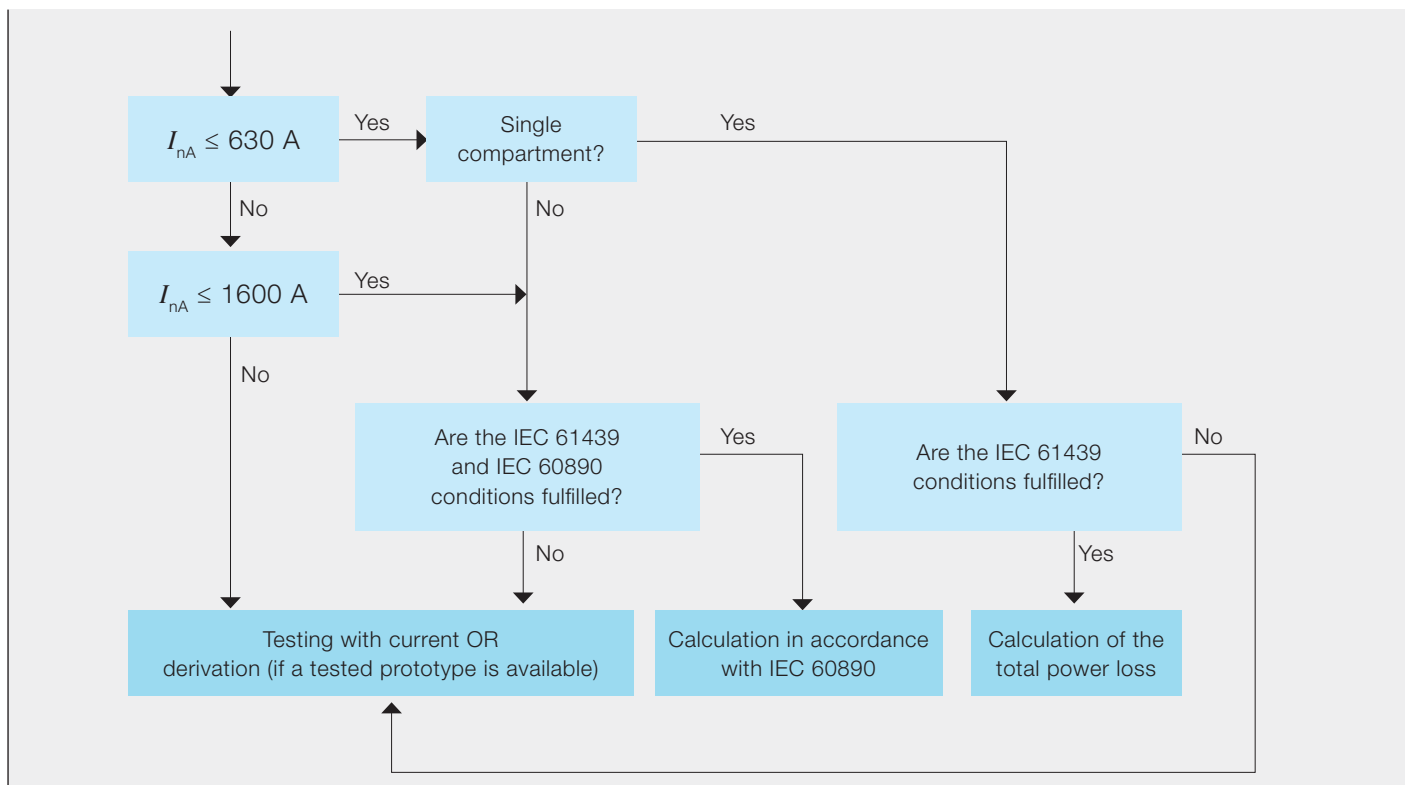

Is it possible to substitute a device within an ASSEMBLY? What about temperature rise and short circuit strength?

The new IEC 61439 clearly defines a device substitution in respect of temperature rise and short circuit strength. Temperature rise: it is possible to substitute a device without repeating the design verification, provided that the new device from the same or another series has identical or better values, regarding power loss and terminal temperature rise, in comparison with those of the original device, as tested in accordance with the product standard. Short circuit: it is possible to substitute a device without repeating the design verification, provided that the new device is identical. If different, it has to be from the same manufacturer who has to certify that it is equivalent or better with regard to all relevant short circuit characteristics.

Is the verification of the short circuit withstand strength required for all circuits of an ASSEMBLY?

No, it is not required for:

- An ASSEMBLY having a rated short-time withstand current or rated conditional short circuit current not exceeding 10 kA r.m.s.
- An ASSEMBLY protected by current-limiting devices having a cut-off current not exceeding 17 kA at the maximum permitted prospective short-circuit current at the terminals of the incoming circuit of the ASSEMBLY.
- Auxillary circuits of an ASSEMBLY intended to be connected to transformers whose rated power does not exceed 10 kVA for a rated secondary voltage of not less than 110 V, or 1.6 kVA for a rated secondary voltage less than 110 V, and whose short circuit impedance is not less than 4%.

All other circuits have to be verified

Does the verification of temperature rise remain unchanged?

Temperature rise requirements have been explained in further detail. Three different methods are now allowed for verification (the Original Manufacturer is responsible for choosing the suitable verification methods):

1) Testing with current:

Three different test methods are permitted and the Original Manufacturer has to determine the best method. When a number of variants of an ASSEMBLY have to be verified, the most onerous configuration has to be tested and the ratings of the less onerous (and similar) variants can be derived without testing.

2) Derivation (from a tested design):

The standard defines a series of sub-clauses that help to define how non-tested variants can be verified by derivation from similar arrangements verified by test.

3) Calculation

Two calculation methods are allowed:

- Single compartment ASSEMBLY with rated current not exceeding 630 A (done by calculating the total power loss of the ASSEMBLY if certain conditions are fulfilled).
- Multiple compartment ASSEMBLY with rated current not exceeding 1600 A (done by calculation in accordance with the method of IEC 60890 if certain conditions are fulfilled).

Summary and conclusion

The new standard IEC 61439 introduces important modifications in comparison with the current standard IEC 60439 on low-voltage switchgear and controlgear ASSEMBLIES.

The structure of the new standard is clearer with a general part and product specific parts. New definitions have been written (e.g. "Original Manufacturer" and "ASSEMBLY Manufacturer"). New compulsory characteristics have to be specified (e.g. rated current of the ASSEMBLY).

A new "design verified ASSEMBLY" concept has been specified. This new concept completely discards the categories TTA and PTTA, and the compliance of an ASSEMBLY can now not only be verified by means of tests, but also with alternative methods: calculation/measurement and design rules.

The new standard is more precise, eradicating the "grey" areas contained in the previous standard. The responsibilities for an ASSEMBLY are clearly defined, making the job of each "actor" on the electrical market easier nowadays.



If you switch off an electronic device using only the remote control, a small part of its electronics remains on, waiting for a signal. Did you ever ask yourself how much it costs to keep our devices on stand-by?

Aron Svedin: *Product Marketing Manager - DIN Rail Products*

Dear stand-by, how much you are costing me...

For several years now, electronic devices for domestic use have been designed to function in three ways: on, off and on stand-by. This third mode allows a television or a decoder to remain off but to be switched on again with the simple touch of a remote control button. At a technical level, stand-by is an electronic circuit which remains in function waiting for a signal: it is as if the television was sleeping with one eye closed and one eye open.

How much does stand-by cost the citizen and the environment?

Household appliances use a small amount of energy even on stand-by, i.e. when they are not switched on. The red light which remains illuminated on the device is the standard indicator of this state. All devices equipped with a remote control such as televisions, DVD players, decoders and Hi Fi's have stand-by mode. Other electrical appliances, even though not equipped with a remote control, sometimes do not have an off switch: video game consoles, computers, etc.; these do never sleep either. All of the devices in which a display or a red/green LED remains on can use up to 20 W or more each time they are left on stand-by.

Let's try and calculate: five devices on stand-by in a living room, most of which are not of the latest generation, 22 hours a day, 365 days a year, with an average cost of 15 cents per kWh. In one year our restless energy consumers result in a bill of approximately 60 euro:

$$0.01 \text{ [kW]} \times 5 \text{ [devices]} \times 22 \text{ [hours]} \\ \times 365 \text{ [days]} \times 0.15 \text{ [euro]} = 60.2 \text{ [euro]}$$

Quite an expense - with which we could pay for a beautiful Christmas present, half an installment on the car, a fast food dinner, three months of pay TV subscription or something else - especially if we consider the fact that we are spending all that money in order to keep the devices off!

If there are more devices or older devices the annual cost of stand-by could be even higher, easily reaching € 150 per year. And we are only talking about the living room!

If we look at the environment, then the cost is even higher: many studies which have been carried out in developed countries from Italy to Australia, from Japan to the United States have documented that stand-by alone accounts for approximately 10% of domestic consumption.

In the United States alone domestic devices kept on stand-by use 64 MWh, the entire production of approximately 18 medium sized electric power stations. It is a global problem with a world wide impact which, as is often the case, can be resolved with the commitment of each one of us.

In our own little way... we too can do something

Reducing the economic and environmental effects of stand-by does not only mean decreasing the consumption of appliances, something which International Bodies and consumer electronics manufacturers are working on, but also changing the habits of the end user: to solve this problem we have come up with a solution to ensure that the system's consumer panel switches off all the appliances on stand-by. In this way, not only can the user save a fair amount of money each year, but we also protect your appliances from storms, short circuits or premature ageing.

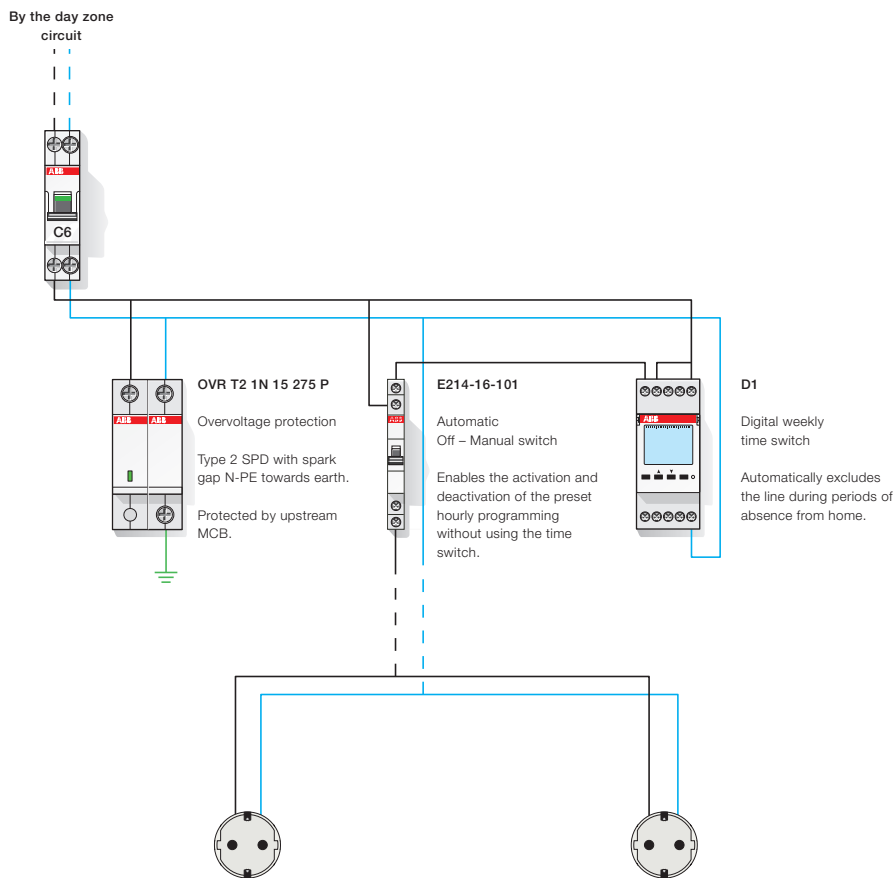

01

A plant design solution which allows the consumer unit to switch off all of the devices in standby.

Downstream from the “day zone power” we have placed a dedicated MCB, as shown in figure 1, which exclusively powers the outlets to which all of the appliances which have a stand-by function are connected. Considering the low overall use of power, a 6 A device can be sufficient.

After the switch we have inserted a SPD: electronic appliances are not only energy consumers but also very delicate and expensive. Dedicated protection against overvoltage is fundamental in preserving operation and preventing faults for years.

The dedicated line is then managed through a three position switch and a digital time switch. The clock enables the switching on and off to be programmed automatically, freeing the user from the need to remember to switch off the appliances when not in use for long periods of time. For example, if nobody is at home on weekdays, from 9am to 6pm the sockets are without power.

The three position switch enables the user to manage the exceptions to the rule:

- **AUTO:** The system is automatic and follows the clock programming;
- **MANUAL:** the user can manually force the turning on of a group of sockets because, for example, Wednesday is not always a workday.
- **OFF:** the user can manually force the turning off of a group of sockets, for example, prior to going on holiday or spending a weekend away from home.

System optimisation

As regards to the sockets that supply televisions and correlated appliances, a number of installation details ensure the user a higher level of comfort.

First of all, a higher number of sockets is foreseen: not only do the TV, decoder, console, DVD, stereo, computer need to be powered, but also accessories such as printers, Wi Fi routers, repeaters and TV and satellite amplifiers, adapters which we often forget about.



Glossary

Stand-by

Operating mode of an electronic apparatus characterised by a number of circuits being maintained in function for the immediate start of the apparatus through the reception of a signal from the remote control. This state is generally highlighted by a LED.

SPD

Surge Protective Device, definition of the surge arrester according to International standards.

Then, supply adequate space between one socket and another: manufacturers are increasingly using power supply units with an incorporated plug which are almost impossible to install one next to the other. Thanks to these details, we save the user from those flying cables made of adapters, multi-plug adapters, reducers which are awkward and may be dangerous if not installed correctly.

To sum up, approximately 6 DIN modules and about ten minutes work are needed to realize the 'no stand-by' line to power the group of sockets: given the annual cost of stand-by, it is highly likely that the user makes back the investment in a very short period of time.

The environment and your wallet will take the benefits!



Aron Svedin
Product Marketing Manager
DIN Rail Products

Seen from within! The hidden aspect of everyday devices

How many times have you installed a modular product and asked yourself... What is it like inside? How does it work? ABB has decided to satisfy your curiosity by disassembling the most curious and mysterious devices for you. Let's start with Type 1 SPD!

Christophe Rios: *Product Marketing Manager - Modular Devices*

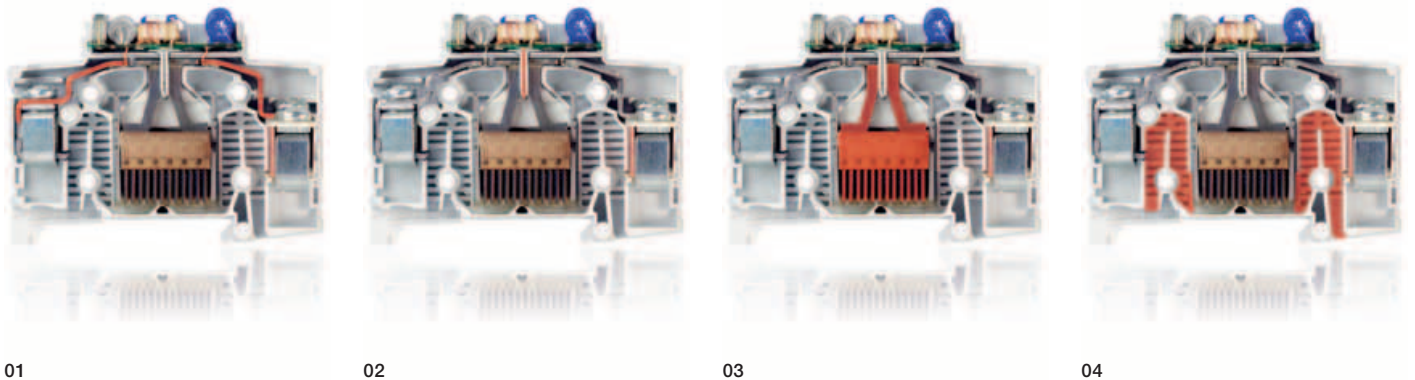

Surge protective devices

ABB class 1 SPD are voltage switching type devices in conformity with Standard EN 61643-11.

The working curve of this kind of device may be represented as you can see in the chart aside.

As seen in the figure, when an overvoltage takes place, when a certain value is reached - the sparkover value - the voltage at the top of the module suddenly collapses to a few volts, corresponding to the single arc voltage.

It is evident that the quicker the sparkover process, the more the maximum value reached by the voltage at the top of the SPD will be reduced and the less the electrical apparatus connected downstream will be stressed.

ABB Class 1 SPDs incorporate a sophisticated electronic control that facilitates the "ignition" of the arc, ensuring an optimal level of protection of the SPD. Thanks, moreover, to an arc extinction room, not present in the traditional spark gaps, the SPD is able to interrupt the subsequent short circuit up to 50 kA as well.

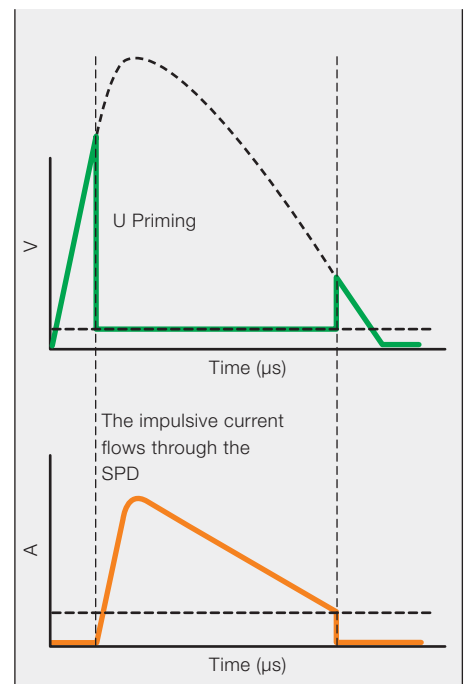

- 01 The discharge reaches the terminals of the SPD and is detected by the electronic device.
- 02 Thanks to the active intervention of the electronic device, the electric arc is switched on in advance.
- 03 The electric arc runs on the electrodes and is directed into the arc chamber to be extinguished.
- 04 The hot ionized gas flows in the suitable cooling conduits, preventing the risk of fire.





Faster mounting, the safe way. Tool-free Easy Connect Technology.

Easy, safe and fast. Thanks to the tool-free screwless terminal technology the S 200 S can be wired far more quickly and easily than standard screw-type circuit breakers. All kinds of cables can be connected. Rigid cables and flexible cables with end sleeves can be plugged in the screwless terminal directly. The easy-to-use, smooth-running terminal lever only needs to be pushed to connect flexible cables without end sleeves or to disconnect the wiring. What's more, they are fully compatible with all ABB pro M compact® system components and allow other devices such as miniature circuit breaker, all available accessories and residual current protective devices to be combined effortlessly. www.abb.com/lowvoltage

Doktor Wise

The expert answers

In this section an ABB expert answers to the most frequently asked questions regarding the use of low voltage distribution products, to solve problems and propose the most suitable solutions for every application.

In this number, besides from some of the most frequently asked questions regarding the ABB time and twilight switches, a useful glossary for the terms most commonly used in the field is provided.

Francesca Sassi: *Product Marketing Manager - DIN Rail Products*

When is it best to use a digital timer instead of an electromechanical one?

The digital time switches are more accurate, have smaller switching time and many more programming functions (impulsive, cyclical, random, holiday, etc) in regard to the analog time switches. Moreover, the absence of mechanical parts in motion ensures longer running reserve (years, instead of hours). In all the applications, when the operations are

numerous, frequent and diverse (daily, weekly or yearly), the time switches of the D or DTS lines allow for better performances with a small difference in price.

Is it possible to connect more than one sensor with twilight models TW1 and TW2/10K?

No, one sensor must be always used for every device.

The permanent OFF position is not available for the 1 channel model. How can this be realised?

The permanent OFF is used for maintenance or holiday period operations. In both cases the load can be permanently disconnected by disconnecting the upstream protection or by installing a E214 group switch (0,5 modules) in parallel.

Glossary

Analog

Electromechanical time switch, programmable moving the position of the captive segments and synchronised with quartz or through the mains frequency

Digital

Electronic time switch, equipped with LCD display and any programming key for the exchange of the programs

Daily

Periodic programming of 24 hours

Hourly time

Periodic programming of 1 hour

Weekly

Periodic programming for 7 days

Annual

Periodic programming of one or many years

Running reserve

Interval of time during which a time switch can work normally, without supply voltage from the mains network, thanks to an embedded backup battery

Minimum switching time

The shortest time between an ON-OFF cycle

Captive segments

Small sliding mechanical segments, generally arranged in a circle on a frontal metal ring of an electro-mechanical time switch; their width represents the minimal time of commutation

Impulse program

Programming function at very low switching time

Cyclic program

Programming function for a periodic commutation of the load

Lux

This is the measuring unit for the illuminance

DCF77

Marks the official German time, transmitted in permanent mode from Mainflingen, in Germany (500° 01 ' N, 09° 00 ' E) with 50 kW of power. The signal has a reception range of approximately 2500 km and a precision that reaches 1 second every 300,000 years

GPS

The Global Positioning System (GPS) is a positioning system based on satellites for a total global and continuous cover, managed from the American Department of Defense.



01

02

When does the astronomic timer find its application?

When the length of the connection between the device and the sensor is more than 100 m, or when the connection is too complicated (for example, panel installed in cellar).

When it is impossible to install the sensor at some distance from the light sources (amusement park, camping grounds, etc.)

When external agents compromise the correct functioning of the sensor as, for example, pollution or vandalism.

Is it possible to connect different types of sensors with the TW1 or TW2/10K models?

No, the only sensor allowed is the LS-SP type.

- 01 The DTS year digital time switches
- 02 TW twilight switches and external LS-SP sensor

The GPS system combines the time supplied from various atomic clocks installed on the edge of satellites, whilst a net of terrestrial stations determines and corrects the errors. Since the time is obtained from various sources at the same time, the clock can automatically compensate the propagation delays and other problems, arriving at an accuracy lower than one second

Astronomic switch

Twilight or digital switch able to foresee the exact hour of the dawn and the twilight based on the data and the latitude of installation, without using an external light sensor

Intervention delay

Delay time in the commutation of a twilight switch; it allows unwanted interventions due to a fast variation of the light caused by external factors to be avoided (e.g. the headlights of a car or the shadow of a cloud)

Hysteresis

Interval between the intensity values of the light which cause the switching ON and OFF avoids a possible oscillation of the commutation at dawn or sunset

EEPROM memory

Electronic memory device, programmable, non-volatile, used to preserve the hour and date settings even in case of absence of network power supply.

Synchronisation to the network frequency

Synchronisation system of an electromechanical time switch through the mains net frequency usually guaranteed by a contract with an utility

Let's construct the safety of extra low voltage

Francesca Sassi: *Product Marketing Manager - DIN Rail Products*





We try to render the electric circuits safer and safer thanks to the use of protections for direct and indirect contacts with remarkable benefits for the users; but we often forget that there is another much simpler and safe solution: power supply in extra low voltage.

The current is the source of the danger

When a person comes into contact with an active part, an electric current passes through, which, according to the intensity, can cause from a light sensation to serious shock. Above the following thresholds the current can be life threatening:

- 25mA in alternating current at 50Hz,
- 50mA in direct current.

These are indicative values and may vary according to the cases.

The human body and its electric resistance

The electric resistance of the human body is not comparable to any conductive element of a circuit, although its value is

enough to allow the electric current to pass through it, creating the phenomenon called electrocution. The human body is composed of approximately 70% water which, because of its dissolved salt, makes it a good conductor.

Experimental data indicate that the resistance of the human body is comprised between 1000 Ω and 5000 Ω depending on many factors, we can consider two particular values:

- The electric resistance is approximately 1000 Ω if the person has wet skin, is without shoes and is in a wet area.
- In optimal conditions, with the skin dry and in a dry location, the resistance assumes the value of approximately 5000 Ω .

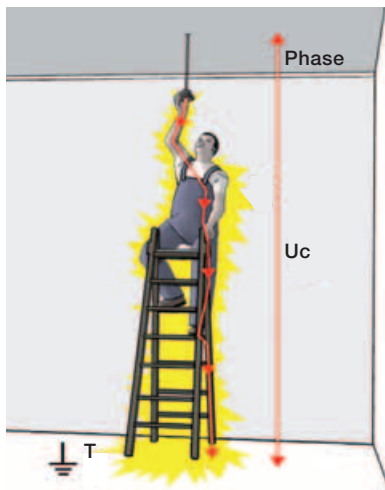

Example of direct contact

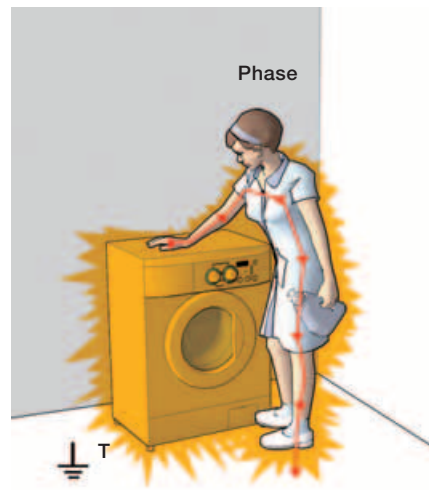

Example of indirect contact

Calculation of the dangerous voltage threshold with a resistance of 2000 Ω:

AC case	$U < 2000 \Omega \times 25 \text{ mA} = 50 \text{ V AC}$
DC case	$U < 2000 \Omega \times 50 \text{ mA} = 100 \text{ V AC}$

The law of Ohm and the safety

Based on the electric resistance of a person in a certain environment and the threshold of dangerous current, we can use the law of Ohm to calculate the maximum voltage that guarantees safety in case of contact with the active parts of a system.

The results of the calculations on this page are comparable to the indicated maximum values of voltage from standard IEC HD 60364, regarding the low safety voltage:

In alternating current: $U < 50 \text{ V AC}$

In direct current: $U < 120 \text{ V DC}$ not undulated

Using a voltage of 12 V or 24 V is, therefore, a further protection; in fact, with these voltage values the current could only become dangerous if the electric resistance of the person had a value lower than 480 Ω or 960 Ω, in the event the alternating current is lower than 240 Ω or 480 Ω in the case of direct current (respectively for 12V and 24V).

These values of resistance are only reached in very critical cases, such as wet areas (swimming pool), where, as indicated by standard, the maximum voltages are 12 V AC or 30 V DC.

The safety of persons could be assured by supplying a circuit with a voltage of 12 V or 24 V. Generally the low voltage power supplies supply these two voltages in output in alternating or direct current. At first glance the use of a low voltage transformer or power supply seems sufficient but it is not the case.

The danger can come from different parts of the system:

- If a breakdown upstream from the transformer or the supply causes the voltage to increase up to a value of several kV, the isolation between the primary and the secondary could break, carrying a very high voltage to the secondary with the consequent risks of electrocution.

The solution to avoid this problem is the use of a supply with a special isolation between the primary and the secondary.

- The earth of the system may in certain cases have a potential which is not zero. It could be that a current towards earth at another point of the system increases the potential of the device body, up to a value which is high enough to cause damage to people.

The solution to avoid this problem is not to connect the earth of the equipment in low voltage and to separate the active parts of the different circuits.

Different classes of extra low voltage

Taking into account of these two facts, the supply in low voltage is classified in three types according to the HD 60364 standard:

Starting from a FELV circuit, replacing the supply with one equipped with a special isolation, obtaining a PELV circuit. Subsequently we obtain a SELV circuit eliminating the connection between the earth and the equipment. It is not always possible to isolate the mass from the earth.

The standard indicates that the protection against direct and indirect contacts is assured for SELV voltages lower than 25 V AC and 60 V DC the SELV circuit is therefore the safest solution.

Glossary

Special isolation

Double and reinforced isolation between the first and secondary of the power supply or the transformer.

Electrocution

Passing of electric current through the human body.

Direct contact

Contact with an active part of the system, normally under voltage, such as, for example a conductor or a terminal.

Indirect contact

Contact with the conducting parts that are found accidentally and unforeseeably under voltage, as a result of an isolation problem, for example the enclosure of a washing machine.

Non undulated direct current

Direct current with limited sinusoidal ondulation and a maximum peak value determined by standard IEC HD 60364.

Typology: very low voltage...			
	FELV-functional (Functional Extra Low Voltage)	PELV-protective (Protective Extra Low Voltage)	SELV-safety (Safety Extra-Low Voltage)
Layout for alternating currents			
Description	Special insulation is not required. The loads are not isolated by grounding.	Presence of a special isolation. The loads are not isolated by grounding.	Presence of a special isolation. The loads are not isolated by grounding.
"Safety" note	■	■ ■	■ ■ ■ ■ ■

Application example with the SELV voltage

- Underwater lighting of a swimming pool
- Water jets, fountains
- Door bells
- Controls on the front of the panels
- Public lighting
- Pumps for liquids to maintain food fresh
- Supply of electronic components in DC, PLC
- In data centre, power supply in direct current with selectivity in case of breakdown.

Solutions for power supply in low safety voltage:

- SELV and PELV circuit in alternating current:
- The ABB modular transformers TM and TS are ideal for the power supply for discontinuous use loads, for example for bath pull cord.
 - To supply loads for continuous use, for example for the lighting system, both the ABB TS-C and the TM-S modular transformers are ideal.

FELV circuit in alternating current:

- In this case a transformer with a special isolation is not required; therefore the TM-C transformer with the voltages to secondary 12-24 V is ideal.

SELV, PELV or FELV circuit in alternating current:

- The ABB switching power supplies CP-D are ideal.
- If an elevated number of lines is connected downstream to a power source, a selective protection with EPD24 electronic devices is possible; a failure on a line is monitored thanks to the signalling contact, the line is disconnected and the operational continuity is preserved on the other lines.

All of these solutions accept the supply to the primary in 230 V AC

ABB solutions for the power supply of circuits in low voltage

Products for alternating current



Bell transformers TM and TS, for discontinuous use

Wide range of voltages (from 4 to 24 V) and powers (from 8 to 40 VA) and always in SELV voltage.

TS-C safety transformers and TM-S command and safety for continuous use

Modular from 25 to 63 VA or industrial from 50 to 2500 VA with 12/24 V output, a wide range for the SELV voltage! DIN rail mount up to 160 VA.

Products for direct current



Switching mode power supply CP-D

Optimal output accuracy with ±1% of voltage tolerance, six versions with different powers and voltages, always SELV. Say no to current ripple!

Selective protection of systems powered at 24 V DC EPD24

Isolation of the faulty lines for operational continuity and constant monitoring of the system, always in SELV voltage. Installation downstream from CP-D.

Benefits of the power supply in circuits at SELV safety extra low voltage:

- No protection is necessary either for the direct or the indirect contacts.
- Operational continuity even in cases of direct or indirect contact.
- The circuit, even if not kept under control, is always safe.

- Employment in several applications, from the residential (bathrooms) to industrial (data center, PLC)

Effect of the current on people

Effect of the passing of alternating current at 50 Hz through the human body:

Current	Effect
< 0,5 mA	No sensation
From 0,5 mA to 10 mA	Weak sensation
From 10 mA to 30 mA	Muscular contractions
From 30 mA to 75 mA	Breathing difficulties
From 75 mA to 1 A	Irreversible cardiac fibrillation, burning in areas where the current passes

Electrical resistance of the human body based on the voltage and the external conditions:

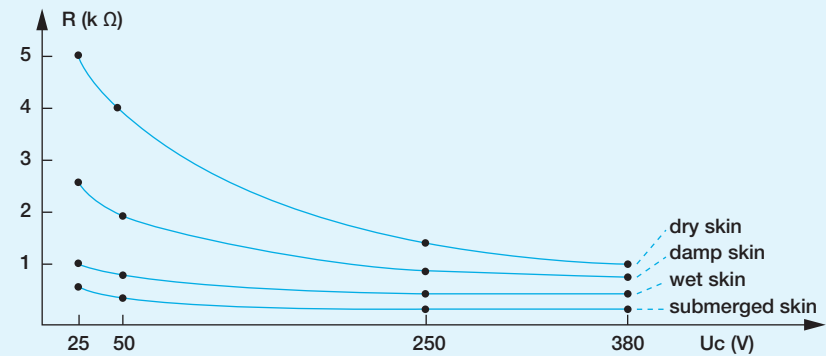
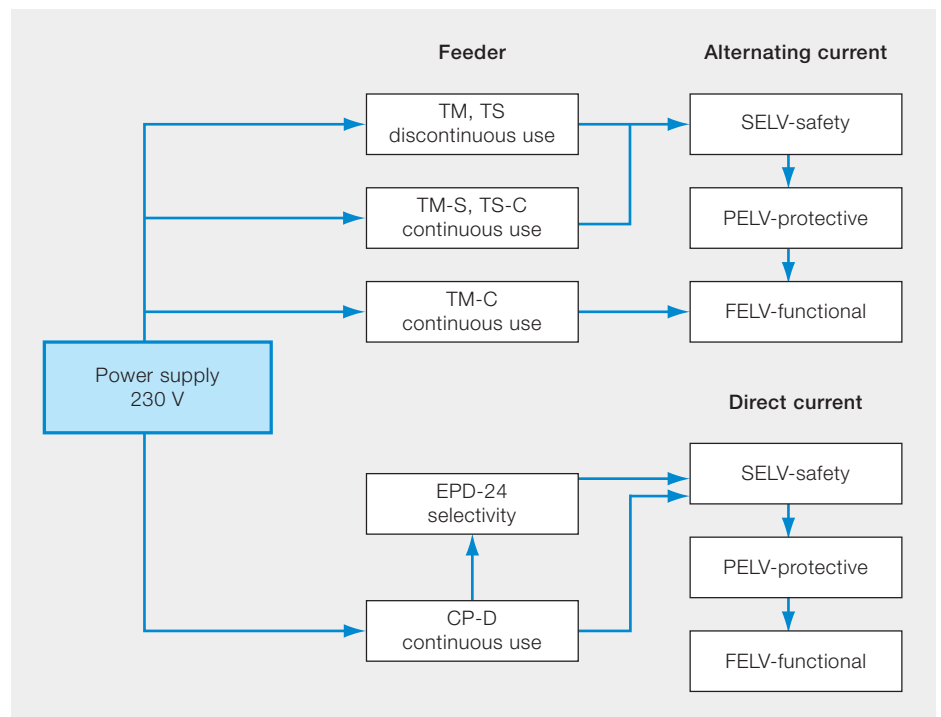

Diagram with the solutions to supply power to the low voltage circuit





S 200 MCB. In 1923 the first of its kind, today the best.



Back then and still today we are a trendsetting pioneer and technical leader for easy, safe and reliable use of electricity. Our circuit breakers S 200 and S 200 M are a living proof. So, with the new colored real contact position indication you can see the status within a twinkle of an eye. The optimized plane terminal plates guarantee right connection and can be reached even when the MCB is already installed. These and a lot more benefits make the miniature circuit breakers an effective addition to the successful System pro M compact®. Here you can find a wide range of compatible components for all your installation needs.

www.abb.com/lowvoltage

Power and productivity
for a better world™



Harmonics and neutral surge survey

Problems caused by the presence of harmonics can also be important. A good survey can consequently help the smooth running of the system

Francesca Sassi: Product Marketing Manager - DIN Rail Products
 Claudio Amadori: R&D - LP Division

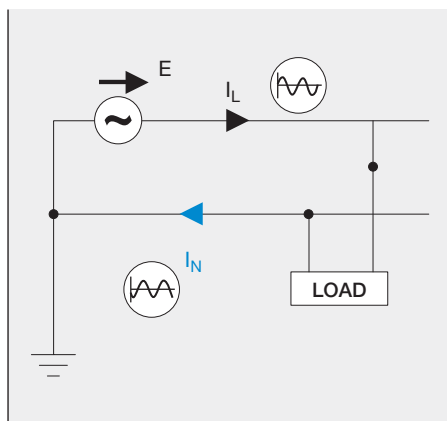

01

Nowadays, in any activity which uses significant amounts of energy, there is a need to control consumption, reduce costs and ensure operational continuity. However, it is decisive to know how the electrical system works in a detailed manner in order to be able to optimise consumption, charge flows, harmonics interference, voltage disturbance and other parameters which help to increase efficiency, to improve competitiveness and to reduce harmful emissions, an aspect which must not be neglected at present.

An efficient measurement and monitoring system of electrical quantities can be applied to all those situations which require:

- Containment of energy costs;
- The quality of the energy supplied;
- Operational continuity of systems.

An important aspect for the smooth running of a system is the level of harmonics and therefore harmonics analysis of voltage and current signals.

It is of fundamental importance to possess an instrument which is capable of surveying the harmonic components, in order to ensure the correct and efficient running of charges connected to the grid.

How do harmonics interfere in the smooth running of an electric energy distribution system?

Linear loads (without harmonics)

When electricity is generated by a power company, the shape of the voltage wave is sinusoidal.

Traditional types of loads, for example, are:

- Incandescent light bulbs and heaters (resistive loads);
- Motors and transformers (inductive loads);

If a system is connected to a sinusoidal voltage it absorbs sinusoidal current.

The current absorbed from a purely resistive or inductive load has the same progression and therefore the same shape of wave as the voltage which supplies it.

However, in linear loads the shape of the wave is the same as the shape of the voltage wave (they are both sinusoidal) and are not affected by harmonics.

In a single-phase circuit, the current in the neutral conductor is always the same as the phase conductor (except in the case of earthed dispersion, in this case it is smaller), independently from the type of load, even a non-linear one (figure 1).

Therefore the neutral conductor section has to be the same as the phase conductor and it is never necessary to protect the neutral wire from a surge.

In a three-phase circuit with a neutral wire, the neutral current is the vectorial sum of phase currents, which themselves

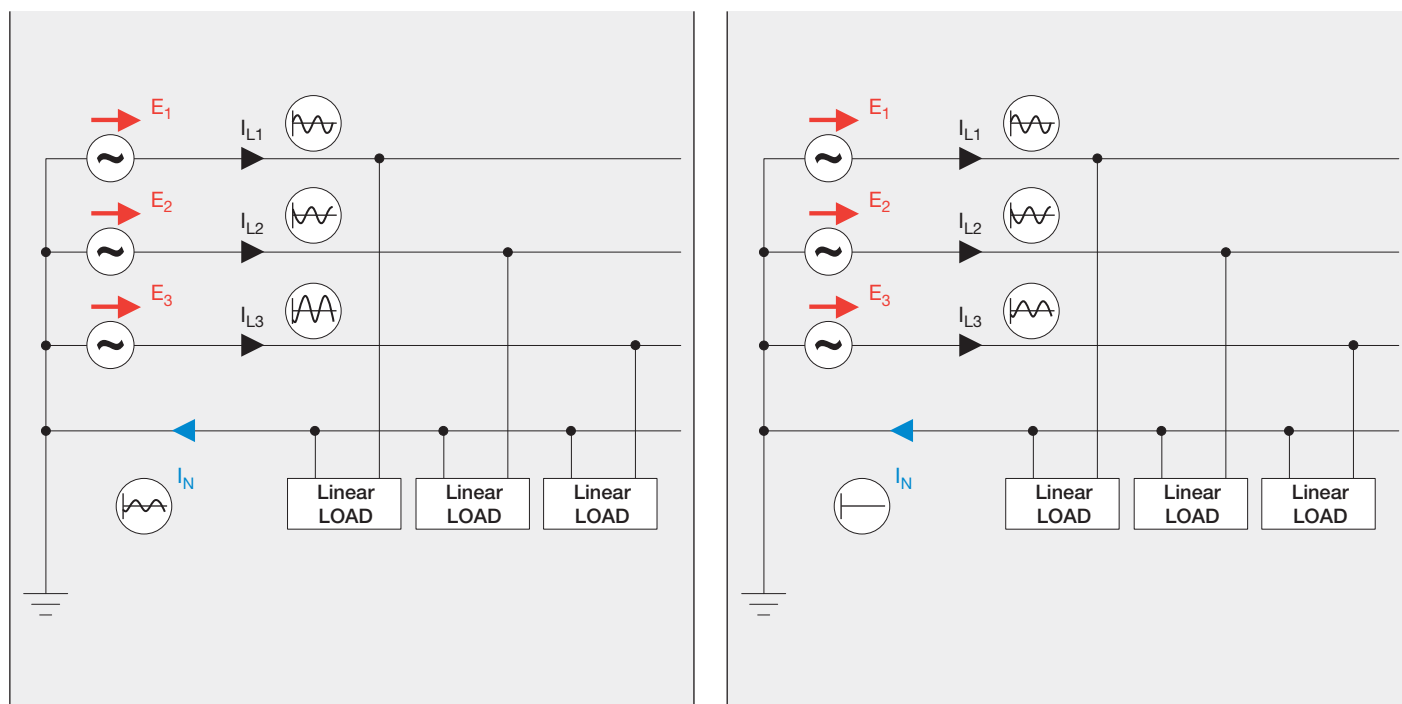

02

03

are out of phase by 120° (if the loads have the same power factor on three phases).

If the loads are linear, they are all the more equally distributed over three phases and the neutral current will be smaller (figure 2).

If the loads are perfectly balanced on three phases, the neutral current is null (figure 3).

On the contrary, the maximum neutral current is achieved, for example, when a phase is empty.

In any case, if the loads are linear, the neutral current is never greater than that of the phase, it is equal at most (the only exception could manifest itself with charges over three linear phases, but with power factors that are very different, this is however an unrealistic situation).

Non-linear loads

The technology and the necessity to reduce consumption, as is increasingly requested by the market, has developed new high-yield charges which can function with a lesser degree of energy absorption.

In recent decades, the effect of harmonics was generally only felt by electric energy providers and heavy industry, such as foundries and metal works. However, from the 1980s onwards, loads capable of introducing harmonics became notably more widespread even at a household level or in the service industry

Non-linear loads also distort the sinusoidal wave of the phase current in a notable fashion. In fact, absorbed current in non-linear loads has a distorted shape, which diverges from the applied voltage wave, being a non-sinusoidal periodic alternate, but with width and frequency, inside the period and equivalent to the sinusoid.

Examples of non-linear loads are:

- Computers, printers, monitors;
- UPS;
- AC/DC and DC/DC static converters;
- Induction ovens;
- Electronic controllers;
- Supply switches (even in household appliances);
- SCR/Triac controlled lighting systems;
- Adjustable-speed drive gears;
- X-ray machines;
- MRI machines.

According to Fourier's theory, the distortion of the sinusoidal shape is described as the generation of current harmonics in an uneven sequence (150 Hz, 250 Hz, 350 Hz, etc.) which are injected by the load on the supply grid.

The harmonics in an even sequence and the continuous offset (harmonics zero) are usually absent or negligible.

Usually, the content of single harmonics is expressed as a percentage of the fundamental harmonic (grid frequency harmonic, 50 Hz, level 1 harmonic).

01 Single-phase circuit with a linear load

02 Three-phase circuit with linear loads

03 Three-phase circuit with linear loads, perfectly balanced on three phases

The total current, as an effective value can be expressed as a quadratic sum of the single harmonics:

$$I = \sqrt{I_1^2 + (I_1 \cdot I_3 \%)^2 + (I_1 \cdot I_5 \%)^2 + (I_1 \cdot I_7 \%)^2 + \dots}$$

$$= I_1 \sqrt{1 + (I_3 \%)^2 + (I_5 \%)^2 + (I_7 \%)^2 + \dots}$$

The total quantity of harmonics is expressed with the total harmonic distortion (THD), which is an indication of how distorted the initial sinusoid is:

$$THD\% = \sqrt{(I_3 \%)^2 + (I_5 \%)^2 + (I_7 \%)^2 + \dots}$$

THD (Total Harmonics Distortion) corresponds to the total harmonic distortion of the fundamental wave, which considers the contribution of all the harmonic components and is a valid indicator of the presence of harmonics. The THD value is expressed as a percentage.

The IEC EN 50160 Standard in relation to “Voltage characteristics of electricity supplied by public distribution networks”, Article 4.11, “Harmonic voltage”, prescribes that supply voltage (including all the harmonics up to 40) must be smaller or equal to 8%.

The THD indication for the presence of harmonics in the current, even a percentage of several units, becomes an important indicator for the need for detailed harmonics analysis, with the aim of detecting harmonics, such as the third, which can be possible causes of system malfunction.

Figures 4a and 4b illustrate in terms of percentages, the harmonics which are generally generated by two types of charges that are extremely widespread in offices and in households: supply switching (found in computers, for example) and compact fluorescent lighting.



ANR front panel network analyser, ideal for monitoring voltage and current signals and the relative effects of harmonics due to the measurement of the THD rate.

04 Percentages of harmonics generated by supply switching (4a) and fluorescent lighting (4b)

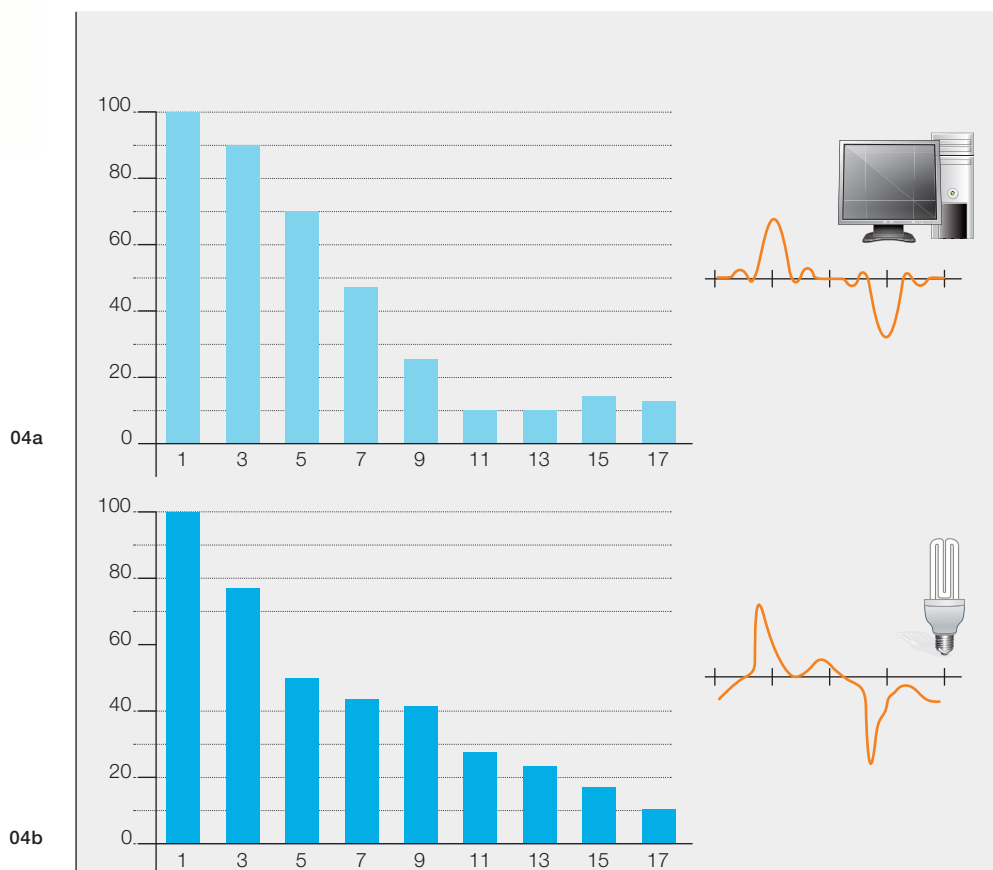

One of the most important consequences of the presence of non-linear loads is the increase of current in the current of the neutral conductor in three-phase systems, even when the loads are perfectly divided amongst the three phases (figure 5). In fact, for non-sinusoidal wave shapes the rules of the vectorial sum of sinusoids fail, causing the reciprocal cancellation of currents on the neutral conductor.

At the frequency of 50 Hz, the dominant harmonics generated from non-linear loads are of the odd sequence.

- The third harmonic (150 Hz);
- The fifth harmonic (250 Hz);
- The seventh harmonic (350 Hz);
- etc.

When the harmonics generated by non-linear loads reach a sufficient amplitude, a phenomenon of interaction takes place with the internal distribution system and with other equipment installed on the same system. They interact particularly with the impedance of the distribution system, creating voltage distortions and loss of energy.

Therefore it is possible to check different problems in relation to the equipment, including:

- Unwanted activation of residual current relays;
- Current increase in phase conductors;
- Notable current increase in the neutral conductor, with subsequent overheating;
- Overheating of transformers and increase in noise level;
- Increase in speed of disc in the induction energy meters;
- Premature ageing of electrical components;
- Malfunction of power-factor capacitors;
- Malfunction of filter condensers and weak stand-by power of UPS;
- Reduction of power factor and the application of penalty clauses by the energy distributor.

When the loads are balanced, even the harmonic currents, like the phase currents to the fundamental frequency (50 Hz), they tend to cancel themselves out.

This principle is valid for all harmonics, with the exception of the odd ones in multiples of three which, contrary to the others, make a sum of their own and return exclusively through the neutral conductor, causing a surge if not adequately sized.

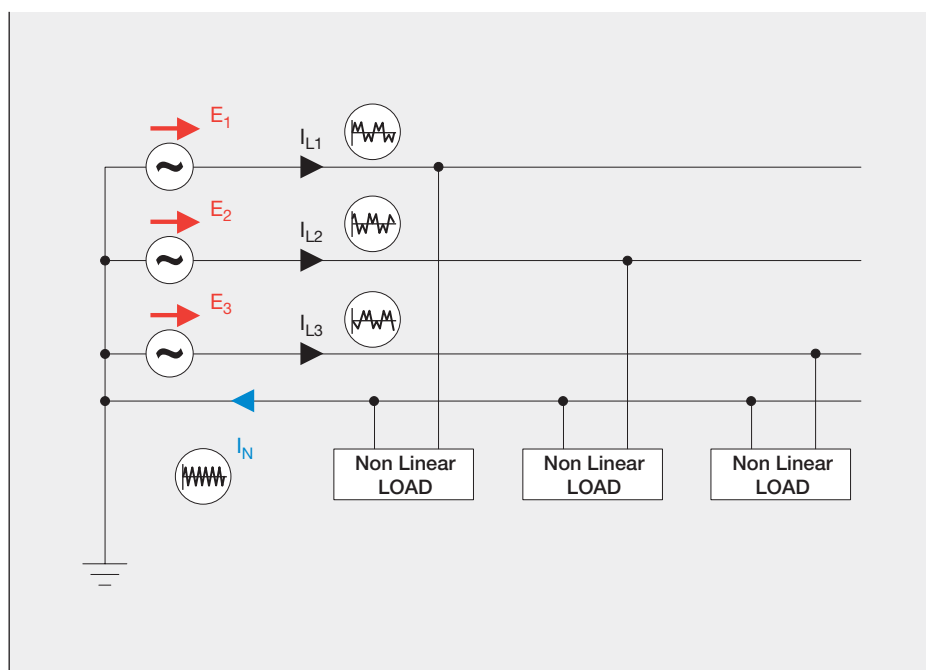

05 Three-phase circuit with non-linear loads

Bibliography

- IEC 60364: "Low voltage electrical installations".
- CEI 64-8: "User electrical systems with a rated voltage of no more than 1000 V in alternating current and 1500 V in direct current"
- ABB: "Power factor correction and harmonics filtering in electrical systems". Technical guide, no. 8
- ABB: "Guide to Harmonics with AC Drives". Technical Guide, no. 6.
- Gianfranco Ceresini: "Guide to harmonics issues in industrial plants" Voltimum.
- Angelo Baggini, Jan Desmet: "Harmonics – Neutral Sizing in Harmonics Rich Installations". Power Quality Application Guide. Leonardo Power Quality Initiative.

In electrical system supplied by three-phase systems, the non-linear star loads which generate harmonics in multiples of three can cause surges and, subsequently causes overheating in the neutral conductors.

A surge in the neutral, could cause deterioration due to overheating of the insulation on the conductor, with the consequent dangers, it also causes an excessive drop in voltage and the subsequent movement to neutral, with the possibility of surges between a phase and neutral. Furthermore, it can cause harmonic distortion on the voltage, which can affect the operation of linear devices.

It is clear that it is very difficult to calculate the exact effects of harmonics, especially in the case of unbalanced charges. In many cases one has to proceed in an empirical manner implementing measures on the system already in use.

In general terms, the maximum current in neutral must never exceed the effective value of the sum of the single-phases, thus triple the phase current if the loads are balanced. Moreover, it is costly and fundamentally useless to triple the section of the neutral conductor.

Usually, over-sizing of a factor never exceeds 1.5 or 1.7, but in most cases it is preferable to maintain the neutral at the same level as the phase.

The IEC Standard for systems (IEC 60364, 2008), in Article 431.2.3 constantly stipulates the protection of the neutral conductor, in the event that, due to harmonics, the overflow of its range is expected. It is a peremptory stipulation and it validates independently from the neutral section (that is to say when $S_N \geq S_P$).

It is clear that the protection of the neutral is not in itself a suitable solution to the problem of surges due to harmonics, since it resolves the surge problem by interrupting supply.

It is first of all necessary to provide for the measuring of a neutral conductor suitable to the harmonics present in the system in normal conditions.

Moreover, in many practical cases it can be difficult or even impossible to sufficiently assess with any precision the neutral current in different operational scenarios, especially when the characteristics of the devices that will be supplied by the plug, are not known.

If the loads are single-phase, an efficient but costly solution is to keep the lines which supply the single-phase load separate (that is to say, to avoid the common neutral) until the supply is delivered.

Besides, such a measurement can seem excessive and, in fact useless, ensures "in every case" that the neutral current (double or triple the phase) does not exceed its range. In many cases it is necessary to use the cables already in use in the system.

In situations like these it is necessary to provide for surge protection in neutral.

Thus, it appears that monitoring the level of harmonics by means of grid analysers, to be a financially sound solution, which allows for the prevention of surges in the neutral conductor, ensuring continuous service.

Electric power and modernity: new scenarios, new possibilities

They have been waiting 110 years to change the light-bulb

The oldest functioning light bulb can be found in Livermore, California, ironically in one of the sunniest places of the United States. It was turned on in distant 1901, it is located in the local fire station, at a height of about five metres, supported by a long and dusty wire.

Its secret possibly, is that it has never been switched off in all this time, if only for a few hours during a move in 1936, thus avoiding mechanical stress from usage.

It was made by the Shelby Electric & Co.

in Ohio, it has been constantly switched on and has worked ever since thanks to the excellent quality of its external isolation. In 2001, its centenary year, a big party with all the local dignitaries was celebrated in its honour. The record of this light bulb could, however, be undermined by an Italian (at the time) light bulb, found in the town of Fiume (modern day Slovenia), which dates back to 1895 and is used inside a cinema. The finding is, however, awaiting official confirmation.



The music is about to begin. Turn off the neighbourhood

Jean-Michel Jarre is one of the pioneers of electronic music, he has an incredible number of concerts to his credit, which are often characterised by elements such as lights, fireworks and lasers.

The numbers at his concerts are impressive, so much so that he got into the Guinness Book of Records for a concert held in Moscow in front 3.5 million people.

One of the most particular concerts could be the spectacle held in China, in Beijing in 1981, which was also the first time a Westerner played there. It is particular because the concert required a quantity of energy which was greater than that available. The Chinese technicians did not give up, they chose a drastic but efficient solution: an entire neighbourhood went without electricity for the duration of the show!



Fish can give you an electric shock!

Electric fish, or more precisely electrophorae, are widespread in the rivers and lakes of South America and Africa, except for cramp-fish, which live in salt water. They are not to be confused with deep-water fish, which have light-producing organs by means of luminescence, these fish have the capacity to produce an electric field thanks to a particular organ, called an electric organ. This is due to special muscular cells covered by nerves, it can produce electric fields by contracting these at the right time. These fish are divided into two categories, according to the intensity of the electric field produced.

Strong electrophorae are capable of producing high voltages in the hundreds and currents which are measured in Amperes, values which can be dangerous for humans, they use the electric field to hunt usually, by stunning or killing their victim.

Weak electrophorae, on the other hand, have a very low electric field, which is mostly used for direction finding (electro-localisation) and communication (electro-communication) with other members of its species.

We are not the only ones to have understood how to use electricity!



Energy efficiency in buildings

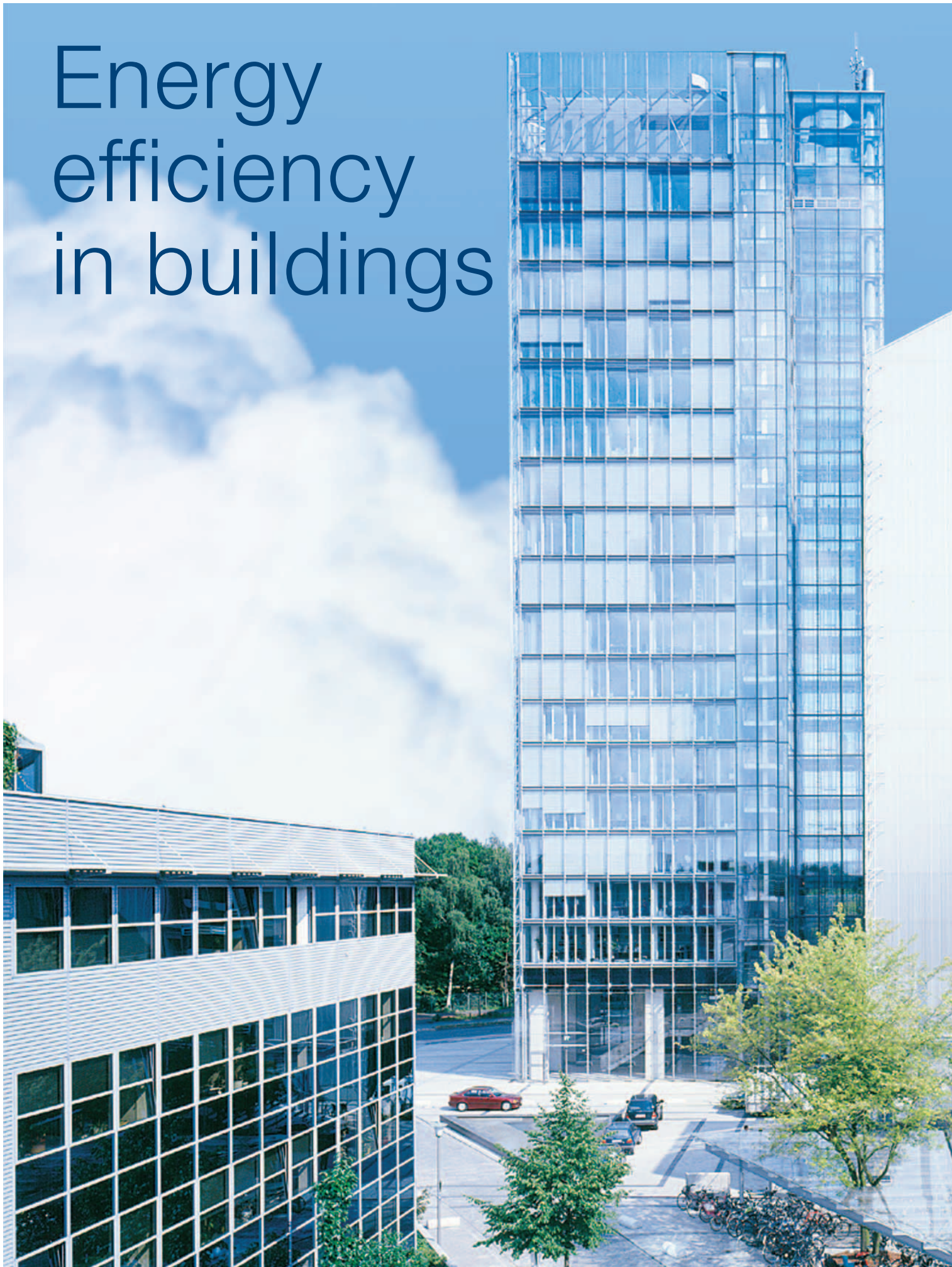



European Standard EN 15232 defines energy classes of automation systems and technical building management, assessing buildings which, thanks to solutions designed to reduce consumption, ensure high energy performance.

John Beniston: Head of International Sales KNX

It is by now recognised that modern building automation systems, both for residential buildings thanks to home and building automation and for general purpose properties thanks to building automation applied to multiple technologies for non-residential buildings, make a significant contribution to energy efficiency, reducing consumption, carbon monoxide emissions, as well as ensuring high comfort and safety levels.

Around the world new legislation is promoting the use of energy efficient technologies. The European Standard EN 15232 “Energy performance of buildings – Impact of Building Automation, Controls and Building Management”) was compiled in conjunction with the Europe-wide implementation of the directive for

energy efficiency in buildings (Energy Performance of Buildings Directive EPBD) 2002/91/EC. The standard describes methods for evaluating the influence of building automation and technical building management on the energy consumption of buildings.

Four efficiency classes A to D have been introduced to this purpose, for BAC (Building Automation and Control) systems; these classes are assigned solely to buildings equipped with automation and control systems. The potential savings for thermal and electrical energy can be calculated for each class based on the building type and building purpose, as shown in table 1 of Standard EN 15232. The values of the energy class C are used as the reference for comparing the efficiency.

Building Automation and Control (BAC) efficiency classes according to EN 15232	Efficiency factor for thermal energy			Efficiency factor for electric energy		
	Office	School	Hotel	Office	School	Hotel
A High energy performance building automation and control system (BACS) and technical building management (TBM)	0.70	0.80	0.68	0.87	0.86	0.90
B Advanced BACS and TBM	0.80	0.88	0.85	0.93	0.93	0.95
C Standard BACS	1	1	1	1	1	1
D Non energy efficient BACS	1.51	1.20	1.31	1.10	1.07	1.07

Function list and assignment to energy performance classes (section from table 1 of the EN 15232:2007 [D])

Heating / cooling control	Ventilation / air conditioning control	Lighting	Sun protection
A <ul style="list-style-type: none"> – Integrated control of each room with request management (by usage, air quality, etc.) – Indoor temperature control of distribution network water temperature – Total interlock between heating and cooling control 	<ul style="list-style-type: none"> – Demand or presence dependent air flow control at room level – Variable set point with load dependant compensation of supply temperature control – Room or exhaust or supply air humidity control 	<ul style="list-style-type: none"> – Automatic daylight control – Automatic occupancy detection manual on / auto off – Automatic occupancy detection manual on / dimmed – Automatic occupancy detection auto on / auto off – Automatic occupancy detection auto on / dimmed 	<ul style="list-style-type: none"> – Combined light/ blind/HVAC control
B <ul style="list-style-type: none"> – Individual room control with communication between controllers and BACS – Indoor temperature control of distribution network water temperature – Partial interlock between heating and cooling control (dependent on HVAC system) 	<ul style="list-style-type: none"> – Time dependent air flow control at room level – Variable set point with outdoor temperature compensation of supply temperature control – Room or exhaust or supply air humidity control 	<ul style="list-style-type: none"> – Manual control of daytime lighting – Automatic occupancy detection manual on / auto off – Automatic occupancy detection manual on / dimmed – Automatic occupancy detection auto on / auto off – Automatic occupancy detection auto on / dimmed 	<ul style="list-style-type: none"> – Motorized operation with manual blind control
C <ul style="list-style-type: none"> – Individual room automatic control by thermostatic valves or electronic controller – Outside temperature compensated control of distribution network water temperature – Partial interlock between heating and cooling control (dependent on HVAC system) 	<ul style="list-style-type: none"> – Time dependent air flow control at room level – Constant set point of supply temperature control – Supply air humidity limitation 	<ul style="list-style-type: none"> – Manual control of daytime lighting – Manual on/off switch + additional sweeping extinction signal – Manual on/off switch 	<ul style="list-style-type: none"> – Motorized operation with manual blind control
D <ul style="list-style-type: none"> – No automatic control – No control of distribution network water temperature – No interlock between heating and cooling control 	<ul style="list-style-type: none"> – No air flow control at room level – No supply temperature control – No air humidity control 	<ul style="list-style-type: none"> – Manual control of daytime lighting – Manual on/off switch + additional sweeping extinction signal – Manual on/off switch 	<ul style="list-style-type: none"> – Manual operation for blinds

The aspects to be taken into consideration to obtain most benefits from building automation are, obviously, those connected to lighting and air conditioning. Getting into more detail, the possibilities of intervention are quite diverse and can be connected for example, to use in single areas (control in the room being used), the automatic turning off/adjustment of devices according to a timed program or according to environmental parameters (lighting, temperature, etc.), overload prevention, automatic control of safety devices for solar radiation and the opening/closing of fixtures, as well as for many other operative situations.

The actual possibilities for the optimisation of building energy performance thus depend on different factors, including construction characteristics and intended use, the geographic location where they are situated and exposure to climatic factors, for example from solar irradiation, for these reasons quantification of possible energy savings must be seen in each case for all buildings being considered.

The adjacent table shows the differences in energy consumption for three building types in the energy efficiency classes A, B and D relative to the basis values in rating C. For example, by using class A, 30 % of the thermal energy can be saved in offices.

ABB i-bus® KNX



ABB i-bus® KNX is a complete system for Building Automation composed of modular systems for DIN rail, capable of controlling and monitoring any technological plant in a building according to KNX International Standard, optimising and rationalising electric electricity consumption:

- Lighting control and adjustment;
- Air conditioning (heating, conditioning and ventilation systems);

- Control of shutters, blinds and motorised devices;
- Safety;
- Energy management and monitoring of electricity consumption;
- Supervision (centralised management of systems);
- Remote control of building.



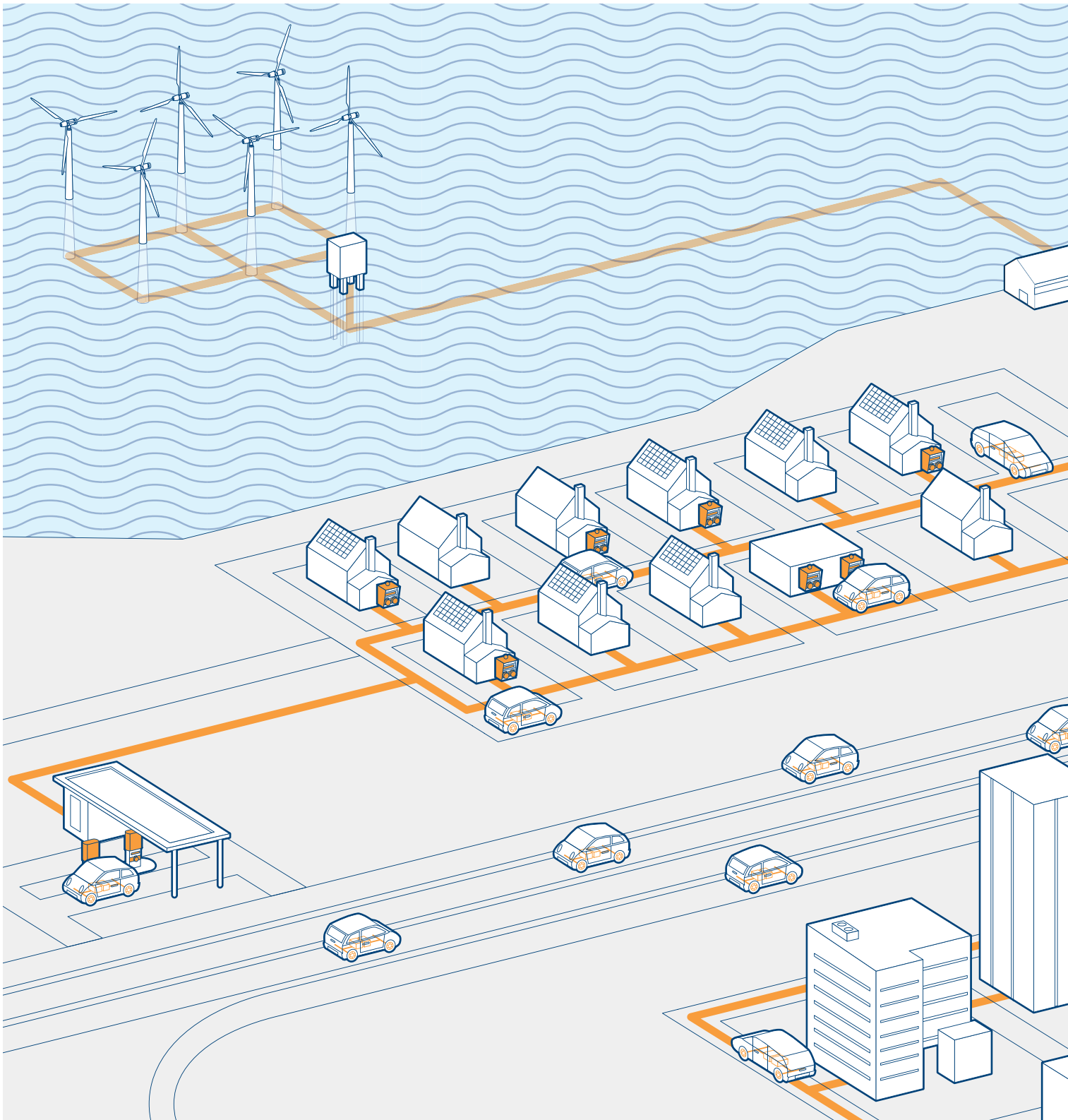

The new era in electric mobility

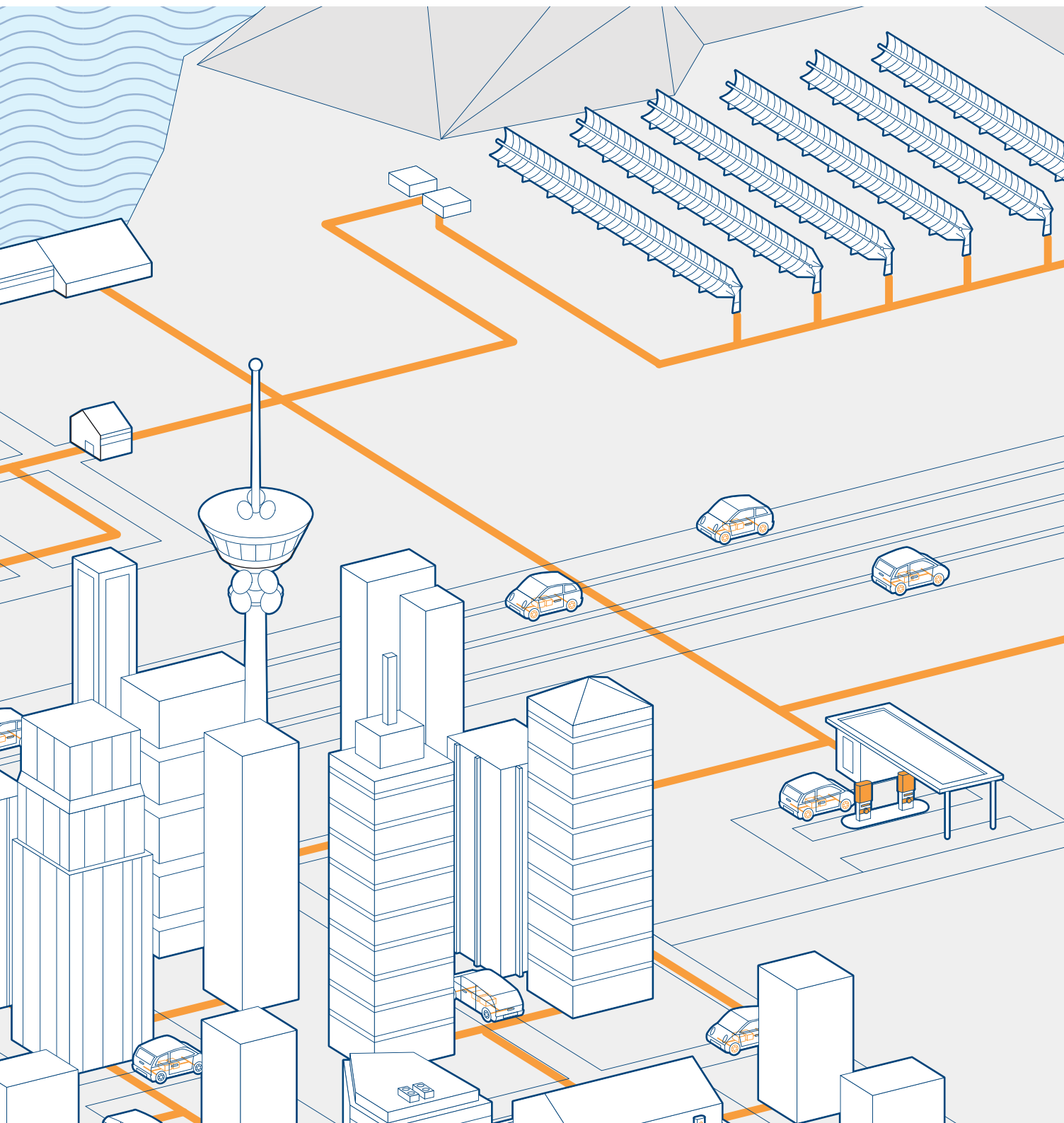

Electric vehicles, that is to say those vehicles which move thanks to electric motors supplied by rechargeable on-board batteries, are in no way a novelty. History shows us that the first electric carriages appeared between 1832-35, just after the discovery of the principles of electric motors and before the invention of the internal combustion engine. In fact, during the first decades of the history of cars, the speeds

and distances covered by drivers were so modest that the electric car was much admired and competed with petrol and steam driven cars which appeared during the second half of the 19th Century. Indeed, the electric car, even then had many advantages: it was easy to drive (there were no gears or clutch), it was silent, there were no vibrations, it did not emit fumes, it required minimal upkeep and start-up was immediate.



Electric vehicles were most popular around the turn of the 20th Century. Proof of their popularity in the United States at the time can be found in the world of cartoons. The model which inspired Walt Disney to draw Elvira “Grandma Duck” Coot’s car was an electric vehicle: a 1912 Ohio Electric Model “M” (with a top speed of 30 km per hour and a range of 50 km).

Subsequently, improvements in internal combustion engines, the development of the road network and the consequent increase in performance requirements for cars, all helped petrol engine to prevail. Unlike their steam powered rivals, electric cars however, never completely disappeared from the market. Besides the micro-cars used for example on golf courses, train stations and in airports, some specialised firms have, for years produced a certain number of electric cars and vans, which derive from the corresponding models with thermal motors.

Lately, an important technological development has made the electric vehicle fashionable again. Lithium batteries (lithium ion and lithium ion polymer batteries) which have replaced acid/lead batteries (the traditional batteries used in petrol cars) and nickel/cadmium batteries (these accumulators continue to be used on scooters and micro-cars due to the lower cost). Lithium batteries not only have a higher charge density (from 110 to 200 Wh/kg compared to 30-50 Wh/kg for lead batteries and 48-80 Wh/kg for nickel/cadmium batteries), but they suffer nonetheless from the so-called “memory effect”, in other words the battery can be recharged only when completely discharged.

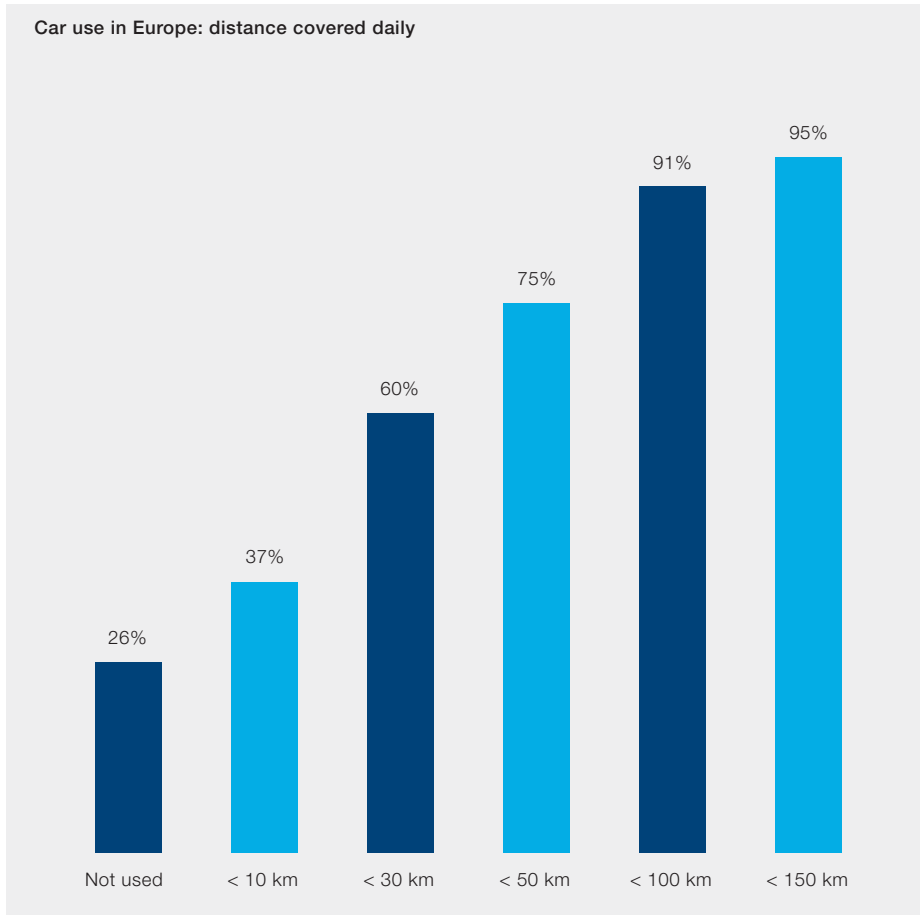

02

01

Benefits and limitations of electric vehicles

The development of batteries has largely broaden the limitations of electric cars, making a certain level of distribution a concrete possibility. Studies on the potential development of the electric car market, do not always give the same results. According to ACEA (Association des Constructeurs Européens d’Automobiles) between 3% and 10% of new cars will be electric from 2020. In any case, there is a very high potential.

Both car manufacturers and political administrations see the development of electric cars as an interesting opportunity for the following reasons:

- Low rate of environmental pollution, especially for the elimination of local emissions (particulates, NO_x, CO, etc.), but also for the global reduction of CO₂ (global emission reduced, but not eliminated since CO₂ emissions during the production of electric energy have to be considered);
- Low running cost (unfortunately not low enough to recover the outlay of the initial purchase)¹⁾;
- Silence, lack of vibrations, notable acceleration, a pleasure to drive.

Electric runabouts which are appearing on different car manufacturers catalogues, are in effect, real cars, which equal their gas or petrol rivals in terms of comfort, performance and safety. The pioneering times of the electric 1990 Fiat Panda Elettra (the batteries took up the back seats), have come and gone.

However the range limitation remains: 100 – 150 km with a fully charged battery for runabouts, up to 150 – 200 km for medium-sized vehicles. These are much shorter ranges than in combustion powered vehicles. Furthermore, range is very much influenced by the use of electric devices such as lights, windscreen wipers and heating. Range is followed by another big limitation for electric cars: a full recharge, using domestic power of not more than 3kW takes up to 8 hours.

A further development in batteries is not expected before 2020, when innovative batteries such as lithium/air batteries with a higher charge density (circa 1000 Wh/kg) will provide electric cars with the same range of conventional vehicles.

It is understood that the electric vehicles already on the market, like the ones which will be available in the coming decade will not be able to completely replace fuel-

01 Source CEI-CIVES
 02 Ohio Electric Model "M" from 1912 (from Quattroruote)

¹⁾ Currently, an electric vehicle costs between 50-100% more than a similar-sized combustion powered vehicle. The high cost of electric vehicles is largely due to battery costs, which are around 300 – 600 €/kWh.

driven cars. However, considering the average daily distance covered by many runabouts is no more than 50 km, the daily charge which is carried out during the night, in the garage or garden, is sufficient for many drivers needs. The night time charge is also advantageous due to the lower rates for electric energy at this time, at night the rates decrease with the energy demands and consequently also lowers the price on the bill (it can be useful, for this purpose, to charge the car using a timer switch).

Obviously, it is necessary that the commercial development of electric vehicles, in order that they are accepted by the market, even as niche products, is coupled with suitable incentives to compensate the purchase price, which is still very high, and the limitations of use. Not only financial incentives should be offered (such as cash incentives or discounted electricity rates): it could be useful to launch innovative purchasing or rental packages (such as the payment by instalments for vehicles and energy supply or the battery rental) and other incentives which could be entry into traffic restricted areas or reserved car parks equipped with charge points etc.

Electric cars and use of renewable sources

Another aspect which is worth mentioning is the existing relationship between electric vehicles and the use of energy generated from renewable sources. As has been noted, many of these renewable sources are intermittent and cannot be regulated by the national grid provider (wind energy for example). They are consequently difficult to implement in terms of network management, in comparison to traditional sources (coal, methane, uranium, etc.) which can be regulated on the basis of demand from the network or which, at least, are constant. In fact, electric cars are seen as loads made up of batteries which, by their very nature, are capable of being supplied even in an intermittent fashion. Fundamentally, the idea is to use the supply at times when it is more plentiful and cheaper, that is to say during production peaks of intermittent sources and/or during periods of low energy demand on the network. Obviously, it is necessary that the stations earmarked for charging electric vehicles are controlled by a centralised system, in terms of a smart grid, keeping in mind the conditions for supply stipulated in the contract. Moreover, it would be unimaginable to manage multiple charges of tens of kilowatts in a stochastic fashion, without higher centralised control.

But, there is more. Given that for most of the time, the vehicles are stationary, in a few years it will be possible to use the vehicle connected to the grid as an electricity reserve to be ceded to the grid in the case of necessity (V2G: vehicle to grid energy flow). The driver can use his/her car as sort of UPS in the case of a black out, in case more power is needed or if energy rates are high. In an even more futuristic scenario, even the grid provider could be authorised to collect energy from vehicles connected to grid to cover peaks in demand. Electric vehicles, if they became common enough, could become one of those accumulation services necessary for the future smart grids to de-couple the moment of the availability of intermittent renewable sources from their use. It would be a completely free accumulating system, considering that these batteries would already be present in the grid for the operation of electric vehicles.

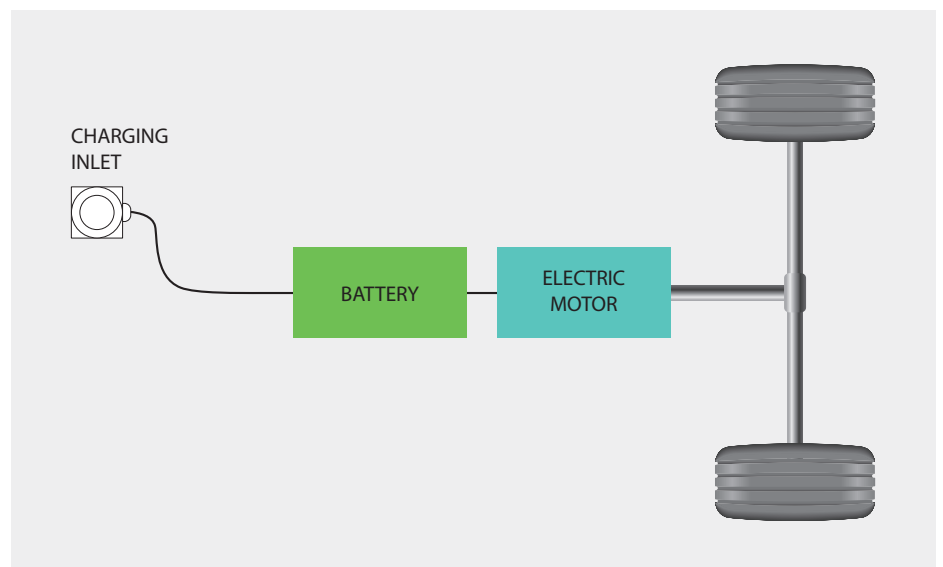

03 Schematic diagram of a PEV

Characteristics of electric vehicles

Electric vehicles which run solely on electricity, by means of a plug can be recognised by the PEV abbreviation (Plug-in Electric Vehicles)⁽²⁾. In order to surpass range limits, another category of electric vehicles has been introduced: they are the so-called “hybrid plug-ins” (PHEV Plug-in Hybrid Electric Vehicles). They are basically vehicles which are capable of operating with both electric energy and with combustible fuel (diesel for example). PHEVs are divided into “series” PHEV and “parallel” PHEV. In “series” PHEVs⁽³⁾, only the electric motor supplies the torque to the wheels and the combustion motor only works as a generator for charging the batteries.

In “parallel” PHEVs both motors power the wheels and one or the other or both can be used depending on the design criteria used by the manufacturer.

Battery range in PHEVs is usually limited to tens of kilometres, with savings in terms of cost and space on the car. It is however, a range which is capable of covering a large part of the average daily distance of many cars and which allows one to take advantage of the financial and environmental advantages of electric traction. In the case of bigger distances or of greater performance requests, the combustible motor takes over: even in this case it is possible to benefit, by taking advantage of the higher efficiency of hybrid

vehicles (for example, the recovery of energy during breaking). It is expected that PHEVs will be very common in the years to come. They probably represent the best compromise at present, coupling financial and environmental advantages which derive from the adoption of electric energy technology and the performance and range which can be obtained from combustion powered vehicles.

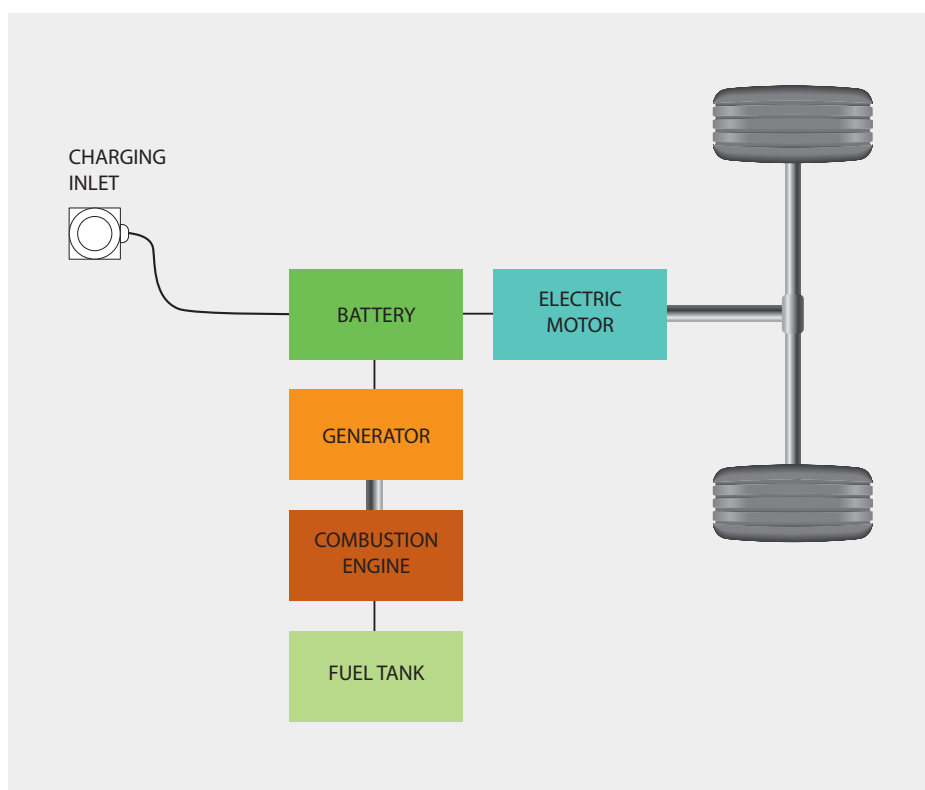

04

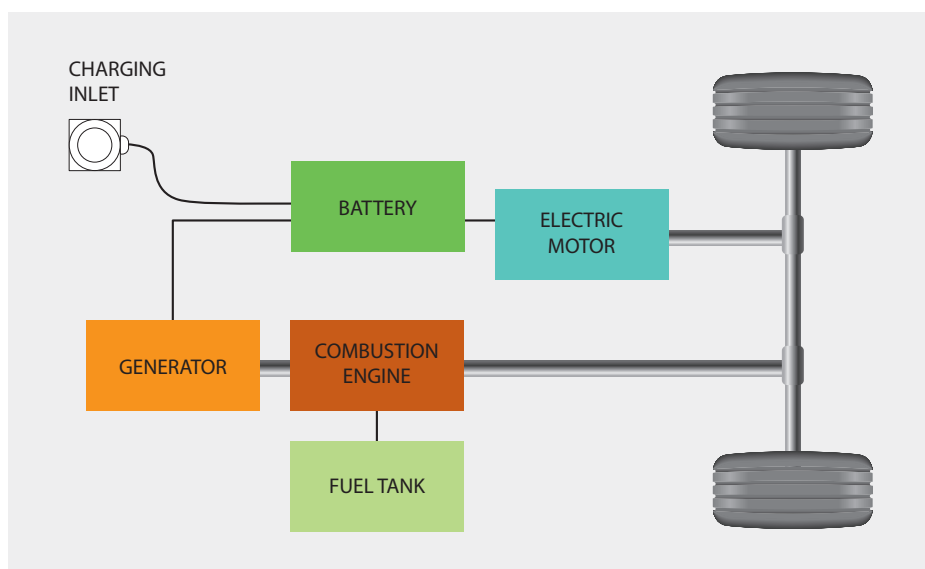

05

²⁾ BEV (battery electrical vehicles) and ZEV (zero-emission electrical vehicles) are synonymous with the term PEV
³⁾ Series PHEVs are also known as EREVs (Extended Range Electric Vehicle).

04 Schematic diagram of a series PHEV
 05 Schematic diagram of a parallel PHEV

Table 1 lists some of the characteristics found in PEV/PHEV currently on the market.

They are indicative values, for the actual data you must consult, for each model, the documentation issued by the manufacturer.

Charging speed

As we have already mentioned, a fundamental aspect in relation to electric vehicles (PEV or PHEV) is the charging speed, which is linked to electric power at the charge point. We can classify, as shown in table 2, the charging power in the following macro-categories, which correspond to the charging speeds indicated (they are only rough values, which correspond to an average consumption of 150 Wh/km and a battery capacity of 30 kWh)⁴⁾.

It can be understood how the “charging power” of a combustion-driven vehicle is higher than that of an electric one: in the first case a few minute to fill up the tank ensure a range of hundreds of kilometres, this corresponds to a charge power of several hundred kilowatts (in fact the energy density of petrol is 13 kW/kg).

In order to meet the requirements and peculiarities of “refuelling” electric cars, further to night-time charge points, “biberonnage” stations will be developed and located in public areas such as car parks, cinemas and shopping centres. By “biberonnage” (from the French meaning “bottle feeding”), we mean the even partial charging of batteries during normal stationary periods, which can be used to advantage since more power is available for the charge: in the semi-fast mode, for example, half an hour of charging (about the time of a supermarket visit) ensures that the vehicle has several kilometres more range.

Charging modes

Another important aspect, which is worth considering, regards the classification of the different methods of charging according to current standard (IEC 61851 series Standards). It is better to get confidence with this terminology which will become common place.

Mode 1 charging

Is the method which uses a common 230 V/16 A one phase socket outlet (a 400 V/16 A three-phase socket could also be used). The socket can be of the household type⁵⁾ (“Schuko” for example) or an industrial one (IEC 60309-2). Specific safety systems are not provided for, nor is communication between the vehicle and the permanent structure (it is necessary that the socket outlet is protected by a residual current circuit breaker, at least of type A, having a rated residual current of 30mA). Mode 1 charging is used for slow charging, mostly for scooters and micro-cars. In some countries mode 1 charging is not permitted or is subject to limitations⁶⁾. In the United States, for example, mode 1 charging is outlawed, whilst in Italy it authorised only on private property.

⁴⁾ The “classification” displayed in the table is in accordance with a widespread but unofficial terminology. In the USA the following SAE-defined terminology is in use:
 AC level 1: 120 V / 16 A up to 1,9 kW DC level 1: 200-450 V, 80 A up to 36 kW
 AC level 2: 240 V / 80 A up to 19,2 kW DC level 2: 200-450 V, 200 A up to 90 kW
 AC level 3: over 20 kW DC level 3: 200-600 V, 400 A up to 240 kW

⁵⁾ In reality common household sockets are not suitable for continuous use at their nominal current (16 A). Consequently, when using household sockets, it is necessary to limit the effective current to a lower value (e.g 10 A).

Category of vehicle	Typical battery capacity	Average consumption in electric mode	Average range in electric mode
PEV scooter	3 kWh	60 Wh/km	50 km
PEV mini	10 kWh	100 Wh/km	100 km
PEV compact	20 kWh	150 Wh/km	130 km
PEV medium	30 kWh	180 Wh/km	170 km
PHEV	5–20 kWh	250 Wh/km	20-80 km

Recharging speed	kW	Typical mains connection	Range corresponding to 10 minute recharge	Complete recharge time	Charging mode
slow	up to 3.7 kW	AC 230 V / 10-16 A	circa 3 km	circa 8 hours	1, 2 or 3
accelerated (“medium” or “semi-fast”)	3.7-22 kW	AC 400 V / 16-32 A AC 230 V / 16-70 A	up to 15 km	from 1 to 8 hours	3
fast	22-43 kW	AC 400 V / 32-63 A DC adjusted by vehicle	up to 30 km	from 30 minutes to 1 hour	3 or 4
ultra fast	over 43 kW	DC adjusted by vehicle	over 30 km	from a few minutes to 30 minutes	4

Mode 3 charging

Mode 3 charging is also carried out with a mains voltage of 230/400 V, but it provides for some control and communication functions between the vehicle and the charging station (EVSE: Electric Vehicle Supply Equipment). Normally this method is used for charges up to the semi-fast level (22 kW), but it can be extended for fast charging 43 kW. An additional conductor between the vehicle and the charging station (pilot conductor) is necessary for mode 3 charging: specific plugs equipped with additional contacts are needed (these connectors are covered by Standard IEC 62196). The specificity of mode 3 charging aims at ensuring greater safety, as well as the proper working of the charging process. Amongst the main distinct functions of mode 3 charging are the following:

- Permanent verification of the correct connection of the vehicle: supply of the socket is conditioned by the correct connection of the vehicle (consequently a socket with no plug inserted, unlike a common socket, always lacks voltage, causing serious safety issues)⁷⁾
- Permanent check of PE continuity: in the case the PE is interrupted supply to the socket is cut;

- Charge power control: the charge power absorbed by the vehicle shall not be greater than that available at the charging station;
- Movement prevention: the vehicle cannot be moved when it is connected to the charging station;

Other optional functions include the automatic identification of the vehicle and charging authorised by a payment system.

The most common communication protocol, at present, between the vehicle and the charging station, uses a transmission code based on PWM modulation (pulse width modulation). This system is described in Annex A of Standard IEC 61851-1 and covers the basic functions on the basis of mode 3 ("low-level" communication). A new communication protocol, the extended pilot function, originally developed and proposed by ABB, is actually under consideration of Working Group 4 of the IEC Technical Committee with the aim of including it in the next edition of the IEC 61851 Standard. This new communication protocol, which is based on digital technology, is perfectly compatible with PWM and extends its functions⁸⁾.

⁶⁾ Many ask themselves what risks there would be if a vehicle were to be charged with the same method which supplies a washing machine and if this would be better. A vehicle exposes the people at a large conductive surface and can find itself in the open-air under the rain. These are all conditions which increase risks, especially if the vehicle is being charged in a public place. Furthermore, a vehicle which is able to "hold back" a human body (think of a child chasing a football which ended up underneath the car). Due to all the above reasons, it is considered necessary to provide for additional safety measures, for example the control of the effective PE connection (without which safety decreases significantly).

⁷⁾ Normally an interlocking system is present which mechanically prevents the plug being extracted during charging.

⁸⁾ Other "high-level" communications systems, capable of managing numerous additional functions, are still in the process of being defined in the ISO/IEC 15118 series Standards.

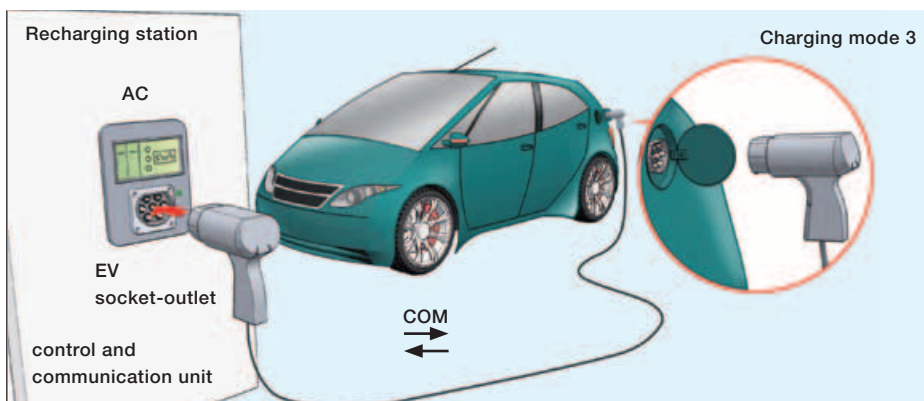

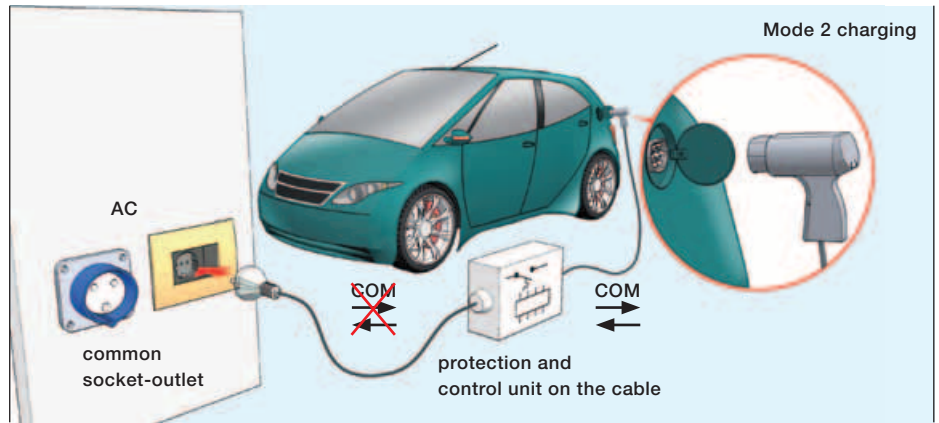

⁹⁾ For method 3 charging stations over 32 A, instead, the connection cable is permanently fixed to the station (Case “C” connection) In this case the inlet is found only one side of the vehicle (vehicles fitted for this type of charging already use a single type of inlet). A third type of connection, Case “A”, which has a cable permanently attached to the vehicle, is mainly used for light vehicles.

¹⁰⁾ The specifics of this portable safety device will subject to Standard IEC 62752, which is currently being drafted.

The column or wall-mounted charging station, can be located on private location, in a public or semi-public area (such as an apartment block car park or a company forecourt). Usually, the charging station also includes the necessary safety systems (MCB and RCD) and a energy meter if any. In the case of private property, the charging station can be supplied by the pre-existing meter (if it is powerful enough), or else an independent device with its own meter can be created. In the case of public areas, there should be a user-recognition system, or a payment system which authorises the charge.

Normally in Europe, the cable between the vehicle and the charging station is completely removable and comes with the vehicle (Case “B” connection), with regards to charging stations of up to 22 kW In this way, by providing each vehicle with its own cable, the issue of the two different formats of inlet currently equipped on electric vehicles is resolved. The standardisation of inlets on European cars is expected from 2017.

It is necessary, however, in order to ensure the desired compatibility between vehicles and charging stations from different manufacturers and different countries, at least that a single format be chosen for the socket on the charging station, at a European level⁽⁹⁾.

Mode 2 charging

It is a hybrid of modes 1 and 3. It is used when a vehicle which is normally fitted for mode 3 charging must be charged by using a common socket. An ICCB (in-cable control box) or an IC-CPD (in-cable control and protection device) equipped cable is used, which assumes the functions of control and residual current protection⁽¹⁰⁾. In essence, it is a portable charging station. This charging method is prevalently aimed at household charging and for emergency or occasional use.

06 AC wall-mounted charging system for electric vehicles, 22 kW ABB charging station (mode 3) and 50 kW ABB DC charging station (mode 4)



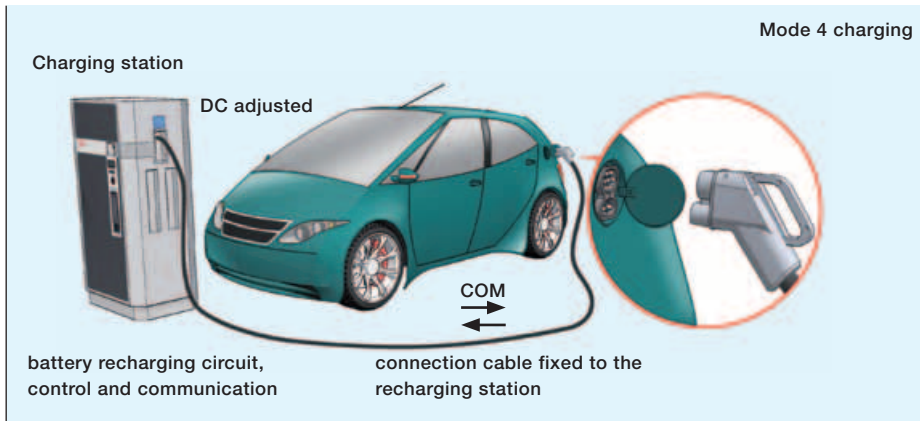

Mode 4 charging

In modes 1,2, and 3, the battery charger circuit is on-board the vehicle and is directly supplied by the 230/400 V AC. In mode 4 instead, the charger is off-board, located inside the charging station. Therefore, the vehicle is charged by DC according to the actual charge voltage of the batteries. Voltage is adjusted by a control system placed on the vehicle, which is capable of controlling the battery charger by remote, by means of a suitable communication protocol. According to the system in use, the charge voltage can be anything up to 1000 V and the current up to 400 A. It is the most suitable method for fast or ultra fast charging. In fact, for very fast charges, it is not a good idea to place the voltage adjustment and rectification circuit on board vehicles because of the weight and the loss of space. The systems currently available can reach 50 kW of power. However, it is expected that with the development of batteries suitable for very fast charging, that ever increasing charge speeds will be possible and that you will eventually be able to “fill it up” with energy by connecting to a charging station for a few minutes.

In mode 4 the charging cable is permanently fixed to the station and therefore the inlet is only on the vehicle (case “C” connection). Vehicles which have been fitted for fast or very fast charging using mode 4, are usually equipped with an on-board small battery charger to maintain compatibility between traditional AC charging stations (modes 2 or 3), which operates with a lower charging speed¹¹⁾.

Very fast DC charging stations are evidently very much more complex and sizeable than AC stations. Even the inlet poses serious technological problems, since it has to carry currents of hundreds of amps, as well as control signals. Fast charge DC stations are intended mostly for electric “service stations”. In fact, the design aspect of these powerful charging stations is similar to that of petrol stations. It can be soon expected that with the distribution of the DC technology and the subsequent reduction in costs, that mode 4 charging can be used for slower charges.

¹¹⁾ An exception could be made for taxi fleets, public transport and commercial vehicles, which could use separate stations.



¹³⁾ CHAdeMO is an acronym which stands for CHarging de MOVing. But also the beginning of a sentence in Japanese: “O cha demo ikaga desuka”, which means “let’s have a cup of tea during recharging” to underline the speed with which recharging is achieved.

In the case of mode 4 charging, even more than in mode 3, perfect compatibility is necessary between vehicles and charging stations in order to ensure completely interoperability; a level of compatibility which not only includes the dimensional form of inlets, but also the sophisticated communication protocol.

The most common system used for mode 4 charging is CHAdeMO⁽¹³⁾, suitable for charges up to 62.5 kW (500 V, 125 A): a 10 minute charge results in a 50 km range.

Usually the vehicles are equipped with two separate inlets, one for DC fast charging and the other for AC slow charging to allow charging when a fast charge station is not available. In the coming years another system, the Combined Charging System, will be used for fast charging. It is based on a single inlet an AC/DC “combo” suitable for both charging in modes 3 and 4.

The concept of “roaming”, which is similar to its namesake in mobile communications, is linked to interoperability between vehicles and charging systems in modes 3 and 4. It is possible for a



subscribing customer to charge his/her vehicle with a determined service provider and in stations belonging to other providers. As with mobile telephone communications, technical compatibility of devices is not enough, you need agreements between service providers, regulation on both a national and international level, procedures and rates.

As well as the charging modes already in use, as mentioned above, we list the following methods which are still in the experimental phase and are awaiting standardisation:

- “Wireless charging” (inductive, capacitive, etc.): the vehicle is charged without inlets nor cables, by means of suitable plate located on the road surface of car parks (this type of charge involves a certain level of energy dissipation however)
- Inductive “paddle” charging: it involves inlet inserts without electrical contact;
- “Battery swapping”: involves automatic rapid replacement of batteries at purpose-built and robotised exchange stations;
- Non-regulated DC charging (fixed battery voltage): this will become an interesting option when LVDC grids are developed;
- Extra low voltage safety charging for electric bicycles, light vehicles, etc.



Ancient energy and modern automation

Efficient and sustainable solutions for a riverside hotel

Silvio Della Casa: Trade Press Relations - LP Division



For centuries and up to several decades ago, complex gear systems put machinery for the most diverse uses into motion, such as watermills, machines for processing grain into flour and grinders for the production of clogs.

Currently, a modern Building Automation system manages a four-star hotel in a green part of the Brianza area just outside Milan - Italy. It would seem nearly impossible, but the energy source which put the old machinery in motion and which today supplies the modern building automation system is the same; the flow of the river Lambro which activates the watermill in "Baggero di Merone" as mentioned in Statute of Waterways and Roads in the County of Milan from the first half of the 1300s.

The decision makers of this unusual and perfect continuation between a distant past and a forward looking present are the owners of the "Il Corazziere" Hotel in Merone, in the Province of Como, who have been restaurateurs and hoteliers since three generations.

In fact, the history of this hotel begins in 1919, when Giuseppe Camesasca, a cuirassier in the army of Victor Emmanuel III, decided to open an inn in the hamlet of Baggero, near the old watermill which thanks to its four metal wheels, allowed many activities in the small village.

From that time the structure has grown, notably with the acquisition, at first, of thousands of square metres of parkland surrounding the restaurant, then of an old adjacent farmhouse which had been transformed into an hotel and, finally, with

the construction of a new building located between the bend in the river Lambro and the irrigation canal which supplies the mill. The hotel is located in this building, which was built with the utmost attention to the real requirements and priorities of guests and by integrating the most modern technological solutions, which include the KNX building automation system supplied by ABB.

The owners started up another initiative, which goes beyond the simple development of the hotel, the acquisition of one of the four mill wheels and the relevant buildings, where, rape oil was produced up to 50 years ago, with the aim of creating an educational and museum area and to use the hydraulic energy of the mill wheel to supply the electric energy to a significant part of the hotel complex.



01

The ancient roots of innovation

The restoration project in relation to the Baggero water mill won a prize for innovation awarded by the President of Italy, for having reinterpreted the ancient use of water in a modern and innovative way, combining it with many cultural, health and sustainability factors.

In fact, the restoration began with the building in a state of abandonment and decay, but with the machinery, transportation systems, gears, accessories and even the jute sacks for grain all intact, as the previous owners had left it.

The idea of developing a multiform project which was not limited to the simple expansion of hotel services, but which entailed restoring the machinery to working order for educational and tourism purposes, came about from the observation of the above elements. Furthermore, the area thus restored is earmarked to be the location for specific cultural initiatives aimed at bringing back the knowledge of certain work processes which made history and shaped the local economy, thanks to the local river, without omitting activities related to the culinary and wine-making traditions of the Brianza area.

As far as the miniature hydro-electric system which uses the energy potential of the old mill for the supply of hotel systems is concerned, the good and constant flow of the river currently allows for about 40 MWh per year of electricity, which is sufficient to meet the requirements of nearly half the hotel structure, with significant environmental benefits which correspond to an annual reduction of over 20 tonnes of carbon dioxide emissions.



02

A very “green” hotel

The “Il Corazziere” hotel is situated in a very green location. Continuity with the surrounding area is maintained even in the construction of the new building, which has the classical shape of farmhouses found on the Padania region, with balconies running along the outside wall, on the river side and a red terracotta tile roof. The ground floor has many open arcades, which were reproduced in rural architecture, which however in this case are needed to optimise the lighting of the public areas inside the hotel.

The products supplied by ABB, that is to say the building automation system and all the equipment and switchgear for low voltage power distribution, are an integral part of the project, which has been developed according to precise ecological and energy efficiency criteria, thanks to which the building has obtained a class A Energy Certificate.

The use of energy produced by the old mill is, in fact, only one of the “eco-friendly” aspects taken into consideration for the new structure which is equipped with a high-efficiency heating and cooling system based on a heat pump, along with a high level of insulation, thanks to the five sheets of rock wool, the REI 45 doors and insulated windows, which also reduce external sound levels in the rooms by 40 dB.

- 01 The old mill at Baggero, back in service after 50 years, it supplies sufficient energy for nearly half the requirements of the hotel.
- 02 A grindstone of the old mill. Restoration will put the machinery in working order again, for educational and tourism purposes.



03

03 The building automation system helps ensure the highest level of comfort in the rooms and the public areas.

The building automation system allows rooms to be managed by a card transponder system, which is programmed when the guest arrives to allow access to the assigned room. The same card, which is then inserted in the correct slot inside the room, turns on the lights and the other electrical devices. Temperature management is organised in such a way to obtain optimal comfort levels without excessive energy consumption; it is based on pre-programmed set-points which can be adjusted by a few degrees more or less by means of local thermostats. The system is programmed to switch off the air-conditioning if a window is opened, making the system even more efficient.

The system can be managed from reception by means of video pages which signal issues in relation to each room, for example vacant/occupied, bathroom alarm, state of the systems, etc.

Even lighting in public areas is controlled by the building automation system, for greater energy efficiency. The brightness of the lighting, is in fact adjustable, thanks to sensors managed by the system, it is maintained at a constant level during the day in accordance with the natural light coming in from the outside, ensuring the highest level of comfort without waste.

ABB technology has been successfully applied to the hotel.

Our thanks to Mr. Andrea Gamasca, owner of the "Il Corazziere" Hotel in Merone.



D Line time switches. Always in time to meet your needs.



An exclusive design, with a backlit white LCD display, plus an extremely ease of use thanks to the only four push-buttons and multi-language text menu formed by two lines of text, make D Line products ideal for automating the functions of the installation. Simple and intuitive programming allows D Line to easily handle the most different commands. With zero cross switching, D Line enables the switching of higher loads and extends the life of the built-in relay. D Line can also manage public holidays, which can be programmed for periods spanning different years.

www.abb.com/lowvoltage

Power and productivity
for a better world™



Improve supply continuity in low-voltage installations through selective main circuit-breakers!

Electricity is the most important form of energy in today life. Therefore, any low-voltage electrical installation has to be safe and reliable. The continuous availability of electricity is getting more and more important in industrial, commercial and private environment.

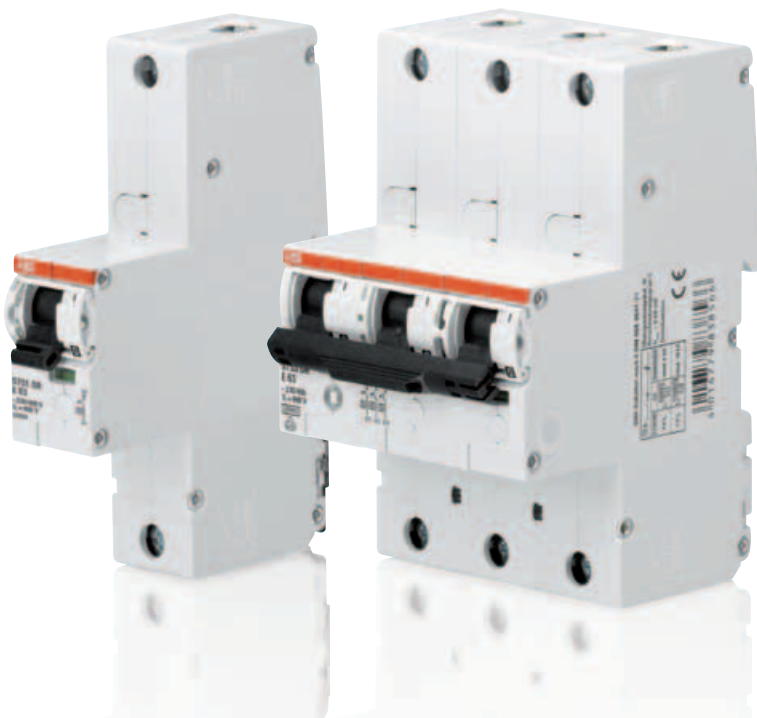

Electricity plays an outstanding role in the technical infrastructure of public and private buildings. Electrical energy is supposed to be available every time and (nearly) everywhere. Beside the supply of appliances directly used by people, electrical installations are of high importance for the operation of any other technical system, like HVAC, safety related services and also all kind of energy efficiency measures in a building.

Knowing this, it is evident that the distribution system for electrical energy has to meet a high degree of continuity without neglecting protection aspects– and ABB has the complete range of products for a safe and reliable installation!

Since the electrical installation inside a building is a more or less complex system for distributing energy from the supply to any connection point for current using equipment, considerations have to be made for the correct design of circuits and for the selection of electrical equipment. Depending on the size and the purpose of the building, there are several branches in the electrical wiring system with a change of cable sizes, cable types and wiring methods. Normally, each branch requires a protective device to reduce the effects in case of overload and short-circuit. The correct coordination of these devices is essential.

With the technology of Selective Main Circuit-Breakers (SMCB) ABB introduced some 30 years ago a type of circuit-breaker, which enables on the one hand best overload protection for cables due to the unique tripping characteristic close to the rated current (leading to the highest degree of utilization of a given copper size), and on the other hand total selectivity to any downstream MCB installed for the protection of final circuits. Even the selectivity to upstream devices is improved compared to other types of circuit-breakers due to the unique current limiting selectivity. So, in case of a failure, only a small part of the installation up to the directly associated protective device will be disconnected from the supply – all other circuits upstream or in parallel are not affected.



Bernd Siedelhofer
Installation Technology Manager
LP Division

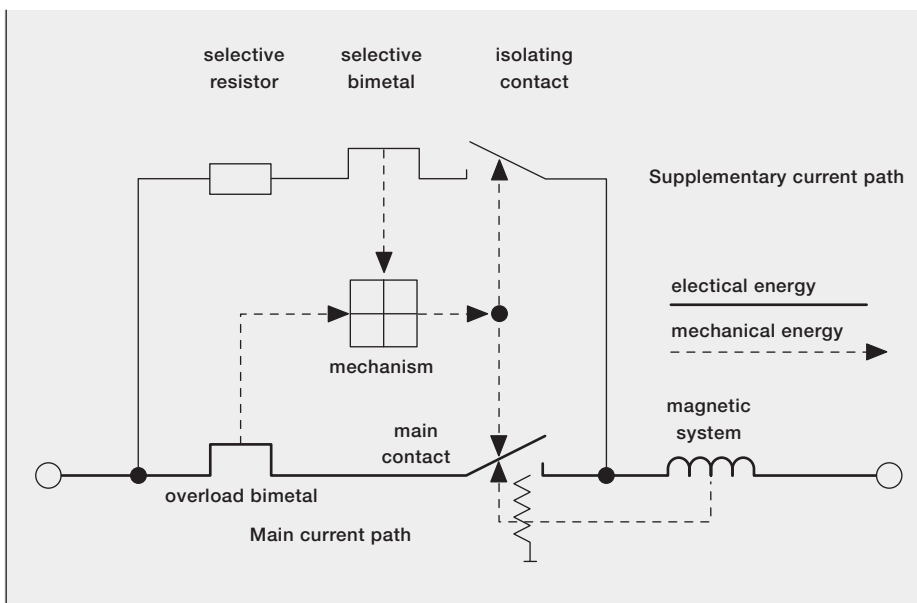

SMCBs from ABB have a high degree of isolation capability. Beside selective overcurrent protection of cables they can also be used as a main switch for isolating purposes in any installation category. Consequently, SMCB are the perfect protection also for smissline distribution systems. They are designed to be operated by unskilled people and fulfill the requirements for overvoltage category IV and pollution degree 3, which enables the installation also close to the origin of installation.

ABB started the SMCB line with the product range S700 which was commonly used for the selective protection in main distribution boards in buildings, e. g. in meterboards. Some years ago, this range was extended by a new range of S750 SMCBs, which is now available as S750DR (DR = DIN rail mounting) for multi-purpose applications in any kind of distribution board.

The S750DR range covers the tripping characteristics $E_{selective}$ and $K_{selective}$ and all commonly used pole variants. The devices are tested and approved based on dedicated SMCB product standards like VDE 0641-21 and GB 24350. For international reference, the SMCB family is completed by a range based on IEC/EN 60947-2.



The importance of energy saving starting with a twilight switch





The correct use of twilight switches is the ideal solution to cut consumption and pollutant emissions of public lighting systems.

Francesca Sassi: *Product Marketing Manager - DIN Rail Products*

How many times have you admired the reflection of the dawn and the clarity of its light? How many times have we stopped, mesmerised, to look at the wonderful colours and the beauty of a sunset or to wonder about its magic? These are amongst the most fascinating phenomena that nature can offer, they bring out our more romantic and less emotional side.

As technicians, moreover, we are inclined to find a more scientific definition for twilight, due to professional training and necessity. Finding an exhaustive definition is, however, is not banal in the least. The problem dates back to more than two thousand years ago. On the one hand, the necessity to find a definition for natural phenomena and the need for societies to use daylight hours on the other, has driven scholars, down through the centuries, to define and capture twilight. The ancient Romans called it “crepem” or “nearly dark”. The ancient Greeks called it “amphi-luce” or “doubtful light”.

Even today, not so differently from two thousand years ago, it is evident that there is a lack of a universal definition upon consultation with the scientific community. “A sunset is an intellectual phenomenon”, according to Francesco Pessoa. Twilight, is in fact, complex and difficult to define, since it is influenced by multiple factors,

such as latitude, season, month, weather conditions, transparency of the atmosphere and declination of the sun. On a scientific level there are three distinct definitions of twilight, which are astronomic, civil and nautical. It is ascertained on the basis of the inclination/depression of the sun in relation to the horizon, keeping in mind the degree of visibility of objects and stars. The civil twilight, particularly, is defined by the time interval in which the sun shows a depression of between 0° and 6° . In reality, when the height of the sun is equal to -6° street lighting is turned on.

The exact definition of twilight in relation to time, is today indispensable, even from an energy saving point of view. In fact, it is even more important to adopt technologies which allow for a reductions in consumption and pollutant emissions, ensuring contained costs at the same time.

From this point of view, the crucial question is whether a device exists which can program the turning on/off of street lighting or lighting in shop windows based on the quantities of available sunlight, without having to monitor or to perform any actions on a daily basis? Is it possible, rather, to have an effective assessment mechanism, which regulates, independently from location, season and weather conditions, the operation of a lighting system?



01

- 01 An example of a domestic consumer unit with a TW1 twilight switch.
- 02 The ABB range of TW twilight switches.

The answer is yes. This is achieved by twilight time switches, which are devices designed to control and manage charges in relation to ambient light detected by the correct sensors. The twilight switches determine the turning on of the lights in a system when the registered light level falls below the set threshold. It has been agreed that the threshold is defined at 10 lux (unit of measure for light intensity). The twilight switch ensures, therefore, regular light conditions over time, which are established in an objective way and which do not need daily programming, being capable of following occasional and temporary changes to sunlight. All the above allows for large reductions in energy consumption.

ABB proposes a series of twilight time switches which include various functions for special requirements. The standard range of TW1 switches, pre-set in the factory at 10 lux, are used mainly in public street lighting. The TWP range is also available, it has the same functions, except is more suitable for installation on poles. These devices entail a switching delay, which avoids premature intervention in the case of an untimely change in the level of light intensity. For daytime applications with high light intensity values, ABB proposes

the TW2/10K range supplied with an three-point adjustable threshold.

In spite of the certain benefits of the use of a twilight switch, it is possible that other phenomena are detected by the sensor, for example smog or prolonged light pollution. In areas affected by such phenomena, a twilight switch would not be efficient. In these circumstances it is more appropriate to opt for the installation of a twilight astronomical switch, such as those from ABB's TWA-1 and TWA-2 ranges. This device regulates the turning on of a system on the basis of when the sun rises and sets, without the help of sensors and in relation to latitude and longitude parameters of the location where it is installed.

A possible development in the design consists of the synchronised use of an astronomic switch connected to a twilight switch: in this case, the first switch determines the actual time interval and constitutes the out-out for measurement, by the sensor, of light intensity. This type of combination, on the one hand, ensures the proper operation of the switch at the right time, avoiding alterations caused by light pollution and furthermore allows the device to work even when the sensor has been damaged.

Public lighting in Italy accounts for a 3% share of a total annual consumption of 340 TWh. This corresponds to a total annual costs of 1500 million EUR (about 25 EUR a year per person). Furthermore, it must be considered that the cost for public lighting has increased by 0.0816 EUR (January 2005) to 0.15 EUR (December 2010): an 83% increase in 5 years¹⁾. By assessing the costs of a public lighting system for a lifespan of 10 years, it emerges that 36% of the total cost is down to electric energy consumption and 6% for the maintenance of often obsolete systems.

The twilight switch, is currently, used in nearly 55% of Italian systems, whilst the astronomic switch is, at present, used in 13% of towns and cities. Consumption of electricity due to lighting has risen by 19% on a world-wide scale. In Europe, nearly a third of street lighting is based on systems which uses obsolete systems and the annual replacement rate is about 3%²⁾.

The correct use countrywide (and worldwide) of these devices, a correct preventative maintenance, along with sensitization of the private sector, would constitute a notable saving for administrations and private citizens alike. In a more general fashion, the use of lighting systems with new-generation technologies would allow for energy consumption and costs to be reduced by about 85% with a pay-back in 5-10 years.

Monitoring and optimising thus becomes fundamental in relation to energy saving and the protection of the environment. Particularly in the case of public lighting, which represents an obligatory task for local administrations, which is without any direct return, it is necessary to improve energy management. The application of ABB twilight switches is particularly useful in public places (gardens, car-parks, entrances, courtyards, etc.) and allows for a notable reduction in consumption. Furthermore, it has been proved that the reduction of public sector costs in relation to the correct use of energy efficiency technologies, is also apparent in the private sector. In this way, energy efficiency becomes synonymous with savings and well-being both in the public and private sectors.

¹⁾ Ecoscienza, Issue no.2, 2011

²⁾ National Programme for green public procurement - PAN GPP- report

³⁾ See previous note

⁴⁾ See previous note

02



UL 1077 and UL 489 differentiation

Very often we receive inquiries for components that need to comply with UL standards. In connection with MCBs these are commonly UL 489 and UL 1077. How to know when you must refer to the first or the latter?

Florian Krackhecke: Product Marketing Manager - DIN Rail Products

In order to understand it is necessary to know about two factors:

1. The separation of an electrical distribution into three main sections

Generally an electrical distribution system can be separated into:

- a) **Feeder circuit** – the feeding area of a distribution before the first protective device
- b) **Branch circuit** – the area from incoming terminal to outgoing terminal of the underlying branch circuit protective device
- c) **Supplementary circuit** – the area from the outgoing terminal of the branch circuit protective device via the supplementary protector to the load

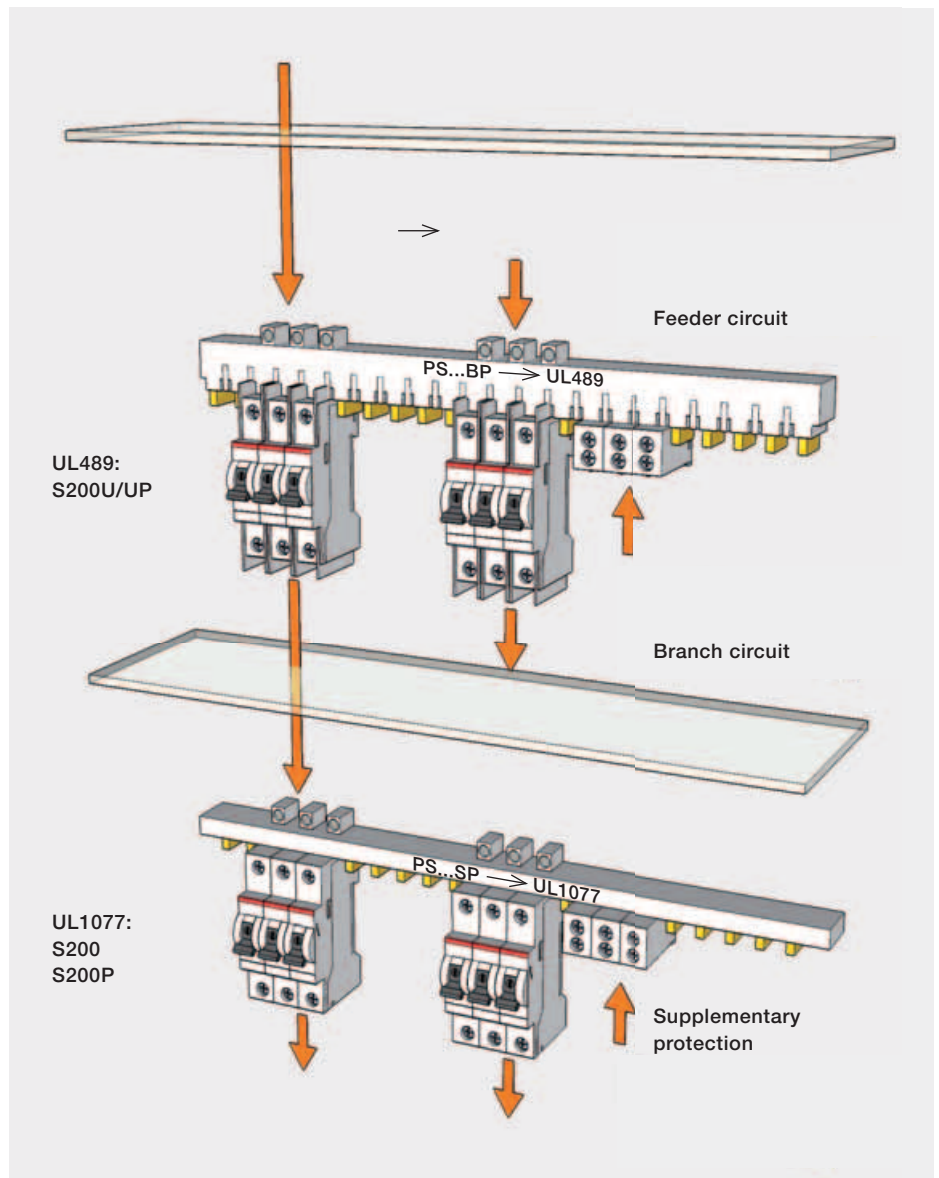

2. Clearances and creepage distances

UL approved MCBs must be designed for voltages of up to 480 V. Regarding adjacent devices it must be ensured to avoid mutual interaction – worst case here: the electric flashover. In order to avoid this phenomenon, UL approved MCBs are characterised by a special design in the terminal area, preventing from a flashover via surface or air.

As the branch circuit protection device is the first device after the feeder circuit the requirements are higher than for a supplementary protector.

The requirements for branch circuit devices are defined in the standard UL 489. These circuit breakers are specifically intended to protect and to break the branch circuit itself. It must be possible to manually break and reclose the circuit and in case of a tripping due to an over-current and the breaker has to fulfill specified tests afterwards. Circuit breakers in the terminology of the Underwriter Laboratories (UL) are Moulded Case Circuit Breakers (MCCBs) and fuses.

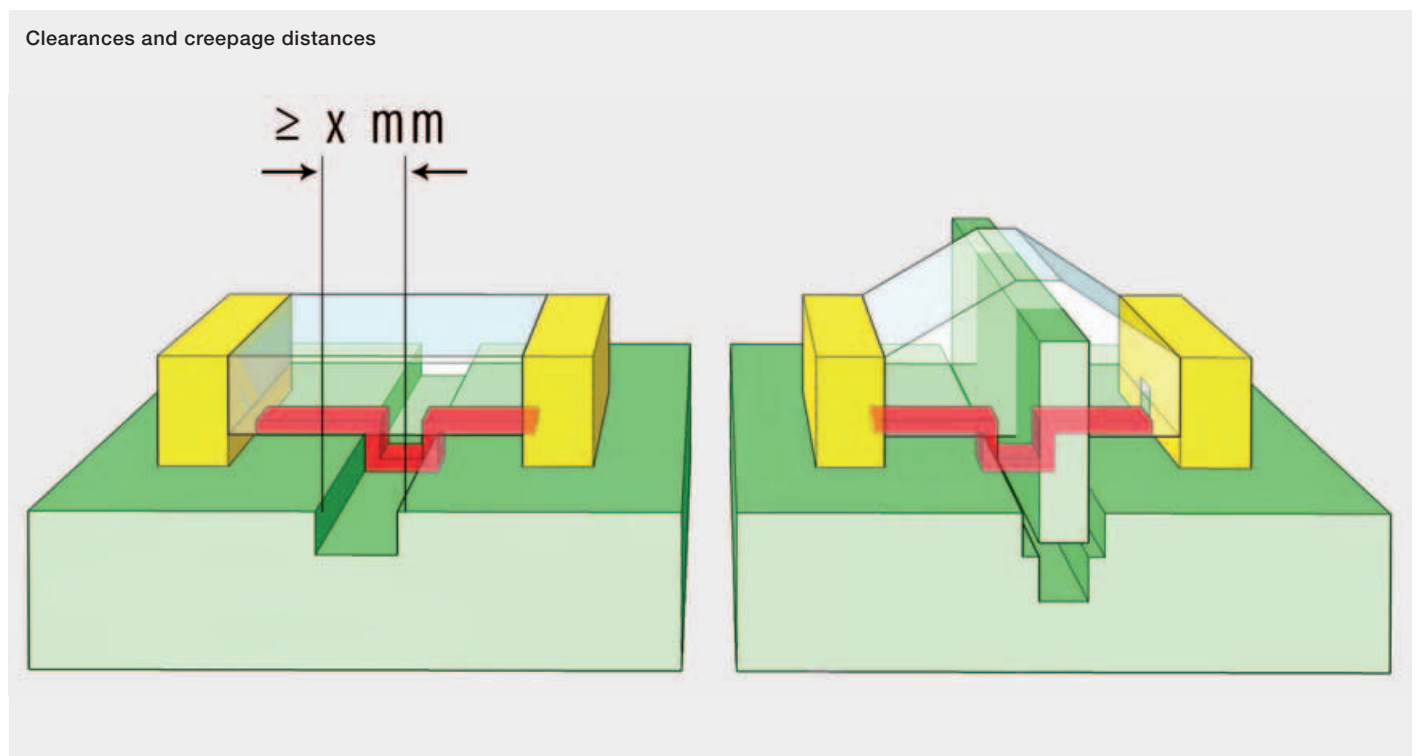

- Red: spacing over surface or creepage distance
- Blue/clear: spacing through air or clearance distance
- Yellow: live parts

The requirements for supplementary circuits are defined in UL 1077. These circuit breakers are specifically intended for the use as overcurrent protection in applications where branch circuit protection is already provided. The circuit breakers are installed for the protection of control circuits and loads such as motors, lighting circuits etc.

Now it becomes clear why, in contrary to supplementary protectors, branch circuit breakers need to meet more severe requirements. Design-wise they are characterised by special barriers in the terminal area, indicating the fulfilment with the standard UL 489.

Supplementary protectors complying with the standard UL 1077 do not necessarily have to be equipped with barriers but need to prove an appropriate protection against electric flashover as well. The supplementary protector must always be backed up by a UL 489 breaker.

Typical network systems in the north America region:

- 1) 120 V single phase (without barriers)
- 2) 120 / 240 V single phase, 3 wires, grounded midpoint (small barriers)
- 3) 240 V 3 phase delta, 3 wires, grounded corner (small barriers)
- 4) 277 / 480 V 3 phase Y, 4 wires (large barriers)

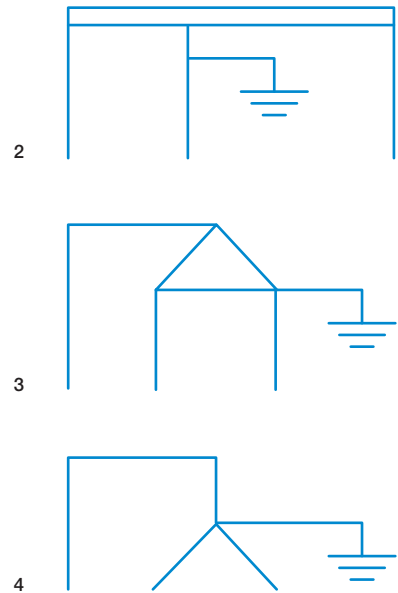

Comparison			
	UL 489 MCBs		UL 1077 MCBs
Types	S200UP	S200U	e.g. S200
Branch protection	■	■	-
Supplementary protection	■	■	■
Voltage level	480Y / 277 V AC	240 / 240 V AC	480Y / 277 V AC
Barriers	high	low	-
Standalone use	■	■	- (only with UL 489 device upstream)

MCB versus a rubber duck

A not really fair comparison

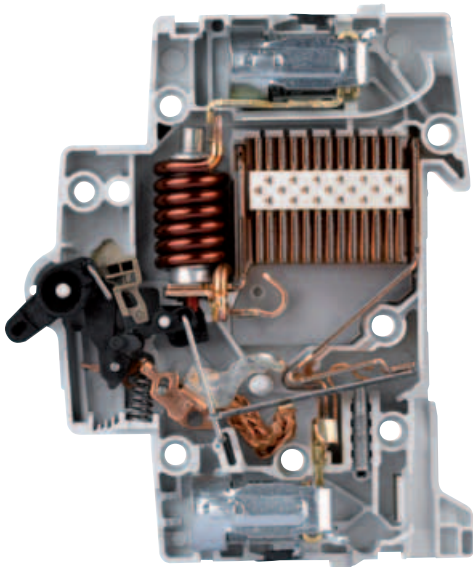

VS



The miniature circuit breaker, first invented by Hugo Stotz in year 1923, in fact is a true masterpiece of electrical engineering. Totally 40 assembly units – consisting of 60 component parts – are designed to interact with each other, purely mechanically and in total harmony, in order to literally swallow that harmful amount of energy from an electric system that would normally destroy cables and electric appliances in the event of an overcurrent. Taking that burden all alone with the only result of nothing but “hot air”. And the best: the MCB overcomes that situation without damage to itself remaining functional for the next job. Isn't that great? By the way, already Hugo Stotz' first MCB was able to perform like this. But enough of this philosophical approach.

It's high time to do Hugo Stotz and the MCB the honour of protecting from short circuits and overloads for almost 90 years now. 90 years in which the miniature circuit breaker has undeservedly degenerated to a commodity product.

Let's honour the MCBs long-term credits by means of a (not too serious) comparison to sensitise again to what is behind this little plastic housing containing a toggle, two screws and some metal inside:

	Rubber duck	Miniature circuit breaker
Component parts	1	ca. 60
Hazardous material	softener	–
Layman operability	•	•
Quality check method	optically, pinpointed	functionally, one by one
Protection function	–	against overload and shortcircuit
Degree of protection	waterproof	IP 20
Auxiliary elements	–	•
Accessories	–	•
Functional variants	–	> 5.500
Operating temperature	21 to 42 °C	-40 to +70°C
Shock resistance	150 g	30 g
Vibration resistance	150 g	5 g

The rubber duck's retail price is 3,99 EUR...

Overheating in electrical switchgears

Correct control and management of the temperature inside a switchgear is very important to assure a long life to the switchgear and internal components.

Roberto Vanetti: *Product Marketing Manager - DIN Rail Products*



Overheating inside electrical switchgears

The dissipated power of the electrical and electronic equipment is transformed into heat which accumulates inside the electrical switchgears. With regards to electrical switchgears, in addition to this heat source, other elements such as irradiated heat from external or internal sources and heat transferred by contact must be considered.

All the above generates an internal temperature in the electrical switchgear which is greater than the external environment (it is called overheating in relation to the environmental temperature).

The capacity of an electrical switchgear for dissipating to the environment the heat generated inside is in proportion to its dispersing surface and its airtight sealing in relation to the environment (the protection degree of the switchgear).

Why should the temperature be limited inside electrical switchgears?

Excessive temperature inside an electrical switchgear is the cause of wear and tear in internal components with consequent changes in performance, resulting in a shortened working life and poor reliability over time.

Poor reliability over time in safety devices can result in their unwanted tripping or in opposite side in a not trip situation in presence of fault.

Keeping the temperature inside electrical switchgears within the correct limits is considered to be one of the main factors concerning the good maintenance of the related industrial equipment.

Uncontrolled overheating in electrical switchgears is often the cause of breakdowns which cost significantly more than temperature control system.



What the Electrotechnical International Standard states in relation to the components of the electrical switchgear

The International Standard concerning electrical switchgears and the components contained therein, does not fix a limit for overheating but refers to the individual component Standards. These standards mainly fix overheating limits only for equipment terminals in order to maintain the connected conductors. These limits are met in prefixed test conditions which are typically very different from those encountered during installation. Furthermore, such limits do not have a specific link with the degree of functional deterioration of the device, which depends on its internal components.

Additionally, it must be said that a punctual surface temperature value is difficult to correlate with the maximum air temperature inside the switchgear. Therefore, it is necessary to ascertain the behaviour of

internal devices in relation to temperature and to establish the maximum temperature limit at which they can work without affecting future performance.

Switchgear components and their behaviour in relation to rising temperature

As has been said before, the lifespan of electrical components varies according to the temperature in which they operate, the ideal values for components in an electrical switchgear (for which you can consider a minimal level of wear and tear) is between 25°C to 35 °C for common devices.

In real-life, keeping the temperature below +35 °C inside the switchgears would be extremely difficult and it is precisely for this reason the product standards which establish the temperature limits for testing, have fixed wider limits.

For example, the main reference standards establish functional temperature between -5°C and + 40°C, with the pos-

sibility of extending use to -25°C, for modular switches such as MCBs and RCDs. Device manufacturers go one step further, achieving certification levels for higher temperatures, permitting functionality at a maximum level of 55°C.

Maximum internal temperature in an electrical switchgear

The internal temperature of a switchgear must not affect the reliability of the devices contained therein. The maximum internal temperature in a switchgear which ensures reliable operation has been established at 55°C. To exceed this limit would be dangerous, even for the PVC cables which must not exceed 35°K, a temperature of 55°C can be easily surpassed.

Environmental conditions for switchgear installation			
Type of switchgear	Relative humidity	Air temperature	Height
Indoor switchgear	50% (at a maximum of 40°C)	Maximum temperature < 40°C	Does not exceed 2000 m
	90% (at a maximum of 20°C)	Average maximum temperature in a 24 hour period < 35°C Minimum temperature -5°C	
Outdoor switchgear	100% (at a maximum temperature of 25°C)	Maximum temperature < 40°C	
		Average maximum temperature in a 24 hour period < 35°C	
		Minimum temperature -25°C in temperate climates	
		Minimum temperature -50°C for Arctic climates	

01

- 01 IEC EN 61439-1: Environmental conditions for switchgear installation
- 02 Switchgear overheating control system by forced ventilation

Ambient temperature

Overheating in electrical switchgears is obviously subject to the ambient temperature where it is installed and for this reason in the standard for switchgears (IEC EN 61439-1) the maximum air temperature and humidity values are fixed in relation with installation conditions, distinguishing switchgears for indoor and outdoor use. (Figure 01)

In both cases the Standard establishes the maximum ambient temperature at 40°C which is a value not usually exceeded both outdoor (excluding desert climates) and indoor (if not affected by particular conditions such as proximity to industrial processes which generate notable heat).

Indoor switchgear installation

If installed indoors, switchgears must be installed in areas where the room temperature does not exceed 40°C. In the case that the ambient temperature is over this limit it is necessary to segregate the installation area, with an air conditioning system which maintains the temperature under this value. Therefore, it is always necessary to check that overheating inside the switchgear does not exceed

55°C – ambient temperature.

In the case that the above is not possible in relation to high power dissipation of the internal component, it is necessary to equip the switchgear with an overheating control system (see below). Furthermore, it is necessary to check that no heat has been irradiated by external elements or transmitted to the switchgear by contact.

Outdoor switchgear installation

If installed outdoors, the switchgears should not be placed under direct sunlight in order to reduce any negative and contributory effects of irradiation.

In the case that sunlight could significantly contribute to switchgear overheating, it is obviously necessary to evaluate the components (in a switchgear subject to direct sunlight, even with all the components turned off, notable overheating can be achieved!).

Barriers for protection against direct sunlight, such as screens, must be prepared for the protection of the switchgear in such a way that air circulation is not blocked.

The switchgears must not be installed in contact with elements which are themselves affected by overheating. It is also necessary in this case to check that the temperature inside the switchgear does not exceed

55°C – ambient temperature.

In the case that the above is not possible in relation to high power dissipation of the internal component, it is necessary to equip the switchgear with an overheating control system (Figure 02).

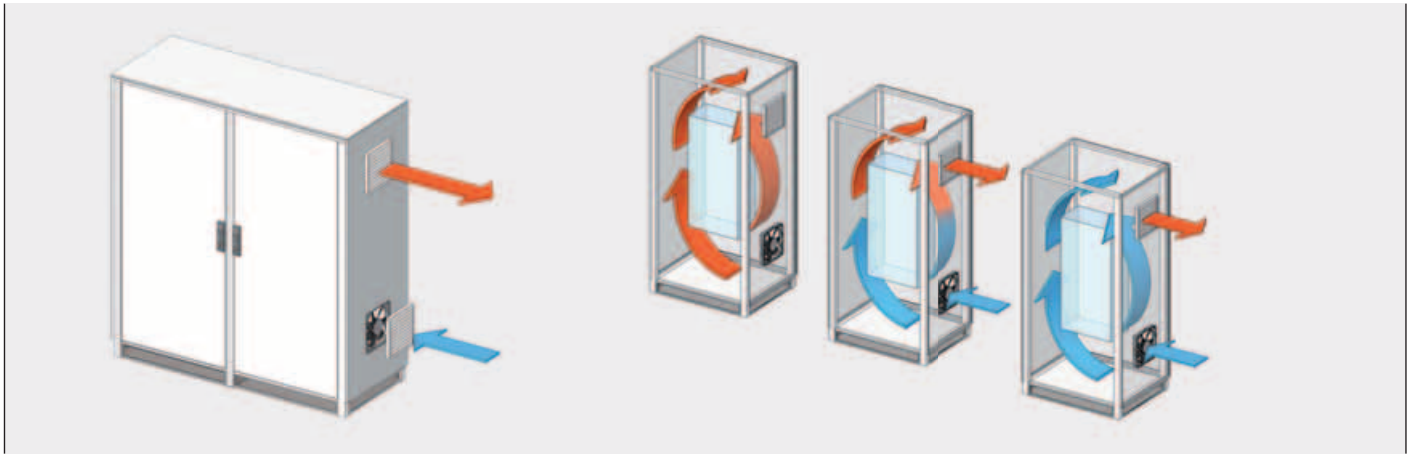

02

Evaluation of switchgear overheating

The calculation for internal overheating in switchgears must be carried in accordance with indications contained in the Standard (IEC EN 61439-1): this evaluation must be carried out by considering the external environmental conditions and the additional heat dissipation from the internal components.

The Standard fixes different temperature limits for different parts of the switchgear, the evaluation establishes the maximum internal temperature for different areas of the switchgear.

Furthermore, due to the fact that heat is focused on dispersive and often manoeuvring devices, the Standard fixes the maximum overheating levels, even at specific points such as on manual control devices and external accessible covers.

If the calculation shows that the temperature inside the switchgear is over 55°C, its reliability over time (the reliability of internal devices) could be seriously compromised, therefore it is necessary to adopt solutions to lower the temperature to within the established limits.

Reduction of overheating inside electrical switchgears

The first step is to check if it is possible to use a bigger switchgear with greater heat dissipation characteristics (larger and therefore with a greater thermal exchange) in such a way as to favour greater heat dispersion.

At the same time, it is suggested to check if it is possible to reduce heat dissipation by selecting internal components with a lower heat dissipation (over-currents, even if transitory, are one of the main cause of heat dispersion).

If after performing all the above actions, the temperature still remains above 55°C, there are many temperature control systems available to limit the internal switchgear temperature.

Cooling systems using forced ventilation constitute one of the most simple solutions for reducing the internal switchgear temperature. Cooling is achieved via forced air ventilation: the system is composed of a fan, equipped with a filter and entry and exit air grilles. The fan, which is installed in the bottom of the cabinet, filters and extracts air from the environment, while hot air is eliminated through a grille installed in the top part. In this way the exchange of air contributes to obtaining efficient heat dissipation.

Furthermore, the pressure generated by ventilation, blocks the entry of non-filtered air from possible holes or cracks. Supply of the fan can be controlled by a thermostat placed in the top part of the switchgear. A protection degree of up to IP54 is ensured by using these systems and the correct grilles.

With this system the temperature inside the switchgear can't be less than the room temperature.

When room temperature reaches a value, which makes the internal switchgear heat management impossible by use of a forced ventilation system, then an air-conditioning system must be applied.

We can have two types of air conditioning systems:

- with air-to-air exchangers
- with air-to-water exchangers.

Conditioning systems using air-to-air exchangers allow for a protection degree up to IP54 and can be used when the external temperature is lower than the maximum internal temperature that can be accepted. (e.g. external temperature of 40°C and max internal temperature of 50°C).

Conditioning systems using air-to-water exchangers allow for a protection degree up to IP55 and can be used when the external temperature is higher than the maximum internal temperature that can be accepted (e.g. external temperature of 40°C and max internal temperature of 30°C).

Conclusions

Limiting overheating in electrical switchgears is necessary in order to manufacture switchgears reliable over time, reducing as much as possible operation interruptions, which are often the cause of financial losses.

A correct design and sizing allows the production of switchgears in which internal overheating remains between pre-established limits, so as not to compromise reliability and lifespan over time.

Particularly, a correctly sized switchgear should follow the following temperature criteria:

Indoor use (ambient temperature <40°C):

- air-conditioned area: maximum internal switchgear temperature of 40°C¹⁾.
- non-conditioned area: maximum internal switchgear temperature of 55°C (exceptionally 60°C for non-continuous use).

External use (ambient temperature <40°C²⁾)

- with protection from direct sunlight: maximum internal switchgear temperature of 55°C.
- without protection from direct sunlight: maximum internal switchgear temperature of 55°C. The maximum temperature of the external metal surface must not exceed 70°C.

For internal switchgear temperatures which are higher than those mentioned above, the degree of wear and tear of the internal components would be extremely elevated and it is therefore necessary to implement a regular maintenance program to replace components, in order to avoid sudden switchgear shut-downs.

The cost of the overheating control systems (e.g. forced ventilation and conditioning systems) is nearly always less than the cost of interrupting operation due to accelerated wear and tear of the components which have to operate at high temperatures for long periods of time.

1) in the case of conditioning system malfunction the temperature must not exceed 55°C

2) in the case that room temperature is higher than 40°C, it is necessary to install it internally.



Roberto Vanetti
Product Marketing Manager
DIN Rail Products



SMISLINE TP. Touch proof system. Power and Safety.

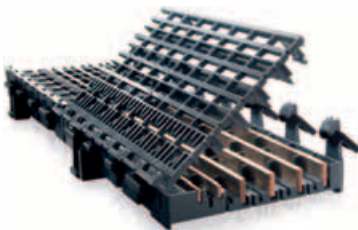

Absolutely safe without protective equipment: SMISLINE TP ensures that load-free devices and components can be snapped on and off under voltage without the need for additional personal protective equipment to guard against electrical hazards. That opens up completely new prospects for you when it comes to installation, operation and flexibility. www.abb.com/lowvoltage



Switching off instead
of blowing.
Make profits with
miniature circuit breakers

For many years the fuse was the best choice to protect man and machine from overcurrent. However, what moved into the consumer units of private households over three decades ago, is now also starting to increasingly establish itself – in a more developed form – in industry, business and transport: the miniature circuit breaker

Sabine Berndt: *Product Manager - DIN Rail Products*

Miniature Circuit Breaker

The miniature circuit breaker (MCB) has been in existence since the 1920s. It is characterised mainly by the feature that it can be switched on again after it has tripped, by simply switching a lever by hand without using any tools. Furthermore it offers consistent selectivity and tripping characteristics over the whole operating period and therefore constant reliability.

Office complexes, airports, solar parks, high speed trains: there's a good reason why this well thought through and robust solution for the protection of power lines is used increasingly where maximum safety and the highest availability is of paramount importance.

Fuses

The „classic“ amongst current overload protection devices. A fuse offers high levels of switching capacity and good current limiting. Apart from having good selectivity features when new, they are markedly cheap when initially used to provide fuse links. Add to this the fuse's most significant characteristic: once it has tripped it must be completely exchanged for a new one.

A miniature circuit breaker can be tested reliably.

It is the nature of the thing: when a fuse is produced only random tests can be carried out and tripping efficiency checked. A function test is impossible, as this would destroy the fuse. In practice, we can rely only on a spot test when checking the fuse for statistical protection. However, those who want to check the quality of an overcurrent protective device not only by means of optical inspection, simple continuity tests or shaking, rely correctly on miniature circuit breakers: These are always tested pole to pole in the factory and are calibrated. The function of an ABB High performance MCB S800 can be checked at any time via the test button, even when built in. This offers maximum safety. Indeed, at any time.

Guaranteeing excellent operator safety

Most accidents involving electricity do not have a technical cause! Aluminium foil wrapped around burnt-out fuses, a finger in the fuse socket, the pulling of fuses by force without safety equipment, a discharging metal wrist watch or the common mentality „let's just leave it“ – all contribute to the findings of the Institute for the Investigation of Electrical Accidents in the Trade Associations Energy, Textiles, Electrics and Media Products, that around 85% of all reported accidents involving electricity even happen to qualified electrical personnel.

Therefore, electrical accidents happen especially often in low-voltage distribution. It is not surprising that arc accidents are named as the third significant cause for electrical accidents considering the recently popular use of fuses in photovoltaic installations. In particular, the high levels of DC current in photovoltaic installations can create dangerous arcs when fuses are inexpertly changed without first operating the disconnecter. And this happens despite the fact that miniature circuit breakers for the safety of wiring for photovoltaic installations have been available for several years, which can remove this safety risk with a click once and for all. Another benefit of the miniature circuit breaker: It eliminates the risk that a fuse with the wrong current rating is installed – which is quite possible in the fuse sockets of generator junction boxes.

It is a fact that safety guidelines are not always observed when fuses are changed and that safety equipment is often avoided. Furthermore, the everyday practical exchange of fuses always carries a risk – which simply just does not exist when you comfortably switch the toggle of a miniature circuit breaker to remedy a fault.



Disconnecter properties combined with safety

A burnt-out fuse cannot disconnect. A disconnecter must be fitted in front when it is not already integrated into the fuse socket. This takes up more space on the DIN-rail than a miniature circuit breaker with disconnection features – an appliance that can do both: protecting and disconnecting.

Fuses change their properties

This is often neglected with fuses: they are subject to an aging process. Levels of efficiency with regards to selectivity or Back-Up can only be determined at one point and always only refer to a new fuse – as power surges during its lifetime can change the fuse's ability to react. A fuse is unreliable, as the fusing process determines the operating time of disconnection. It has been reported that even sudden changes in temperature without overload or short circuit can cause the fuse to blow.

Miniature circuit breaker: Constant efficiency over its lifetime

A miniature circuit breaker guarantees years of consistent efficiency. Each pole is secured individually; in case of faults it switches all poles off and all trigger features remain reliable throughout. Over its entire lifetime.

Efficient and ecologically safe Investment with sustainability factor

Environment friendliness meets cost efficiency

Burnt-out fuses must be disposed of. A triggered miniature circuit breaker can be switched on again, comfortably and safely, when it has tripped - even by remote control, which is invaluable especially for solar power stations and wind farms.

Another plus for the environment is that circuit breaker components can be easily recycled, and that the miniature circuit breaker saves space.

Faster operating, avoiding stoppages and long journeys

A burnt-out fuse must be replaced. You are forced to store an appropriate replacement. If you are lucky you can purchase it, if you are unlucky it is not easily available in the country where the unit is being operated and therefore causes unacceptable delays.

Furthermore, appropriate safety equipment must be available during the exchange which, above all, has to be available. This causes further hold ups in production in these cases.

It is often difficult to ascertain that a fuse has burnt-out. And a burnt-out fuse generally has no remote control tripping sig-

nal. This, however, can be easily realised when you use a miniature circuit breaker by installing an auxiliary or signal contact; its switch position is always clear.

Modern miniature circuit breakers such as the High Performance MCB S800 have a 'TRIP' position. Resetting the miniature circuit breaker is also possible by hand without any tools. Modern equipment series also offer remote control units.

Low maintenance costs determine the favourable start-up price

This is a statement often made by electrical planners:

"Installations without fuses are a problem of investment. If the customer does not especially demand a miniature circuit breaker, my competitor will always be cheaper. Everyone wants safety, but does not want to pay more for it."

The often low initial cost of fuses may make this statement sound correct, at first. However, often neither the cost of the fuse box nor the continuous on-costs during the lifetime of the equipment – the so-called Total Cost of Ownership (TCO) – are considered. This does not just mean the costs for a certain amount of spare fuses, transport or personal safety equipment. The highest cost difference between miniature circuit breakers and fuses is the much lower downtime of the electrical

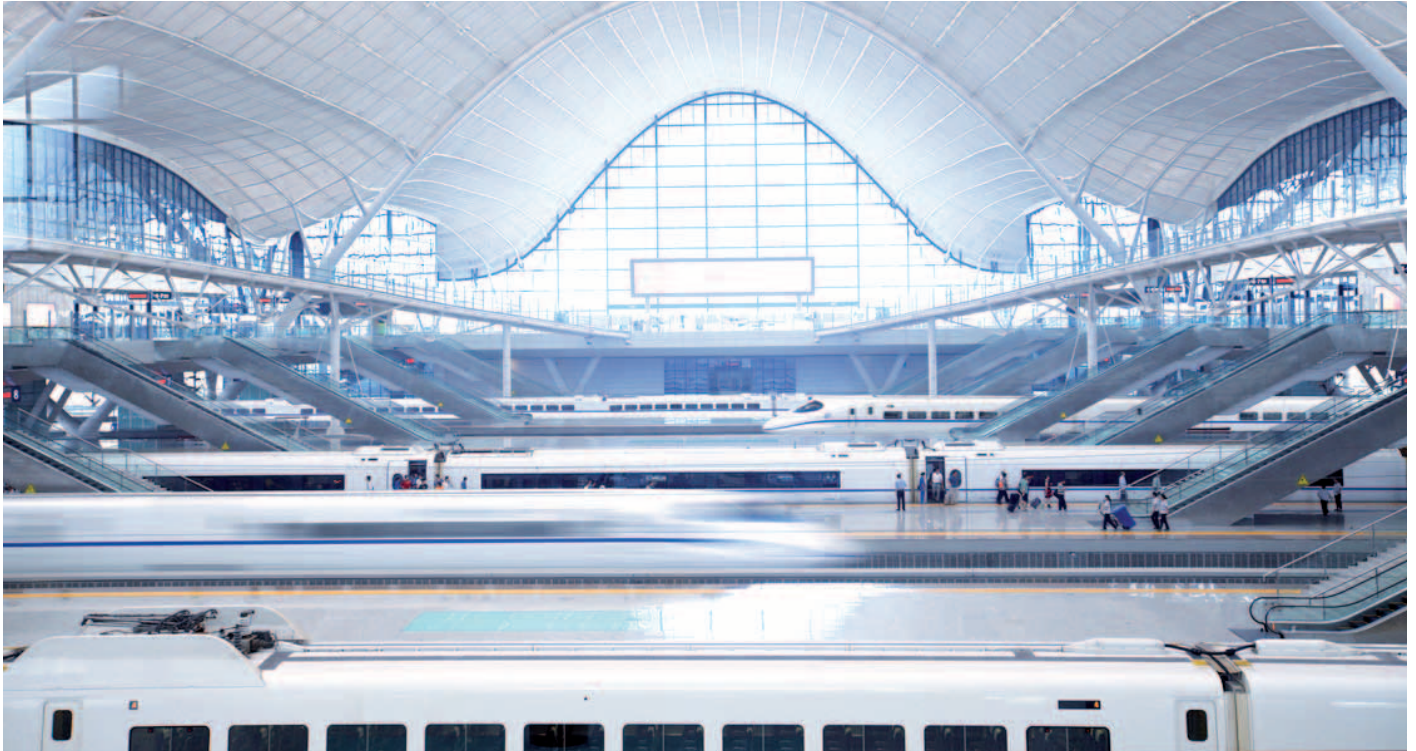

appliances connected to the circuit. Profits lost add up to gigantic sums for companies, especially for commercial and industrial low voltage circuit users. The Internet offers Online-Calculators to work out profits lost due to downtime. Non-available mobile telephone stations cause losses of profit of over 600 EUR per minute, a stock exchange system that does not function deficits the accounts by more than 120'000 EUR per minute. Costs, which in the first place don't even occur when a MCB has tripped and its investment cost soon balance out. Circuit protection management with miniature circuit breakers ensures that even in times of low charge returns in a photovoltaic installation the greater cost compared to fuses can be written off within the first hour of the first fault.

Be sure to make a good decision
Good reasons for a miniature circuit breaker
Win-Win-Win-Situation with miniature circuit breakers

The operator of an installation

The operator increases his profits, due to minimised downtimes and a safe installation, with low recurring costs. This allows him to achieve competitive advantages and he can apply his resources to investments, which add value.

The planner or designer of an installation

The planner or designer of an installation advises and consults with good arguments for the miniature circuit breaker – and makes an impact as a partner when recommending miniature circuit breakers. He secures further competitive advantages and follow-up commissions from satisfied customers. Furthermore, daily work is simplified in as much that the size of the safety switch always remains the same independent of power supply and voltage.

Trade

The uniform, compact size simplifies storage and decreases the otherwise necessary product range. The higher initial costs of the miniature circuit breaker also guarantee turnover. And this, when you consider that the same time is spent as in selling fuses.

New design for a fast current limiting and interrupting device

Henrik Breder: *Corporate reasearch*

Joachim Becker: *Product Manager - DIN Rail Products*

Current limiting and interrupting by a MCB

It is very important to interrupt an electric circuit when a short-circuit occurs. The main basic functional components of today's Miniature Circuit Breakers are a bimetal overload trip, an electromagnetic release for short-circuit trip, a switching mechanism with contacts and an arc extinguishing system. Picture 1 shows the basic components.

In this article we concentrate on the short-circuit tripping device. The electromagnetic short-circuit trip consists of a solenoid coil. In this coil there is a fixed iron core with movable plunger which is hold in position by a spring. In the iron core and the spring the hammer trip is

positioned. When the current exceeds a pre-determined value, the electromagnetic force generated by the coil attracts the plunger against the force of the spring.

During the fault the contacts of the MCB open due to the activation of the magnetic release that separates the contacts after a time delay due to the mechanical inertia. Depending on the rated current and the tripping characteristic the time delay is between 0.5 ms and 1 ms.

For this time the short-circuit current is only limited by the internal resistance of the MCB. When the arc moves into the arc extinguishing system the arc voltage exceeds the supply voltage and the current is limited.

- 01 Basic functional components of a MCB
- 02 Shows the new device
- 03 Short-circuit diagram

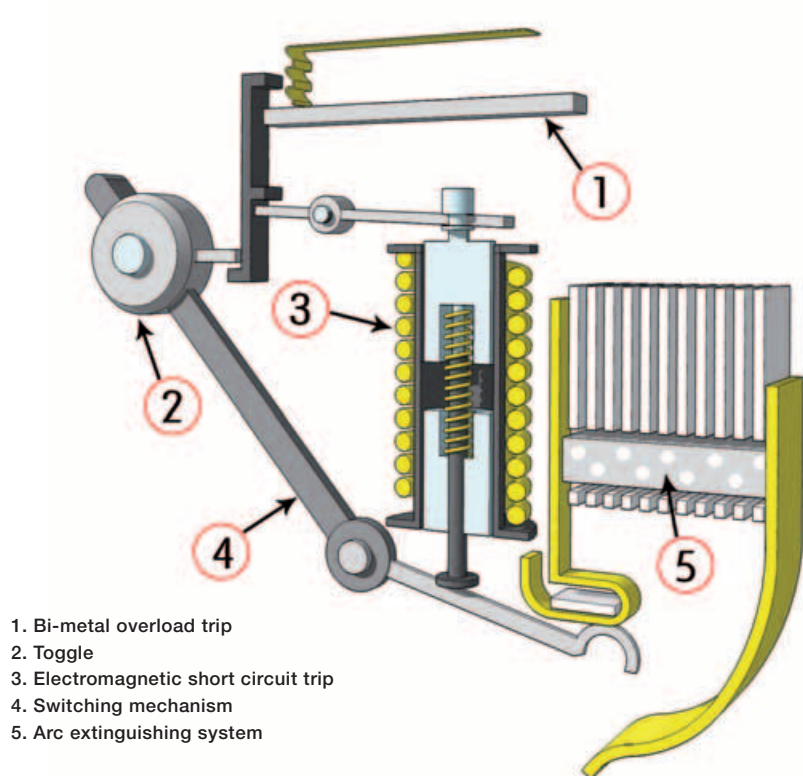

- 1. Bi-metal overload trip
- 2. Toggle
- 3. Electromagnetic short circuit trip
- 4. Switching mechanism
- 5. Arc extinguishing system

Special requirements

For special applications, e.g. DC systems with electronic loads, it is necessary to limit the short-circuit current even more than with a MCB. Many systems use large numbers of supplies in parallel where failure in one single supply unit can jeopardize the whole station unless the system is protected. During a short-circuit in one single supply the supply voltage in all parallel branches drops on a certain level. If this voltage drop is too high and rests for more than 10 ms the whole system will shut down due to the disturbance of the supply voltage. One solution today is to use damping resistors providing some current limitation and to ensure selectiv-

ity in order to keep the maximum voltage variation, i.e. sag during fault within specified values. A second solution is the use of hold-up capacitors with blocking diodes to keep the voltage level. All this solutions affect the reliability of the system and additional components must be installed. Additionally the damping resistor causes power loss and heat generation during normal conditions.

To eliminate these disadvantages the Corporate Research Center in Västerås, Sweden, developed a fast current limiting an interrupting device for the use in DC systems up to 60 V DC.

Basic principle of the new device:

A contact bridge providing a pair of moving contacts runs as an anchor through a thin (0.6 mm) air gap in an iron core. The air gap is pre-magnetized by means of a coil winding around the core. The core is made of laminated transformer steel to avoid eddy currents. The main current direction and the pre-magnetization field polarities have been selected in order to provide a common force pulling the contact towards the center of the magnetic iron core. The current limitation is mainly influenced by the speed. The laminated core increases the acceleration and consequently reduces the current magnitude.

- Short-circuit tripping unit with laminated iron core (1).
- The short-circuit current generates the magnetic field, the resulting Lorentz force acts directly on the contact bridge (2).

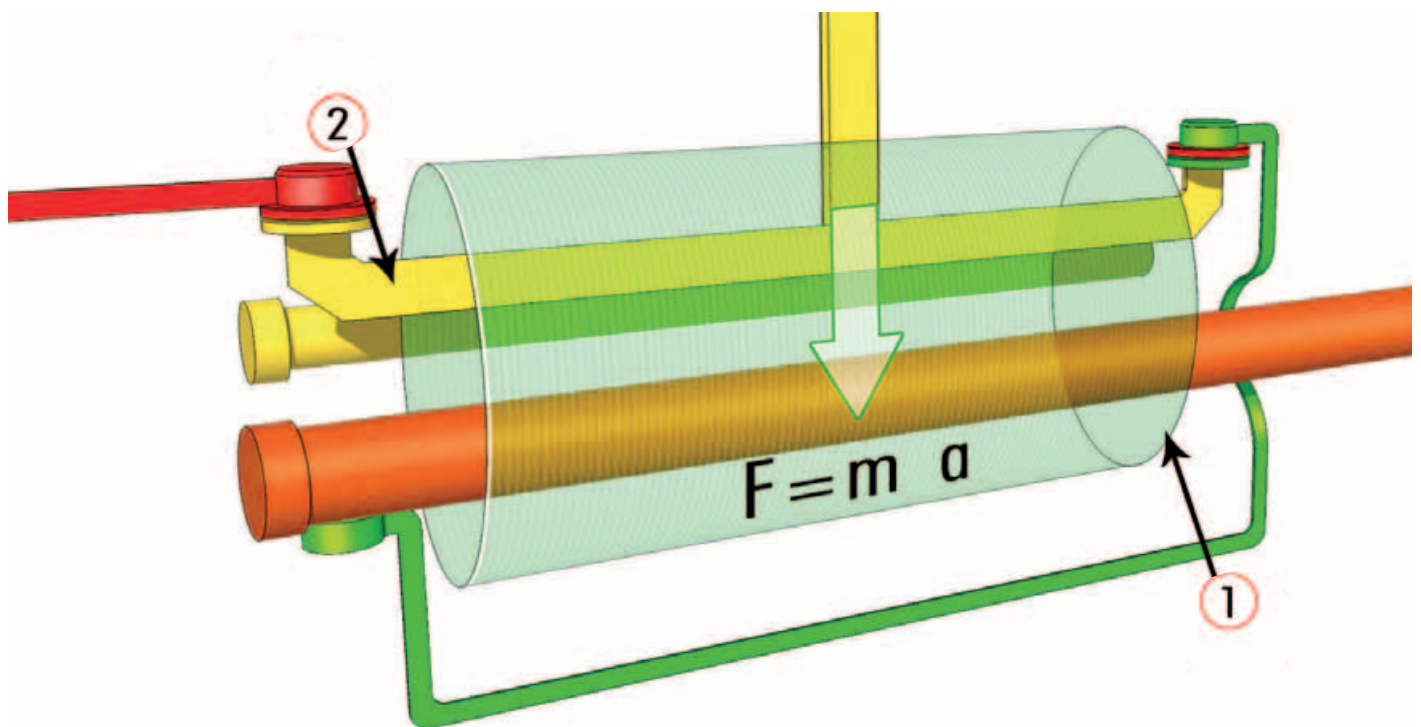

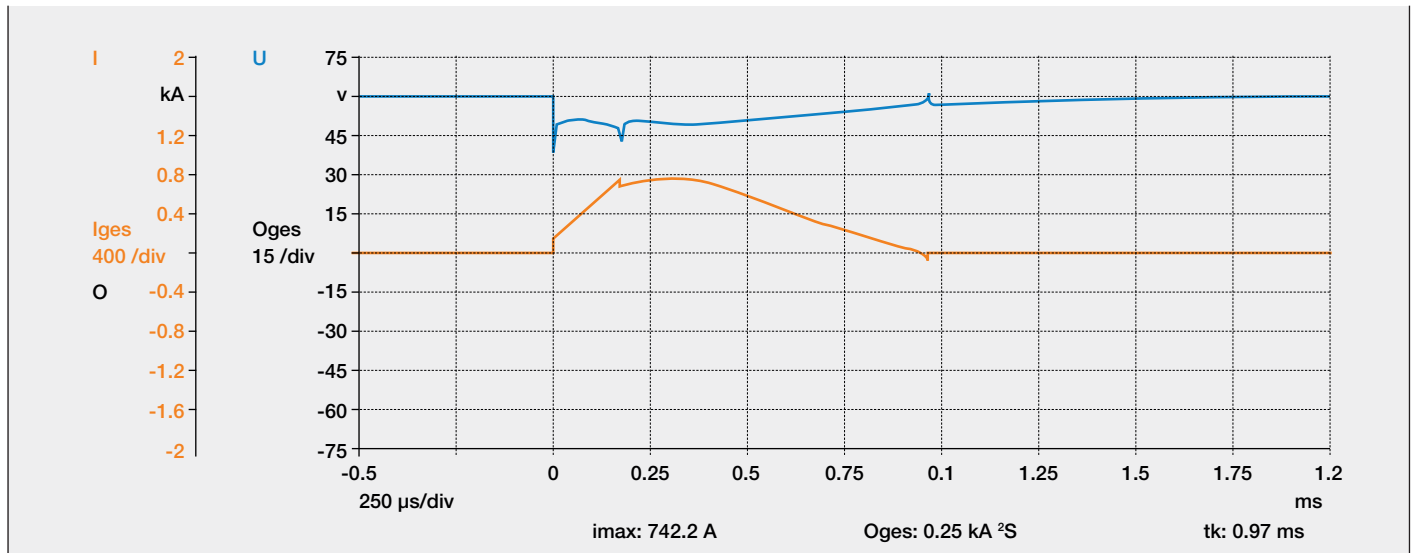

A prototype of the device was built and tested at ABB STOTZ-KONTAKT. Picture 3 shows a typical oszillogram of a short-circuit test.

The oszillogram shows a test with voltage supply with battery 60 V DC and a prospective short-circuit current of 2.2 kA DC.

Summary

The new design of a fast current limiting and interrupting device was presented. First prototypes were tested at ABB STOTZ-KONTAKT. The experiments show that a fast limitation and interruption of fast-rising currents in fault situations can be fulfilled by using an electromagnet lifting of the contacts based on energy from the main current.



Henrik Breder
Corporate research



Joachim Becker
Product Manager - DIN Rail Products

Customer feedback

Surge Protective Devices

OVR NE12 Series - Enclosed SPD

Mining and Aggregates

OVR NE12 Enclosed SPD

Electrical surges can be a real downer. A construction's stone quarry in Oklahoma found this out the hard way.

Upstream load switching by the utility was causing surges on the electrical network, having a direct impact on the power quality reaching the quarry. The surges were damaging the crusher, conveyor, motors and drives, causing downtime, loss of revenue and expense to replace the damaged equipment. The quarry manager estimates lost revenue and expenses in excess of \$100,000.

The quarry produces 1.2 million tons of construction aggregate per year, and uptime is the most critical element of the operation. Unplanned down-time creates operational and safety issues as customer trucks back up on site, haul trucks are required to load material from stockpiles and maintenance crews work to bring the operation back online.

A solution was needed to ensure no further damage and downtime would result from electrical surges. The area independent ABB sales rep, and the local distributor, providing the quarry with ABB products

such as softstarters, contactors and overloads. They suggested ABB's new surge protective device, the OVR NE12 enclosed SPD. The OVR NE12 was developed to compliment ABB's existing DIN rail line of surge protective devices. It is designed for installation at the service entrance, protecting the entire facility or operation from external surges.

The model selected was the OVRNE12320480DX, to work with the 480V Delta 3-phase network, provide 320kA protection per phase, and come equipped with a surge counter/diagnostic screen. Since the installation of the OVR NE12 unit in mid 2010, the unit surge counter has recorded seven surge events and the quarry has experienced no surge related issues.

The manager of the quarry is happy with the protection the OVR NE12 provides and recommends this type of device to others who require surge protection. "If this piece of equipment (OVR NE12 enclosed SPD) can keep us up and running, and help us produce more material in a given day, then it is successful and helps us reach our goals and be more productive."



Jeff Disbrow
Product Marketing -
Surge Protection/Ground Fault/MDRCs
Enclosures and DIN Rail Products



Lights on for EURO 2012

Daniela Donzelli: *Web & Technical Information - LP Division*

ABB took the field with its technology for lighting the stadia which hosted EURO 2012, the 14th UEFA European Football Championships which ran from the 8th of June and ended with the final on the 1st of July.

The system in the Lviv Arena in the Ukraine, managed with ABB technology, debuted during the Germany - Portugal match on the 9th June, lighting up the first big match of the tournament, won 1-0 by Germany.

In evening matches, it is essential that lighting conditions in the stadium are optimised both for the play and for the enjoyment and involvement of the fans.

ABB's control systems avoid the footballers and spectators being left in the dark. In particular, the centralised lighting controls and relative power consumption management software optimise the light level in the stadia on the basis of the natural light conditions.

Another system which allowed fans to enjoy the best lighting conditions was Donbass Arena, in Donetsk. Here, France played England on the 11th of June, drawing the first match scheduled for this 60,000-capacity ground 1-1.

In this venue, 100 DALI gateways supplied by ABB connect the lighting system to the ABB i-bus KNX system, from the changing rooms to the VIP stand; the KNX-standard management system regulates the system's light levels and coloured lighting displays at the right times, ensuring an unforgettable experience for the spectators.

Many English and French fans had been able to appreciate the performance of the ABB i-bus KNX Building Automation system even before kick-off.



ABB Building Automation systems are also installed in Donetsk airport, which many fans travelled through on the way to see their teams play.

Ukraine was one of the host countries of EURO 2012, and debuted as an independent team with the knowledge that the lights being lit on their participation was also thanks to ABB technology.

ABB Wizard: the right choice which is always accessible

Francesca Sassi: Product Marketing Manager - DIN Rail Products

A collection of Apps which you can use, where and when you like.

In recent years the web has become a constant presence in our lives: it is a "media" which is on the up, it has increasingly become an important part of our daily routine.

In recent times we have witnessed a "revolution", which has opened new possibilities and which has furthermore helped the web to expand. The net has become larger, embracing an increasing number of users: this process has been aided by significant technological progress which has allowed for a greater degree of mobile accessibility to the web and has led to the development of new devices, such as smartphones and tablets and the instruments which can harness their potential, such as Apps for example.

In order to understand the size of the phenomenon, just think that in 2011 the number of mobile devices sold worldwide (smartphones and tablets) has overtaken the number of PCs sold: 470 million units, compared to 350 million units. It is also

interesting to note that, while Microsoft, is the undisputed leader in the PC sector, the mobile market is divided between two competitors, iOS from Apple and Android from Google.

The number of mobile phone subscriptions reached almost 6,000 million at the end of 2011, representing a penetration rate of 86.7 percent worldwide and 78.8 percent in developing countries, according to estimates published by the International Telecommunication Union (ITU).

The mobile Internet via broadband reached 1,190 million subscribers in over 160 countries at the end of 2011 and it is estimated that in developing nations, 8.5 percent of the population has access to that service, which is a considerable increase compared with 5.3 percent a year earlier.

The data traffic doubles every year and in 2015 it will be 95% of all telephone traffic. For the first time, in 2012, the voice traffic will fall below 50% of the total.

Taking the above into consideration and the will to provide our customers with innovative and accessible solutions, we

initiated the ABB Wizard project which is dedicated to the creation of Apps. Our aim is to make product information directly accessible by means of mobile devices.

ABB Wizard Apps are available for the two main platforms (Apple and Android), which thanks to a few simple steps, allow users to identify the most suitable low-voltage products for a determined application.

The Abb Wizard project allows our customers to access information relating to their work needs, wherever and whenever, by selecting the necessary product code, which supplies all the relevant technical characteristics and links to reference documentation.

Take a look at the section on the ABB Wizard App!

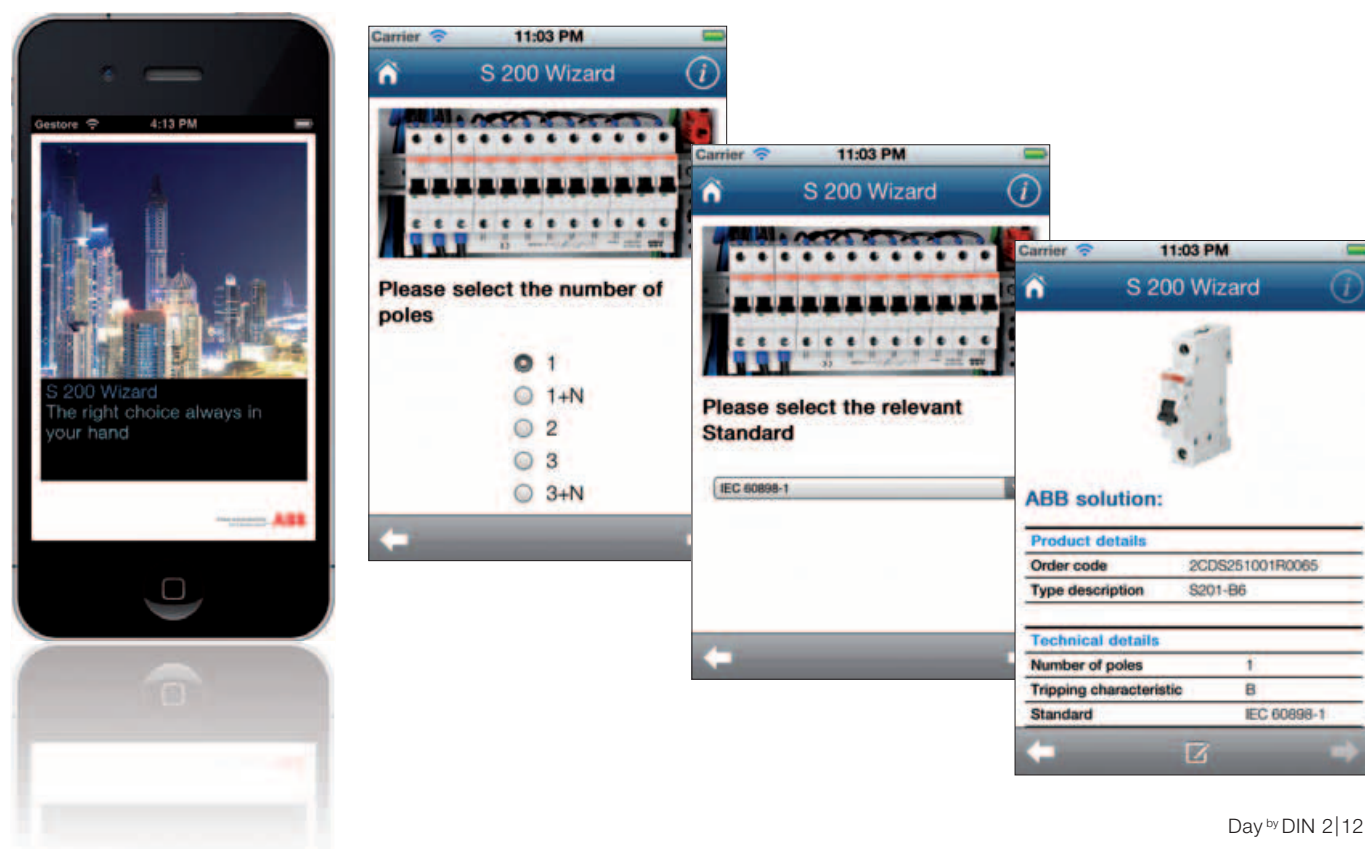

From electrician to marketer: pump up your business!

Federico Mai: *Marketing Communication Account - LP Division*

Products, technical specifications, performances, functions and examples of applications are all essential knowledge for electrical installers. However, it is equally clear that in an ever-more competitive market such as today's, it is more important than ever to acquire skills in non-technical fields in order to differentiate yourself from competitors and thus increase turnover.

For this reason in this section you will find a small list of tips that we think will help you to better understand marketing and communications theory and practice and apply them to your work. These things often make the difference when approaching a customer (as services, products and prices offered are often very similar), stimulating the creation of new ideas and solutions or simply helping get past the questions "Where do we start?" or "How do we do this?".

AIDA, or the four pillars of an effective message

AIDA is a theoretical operational model for marketing and advertising. It is an acronym which summarises the four fundamental points which a message must deal with in order to be effective: Attention (Awareness), Interest, Desire and Action.

Description of the model components

1. **Attention** (Awareness). The message must, first of all, capture the target attention: every day, a typical person is exposed to a number of adverts estimated to be between 300 and 3,000, depending on the source. Only a small fraction of these receives any attention and fewer of them will manage to effectively influence the target. As such, it is clear that the message must not just be good, but exceptional.
2. **Interest**. The message must pique the target interest: it is not enough to grab the attention, they must be made to read, look and look again. The message must capture the target selective attention.
3. **Desire**. The message must spark the process of creating desire in the target. When the target identifies himself (or identifies its reference model) with the situation offered, a sort of projection of its ego and personality onto the message itself occurs.
4. **Action**. The message must spur the target to act, to do something. And usually, but not always, this "something" is making a purchase.

Comments

AIDA was presented for the first time in 1898, becoming popular in the sixties. Historically, it was one of the first "models" developed for implementing an advertising campaign. Today, AIDA is considered a model which is relatively simple, yet still effective, above all for encouraging product purchase (see the ad/buy the product). In particular, the last point (Action) assumes a power which advertising does not have, inasmuch as "effective advertising" means it is able to create a positive attitude, benevolence, kindness with regard to a product or a brand. This means it is capable of evoking desire for it and the conviction that the advertised product represents a valid and desirable solution, or rather the best possible solution. All of this in order to stimulate an inclination towards purchase, or even an intention to purchase, but not the purchase directly. Anyway, the AIDA model remains a valid reference for creating an effective communication campaign. This is even more the case when the aim is not to encourage the target to make a purchase, but to perform some other action, such as filling in a coupon, requesting more information, clicking a link in a newsletter etc.

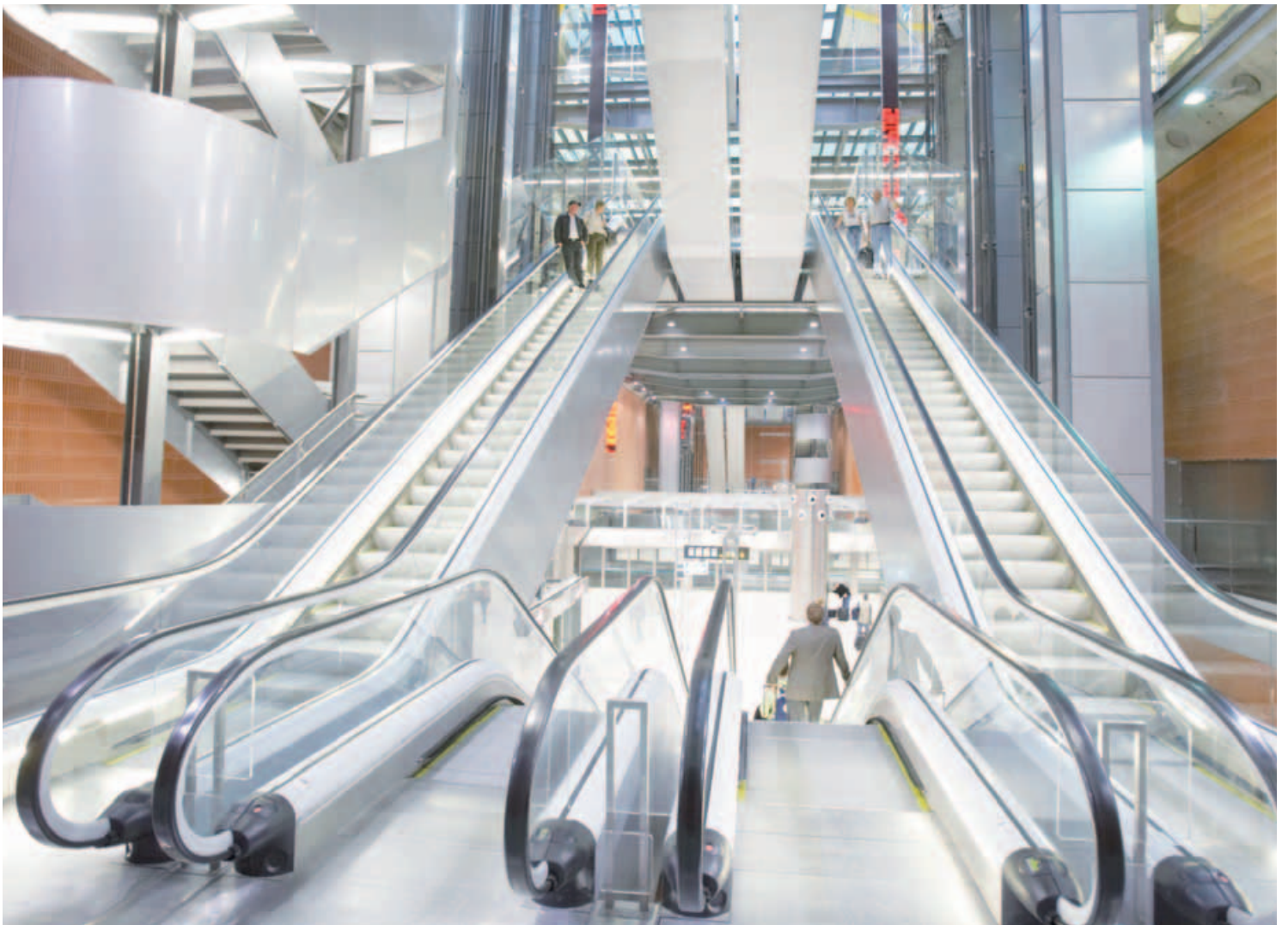

E 90 range. Designed by ABB for the most demanding customers.



Suitability for disconnection and switching, effective heat dissipation and certified compliance with several international standards are mandatory requirements to meet the needs of the most demanding customers. ABB has dedicated its designers' passion, competence and creativity to the development of E 90 new range of disconnectors and fuseholders. The result is the first AC-22B fuse-switch disconnector, IMQ and UR certified up to 32 A and 690 V.

www.abb.com/lowvoltage

How to choose an optimized External Lightning Protection (ELP)

OPR external lightning protection:
The easy way to avoid the sky falling on your heads!

Bertrard Berger: Product Marketing Manager - DIN Rail Products



An ELP what for?

Lightning currents are causing fires, explosions or dangerous dysfunctions. To avoid direct strikes on the structure, the principle is to catch the lightning strike on a rod and evacuate the energy to the ground with specific down conductors and ground systems.

An External Lightning Protection can be done with various technologies, that differ from country to country according to local habits, or depending on the shape of the building itself. Some technologies are more used for small constructions when others are more adapted to bigger ones or open areas. An External Lightning Protection is always made after a lightning risk analysis of the structure. The ELP installation as well as its efficiency, both will vary depending upon this level of protection. This level of risks varies from 1 (highest LPL) to 4 (lowest LPL).

A good ELP is always the right balance between a reasonable cost for the protection and the probability that we will have to deal one day with a lightning event, this is the reason why the risk assessment is necessary in order to adapt the right protection to each site.

The IEC 62305-1 Standard considers lightning event going roughly from 3kA to 200kA. Both tables 3 & 4 are extracted from this Standard and summarize Max & Min that Standard is taking into account.

Since what has been called by scientist the "electro geometrical model", these lightning currents are modelised by spheres, whose radiuses are proportional to their currents. See table 4 extracted from IEC 62305-1 Standard.

In External Lightning Protection we are more focused on small currents as these are more difficult to catch than bigger ones and this for a simple reason: it is easier to catch a big ball than a small one!

Table 1 - Maximum values of lightning parameters according tl LPL

First positive impulse			LPL			
Current parameters	Symbol	Unit	I	II	III	IV
Peak current	<i>I</i>	kA	200	150	100	

Table 2 - Minimum values of lightning parameters and related rolling sphere radius corresponding tl LPL

Interception criteria			LPL			
	Symbol	Unit	I	II	III	IV
Minimum peak current	<i>I</i>	kA	3	5	10	16
Rolling sphere radius	<i>r</i>	m	20	30	45	60

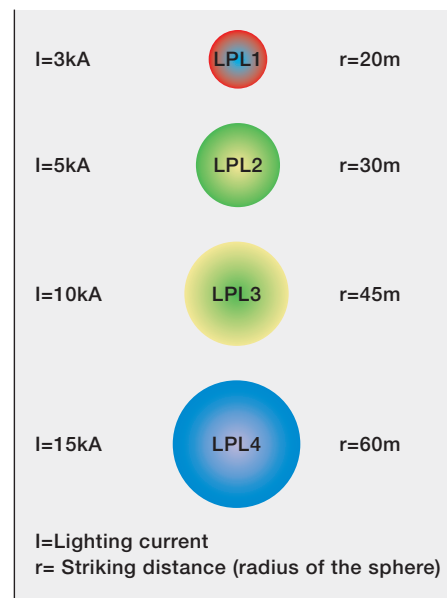

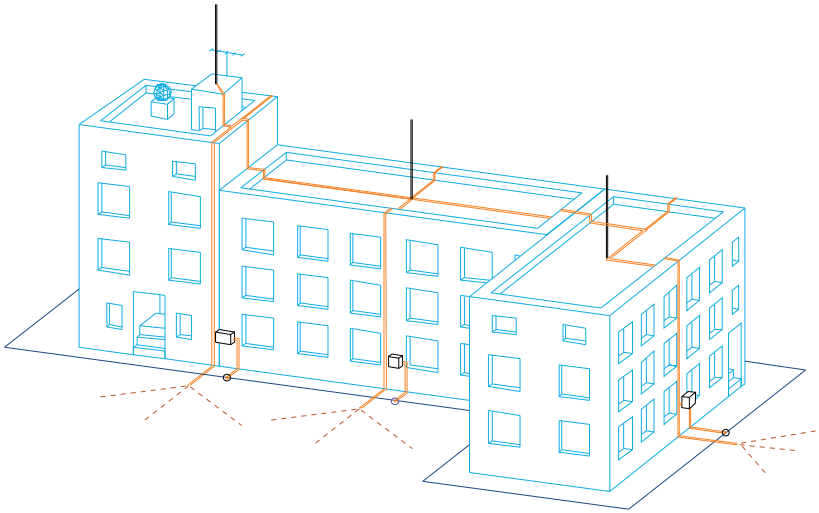

Presentation of available ELP

Simple lightning rod air terminals

By producing upwards from the building, they are likely to trigger the release of ascending streamers and thus be selected as impact points by lightning strokes occurring within the vicinity of the structure.

This type of protection is especially recommended for radio stations and antenna masts when the required area of protection is relatively small.

A simple lightning rod conductor installation is made of:

- a rod or various rods with their extension mast

- two down conductors per rod
- a test coupling on each conductor
- a protecting flat to protect the down conductor on the last two meters above ground level.
- An equipotential bonding between each lightning earthing systems and the general electrical earthing of the installation.

The protection area is given by angle of protection depending on the lightning protection level (LPL) see below abacus extracted from IEC 62 305-3:

Knowing the angle of protection and the size of the rolling sphere radius the following table gives the radius of protection in regard to height of the rod:

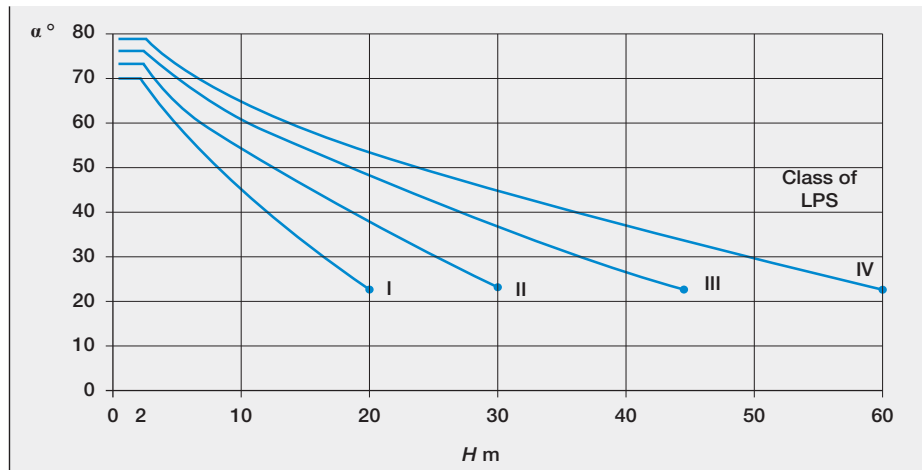

Radius of protection Rp (m)				
H m	Level of protection H			
	I	II	III	IV
2	5	6	9	11
4	8	10	12	15
6	10	12	15	20
8	10	13	17	21
10	10	14	17	22
20	10	15	21	29

Early streamer emission air terminals (ESEAT)

The radius of protection for ESEAT comes from below formulas given in the NFC 17 102 Standard hereafter.

The main advantage of this technology is that it can cover very large areas (up to 107m of radius in LPL4) and it can also protect open areas such as amusement parks, stadium or tennis courts. Also not negligible ESEAT installations are minimum 4 times cheaper than a passive solution (simple rod or meshed cage).

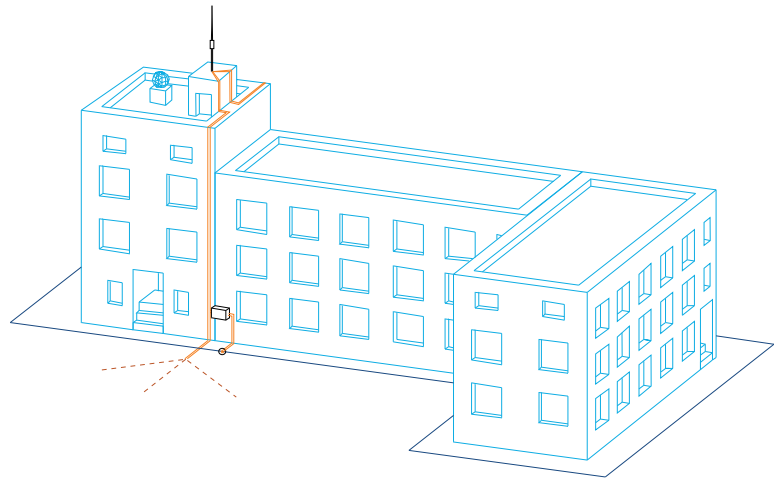

Operating principle

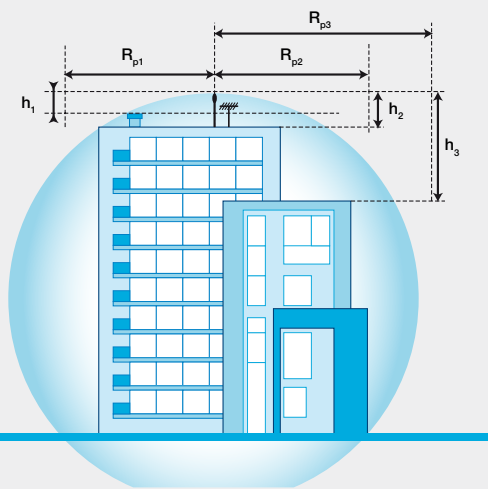
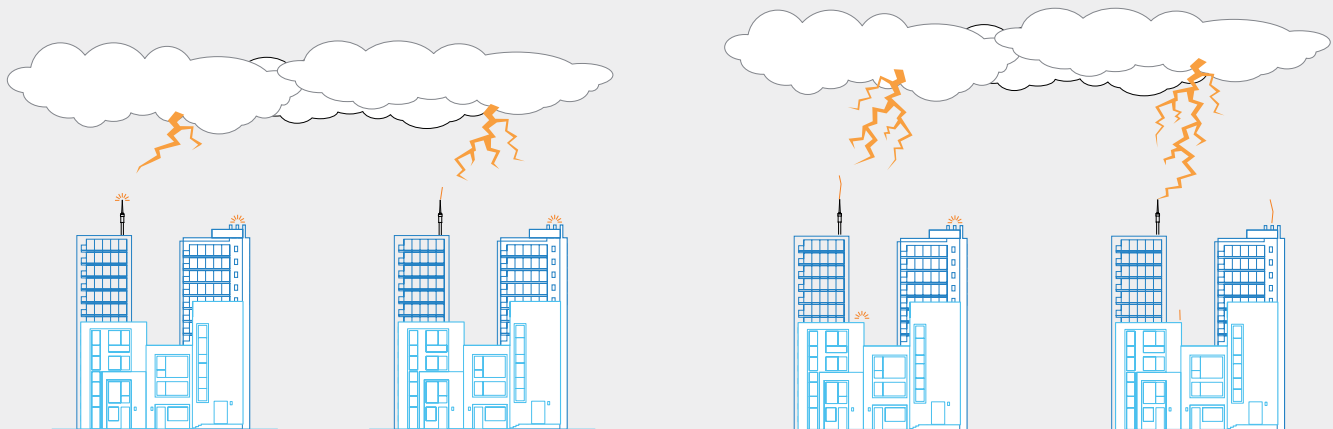

Rp (h) : Protection radius at a given height (h)
 $R_p(h) = \sqrt{2rh - h^2 + \Delta(2r + \Delta)}$ (for $h \geq 5$ m)

For $2 \text{ m} \leq h < 5 \text{ m}$, refer to the table above

h : Height of the OPR tip above the surface (s) to be protected

r (m) : Standardized striking distance (depend on LPL level)

Δ (m) : $10^6 \Delta T$ (OPR efficiency)

OPR radius of protection

Protection level	I (r = 20m)		II (r = 30m)		III (r = 45m)		IV (r = 60m)	
OPR	OPR 30	OPR 60	OPR 30	OPR 60	OPR 30	OPR 60	OPR 30	OPR 60
h (m)	Radius of protection Rp (m)							
2	19	31	22	35	25	39	28	43
3	29	47	33	52	38	58	43	64
4	38	63	44	69	51	78	57	85
5	48	79	55	86	63	97	71	107
6	48	79	55	87	64	97	72	107
8	49	79	56	87	65	98	73	108
10	49	79	57	88	66	99	75	109
15	50	80	58	89	69	101	78	111
20	50	80	59	89	71	102	81	113
45	43	76	58	89	75	105	89	119
50	40	74	57	88	75	105	89	120
55	36	72	55	86	74	105	90	120
60	30	69	52	85	73	104	90	120

Meshed cages

This principle consists in dividing the lightning current by a network of roof conductors and down conductors to earthing system. The large amount of down conductors insures to have low disturbance by induction, this solution is preferred when the building contains very sensitive equipment regarding to electromagnetic disturbances such as data centres.

A mesh cage installation is composed by:

- strikes point: to capture the atmospheric discharges
- roof conductors and down conductors
- earthing systems
- an equipotential bonding between each earthing system and the general earthing circuit of the structure.

The size of the mesh is also depending on every External Lightning Protection installations of the LPL: see below table extracted from IEC 62 305-3

The main drawback of this solution is the cost as a huge amount of copper is needed, which price is expensive and constantly increasing.

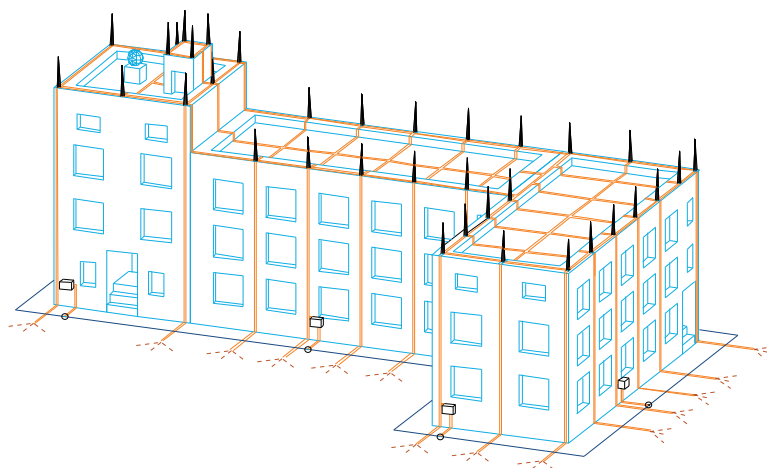

Class of LPS	Protection method	
	Rolling sphere radius <i>r</i>	Mesh size <i>W</i>
	m	m
I	20	5 x 5
II	30	10 x 10
III	45	15 x 15
IV	60	20 x 20

Stretch wires

This system is composed of one or several wires stretched above the installation that needs protection. The protected area is determined by applying the electro geometrical model.

Wires must be earthed at each end. A stretched wire installation requires a through preliminary study to consider issues such as mechanical strengths, the type of installation and insulation distances. This technology is used to protect ammunition depots and, as a general rule, when it is not possible to fix the ELP on the structure itself.

Whatever the ELP chosen, in case of installation of an external protection it is always necessary to protect the internal electrical networks using as a minimum a type 1 SPD in the MDB. Type 1 surge protective devices are tested with a 10/350µs wave form, representing a direct lightning impact on a structure.

In conclusion a good Lightning Protection starts always by the risk assessment of the building that we want to protect, then if necessary the installation of an ELP to protect the building against direct strikes in combination with a coordination of type 1 and 2 SPD to protect the internal electrical networks.

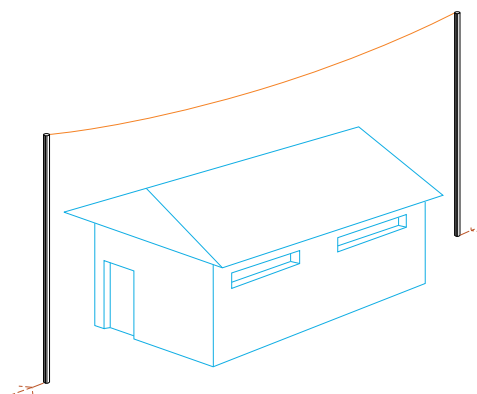

Bertrand Berges
Product Marketing Manager
DIN Rail Products

TwinLine – ABB's innovative Sub-Distribution system

Henk Halmingh: *Product Marketing Manager - Enclosures*



With its TwinLine system ABB offers a modern way of assembling sub-distribution. The fully comprehensive product range of wall-mounting and floor-standing cabinets is available in three depths with a high degree of protection IP55.

Cabinet depth's of TwinLine are:

- 225 mm depth = TwinLine-G
- 275 mm depth = TwinLine-L
- 350 mm depth = TwinLine-W

All TwinLine cabinets meet the new requirements defined according IEC 61439 and DIN EN 61439 Part 1 and Part 2. TwinLine can be obtained according protection classes I and II.

Intelligent adaptations in terms of innovative flange technology and uniform fastening for all internal configurations. Due to ease of cabinet connection and the modular plinth it guarantees ease of installation.

Innovative cable entry

The actual usable cable entry area is 80% larger than normally available in this kind of enclosures and is one of largest cable entries available on the market.

All flanges achieve the IP55 degree of protection and the mounting of the flanges can be done without any extra or special tools thanks to the "push and lock" technology.

Uniform fastening for all internal configurations

TwinLine offers a new type of internal frame holder. Today's available ABB Striebel & John types of internal frames can be used within the same structure and can be adjusted in depth's of 12.5 mm. This uniform internal frame holder reduces the number of assembly components required.

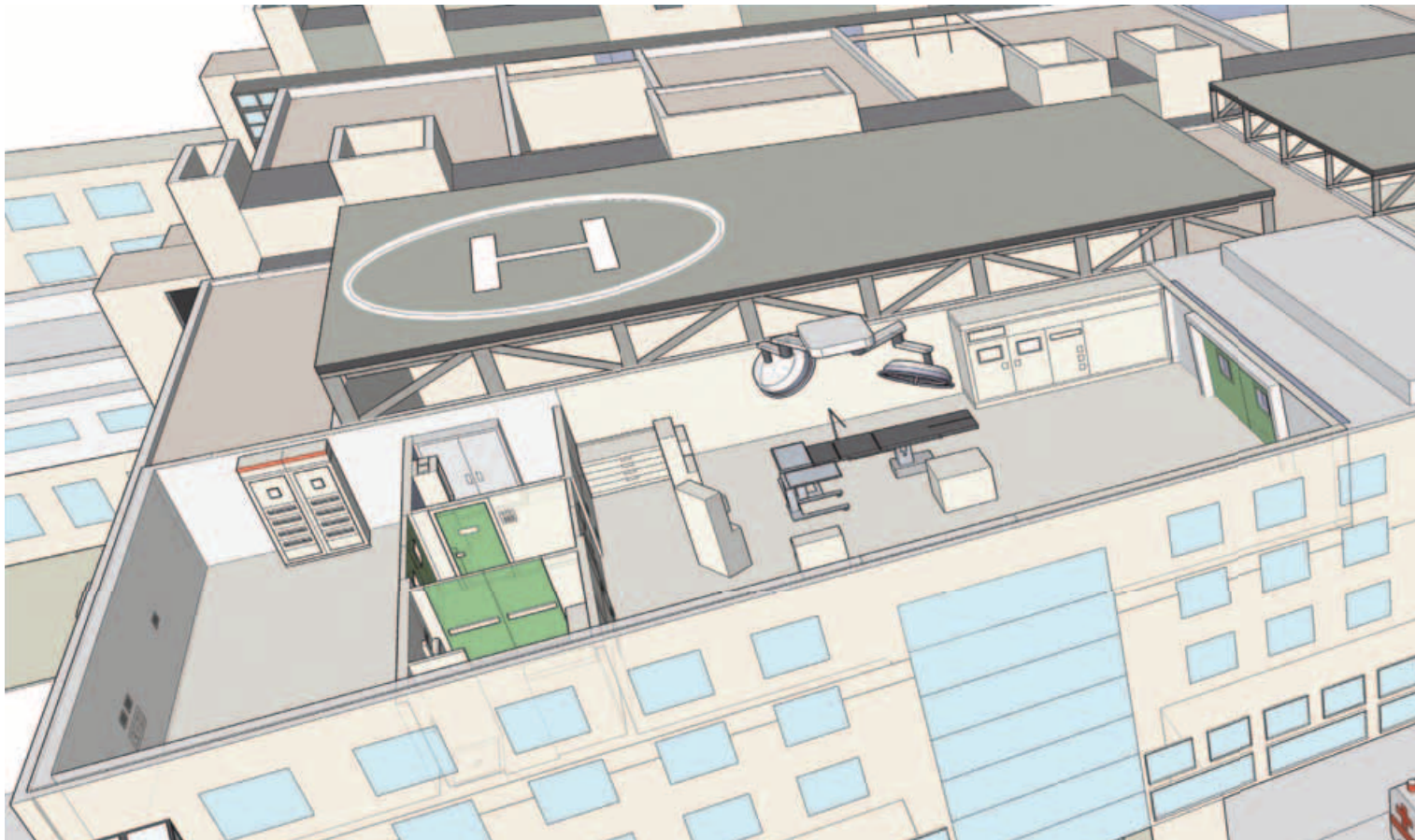

Even a mix of different types of mounting frames and mounting plates can be used in one single wall-mounting cabinet with an end result of one homogeneous installation level. TwinLine makes simple and flexible installation in a snap and helps customers to obtain a high degree of possible configurations. These configurations can be done with for instance the standard available functional modules from ABB Striebel & John, called CombiLine-M.

Optimal accessibility and ease of installation

With its 180-degree door opening TwinLine offers unrestricted access during operation, expansion, maintenance and functional monitoring. The door locking system guarantees excellent flexibility, since the door hinges can be switched from right to left and visa versa.

Simple connection in series of all cabinets

All TwinLine cabinets can be connected side by side in both, horizontally and vertically directions. The large flange openings and knockouts ensure that main busbar systems can be installed conveniently between the different cabinets with the same depth.

Time-saving plinth installation and safe transport

Construction of the new plinth does guarantee a secure transport in the workshop and on site. The plinth contains knockouts and has the possibility to install wiring ducts for cable support. The standard heights of 50 mm and 100 mm can be stacked and combined in order to fulfil installation needs.



Henk Halmingh
Product Marketing Manager
Enclosures

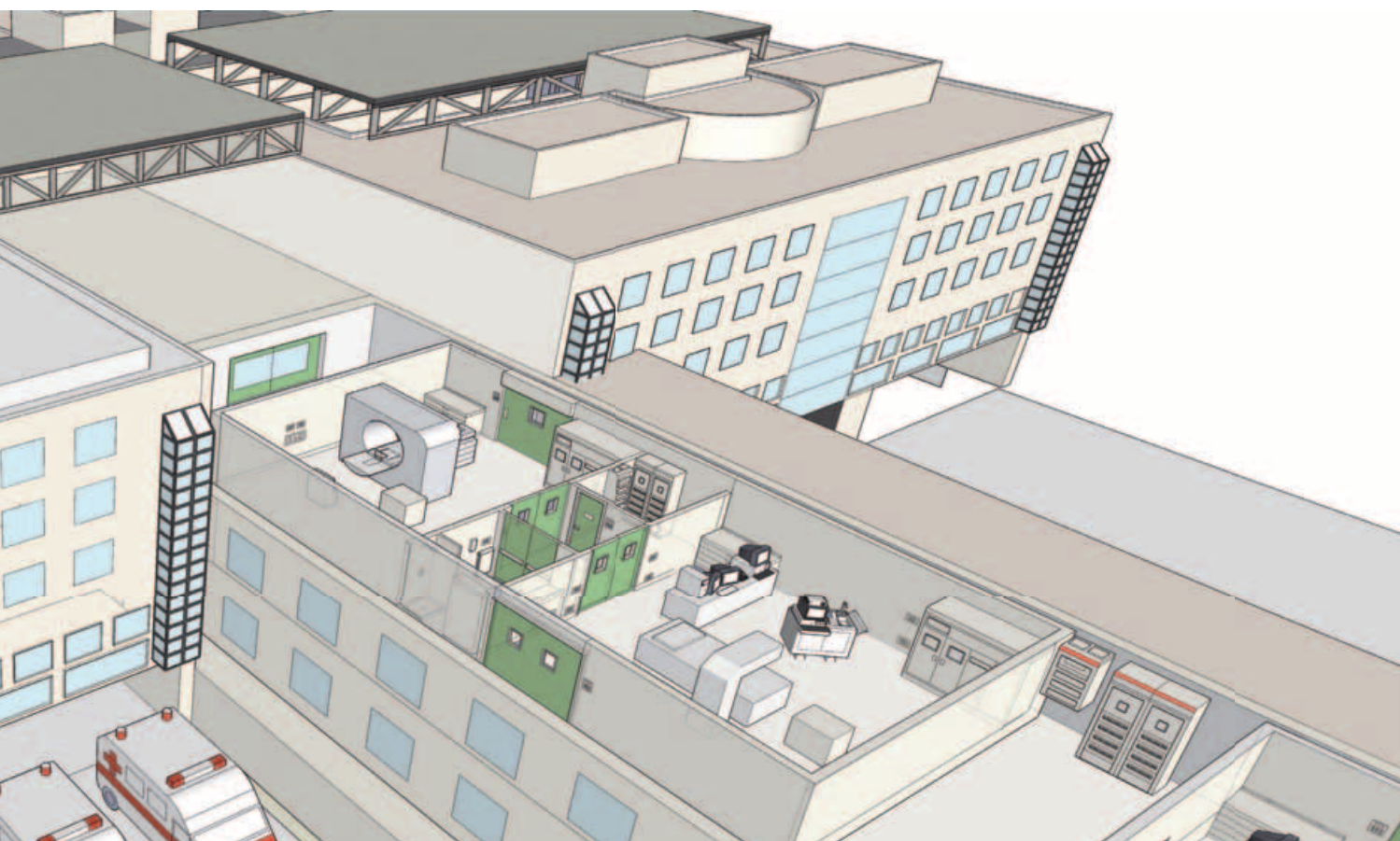

Quiz

Tests for those who are really skilled

Do you want to test your competence and relative knowledge on low voltage products? On this page, from time to time, questions related to application of apparatus will be put forward, starting from an easier subject and moving on to a more difficult one, to which to reply.

1- Easy

If I read the following values on a multimeter display, such as a DMTME, installed in a single-phase system for direct insertion via a 50/5 A voltage transformer:

Power P = 1 kW
Energy E = 1 kWh

are they coherent consumption values, given a nominal current of $I_n = 50$ A, $I_{sec} = 5$ A, voltage $V = 230$ V?

Answer
No, because, in the calculation, as a transformation ratio the default value of the instrument was used equal to 1

$$P_{incorrect} = V \cdot I_{sec} \cdot k_{CT} = 230 \times 5 \times 1 = 1,15 \text{ kW}$$

It is necessary to consider, instead, $k_{TA} = I_n / I_{sec} = 10$ and you get:

$$P_{correct} = V \cdot I_{sec} \cdot k_{CT} = 230 \times 5 \times 10 = 11,5 \text{ kW}$$

2- Medium

If I read the following values on a multimeter display, such as a DMTME, installed in a single-phase system for direct insertion via a 50/5 A voltage transformer:

Power P = 57.5 kW
Energy E = 57.5 kWh

are they coherent consumption values, given a nominal current of $I_n = 50$ A, $I_{sec} = 5$ A, voltage $V = 230$ V?

Answer
A was used, giving

$$P_{incorrect} = V \cdot I_{sec} \cdot k_{CT} = 230 \times 5 \times 50 = 57,5 \text{ kW}$$

The right value to use is, instead, $k_{CT} = I_n / I_{sec} = 10$:

$$P_{correct} = V \cdot I_{sec} \cdot k_{CT} = 230 \times 5 \times 10 = 11,5 \text{ kW}$$

3 - Difficult

Is it possible to read on the display of a DMTME multimeter the values $PF = 0.7$ and $\cos \varphi = 0.9$ for the same appliance?

If so, why?

Answer
Yes, because we are in a non-sinusoidal regime, therefore it is correct to find different PF and $\cos \varphi$ values. If we were in a sinusoidal regime we would have to have equal values of the two parameters.



Taking sub-metering to the next level?

Absolutely.



ABB's MID-approved EQ meters offer the same quality as revenue meters, approved meters and verified meters. EQ meters are certified and have verified meter accuracy, which is a critical factor in establishing fairness in cost allocation and distribution among tenants. Many EQ meters are also delivered directly from our factory with first time verification. ABB's EQ meters are high-performance, modular DIN rail-mounted electricity meters that are safe, easy to install and can be integrated with existing and future electrical installations. EQ meters are designed to fulfill any type of sub-metering requirement. www.abb.com/lowvoltage

Power and productivity
for a better world™



Connect the boxes

Train your brain

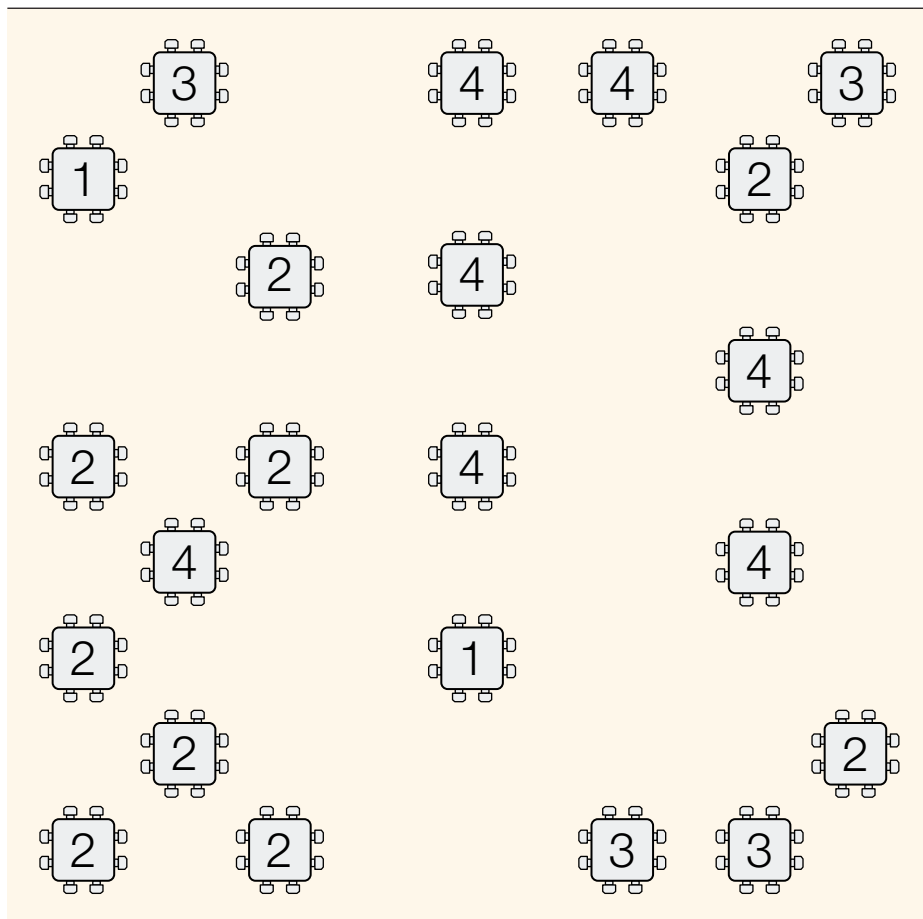

Task

You must complete an electrical system by connecting junction boxes with cable conduits.

An electrician has already installed all the junction boxes on the wall and laid down the required connections, but then he left the job unfinished without explanation.

Your task is therefore to connect all of the boxes indicated.

Instructions

- Each box must be connected to the others and the number of connections must correspond to that indicated on the box.
- Two different boxes can be connected with each other, but without exceeding two connections.
- Connections can be made either horizontally or vertically. Cross-connections are not allowed.
- There is only one correct solution and can be found purely by logical reasoning. No specific technical skills are required.

Take it easy

RECHARGE ↓

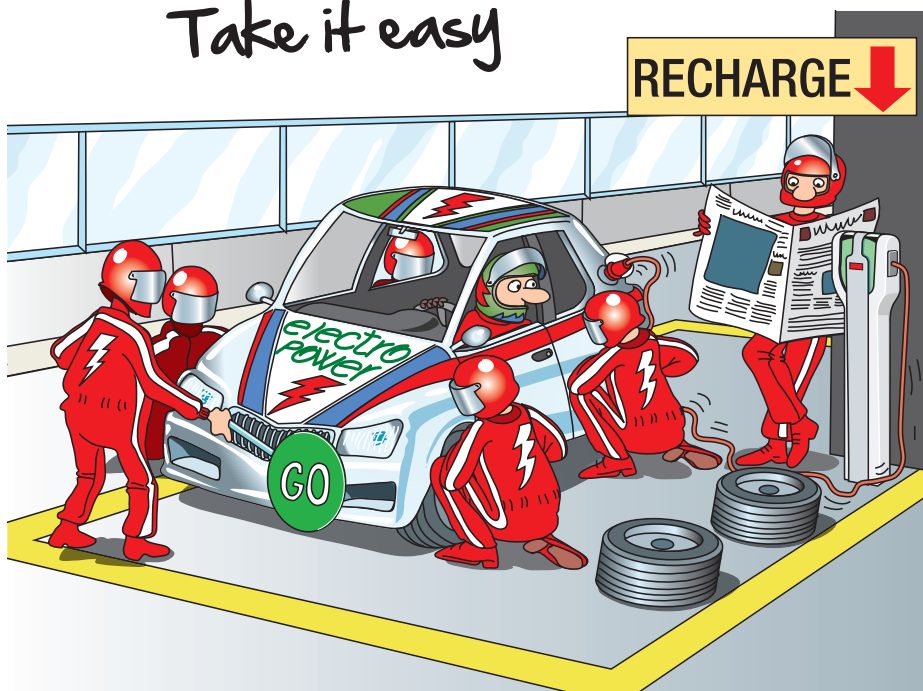

The solutions to Connect the boxes

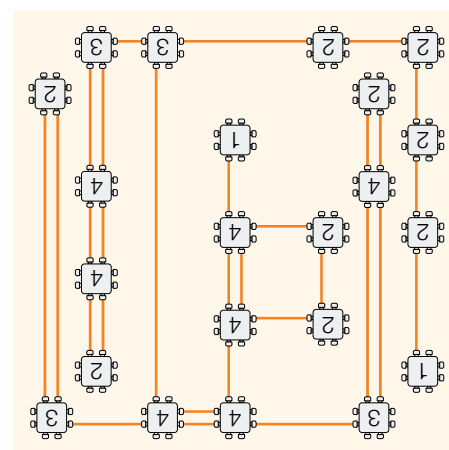



E210. Set new standards in your electrical distribution board.



ABB expands E210 range with new 2 and 3 LED indicator lights. E210 allows users to save valuable space in distribution boards thanks to narrow 9 mm width. E210 range is made for consumer units, large scale switchgear, commercial buildings and industrial control systems. The new 2 and 3 LED indicator lights are ideal in alarm and status indication of loads and switches and voltage presence. The ABB range encompasses on-off, change over, group and control switches, as well as pushbuttons with and without LEDs and a variety of indicator lights. E210 meets the most important related standards EN 60669-1, EN 60669-2-4, EN 62094-1 and UL 508. www.abb.com/lowvoltage



D Line 365 yearly digital time switches.
Infinite possibilities. All in perfect time.



D Line yearly digital time switches, thanks to over 800 memory locations and the ability to control up to 8 independent contacts, allow management of equipment requiring differently timed commands while using a single time reference device. They represent the ideal solution for meeting requirements for automation solutions, both in residential and service sector environments. Running cutting-edge software, D Line 365 provides on/off, astronomical, impulsive, cyclical, random and holiday functions as well, combining efficiency and flexibility thanks also to their ease of programming and PowerLine communications protocol, which allows automation of any electrical outlet without having to make modifications to the supply system. www.abb.com/lowvoltage



OVR PV. Excellent performances in maximum safety. Always.



Born from the experience of ABB, the first to launch them on a market which continues to choose them, OVR PV photovoltaic SPD ensure absolute protection in the photovoltaic systems. OVR PV SPDs are equipped with a patented thermal disconnecter, with d.c. short circuit interruption performances, specifically designed in order to prevent the risks of overheating and fires in photovoltaic systems up to 1000 V. Thanks to this innovative technology, OVR PV SPDs are self-protected from the end of life short circuit up to 100 d.c without the necessity of back up protection. This performance is guaranteed by the conformity to the UTE C61-740-51 guide.

www.abb.com/lowvoltage





OVR range surge protective devices
Make your choice faster than lightning!

OVR range surge protective devices

Make your choice faster than lightning!

System Type	System		SPD		Backup protection - MCBs or fuses		
	Type	Poles	Code	Type	Size	Code	Type
 1 and 2	If there is a lightning rod, in a general switchboard or if supply is aerial and delicate components are contained therein						
	TT, TN-S	3P+N	3 x 2CTB815101R0300 + 1 x 2CTB815101R0500	3 x OVR T1+2 25 255 TS + 1 x OVR T1 100 N	3 x 125A gG	2CSM377710R1801	E 933N/125
		1P+N	1 x 2CTB815101R0300 + 1 x 2CTB815101R0400	1 x OVR T1+2 25 255 TS + 1 x OVR T1 50 N	1 x 125A gG	2CSM375710R1801	E 931N/125
TN-C	3P	3 x 2CTB815101R0300	3 x OVR T1+2 25 255 TS	3 x 125A gG	2CSM373710R1801	E 933/125	

 1	If there is a lightning rod in a general switchboard or when electricity supply is via an aerial line						
	TT, TN-S	3P+N	2CTB815101R1600	OVR T1 3N 25 255	3 x 125A gG	2CSM377710R1801	E 933N/125
		1P+N	2CTB815101R1500	OVR T1 1N 25 255	1 x 125A gG	2CSM375710R1801	E 931N/125
TN-C	3P	2CTB815101R1300	OVR T1 3L 25 255	3 x 125A gG	2CSM373710R1801	E 933/125	

 2	In all switchboards, to protect terminal equipment from the electro-magnetic impulse of the lightning						
	TT, TN-S	3P+N	2CTB803953R0800	OVR T2 3N 40 275s P	3P+N C25A	2CDS254001R0254 ¹	S 204 - C25
		1P+N	2CTB803952R0800	OVR T2 1N 40 275s P	1P+N C25A	2CDS251103R0254 ¹	S 201 Na - C25
TN-C	3P	2CTB803853R2200	OVR T2 3L 40 275s P	3P C25A	2CDS253001R0254 ¹	S 203 - C25	

¹ 6 kA automatic switch. For other models see the ABB System pro M compact® catalogue.

Class	Photovoltaic, DC side		SPD		Safety - Only if ICC > 100A		
	Maximum Uoc voltage for string boxes	Remote contact	Code	Type	Size	Code	Type
 2	In string boxes for protection from surges on the DC side						
	670 V DC	-	2CTB803953R5300	OVR PV 40 600 P	2 x 10A gPV	2CSM204703R1801	E 92/32 PV
	670 V DC	YES	2CTB803953R5400	OVR PV 40 600 P TS			
	1000 V DC	-	2CTB803953R6400	OVR PV 40 1000 P			
1000 V DC	YES	2CTB803953R6500	OVR PV 40 1000 P TS				

