

# Low Voltage General Purpose Motors

Steel motor section



# Making you more competitive

ABB's General purpose motor is designed for use in general industry, meeting the demands of standard applications for OEM's. Motors are readily available from central stock locations and distributors around the world. The motors have high build quality, are available with all the features needed by the OEM market and can be modified to meet most specifications.



*ABB ([www.abb.com](http://www.abb.com)) is a leader in power and automation technologies that enable utility and industry customers to improve performance while lowering environmental impacts. The ABB Group of companies operates in around 100 countries and employs around 103,000 people.*

# Low Voltage General Purpose Motors

Sizes 56 to 400, from 0.055 to 630 kW

	Contents	Page	
<b>1</b>	<b>General information</b>	<b>4</b>	<b>1</b>
<b>2</b>	<b>Aluminum motors</b>	<b>11</b>	<b>2</b>
<b>3</b>	<b>Steel motors</b>	<b>81</b>	<b>3</b>
<b>4</b>	<b>Cast iron motors</b>	<b>113</b>	<b>4</b>
<b>5</b>	<b>Open drip proof motors</b>	<b>147</b>	<b>5</b>
<b>6</b>	<b>Global motors</b>	<b>167</b>	<b>6</b>
<b>7</b>	<b>Brake motors</b>	<b>193</b>	<b>7</b>
<b>8</b>	<b>Single phase motors</b>	<b>219</b>	<b>8</b>
<b>9</b>	<b>Integral motors</b>	<b>237</b>	<b>9</b>

ABB reserves the right to change the design, technical specification and dimensions without prior notice.

This pdf includes section 3, see complete pdf for other sections.

# General information

## Standards

ABB motors are of the totally enclosed and open drip proof, single or three phase squirrel cage type, built to comply with international IEC and EN standards. Motors conforming to other national and international specifications are also available on request.

All production units are certified to ISO 9001 international quality standard as well ISO 14000 environmental standard and confirm to all applicable EU Directives.

### IEC / EN

Electrical	Mechanical
IEC/EN 60034-1	IEC 60072
IEC/EN 60034-2	IEC/EN 60034-5
IEC 60034-8	IEC/EN 60034-6
IEC 60034-12	IEC/EN 60034-7
	IEC/EN 60034-9
	IEC 60034-14

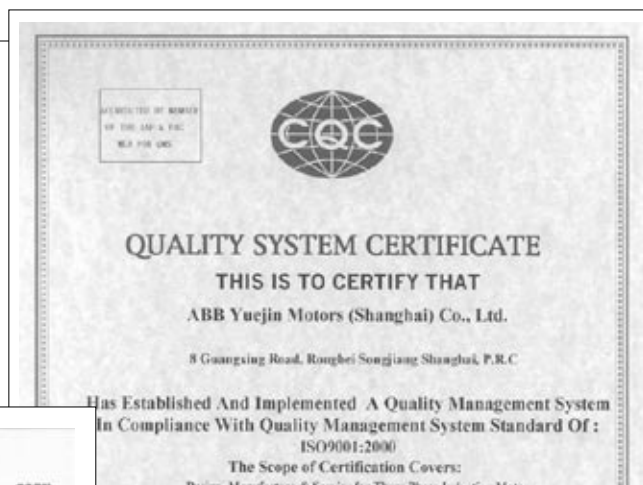

# Motors for EU motor efficiency levels

A Europe-wide agreement will ensure that the efficiency levels of electric motors manufactured in Europe are clearly displayed. In contrast to the American legislation on motor efficiency the European agreement does not establish mandatory efficiency levels.

It basically establishes three classes giving motor manufacturers an incentive to qualify for a higher class.

ABB is one of only a handful of leading motor manufacturers in Europe to have a motor range to meet or exceed the minimum efficiencies stated in the highest level of the EU agreement of LV motors.

These efficiency levels apply to 2- and 4-pole, three phase squirrel cage induction motors rated for 400V, 50Hz with S1 duty class with the output 1.1 to 90 kW, which

account for the largest volume on the market.

The efficiency of motors from different manufacturers are collated in a database, EURODEEM, published by the European Commission. It is accessible over the Internet at <http://iamest.jrc.it/projects/eem/eurodeem.htm>.

## EU efficiency classes for 2-pole motors

Output kW	2-pole Boarderline	
	EFF2/EFF3	EFF1/EFF2
1.1	76.2	82.8
1.5	78.5	84.1
2.2	81.0	85.6
3	82.6	86.7
4	84.2	87.6
5.5	85.7	88.6
7.5	87.0	89.5
11	88.4	90.5
15	89.4	91.3
18.5	90.0	91.8
22	90.5	92.2
30	91.4	92.9
37	92.0	93.3
45	92.5	93.7
55	93.0	94.0
75	93.6	94.6
90	93.9	95.0

## EU efficiency classes for 4-pole motors

Output kW	4-pole Boarderline	
	EFF2/EFF3	EFF1/EFF2
1.1	76.2	83.8
1.5	78.5	85.0
2.2	81.0	86.4
3	82.6	87.4
4	84.2	88.3
5.5	85.7	89.2
7.5	87.0	90.1
11	88.4	91.0
15	89.4	91.8
18.5	90.0	92.2
22	90.5	92.6
30	91.4	93.2
37	92.0	93.6
45	92.5	93.9
55	93.0	94.2
75	93.6	94.7
90	93.9	95.0

## ABB Three phase induction motors, 400 V 50 Hz - EU motor efficiency levels

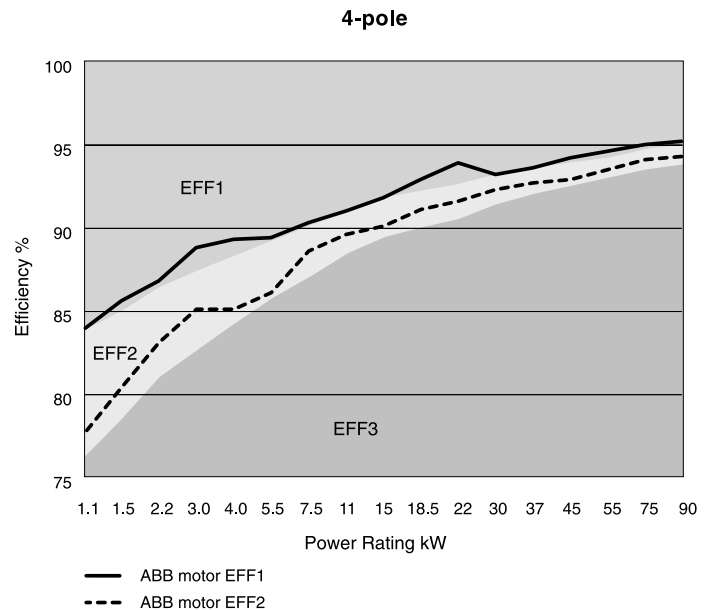
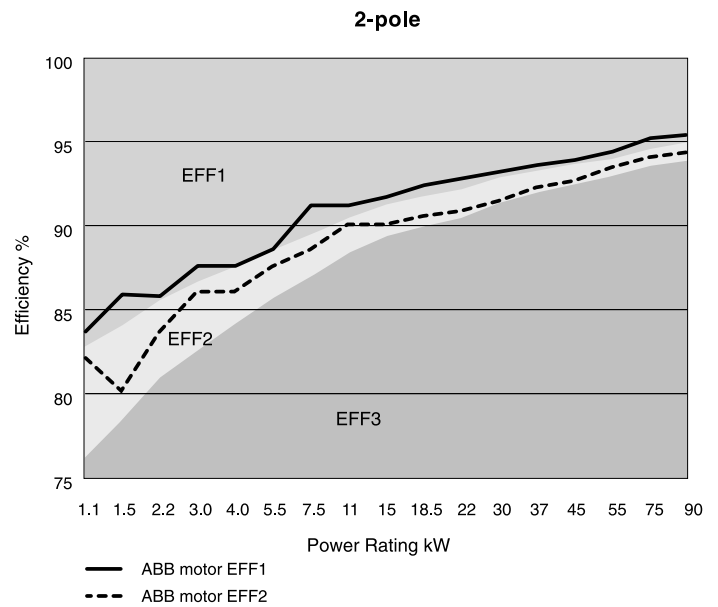

# General technical specification

## Mechanical and electrical design

### Mounting arrangements

1

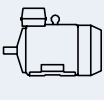
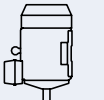
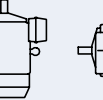
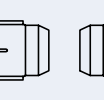
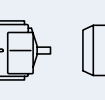
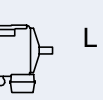
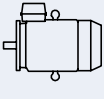
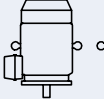
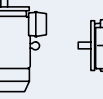
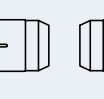
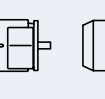
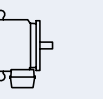
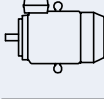
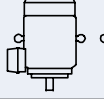
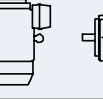
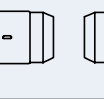
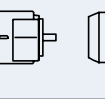
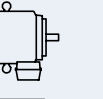
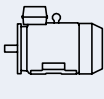
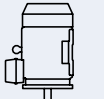
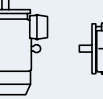
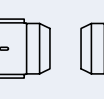
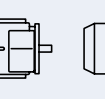
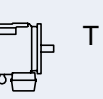
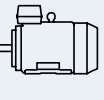
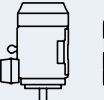
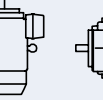
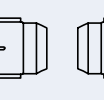
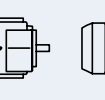
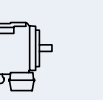
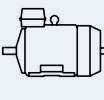
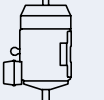
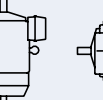
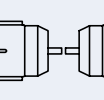
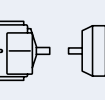
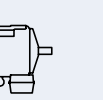
	Codell/Codell						Product code pos. 12
Foot-mounted motor.	IM B3 IM 1001	IM V5 IM 1011	IM V6 IM 1031	IM B6 IM 1051	IM B7 IM 1061	IM B8 IM 1071	A = foot-mounted, term.box top R = foot-mounted, term.box RHS L = foot-mounted, term.box LHS
							
Flange-mounted motor, large flange	IM B5 IM 3001	IM V1 IM 3011	IM V3 IM 3031	*) IM 3051	*) IM 3061	*) IM 3071	B = flange mounted, large flange
							
Flange-mounted motor, small flange	IM B14 IM 3601	IM V18 IM 3611	IM V19 IM 3631	*) IM 3651	*) IM 3661	*) IM 3671	C = flange mounted, small flange
							
Foot- and flange-mounted motor with feet, large flange	IM B35 IM 2001	IM V15 IM 2011	IM V36 IM 2031	*) IM 2051	*) IM 2061	*) IM 2071	H = foot/flange-mounted, term.box top S = foot/flange-mounted, term.box RHS T = foot/flange-mounted, term.box LHS
							
Foot- and flange-mounted motor with feet, small flange	IM B34 IM 2101	IM V17 IM 2111	IM 2131	IM 2151	IM 2161	IM 2171	J = foot/flange-mounted, small flange
							
Foot-mounted motor, shaft with free extensions	IM 1002	IM 1012	IM 1032	IM 1052	IM 1062	IM 1072	
							
*) Not stated in IEC 60034-7.							

# Cooling

Designation system concerning methods of cooling refers to standard IEC 60034-6.

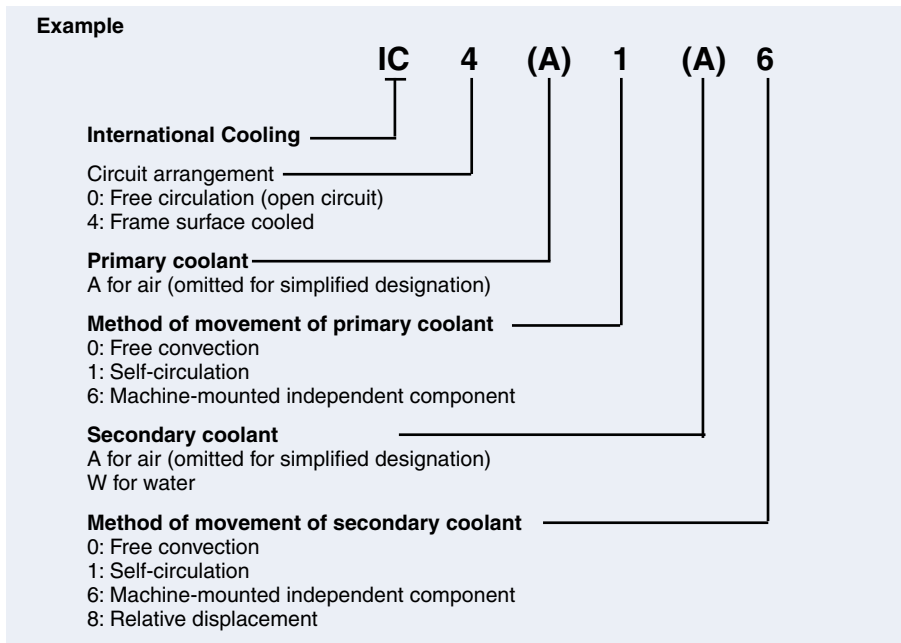

## Degrees of protection: IP code/IK code

Classification of degrees of protection provided by enclosures of rotating machines are refers to:

- Standard IEC 60034-5 or EN 60529 for IP code
- Standard EN 50102 for IK code

### IP protection:

Protection of persons against getting in contact with (or approaching) live parts and against contact with moving parts inside the enclosure. Also

protection of the machine against ingress of solid foreign objects. Protection of machines against the harmful effects due to the ingress of water

### IK code :

Classification of degrees of protection provided by enclosure for motors against external mechanical impacts.

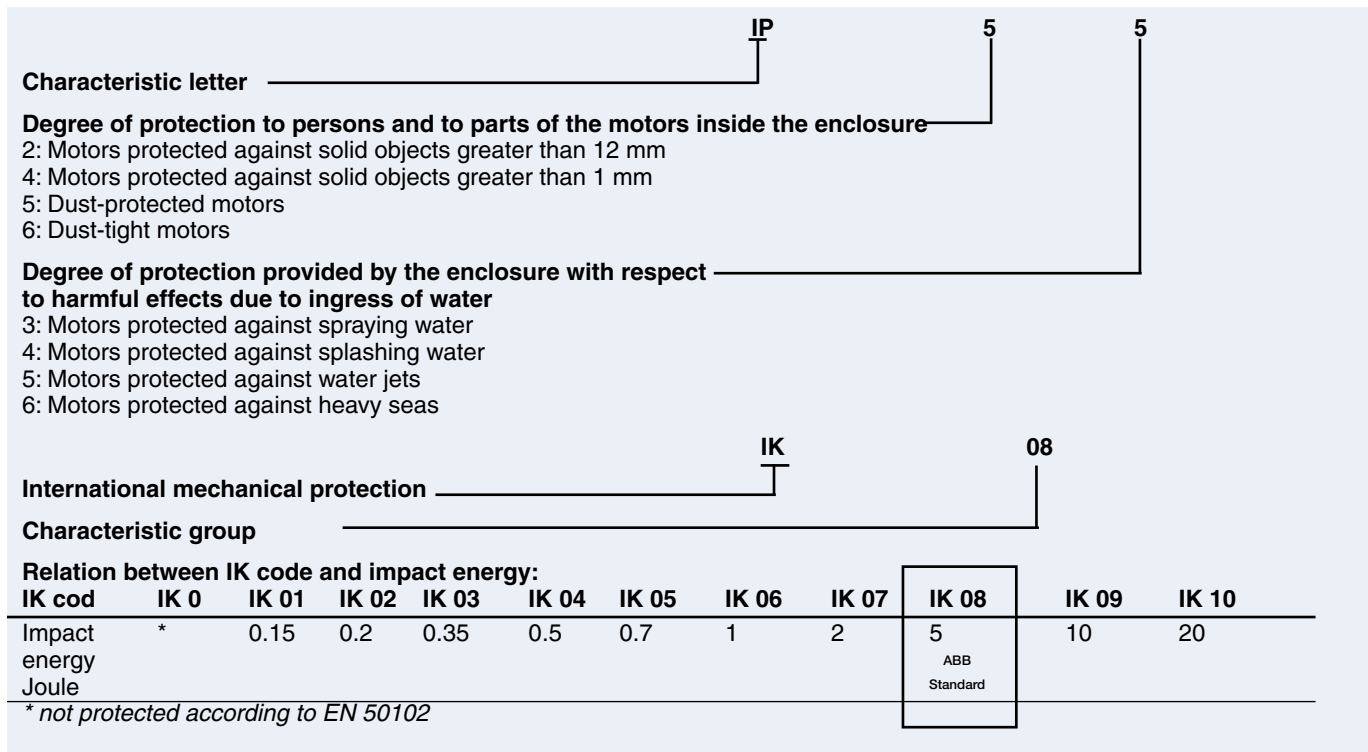

# Insulation

ABB uses class F insulation systems, which, with temperature rise B, is the most common requirement among industry today.

The use of Class F insulation with Class B temperature rise gives ABB products a 25° C safety margin. This can be used to increase the loading for limited periods, to operate at higher ambient temperatures or altitudes, or with greater voltage and frequency tolerances. It can also be used to extend insulation life. For instance, a 10 K temperature reduction will extend the insulation life.

## Class F insulation system

- Max ambient temperature 40° C
- Max permissible temperature rise 105 K
- Hotspot temperature margin + 10 K

## Class B rise

- Max ambient temperature 40° C
- Max permissible temperature rise 80 K
- Hotspot temperature margin + 10 K

## Insulation system temperature class

- Class F 155° C
- Class B 130° C
- Class H 180° C

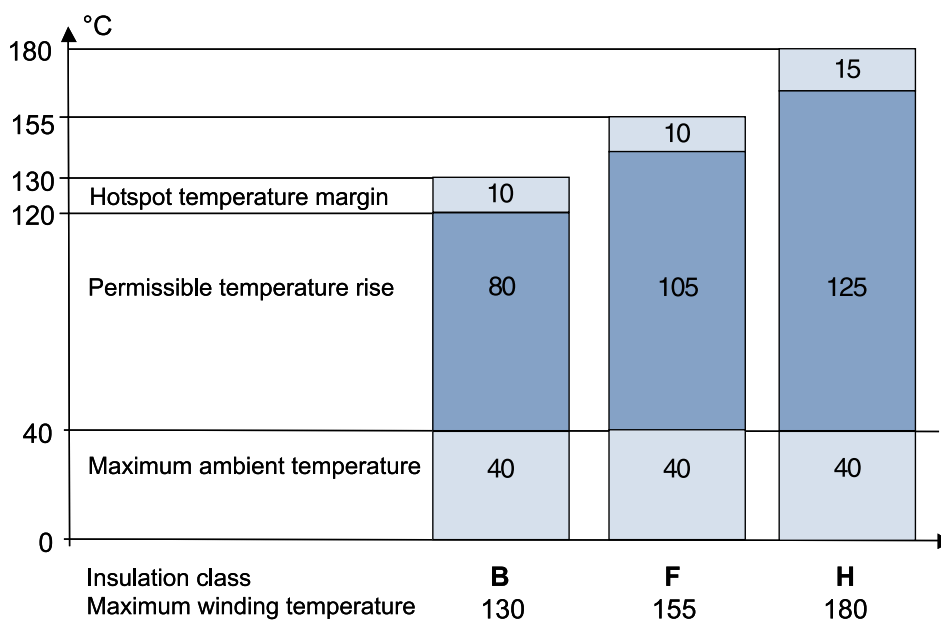

Safety margins per insulation class



# Frequency converter drives

Squirrel cage induction motors offer excellent availability, reliability and efficiency. With a frequency converter – a variable speed drive (VSD) – the motor will deliver even better value. A variable speed drive motor can be started softly with low starting current, and the speed can be controlled and adjusted to suit the application demand without steps over a wide range. Also the use of a frequency converter together with a squirrel cage motor usually leads to remarkable energy and environmental savings.

However, all motors are not suitable for variable speed drive. There are several points that have to be taken into account in the design and selection of the motor, if it is intended for variable speed operation.

Within the General purpose motor range ABB offers motors designed for both Direct On Line (DOL) and variable speed applications.

For more demanding applications the use of ABB Process performance motors is recommended.

The following points must be taken into account, when selecting a motor to a variable speed drive:

## 1. Dimensioning

The voltage (or current) fed by the frequency converter is not purely sinusoidal. This may increase the losses, vibration, and noise of the motor. Furthermore, a change in the distribution of the losses may affect to the temperature rise of the motor. In each case, the motor must be correctly sized according to the instructions supplied with the selected frequency converter.

When using ABB converters, please use ABB's DriveSize dimensioning programme or the loadability curves of the corresponding converter type for sizing the motors. The loadability curve for applicable General purpose motors used with ABB's ACS 600- and ACS 800- frequency converters can be found in figure 3.

## 2. Speed range

In a frequency converter drive, the actual operating speed of the motor may deviate considerably from its nominal speed (i.e. the speed stamped on the rating plate).

For higher speeds, ensure that the highest permissible rotational speed of the motor or the critical speed of the entire equipment is not exceeded. When high speed operation exceeds the nominal speed of the motor, the following points should be checked:

- Maximum torque of the motor
- Bearing construction
- Lubrication
- Balancing
- Critical speeds
- Shaft seals
- Ventilation
- Fan noise

Guideline values of maximum speeds for M3AA motors within the General purpose motor range are described in figure 1 below. Exact values are available on request.

Figure 1. Guideline values of maximum speeds for General purpose motor in aluminium frame:

Motor size	Speed r/min	
	2-pole	4-pole
M3AA 90-100	6000	6000
M3AA 112-200	4500	4500
M3AA 225-280	3600	3600

At low speed operation the motor's ventilation fan loses its cooling capacity, which causes a higher temperature rise in the motor and in the bearings. A separate constant speed fan can be used to increase cooling capacity and loadability at low speed. It is also important to check the performance of the grease at low speeds.

## 3. Lubrication

Variable speed operation affects on the bearing temperature, which must be taken into account when selecting the lubrication method and grease type. For example the life time of sealed bearings can be remarkably shorter than in direct on line operation. More information can be found from product specific sections of this catalogue and from ABB's Low Voltage Motors Manual.

## 4. Insulation protection

Frequency converter supply causes higher voltage stresses at the windings of the motor than the sinusoidal supply. Thus, the insulation system and possible filters must be selected according to the used voltage, cable length and converter type.

When using ABB's low voltage frequency converters, selection criterias mentioned in figure 2 must be followed.

## 5. Bearing currents

Bearing voltages and currents must be avoided in all motors. Assuming the use of ABB ACS 800 or ACS 550 drive, with uncontrolled DC-voltage, insulated bearings and/or properly dimensioned filters at the converter output must be used according to the instructions in figure 2. (For other alternatives and converter types, please contact ABB.) When ordering, clearly state which alternative will be used.

For more information about bearing currents and voltages, please contact ABB.

## 6. Cabling, grounding and EMC

The use of a frequency converter puts higher demands on the cabling and grounding of the drive system. The motor must be cabled by using shielded symmetrical cables and cable glands providing 360° bonding (also called EMC-glands). For motors up to 30 kW unsymmetrical cables can be used, but shielded cables are always recommended.

More information about grounding and cabling of a variable speed drive can be found from the manual

“Grounding and cabling of the drive system” (Code: 3AFY 61201998 R0125 REV A) and the ABB’s Low Voltage Motors Manual.

For fulfilling the EMC requirements, special EMC cable(s) must be used in addition to the correct cable gland mounting, with special, extra earthing pieces. Please refer to the manuals of the frequency converter.

### Validity

Measures mentioned in Figure 2 apply to the applicable motors within the General motors range (not high-output versions) with ACS 800 and ACS 550 drives with uncontrolled DC-voltage. For other alternatives and converter types, please contact ABB.

Figure 2. Selection rules for insulation and filtering in variable speed drives

	Motor nominal power $P_N$ or frame size		
	$P_N < 100 \text{ kW}$	$P_N \geq 100 \text{ kW}$ or $\geq \text{IEC 315}$	$P_N \geq 350 \text{ kW} \geq \text{IEC 450}$
$U_N \leq 500 \text{ V}$	Standard motor	Standard motor + Insulated N-bearing	Standard motor + Insulated N-bearing + Common mode filter
$U_N \leq 600 \text{ V}$	Standard motor + dU/dt-filter <b>OR</b> Reinforced insulation	Standard motor + dU/dt-filter (reactor) + Insulated N-bearing <b>OR</b> Reinforced insulation + Insulated N-bearing	Standard motor + Insulated N-bearing + dU/dt-filter + Common mode filter <b>OR</b> Reinforced insulation + Insulated N-bearing + Common mode filter
$U_N \leq 690 \text{ V}$	Reinforced insulation + dU/dt-filter	Reinforced insulation + dU/dt-filter (reactor) + Insulated N-bearing	Reinforced insulation + Insulated N-bearing + dU/dt-filter + Common mode filter

### dU/dt filter (reactor)

Series reactor. DU/dt -filter decreases the changing rate of the phase and main voltages and thus reduces voltage stresses in the windings. DU/dt -filters also decrease so-called common mode currents and the risk of bearing currents.

### Common mode filters

Common mode filters reduce so-called common mode currents in VSD applications and thus decrease the risk of bearing currents. Common mode filters do not significantly affect the phase or main voltages on the motor terminals.

### Insulated Bearings

Bearings with insulated inner or outer races are used as the standard solution. So-called hybrid bearings, i.e. bearings with non-conductive ceramic balls, can also be used in special applications. More information for spare part selection is available on request.

Figure 3. Motor loadability with ACS 600 and ACS 800, Field weakening point 50 Hz.

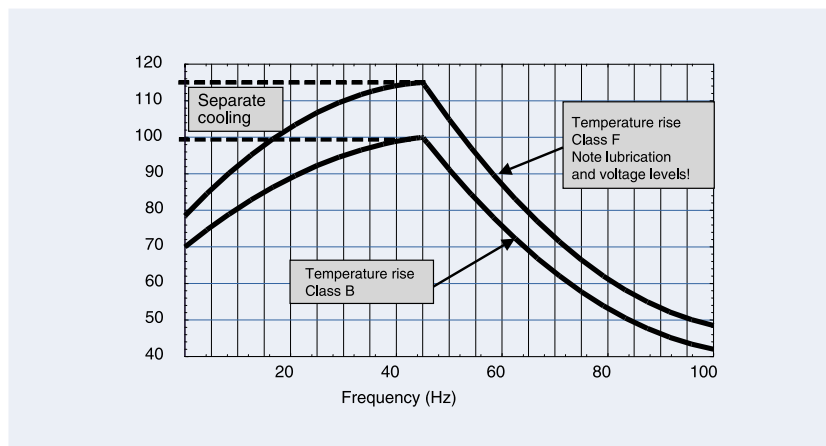

# General Purpose Steel Motors

Totally enclosed squirrel cage three phase low voltage motors,  
Sizes 280 - 400, 75 to 630 kW

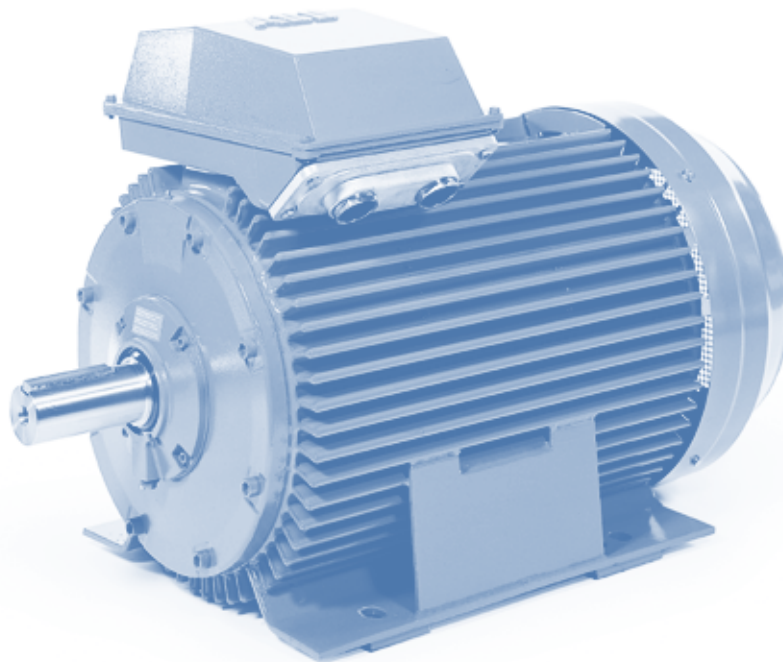

3

[www.abb.com/motor&drives](http://www.abb.com/motor&drives)

- > Motors
- > Low voltage motors
- > General purpose motors

Mechanical design.....	82
Ordering information.....	89
Technical data.....	90
Variant codes .....	95
Dimension drawings .....	98
Rating plates .....	108
Steel motors in brief.....	111

# Mechanical design

## Stator

The stator frame is made of profile-pressed sheet steel, giving the motor high mechanical strength, low weight and a good surface finish. The stator core is welded into the stator frame and contributes to its excellent mechanical properties.

Feet and lifting eyes are welded to the stator frame. The terminal box and end shields are of cast iron.

## Drain holes

Motors that will be operated in very humid or wet environments, and especially under intermittent duty, should be provided with drain holes. The appropriate IM designation, such as IM V3 (IM 3031), is specified, on the basis of the method of motor mounting.

plugs are open on delivery. Check that the drain holes and grease outlet face downwards, when mounting designation differs from standard horizontal mounting.

In the case of vertical mounting, the upper plug must be hammered home completely. In very dusty environments the drain hole plug should be knocked in.

**3** M2CA motors are fitted with drain holes and plugs. The

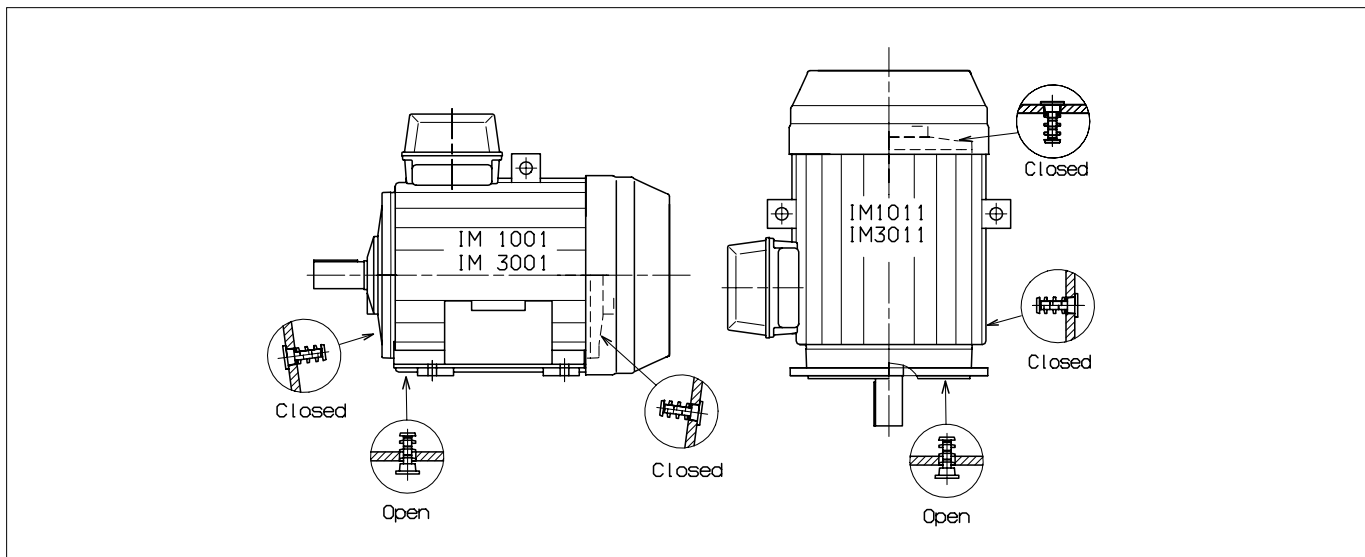

## Terminal box

Terminal boxes are mounted either on the top of the motor, or on either side of the motor, see ordering information.

In basic version the terminal box can be rotated  $2 \times 180^\circ$  to allow cable entry from either side of the motor, as option the terminal box can be turned  $4 \times 90^\circ$ .

Degree of protection of standard terminal box is IP 55.

The terminal box is equipped with cable glands or cable boxes as standard, and terminations are suitable for Cu- and Al-cables. Cables are connected to the terminals by cable lugs which are not included with the motor.

To enable us to supply suitable terminations for the motor please state cable type, quantity and size when ordering. Non-standard design of terminal boxes; e.g. size, degree of protection, are available as options.

Please see variant codes for options and dimension drawings of terminal boxes.

# Co-ordination of terminal boxes and cable entries

If no ordering information on the cable is given, it is assumed to be p.v.c. -insulated type and termination parts are supplied according to the table below and on next page.

Deviations from standard design according to the following tables are available on request.

## M2CA 280-400 motors with top-mounted terminal box Standard cable entries and cable boxes

Voltage 220 - 690 V, 50 Hz

Motor size M2CA	Terminal box	Flange or adapter	Cable box or cable gland	Gland thread	Cable diameter	Max. connection cable area mm <sup>2</sup>	Terminal bolt size	Voltage/freq. code
<b>3000 r/min (2 poles)</b>								
280	122/4	3GZF 294730-749	2x 3GZF 294730-613	2x M63x1.5	2x Ø32-49	2x150	M12	
315 S, M, LA, LB	142/4	3GZF 294730-753	2x 3GZF 294730-613	2x M63x1.5	2x Ø32-49	2x240	M12	
315 LC	162/4	3GZF 294730-944	3GZF 294730-301		2x Ø48-60	4x240	M12	
355 SA	142/4	3GZF 294730-753	2x 3GZF 294730-613	2x M63x1.5	2x Ø32-49	2x240	M12	
355 M	162/4	3GZF 294730-944	3GZF 294730-301		2x Ø48-60	4x240	M12	D
	142/4	-	3GZF 294730-301		2x Ø48-60	2x240	M12	E
355 L	162/4	3GZF 294730-944	3GZF 294730-301		2x Ø48-60	4x240	M12	
400 M	162/4	3GZF 294730-944	3GZF 294730-501		2x Ø60-80	4x240	M12	
400 LK	162/9	3GZF 294730-944	3GZF 294730-501		2x Ø60-80	4x240	M12	
<b>1500 r/min (4 poles)</b>								
280	122/4	3GZF 294730-749	2x 3GZF 294730-613	2x M63x1.5	2x Ø32-49	2x150	M12	
315 S, M, LA, LB	142/4	3GZF 294730-753	2x 3GZF 294730-613	2x M63x1.5	2x Ø32-49	2x240	M12	
315 LC	162/4	3GZF 294730-944	3GZF 294730-301		2x Ø48-60	4x240	M12	
355 SA	142/4	3GZF 294730-753	2x 3GZF 294730-613	2x M63x1.5	2x Ø32-49	2x240	M12	
355 M	162/4	3GZF 294730-944	3GZF 294730-301		2x Ø48-60	4x240	M12	D
	142/4	-	3GZF 294730-301		2x Ø48-60	2x240	M12	E
355 LA, LB	162/4	3GZF 294730-944	3GZF 294730-301		2x Ø48-60	4x240	M12	
355 LKD	162/4	3GZF 294730-944	3GZF 294730-501		2x Ø60-80	4x240	M12	
400 M	162/4	3GZF 294730-944	3GZF 294730-501		2x Ø60-80	4x240	M12	
400 LKA	162/9	3GZF 294730-944	3GZF 294730-501		2x Ø60-80	4x240	M12	D
	162/4	3GZF 294730-944	3GZF 294730-501		2x Ø60-80	4x240	M12	E
400 LKB, LKC	162/9	3GZF 294730-944	3GZF 294730-501		2x Ø60-80	4x240	M12	
<b>1000 r/min (6 poles)</b>								
280	122/4	3GZF 294730-749	2x 3GZF 294730-613	2x M63x1.5	2x Ø32-49	2x150	M12	
315 S, M, LA, LB	142/4	3GZF 294730-753	2x 3GZF 294730-613	2x M63x1.5	2x Ø32-49	2x240	M12	
355 SA, SB	142/4	3GZF 294730-753	2x 3GZF 294730-613	2x M63x1.5	2x Ø32-49	2x240	M12	
355 MA	142/4	-	3GZF 294730-301		2x Ø48-60	2x240	M12	
355 MB	162/4	3GZF 294730-944	3GZF 294730-301		2x Ø48-60	4x240	M12	D
	142/4	-	3GZF 294730-301		2x Ø48-60	2x240	M12	E
355 LKD	162/4	3GZF 294730-944	3GZF 294730-301		2x Ø48-60	4x240	M12	
400 MLA	162/4	3GZF 294730-944	3GZF 294730-301		2x Ø60-80	4x240	M12	D
400 MLB	162/4	-	3GZF 294730-501		2x Ø48-60	2x240	M12	E
400 LK	162/9	3GZF 294730-944	3GZF 294730-501		2x Ø60-80	4x240	M12	D
400 LK	162/4	3GZF 294730-944	3GZF 294730-501		2x Ø60-80	4x240	M12	E
<b>750 r/min (8 poles)</b>								
280	122/4	3GZF 294730-749	2x 3GZF 294730-613	2x M63x1.5	2x Ø32-49	2x150	M12	
315	142/4	3GZF 294730-753	2x 3GZF 294730-613	2x M63x1.5	2x Ø32-49	2x240	M12	
355 SA, SB	142/4	3GZF 294730-753	2x 3GZF 294730-613	2x M63x1.5	2x Ø32-49	2x240	M12	
355 MA	142/4	-	3GZF 294730-301		2x Ø48-60	2x240	M12	
355 MB	142/4	-	3GZF 294730-301		2x Ø48-60	4x240	M12	D
355 MB	142/4	-	3GZF 294730-301		2x Ø48-60	2x240	M12	E
355 LKD	162/4	-	3GZF 294730-301		2x Ø48-60	4x240	M12	
400 MLA	162/4	3GZF 294730-944	3GZF 294730-301		2x Ø48-60	4x240	M12	D
	142/4	-	3GZF 294730-301		2x Ø48-60	2x240	M12	E
400 LKA	162/4	3GZF 294730-944	3GZF 294730-501		2x Ø60-80	4x240	M12	

Voltage/frequency codes:

- D - 380-420 VD 50 Hz, 660-690 VY 50 Hz, 440-480 VD 60 Hz
- E - 500 VD 50 Hz, 575 VD 60 Hz

Examples:

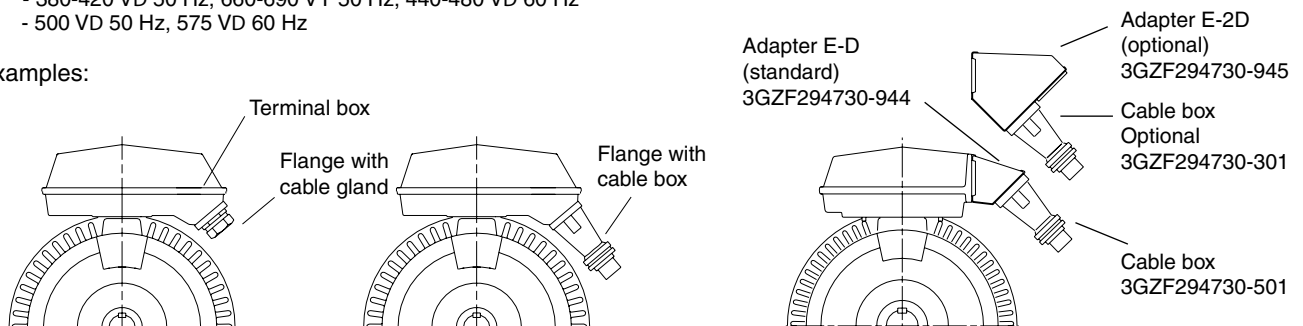

# M2CA motors with side-mounted terminal box:

## Standard cable entries and cable boxes

Voltage 220 - 690 V, 50 Hz

Motor size M2CA	Terminal box	Flange or adapter	Cable box or cable gland	Gland thread	Cable diameter	Max. connection cable area mm <sup>2</sup>	Terminal bolt size	Voltage/freq. code
<b>3000 r/min (2 poles)</b>								
280	122/5	3GZF 294730-749	2x 3GZF 294730-613	<b>2x M63x1.5</b>	2x Ø32-49	2x150	M12	
315 S_,M_,LA,LB	142/6	3GZF 294730-753	2x 3GZF 294730-613	<b>2x M63x1.5</b>	2x Ø32-49	2x240	M12	
315 LC	162/7	3GZF 294730-759	3GZF 294730-301		2x Ø48-60	4x240	M12	
355 SA	142/6	3GZF 294730-753	2x 3GZF 294730-613	<b>2x M63x1.5</b>	2x Ø32-49	2x240	M12	
355 M_	162/7	3GZF 294730-759	3GZF 294730-301		2x Ø48-60	4x240	M12	D
	142/6	-	3GZF 294730-301		2x Ø48-60	2x240	M12	E
355 L_	162/7	3GZF 294730-759	3GZF 294730-301		2x Ø48-60	4x240	M12	
400 M_	162/7	3GZF 294730-759	3GZF 294703-501		2x Ø60-80	4x240	M12	
400 LK_	162/7	3GZF 294730-759	3GZF 294703-501		2x Ø60-80	4x240	M12	
<b>1500 r/min (4 poles)</b>								
280	122/5	3GZF 294730-749	2x 3GZF 294730-613	<b>2x M63x1.5</b>	2x Ø32-49	2x150	M12	
315 S_,M_,LA,LB	142/6	3GZF 294730-753	2x 3GZF 294730-613	<b>2x M63x1.5</b>	2x Ø32-49	2x240	M12	
315 LC	162/7	3GZF 294730-759	3GZF 294730-301		2x Ø48-60	4x240	M12	
355 SA	142/6	3GZF 294730-753	2x 3GZF 294730-613	<b>2x M63x1.5</b>	2x Ø32-49	2x240	M12	
355 M_	162/7	3GZF 294730-759	3GZF 294730-301		2x Ø48-60	4x240	M12	D
	142/6	-	3GZF 294730-301		2x Ø48-60	2x240	M12	E
355 LA, LB	162/7	3GZF 294730-759	3GZF 294730-301		2x Ø48-60	4x240	M12	
355 LKD	162/7	3GZF 294730-759	3GZF 294703-501		2x Ø60-80	4x240	M12	
400 M_	162/7	3GZF 294730-759	3GZF 294703-501		2x Ø60-80	4x240	M12	
400 LKA	162/7	3GZF 294730-759	3GZF 294703-501		2x Ø60-80	4x240	M12	D
	162/7	3GZF 294730-759	3GZF 294703-501		2x Ø60-80	4x240	M12	E
400 LKB, LKC	162/7	3GZF 294730-759	3GZF 294703-501		2x Ø60-80	4x240	M12	
<b>1000 r/min (6 poles)</b>								
280	122/5	3GZF 294730-749	2x 3GZF 294730-613	<b>2x M63x1.5</b>	2x Ø32-49	2x150	M12	
315 S_,M_,LA,LB	142/6	3GZF 294730-753	2x 3GZF 294730-613	<b>2x M63x1.5</b>	2x Ø32-49	2x240	M12	
355 SA,SB	142/6	3GZF 294730-753	2x 3GZF 294730-613	<b>2x M63x1.5</b>	2x Ø32-49	2x240	M12	
355 MA	142/6	-	3GZF 294730-301		2x Ø48-60	2x240	M12	
355 MB	162/7	3GZF 294730-759	3GZF 294730-301		2x Ø48-60	4x240	M12	D
	142/6	-	3GZF 294730-301		2x Ø48-60	2x240	M12	E
355 LKD	162/7	3GZF 294730-759	3GZF 294730-301		2x Ø48-60	4x240	M12	
400 ML_	162/7	3GZF 294730-759	3GZF 294703-501		2x Ø60-80	4x240	M12	D
	142/6	-	3GZF 294730-301		2x Ø48-60	2x240	M12	E
400 LK_	162/7	3GZF 294730-759	3GZF 294703-501		2x Ø60-80	4x240	M12	
<b>750 r/min (8 poles)</b>								
280	122/5	3GZF 294730-749	2x 3GZF 294730-613	<b>2x M63x1.5</b>	2x Ø32-49	2x150	M12	
315	142/6	3GZF 294730-753	2x 3GZF 294730-613	<b>2x M63x1.5</b>	2x Ø32-49	2x240	M12	
355 SA, SB	142/6	3GZF 294730-753	2x 3GZF 294730-613	<b>2x M63x1.5</b>	2x Ø32-49	2x240	M12	
355 MA	142/6	-	3GZF 294730-301		2x Ø48-60	2x240	M12	
355 MB	162/7	3GZF 294730-759	3GZF 294730-301		2x Ø48-60	4x240	M12	D
	142/6	-	3GZF 294730-301		2x Ø48-60	2x240	M12	E
355 LKD	162/7	3GZF 294730-759	3GZF 294730-301		2x Ø48-60	4x240	M12	D
400 MLA	162/7	3GZF 294730-759	3GZF 294730-301		2x Ø48-60	4x240	M12	D
	142/6	-	3GZF 294730-301		2x Ø48-60	2x240	M12	E
400 LK_	162/7	3GZF 294730-759	3GZF 294703-501		2x Ø60-80	4x240	M12	

Voltage/frequency codes:

D - 380-420 VD 50 Hz, 660-690 VY 50 Hz, 440-480 VD 60 Hz

E - 500 VD 50 Hz, 575 VD 60 Hz

Examples:

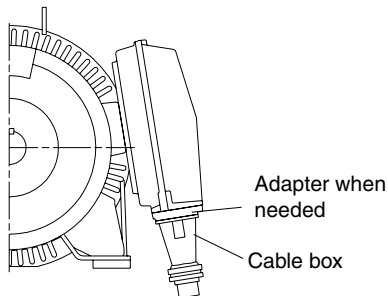
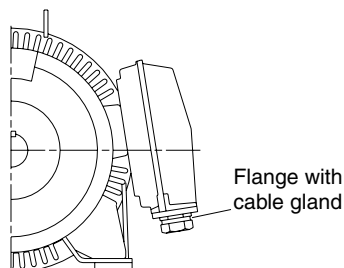

**Auxiliary devices (view from N-end):**

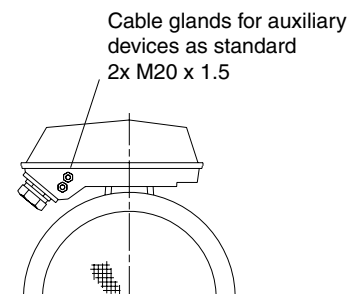

## Alternatives for cable entries and cable boxes

The tables on previous pages show the standard terminal boxes and termination parts that are delivered when no information on the cable is given.

The table below shows the different alternatives avail-

able for cable boxes and cable entries. Other types on request.

Motor size	Terminal box on top	Terminal box on side	Opening type	Max. rated current A ( $\Delta/Y$ -conn.)	Max. size of conductor mm <sup>2</sup>	Cable gland	Cable box	Blank plate
280	122/4	122/5	C (FL 21)	360/210	2x150	2xPg29...42	1x $\varnothing$ 36...52/ $\varnothing$ 48...60	MKLN 20
315 S_, M_, LA, LB	142/4	142/6	D (FL33)	640/370	2x240	1xPg36...42 2xPg36...48	1x $\varnothing$ 36...52/ $\varnothing$ 48...60 2x $\varnothing$ 48...60/ $\varnothing$ 50...68 2x $\varnothing$ 68...80	MKLN 30
315 LC 355, 400	142/4	142/6	D (FL33)	640/370	2x240	1xPg36...42 2xPg36...48	1x $\varnothing$ 36...52/ $\varnothing$ 48...60 2x $\varnothing$ 48...60/ $\varnothing$ 50...68 2x $\varnothing$ 68...80	MKLN 30
	162/4	162/7	E-D <sup>1)</sup>	950/550	4x240	2xPg36...48 1xPg36...42	1x $\varnothing$ 36...52/ $\varnothing$ 48...60 2x $\varnothing$ 48...60/ $\varnothing$ 50...68 2x $\varnothing$ 68...80	
	162/4	162/7	E-D <sup>1)</sup>	1300/750	4x240	2xPg36...48 1xPg36...42	1x $\varnothing$ 36...52/ $\varnothing$ 48...60 2x $\varnothing$ 48...60/ $\varnothing$ 50...68 2x $\varnothing$ 68...80	
	162/4	162/7	E-2D <sup>1)</sup>	1300/750	4x240	2x2xPg36...48 2x1xPg36...42	2x1x $\varnothing$ 36...52/ $\varnothing$ 48...60 2x2x $\varnothing$ 48...60/ $\varnothing$ 50...68 2x2x $\varnothing$ 68.m.80	

<sup>1)</sup> Terminal box type 162 is used with a combination of one E-opening and one or two D-openings, see pictures below and drawing pages.

**Terminal box 162 with adapting flange 3GZF 294730-501 (E-D) or optional 3GZF 294730-301 (E-2D) :**

**Terminal box 162 with adapting flange:**

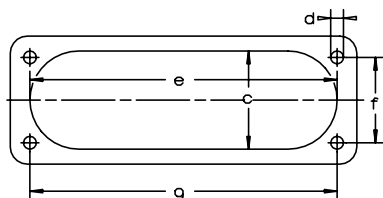
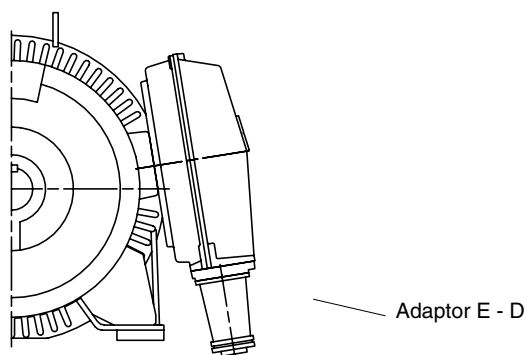
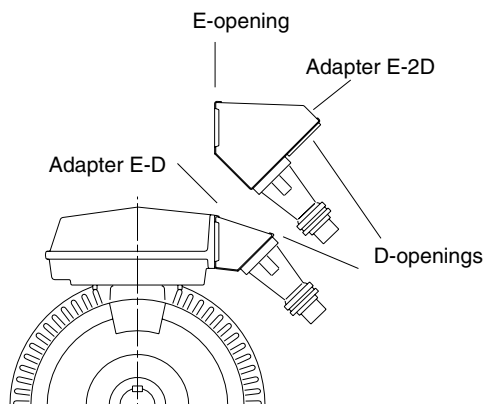

Opening	c	e	f	g	d
C (FL 21)	62	193	62	193	M8
D (FL 33)	100	300	80	292	M10
E (FL 40)	115	370	100	360	M12

## Bearings

The motors are normally fitted with single-row deep groove ball bearings as listed in the table below. The complete ball bearing designation is stated on the rating plate.

If the bearing at the D-end is replaced with a roller bearing (NU- or NJ-), higher radial forces can be handled. Roller bearings are suitable for belt drive applications.

When there are high axial forces, angular contact ball bearings should be used. This option is available on request. When a motor with angular contact ball bearings is ordered, the method of mounting and direction and magnitude of the axial force must be specified. For special bearings, please see the variant codes.

### Bearing types

Motor size	Number of poles	Standard design Deep groove ball bearings		Alternative designs
		D-end	N-end	Roller bearings variant code 037 D-end
280	2	6316/C4	6316/C4	1)
	4-12	6316/C3	6316/C3	NU 316/C3
315	2	6316/C4	6316/C4	1)
	4-12	6319/C3	6316/C3	NU319/C3
355	2	6316M/C4	6316M/C4	1)
	4-12	6322/C3	6319/C3	NU 322/C3
400	2	6317M/C4	6317M/C4	1)
	4-12	6322/C3	6319/C3	NU 322/C3

1) On request

## Axially-locked bearings

The outer bearing ring at the D-end is axially locked with an inner bearing cover. The inner ring is locked by tight tolerance to the shaft.

All motors are equipped as standard with an axially-locked bearing at the D-end.

## Transport locking

Motors that have roller bearings or an angular contact ball bearing are fitted with a transport lock before despatch to prevent damage to the bearings during transport. In case of transport locked bearing, the motor is provided with a warning sign.

Locking may also be fitted in other cases where transport conditions are suspected of being potentially damaging.



# Bearing seals

M2CA motors have, as standard, V-rings at both ends. The size and type of suitable seals are in accordance with the table below:

Motor size	Number of poles	d <sub>1</sub>	d <sub>2</sub>	B <sub>1</sub>	b	Standard design		Alternative design Radial seal (DIN 3760) Variant code 072
						Axial seal D-end	N-end	
280	2	80	100	13.5	10	VS 80	VS 80	80x100x10 <sup>1)</sup>
	4-12	80	100	13.5	10	VS 80	VS 80	80x100x10
315	2	80	100	13.5	10	VS 80	VS 80	80x100x10 <sup>1)</sup>
	4-12	95	120	13.5	12	VS 95	VS 80	95x120x12
355	2	95	120	13.5	12	VS 80	VS 80	80x100x10 <sup>1)</sup>
	4-12	110	140	15.5	12	VS 110	VS 95	110x140x12 <sup>1)</sup>
400	2	95	120	13.5	12	VS 85	VS 85	85x110x12 <sup>1)</sup>
	4-12	110	140	15.5	12	VS 110	VS 95	110x140x12 <sup>1)</sup>

<sup>1)</sup> Viton-seal

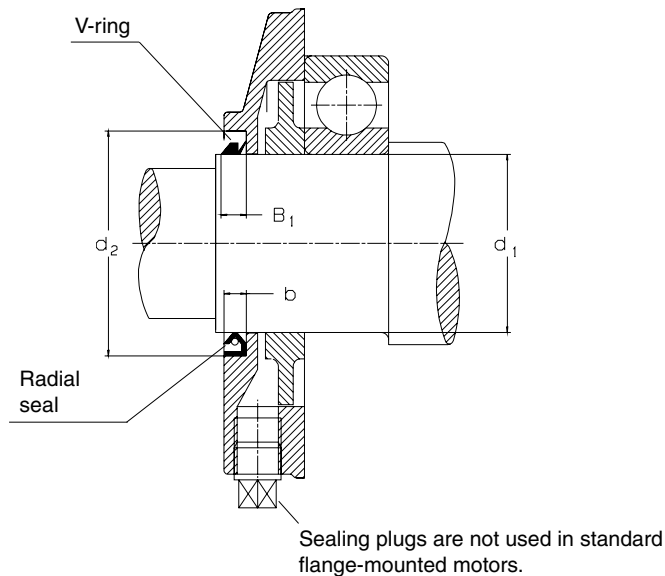

## Bearing life

The nominal life L<sub>10</sub> of a bearing is defined according to ISO as the number of operating hours achieved or exceeded by 90% of identical bearings in a large test series under certain specified conditions. 50% of the bearings achieve at least five times this figure.

The calculated bearing life L<sub>10</sub> for power transmission by means of a coupling (horizontal machine):  
Motor sizes M2CA 280 to 400 ≥ 200.000 hours.

## Pulley diameter

When the desired bearing life has been determined, the minimum permissible pulley diameter can be calculated using F<sub>R</sub>, as follows:

$$D = \frac{1.9 \cdot 10^7 \cdot K \cdot P}{n \cdot F_R}$$

where:

D = diameter of pulley, mm

P = power requirement, kW

n = motor speed, r/min

K = belt tension factor, dependent on belt type and type of duty. A common value for V-belts is 2.5.

F<sub>R</sub> = permissible radial force

# Permissible loading on shaft

The table below gives the permissible radial and axial forces in Newtons, assuming the occurrence of only radial or axial force. In case of simultaneous radial and axial forces, information can be supplied on request. The values are based on normal conditions at 50 Hz and calculated bearing lives of 40,000 h.

Motors are B3 version with force directed sideways. In some cases the strength of the shaft affects the permissible forces.

At 60 Hz the values must be reduced by 10 %. For two-speed motors, the values must be based on the higher speed. When there are high axial forces, angular contact ball bearings should be used.

Permissible loads of simultaneous radial and axial forces will be supplied on request.

## Permissible radial and axial force for a bearing life of 40,000 hours

Motor size	Number of poles	Length of shaft extension E (mm)	Permissible radial force:				Permissible axial force:		
			Horizontal mounting, sideways direction of force				Horizontal mounting	Vertical mounting with shaft extension downwards	
			Ball bearing at point of application:		Roller bearing at point of application:		Direction of force		
			FX <sub>0</sub>	FX <sub>max</sub>	FX <sub>0</sub>	X <sub>max</sub>	Outwards	Upwards	Downwards
N	N	N	N	N	N	N			
280	2	140	5800	4800	—	—	3700	7050	2600
	4	140	7300	6100	20000	10500	4000	7650	2800
	6	140	8300	6800	22500	10500	4900	8800	3400
	8	140	9200	7500	24700	10500	5700	9750	4100
315	2	140	5800	4900	—	—	3600	7400	1800
	4	170	8900	7300	26500	10500	4900	9200	2800
	6	170	10300	8500	29800	10500	6150	10700	3300
	8	170	11300	9300	32500	11000	6900	11800	4300
355	2	140	5800	5100	—	—	2400	<sup>1)</sup>	<sup>1)</sup>
	4	210	12000	9800	36700	17500	3900	<sup>1)</sup>	<sup>1)</sup>
	6	210	13500	11300	41500	17000	5100	<sup>1)</sup>	<sup>1)</sup>
	8	210	15000	12500	45200	17500	6350	<sup>1)</sup>	<sup>1)</sup>
400	2	170	5800	5100	—	—	6700	<sup>1)</sup>	<sup>1)</sup>
	4	210	11800	10200	37300	16700	3450	<sup>1)</sup>	<sup>1)</sup>
	6	210	13600	11700	42000	13500	4750	<sup>1)</sup>	<sup>1)</sup>
	8	210	15100	12900	45700	16800	5700	<sup>1)</sup>	<sup>1)</sup>

<sup>1)</sup> On request

If the radial force is applied between points X<sub>0</sub> and X<sub>max</sub>, the permissible force F<sub>R</sub> can be calculated from the following formula:

$$F_R = F_{X0} - \frac{X}{E} (F_{X0} - F_{Xmax})$$

E = length of shaft extension in basic version

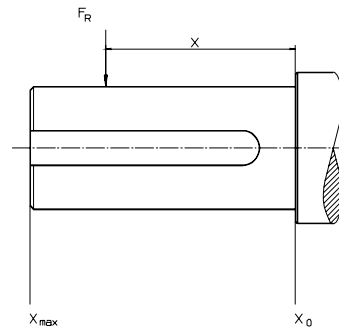

# Ordering information

When placing an order, please state the following minimum data in the order, as in the example.

The product code of the motor is composed in accordance with the following example.

Motor type	M2CA 315SMA
Pole number	4
Mounting arrangement (IM-code)	IM B3 (IM 1001)
Rated output	132 kW
Product code	3GCA312210-ADA
Variant codes if needed	

<b>A</b>	<b>B</b>	<b>C</b>	<b>D,E,F, G</b>	<b>A</b> Motor type
<b>M2CA</b>	<b>315 SMA</b>	<b>3GCA 312 210 - ADA, 003 etc.</b>		<b>B</b> Motor size
				<b>C</b> Product code
				<b>D</b> Mounting arrangement code
				<b>E</b> Voltage/frequency code
				<b>F</b> Generation code
				<b>G</b> Variant code

## Explanation of the product code:

### Positions 1 to 4

**3GCA** = Totally enclosed fan cooled squirrel cage motor with steel stator frame

### Positions 5 and 6

IEC-size

**28** = 280

**35** = 355

**31** = 315

**40** = 400

### Position 7

Speed (Pole pairs)

**1** = 2 poles

**6** = 12 poles

**2** = 4 poles

**7** = > 12 poles

**3** = 6 poles

**8** = Two-speed motors

**4** = 8 poles

**9** = Multi-speed motors

**5** = 10 poles

### Position 8 to 10

Serial number

### Position 11

- (dash)

### Position 12

Mounting arrangement

**A** = Foot-mounted, top-mounted terminal box

**R** = Foot-mounted, terminal box RHS seen from D-end

**L** = Foot-mounted, terminal box LHS seen from D-end

**B** = Flange-mounted, large flange

**H** = Foot- and flange-mounted, top-mounted terminal box

**S** = Foot- and flange-mounted, terminal box RHS seen from D-end

**T** = Foot- and flange-mounted, terminal box LHS seen from D-end

### Position 13

Voltage and frequency code

See table below

### Position 14

Generation code = A

**The product code must be, if needed, followed by variant codes.**

## Code letters for supplementing the product code for voltage and frequency:

A	B	D	E	F	H
380 VY 50 Hz	380 VΔ 50 Hz	380-420 VΔ 50 Hz 660-690 VY 50 Hz 440-480 VΔ 60 Hz	500 VΔ 50 Hz 575 VΔ 60 Hz	500 VY 50 Hz 575 VY 60 Hz	415 VΔ 50 Hz
S	T	U	X		
220-240 VΔ 50 Hz 380-420 VY 50 Hz 440-480 VY 60 Hz	660 VΔ 50 Hz	690 VΔ 50 Hz	Other rated voltage, connection or frequency, max. 690 V		

# General purpose steel motors

## Technical data for totally enclosed squirrel cage three phase motors

IP 55 – IC 411 – Insulation class F, temperature rise class B

Output kW	Motor type	Product code	Speed r/min	Efficiency		Power factor cos φ 100%	Current		Torque			
				Full load 100%	3/4 load 75%		I <sub>N</sub> A	I <sub>s</sub> A	T <sub>N</sub> Nm	T <sub>s</sub> Nm	T <sub>max</sub> Nm	
<b>3000 r/min = 2-poles</b>			<b>400 V 50 Hz</b>				<b>Basic design</b>					
75	M2CA 280 SA	3GCA 281 110-••A	2977	94.9	94.6	0.88	131	7.5	241	2.3	3.30	
90	M2CA 280 SMA	3GCA 281 210-••A	2975	95.1	94.9	0.90	152	7.6	289	2.3	2.90	
110	M2CA 315 SA	3GCA 311 110-••A	2982	95.1	94.4	0.86	194	7.6	352	2.0	3.00	
132	M2CA 315 SMA	3GCA 311 210-••A	2982	95.4	94.9	0.88	228	7.4	423	2.2	3.00	
160	M2CA 315 MB	3GCA 311 320-••A	2981	96.1	95.6	0.89	269	7.5	513	2.3	3.00	
200	M2CA 355 SA	3GCA 351 110-••A	2977	95.5	95.1	0.92	330	6.6	641	1.3	2.80	
200 <sup>2)</sup>	M2CA 315 LA	3GCA 311 510-••A	2978	96.3	95.9	0.90	334	7.8	641	2.6	3.00	
250	M2CA 355 MA	3GCA 351 310-••A	2980	96.1	95.7	0.92	410	6.6	801	1.3	3.00	
280	M2CA 355 MB	3GCA 351 320-••A	2978	96.1	95.9	0.92	470	5.7	897	1.1	2.70	
315	M2CA 355 LA	3GCA 351 510-••A	2980	96.6	96.4	0.93	510	7.7	1009	1.3	3.30	
355	M2CA 355 LB	3GCA 351 520-••A	2977	96.0	95.9	0.92	575	7.0	1138	1.0	3.10	
400	M2CA 400 MLA	3GCA 401 410-••A	2982	96.6	96.5	0.92	655	7.6	1281	0.8	3.00	
450 <sup>1)</sup>	M2CA 400 MLB	3GCA 401 420-••A	2980	96.6	96.5	0.92	730	7.4	1442	0.8	3.00	
500 <sup>1)</sup>	M2CA 400 LKA	3GCA 401 510-••A	2984	96.6	96.5	0.91	815	7.2	1600	0.7	3.40	
560 <sup>1)</sup>	M2CA 400 LKB	3GCA 401 520-••A	2983	96.7	96.6	0.92	910	7.3	1792	0.7	3.40	
<b>3000 r/min = 2-poles</b>			<b>400 V 50 Hz</b>				<b>High-output design</b>					
110	M2CA 280 MB	3GCA 281 320-••A	2977	95.8	95.5	0.90	184	7.9	353	2.4	3.0	
132	M2CA 280 MC	3GCA 281 330-••A	2976	96.0	95.7	0.91	222	7.7	424	2.6	3.0	
160	M2CA 280 MD	3GCA 281 340-••A	2975	96.0	95.7	0.91	266	7.9	514	2.8	3.1	
250 <sup>2)</sup>	M2CA 315 LB	3GCA 311 520-••A	2980	96.5	96.2	0.90	420	8.1	801	2.8	2.9	
315 <sup>2)</sup>	M2CA 315 LC	3GCA 311 530-••A	2982	96.8	96.6	0.90	528	8.9	1009	3.4	3.1	
<b>1500 r/min = 4-poles</b>			<b>400 V 50 Hz</b>				<b>Basic design</b>					
75	M2CA 280 SA	3GCA 282 110-••A	1483	95.0	94.9	0.84	137	6.8	483	2.4	2.8	
90	M2CA 280 SMA	3GCA 282 210-••A	1484	95.2	95.1	0.85	163	7.1	579	2.7	2.9	
110	M2CA 315 SA	3GCA 312 110-••A	1487	95.4	95.1	0.85	198	6.9	706	2.1	2.8	
132	M2CA 315 SMA	3GCA 312 210-••A	1486	95.6	95.5	0.85	238	6.7	848	2.2	2.7	
160 <sup>2)</sup>	M2CA 315 MB	3GCA 312 320-••A	1486	96.0	95.9	0.86	282	7.2	1028	2.4	2.9	
200 <sup>2)</sup>	M2CA 315 LA	3GCA 312 510-••A	1486	96.2	96.2	0.86	351	7.2	1285	2.5	2.9	
200	M2CA 355 SA	3GCA 352 110-••A	1487	95.8	95.6	0.87	345	7.0	1284	2.1	2.7	
250	M2CA 355 MA	3GCA 352 310-••A	1487	96.5	96.4	0.87	430	7.2	1605	2.3	2.8	
315	M2CA 355 LA	3GCA 352 510-••A	1488	96.5	96.4	0.87	545	7.4	2021	2.4	2.8	
355	M2CA 355 LB	3GCA 352 520-••A	1489	96.5	96.4	0.88	605	7.2	2276	1.4	3.0	
400 <sup>1)</sup>	M2CA 355 LKD	3GCA 352 540-••A	1489	96.7	96.5	0.88	680	7.5	2565	1.5	3.0	
450	M2CA 400 MLA	3GCA 402 410-••A	1489	96.7	96.6	0.90	740	6.9	2886	1.2	2.8	
500	M2CA 400 MLB	3GCA 402 420-••A	1489	96.8	96.7	0.89	830	7.3	3206	1.3	2.9	
560	M2CA 400 LKA	3GCA 402 510-••A	1489	96.9	96.8	0.90	925	6.6	3591	1.1	2.6	
630 <sup>1)</sup>	M2CA 400 LKB	3GCA 402 520-••A	1489	96.9	96.8	0.87	1080	6.9	4040	1.2	2.8	
<b>1500 r/min = 4-poles</b>			<b>400 V 50 Hz</b>				<b>High-output design</b>					
110	M2CA 280 MB	3GCA 282 320-••A	1483	95.3	95.2	0.86	195	7.5	708	2.7	2.8	
132	M2CA 280 MC	3GCA 282 330-••A	1483	95.6	95.5	0.86	235	7.1	850	2.8	2.9	
160	M2CA 280 MD	3GCA 282 340-••A	1483	95.8	95.7	0.86	283	7.1	1030	2.8	3.1	
250	M2CA 315 LB	3GCA 312 520-••A	1487	96.1	96.0	0.85	445	7.4	1605	2.5	2.9	
315 <sup>2)</sup>	M2CA 315 LC	3GCA 312 530-••A	1487	96.4	96.2	0.85	560	7.8	2023	2.6	3.2	

<sup>1)</sup> Temperature rise class F.  
<sup>2)</sup> Temperature rise class F for 380 V.

The two bullets in the product code indicate choice of mounting arrangement, voltage and frequency (see ordering information page).

# General purpose steel motors

## Technical data for totally enclosed squirrel cage three phase motors

IP 55 – IC 411 – Insulation class F, temperature rise class B

Output kW	Motor type	Speed r/min	Effi- ciency %	Power factor cos φ 100%	Current I <sub>N</sub> A	Speed r/min	Effi- ciency %	Power factor cos φ 100%	Current I <sub>N</sub> A	Moment of inertia J = ¼ GD <sup>2</sup> kgm <sup>2</sup>	Weight kg	Sound pressure level L <sub>p</sub> dB(A)	
<b>3000 r/min = 2-poles</b>		<b>380 V 50 Hz</b>				<b>415 V 50 Hz</b>				<b>Basic design</b>			
75	M2CA 280 SA	2974	94.8	0.89	137	2980	94.8	0.87	127	0.8	480	77	
90	M2CA 280 SMA	2970	95.1	0.90	159	2978	95.1	0.89	147	0.9	545	77	
110	M2CA 315 SA	2980	95.1	0.87	202	2983	0.0	0.85	190	1.2	695	80	
132	M2CA 315 SMA	2980	95.4	0.89	238	2983	95.7	0.87	222	1.4	770	80	
160	M2CA 315 MB	2979	96.1	0.90	282	2982	96.1	0.89	262	1.7	840	80	
200	M2CA 355 SA	2975	95.4	0.92	350	2979	95.5	0.91	325	3.2	1220	83	
200	M2CA 315 LA	2977	96.3	0.90	350	2981	96.3	0.90	321	2.1	975	80	
250	M2CA 355 MA	2978	96.0	0.92	430	2982	96.1	0.92	395	3.8	1320	83	
280	M2CA 355 MB	2975	96.0	0.92	495	2980	96.1	0.92	450	3.8	1320	83	
315	M2CA 355 LA	2976	96.5	0.93	540	2982	96.6	0.92	495	4.8	1530	83	
355	M2CA 355 LB	2972	96.0	0.92	605	2974	96.1	0.92	550	4.8	1550	83	
400	M2CA 400 MLA	2980	96.5	0.92	680	2983	96.5	0.92	630	7.2	2300	85	
450	<sup>1)</sup> M2CA 400 MLB	2978	96.6	0.92	770	2982	96.6	0.92	700	7.2	2300	85	
500	<sup>1)</sup> M2CA 400 LKA	2982	96.6	0.92	850	2985	96.6	0.91	790	8.5	2700	85	
560	<sup>1)</sup> M2CA 400 LKB	2981	96.7	0.92	965	2984	96.8	0.91	885	8.5	2700	85	
<b>3000 r/min = 2-poles</b>		<b>380 V 50 Hz</b>				<b>415 V 50 Hz</b>				<b>High-output design</b>			
110	M2CA 280 MB	2974	95.7	0.91	193	2979	95.8	0.90	179	1.15	580	77	
132	M2CA 280 MC	2972	95.9	0.91	233	2978	96.0	0.90	213	1.4	755	77	
160	M2CA 280 MD	2971	95.9	0.91	280	2977	96.0	0.90	255	1.55	810	77	
250	<sup>2)</sup> M2CA 315 LB	2977	96.4	0.90	442	2982	96.5	0.89	404	2.65	1230	80	
315	<sup>2)</sup> M2CA 315 LC	2979	96.8	0.90	550	2983	96.8	0.90	508	3.3	1410	80	
<b>1500 r/min = 4-poles</b>		<b>380 V 50 Hz</b>				<b>415 V 50 Hz</b>				<b>Basic design</b>			
75	M2CA 280 SA	1481	94.8	0.86	142	1485	95.0	0.82	134	1.15	445	68	
90	M2CA 280 SMA	1482	95.1	0.86	169	1486	95.2	0.83	159	1.4	490	68	
110	M2CA 315 SA	1486	95.3	0.86	204	1488	95.3	0.83	198	2	675	71	
132	M2CA 315 SMA	1485	95.5	0.86	245	1487	95.5	0.84	232	2.3	730	71	
160	M2CA 315 MB	1485	95.9	0.87	294	1487	96.0	0.85	277	2.9	850	71	
200	M2CA 315 LA	1484	96.1	0.87	365	1487	96.2	0.85	342	3.5	970	71	
200	M2CA 355 SA	1485	95.7	0.87	360	1488	95.8	0.86	340	5.5	1220	80	
250	M2CA 355 MA	1486	96.4	0.87	455	1488	96.5	0.86	420	6.5	1350	80	
315	M2CA 355 LA	1486	96.4	0.87	570	1489	96.5	0.86	530	7.8	1550	80	
355	M2CA 355 LB	1487	96.4	0.89	630	1490	96.5	0.87	590	7.8	1550	80	
400	<sup>1)</sup> M2CA 355 LKD	1487	96.6	0.89	710	1490	96.7	0.87	660	10	1900	85	
450	M2CA 400 MLA	1487	96.6	0.90	770	1490	96.7	0.90	720	13	2400	85	
500	M2CA 400 MLB	1488	96.7	0.90	870	1490	96.8	0.89	800	13	2400	85	
560	M2CA 400 LKA	1487	96.8	0.91	965	1490	96.9	0.90	890	14	2700	85	
630	<sup>1)</sup> M2CA 400 LKB	1488	96.8	0.88	1125	1490	96.9	0.87	1040	15	2800	85	
<b>1500 r/min = 4-poles</b>		<b>380 V 50 Hz</b>				<b>415 V 50 Hz</b>				<b>High-output design</b>			
110	M2CA 280 MB	1481	95.2	0.87	204	1486	95.5	0.84	193	1.7	550	68	
132	M2CA 280 MC	1481	95.4	0.87	245	1485	95.7	0.85	227	2.3	775	70	
160	M2CA 280 MD	1482	95.6	0.87	295	1485	95.8	0.85	276	2.5	820	70	
250	M2CA 315 LB	1485	95.9	0.86	463	1488	96.2	0.84	434	4.4	1200	78	
315	<sup>2)</sup> M2CA 315 LC	1485	96.1	0.86	582	1489	96.4	0.84	548	5.5	1380	78	

# General purpose steel motors

## Technical data for totally enclosed squirrel cage three phase motors

IP 55 – IC 411 – Insulation class F, temperature rise class B

Output kW	Motor type	Product code	Speed r/min	Efficiency		Power factor cos φ	Current		Torque			
				Full load 100%	3/4 load 75%		I <sub>N</sub> A	I <sub>s</sub> A	T <sub>N</sub> Nm	T <sub>s</sub> Nm	T <sub>max</sub> Nm	
<b>1000 r/min = 6-poles</b>			<b>400 V 50 Hz</b>				<b>Basic design</b>					
45	M2CA 280 SA	3GCA 283 110-••A	990	94.1	94.0	0.82	85	6.6	434	2.5	2.5	
55	M2CA 280 SMA	3GCA 283 210-••A	989	94.4	94.3	0.83	102	6.6	531	2.5	2.5	
75	M2CA 315 SA	3GCA 313 110-••A	992	94.9	94.7	0.80	143	7.1	722	2.3	2.7	
90	M2CA 315 SMA	3GCA 313 210-••A	991	95.3	95.2	0.83	165	7.1	867	2.3	2.7	
110	M2CA 315 MB	3GCA 313 320-••A	991	95.3	95.1	0.83	201	7.3	1060	2.5	2.8	
132	M2CA 355 SA	3GCA 353 110-••A	992	95.3	95.1	0.85	235	6.8	1270	1.7	2.6	
132	M2CA 315 LA	3GCA 313 510-••A	990	95.4	95.3	0.84	241	6.7	1273	2.4	2.7	
160	M2CA 355 SB	3GCA 353 120-••A	992	95.9	95.7	0.85	280	6.8	1540	1.8	2.7	
200	M2CA 355 MA	3GCA 353 310-••A	993	95.9	95.7	0.85	350	7.5	1923	2.0	2.8	
250 <sup>1)</sup>	M2CA 355 MB	3GCA 353 320-••A	991	95.9	95.8	0.80	475	7.3	2409	2.2	3.0	
315	M2CA 355 LKD	3GCA 353 540-••A	991	96.2	96.1	0.84	565	7.3	3035	2.0	3.0	
355	M2CA 400 MLA	3GCA 403 410-••A	992	96.4	96.3	0.85	625	6.4	3417	1.2	2.7	
400 <sup>1)</sup>	M2CA 400 MLB	3GCA 403 420-••A	992	96.5	96.4	0.85	700	6.4	3850	1.2	2.7	
450	M2CA 400 LKA	3GCA 403 510-••A	993	96.5	96.4	0.85	790	6.8	4327	1.3	2.8	
500 <sup>1)</sup>	M2CA 400 LKB	3GCA 403 520-••A	992	96.5	96.4	0.85	880	6.8	4813	1.3	2.8	
<b>1000 r/min = 6-poles</b>			<b>400 V 50 Hz</b>				<b>High-output design</b>					
75	M2CA 280 MB	3GCA 283 320-••A	990	94.5	94.4	0.83	139	7.3	723	2.8	2.7	
90	M2CA 280 MC	3GCA 283 330-••A	989	94.9	94.8	0.83	168	7.4	869	2.9	2.9	
110	M2CA 280 MD	3GCA 283 340-••A	990	95.2	95.1	0.83	202	7.9	1061	3.1	3.0	
160 <sup>2)</sup>	M2CA 315 LB	3GCA 313 520-••A	991	95.6	95.4	0.83	292	7.7	1542	2.9	3.1	
200 <sup>2)</sup>	M2CA 315 LC	3GCA 313 530-••A	991	95.8	95.7	0.83	364	7.4	1927	2.8	2.9	
<b>750 r/min = 8-poles</b>			<b>400 V 50 Hz</b>				<b>Basic design</b>					
37	M2CA 280 SA	3GCA 284 110-••A	741	93.4	93.1	0.78	74	7.3	477	1.8	3.1	
45	M2CA 280 SMA	3GCA 284 210-••A	741	94.0	93.8	0.78	90	7.6	580	1.9	3.2	
55	M2CA 315 SA	3GCA 314 110-••A	741	94.0	93.7	0.80	107	7.1	710	1.8	2.8	
75	M2CA 315 SMA	3GCA 314 210-••A	740	94.5	94.2	0.81	142	7.1	968	1.8	2.8	
90	M2CA 315 MB	3GCA 314 320-••A	740	94.7	94.5	0.82	169	7.3	1161	1.9	2.8	
110 <sup>2)</sup>	M2CA 315 LA	3GCA 314 510-••A	740	94.8	94.7	0.83	202	7.0	1420	1.9	2.7	
110	M2CA 355 SA	3GCA 354 110-••A	742	94.6	94.0	0.80	215	5.6	1415	1.4	2.2	
132	M2CA 355 MA	3GCA 354 310-••A	743	95.0	94.5	0.77	265	5.8	1696	1.5	2.3	
160	M2CA 355 MB	3GCA 354 320-••A	742	95.2	94.8	0.79	310	6.4	2059	1.8	2.5	
200	M2CA 355 LKD	3GCA 354 540-••A	743	95.5	95.1	0.74	414	6.6	2570	1.8	2.7	
250	M2CA 400 MLA	3GCA 404 410-••A	744	96.0	95.7	0.77	490	7.2	3209	1.6	2.9	
315 <sup>1)</sup>	M2CA 400 LKA	3GCA 404 510-••A	744	96.2	95.9	0.79	605	6.9	4043	1.5	2.8	
<b>750 r/min = 8-poles</b>			<b>400 V 50 Hz</b>				<b>High-output design</b>					
55	M2CA 280 MB	3GCA 284 320-••A	741	94.4	94.2	0.79	108	7.8	709	1.9	3.2	

<sup>1)</sup> Temperature rise acc. to class F.

<sup>2)</sup> Temperature rise acc. to class F by 380 V.

The two bullets in the product code indicate choice of mounting arrangement, voltage and frequency (see ordering information page).

# General purpose steel motors

## Technical data for totally enclosed squirrel cage three phase motors

IP 55 – IC 411 – Insulation class F, temperature rise class B

Output kW	Motor type	Speed r/min	Effi- ciency %	Power factor cos φ 100%	Current I <sub>N</sub> A	Speed r/min	Effi- ciency %	Power factor cos φ 100%	Current I <sub>N</sub> A	Moment of inertia J = ¼ GD <sup>2</sup> kgm <sup>2</sup>	Weight kg	Sound pressure level L <sub>p</sub> dB(A)	
<b>1000 r/min = 6-poles</b>		<b>380 V 50 Hz</b>				<b>415 V 50 Hz</b>				<b>Basic design</b>			
45	M2CA 280 SA	988	94.0	0.83	89	991	94.2	0.81	82	1.65	440	66	
55	M2CA 280 SMA	988	94.3	0.84	106	991	94.4	0.82	99	2	475	66	
75	M2CA 315 SA	991	94.8	0.82	146	993	94.9	0.77	143	2.9	630	72	
90	M2CA 315 SMA	990	95.2	0.84	173	992	95.3	0.82	162	3.8	720	72	
110	M2CA 315 MB	990	95.1	0.84	212	992	95.3	0.82	198	4.5	805	75	
132	M2CA 355 SA	991	95.2	0.86	245	993	95.3	0.84	230	8.7	1200	75	
132	M2CA 315 LA	988	95.3	0.84	252	991	95.5	0.83	234	5.4	910	75	
160	M2CA 355 SB	991	95.8	0.86	295	993	95.9	0.84	275	10	1320	75	
200	M2CA 355 MA	992	95.8	0.86	370	993	95.9	0.84	350	13	1550	75	
250	<sup>1)</sup> M2CA 355 MB	990	95.8	0.82	485	992	95.9	0.78	470	13	1550	75	
315	M2CA 355 LKD	990	96.2	0.85	590	992	96.2	0.82	560	15	1900	82	
355	M2CA 400 MLA	991	96.3	0.86	650	993	96.4	0.84	610	17	2400	82	
400	<sup>1)</sup> M2CA 400 MLB	991	96.3	0.86	730	992	96.4	0.84	680	17	2400	82	
450	M2CA 400 LKA	992	96.5	0.86	825	993	96.5	0.83	790	19	2700	82	
500	<sup>1)</sup> M2CA 400 LKB	991	96.5	0.86	920	993	96.5	0.83	870	19	2700	82	
<b>1000 r/min = 6-poles</b>		<b>380 V 50 Hz</b>				<b>415 V 50 Hz</b>				<b>High-output design</b>			
75	M2CA 280 MB	988	94.5	0.84	144	991	94.5	0.81	137	2.6	545	67	
90	M2CA 280 MC	988	94.8	0.84	174	990	94.9	0.81	164	3.1	815	67	
110	M2CA 280 MD	988	95.1	0.84	210	991	95.2	0.81	200	4.1	835	67	
160	<sup>2)</sup> M2CA 315 LB	990	95.5	0.84	304	992	95.6	0.82	287	7.3	1200	80	
200	<sup>2)</sup> M2CA 315 LC	989	95.7	0.84	381	992	95.8	0.82	354	9.2	1380	80	
<b>750 r/min = 8-poles</b>		<b>380 V 50 Hz</b>				<b>415 V 50 Hz</b>				<b>Basic design</b>			
37	M2CA 280 SA	740	93.2	0.80	75	742	93.4	0.76	73	1.85	460	65	
45	M2CA 280 SMA	740	93.8	0.80	92	742	94.0	0.75	90	2.2	500	65	
55	M2CA 315 SA	740	93.9	0.82	108	742	94.0	0.78	105	2.9	630	70	
75	M2CA 315 SMA	739	94.3	0.82	148	741	94.3	0.79	138	3.8	715	70	
90	M2CA 315 MB	739	94.6	0.83	175	741	94.6	0.80	165	4.5	800	77	
110	<sup>2)</sup> M2CA 315 LA	738	94.7	0.84	213	740	94.8	0.81	198	5.4	900	77	
110	M2CA 355 SA	740	94.5	0.80	220	742	94.7	0.79	205	8.7	1200	75	
132	M2CA 355 MA	742	94.8	0.78	270	744	95.0	0.75	260	10	1350	75	
160	M2CA 355 MB	741	95.1	0.80	320	743	95.2	0.78	300	13	1550	75	
200	M2CA 355 LKD	742	95.5	0.76	423	744	95.5	0.72	410	15	1900	80	
250	M2CA 400 MLA	743	96.0	0.79	500	745	96.0	0.75	480	17	2400	80	
315	<sup>1)</sup> M2CA 400 LKA	743	96.1	0.80	620	745	96.2	0.76	600	19	2700	80	
<b>750 r/min = 8-poles</b>		<b>380 V 50 Hz</b>				<b>415 V 50 Hz</b>				<b>High-output design</b>			
55	M2CA 280 MB	740	94.2	0.81	110	742	94.4	0.77	106	2.85	575	65	

# General purpose steel motors

## Technical data for totally enclosed squirrel cage three phase motors, two-speed

IP 55 – IC 411 – Insulation class F, temperature rise class F

Output kW	Motor type	Product code	Speed r/min	Efficiency %	Power factor cos φ	Current		Torque			Moment of inertia $J = \frac{1}{4} GD^2$ kgm <sup>2</sup>	Weight kg
						$I_N$ A	$I_s$ A	$T_N$ Nm	$T_s$ Nm	$T_{max}$ Nm		
<b>1500/1000 r/min = 4/6 poles</b>			<b>400 V 50 Hz</b>			<b>Fan drive, two separate windings</b>						
60/18.5	M2CA 280 SA	3GCA 288 114-••A	1487/991	93.5/88.0	0.82/0.76	113/40	7.7/7.4	385/178	2.3/2.9	3.0/2.6	1.15	445
77/25	M2CA 280 SMA	3GCA 288 214-••A	1486/991	93.9/89.3	0.83/0.76	144/54	7.6/7.7	495/241	2.4/3.2	2.9/2.7	1.4	490
90/28	M2CA 280 MB	3GCA 288 324-••A	1485/991	94.2/89.8	0.86/0.78	161/58	7.4/7.7	579/270	2.3/3.2	2.7/2.8	1.7	550
110/32	M2CA 315 SMA	3GCA 318 214-••A	1489/992	95.2/91.2	0.85/0.78	199/67	6.6/6.5	706/308	1.9/2.8	2.6/2.9	2.3	730
125/37	M2CA 315 MB	3GCA 318 324-••A	1488/992	95.5/92.2	0.86/0.79	219/75	6.6/6.4	802/356	1.9/2.9	2.4/2.8	2.9	850
150/44	M2CA 315 LA	3GCA 318 514-••A	1488/991	95.7/92.6	0.87/0.79	260/88	6.6/6.4	963/424	1.9/3.0	2.4/2.7	3.5	970
180/55	M2CA 355 MA	3GCA 358 314-••A	1483/986	95.0/91.2	0.90/0.85	300/100	5.3/5.0	1159/532	1.1/1.3	2.3/2.2	6.5	1350
260/85	M2CA 355 LA	3GCA 358 514-••A	1487/988	95.7/92.0	0.90/0.85	435/155	7.7/5.9	1670/821	1.7/1.6	3.2/2.4	7.8	1550
<b>1500/750 r/min = 4 - 8 poles</b>			<b>400 V 50 Hz</b>			<b>Fan drive, Dahlander-connection</b>						
65/15	M2CA 280 SA	3GCA 288 119-••A	1484/743	93.2/90.0	0.84/0.63	121/38	7.5/5.3	418/193	2.7/2.8	2.9/2.3	1.15	445
80/20	M2CA 280 SMA	3GCA 288 219-••A	1486/743	93.8/91.5	0.83/0.63	150/50	8.5/5.4	514/257	3.3/2.9	3.4/2.6	1.4	490
90/23	M2CA 280 MB	3GCA 288 329-••A	1486/742	94.1/91.8	0.85/0.64	164/56	8.8/5.4	578/296	3.6/2.8	3.5/2.6	1.7	550
110/22	M2CA 315 SMA	3GCA 318 219-••A	1487/744	94.6/92.5	0.85/0.62	197/56	6.8/4.9	706/282	1.9/2.1	2.6/2.5	2.3	730
132/26	M2CA 315 MB	3GCA 318 329-••A	1486/746	94.9/93.0	0.86/0.64	235/65	6.8/4.8	848/334	2.0/2.0	2.6/2.4	2.9	850
160/32	M2CA 315 LA	3GCA 318 519-••A	1486/743	95.2/93.4	0.86/0.64	283/80	7.0/4.8	1028/411	2.1/2.1	2.7/2.5	3.5	970
200/40	M2CA 355 MA	3GCA 358 319-••A	1489/745	95.3/93.7	0.90/0.68	340/90	6.8/4.8	1282/512	1.4/1.3	2.8/2.5	6.5	1350
250/50	M2CA 355 LA	3GCA 358 519-••A	1490/745	95.5/94.0	0.87/0.64	435/120	7.5/5.1	1602/641	1.5/1.4	3.2/2.6	7.8	1550
<b>1500/1000 r/min = 4/6 poles</b>			<b>400 V 50 Hz</b>			<b>Constant torque, two separate windings</b>						
50/32	M2CA 280 SA	3GCA 289 114-••A	1486/987	92.0/90.5	0.84/0.78	94/65	6.9/6.2	321/310	2.0/2.5	2.6/2.2	1.15	445
60/40	M2CA 280 SMA	3GCA 289 214-••A	1486/987	92.6/91.8	0.85/0.78	111/82	7.1/6.6	386/387	2.1/2.8	2.7/2.3	1.4	490
70/47	M2CA 280 MB	3GCA 289 324-••A	1488/989	93.2/92.6	0.84/0.77	131/96	8.0/7.4	450/454	2.6/3.4	3.1/2.5	1.7	550
90/60	M2CA 315 SMA	3GCA 319 214-••A	1488/990	94.3/93.5	0.86/0.77	161/121	5.9/5.8	577/579	1.5/2.6	2.3/2.4	2.3	730
110/75	M2CA 315 MB	3GCA 319 324-••A	1490/989	94.9/93.9	0.86/0.79	195/147	6.8/5.6	705/724	1.9/2.7	2.6/2.3	2.9	850
132/90	M2CA 315 LA	3GCA 319 514-••A	1489/990	95.1/94.1	0.85/0.76	238/181	6.7/6.0	847/868	1.9/3.1	2.7/2.7	3.5	970
160/110	M2CA 315 LB	3GCA 319 524-••A	1491/990	95.3/94.5	0.85/0.79	287/213	7.2/5.8	1025/1061	2.1/2.8	2.7/2.3	3.9	1000
180/120	M2CA 355 MA	3GCA 359 314-••A	1488/990	95.0/94.3	0.89/0.80	305/230	7.2/7.3	1155/1157	1.4/2.0	3.1/3.1	6.5	1350
230/150	M2CA 355 LA	3GCA 359 514-••A	1489/990	95.3/94.5	0.89/0.82	395/280	7.7/6.9	1475/1447	1.5/2.0	3.2/2.9	7.8	1550
<b>1500/750 r/min = 4 - 8 poles</b>			<b>400 V 50 Hz</b>			<b>Constant torque, Dahlander-connection</b>						
50/32	M2CA 280 SA	3GCA 289 119-••A	1486/743	92.7/91.8	0.88/0.70	89/72	7.2/6.9	321/411	1.9/2.7	2.6/2.5	1.85	460
65/40	M2CA 280 SMA	3GCA 289 219-••A	1486/743	93.1/92.0	0.88/0.69	115/92	7.7/7.2	418/514	2.1/3.1	2.7/2.7	2.2	500
85/50	M2CA 280 MB	3GCA 289 329-••A	1487/743	93.8/92.8	0.88/0.68	149/115	8.5/7.7	546/643	2.5/3.4	2.9/2.9	2.85	575
100/65	M2CA 315 SMA	3GCA 319 219-••A	1487/742	94.2/93.8	0.89/0.74	174/137	6.5/6.3	642/836	1.5/2.1	2.6/2.5	4.1	755
120/75	M2CA 315 MB	3GCA 319 329-••A	1486/742	94.5/94.1	0.90/0.74	204/155	7.0/6.5	739/965	1.7/2.2	2.6/2.6	4.9	845
150/95	M2CA 315 LA	3GCA 319 519-••A	1486/742	94.7/94.2	0.89/0.72	262/204	7.2/6.5	964/1223	2.0/2.4	2.8/2.6	5.8	950
150/100	M2CA 355 MA	3GCA 359 319-••A	1487/741	94.7/94.3	0.90/0.72	255/210	5.6/4.4	963/1288	1.2/1.2	2.5/2.2	6.5	1350
180/130	M2CA 355 LA	3GCA 359 519-••A	1488/742	95.2/94.6	0.90/0.72	305/275	6.6/4.5	1155/1673	1.4/1.3	2.8/2.2	7.8	1550

The two bullets in the product code indicate choice of mounting arrangement, voltage and frequency (see ordering information page).



# General purpose steel motors - Variant codes

Code 1)	Variant	Motor size			
		280	315	355	400
<b>Balancing</b>					
052	Vibration acc. to Grade A (IEC 60034-14).	P	P	P	P
417	Vibration acc. to Grade B (IEC 60034-14).	P	P	P	P
423	Balanced without key.	R	R	R	R
424	Full key balancing.	P	P	P	P
<b>Bearings and lubrication</b>					
036	Transport lock for bearings.	M	M	M	M
037	Roller bearing at D-end.	M	M	M	R
039	Cold resistant grease. For bearing temperatures -55 - +100°C.	M	M	M	M
040	Heat resistant grease (-25°... +150°C).	M	M	M	M
043	SPM-nipples.	M	M	M	M
058	Angular contact bearing at D-end, shaft force away from bearing.	P	P	P	P
060	Angular contact bearing at D-end, shaft force towards bearing.	P	P	P	P
107	Bearing mounted PT100 resistance elements.	P	P	P	P
420	Bearing mounted PTC thermistors.	P	P	P	P
796	Grease nipples JIS B 1575 PT 1/8 Type A. Stainless steel.	M	M	M	M
<b>Branch standard designs</b>					
071	Cooling tower duty. Only motors with shaft extensions downwards.	R	R	R	R
142	"Manilla"-winding connection, (440 VD series, 220 VD parallel, 60 Hz).	P	P	P	P
178	Stainless steel/acid proof bolts.	P	P	P	P
209	Non-standard voltage or frequency (special winding).	P	P	P	P
425	Corrosion protected stator and rotor core.	P	P	P	P
<b>Cooling system</b>					
044	Unidirectional fan, clockwise seen from D-end.	P	P	P	P
045	Unidirectional fan, counter clockwise seen from D-end.	P	P	P	P
068	Metal fan.	M	M	M	M
075	Cooling method IC 418 (without fan).	P	P	P	P
<b>Coupling</b>					
035	Assembly of customer supplied coupling-half (finish bored and balanced).	M	M	M	M
<b>Dimension drawing</b>					
141	Binding dimension drawing.	M	M	M	M
<b>Drain holes</b>					
065	Plugged drain holes.	M	M	M	M
066	Modified drain hole position (for specified IM xxxx).	M	M	M	M
<b>Earthing bolt</b>					
067	External earthing bolt.	M	M	M	M

1) Certain variant codes cannot be used simultaneously.

**S** = Included as standard  
**M** = On modification of a stocked motor,  
or on new manufacture,  
the number per order may be limited.

**P** = New manufacture only.  
**R** = On request.  
**NA** = Not applicable

Code 1)	Variant	Motor size			
		280	315	355	400
<b>Heating elements</b>					
	<b>Motor size</b>	<b>Element capacity:</b>			
	280	50 W			
	315	65 W			
	355-400	2 x 65 W			
450	Heating element, 100-120 V.	P	P	P	P
451	Heating element, 200-240 V.	M	M	M	M
<b>Mounting arrangements</b>					
009	IM 2001 foot/flange mounted, IEC flange, from IM 1001 (B35 from B3).	M	M	M	M
<b>Painting</b>					
114	Special paint colour, standard grade.	M	M	M	M
179	Special paint specification.	P	P	P	P
<b>Protection</b>					
005	Protective roof, vertical motor, shaft down.	M	M	M	M
072	Radial seal at D-end.	M	M	M	M
073	Sealed against oil at D-end.	P	P	P	P
158	Degree of protection IP 65. Dust proof version.	M	M	M	M
403	Degree of protection IP 56.	M	M	M	M
<b>Rating &amp; instruction plates</b>					
002	Restamping voltage, frequency and output, continuous duty.	M	M	M	M
095	Restamping output (maintained voltage, frequency), intermittent duty.	M	M	M	M
135	Mounting of additional identification plate, stainless.	M	M	M	M
138	Mounting of additional identification plate, aluminum.	M	M	M	M
161	Additional rating plate delivered loose.	M	M	M	M
<b>Shaft &amp; rotor</b>					
069	Two shaft extensions as per basic catalogue. Standard shaft material.	P	P	P	P
070	One or two special shaft extensions, standard shaft material.	P	P	P	P
410	Stainless/acid-proof steel shaft (standard or non-standard design). One or two extensions.				
<b>Standards and regulations</b>					
010	Fulfilling CSA requirements.	P	P	P	P
011	Fulfilling CSA Energy Efficiency Verification (010 included).	R	R	R	R
<b>Stator winding temperature sensors</b>					
121	Bimetal detectors, break type (NCC), (3 in series), 130°C, in stator winding.	M	M	M	M
122	Bimetal detectors, break type (NCC), (3 in series), 150°C, in stator winding.	M	M	M	M
123	Bimetal detectors, break type (NCC), (3 in series), 170°C, in stator winding.	M	M	M	M
125	Bimetal detectors, break type (NCC), (2x3 in series), 150°C, in stator winding.	M	M	M	M
127	Bimetal detectors, break type (NCC), (3 in series, 130°C & 3 in series, 150°C), in stator winding.				
435	PTC - thermistors (3 in series), 130°C, in stator winding.	M	M	M	M
436	PTC - thermistors (3 in series), 150°C, in stator winding.	S	S	S	S
437	PTC - thermistors (3 in series), 170°C, in stator winding.	M	M	M	M
439	PTC - thermistors (2x3 in series), 150°C, in stator winding.	M	M	M	M

1) Certain variant codes cannot be used simultaneously.

**S** = Included as standard  
**M** = On modification of a stocked motor,  
or on new manufacture,  
the number per order may be limited.

**P** = New manufacture only.  
**R** = On request.  
**NA** = Not applicable

Code 1)	Variant	Motor size			
		280	315	355	400
440	PTC - thermistors (3 in series, 110°C & 3 in series, 130°C), in stator winding.	R	R	R	R
441	PTC - thermistors (3 in series 130°C & 3 in series 150°C), in stator winding.	M	M	M	M
442	PTC - thermistors (3 in series 150°C & 3 in series 170°C), in stator winding.	M	M	M	M
446	PT100 resistance elements (2 per phase) in stator winding.	M	M	M	M
446	PT100 resistance elements (2 per phase) in stator winding.	M	M	M	M
<b>Terminal box</b>					
015	Motor supplied in D-connection.	M	M	M	M
017	Motor supplied in Y-connection.	M	M	M	M
019	Larger than standard terminal box.	R	R	R	R
136	Extended cable connection, standard terminal box.	R	R	R	R
137	Extended cable connection, low terminal box.	P	P	R	R
157	Terminal box degree of protection IP 65.	M	M	M	M
187	Cable glands of non-standard design.	R	R	R	R
413	Extended cable connection, no terminal box.	P	P	P	R
414	Smaller than standard terminal box.	P	P	P	P
418	Separate terminal box for temperature detectors.	P	P	P	P
468	Non-standard cable entry direction (please state direction).	M	M	M	M
469	Axial cable entry direction, terminal box 4x90° turnable.	P	P	P	P
<b>Testing</b>					
145	Type test report from catalogue motor, 400 V 50 Hz.	M	M	M	M
146	Type test with report for motor from specific delivery batch.	P	P	P	P
147	Type test with report for motor from specific delivery batch, customer witnessed.	P	P	P	P
148	Routine test report.	M	M	M	M
149	Testing according to separate test specification.	R	R	R	R
221	Type test and multi-point load test with report for motor from specific delivery batch.	R	R	R	R
222	Torque/speed curve, type test and multi-point load test with report for motor from specific delivery batch.	P	P	P	P
760	Vibration level test.	P	P	P	P
761	Vibration spectrum test.	P	P	P	P
762	Noise level test.	P	P	P	P
763	Noise spectrum test.	P	P	P	P
<b>Y/D-starting</b>					
117	Terminals for Y/D start at both speeds (two speed windings).	P	P	P	P
118	Terminals for Y/D start at high speed (two speed windings).	P	P	P	P
119	Terminals for Y/D start at low speed (two speed windings).	P	P	P	P

1) Certain variant codes cannot be used simultaneously.

**S** = Included as standard  
**M** = On modification of a stocked motor,  
or on new manufacture,  
the number per order may be limited.

**P** = New manufacture only.  
**R** = On request.  
**NA** = Not applicable

# General purpose steel motors

# Sizes 280-315

## Dimension drawings

Foot-mounted; IM B3 (IM 1001), IM B6 (IM 1051), IM B7 (IM 1061), IM B8 (IM 1071), IM V5 (IM 1011), IM V6 (IM 1031) – terminal box top mounted

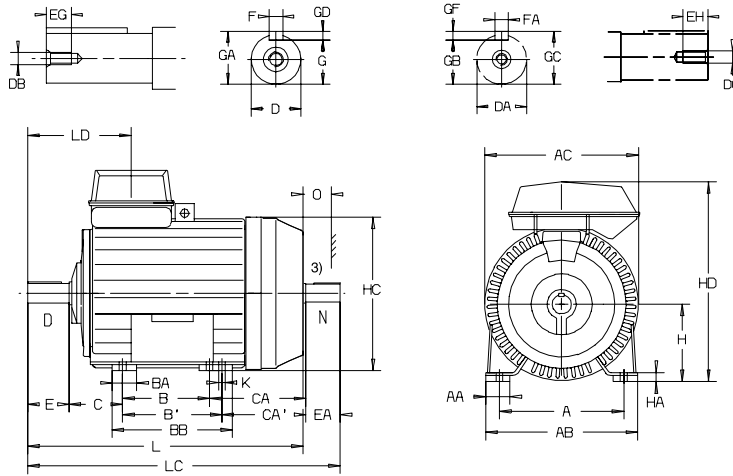

3

Motor size	Poles <sup>1)</sup>	A	AA	AB	AC	B	B'	BA	BB	C	CA	CA'	D	DA	DB	DC	E	EA	EG	EH
280 SA	2	457	80	545	555	368	–	100	501	190	372	–	65	60	M20	M20	140	140	40	40
	4-8	457	80	545	555	368	–	100	450	190	302	–	75	65	M20	M20	140	140	40	40
280 SMA	2	457	80	545	555	368	419	100	501	190	372	321	65	60	M20	M20	140	140	40	40
	4-8	457	80	545	555	368	419	100	501	190	372	321	75	65	M20	M20	140	140	40	40
280 MB	2	457	80	545	555	419	–	100	501	190	381	–	65	60	M20	M20	140	140	40	40
	4-8	457	80	545	555	419	–	100	501	190	381	–	75	65	M20	M20	140	140	40	40
280 MC,MD	2	457	80	545	555	419	–	100	501	190	381	–	65	60	M20	M20	140	140	40	40
	4-8	457	80	545	555	419	–	100	501	190	381	–	75	65	M20	M20	140	140	40	40
315 SA	2	508	100	622	624	406	–	100	539	216	343	–	65	60	M20	M20	140	140	40	40
	4-8	508	100	622	624	406	–	100	539	216	343	–	80	75	M20	M20	170	140	40	40
315 SMA	2	508	100	622	624	406	457	100	539	216	443	392	65	60	M20	M20	140	140	40	40
	4-8	508	100	622	624	406	457	100	539	216	343	292	80	75	M20	M20	170	140	40	40
315 MB	2	508	100	622	624	457	–	100	539	216	392	–	65	60	M20	M20	140	140	40	40
	4-8	508	100	622	624	457	–	100	539	216	392	–	80	75	M20	M20	170	140	40	40
315 LA	2	508	100	622	624	508	–	100	592	216	411	–	65	60	M20	M20	140	140	40	40
	4-8	508	100	622	624	508	–	100	592	216	411	–	90	75	M24	M20	170	140	48	40
315 LB,LC	2	508	100	622	624	508	–	100	592	216	411	–	65	60	M20	M20	140	140	40	40
	4-8	508	100	622	624	508	–	100	592	216	411	–	90	75	M24	M20	170	140	48	40

Motor size	Poles <sup>1)</sup>	F	FA	G	GA	GB	GC	GD	GF	H	HA	HC	HD	K	L	LC	LD	O
280 SA	2	18	18	58	69	53	64	11	11	280	32	558	730	24	1060	1210	385	100
	4-8	20	18	67.5	79.5	58	69	12	11	280	32	558	730	24	990	1140	385	100
280 SMA	2	18	18	58	69	53	64	11	11	280	32	558	730	24	1060	1210	385	100
	4-8	20	18	67.5	79.5	58	69	12	11	280	32	558	730	24	1060	1210	385	100
280 MB	2	18	18	58	69	53	64	11	11	280	32	558	730	24	1120	1270	385	100
	4-8	20	18	67.5	79.5	58	69	12	11	280	32	558	730	24	1120	1270	385	100
280 MC	2	18	18	58	69	53	64	11	11	280	32	555	730	24	1255	1405	385	100
	4-8	20	18	67.5	79.5	58	69	12	11	280	32	558	730	24	1255	1405	385	100
280 MD	2	18	18	58	69	53	64	11	11	280	32	558	730	24	1255	1405	385	100
	4-8	20	18	67.5	79.5	58	69	12	11	280	32	558	730	24	1255	1405	385	100
315 SA	2	18	18	58	69	53	64	11	11	315	32	627	820	28	1095	1245	390	115
	4-8	22	20	71	85	67.5	79.5	14	12	315	32	627	820	28	1125	1275	420	115
315 SMA	2	18	18	58	69	53	64	11	11	315	32	627	820	28	1195	1345	390	115
	4-8	22	20	71	85	67.5	79.5	14	12	315	32	627	820	28	1125	1275	420	115
315 MB	2	18	18	58	69	53	64	11	11	315	32	627	820	28	1195	1345	390	115
	4-8	22	20	71	85	67.5	79.5	14	12	315	32	627	820	28	1225	1375	420	115
315 LA	2	18	18	58	69	53	64	11	11	315	32	627	820	28	1265	1415	390	115
	4-8	25	20	81	95	67.5	79.5	14	12	315	32	627	820	28	1295	1445	420	115
315 LB	2	18	18	58	69	53	64	11	11	315	32	627	820	28	1545	1695	390	115
	4-8	25	20	81	95	67.5	79.5	14	12	315	32	627	820	28	1575	1725	420	115
315 LC	2	18	18	58	69	53	64	11	11	315	32	627	848	28	1545	1695	390	115
	4	25	20	81	95	67.5	79.5	14	12	315	32	627	848	28	1575	1725	420	115
	6	25	20	81	95	67.5	79.5	14	12	315	32	627	820	28	1575	1725	420	115

Tolerances:

A, B ISO js14 H ISO 0, -1.0  
D, DA ISO m6  
F, FA ISO h9

<sup>1)</sup> Dimensions for 4-pole motors also valid for 4/6- and 4-8-pole two-speed motors.

<sup>2)</sup> Cooling distance.

<sup>3)</sup> Second shaft end on request.

Above dimensions are in mm.

For detailed drawings please see our web-pages 'www.abb.com/motors&drives' or contact us.

# General purpose steel motors

# Sizes 280-315

## Dimension drawings

Foot-mounted; IM B3 (IM 1001), IM B6 (IM 1051), IM B7 (IM 1061), IM B8 (IM 1071), IM V5 (IM 1011), IM V6 (IM 1031) – terminal box side mounted

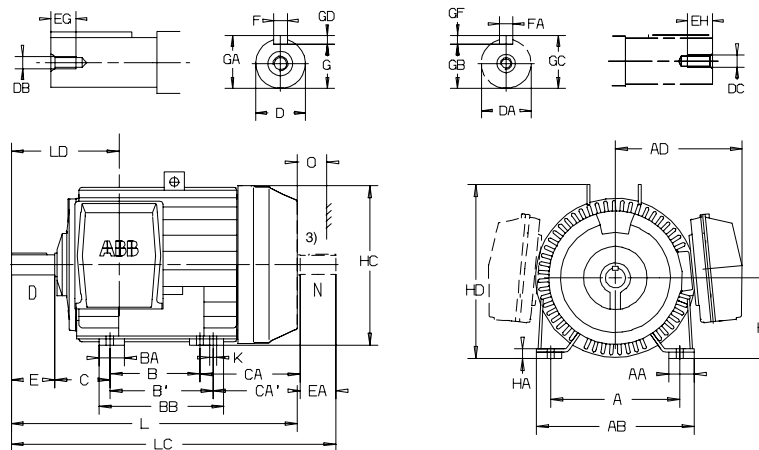

Motor size	Poles <sup>1)</sup>	A	AA	AB	AD	B	B'	BA	BB	C	CA	CA'	D	DA	DB	DC	E	EA	EG	EH
280 SA	2	457	80	545	448	368	–	100	501	190	372	–	65	60	M20	M20	140	140	40	40
	4-8	457	80	545	448	368	–	100	450	190	302	–	75	65	M20	M20	140	140	40	40
280 SMA	2	457	80	545	448	368	419	100	501	190	372	321	65	60	M20	M20	140	140	40	40
	4-8	457	80	545	448	368	419	100	501	190	372	321	75	65	M20	M20	140	140	40	40
280 MB	2	457	80	545	448	419	–	100	501	190	381	–	65	60	M20	M20	140	140	40	40
	4-8	457	80	545	448	419	–	100	501	190	381	–	75	65	M20	M20	140	140	40	40
280 MC,MD	2	457	80	545	448	419	–	100	501	190	381	–	65	60	M20	M20	140	140	40	40
	4-8	457	80	545	448	419	–	100	501	190	381	–	75	65	M20	M20	140	140	40	40
315 SA	2	508	100	622	502	406	–	100	539	216	343	–	65	60	M20	M20	140	140	40	40
	4-8	508	100	622	502	406	–	100	539	216	343	–	80	75	M20	M20	170	140	40	40
315 SMA	2	508	100	622	502	406	457	100	539	216	443	392	65	60	M20	M20	140	140	40	40
	4-8	508	100	622	502	406	457	100	539	216	343	292	80	75	M20	M20	170	140	40	40
315 MB	2	508	100	622	502	457	–	100	539	216	392	–	65	60	M20	M20	140	140	40	40
	4-8	508	100	622	502	457	–	100	539	216	392	–	80	75	M20	M20	170	140	40	40
315 LA	2	508	100	622	502	508	–	100	592	216	411	–	65	60	M20	M20	140	140	40	40
	4-8	508	100	622	502	508	–	100	592	216	411	–	90	75	M24	M20	170	140	48	40
315 LB,LC	2	508	100	622	502	508	–	100	592	216	411	–	65	60	M20	M20	140	140	40	40
	4-8	508	100	622	502	508	–	100	592	216	411	–	90	75	M24	M20	170	140	48	40

Motor size	Poles <sup>1)</sup>	F	FA	G	GA	GB	GC	GD	GF	H	HA	HC	HD	K	L	LC	LD	O
280 SA	2	18	18	58	69	53	64	11	11	280	32	558	620	24	1060	1210	385	100
	4-8	20	18	67.5	79.5	58	69	12	11	280	32	558	620	24	990	1140	385	100
280 SMA	2	18	18	58	69	53	64	11	11	280	32	558	620	24	1060	1210	385	100
	4-8	20	18	67.5	79.5	58	69	12	11	280	32	558	620	24	1060	1210	385	100
280 MB	2	18	18	58	69	53	64	11	11	280	32	558	620	24	1120	1270	385	100
	4-8	20	18	67.5	79.5	58	69	12	11	280	32	558	620	24	1120	1270	385	100
280 MC	2	18	18	58	69	53	64	11	11	280	32	558	620	24	1255	1405	385	100
	4-8	20	18	67.5	79.5	58	69	12	11	280	32	558	620	24	1255	1405	385	100
280 MD	2	18	18	58	69	53	64	11	11	280	32	558	620	24	1255	1405	385	100
	4-8	20	18	67.5	79.5	58	69	12	11	280	32	558	620	24	1255	1405	385	100
315 SA	2	18	18	58	69	53	64	11	11	315	32	627	685	28	1095	1245	390	115
	4-8	22	20	71	85	67.5	79.5	14	12	315	32	627	685	28	1125	1275	420	115
315 SMA	2	18	18	58	69	53	64	11	11	315	32	627	685	28	1195	1345	390	115
	4-8	22	20	71	85	67.5	79.5	14	12	315	32	627	685	28	1125	1275	420	115
315 MB	2	18	18	58	69	53	64	11	11	315	32	627	685	28	1195	1345	390	115
	4-8	22	20	71	85	67.5	79.5	14	12	315	32	627	685	28	1225	1375	420	115
315 LA	2	18	18	58	69	53	64	11	11	315	32	627	685	28	1265	1415	390	115
	4-8	25	20	81	95	67.5	79.5	14	12	315	32	627	685	28	1295	1445	420	115
315 LB,LC	2	18	18	58	69	53	64	11	11	315	32	627	685	28	1545	1695	390	115
	4-8	25	20	81	95	67.5	79.5	14	12	315	32	627	685	28	1575	1575	420	115

Tolerances:

A, B ISO js14 H ISO 0, -1.0  
D, DA ISO m6  
F, FA ISO h9

<sup>1)</sup> Dimensions for 4-pole motors also valid for 4/6- and 4-8-pole two-speed motors.

<sup>2)</sup> Cooling distance.

<sup>3)</sup> Second shaft end on request.

Above dimensions are in mm.

For detailed drawings please see our web-pages 'www.abb.com/motors&drives' or contact us.

# General purpose steel motors

# Sizes 355-400

## Dimension drawings

Foot-mounted; IM B3 (IM 1001), IM B6 (IM 1051), IM B7 (IM 1061), IM B8 (IM 1071), IM V5 (IM 1011), IM V6 (IM 1031) – terminal box top mounted

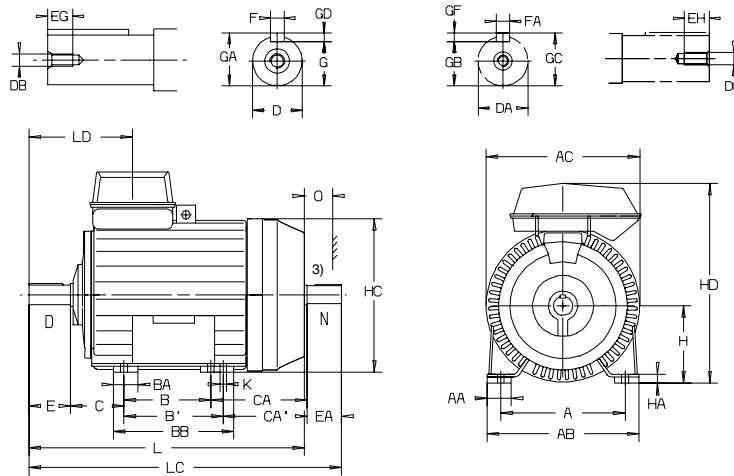

Motor size	Poles <sup>1)</sup>	A	AA	AB	AC	B	B'	BA	BB	C	CA	CA'	D	DA	DB	DC	E	EA	EG	EH
355 SA,SB	2	610	110	714	720	500	–	100	584	254	416	–	70	70	M20	M20	140	140	40	40
	4-8	610	110	714	720	500	–	100	584	254	416	–	100	90	M24	M20	210	170	48	48
355 MA	2	610	110	714	720	560	–	100	644	254	416	–	70	70	M20	M20	140	140	40	40
	4-8	610	110	714	720	560	–	100	644	254	416	–	100	90	M24	M24	210	170	48	48
355 MB	2	610	110	714	720	560	–	100	644	254	416	–	70	70	M20	M20	140	140	40	40
	4-8	610	110	714	720	560	–	100	644	254	416	–	100	90	M24	M24	210	170	48	48
355 LA	2	610	110	714	720	630	–	100	714	254	426	–	70	70	M20	M20	140	140	40	40
	4-8	610	110	714	720	630	–	100	714	254	426	–	100	90	M24	M24	210	170	48	48
355 LB	2	610	110	714	720	630	–	100	714	254	426	–	70	70	M20	M20	140	140	40	40
	4-8	610	110	714	720	630	–	100	714	254	426	–	100	90	M24	M24	210	170	48	48
355 LKD	4-8	610	110	714	720	630	710	100	802	254	583	503	100	90	M24	M24	210	170	48	48
400 MLA	2	686	140	820	810	630	710	140	850	280	583	503	70	70	M20	M20	140	140	40	40
	4-8	686	140	820	810	630	710	140	850	280	583	503	100	90	M24	M24	210	170	48	48
400 MLB	2	686	140	820	810	630	710	140	850	280	583	503	70	70	M20	M20	140	140	40	40
	4-8	686	140	820	810	630	710	140	850	280	583	503	100	90	M24	M24	210	170	48	48
400 LKA	2	686	140	820	810	710	800	140	935	280	643	553	80	75	M20	M20	170	140	40	40
	4-8	686	140	820	810	710	800	140	935	280	643	553	100	90	M24	M24	210	170	48	48
400 LKB	2	686	140	820	810	710	800	140	935	280	643	553	80	75	M20	M20	170	140	40	40
	4-8	686	140	820	810	710	800	140	935	280	643	553	100	90	M24	M24	210	170	48	48

Motor size	Poles <sup>1)</sup>	F	FA	G	GA	GB	GC	GD	GF	H	HA	HC	HD	K	L	LC	LD	O <sup>2)</sup>
355 SA,SB	2	20	20	62.5	74.5	62.5	74.5	12	12	355	36	715	920	28	1310	1460	392	130
	4-8	28	25	90	106	81	95	16	14	355	36	715	920	28	1380	1560	462	130
355 MA	2	20	20	62.5	74.5	62.5	74.5	12	12	355	36	715	920	28	1370	1520	392	130
	4-8	28	25	90	106	81	95	16	14	355	36	715	920	28	1440	1620	462	130
355 MB	2	20	20	62.5	74.5	62.5	74.5	12	12	355	36	715	920	28	1370	1520	392	130
	4-8	28	25	90	106	81	95	16	14	355	36	715	920	28	1440	1620	462	130
355 LA	2	20	20	62.5	74.5	62.5	74.5	12	12	355	36	715	920	28	1450	1600	392	130
	4-8	28	25	90	106	81	95	16	14	355	36	715	920	28	1520	1700	462	130
355 LB	2	20	20	62.5	74.5	62.5	74.5	12	12	355	36	715	920	28	1450	1600	392	130
	4-8	28	25	90	106	81	95	16	14	355	36	715	920	28	1520	1700	462	130
355 LKD	4-8	28	25	90	106	91	95	16	14	355	36	715	920	28	1660	1847	462	130
400 MLA	2	20	20	62.5	74.5	62.5	74.5	12	12	400	45	805	1003	35	1616	1773	408	150
	4-8	28	25	90	106	81	95	16	14	400	45	805	1003	35	1686	1873	478	150
400 MLB	2	20	20	62.5	74.5	62.5	74.5	12	12	400	45	805	1003	35	1616	1773	408	150
	4-8	28	25	90	106	81	95	16	14	400	45	805	1003	35	1686	1873	478	150
400 LKA	2	22	20	71	85	67.5	79.5	14	12	400	45	805	1003	35	1786	1943	438	150
	4-8	28	25	90	106	81	95	16	14	400	45	805	1003	35	1826	2013	478	150
400 LKB	2	22	20	71	85	67.5	79.5	14	12	400	45	805	1003	35	1786	1943	438	150
	4-8	28	25	90	106	81	95	16	14	400	45	805	1003	35	1826	2013	478	150

### Tolerances:

A, B	ISO js14	H	ISO 0, -1.0
D, DA	ISO m6		
F, FA	ISO h9		

<sup>1)</sup> Dimensions for 4-pole motors also valid for 4/6- and 4-8 pole two-speed motors.

<sup>2)</sup> Cooling distance.

<sup>3)</sup> Second shaft end on request.

Above dimensions are in mm.

For detailed drawings please see our web-pages 'www.abb.com/motors&drives' or contact us.

# General purpose steel motors

# Sizes 355-400

## Dimension drawings

Foot-mounted; IM B3 (IM 1001), IM B6 (IM 1051), IM B7 (IM 1061), IM B8 (IM 1071), IM V5 (IM 1011), IM V6 (IM 1031) – terminal box side mounted

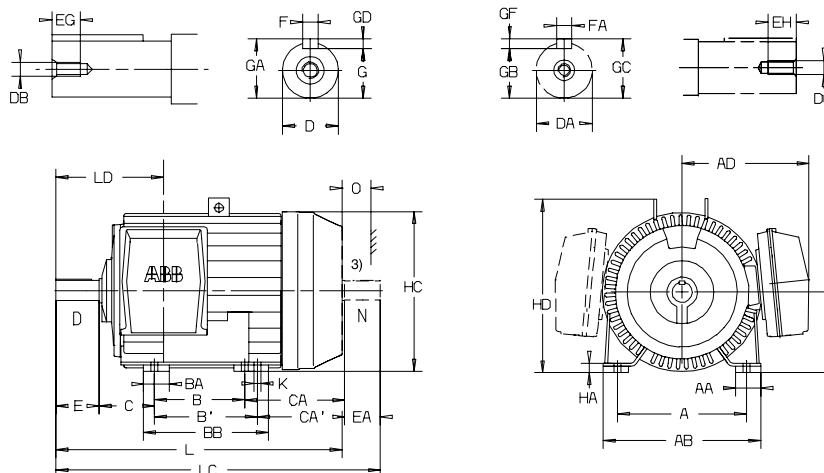

Motor size	Poles <sup>1)</sup>	A	AA	AB	AD	B	B'	BA	BB	C	CA	CA'	D	DA	DB	DC	E	EA	EG	EH
355 SA,SB	2	610	110	714	570	500	–	100	584	254	416	–	70	70	M20	M20	140	140	40	40
	4-8	610	110	714	570	500	–	100	584	254	416	–	100	90	M24	M20	210	170	48	48
355 MA	2	610	110	714	570	560	–	100	644	254	416	–	70	70	M20	M20	140	140	40	40
	4-8	610	110	714	570	560	–	100	644	254	416	–	100	90	M24	M24	210	170	48	48
355 MB	2	610	110	714	570	560	–	100	644	254	416	–	70	70	M20	M20	140	140	40	40
	4-8	610	110	714	570	560	–	100	644	254	416	–	100	90	M24	M24	210	170	48	48
355 LA	2	610	110	714	570	630	–	100	714	254	426	–	70	70	M20	M20	140	140	40	40
	4-8	610	110	714	570	630	–	100	714	254	426	–	100	90	M24	M24	210	170	48	48
355 LB	2	610	110	714	570	630	–	100	714	254	426	–	70	70	M20	M20	140	140	40	40
	4-8	610	110	714	570	630	–	100	714	254	426	–	100	90	M24	M24	210	170	48	48
355 LKD	4-8	610	110	714	570	630	710	100	802	254	583	503	100	90	M24	M24	210	170	48	48
400 MLA	2	686	140	820	603	630	710	140	850	280	583	503	70	70	M20	M20	140	140	40	40
	4-8	686	140	820	603	630	710	140	850	280	583	503	100	90	M24	M24	210	170	48	48
400 MLB	2	686	140	820	603	630	710	140	850	280	583	503	70	70	M20	M20	140	140	40	40
	4-8	686	140	820	603	630	710	140	850	280	583	503	100	90	M24	M24	210	170	48	48
400 LKA	2	686	140	820	603	710	800	140	935	280	643	553	80	75	M20	M20	170	140	40	40
	4-8	686	140	820	603	710	800	140	935	280	643	553	100	90	M24	M24	210	170	48	48
400 LKB	2	686	140	820	603	710	800	140	935	280	643	553	80	75	M20	M20	170	140	40	40
	4-8	686	140	820	603	710	800	140	935	280	643	553	100	90	M24	M24	210	170	48	48

Motor size	Poles <sup>1)</sup>	F	FA	G	GA	GB	GC	GD	GF	H	HA	HC	HD	K	L	LC	LD	O <sup>2)</sup>
355 SA,SB	2	20	20	62.5	74.5	62.5	74.5	12	12	355	36	715	768	28	1310	1460	392	130
	4-8	28	25	90	106	81	95	16	14	355	36	715	768	28	1380	1560	462	130
355 MA	2	20	20	62.5	74.5	62.5	74.5	12	12	355	36	715	768	28	1370	1520	392	130
	4-8	28	25	90	106	81	95	16	14	355	36	715	768	28	1440	1620	462	130
355 MB	2	20	20	62.5	74.5	62.5	74.5	12	12	355	36	715	768	28	1370	1520	392	130
	4-8	28	25	90	106	81	95	16	14	355	36	715	768	28	1440	1620	462	130
355 LA	2	20	20	62.5	74.5	62.5	74.5	12	12	355	36	715	768	28	1450	1600	392	130
	4-8	28	25	90	106	81	95	16	14	355	36	715	768	28	1520	1700	462	130
355 LB	2	20	20	62.5	74.5	62.5	74.5	12	12	355	36	715	768	28	1450	1600	392	130
	4-8	28	25	90	106	81	95	16	14	355	36	715	768	28	1520	1700	462	130
355 LKD	4-8	28	25	90	106	91	95	16	14	355	36	715	768	28	1660	1847	462	130
400 MLA	2	20	20	62.5	74.5	62.5	74.5	12	12	400	45	805	900	35	1616	1773	408	150
	4-8	28	25	90	106	81	95	16	14	400	45	805	900	35	1686	1873	478	150
400 MLB	2	20	20	62.5	74.5	62.5	74.5	12	12	400	45	805	900	35	1616	1773	408	150
	4-8	28	25	90	106	81	95	16	14	400	45	805	900	35	1686	1873	478	150
400 LKA	2	22	20	71	85	67.5	79.5	14	12	400	45	805	900	35	1786	1943	438	150
	4-8	28	25	90	106	81	95	16	14	400	45	805	900	35	1826	2013	478	150
400 LKB	2	22	20	71	85	67.5	79.5	14	12	400	45	805	900	35	1786	1943	438	150
	4-8	28	25	90	106	81	95	16	14	400	45	805	900	35	1826	2013	478	150

Tolerances:

A, B ISO js14 H ISO 0, -1.0  
 D, DA ISO m6  
 F, FA ISO h9

- <sup>1)</sup> Dimensions for 4-pole motors also valid for 4/6- and 4-8 -pole two-speed motors.
- <sup>2)</sup> Cooling distance.
- <sup>3)</sup> Second shaft end on request.

Above dimensions are in mm.  
 For detailed drawings please see our web-pages 'www.abb.com/motors&drives' or contact us.

# General purpose steel motors

# Sizes 280-315

## Dimension drawings

Flange-mounted; IM B5 (IM 3001), V1 (IM 3011), V3 (IM 3031) and IM B14 (IM 3601), V18 (IM 3611), V19 (IM 3631)

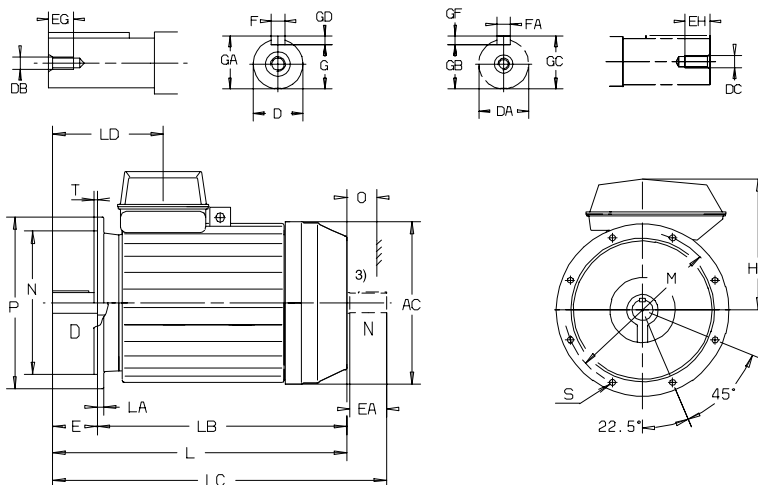

Motor size	Poles 1)	AC	D	DA	DB	DC	E	EA	EG	EH	F	FA	G	GA	GB	GC
280 SA	2	555	65	60	M20	M20	140	140	40	40	18	18	58	69	53	64
	4-8	555	75	65	M20	M20	140	140	40	40	20	18	67.5	79.5	58	69
280 SMA	2	555	65	60	M20	M20	140	140	40	40	18	18	58	69	53	64
	4-8	555	75	65	M20	M20	140	140	40	40	20	18	67.5	79.5	58	69
280 MB	2	555	65	60	M20	M20	140	140	40	40	18	18	58	69	53	64
	4-8	555	75	65	M20	M20	140	140	40	40	20	18	67.5	79.5	58	69
280 MC,MD	2	555	65	60	M20	M20	140	140	40	40	18	18	58	69	53	64
	4-8	555	75	65	M20	M20	140	140	40	40	20	18	67.5	79.5	58	69
315 SA	2	624	65	60	M20	M20	140	140	40	40	18	18	58	69	53	64
	4-8	624	80	75	M20	M20	170	140	40	40	22	20	71	85	67.5	79.5
315 SMA	2	624	65	60	M20	M20	140	140	40	40	18	18	58	69	53	64
	4-8	624	80	75	M20	M20	170	140	40	40	22	20	71	85	67.5	79.5
315 MB	2	624	65	60	M20	M20	140	140	40	40	18	18	58	69	53	64
	4-8	624	80	75	M20	M20	170	140	40	40	22	20	71	85	67.5	79.5
315 LA	2	624	65	60	M20	M20	140	140	40	40	18	18	58	69	53	64
	4-8	624	90	75	M24	M20	170	140	48	40	25	20	81	95	67.5	79.5
315 LB,LC	2	624	65	60	M20	M20	140	140	40	40	18	18	58	69	53	64
	4-8	624	90	75	M24	M20	170	140	48	40	25	20	81	95	67.5	79.5

Motor size	Poles 1)	GD	GF	HB	L	LA	LB	LC	LD	M	N	O 2)	P	S	T
280 SA	2	11	11	450	1060	22	920	1210	385	500	450	100	550	18	5
	4-8	12	11	450	990	22	850	1140	385	500	450	100	550	18	5
280 SMA	2	11	11	450	1060	22	920	1210	385	500	450	100	550	18	5
	4-8	12	11	450	1060	22	920	1210	385	500	450	100	550	18	5
280 MB	2	11	11	450	1120	22	980	1270	385	500	450	100	550	18	5
	4-8	12	11	450	1120	22	980	1270	385	500	450	100	550	18	5
280 MC	2	11	11	450	1255	22	980	1405	385	500	450	100	550	18	5
	4-8	12	11	450	1255	22	980	1405	385	500	450	100	550	18	5
280 MD	2	11	11	450	1255	22	980	1405	385	500	450	100	550	18	5
	4-8	12	11	450	1255	22	980	1405	385	500	450	100	550	18	5
315 SA	2	11	11	505	1095	25	955	1245	390	600	550	115	660	23	6
	4-8	14	12	505	1125	25	955	1275	420	600	550	115	660	23	6
315 SMA	2	11	11	505	1195	25	1055	1345	390	600	550	115	660	23	6
	4-8	14	12	505	1125	25	955	1275	420	600	550	115	660	23	6
315 MB	2	11	11	505	1195	25	1055	1345	390	600	550	115	660	23	6
	4-8	14	12	505	1225	25	1055	1375	420	600	550	115	660	23	6
315 LA	2	11	11	505	1265	25	1125	1415	390	600	550	115	660	23	6
	4-8	14	12	505	1295	25	1125	1445	420	600	550	115	660	23	6
315 LB	2	11	11	505	1545	25	1125	1415	390	600	550	115	660	23	6
	4-8	14	12	505	1575	25	1405	1725	420	600	550	115	660	23	6
315 LC	2	11	11	505	1545	25	1125	1415	390	600	550	115	660	23	6
	4-8	14	12	526	1575	25	1405	1725	420	600	550	115	660	23	6

Tolerances:

D,DA ISO m6  
F, FA ISO h9  
N ISO j6

1) Dimensions for 4-pole motors also valid for 4/6- and 4-8 -pole two-speed motors.

2) Cooling distance.

3) Second shaft end on request.

Above dimensions are in mm.

For detailed drawings please see our web-pages 'www.abb.com/motors&drives' or contact us.



# General purpose steel motors

# Sizes 355-400

## Dimension drawings

Flange-mounted; IM B5 (IM 3001), V1 (IM 3011), V3 (IM 3031) and IM B14 (IM 3601), V18 (IM 3611), V19 (IM 3631)

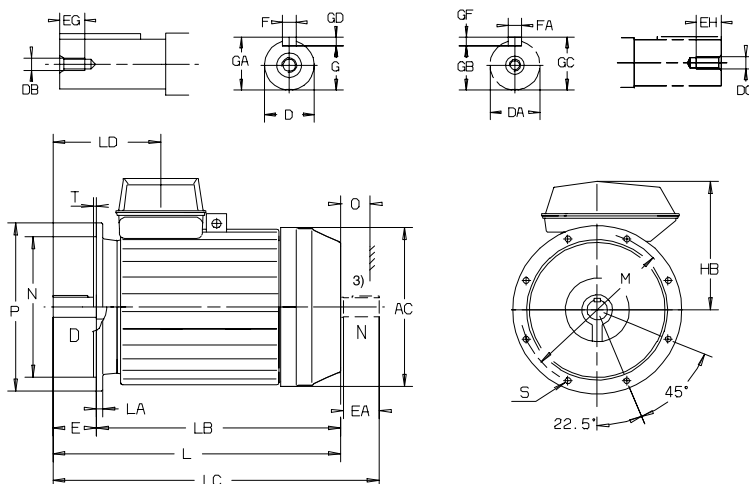

Motor size	Poles <sup>1)</sup>	AC	D	DA	DB	DC	E	EA	EG	EH	F	FA	G	GA	GB	GC
355 SA,SB	2	720	70	70	M20	M20	140	140	40	40	20	20	62.5	74.5	62.5	74.5
	4-8	720	100	90	M24	M24	210	170	48	48	28	25	90	106	81	95
355 MA	2	720	70	70	M20	M20	140	140	40	40	20	20	62.5	74.5	62.5	74.5
	4-8	720	100	90	M24	M24	210	170	48	48	28	25	90	106	81	95
355 MB	2	720	70	70	M20	M20	140	140	40	40	20	20	62.5	74.5	62.5	74.5
	4-8	720	100	90	M24	M24	210	170	48	48	28	25	90	106	81	95
355 LA	2	720	70	70	M20	M20	140	140	40	40	20	20	62.5	74.5	62.5	74.5
	4-8	720	100	90	M24	M24	210	170	48	48	28	25	90	106	81	95
355 LB	2	720	70	70	M20	M20	140	140	40	40	20	20	62.5	74.5	62.5	74.5
	4-8	720	100	90	M24	M24	210	170	48	48	28	25	90	106	81	95
355 LKD	4-8	720	100	90	M24	M24	210	170	48	48	28	25	90	106	81	95
400 MLA	2	810	70	70	M20	M20	140	140	40	40	20	20	62.5	74.5	62.5	74.5
	4-8	810	100	90	M24	M24	210	170	48	48	28	25	90	106	81	95
400 MLB	2	810	70	70	M20	M20	140	140	40	40	20	20	62.5	74.5	62.5	74.5
	4-8	810	100	90	M24	M24	210	170	48	48	28	25	90	106	81	95
400 LKA	2	810	80	75	M20	M20	170	140	40	40	22	20	71	85	67.5	79.5
	4-8	810	100	90	M24	M24	210	170	48	48	28	25	90	106	81	95
400 LKB	2	810	80	75	M20	M20	170	140	40	40	22	20	71	85	67.5	79.5
	4-8	810	100	90	M24	M24	210	170	48	48	28	25	90	106	81	95

Motor size	Poles <sup>1)</sup>	GD	GF	HB	L	LA	LB	LC	LD	M	N	O <sup>2)</sup>	P	S	T
355 SA,SB	2	12	12	565	1310	25	1170	1460	392	740	680	130	800	23	6
	4-8	16	14	565	1380	25	1170	1560	462	740	680	130	800	23	6
355 MA	2	12	12	565	1370	25	1230	1520	392	740	680	130	800	23	6
	4-8	16	14	565	1440	25	1230	1620	462	740	680	130	800	23	6
355 MB	2	12	12	565	1370	25	1230	1520	392	740	680	130	800	23	6
	4-8	16	14	565	1440	25	1230	1620	462	740	680	130	800	23	6
355 LA	2	12	12	565	1450	25	1310	1600	392	740	680	130	800	23	6
	4-8	16	14	565	1520	25	1310	1700	462	740	680	130	800	23	6
355 LB	2	12	12	565	1450	25	1310	1600	392	740	680	130	800	23	6
	4-8	16	14	565	1520	25	1310	1700	462	740	680	130	800	23	6
355 LKD	4-8	16	14	565	1660	25	1450	1847	462	740	680	130	800	23	6
400 MLA	2	12	12	603	1616	25	1476	1773	408	740	680	150	800	23	6
	4-8	16	14	603	1686	25	1476	1873	478	740	680	150	800	23	6
400 MLB	2	12	12	603	1616	25	1476	1773	408	740	680	150	800	23	6
	4-8	16	14	603	1686	25	1476	1873	478	740	680	150	800	23	6
400 LKA	2	14	12	603	1786	25	1616	1943	438	740	680	150	800	23	6
	4-8	16	14	603	1826	25	1616	2013	478	740	680	150	800	23	6
400 LKB	2	14	12	603	1786	25	1616	1943	438	740	680	150	800	23	6
	4-8	16	14	603	1826	25	1616	2013	478	740	680	150	800	23	6

Tolerances:

D,DA ISO m6  
F, FA ISO h9  
N ISO j6

- 1) Dimensions for 4-pole motors also valid for 4/6- and 4-8 -pole two-speed motors.
- 2) Cooling distance.
- 3) Second shaft end on request.

Above dimensions are in mm.  
For detailed drawings please see our web-pages 'www.abb.com/motors&drives' or contact us.

# General purpose steel motors

# Sizes 280-315

## Dimension drawings

Foot- and flange-mounted; IM B35 (IM 2001), IM V15 (IM 2011), IM V36 (IM 2031) – terminal box top mounted

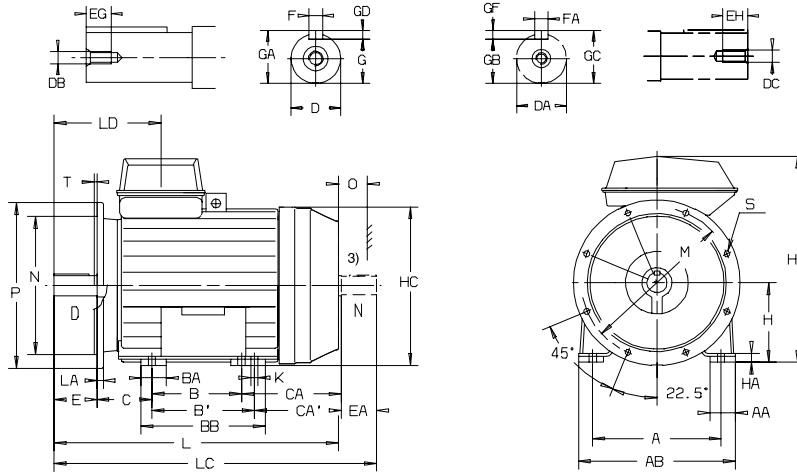

Motor size	Poles 1)	A	AA	AB	B	B'	BA	BB	C	CA	CA'	D	DA	DB	DC	E	EA	EG	EH	F	FA
280 SA	2	457	80	545	368	–	100	501	190	372	–	65	60	M20	M20	140	140	40	40	18	18
	4-8	457	80	545	368	–	100	501	190	302	–	75	65	M20	M20	140	140	40	40	20	18
280 SMA	2	457	80	545	368	419	100	501	190	372	321	65	60	M20	M20	140	140	40	40	18	18
	4-8	457	80	545	368	419	100	501	190	372	321	75	65	M20	M20	140	140	40	40	20	18
280 MB	2	457	80	545	419	–	100	501	190	381	–	65	60	M20	M20	140	140	40	40	18	18
	4-8	457	80	545	419	–	100	501	190	381	–	75	65	M20	M20	140	140	40	40	20	18
280 MC,MD	2	457	80	545	419	–	100	501	190	381	–	65	60	M20	M20	140	140	40	40	18	18
	4-8	457	80	545	419	–	100	501	190	381	–	75	65	M20	M20	140	140	40	40	20	18
315 SA	2	508	100	622	406	–	100	539	216	343	–	65	60	M20	M20	140	140	40	40	18	18
	4-8	508	100	622	406	–	100	539	216	343	–	80	75	M20	M20	170	140	40	40	22	20
315 SMA	2	508	100	622	406	457	100	539	216	443	392	65	60	M20	M20	140	140	40	40	18	18
	4-8	508	100	622	406	457	100	539	216	343	292	80	75	M20	M20	170	140	40	40	22	20
315 MB	2	508	100	622	457	–	100	539	216	392	–	65	60	M20	M20	140	140	40	40	18	18
	4-8	508	100	622	457	–	100	539	216	392	–	80	75	M20	M20	170	140	40	40	22	20
315 LA	2	508	100	622	508	–	100	592	216	411	–	65	60	M20	M20	140	140	40	40	18	18
	4-8	508	100	622	508	–	100	592	216	411	–	90	75	M24	M20	170	140	48	40	25	20
315 LB,LC	2	508	100	622	508	–	100	592	216	411	–	65	60	M20	M20	140	140	40	40	18	18
	4-8	508	100	622	508	–	100	592	216	411	–	90	75	M24	M20	170	140	48	40	25	20

Motor size	Poles 1)	G	GA	GB	GC	GD	GF	H	HA	HC	HD	K	L	LC	LD	M	N	O	P	S	T
280 SA	2	58	69	53	64	11	11	280	32	558	730	24	1060	1210	385	500	450	100	550	18	5
	4-8	67.5	79.5	58	69	12	11	280	32	558	730	24	990	1140	385	500	450	100	550	18	5
280 SMA	2	58	69	53	64	11	11	280	32	558	730	24	1060	1210	385	500	450	100	550	18	5
	4-8	67.5	79.5	58	69	12	11	280	32	558	730	24	1060	1210	385	500	450	100	550	18	5
280 MB	2	58	69	53	64	11	11	280	32	558	730	24	1120	1270	385	500	450	100	550	18	5
	4-8	67.5	79.5	58	69	12	11	280	32	558	730	24	1120	1270	385	500	450	100	550	18	5
280 MC	2	58	69	53	64	11	11	280	32	558	730	24	1255	1405	385	500	450	100	550	18	5
	4-8	67.5	79.5	58	69	12	11	280	32	558	730	24	1225	1405	385	500	450	100	550	18	5
280 MD	2	58	69	53	64	11	11	280	32	558	730	24	1255	1405	385	500	450	100	550	18	5
	4-8	67.5	79.5	58	69	12	11	280	32	558	730	24	1255	1405	385	500	450	100	550	18	5
315 SA	2	58	69	53	64	11	11	315	32	627	820	28	1095	1245	390	600	550	115	660	23	6
	4-8	71	85	67.5	79.5	14	12	315	32	627	820	28	1125	1275	420	600	550	115	660	23	6
315 SMA	2	58	69	53	64	11	11	315	32	627	820	28	1195	1345	390	600	550	115	660	23	6
	4-8	71	85	67.5	79.5	14	12	315	32	627	820	28	1125	1275	420	600	550	115	660	23	6
315 MB	2	58	69	53	64	11	11	315	32	627	820	28	1195	1345	390	600	550	115	660	23	6
	4-8	71	85	67.5	79.5	14	12	315	32	627	820	28	1225	1375	420	600	550	115	660	23	6
315 LA	2	58	69	53	64	11	11	315	32	627	820	28	1265	1415	390	600	550	115	660	23	6
	4-8	81	95	67.5	79.5	14	12	315	32	627	820	28	1295	1445	420	600	550	115	660	23	6
315 LB	2	58	69	53	64	11	11	315	32	627	820	28	1545	1695	390	600	550	115	660	23	6
	4-8	81	95	67.5	79.5	14	12	315	32	627	820	28	1575	1725	420	600	550	115	660	23	6
315 LC	2	58	69	53	64	11	11	315	32	627	848	28	1545	1695	390	600	550	115	660	23	6
	4	81	95	67.5	79.5	14	12	315	32	627	848	28	1575	1725	420	600	550	115	660	23	6
	6	81	95	67.5	79.5	14	12	315	32	627	820	28	1575	1725	420	600	550	115	660	23	6

Tolerances:

A, B ISO js14  
D, DA ISO m6  
F, FA ISO h9

1) Dimensions for 4-pole motors also valid for 4/6- and 4-8 pole two-speed motors.  
2) Cooling distance.  
3) Second shaft end on request.

Above dimensions are in mm.  
For detailed drawings please see our web-pages 'www.abb.com/motors&drives' or contact us.

# General purpose steel motors

# Sizes 280-315

## Dimension drawings

Foot- and flange-mounted; IM B35 (IM 2001), IM V15 (IM 2011), IM V36 (IM 2031) – terminal box side mounted

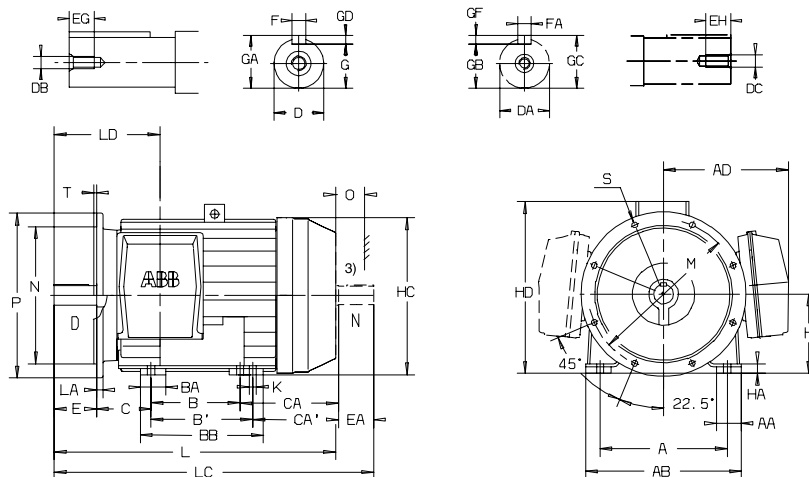

Motor size	Poles <sup>1)</sup>	A	AA	AB	AD	B	B'	BA	BB	C	CA	CA'	D	DA	DB	DC	E	EA	EG	EH	F	FA
280 SA	2	457	80	545	448	368	—	100	501	190	372	—	65	60	M20	M20	140	140	40	40	18	18
	4-8	457	80	545	448	368	—	100	501	190	302	—	75	65	M20	M20	140	140	40	40	20	18
280 SMA	2	457	80	545	448	368	419	100	501	190	372	321	65	60	M20	M20	140	140	40	40	18	18
	4-8	457	80	545	448	368	419	100	501	190	372	321	75	65	M20	M20	140	140	40	40	20	18
280 MB	2	457	80	545	448	419	—	100	501	190	381	—	65	60	M20	M20	140	140	40	40	18	18
	4-8	457	80	545	448	419	—	100	501	190	381	—	75	65	M20	M20	140	140	40	40	20	18
280 MC,MD	2	457	80	545	448	419	—	100	501	190	381	—	65	60	M20	M20	140	140	40	40	18	18
	4-8	457	80	545	448	419	—	100	501	190	381	—	75	65	M20	M20	140	140	40	40	20	18
315 SA	2	508	100	622	502	406	—	100	539	216	343	—	65	60	M20	M20	140	140	40	40	18	18
	4-8	508	100	622	502	406	—	100	539	216	343	—	80	75	M20	M20	170	140	40	40	22	20
315 SMA	2	508	100	622	502	406	457	100	539	216	443	392	65	60	M20	M20	140	140	40	40	18	18
	4-8	508	100	622	502	406	457	100	539	216	343	292	80	75	M20	M20	170	140	40	40	22	20
315 MB	2	508	100	622	502	457	—	100	539	216	392	—	65	60	M20	M20	140	140	40	40	18	18
	4-8	508	100	622	502	457	—	100	539	216	392	—	80	75	M20	M20	170	140	40	40	22	20
315 LA	2	508	100	622	502	508	—	100	592	216	411	—	65	60	M20	M20	140	140	40	40	18	18
	4-8	508	100	622	502	508	—	100	592	216	411	—	90	75	M24	M20	170	140	48	40	25	20
315 LB,LC	2	508	100	622	502	508	—	100	592	216	411	—	65	60	M20	M20	140	140	40	40	18	18
	4-8	508	100	622	502	508	—	100	592	216	411	—	90	75	M24	M20	170	140	48	40	25	20

Motor size	Poles <sup>1)</sup>	G	GA	GB	GC	GD	GF	H	HA	HC	HD	K	L	LC	LD	M	N	O	P	S	T
280 SA	2	58	69	53	64	11	11	280	32	558	620	24	1060	1210	385	500	450	100	550	18	5
	4-8	67.5	79.5	58	69	12	11	280	32	558	620	24	990	1140	385	500	450	100	550	18	5
280 SMA	2	58	69	53	64	11	11	280	32	558	620	24	1060	1210	385	500	450	100	550	18	5
	4-8	67.5	79.5	58	69	12	11	280	32	558	620	24	1060	1210	385	500	450	100	550	18	5
280 MB	2	58	69	53	64	11	11	280	32	558	620	24	1120	1270	385	500	450	100	550	18	5
	4-8	67.5	79.5	58	69	12	11	280	32	558	620	24	1120	1270	385	500	450	100	550	18	5
280 MC	2	58	69	53	64	11	11	280	32	558	620	24	1255	1405	385	500	450	100	550	18	5
	4-8	67.5	79.5	58	69	12	11	280	32	558	620	24	1255	1405	385	500	450	100	550	18	5
280 MD	2	58	69	53	64	11	11	280	32	558	620	24	1255	1405	385	500	450	100	550	18	5
	4-8	67.5	79.5	58	69	12	11	280	32	558	620	24	1255	1405	385	500	450	100	550	18	5
315 SA	2	58	69	53	64	11	11	315	32	627	685	28	1095	1245	390	600	550	115	660	23	6
	4-8	71	85	67.5	79.5	14	12	315	32	627	685	28	1125	1275	420	600	550	115	660	23	6
315 SMA	2	58	69	53	64	11	11	315	32	627	685	28	1195	1345	390	600	550	115	660	23	6
	4-8	71	85	67.5	79.5	14	12	315	32	627	685	28	1125	1275	420	600	550	115	660	23	6
315 MB	2	58	69	53	64	11	11	315	32	627	685	28	1195	1345	390	600	550	115	660	23	6
	4-8	71	85	67.5	79.5	14	12	315	32	627	685	28	1225	1375	420	600	550	115	660	23	6
315 LA	2	58	69	53	64	11	11	315	32	627	685	28	1265	1415	390	600	550	115	660	23	6
	4-8	81	95	67.5	79.5	14	12	315	32	627	685	28	1295	1445	420	600	550	115	660	23	6
315 LB,LC	2	58	69	53	64	11	11	315	32	627	685	28	1545	1695	390	600	550	115	660	23	6
	4-8	81	95	67.5	79.5	14	12	315	32	627	685	28	1575	1725	420	600	550	115	660	23	6

Tolerances:

A, B ISO js14 H ISO 0, -1.0  
 D, DA ISO m6 N ISO j6  
 F, FA ISO h9

<sup>1)</sup> Dimensions for 4-pole motors also valid for 4/6- and 4-8 -pole two-speed motors.  
<sup>2)</sup> Cooling distance.  
<sup>3)</sup> Second shaft end on request.

Above dimensions are in mm.  
 For detailed drawings please see our web-pages 'www.abb.com/motors&drives' or contact us.

# General purpose steel motors

# Sizes 355-400

## Dimension drawings

Foot- and flange-mounted; IM B35 (IM 2001), IM V15 (IM 2011), IM V36 (IM 2031) – terminal box top mounted

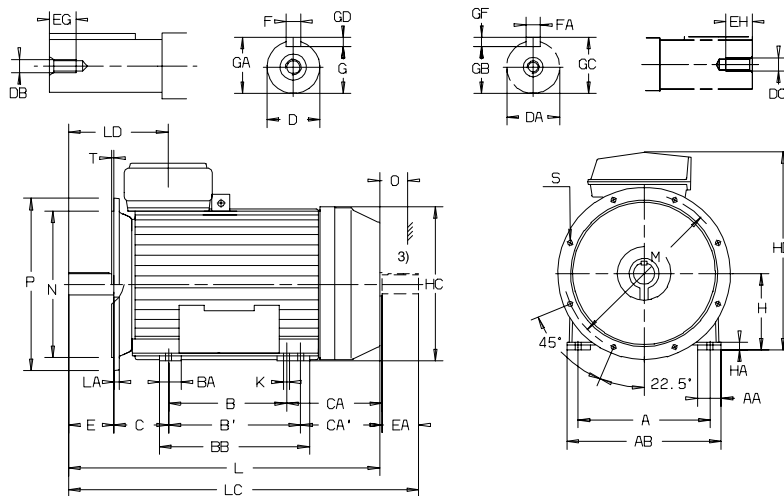

Motor size	Poles A <sup>1)</sup>	AA	AB	B	B'	BA	BB	C	CA	CA'	D	DA	DB	DC	E	EA	EG	EH	F	FA	
355 SA,SB	2	610	110	714	500	—	100	584	254	426	—	70	70	M20	M20	140	140	40	40	20	20
	4-8	610	110	714	500	—	100	584	254	426	—	100	90	M24	M20	210	170	48	48	28	25
355 MA	2	610	110	714	560	—	100	644	254	426	—	70	70	M20	M20	140	140	40	40	20	20
	4-8	610	110	714	560	—	100	644	254	426	—	100	90	M24	M24	210	170	48	48	28	25
355 MB	2	610	110	714	560	—	100	644	254	426	—	70	70	M20	M20	140	140	40	40	20	20
	4-8	610	110	714	560	—	100	644	254	426	—	100	90	M24	M24	210	170	48	48	28	25
355 LA	2	610	110	714	630	—	100	714	254	436	—	70	70	M20	M20	140	140	40	40	20	20
	4-8	610	110	714	630	—	100	714	254	436	—	100	90	M24	M24	210	170	48	48	28	25
355 LB	2	610	110	714	630	—	100	714	254	436	—	70	70	M20	M20	140	140	40	40	20	20
	4-8	610	110	714	630	—	100	714	254	436	—	100	90	M24	M24	210	170	48	48	28	25
355 LKD	2	610	110	714	630	710	100	802	254	583	503	100	90	M24	M24	210	170	48	48	28	25
	4-8	610	110	714	630	710	100	802	254	583	503	100	90	M24	M24	210	170	48	48	28	25
400 MLA	2	686	140	820	630	710	140	850	280	583	503	70	70	M20	M20	140	140	40	40	20	20
	4-8	686	140	820	630	710	140	850	280	583	503	100	90	M24	M24	210	170	48	48	28	25
400 MLB	2	686	140	820	630	710	140	850	280	583	503	70	70	M20	M20	140	140	40	40	20	20
	4-8	686	140	820	630	710	140	850	280	583	503	100	90	M24	M24	210	170	48	48	28	25
400 LKA	2	686	140	820	710	800	140	935	280	643	553	80	75	M20	M20	170	140	40	40	22	20
	4-8	686	140	820	710	800	140	935	280	643	553	100	90	M24	M24	210	170	48	48	28	25
400 LKB	2	686	140	820	710	800	140	935	280	643	553	80	75	M20	M20	170	140	40	40	22	20
	4-8	686	140	820	710	800	140	935	280	643	553	100	90	M24	M24	210	170	48	48	28	25

Motor size	Poles G <sup>1)</sup>	GA	GB	GC	GD	GF	H	HA	HC	HD	K	L	LC	LD	M	N	O <sup>2)</sup>	P	S	T	
355 SA,SB	2	62.5	74.5	62.5	74.5	12	12	355	36	715	920	28	1310	1460	392	740	680	130	800	23	6
	4-8	90	106	81	95	16	14	355	36	715	920	28	1380	1560	462	740	680	130	800	23	6
355 MA	2	62.5	74.5	62.5	74.5	12	12	355	36	715	920	28	1370	1520	392	740	680	130	800	23	6
	4-8	90	106	81	95	16	14	355	36	715	920	28	1440	1620	462	740	680	130	800	23	6
355 MB	2	62.5	74.5	62.5	74.5	12	12	355	36	715	920	28	1370	1520	392	740	680	130	800	23	6
	4-8	90	106	81	95	16	14	355	36	715	920	28	1440	1620	462	740	680	130	800	23	6
355 LA	2	62.5	74.5	62.5	74.5	12	12	355	36	715	920	28	1450	1600	392	740	680	130	800	23	6
	4-8	90	106	81	95	16	14	355	36	715	920	28	1520	1700	462	740	680	130	800	23	6
355 LB	2	62.5	74.5	62.5	74.5	12	12	355	36	715	920	28	1450	1600	392	740	680	130	800	23	6
	4-8	90	106	81	95	16	14	355	36	715	920	28	1520	1700	462	740	680	130	800	23	6
355 LKD	2	62.5	74.5	62.5	74.5	12	12	355	36	715	920	28	1660	1847	462	740	680	130	800	23	6
	4-8	90	106	81	95	16	14	355	36	715	920	28	1730	1927	542	740	680	130	800	23	6
400 MLA	2	62.5	74.5	62.5	74.5	12	12	400	45	805	1003	35	1616	1773	408	740	680	150	800	23	6
	4-8	90	106	81	95	16	14	400	45	805	1003	35	1686	1873	478	740	680	150	800	23	6
400 MLB	2	62.5	74.5	62.5	74.5	12	12	400	45	805	1003	35	1616	1773	408	740	680	150	800	23	6
	4-8	90	106	81	95	16	14	400	45	805	1003	35	1686	1873	478	740	680	150	800	23	6
400 LKA	2	71	85	67.5	79.5	14	12	400	45	805	1003	35	1786	1943	438	740	680	150	800	23	6
	4-8	90	106	81	95	16	14	400	45	805	1003	35	1826	2013	478	740	680	150	800	23	6
400 LKB	2	71	85	67.5	79.5	14	12	400	45	805	1003	35	1786	1943	438	740	680	150	800	23	6
	4-8	90	106	81	95	16	14	400	45	805	1003	35	1826	2013	478	740	680	150	800	23	6

Tolerances:

A, B	ISO js14	H	ISO 0, -1.0
D, DA	ISO m6	N	ISO j6
F, FA	ISO h9		

<sup>1)</sup> Dimensions for 4-pole motors also valid for 4/6- and 4-8 -pole two-speed motors.

<sup>2)</sup> Cooling distance.

<sup>3)</sup> Second shaft end on request.

Above dimensions are in mm.

For detailed drawings please see our web-pages 'www.abb.com/motors&drives' or contact us.

# General purpose steel motors

# Sizes 355-400

## Dimension drawings

Foot- and flange-mounted; IM B35 (IM 2001), IM V15 (IM 2011), IM V36 (IM 2031) – terminal box side mounted

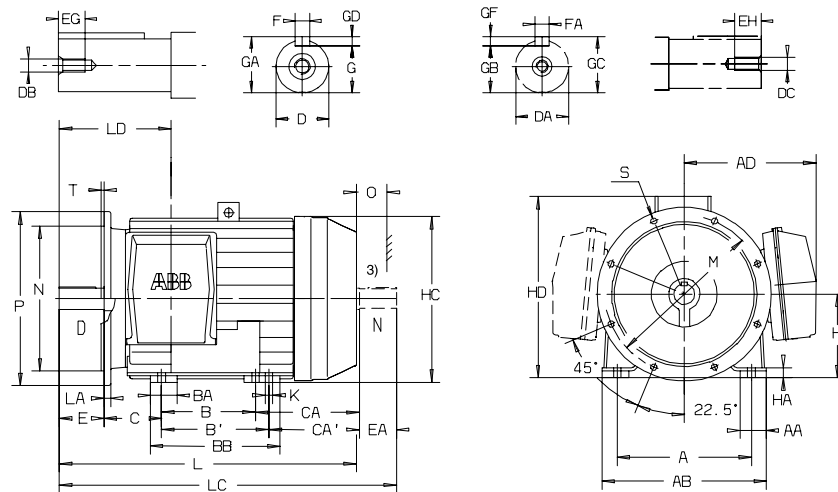

Motor size	Poles <sup>1)</sup>	A	AA	AB	AD	B	B'	BA	BB	C	CA	CA'	D	DA	DB	DC	E	EA	EG	EH	F	FA
355 SA,SB	2	610	110	714	570	500	—	100	584	254	416	—	70	70	M20	M20	140	140	40	40	20	20
	4-8	610	110	714	570	500	—	100	584	254	416	—	100	90	M24	M20	210	170	48	48	28	25
355 MA	2	610	110	714	570	560	—	100	644	254	416	—	70	70	M20	M20	140	140	40	40	20	20
	4-8	610	110	714	570	560	—	100	644	254	416	—	100	90	M24	M24	210	170	48	48	28	25
355 MB	2	610	110	714	570	560	—	100	644	254	416	—	70	70	M20	M20	140	140	40	40	20	20
	4-8	610	110	714	570	560	—	100	644	254	416	—	100	90	M24	M24	210	170	48	48	28	25
355 LA	2	610	110	714	570	630	—	100	765	254	426	—	70	70	M20	M20	140	140	40	40	20	20
	4-8	610	110	714	570	630	—	100	765	254	426	—	100	90	M24	M24	210	170	48	48	28	25
355 LB	2	610	110	714	570	630	—	100	765	254	426	—	70	70	M20	M20	140	140	40	40	20	20
	4-8	610	110	714	570	630	—	100	765	254	426	—	100	90	M24	M24	210	170	48	48	28	25
355 LKD	4-8	610	110	714	570	630	710	100	802	254	583	503	100	90	M24	M24	210	170	48	48	28	25
400 MLA	2	686	140	820	603	630	710	140	850	280	583	503	70	70	M20	M20	140	140	40	40	20	20
	4-8	686	140	820	603	630	710	140	850	280	583	503	100	90	M24	M24	210	170	48	48	28	25
400 MLB	2	686	140	820	603	630	710	140	850	280	583	503	70	70	M20	M20	140	140	40	40	20	20
	4-8	686	140	820	603	630	710	140	850	280	583	503	100	90	M24	M24	210	170	48	48	28	25
400 LKA	2	686	140	820	603	710	800	140	935	280	643	553	80	75	M20	M20	170	140	40	40	22	20
	4-8	686	140	820	603	710	800	140	935	280	643	553	100	90	M24	M24	210	170	48	48	28	25
400 LKB	2	686	140	820	603	710	800	140	935	280	643	553	80	75	M20	M20	170	140	40	40	22	20
	4-8	686	140	820	603	710	800	140	935	280	643	553	100	90	M24	M24	210	170	48	48	28	25

Motor size	Poles <sup>1)</sup>	G	GA	GB	GC	GD	GF	H	HA	HC	HD	K	L	LC	LD	M	N	O	P	S	T
355 SA,SB	2	62.5	74.5	62.5	74.5	12	12	355	36	715	768	28	1310	1460	392	740	680	130	800	23	6
	4-8	90	106	81	95	16	14	355	36	715	768	28	1380	1560	462	740	680	130	800	23	6
355 MA	2	62.5	74.5	62.5	74.5	12	12	355	36	715	768	28	1370	1520	392	740	680	130	800	23	6
	4-8	90	106	81	95	16	14	355	36	715	768	28	1440	1620	462	740	680	130	800	23	6
355 MB	2	62.5	74.5	62.5	74.5	12	12	355	36	715	768	28	1370	1520	392	740	680	130	800	23	6
	4-8	90	106	81	95	16	14	355	36	715	768	28	1440	1620	462	740	680	130	800	23	6
355 LA	2	62.5	74.5	62.5	74.5	12	12	355	36	715	768	28	1450	1600	392	740	680	130	800	23	6
	4-8	90	106	81	95	16	14	355	36	715	768	28	1520	1700	462	740	680	130	800	23	6
355 LB	2	62.5	74.5	62.5	74.5	12	12	355	36	715	768	28	1450	1600	392	740	680	130	800	23	6
	4-8	90	106	81	95	16	14	355	36	715	768	28	1520	1700	462	740	680	130	800	23	6
355 LKD	4-8	90	106	91	95	16	14	355	36	715	768	28	1660	1847	462	740	680	130	800	23	6
400 MLA	2	62.5	74.5	62.5	74.5	12	12	400	45	805	900	35	1616	1773	408	740	680	150	800	23	6
	4-8	90	106	81	95	16	14	400	45	805	900	35	1686	1873	478	740	680	150	800	23	6
400 MLB	2	62.5	74.5	62.5	74.5	12	12	400	45	805	900	35	1616	1773	408	740	680	150	800	23	6
	4-8	90	106	81	95	16	14	400	45	805	900	35	1686	1873	478	740	680	150	800	23	6
400 LKA	2	71	85	67.5	79.5	14	12	400	45	805	900	35	1786	1943	438	740	680	150	800	23	6
	4-8	90	106	81	95	16	14	400	45	805	900	35	1826	2013	478	740	680	150	800	23	6
400 LKB	2	71	85	67.5	79.5	14	12	400	45	805	900	35	1786	1943	438	740	680	150	800	23	6
	4-8	90	106	81	95	16	14	400	45	805	900	35	1826	2013	478	740	680	150	800	23	6

Tolerances:

A, B ISO js14 H ISO 0, -1.0  
 D, DA ISO m6 N ISO j6  
 F, FA ISO h9

<sup>1)</sup> Dimensions for 4-pole motors also valid for 4/6- and 4-8-pole two-speed motors.

<sup>2)</sup> Cooling distance.

<sup>3)</sup> Second shaft end on request.

Above dimensions are in mm.

For detailed drawings please see our web-pages 'www.abb.com/motors&drives' or contact us.

# General purpose steel motors

# Sizes 280-400

## Dimension drawings

### Terminal box in standard design with 6 terminals

#### Top-mounted terminal box:

122/4  
142/4

162/4, 162/9 +  
adapter

#### Side-mounted terminal box:

122/5  
142/6  
162/7, 162/10

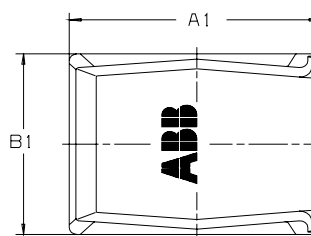
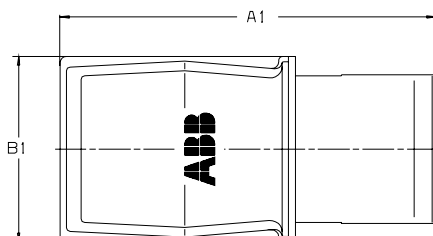
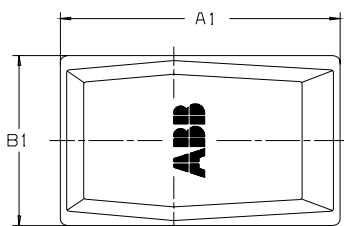
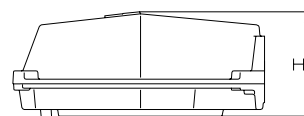
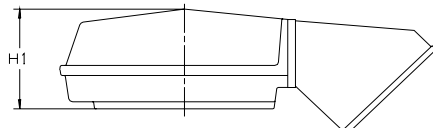
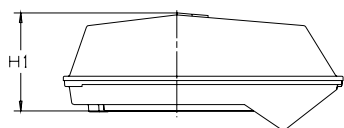

3

Terminal box type	Motor size	A1	B1	H1
-------------------	------------	----	----	----

#### Top-mounted terminal box:

122/4	280	455	280	177
142/4	315 - 400M	536	349	197
162/4 + adapter	355 - 400	787	410	226

#### Side-mounted terminal box:

122/5	280	383	280	180
142/6	315 - 400M	426	347	201
162/7	355 - 400	508	412	226

For motor dimensions please see dimension drawings on earlier pages.

Further details on terminal boxes on previous pages.

## Rating plate

The rating plate is in table form giving values for speed, current and power factor for six voltages.

ABB Oy, Electrical Machines LV Motors, Vaasa, Finland							
CE							
3 ~ Motor M2CA 315 SMA 4 B3							
IEC 315 S/M 80							
						No. 0320-010119452	
						Ins.cl.	F IP 55
V	Hz	kW	r/min	A	cos φ	Duty	
690 Y	50	132	1486	138	0,85	S1	
400 D	50	132	1486	232	0,85	S1	
660 Y	50	132	1485	141	0,86	S1	
380 D	50	132	1485	245	0,86	S1	
415 D	50	132	1487	232	0,84	S1	
440 D	60	150	1784	238	0,87	S1	
Prod.code 3GCA312310-ADA							
						Nmax	r/min
6319/C3		6316/C3				730 kg	
ABB IEC 60034-1							

# Accessories

## Slide rails for motor sizes 280-400

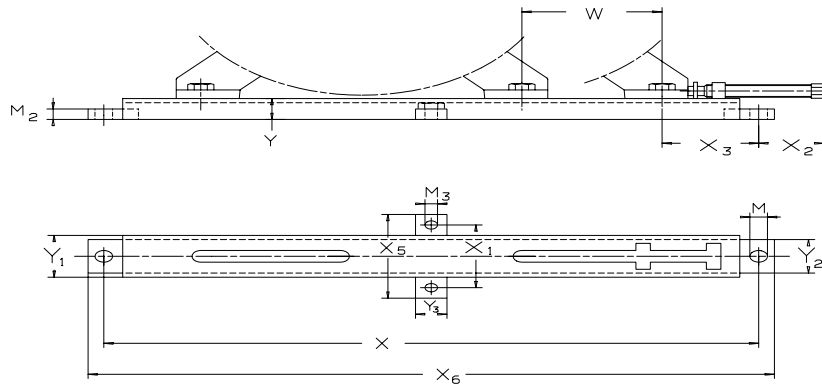

Type	Motor size	M	M <sub>2</sub>	M <sub>3</sub>	W <sub>max</sub>	X	X <sub>1</sub>	X <sub>2</sub> max	X <sub>3</sub> min	X <sub>5</sub>	X <sub>6</sub>	Y	Y <sub>1</sub>	Y <sub>2</sub>	Y <sub>3</sub>	Weight/rail kg
ZHKJ 50	280	28	25	20	135	850	150	125	135	200	900	50	100	80	50	14.5
ZHKJ 63	315	28	25	20	220	1040	150	125	150	200	1090	50	100	80	50	17.5
ZHKJ 71 <sup>1)</sup>	355	33	30	20	275	1260	190	145	185	240	1320	60	140	120	50	31
ZHKJ 71 <sup>1)</sup>	400	33	30	20	180	1260	190	140	200	240	1320	60	140	120	50	31

<sup>1)</sup> When mounting on a ceiling or on a wall please contact the manufacturer.

**Each set includes two complete slide rails including screw for mounting the motor on the rails. Screws for mounting the rails on the foundation are not included. Slide rails are supplied with unmachined lower surfaces and should, prior to tightening down, be supported in a suitable manner.**

## Foundation studs for motor sizes 280-400

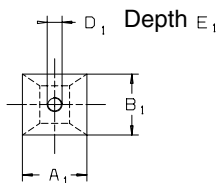
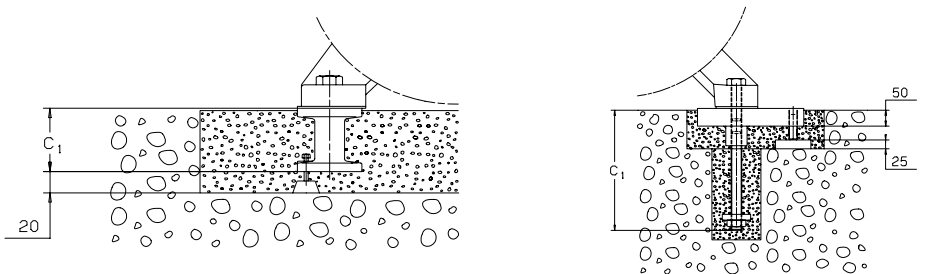

**ZBYH 161...241**

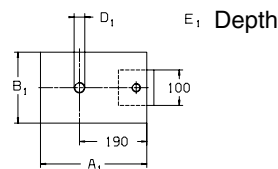

**ZBHE 301**

Foundation stud type	Fixing screw	Motor size	Main dimensions			D1	E1	Weight kg
			A1	B1	C1			
ZBYH 201	M20 x 70/70 Y	280	100	100	95	M20	35	3.4
ZBYH 241	M24 x 90/90 Y	315, 355	130	130	135	M24	45	7
ZBHE 301	M30 x 100/100 Y	400	300	200	385	M30	65	30

**Each set of foundation studs includes 4 studs, fixing screw for the motor, adjusting screw with foundation plate.**

# Accessories

## Protective roof (variant code 005)

Motor size	Poles	Ø	L
280 S_	2	555	1160
	4-12	555	1090
280 SM_	2	555	1160
	4-12	555	1160
280 M_	2	555	1220
	4-12	555	1220
315 S_	2	624	1210
	4-12	624	1240
315 SM_	2	624	1310
	4-12	624	1240
315 M_	2	624	1310
	4-12	624	1340
315 L_	2	624	1380
	4-12	624	1410
355 S_	2	720	1440
	4-12	720	1510
355 M_	2	720	1500
	4-12	720	1570
355 L_	2	720	1580
	4-12	720	1650
355 LK_	4-12	720	1790
400 ML_	2	810	1796
	4-12	810	1836
400 LK_	2	810	1936
	4-12	810	1976

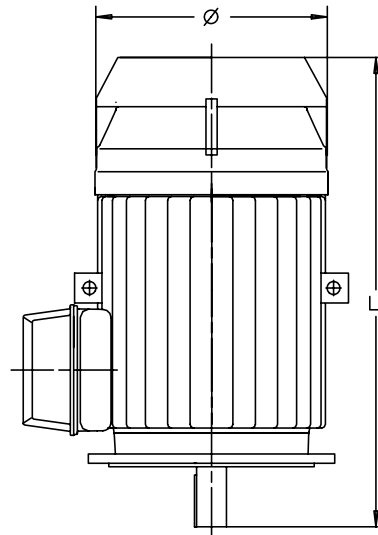

Mounting arrangement IM V1  
with protective roof

## Silencer for motor sizes 280-400

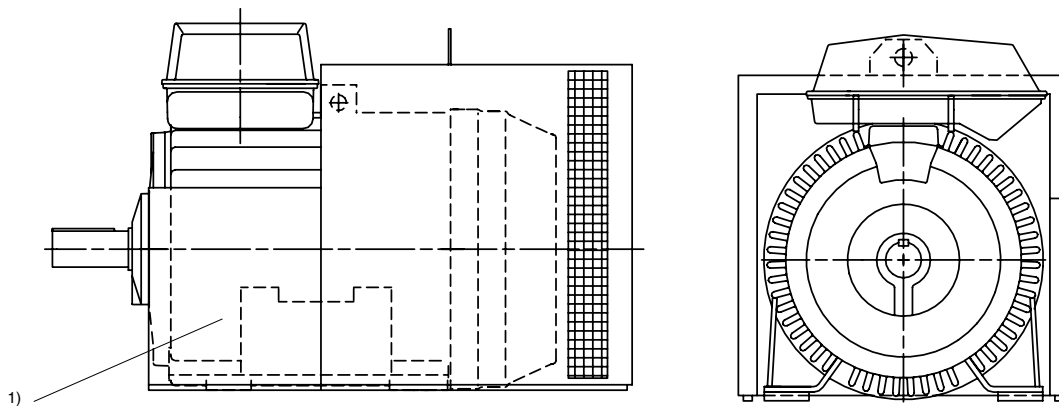

Both foot-mounted and flange-mounted motors can be fitted with a silencer to reduce the noise level by about 10 dB(A). The silencer is painted blue and is made of 2 mm steel sheet. The sound absorbing material is 40 mm thick polyurethane foam. On the underside there is a rubber strip to seal against the floor. The silencer fits loosely over the motor.

**Dimensions of silencers on request.**

<sup>1)</sup> If connections to the motor or control gear require it, an opening can be made in the extension of the silencer or it can be removed.



# General purpose steel motors in brief, basic design

Motor frame size		280	315	355	400
<b>Stator</b>	Material Paint colour shade Paint thickness	Profile-pressed sheet steel Blue, Munsell 8B 4.5/3.25 (NCS 4822-B05G) / RAL 5014 Two-pack epoxy paint, thickness $\geq 70 \mu\text{m}$			
<b>Bearing end shields</b>	Material Paint colour shade Paint thickness	Cast iron EN-GJL-200 or spheroidal graphit EN-GJS-400 Blue, Munsell 8B 4.5/3.25 (NCS 4822-B05G) / RAL 5014 Two-pack epoxy paint, thickness $\geq 70 \mu\text{m}$			
<b>Bearings</b>	D-end      2-pole 4-12 poles	6316/C4 6316/C3	6316/C4 6319/C3	6316M/C4 6322/C3	6317M/C4 6322/C3
	N-end      2-pole 4-12 poles	6316/C4 6316/C3	6316/C4 6316/C3	6316M/C4 6319/C3	6317M/C4 6319/C3
<b>Axially-locked bearings</b>	Inner bearing cover	As standard, locked at D-end			
<b>Bearing seal</b>		V-ring as standard, radial seal on request			
<b>Lubrication</b>		Regreasing nipples, M10x1 Grease for bearing temperatures $-30^{\circ}\text{C}$ to $+120^{\circ}\text{C}$			
<b>SPM-nipples</b>		On request			
<b>Rating plate</b>		Acid proof stainless steel AISI 316, thickness 0.6 mm, with individual serial number			
<b>Terminal box</b>	Frame material Cover material Cover screw material	Cast iron EN-GJL-150 Cast iron EN-GJL-150 Steel 5G, coated with zinc and yellow chromated			
<b>Connections</b>	Cable      2-4 pole entries      6-8 pole	2 x M63 2 x M63	2 x M63 2 x M63	2 x Ø60/80 2 x Ø60	2 x Ø80 2 x Ø60/80
	Terminals	6 terminals for connection with cable lugs (not included)			
<b>Fan</b>	Material	Reinforced glassfiber laminate, aluminium or polypropylene with metal hub			
<b>Fan cover</b>	Material Paint colour shade Paint thickness	Sheet steel Blue, Munsell 8B 4.5/3.25 (NCS 4822-B05G) / RAL 5014 Two-pack epoxy polyester paint, thickness $\geq 80 \mu\text{m}$			
<b>Stator winding</b>	Material Insulation	Copper Insulation class F; temperature rise class B unless otherwise stated.			
	Winding protection	PTC-thermistors $150^{\circ}\text{C}$ , 3 in series, as standard			
<b>Rotor winding</b>	Material	Pressure die-cast aluminium			
<b>Balancing method</b>		Half key balancing as standard			
<b>Key ways</b>		Open key way			
<b>Heating elements</b>	On request	50 W	1 x 65 W	2 x 65 W	2 x 65 W
<b>Drain holes</b>		As standard, open on delivery			
<b>Enclosure</b>		IP 55, higher protection on request			
<b>Cooling method</b>		IC 411			

# ABB Motors' total product offer

ABB offers several comprehensive ranges of AC motors and generators. We manufacture synchronous motors for even the most demanding applications, and a full range of low and high voltage induction motors. Our in-depth knowledge of virtually every type of industrial processing ensures we always specify the best solution for your needs.



## Low voltage motors and generators

### General purpose motors for standard applications

- Aluminum motors
- Steel motors
- Cast iron motors
- Open drip proof motors
- Global motors
- Brake motors
- Single phase motors
- Integral motors

### Process performance motors for more demanding applications

- Aluminum motors
- Cast iron motors
- Motors for high ambient temperatures

### NEMA motors

## High voltage and synchronous motors and generators

- High voltage cast iron motors
- Induction modular motors
- Slip ring motors
- Motors for hazardous areas
- Servomotors
- Synchronous motors and generators
- DC motors and generators

### Motors for hazardous areas

- Flameproof motors
- Increased safety motors
- Non-sparking motors
- Dust ignition proof motors

### Marine motors

- Aluminum motors
- Steel motors
- Cast iron motors
- Open drip proof motors

### Other applications

- Permanent magnet motors
- High speed motors
- Wind turbine generators
- Smoke venting motors
- Water cooled motors
- Motors for roller table drives

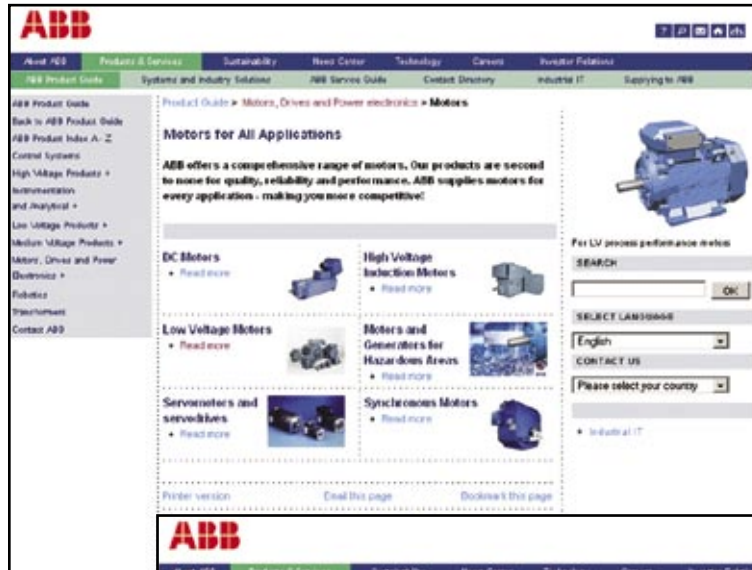

- Motors & Drives**
- => Low Voltage Motors
  - => **General purpose motors**
    - Aluminum motors
    - Steel motors
    - Cast iron motors
    - Global motors
    - Open drip proof motors
    - Brake motors
    - Single phase motors
    - Integral motors
  - Process performance motors
  - Motors for hazardous areas
  - Marine motors
  - Other applications
    - Roller table motors
    - Water cooled motors
    - Permanent magnet motors
    - High speed motors
  - Generators

# Low Voltage Motors

Manufacturing sites (\*) and some of the larger sales companies.

## Australia

ABB Industry Pty Ltd  
2 Douglas Street  
Port Melbourne,  
Victoria, 3207  
Tel: +61 (0) 3 9644 4100  
Fax: +61 (0) 3 9646 9362

## Austria

ABB AG  
Clemens Holzmeisterstrasse 11 B  
AT-1810 Wien  
Tel: +43 (0) 1 601 090  
Fax: +43 (0) 1 601 09 8305

## Belgium

Asea Brown Boveri S.A.-N.V.  
Hoge Wei 27  
BE -1930 Zaventem  
Tel: +32 (0) 2 718 6311  
Fax: +32 (0) 2 718 6657

## Canada

ABB Inc., BA Electrical Machines  
10300 Henri-Bourassa Blvd, West,  
Saint-Laurent, Quebec  
Canada H4S 1N6  
Tel: +1 514 832-6583  
Fax: +1 514 332-0609

## China\*

ABB Shanghai Motors  
Company Limited  
8 Guang Xing Rd., Rong Bei  
Town, Songjiang County,  
Shanghai 201613  
Tel: +86 21 5778 0988  
Fax: +86 21 5778 1364

## Chile

Asea Brown Boveri S.A.  
P.O.Box 581-3  
Santiago  
Tel: +56 (0) 2 5447 100  
Fax: +56 (0) 2 5447 405

## Denmark

ABB A/S  
Automation Technology Electrical  
Machines  
Petersmindevej 1  
DK-5000 Odense C  
Tel: +45 65 477 070  
Fax: +45 65 477 713

## Finland\*

ABB Oy  
LV Motors  
P.O.Box 633  
FI-65101 Vaasa  
Tel: +358 (0) 10 22 11  
Fax: +358 (0) 10 22 47372

## France

ABB Automation  
Rue du Général de Gaulle  
Champagne-sur-Seine  
FR-77811 Moret-sur-Loing Cedex  
Tel: +33 (0) 1 60 746 500  
Fax: +33 (0) 1 60 746 565

## Germany

ABB Automation Products GmbH  
Edisonstrasse 15  
DE-68623 Lampertheim  
Tel: +49 (0) 6206 503 503  
Fax: +49 (0) 6206 503 600

## Hong Kong

ABB (Hong Kong) Ltd.  
Tai Po Industrial Estate,  
3 Dai Hei Street,  
Tai Po, New Territories,  
Hong Kong  
Tel: +852 2929 3838  
Fax: +852 2929 3505

## India\*

ABB Ltd.  
32, Industrial Area, N.I.T  
Faridabad 121 001  
Tel: +91 (0) 129 502 3001  
Fax: +91 (0) 129 502 3006

## Indonesia

PT. ABB Sakti Industri  
JL. Gajah Tunggal Km.1  
Jatiuwung, Tangerang 15136  
Banten, Indonesia  
Tel: + 62 21 590 9955  
Fax: + 62 21 590 0115 - 6

## Ireland

Asea Brown Boveri Ltd  
Components Division  
Belgard Road  
Tallaght, Dublin 24  
Tel: +353 (0) 1 405 7300  
Fax: +353 (0) 1 405 7327

## Italy\*

ABB SACE SpA  
LV Motors  
Via Della Meccanica, 22  
IT-20040 Caponago - MI  
Tel: +39 02 959 6671  
Fax: +39 02 959 667216

## Japan

ABB K.K.  
26-1 Cerulean Tower  
Sakuragaoka-cho, Shibuya-ku  
Tokyo 150-8512  
Tel: +81 (0) 3 578 46251  
Fax: +81 (0) 3 578 46260

## Korea

ABB Korea Ltd.  
7-9fl, Oksan Bldg., 157-33  
Sungshung-dong, Kangnam-ku  
Seoul  
Tel: +82 2 528 2329  
Fax: +82 2 528 2338

## Malaysia

ABB Malaysia Sdn. Bhd.  
Lot 608, Jalan SS 13/1K  
47500 Subang Jaya, Selangor  
Tel: +60 3 5628 4888  
Fax: +60 3 5631 2926

## Mexico

ABB México, S.A. de C.V.  
Apartado Postal 111  
CP 54000 Tlalnepantla  
Edo. de México, México  
Tel: +52 5 328 1400  
Fax: +52 5 390 3720

## The Netherlands

ABB B.V.  
Dept. LV motors (APP2R)  
P.O.Box 301  
NL-3000 AH Rotterdam  
Tel: +31 (0) 10 4078 879  
Fax: +31 (0) 10 4078 345

## Norway

ABB AS  
P.O.Box 154 Vollebakk  
NO-0520 Oslo  
Tel: +47 22 872 000  
Fax: +47 22 872 541

## Singapore

ABB Industry Pte Ltd  
2 Ayer Rajah Crescent  
Singapore 139935  
Tel: +65 6776 5711  
Fax: +65 6778 0222

## Spain\*

ABB Automation Products S.A.  
Division Motores  
P.O.Box 81  
ES-08200 Sabadell  
Tel: +34 93 728 8500  
Fax: +34 93 728 8741

## Sweden\*

ABB Automation Technologies AB  
LV Motors  
SE-721 70 Västerås  
Tel: +46 (0) 21 329 000  
Fax: +46 (0) 21 329 140

## Switzerland

ABB Schweiz AG  
Normelec  
Badenerstrasse 790  
Postfach  
CH-8048 Zürich  
Tel: +41 (0) 58 586 0000  
Fax: +41 (0) 58 586 0603

## Taiwan

ABB Ltd.  
6F, No. 126, Nanking East Road,  
Section 4i  
Taipei, 105 Taiwan, R.O.C.  
Tel: +886 (0) 2 2577 6090  
Fax: +886 (0) 2 2577 9467

## Thailand

ABB Limited (Thailand)  
161/1 SG Tower,  
Soi Mahadlekluang 3,  
Rajdamri, Bangkok 10330  
Tel: +66 2 665 1000  
Fax: +66 2 665 1042

## The United Kingdom

ABB Automation Ltd  
9 The Towers, Wilmslow Road  
Didsbury  
Manchester, M20 2AB  
Tel: +44 (0) 161 445 5555  
Fax: +44 (0) 161 448 1016

## USA

ABB Inc.  
Low Voltage Motors  
16250 W. Glendale Drive  
New Berlin, WI 53151  
Tel: +1 262 785 3200  
Fax: +1 262 785 8628

## Venezuela

Asea Brown Boveri S.A.  
P.O.Box 6649  
Carmelitas,  
Caracas 1010A  
Tel: +58 (0) 2 238 2422  
Fax: +58 (0) 2 239 6383



<http://www.abb.com/motors&drives>  
<http://online.abb.com/motors&drives>