

MNS *iS* Motor Control Center
MControl Interface Manual Profibus Direct
System Release V7.6



MNS is a registered trademark.

Emax, Tmax are registered trademarks of ABB SACE Spa.

Microsoft, Windows and Windows XP are registered trademarks of Microsoft Corporation.

JAVA is a registered trademark from Sun Microsystems.

Product names of other products are registered trademarks of their manufacturers or owners.

This document relates to the MNS iS System Release 7.6/0.

The information in this document is subject to change without notice and should not be construed as a commitment by ABB. ABB assumes no responsibility for any errors that may appear in this document.

In no event shall ABB be liable for direct, indirect, special, incidental, or consequential damages of any nature or kind arising from the use of this document, nor shall ABB be liable for incidental or consequential damages arising from use of any software or hardware described in this document.

This document and parts thereof must not be reproduced or copied without ABB's written permission, and the contents thereof must not be imparted to a third party nor be used for any unauthorized purpose. The software described in this document is furnished under a license and may be used, copied, or disclosed only in accordance with the terms of such license.

All rights reserved.

Copyright © 2015 ABB Automation Products GmbH, Ladenburg, Germany

Table of content

- General 4**
 - Target Group 4
 - Use of Warning, Caution, Information and Tip Icon..... 4
 - Terminology 5
 - Related Documentation..... 9
 - Related System Version..... 9
 - Document Revision History 10

- Introduction..... 11**
 - Profibus Standard 11
 - MNS iS Hardware Requirements..... 11
 - MNS iS Software Requirements 11

- Basics 12**
 - PROFIBUS DP-V0 12
 - Cyclic Data Communication..... 12
 - Diagnostics 12
 - PROFIBUS DP-V1 14
 - Acyclic Data Communication 14

- Interfaces..... 15**
 - MControl Profibus connector 15
 - Connection 15
 - Termination..... 16

- Getting Started..... 18**
 - Configuration parameters..... 18
 - Parameters 18
 - Addressing..... 19
 - Failsafe..... 20
 - Control Access..... 21

- PROFIBUS Data Mapping..... 22**
 - General..... 22
 - Monitoring data 23
 - Quality Code 30
 - MControl status..... 33
 - Starter dependent information 34
 - Command format 35

General

Target Group

This document describes communication and control interfaces used in MNS *iS*.

The manual is primarily intended for those requiring information on accessing information and data provided from MNS *iS*. Furthermore the document provides information for integration of MNS *iS* as Fieldbus component into PLC or higher level Process Control Systems to control system and application engineers.

It is assumed that the reader of this manual is familiar with basic terms of Fieldbus and control communication (e.g. basic knowledge about PROFIBUS, Modbus etc.).

Use of Warning, Caution, Information and Tip Icon

This publication includes **Warning**, **Caution**, and **Information** icons where appropriate to point out safety related or other important information. It also includes **Tip** icons to point out useful hints to the reader. The corresponding symbols should be interpreted as follows:



The electrical warning icon indicates the presence of a hazard that could result in *electrical shock*.



The warning icon indicates the presence of a hazard that could result in *personal injury*.



The caution icon indicates important information or warnings related to the concept discussed in the text. It might indicate the presence of a hazard that could result in *corruption of software or damage to equipment/property*.



The information icon alerts the reader to pertinent facts and conditions.



The tip icon indicates advice on, for example, how to design your project or how to use a certain function

Although **Warning** notices are related to personal injury, and **Caution** notices are associated with equipment or property damage, it should be understood that the operation of damaged equipment could, under certain operational conditions, result in impaired process performance leading to personal injury or death. It is, therefore, imperative that you comply fully with all **Warning** and **Caution** notices.

Terminology

List of the terms, acronyms, abbreviations and definitions that the document uses.

Abbreviation	Term	Description
	Aspect Object	ABB technology. An Aspect Object is a computer representation of a real object such as a pump, a valve, an order or a virtual object such as a service or an object type. An Aspect Object is described by its aspects and is organized in structures.
	Alarm	Alarm is defined as status transition from any state to abnormal state. Status transition to abnormal state can be data crossing over the pre-defined alarm limit.
	Bus Local	A Control Access term describing that the MControl accepts its commands from a device on the switchgear control network, e.g. the Web Interface, MView.
COTS	Commercial off the shelf	Commercial off the shelf product, term to describe products available on the market, ready to use
DCS	Distributed Control System	See also PCS
DTM	Device Type Manager	Software module used to manage devices via Fieldbus (e.g. PROFIBUS) using frame application environment (e.g. PactWare, ABB Fieldbus Builder etc.)
Eth.	Ethernet	Ethernet is a local area network (LAN) technology. The Ethernet standard specifies the physical medium, access control rules and the message frames.
	Event	An event is a status transition from one state to another. It can be defined as alarm, if the state is defined as abnormal or as warning as a pre-alarm state.
FD	Field Device	Term for devices connected to the Fieldbus (e.g. motor control units or circuit breaker protection)
GSD file	Geräte Stamm Datei (German abbreviation)	A hardware description file for a PROFIBUS-DP or PROFIBUS-DP/V1 slave type
GPS	Global Positioning System	System to detect local position, universal time and time zone, GPS technology provides accurate time to a system

Abbreviation	Term	Description
	Hardware Local	A Control Access term describing that the <i>MControl</i> accepts its commands from the Hardwired inputs, when the respective Local control input is set to true.
HMI	Human Machine Interface	Generic expression
LVS	Low voltage switchgear	A factory built assembly built to conform with IEC 60439-1
MCC	Motor Control Centre	Common term for switchgear used for motor control and protection.
MNS		Modular Low Voltage Switchgear family from ABB
MNS <i>iS</i>		The integrated intelligent switchgear solution from ABB
	<i>MStart</i> <i>MFeed</i> <i>MControl</i> <i>MLink</i> <i>MView</i> <i>MNavigate</i>	MNS <i>iS</i> components integrated in the switchgear, see the MNS <i>iS</i> System Guide for technical details
	MODBUS	Fieldbus communication protocol
	MODBUS RTU	Fieldbus communication protocol
	Motor Starter	Consists of motor controller and electrical components to control and protect a motor, part of Motor Control Center
NLS	Native Language Support	Providing the ability to change the language of software tools in order to support native languages (English is basis, others are optional)
OPC		OLE for Process Control, an industrial standard for exchange of information between components and process control application
PCS	Process Control System	High level process control system
PLC	Programmable Local Controller	Low level control unit

Abbreviation	Term	Description
	PROFIBUS-DP	Fieldbus communication protocol with cyclic data transfer (V0).
	PROFIBUS-DP/V1	Fieldbus communication protocol, extension of PROFIBUS- DP allowing acyclic data transfer and multi master (V1).
	PROFIBUS-DP/V2	Fieldbus communication protocol, extension of PROFIBUS- DP allowing time stamp and communication between master and slave (V2).
	PROFINET	PROFINET is an open standard for Industrial Ethernet and standardized in IEC 61158 and IEC 61784.
PNIO	PROFINET IO	PROFINET for decentralized periphery and distributed automation
RCU	Remote Control Unit	Local control unit with pushbutton and indicator to operate a device (e.g. motor) from field level.
RS232		Standard No. 232 for PC communication, established by EIA (Electronics Industries Association, USA)
RS485		Communication interface standard from EIA (Electronics Industries Association, USA), operating on voltages between 0V and +5V. RS-485 is more noise resistant than RS-232C, handles data transmission over longer distances, and can drive more receivers.
RTC	Real Time Clock	Integrated clock function in devices used to generate time and date information if a remote clock system is not present
	Software Local	A Control Access term describing that the MControl accepts its commands from the hardwired inputs as a result of either the PCS or MView passing the Control Access Authority to Soft-Local. Note: Does not require the hardwired local input to be set to true.
SNTP	Simple Network Time Protocol	a protocol used for time synchronization in Control Network through Ethernet
	Switchgear Bus Network	Term used to describe the internal switchgear communication network, between MLink and MControl.
TCP/IP	Transmission Control Protocol / Internet Protocol	TCP/IP is a high-level connection oriented, reliable, full duplex communication protocol developed for integration of the heterogenous systems.

Abbreviation	Term	Description
	Trip	A consequence of an alarm activated or an external trip command from another device to stop the motor or trip the circuit breaker.
UTC	Coordinated Universal Time	Coordinated Universal Time is the international time standard. It is the current term for what was commonly referred to as Greenwich Meridian Time (GMT). Zero (0) hours UTC is midnight in Greenwich England, which lies on the zero longitudinal meridian. Universal time is based on a 24 hour clock.
	Warning	A warning is defined as status transition from any state to pre-alarm state to inform in advance before an alarm level is reached.

Related Documentation

MNS *iS*

1TGC910211 M0203 MNS *iS* Interface Manual *MLink*, Release 7.0
1TGC910111 M0203 MNS *iS* *MLink* Upgrade Kit Manual
1TGC910224 M0201 MNS *iS* Interface Manual Web Interface, Release 8.1
1TGC910232 M0201 MNS *iS* Interface Manual OPC Server 7.0, Release 7.7
1TGC910241 M0202 MNS *iS* Interface Manual Profibus, Release 7.0
1TGC910251 M0202 MNS *iS* Interface Manual Modbus, Release 7.0
1TGC910292 M0201 MNS *iS* Interface Manual PROFINET IO, Release 7.6
1TGC910261 M0202 MNS *iS* Interface Manual Redundancy, Release 7.0
1TGC910272 M0201 MNS *iS* Interface Manual *MConnect*, Release 7.6
1TGC910001 B0204 MNS *iS* System Guide
1TGC910201 M0201 MNS *iS* Quick Guide Installation and System Setup, Release 7.0
1TGC910090 M0211 *MNavigate* Help file V8.1
1TGC910018 M0208 MNS *iS* ATEX – Enhancements for Safety

Profibus

- [1] PROFIBUS Installation Guideline, Rev 4, Nov 2002, Profibus Competence Center Manchester, UK
- [2] PROFIBUS Profiles for Low Voltage Switchgear Devices (LVSG), 3.122 Version 1.2 July 2006, PNO Karlsruhe, Germany
- [3] PROFIBUS Installation Guideline for Cabling and Assembly, 8.022 Version 1.0.6 May 2006, PNO Karlsruhe, Germany
- [4] PROFIBUS Installation Guideline for Commissioning 8.032 Version 1.0.2 November 2006, PNO Karlsruhe, Germany
- [5] PROFIBUS Technology Description 4.002 Version October 2002, PNO Karlsruhe, Germany

Related System Version

The content of this document is related to MNS *iS* System Release 7.6/0.

Document Revision History

Rev.	Page	Chapter	Description of change	Date
M0201			Initial document for Release V7.6	December 2014
M0202	9	Related Documentation	List of documents updated	September 2015
	25	Monitoring data	Reference to <i>MControl</i> base version 5.4 removed	

Introduction

Profibus Standard

PROFIBUS is a manufacturer-independent Fieldbus standard for applications in manufacturing, process and building automation. PROFIBUS technology is described in fixed terms in DIN 19245 as a German standard and in EN 50170 / IEC 61158 as an international standard. The PROFIBUS standard is thus available to every provider of automation product.

The PROFIBUS family is composed of three types of protocol, each of which is used for different tasks. Of course, devices with all three protocols can communicate with each other in a complex system by means of a PROFIBUS network.

The three types of protocols are: PROFIBUS FMS, DP and PA. Only the two protocol types DP and PA are important for process automation, whereas only DP is used in MNS iS. See also reference document [5].

PROFIBUS DP: the **process Fieldbus** for the **decentralized periphery**

The PROFIBUS DP (RS 485) is responsible for communication between the Controller level of a process automation system and the decentralized periphery in the field. One feature of PROFIBUS DP is its high speed of transmission up to 12 Mbit/s.

MNS iS Hardware Requirements

MControl with Profibus Direct communications interface

1TGE120011R2xxx

MNS iS Software Requirements

For full support of the MNS iS V7.6 functionality the Profibus interface requires

- *MControl* base version 7.6 or higher
- GSD file version : **ABB_0C43.GSD**
(file available via local ABB Low Voltage Systems unit)

Basics

PROFIBUS DP-V0

Cyclic Data Communication

The data communication between the DPM1 (DP Master Class 1) and its assigned slaves is automatically handled by the DPM1 in a defined, recurring sequence. With each user data transfer, the master can write up to 244 bytes of output data to the slave and read up to 244 bytes of input data from the slave. The Data is read and written synchronously in one procedure.

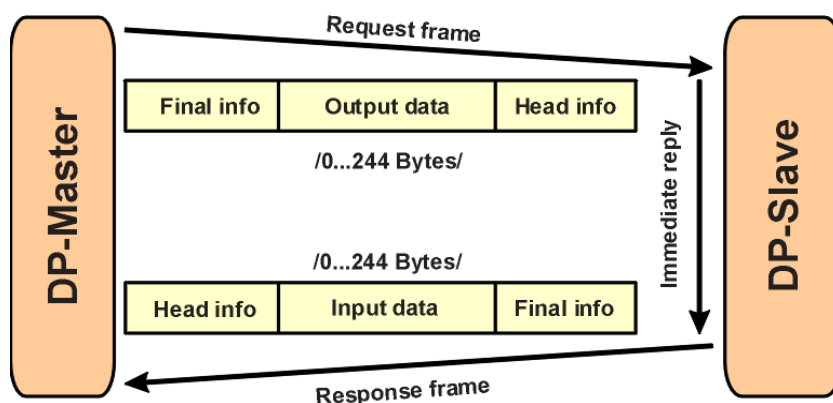

Fig. 1 Cyclic User Data Transmission in DP

The data communication between the DPM1 and the slaves is divided into three phases: parameterization, configuration and data transfer. Before the master includes a DP slave in the data transfer phase, a check is run during the parameterization and configuration phase to ensure that the configured set point configuration matches the actual device configuration. During this check, the device type, format and length information and the number of inputs and outputs must also correspond. This provides you with reliable protection against parameterization errors.

Diagnostics

In addition to the cyclic data the PROFIBUS slave unit provides diagnostic data. With this diagnostic data the slave can indicate errors or warnings on the slave unit, the I/O-units or the I/O-channels. Some diagnostic data is generic and defined by the PNO. But most of the diagnostic data is manufacturer specific.

An example for generic diagnosis is: Slave not ready, Parameter fault and Watchdog monitoring.



MControl supports only generic diagnostic. Extended (manufacturer specific) diagnostic is not supported at the moment.

Sync and Freeze Mode

In addition to the normal cyclic communication between the DPM1 (DP Master Class 1) and the assigned slaves, a master can send the control commands sync and freeze via multicast to a group of slaves.

With the sync-command the addressed slaves will freeze the outputs in their current state. New output values received by the master will be stored while the output states remain unchanged. The stored output data are not sent to the outputs until the next sync command is received. The Sync mode is terminated with the “unsync” command.

In the same way, a freeze command causes the addressed slaves to enter freeze mode. In this mode, the states of the inputs are frozen at their current value. The input data are not updated again until the master sends the next freeze command. Freeze mode is terminated with the “unfreeze” command



MControl does not support Sync Mode and Freeze Mode.

DP Master Class 1 (DPM1) and Class 2 (DPM2)

The DP master class 1 is the master that is in cyclic data transmission with the assigned slaves. To get into the cyclic communication the DPM1 has to configure the slave before.

The DP master class 2 is used for engineering and configuration. It does not have cyclic data transmission with the slave devices. Normally a DPM2 is only connected temporarily to the bus. A DPM2 can have class 2 communication to the slave devices before the slaves are configured via DPM1 and cyclic communication is active.



MControl supports DPM1 communication only.

Monitoring the DP-V0 Communication

The cyclic communication between the DPM1 and the slaves is monitored by the master and the slaves itself. If the DPM master unit detects a failure in the communication with a slave, it will indicate the corresponding slave as disturbed.

On slave side the communication with the master is controlled via the watchdog. If no data communication with the master occurs within the watchdog control interval, the slave automatically switches its outputs to the fail-safe state.



PROFIBUS watchdog must be enabled in the Master (DCS Controller) and failsafe functionality must be parameterized for *MControl*.

PROFIBUS DP-V1

Acyclic Data Communication

The key feature of version DP-V1 is the extended function for acyclic data communication. The acyclic data communication is mainly used for configuration and parameterization purpose. With the acyclic DP-V1 read and write services the master can read or write any desired data to and from the slave. The data is addressed by slot, index and length. Each data block can be up to 244 bytes.

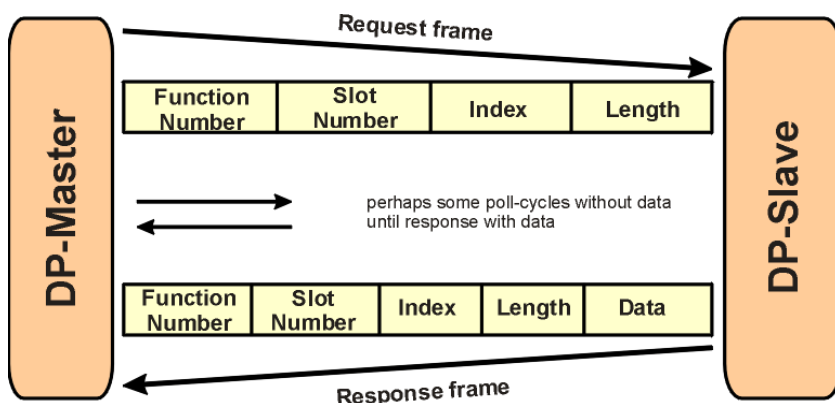

Fig. 2 Acyclic Communication in DP-V1: Read Service

The transmission of acyclic data is executed in parallel to the cyclic data communication, but with lower priority. Acyclic services are operated in the remaining time at the end of the DP-V0 cycle.



MControl Profibus Direct Interface supports DPV1 communication. However, currently only cyclic data exchange is available.

Interfaces

MControl Profibus connector

Each MControl can be connected to the Profibus network via a connector on the front side of the MControl. MControl acts as a standard PROFIBUS-DP Slave device.

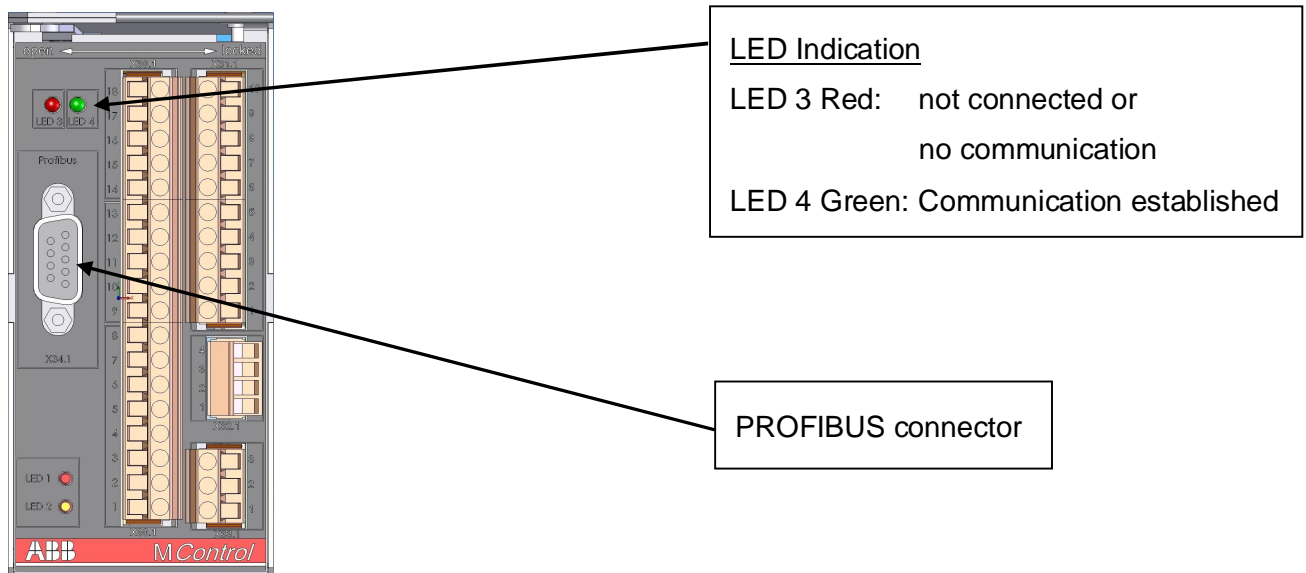

Fig. 3 MControl front view with PROFIBUS connector

Connection

The physical medium for PROFIBUS-DP is RS-485, which allows 32 nodes in a single segment and 125 nodes in a network using 4 segments. Segments must be separated by using Repeater.

The PROFIBUS interface checks input signal for poll requests from master and detects the baud rate automatically (max Baud Rate = 12MBit).

Cable length may vary from 80-1200 m depending on transmission speed and repeater type in use. Cable length can be extended using fiber optic modems (yielding a more robust network). See reference document [4] for more details on cable connections and wiring.

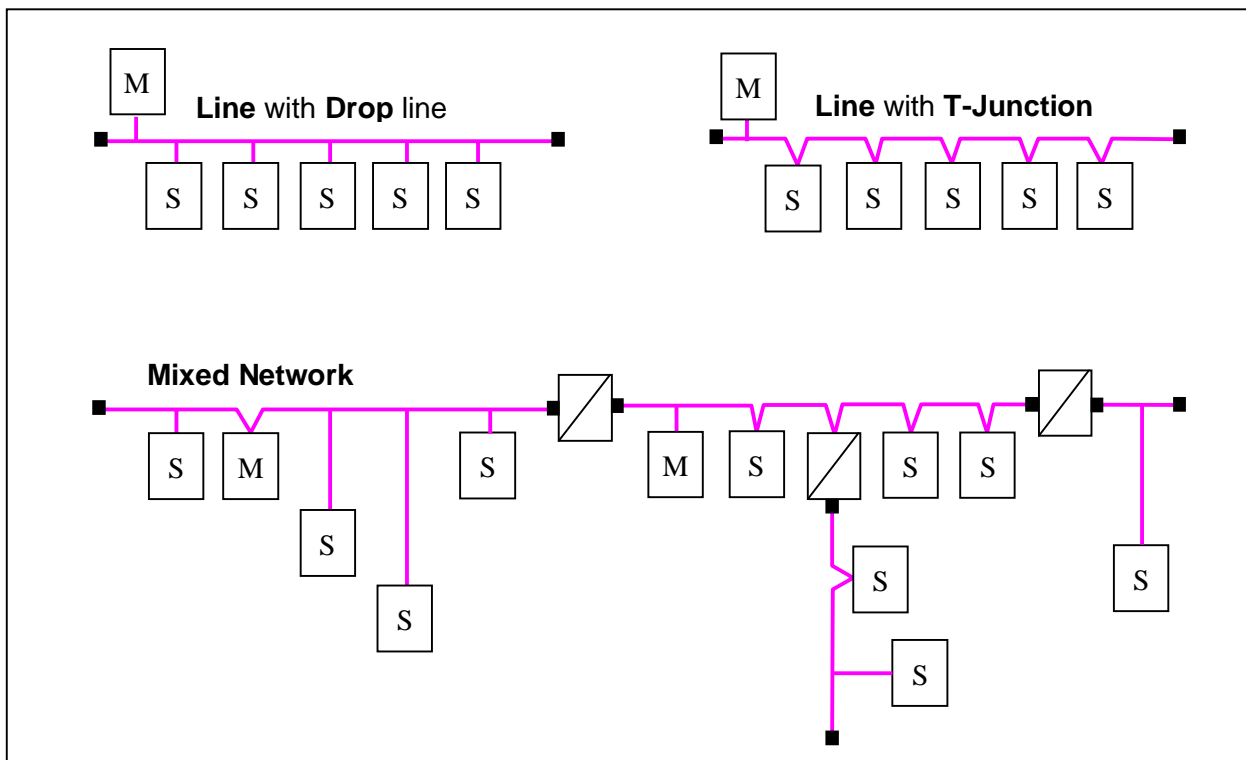

Fig. 4 PROFIBUS network principles (M – Master, S –Slave)

The connection on *MControl* is done via PROFIBUS Standard Sub-D plugs. This provides a T-Junction with up to 12 Mbaud communication speed. At both ends of a segment a termination must be activated. This termination can either be part of the PROFIBUS connector or a separate type.



In a mixed network, the maximum cable length of drop lines must be considered. This is very important especially for higher communication Baud rates !

See reference documents [1] & [3] for more information.

Termination

The *MControl* does not provide PROFIBUS Termination in-built. Therefore correct measures have to be taken to connect termination to both ends of the PROFIBUS segment.



It is recommended to use PROFIBUS standard plugs with Termination inbuilt. In addition it is good practice to use Active Termination devices at the end of a Segment.

Connection and termination examples

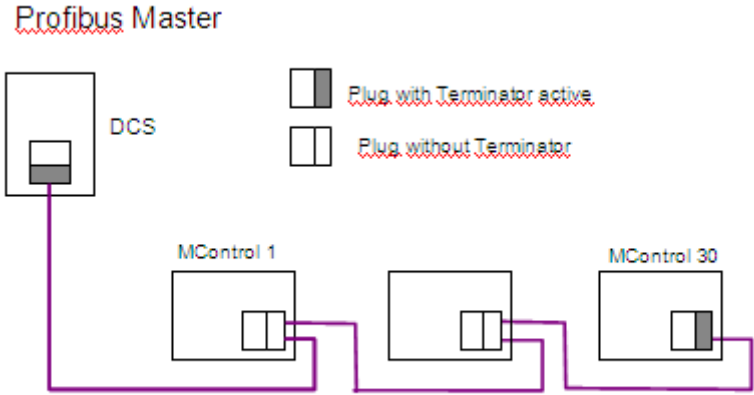

Fig. 5 MControl PROFIBUS connection and termination example

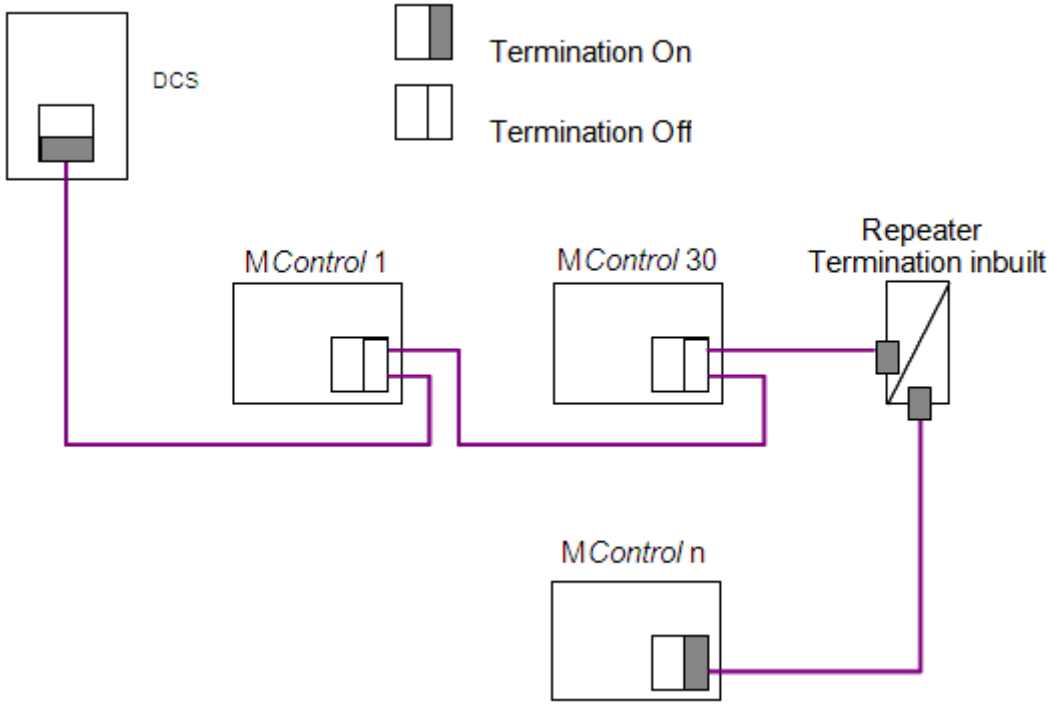

Fig. 6 MLink PROFIBUS connection and termination example with Repeater

Getting Started

MControl requires Profibus module to be selected when editing the firmware. For the Profibus module there are few parameters to be set:

Configuration parameters

Parameter	Default Value	Range	Remarks
Profibus Address	126	3 ...126	PROFIBUS station address <ul style="list-style-type: none"> • 0,1,2 reserved for DP Master • 126, 127 reserved
PB-Direct GPI1 PB-Direct GPI 2 PB-Direct GPI 3 PB-Direct GPI 4	False	Binary inputs	The values of these binary inputs can be monitored via Profibus. PB-Direct GPI1-4 assignment configured in MNavigate tool.

Parameters

Parameter	Default Value	Range	Remarks
Control Access Owner	Restore	Restore Soft Local Bus Local Remote	This selects the Control Access (CA) owner, when the AutoMode Bit is cleared or Profibus communication stops. “ Restore ” means that the CA owner returns to previous latest selected CA state

Table 1 MControl PROFIBUS parameter and initial values

Addressing

PROFIBUS-DP allows the address range of 0 to 127. Following reservations apply:

- 0, 1, 2 - used for PROFIBUS Master
- 126, 127 - reserved

The remaining address numbers are available. It must be ensured that the number selected is unique for the PROFIBUS Master where the MControl is connected to. Using a number more than once will cause communication error on PROFIBUS.



MControl does not support address setting / changing from PROFIBUS Master. The address must be defined with the configuration parameter in MNavigate and settings must be downloaded into MControl.

If more than 32 devices are connected to a segment, repeater devices have to be used. Such repeater counts as one Slave within a segment without using an address number. Thus only 30 Slaves are possible within a segment.

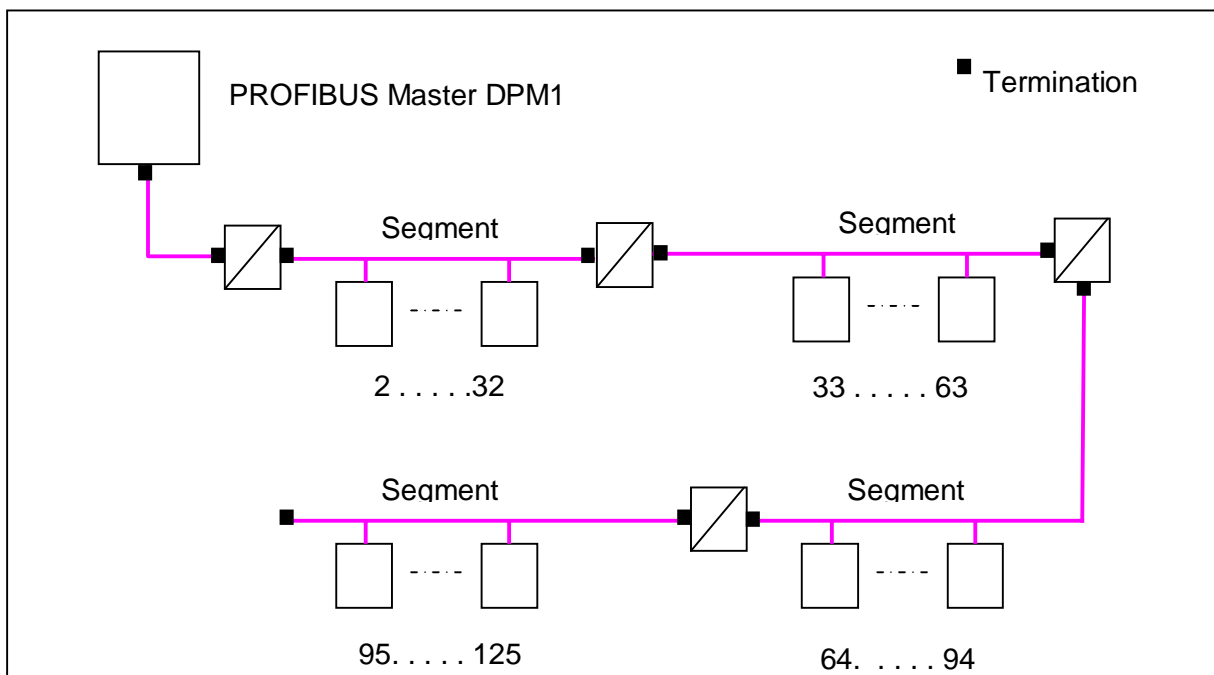

Fig. 7 Example of max address range and slave numbers on one PROFIBUS Master

Failsafe

In case of a disturbed PROFIBUS communication an option is available to transfer all *MControl* modules into a safe state. This *MStart* specific failsafe state has to be defined as a *MControl* starter parameter (utilizing *MNavigate*).

The DCS / PLC has to set the “Activate Failsafe” bit and “AutoMode” bit if Failsafe shall be generated whenever the Profibus communication to *MControl* stops or fails.

Profibus telegram bit		Action when Profibus communication to <i>MControl</i> stops or fails
“Activate Failsafe”	“AutoMode”	
Cleared (0)		No failsafe generated and failsafe action will not be executed
	Cleared (0)	No failsafe generated and failsafe action will not be executed
Set (1)	Set (1)	If no second Failsafe Master (e.g. MLink connected to DCS acting as second Failsafe Master) for that <i>MControl</i> is available then <i>MControl</i> will execute configured Failsafe action (configured in <i>MNavigate</i>) in case of communication loss to connected DCS/PLC.



To disconnect without activating Failsafe the PLC must clear “Activate Failsafe” or “Auto Mode” before stopping the communication.

Control Access

To request control via Profibus Direct the "AutoMode" bit must be set in the control structure:

- If the Hardware Local input is active the control will stay with the local inputs and the AutoMode bit inside the monitoring data will not be set.
- If the Hardware Local input is not active the MControl will accept the request and set the AutoMode bit in the monitoring data. Also the "CA MControl Fieldbus Interface" bit in the CA section of the MControl status is set. Then the MControl will follow the Profibus requests.

When clearing the AutoMode bit the control access owner will be set as specified in the setting of the MNavigate Parameter "Control Access Owner" (see Parameter table above) for the MControl Profibus Interface.



To enable the control via MView, Gateways, RCU, etc. the AutoMode bit of the Profibus Direct interface must be cleared.

PROFIBUS Data Mapping**General**

MControl supports

- the 2 PNO Standard Profibus profiles for Low Voltage Switchgear (Motor Management Starter Profile)
- a MControl proprietary full information profile

Profile type	Monitoring data format	Command format	Remark
4read – 2write	0	0	Standard PNO profile Low Voltage Switchgear
4read – 4write	0	1	Standard PNO profile Low Voltage Switchgear
4read – 13write	0	2	<u>Monitoring:</u> Standard PNO profile Low Voltage Switchgear <u>Commands:</u> MControl proprietary
244 read – 13 write	2	2	<u>Monitoring:</u> MControl proprietary <u>Commands:</u> MControl proprietary

The standard profiles are based on the technical specification “Profiles for Low Voltage Switchgear, Version 1.2, July 2006).

Monitoring data

**Monitoring data based on PROFIBUS Profile
for Low Voltage Switchgear/ Motor Management Starter Profile**

Format 0

Byte	Bit7	Bit6	Bit5	Bit4	Bit3	Bit2	Bit1	Bit0
0	Warning	Fault	Auto Mode	Lock-Out Time	Overload Warning	Status		
1	Failsafe	Ready	Test	Trip reset possible	Reserved (PB-Direct GPI4)	Reserved (PB-Direct GPI3)	Reserved (PB-Direct GPI2)	Reserved (PB-Direct GPI1)
2	Motor current highest phase – high [% / In]							
3	Motor current highest phase – low [% / In]							

The reserved Bits of Byte 1 may be used for some GPI, which can be connected to the Profibus interface. This enables the user to pick some status information beyond the three starter dependent status bits. The different bits are handled as follows.

Description of Information available from profiles

Profibus Byte/Bit	Function		
Byte0 / Bit7	Warning	0 = no warning	1 = any warning of the available protection and supervision functions
Byte0 / Bit6	Fault	0 = no trip condition	1 = any trip condition of the available protection and supervision functions
Byte0 / Bit5	Auto Mode	0 = not in AutoMode the <i>Control</i> bits are ignored	1 = AutoMode, the <i>MControl</i> follows the Profibus requests
Byte0 / Bit4	Lock-Out	0 = <i>MControl</i> can be started	1 = <i>MControl</i> start is locked out by Thermal overload, start inhibit, etc.
Byte0 / Bit3	Overload Warning	0 = no Thermal Overload Warning (TOL) pending	1 = Thermal Overload Warning; set level for TOL is reached .
Byte0 / Bit2	Status	Starter dependent information	
Byte0 / Bit1			
Byte0 / Bit0			

Profibus Byte/Bit	Function		
Byte1 / Bit7	Failsafe	0 = MControl is in normal state	1 = Failsafe condition happened
Byte1 / Bit6	Ready	0 = not ready to start	1 = ready to start = MStart connected & main switch on & no trip & no start inhibit
Byte1 / Bit5	Test	0 = MStart not in test position	1 = MStart in test position; Main switch off but contactor control possible
Byte1 / Bit4	Trip Reset possible	0 = Trip reset not possible	1 = Trip reset possible
Byte1 / Bit3	PB-Direct GPI4	0 = GPI 4 not active	1 = GPI 4 is active
Byte1 / Bit2	PB-Direct GPI3	0 = GPI 3 not active	1 = GPI 3 is active
Byte1 / Bit1	PB-Direct GPI2	0 = GPI 2 not active	1 = GPI 2 is active
Byte1 / Bit0	PB-Direct GPI1	0 = GPI 1 not active	1 = GPI 1 is active

Starter dependent status bits description:

Starter type	Bit 2	Bit 1	Bit 0
NR-DOL / NR-DOL-RCU	Runs	Off	Reserved (=0)
REV-DOL / REV-DOL-RCU	Runs forward	Off	Runs reverse
NR-DOL Star/Delta ⁽¹⁾	Runs	Off	Reserved (=0)
NoStarter	Runs forward	Off	Runs reverse
NR-DOL Softstarter ⁽²⁾	Runs	Off	Reserved (=0)
Transparent	K3	K2	K1
Transparent with Control	Reserved (=0)	Reserved (=0)	K1 (Open/Close)
Transparent without Control	Reserved (=0)	Reserved (=0)	Reserved (=0)
Actuator ⁽³⁾	Opening	Stopped	Closing
Feeder	Closed	Opened	Reserved (=0)
Feeder DC/1phase-AC	Closed	Opened	Reserved (=0)
C-Feeder	Closed	Opened	Reserved (=0)
C-Feeder RCU	Closed	Opened	Reserved (=0)



(1) Star/Delta information has to be read via GPI if required

(2) Softstart/Softstop information has to be read via GPI if required.

(3) Actuator opened/closed has to be read via GPI if required

Format 2

This format delivers the full information as displayed on the MView.

Note :

- **All values are indicated in Motorola Byte order !
(e.g. Unsigned32 : HH-Byte / H-Byte / L-Byte / LL-Byte)**

Profibus Byte offset	Bit offset	Data type	Description
0	0	Unsigned32	QualityCode1: Bit field with bits indicating whether measurement values are valid. <i>See tables below !</i>
4	0	Unsigned32	QualityCode2: Bit field with bits indicating whether measurement values are valid. <i>See tables below !</i>
8	0	Unsigned32	MControl status <i>See tables below !</i>
12	0	Floating point	Current Phase L1 [A]
16	0	Floating point	Current Phase L2 [A]
20	0	Floating point	Current Phase L3 [A]
24	0	Unsigned16	Current Phase L1 [%]
26	0	Unsigned16	Current Phase L2 [%]
28	0	Unsigned16	Current Phase L3 [%]
30	0	Floating point	Earth fault current IO [A].
34	0	Floating point	Phase Voltage U12 [V], Phase 1 Voltage [V] (for single phase systems)
38	0	Floating point	Phase Voltage U23 [V]
42	0	Floating point	Phase Voltage U31 [V]
46	0	Floating point	Cos Phi (calculated)
50	0	Floating point	Frequency [Hz]
54	0	Floating point	Apparent Power [kVA]
58	0	Floating point	Active Power [kW]
62	0	Floating point	Reactive Power [kVAR]
66	0	Floating point	Contact Temperature L1[°C]
70	0	Floating point	Contact Temperature L2 [°C]
74	0	Floating point	Contact Temperature L3 [°C]
78	0	Unsigned32	Contactactor Switching Cycles K1
82	0	Unsigned32	Contactactor Switching Cycles K2
86	0	Unsigned32	Contactactor Switching Cycles K3

Profibus Byte offset	Bit offset	Data type	Description
90	0	Unsigned32	MStart Insertion cycles
94	0	Unsigned32	Operating hours [h]
98	0	Unsigned16	TOL - Thermal Image [%]
100	0	Unsigned16	TOL - Time To Reset [s]
102	0	Unsigned16	TOL - Time To Trip [s]
104	0	Unsigned16	Measured PTC resistance [Ω]
106	0	Integer16	PT100-3Ch Temperature Sensor1 [0.1 °C] ⁴⁾ (only if respective HW available)
108	0	Integer16	PT100-3Ch Temperature Sensor2 [0.1 °C] ⁴⁾ (only if respective HW available)
110	0	Integer16	PT100-3Ch Temperature Sensor3 [0.1 °C] ⁴⁾ (only if respective HW available)
112	0	Unsigned16	GPI: Up to 16 user assigned input signals
114	0	Unsigned16	GPAI: User configurable Analog value (mostly [0.1 %] ⁵⁾)
116	0	Floating point	Measured Motor Start Time [s]
120	0	Floating point	Current at Trip phase L1 [A]
124	0	Floating point	Current at Trip phase L2 [A]
128	0	Floating point	Current at Trip phase L3 [A]
132	0	Unsigned8	Quality code bit field to indicate whether current at trip is valid: Bit 7: no Current at Trip stored Bit 2: Current at Trip L3 not valid Bit 1: Current at Trip L2 not valid Bit 0: Current at Trip L1 not valid
133	0	Unsigned8	Always zero
134	0	Integer16	MControl Base Version ⁹⁾
136	0	Unsigned8[6]	UUID read from MStart
142	0	TimeStamp ⁶⁾	The timestamp of the last Earo Entry change
150	0	EaroEntryT ¹⁾	TOL/TOL Eexe
150	4	EaroEntryT ¹⁾	Control Module IO card failure
151	0	EaroEntryT ¹⁾	PTC Supervision
151	4	EaroEntryT ¹⁾	DC 4Di2Do card failure
152	0	EaroEntryT ¹⁾	PTC Short Circuit
152	4	EaroEntryT ¹⁾	AC 4Di2Do card failure
153	0	EaroEntryT ¹⁾	PTC Open Circuit
153	4	EaroEntryT ¹⁾	AC 7Di0Do card failure

Profibus Byte offset	Bit offset	Data type	Description
154	0	EaroEntryT ⁽¹⁾	Underload
154	4	EaroEntryT ⁽¹⁾	AiAo card failure
155	0	EaroEntryT ⁽¹⁾	Underload CosPhi
155	4	EaroEntryT ⁽¹⁾	2Ai0Ao card failure
156	0	EaroEntryT ⁽¹⁾	Phase Failure
156	4	EaroEntryT ⁽¹⁾	PTC card failure
157	0	EaroEntryT ⁽¹⁾	- Reserved -
158	0	EaroEntryT ⁽¹⁾	- Reserved -
159	0	EaroEntryT ⁽¹⁾	Phase Unbalance
160	0	EaroEntryT ⁽¹⁾	Undervoltage
161	0	EaroEntryT ⁽¹⁾	Control Voltage
162	0	EaroEntryT ⁽¹⁾	Start Limitation
163	0	EaroEntryT ⁽¹⁾	Autorestart Inhibit
164	0	EaroEntryT ⁽¹⁾	Unprotected Mode 1
164	4	EaroEntryT ⁽¹⁾	Unprotected Mode 2
165	0	EaroEntryT ⁽¹⁾	EM-Stop
166	0	EaroEntryT ⁽¹⁾	Mainswitch Supervision
167	0	EaroEntryT ⁽¹⁾	Feedback Supervision (K1)
168	0	EaroEntryT ⁽¹⁾	Feedback Supervision (K2)
168	4	EaroEntryT ⁽¹⁾	Feeder MCB trip
169	0	EaroEntryT ⁽¹⁾	Feedback Supervision (K3)
170	0	EaroEntryT ⁽¹⁾	Motor Still Running
170	4	EaroEntryT ⁽¹⁾	Unexpected Feeder Current
171	0	EaroEntryT ⁽¹⁾	Motor Not Running
171	4	EaroEntryT ⁽¹⁾	Soft starter
172	0	EaroEntryT ⁽¹⁾	Welded
173	0	EaroEntryT ⁽¹⁾	Testmode Failure
174	0	EaroEntryT ⁽¹⁾	No Load
175	0	EaroEntryT ⁽¹⁾	Stall
176	0	EaroEntryT ⁽¹⁾	Earth Leakage
177	0	EaroEntryT ⁽¹⁾	Contact Temperature Unbalance
178	0	EaroEntryT ⁽¹⁾	External Trip 1
179	0	EaroEntryT ⁽¹⁾	External Trip 2
180	0	EaroEntryT ⁽¹⁾	IRF (Hardware)
181	0	EaroEntryT ⁽¹⁾	Actuator: Both End Switches Active
182	0	EaroEntryT ⁽¹⁾	Actuator: Torque Open

Profibus Byte offset	Bit offset	Data type	Description
183	0	EaroEntryT ¹⁾	Actuator: Torque Close
184	0	EaroEntryT ¹⁾	Act. Power Superv. Low Limit
184	4	EaroEntryT ¹⁾	Act. Power Superv. High Limit
185	0	EaroEntryT ¹⁾	PT100-1Ch Card Failure <i>(following data only if respective HW available)</i>
186	0	EaroEntryT ¹⁾	PT100-1Ch Sensor Low Limit
186	4	EaroEntryT ¹⁾	PT100-1Ch Sensor Short Circuit
187	0	EaroEntryT ¹⁾	PT100-1Ch Sensor High Limit
187	4	EaroEntryT ¹⁾	PT100-1Ch Sensor Open Circuit
188	0	EaroEntryT ¹⁾	PT100-3Ch Card Failure <i>(following data only if respective HW available))</i>
189	0	EaroEntryT ¹⁾	PT100-3Ch Sensor1 Low Limit
189	4	EaroEntryT ²⁾	PT100-3Ch Sensor1 Short Circuit
190	0	EaroEntryT ¹⁾	PT100-3Ch Sensor1 High Limit
190	4	EaroEntryT ²⁾	PT100-3Ch Sensor1 Open Circuit
191	0	EaroEntryT ¹⁾	PT100-3Ch Sensor2 Low Limit
191	4	EaroEntryT ²⁾	PT100-3Ch Sensor2 Short Circuit
192	0	EaroEntryT ¹⁾	PT100-3Ch Sensor2 High Limit
192	4	EaroEntryT ²⁾	PT100-3Ch Sensor2 Open Circuit
193	0	EaroEntryT ¹⁾	PT100-3Ch Sensor3 Low Limit
193	4	EaroEntryT ²⁾	PT100-3Ch Sensor3 Short Circuit
194	0	EaroEntryT ¹⁾	PT100-3Ch Sensor3 High Limit
194	4	EaroEntryT ²⁾	PT100-3Ch Sensor3 Open Circuit
195	0	EaroEntryT ¹⁾	Fuse Supervision L1
195	4	EaroEntryT ¹⁾	Fuse Supervision Configuration Mismatch
196	0	EaroEntryT ¹⁾	Fuse Supervision L2
197	0	EaroEntryT ¹⁾	Fuse Supervision L3
198	0	EaroEntryT ¹⁾	Contact Temperature Supervision (L1)
199	0	EaroEntryT ¹⁾	Contact Temperature Supervision (L2)
200	0	EaroEntryT ¹⁾	Contact Temperature Supervision (L3)
201	0	EaroEntryT ¹⁾	- Reserved -
202	0	EaroEntryT ¹⁾	- Reserved -
203	0	EaroEntryT ¹⁾	- Reserved -
204	0	EaroEntryT ¹⁾	Switch Cycle Supervision (K1)
205	0	EaroEntryT ¹⁾	Switch Cycle Supervision (K2)
206	0	EaroEntryT ¹⁾	Switch Cycle Supervision (K3)
207	0	EaroEntryT ¹⁾	Operating Hours
208	0	EaroEntryT ¹⁾	Power Module Insertion Cycles

Profibus Byte offset	Bit offset	Data type	Description
209	0	EaroEntryT ¹⁾	Star/Delta-Transition Failed
210	0	EaroEntryT ¹⁾	MStart ID Error
210	4	EaroEntryT ¹⁾	MStart Range Error
211	0	EaroEntryT ¹⁾	MStart Communication Error
211	4	EaroEntryT ¹⁾	Minimum Protection Mode
212	0	EaroEntryT ¹⁾	Location Supervision
213	0	EaroEntryT ¹⁾	IRF (Software)
214	0	Unsigned16	- Event [3] -
220	0	Integer16	PT100-1Ch Temperature [0.1 °C] ⁴⁾ (only if respective HW available)
222		Unsigned32	Active Energy Counter [0.1 kWh] ³⁾
226	0	Integer16	Analog input value from AI1 of 2Ai0Ao-I/O-module or AI of 1Ai0Ao-I/O-module [0.1 %] ⁵⁾ (only if respective HW available)
228	0	Integer16	Analog input value from AI2 of 2Ai0Ao-I/O-module [0.1 %] ⁵⁾ (only if respective HW available)
230	0	Unsigned16	OS Version
232 - 244	0	Unsigned8	Reserved space all filled with 0

¹⁾ Bit field maps to the lower 4 bit (3,2,1,0) of the byte: (trip resettable, trip acknowledged, trip new, alarm)

²⁾ Bit field maps to the higher 4 bit (7,6,5,4) of the byte: (trip resettable, trip acknowledged, trip new, alarm)

³⁾ Transferred value is multiplied by 10 to allow for 1 fractional digit. The value 1234 means 123.4 kWh

⁴⁾ Transferred value is multiplied by 10 to allow for 1 fractional digit. The value 1234 means 123.4 °C

⁵⁾ Transferred value is multiplied by 10 to allow for 1 fractional digit. The value 1234 means 123.4

⁶⁾ TimestampT is a timestamp with this format:

Byte	Data Type	Contents
1	Unsigned8	Year: 0 ^(*) , 1 ... 199
2	Unsigned8	Month: 0 ^(*) , 1 ... 12
3	Unsigned8	Day: 0 ^(*) , 1 ... 31
4	Unsigned8	Hour: 0 ... 23
5	Unsigned8	Minute: 0 ... 59
6	Unsigned8	Second: 0 ... 59
7,8	Unsigned8	Millisecond: 0 ... 999

^(*) If the timestamp is invalid the entries for Year, Month and Day are set to zero!

Quality Code

The Quality Codes are bit fields indicating whether the measurement values are valid or not.

- If the bit is cleared (“0”) the data value is valid.
- If the bit is set (“1”) the data value is invalid

Profibus Byte	QualityCode1 Bit (Unsigned32)	Data
Byte 0	31	Reserved
	30	MStart Insertion Cycles
	29	Contacting Switching Cycles K1,K2,K3
	28	Control Voltage Reset Level
	27	Reserved
	26	Test Switch On
	25	Main Switch On
	24	Contacting Feedback
Byte 1	23	Reserved
	22	Frequency
	21	Reactive Power
	20	Active Power
	19	Apparent Power
	18	Cos Phi
	17	Reserved
	16	Reserved
Byte 2	15	Reserved
	14	Contact Temperature L3
	13	Contact Temperature L2
	12	Contact Temperature L1
	11	Reserved
	10	Reserved
	9	Reserved
	8	Phase Voltage U31
Byte 3	7	Phase Voltage U23
	6	Phase Voltage U12, Phase Voltage U1 (single phase system)
	5	Earth fault current I0
	4	IL3 (Percent)
	3	IL2 (Percent)
	2	IL1 (Percent)
	1	U nominal, F nominal
	0	Reserved

Profibus Byte	QualityCode2 Bit (Unsigned32)	Data
Byte 4	31	Thermal Image
	30	TOL - Time To Reset
	29	TOL - Time To Trip
	28	AI2 (for 2AI Interface card)
	27	AI (for AiAo Interface card) / AI1 (or 2AI Interface card)
	26	PTC resistance (only if respective HW available)
	25	Reserved
	24	Measured Motor Start Time
Byte 5	23	Reserved
	22	PT100_3CH_Temperature3 (only if respective HW available)
	21	PT100_3CH_Temperature2 (only if respective HW available)
	20	PT100_3CH_Temperature1 (only if respective HW available)
	19	PT100_1CH_Temperature (only if respective HW available)
	18	Reserved
	17	Reserved
	16	Reserved
Byte 6	15	GPI16
	14	GPI15
	13	GPI14
	12	GPI13
	11	GPI12
	10	GPI11
	9	GPI10
	8	GPI9
Byte 7	7	GPI8
	6	GPI7
	5	GPI6
	4	GPI5
	3	GPI4
	2	GPI3
	1	GPI2
	0	GPI1

MControl status

MControl status format is of data type Unsigned 32 (4Byte, Motorola Byte order):

Byte order	Section	Bit (Unsigned32)	Description
Byte 8	Control Access Owner	31	Remote
		30	Reserved
		29	Reserved
		28	Reserved
		27	MControl Fieldbus Interface
		26	Bus Local (MView-HMI)
		25	Soft Local
		24	Hardware Local
Byte 9	Various input signals	23	Set if TOL bypass is activated
		22	Set if TOL startup inhibit is active
		21	Set if MControl is locked out: The MControl can not be started due to TOL startup inhibit or an external inhibit signal (via DI)
		20	Set if MStart is in isolated position
		19	. MControl is in Minimum Protection mode, some measurements are missing and motor is running with no proper protection.
		18	MControl is in proof test mode, the protection functions except TOL associated with current is not activated
		17	Set if Main Switch is ON
		16	Set if Test Position is ON
Byte 10		15-13	Starter dependent information (see table below)
	Failsafe	12	Starter entered failsafe status
	EaroEntryT	11	Trip Resettable
		10	Trip Acknowledged
		9	Trip New
8		Alarm	
Byte 11	Starter State	7-0	Starter dependent information (see table below)

Starter dependent information

Bit	NR-DOL	NR-DOL RCU	REV-DOL	REV-DOL RCU	NoStarter	NR-DOI Star/Delta	NR-DOL Softstarter	Actuator	Transparent (with/without Control)	Feeder	Feeder DC/1phase-AC	C-Feeder	C-Feeder RCU
15	0	0	0	0	1	0	0	1	0	1	1	1	1
14	0	1	0	1	1	0	1	0	0	1	1	1	1
13	0	1	0	1	1	1	0	0	0	0	0	0	0
7	Ready	Ready	Ready	Ready	Ready	Ready	Ready	Ready	Ready	0	0	Ready	Ready
6	0	0	0	0	0	(Runs) Star	Softstart	Open Position	0	0	0	0	0
5	0	0	0	0	0	0	Softstop	Close Position	0	0	0	0	0
4	0	0	0	0	0	0	0	0	K3	0	0	0	0
3	0	0	(Runs) CCW	(Runs) CCW	(Runs) CCW	0	0	(Runs) open	K2	0	0	0	0
2	0	0	(Runs) CW	(Runs) CW	(Runs) CW	0	0	(Runs) close	K1	0	0	0	0
1	Runs	Runs	Runs	Runs	Runs	Runs	Runs	Runs	0	Closed	Closed	Closed	Closed
0	Stopped	Stopped	Stopped	Stopped	Stopped	Stopped	Stopped	Stopped	0	Opened	Opened	Opened	Opened

Command format

The command data are available in 3 formats:

- Format 0
- Format 1
- Format 2

Each format extends the range of control.

The control via Profibus depends very much on the “Auto-Mode”-Bit of the control structure. Whenever this Bit is set and “HW-Local” is not active the control is possible via Profibus.



To avoid future incompatibilities all unused and reserved bits in the command structure must be set to 0.

Format 0:

Byte	Bit7	Bit6	Bit5	Bit4	Bit3	Bit2	Bit1	Bit0
0	Reserved	Trip Reset	Auto-Mode	Unused	Unused	Starter Control		
1	Failsafe activate	Reserved	Reserved	Reserved	Reserved	Reserved	Reserved	Reserved

Format 1:

Byte	Bit7	Bit6	Bit5	Bit4	Bit3	Bit2	Bit1	Bit0
0	Reserved	Trip Reset	Auto-Mode	Unused	Unused	Starter Control		
1	Failsafe activate	Reserved	Reserved	Reserved	Reserved	Reserved	Reserved	Reserved
2	GO8	GO7	GO6	GO5	GO4	GO3	GO2	GO1
3	Reserved	Reserved	Reserved	Reserved	Reserved	Reserved	Reserved	Reserved

Format 2:

Byte	Bit7	Bit6	Bit5	Bit4	Bit3	Bit2	Bit1	Bit0
0	Reserved	Trip Reset	Auto-Mode	Unused	Unused	Starter Control (see table below)		
1	Failsafe activate	Reserved	Reserved	Reserved	Reserved	Reserved	Reserved	Reserved
2	GO8	GO7	GO6	GO5	GO4	GO3	GO2	GO1
3	Reserved	Reserved	Reserved	Reserved	Reserved	Reserved	Reserved	Reserved
4	GPO8	GPO7	GPO6	GPO5	GPO4	GPO3	GPO2	GPO1
5	AO1– high[o/oo] ^{*)}							
6	AO1– low[o/oo] ^{*)}							
7	APO1– high[o/oo] ^{*)}							
8	APO1– low[o/oo] ^{*)}							
9	Reserved	Reserved	Reserved	Reserved	Reserved	Reserved	Reserved	Reserved
10	Reserved	Reserved	Reserved	Reserved	Reserved	Reserved	Reserved	Reserved
11	Reserved	Reserved	Reserved	Reserved	Reserved	Reserved	Reserved	Reserved
12	Reserved	Reserved	Reserved	Reserved	Reserved	Reserved	Reserved	Reserved

^{*)} Example: For a AO1/APO1 setpoint of 66,5 % the value 665 has to be written!

The starter dependent control bits are encoded as follows:

Starter type	Bit 2	Bit 1	Bit 0
NR-DOL NR-DOL-RCU	Start	Stop	Reserved (=0)
REV-DOL REV-DOL-RCU	Start CW	Stop	Start CCW
NR-DOL StarDelta	Start	Stop	Reserved (=0)
NoStarter	Start CW	Stop	Start CCW
NR-DOL Softstarter	Start	Stop	Reseverd (=0)
Transparent	K3	K2	K1
Transparent with Control	Reserved (=0)	Reserved (=0)	K1 (Open/Close)
Transparent without Control	Reserved (=0)	Reserved (=0)	Reserved (=0)
Actuator	Start open	Stopped	Start close
Feeder	Reserved (=0)	Reserved (=0)	Reserved (=0)
Feeder DC/1phase-AC	Reserved (=0)	Reserved (=0)	Reserved (=0)
C-Feeder	Close	Open	Reserved (=0)
C-Feeder RCU	Close	Open	Reserved (=0)



If “Stop” is set the starter is stopped and the other bits are invalid.

“Start CW” and “Start CCW” as well as “K1” and “K2” may not be set simultaneously.

If Actuator is open “Start open” command is ignored. If Actuator is closed “Start close” command is ignored.

Profibus Byte / Bit	Function		
Byte0 / Bit6	Trip Reset	1 = if there are resettable trips the trips are reset	
Byte0 / Bit5	Auto Mode	1 = the control is passed to MControl Profibus Direct interface Note: only if CA=“Hardware Local” is not active!	
Byte0 / Bit2 Byte0 / Bit1 Byte0 / Bit0	Starter Control	Starter dependent <i>Control</i> bits (see table above)	
Byte1 / Bit7	Failsafe	1 = Profibus master is failsafe master	

Profibus Byte / Bit	Function	
Byte2 / Bit7	GO 8	General Purpose Out 8 will follow this bit
Byte2 / Bit6	GO 7	General Purpose Out 7 will follow this bit
Byte2 / Bit5	GO 6	General Purpose Out 6 will follow this bit
Byte2 / Bit4	GO 5	General Purpose Out 5 will follow this bit
Byte2 / Bit3	GO 4	General Purpose Out 4 will follow this bit
Byte2 / Bit2	GO 3	General Purpose Out 3 will follow this bit
Byte2 / Bit1	GO 2	General Purpose Out 2 will follow this bit
Byte2 / Bit0	GO 1	General Purpose Out 1 will follow this bit
Byte3 / Bit 7	GPO 8	General Purpose Out 8 (persistent) will follow this bit
Byte3 / Bit6	GPO 7	General Purpose Out 7 (persistent) will follow this bit
Byte3 / Bit5	GPO 6	General Purpose Out 6 (persistent) will follow this bit
Byte3 / Bit4	GPO 5	General Purpose Out 5 (persistent) will follow this bit
Byte3 / Bit3	GPO 4	General Purpose Out 4 (persistent) will follow this bit
Byte3 / Bit2	GPO 3	General Purpose Out 3 (persistent) will follow this bit
Byte3 / Bit1	GPO 2	General Purpose Out 2 (persistent) will follow this bit
Byte3 / Bit0	GPO 1	General Purpose Out 1 (persistent) will follow this bit
Byte4	GAO high	High byte of General Purpose Analogue Out will follow this byte
Byte5	GAO low	Low byte of General Purpose Analogue Out will follow this byte
Byte7	GPAO high	High byte of General Purpose Analogue Out (persistent) will follow this byte
Byte8	GPAO low	Low byte of General Purpose Analogue Out (persistent) will follow this byte

Note: Auto Mode must be set ("1")

Contact us

ABB Low Voltage Systems

Publication Editor:
ABB Automation Products GmbH
Ladenburg, Germany

Local Contacts on
www.abb.com/mns

Copyright© 2015 ABB
All rights reserved.

Publication No.
1TGC910283M0202