

INSTRUCTION MANUAL

with Parts List
FLOW PRODUCTS

10A4500/10A4600 DESIGN LEVEL B



V/A MASTER™ FLOWMETERS

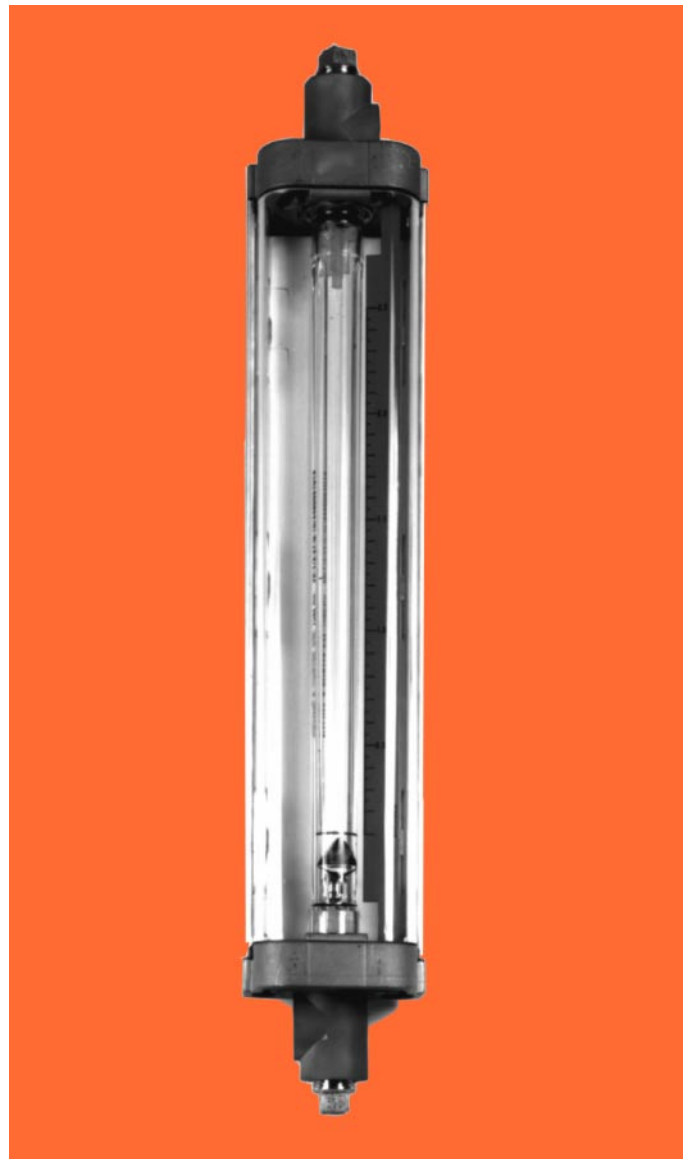

PN 24987

ABB Instrumentation



The following is a trademark of ABB Automation Inc:

V/A MASTER

The following are registered trademarks of E. I. du Pont de Nemours and Company:

TEFLON®
VITON®

The following is a trademark of Richard Klinger, Incorporated:

KLINGER SIL C-4401

WARNING notices as used in this manual apply to hazards or unsafe practices which could result in personal injury or death.

CAUTION notices apply to hazards or unsafe practices which could result in property damage.

NOTES highlight procedures and contain information which assist the operator in understanding the information contained in this manual.

All software, including design, appearance, algorithms and source codes, is owned and copyrighted by ABB Automation Inc. or its suppliers.

WARNING

POSSIBLE PROCESS UPSETS

Maintenance must be performed only by qualified personnel and only after securing equipment controlled by this product. Adjusting or removing this product while it is in the system may upset the process being controlled. Some process upsets may cause injury or damage.

NOTICE

The information contained in this document is subject to change without notice. ABB Automation Inc. reserves the right to make minor changes to this publication, such as company name & logos as well as other minor corrections, without necessarily changing the publication number.

ABB Automation Inc., its affiliates, employees, and agents, and the authors of and contributors to this publication specifically disclaim all liabilities and warranties, express and implied (including warranties of merchantability and fitness for a particular purpose), for the accuracy, currency, completeness, and/or reliability of the information contained herein and/or for the fitness for any particular use and/or for the performance of any material and/or equipment selected in whole or part with the user of/or in reliance upon information contained herein. Selection of materials and/or equipment is at the sole risk of the user of this publication.

This document contains proprietary information of ABB Automation Inc. and is issued in strict confidence. Its use, or reproduction for use, for the reverse engineering, development or manufacture of hardware or software described herein is prohibited. No part of this document may be photocopied or reproduced without the prior written consent of ABB Automation Inc.

10A4500/4600B V/A MASTER Flowmeters

ADDENDUM

THE PURPOSE OF THIS ADDENDUM IS TO SUPPLEMENT OR
SUPERSEDE INFORMATION CONTAINED IN 10A4500/4600B
V/A FLOWMETER INSTRUCTION MANUAL, PN24987

The information contained on Page 3-4 of 10A4500/4600B V/A Flowmeter Instruction Manual (PN24987) has been revised. The new information is as shown below (changes are indicated in *italics*).

TABLE 3-1 CABLE LENGTHS

TRANSMITTER LOCATION	MAXIMUM LENGTH (Note 1)*
Non-Hazardous or Div. 2	<i>1 mi. (1.5 km)</i>
Class I, Div. I, Groups A and B	<i>3000 ft. (900 m)</i>
Class I, Div. I, Groups C and D	<i>1 mi. (1.5 km)</i>
Class II, Div. I, Groups E, F and G	<i>1 mi. (1.5 km)</i>

*Cable Capacitance: less than 60 picofarad/ft (197 picofarad/m)
Inductance: less than 0.2 microhenry/ft (0.656 microhenry/m)

Note:

1. Field wiring between sensor switches and control amplifiers should be twisted pair wire, #25 AWG or larger. Maximum cable length shall be per Table 3-1. The sensor switches are provided with five feet (1.5 m) of cable. All additional field wiring is supplied by user.



Table of Contents

READ FIRST I

1.0 INTRODUCTION 1-1

1.1 Model Number Breakdown 1-2

2.0 INSTALLATION 2-1

2.1 Float Installation 2-1

2.2 Orienting Horizontal End Fittings 2-1

 2.2.1 Model 10A4500. 2-1

 2.2.2 Model 10A4600. 2-1

2.3 Surge Chambers and Accumulators 2-2

2.4 Mounting and Piping 2-4

 2.4.1 General 2-4

 2.4.2 Liquid Service 2-4

 2.4.3 Gas Service 2-4

 2.4.4 Pipe Mounting. 2-4

 2.4.5 Panel Mounting. 2-5

 2.4.5.1 General. 2-5

 2.4.5.2 Rear Panel Installation 2-5

 2.4.5.3 Front Panel Installation. 2-6

3.0 PLACING IN OPERATION 3-1

3.1 General 3-1

3.2 Liquid Service 3-2

3.3 Gas Service 3-2

3.4 Alarms. 3-2

 3.4.1 Alarm Specifications 3-4

4.0 MAINTENANCE 4-1

4.1 General 4-1

4.2 Cleaning Operator Protection Shield 4-1

4.3 10A4500 Flowmeter Tube and Float Removal and Installation 4-2

 4.3.1 10A4500 Flowmeter Tube and Float Removal 4-2

 4.3.2 10A4500 Flowmeter Tube and Float Installation 4-2

4.4 10A4600 Flowmeter Tube and Float Removal and Installation 4-3

 4.4.1 10A4600 Flowmeter Tube and Float Removal 4-3

 4.4.2 10A4600 Flowmeter Tube and Float Installation 4-3

4.5 Disassembly 4-4

4.6 Metal Scales 4-4

5.0 PARTS LIST 5-1

Figure List

FIGURE 2-1. ROTATING THE END FITTING ON HORIZONTAL CONNECTIONS	2-2
FIGURE 2-2. TYPICAL VERTICAL PIPING INSTALLATION USING HORIZONTAL CONNECTIONS	2-3
FIGURE 2-3. TYPICAL HORIZONTAL PIPING INSTALLATION	2-3
FIGURE 2-4. OUTLINE DIMENSIONS OF BASIC METER	2-7
FIGURE 2-5. OUTLINE DIMENSIONS FOR FRONT PANEL MOUNTING	2-8
FIGURE 2-6. OUTLINE DIMENSIONS FOR REAR PANEL MOUNTING	2-9
FIGURE 2-7. OUTLINE DIMENSIONS FOR ALARM OPTION	2-10
FIGURE 2-8. OUTLINE DIMENSIONS FOR FRONT PANEL MOUNTING WITH ALARM OPTION	2-11
FIGURE 3-1. FLOAT READING EDGES	3-1
FIGURE 3-2. ALARM SENSOR POSITIONING	3-3
FIGURE 3-3. SINGLE (LOW) ALARM SINGLE POLE DOUBLE THROW RELAY OUTPUT	3-5
FIGURE 3-4. DUAL (HIGH/LOW) ALARM SINGLE POLE DOUBLE THROW RELAY OUTPUT	3-6
FIGURE 3-5. SINGLE (LOW) ALARM DOUBLE POLE DOUBLE THROW RELAY OUTPUT	3-7
FIGURE 3-6. DUAL (HIGH/LOW) ALARM DOUBLE POLE DOUBLE THROW RELAY OUTPUT	3-8
FIGURE 3-7. SINGLE (HIGH) ALARM SINGLE POLE DOUBLE THROW RELAY OUTPUT	3-9
FIGURE 3-8. SINGLE (HIGH) ALARM DOUBLE POLE DOUBLE THROW RELAY OUTPUT	3-10
FIGURE 3-9. DUAL (HIGH/HIGH) ALARM SINGLE POLE DOUBLE THROW RELAY OUTPUT	3-11
FIGURE 3-10. DUAL (LOW/LOW) ALARM SINGLE POLE DOUBLE THROW RELAY OUTPUT	3-12
FIGURE 3-11. DUAL (HIGH/HIGH) ALARM DOUBLE POLE DOUBLE THROW RELAY OUTPUT	3-13
FIGURE 3-12. DUAL (LOW/LOW) ALARM DOUBLE POLE DOUBLE THROW RELAY OUTPUT	3-14
FIGURE 3-13. OUTLINE DIMENSIONS OF CONTROL AMPLIFIER	3-15
FIGURE 5-1. 10A4500 METER ASSEMBLY	5-3
FIGURE 5-2. 10A4600 METER ASSEMBLY	5-7
FIGURE 5-3. PVC END FITTINGS	5-8
FIGURE 5-4. ALARM ASSEMBLY	5-9
FIGURE 5-5. REAR PANEL MOUNTING	5-10

Table List

TABLE I-I. METER PRESSURE RATING at 250° F (120° C)	II
TABLE I-II. PRESSURE - TEMPERATURE RATINGS FOR PVC END FITTINGS	III
TABLE 1-1. METERS WITH THREADED CONNECTIONS	1-1
TABLE 1-2. METERS WITH FLANGE CONNECTIONS	1-1
TABLE 3-1 CABLE LENGTHS	3-4
TABLE 5-1. 10A4500 METER PARTS	5-1
TABLE 5-2. 10A4600 METER PARTS	5-4

READ FIRST

WARNING

INSTRUCTION MANUALS

Do not install, maintain, or operate this equipment without reading, understanding and following the proper ABB Automation instructions and manuals, otherwise injury or damage may result.

RETURN OF EQUIPMENT

All Flowmeters being returned to ABB Automation for repair must be free of any hazardous materials (acids, alkalis, solvents, etc). A Material Safety Data Sheet (MSDS) for all process liquids must accompany returned equipment. Contact ABB Automation for authorization prior to returning equipment.

**Read these instructions before starting installation;
save these instructions for future reference.**

Contacting ABB Automation Inc.

Should assistance be required with any ABB Instrumentation product, contact the following:

Telephone:

**ABB Instrumentation Technical Support Center
1 (800) 697-9619**

E-Mail:

ins.techsupport@us.abb.com

**THE FOLLOWING PRECAUTIONARY MEASURES MUST BE OBSERVED
TO MINIMIZE THE POSSIBILITY OF OPERATOR INJURY.**

General

1) Glass meter tubes have been designed to operate up to maximum design working pressures and temperatures specified in Table I-I. This is not a certification that the glass tubes will not break at less than specified pressure. Inherent material limitations can result in tube breakage due to conditions beyond our control. For example; glass is a brittle material which may break upon impact; glass if subjected to thermal shock may break; glass is notch sensitive in that scratches, nicks or cracks may result in breakage when pressurized; faulty installation or operating methods can cause tube breakage regardless of operating pressure.

2) Glass meter tubes are not recommended for either hot or strong alkalis, fluorine, hydrofluoric acid, steam or water over 200° F (93° C). Glass meter tubes should be periodically inspected for signs of wear. With certain fluids, the glass may erode evenly so wear is not visible. If wear is suspected, the tube must be replaced.

3) It is important that all materials of construction be compatible with the service to which the meter is applied. It is especially important that O-ring material be compatible with the process fluid. Glass meter tube breakage can occur if the improper material is used.

**WARNING
VITON® O-RINGS MUST NEVER BE USED FOR AMMONIA SERVICE;
THE CORROSIVE ATTACK OF AMMONIA ON VITON IS EXTREME,
CAUSING THE O-RING TO SWELL AND BREAK THE GLASS METER
TUBE.**

4) The flowmeter should never be subjected to excessive vibration.

5) The use of a pressure relief valve and/or a rupture disc is recommended in the pipeline containing the flowmeter. The device should be located such to preclude glass meter tube breakage in the event of an over pressurization of the line.

Avoid the use of quick acting devices in the fluid stream in order to prevent hydraulic shock waves from damaging the meter.

6) When applied to a high pressure gas cylinder, at least two stepdown pressure regulators are to be used between the flowmeter and the cylinder.

7) Remove pressure from the flowmeter before attempting to remove the meter tube.

8) Be sure the fasteners that lock the meter end fittings in place are secure. This must be checked before the flowmeter is put into service or returned to service after maintenance. Loose end fittings may result in glass meter tube breakage.

9) The glass meter tube must be periodically inspected and replaced if cracked, nicked, scratched or worn.

10) The operator protection shield must be inspected periodically to see that it is safe. Inspect for any degradation of the shield such as crazing or stress cracks; this is cause for immediate replacement.

11) If the flowmeter has packing glands to seal the tube to the end fittings, they should be tightened evenly to avoid strains on the glass tube. Tighten the packing glands only as tight as necessary to prevent leaks.

12) It is recommended that the piping system be checked for leaks prior to start-up.

WARNING
DO NOT OPERATE FLOWMETER WITHOUT OPERATOR PROTECTION SHIELD IN PLACE. TO DO SO MAY RESULT IN OPERATOR INJURY.

TABLE I-I. METER PRESSURE RATING at 250° F (120° C)*

* Maximum Design Pressure in psig (kPa)
 Minimum Operating Temperature 32° F (0° C)

METER SIZE	ALL NPT CONNECTIONS	MATERIAL OF CLASS 125/150 ANSI FLANGE CONNECTIONS	
		316 SST	BRASS
1/2*	300 (2070)	275 (1895)**	225 (1550)**
3/4 - 1	200 (1380)	200 (1380)	200 (1380)
1 1/2	130 (895)	130 (895)	130 (895)
2	100 (690)	100 (690)	100 (690)

* The pressure rating of the 1/2 inch flanged meter will decrease as temperatures increase. Derating occurs at temperatures of 100° F (38° C) to 250° F (120° C). Consult ABB Automation for specific pressure vs temperature factors.

** Values shown are at 100° F.

Limitations When Using PVC Process Connections

NOTE
 Flowmeters with PVC process connections are **not recommended for gas service.**

Nonmetallic process connections reduce the amount of metal exposed to the process fluid. PVC process connections are available with **VERTICAL CONNECTIONS ONLY.**

Flowmeters with PVC process connections have lower pressure ratings than meters with metal connections. The following Table I-II provides the pressure rating of the PVC process connections at various temperatures.

The minimum operating temperature on water service is 32° F (0° C); **the maximum operating temperature on any service is 140° F (60° C).**

INSTRUCTION MANUAL 10A4500/4600 V/A MASTER FLOWMETER

All flowmeters with PVC process connections are of the 10A4600 design which uses neoprene packing with a TEFLON® liner on the wetted side.

The flowmeter with PVC process connections must be supported to eliminate any strain on the connections. It is suggested that the process piping be supported to relieve the strain on the meter connections. Alternately, the flowmeter can be panel mounted to carry the weight of the flowmeter. When flanged connections are supplied, use a flat full face gasket.

WARNING
PVC THREADED CONNECTIONS: Use only TEFLON tape when joining PVC threaded connections. The use of pipe dope can cause embrittlement in the thread area, resulting in a possible fracture and/or failure at the connection.

TABLE I-II. PRESSURE - TEMPERATURE RATINGS FOR PVC END FITTINGS

CONNECTION TYPE	CONNECTION SIZE	TUBE SIZE	TEMPERATURE, ° F										
			32-90	95	100	105	110	115	120	125	130	135	140
			PRESSURE RATING, psig										
NPT	1/2	1/2	300	282	260	235	210	189	168	147	126	109	92
	3/4	3/4, 1	200			190	170	153	136	119	102	88	75
	1 1/2	1 1/2	130				120	108	96	84	72	62	53
		2	100						96	84	72	62	53
ANSI 150 Flange	1/2, 1	1/2, 3/4, 1	150			144	135	123	110	93	75	61	50
	1 1/2	1 1/2	130				123	110	93	75	61	50	
		2	100						93	75	61	50	

1.0 INTRODUCTION

The ABB Automation Series V/A MASTER™ flowmeters operate on the variable area principle to measure and visibly indicate the instantaneous fluid flow rate of liquids and gases. These weather-resistant meters have stainless steel bodies that retain the inlet and outlet end fittings. The end fittings hold the meter tube, and are designed to permit removal of the tube for cleaning or range changes without disassembling the meter or removing the process piping. Either O-rings or packing gland seals are used as pressure seals between the tube and end fittings. The meter must always be mounted vertically. It is available with either vertical or horizontal connections which can be threaded or flanged.

V/A MASTER flowmeters are available in 1/2 through 2 inch diameter **metering tubes** that have a nominal 10 inch reading scale. Connections are either **threaded or flanged** and are available in sizes 1/2 through 1 1/2 inches. The meter size is designated as 1/2" X 1/2", 3/4" X 1", etc. The first dimension denotes the meter connection size, in inches, and the second dimension is the nominal diameter of the inlet to the metering section of the tube. Refer to Tables 1-1 and 1-2.

TABLE 1-1. METERS WITH THREADED CONNECTIONS

THREADED CONNECTION	TUBE SIZE	METER SIZE DESIGNATION
1/2	1/2	1/2 x 1/2
3/4	3/4	3/4 x 3/4
3/4	1	3/4 x 1
1 1/2	1 1/2	1 1/2 x 1 1/2
1 1/2	2	1 1/2 x 2

TABLE 1-2. METERS WITH FLANGE CONNECTIONS

FLANGE CONNECTION	TUBE SIZE	METER SIZE DESIGNATION
1/2	1/2	1/2 x 1/2
1	3/4	1 x 3/4
1	1	1 x 1
1 1/2	1 1/2	1 1/2 x 1 1/2
1 1/2	2	1 1/2 x 2

Several different shapes of metering floats are used with the meter to provide the proper weight, density and material required for the application. The elevation of the float in the tapered meter tube is proportional to the instantaneous fluid flow rate. Readings are taken from the metal scale plate adjacent to the meter tube which provides a "percent of maximum flow" reading. In addition, a "direct reading" scale can also be supplied either on the metal scale or, as a special option, etched on the tube.

New meters are provided with O-rings or packing of the material specified at the time of purchase. Should the process fluid being metered require a material change, the O-rings or packing can be changed in the field.

It is important that all materials of construction be compatible with the service to which the meter is applied. It is especially important that O-ring material be compatible with the process fluid. Glass meter tube breakage can occur if the improper material is used.

1.1 Model Number Breakdown

Refer to the ABB Automation tag on the meter for the model number of the meter. The details of a specific number are as follows:

	10A4					B									
Engineering Reference	10A4														
Seals															
O-ring Pressure Seals															55
Packing Gland Pressure Seals															65
Connection Designation															
Horizontal Threaded															5
Horizontal Flanged															6
Vertical Threaded															7
Vertical Flanged															8
Scales															
Percent on Metal Scale															P
Percent on Tube															X
Direct Reading Metal Scale															S
Dual Direct Reading Metal Scales															D
Direct Reading on Tube															Y
Direct Reading Metal Scale, Percent on Tube															E
Panel Mounting															
Not required															X
Front Panel Mounted															Y
Rear (Flush) Panel Mounted															Z
Design Level															
															B
Size (Inches)															
Conn. Size		Tube Size													
1/2		1/2													H
3/4		3/4													J
3/4 (NPT only)		1													K
1		3/4													L
1 (FLGD only)		1													M
1 1/2		1 1/2													N
1 1/2		2													P
Fitting Material															
Brass/Bronze															B
316 Stainless Steel															C
PVC															F
Seal Material															
Packing Gland Design(10A4600)															
Neoprene packing with TEFLON liner															D
Neoprene packing only															E
O-ring Design(10A4500)															
Buna-N															F
VITON															H
Ethylene Propylene (EPR)															J
Connection Type															
NPT															B
Flat Face Flange Class 125 (Brass/Bronze and PVC)															C
Raised Face Flange Class 150 (316 Stainless Steel)															D
Alarms															
Not Required															X
High Alarm (Single Pole Double Throw)															B
Low Alarm (Single Pole Double Throw)															C
High & Low Alarm (Single Pole Double Throw)															D
High Alarm (Double Pole Double Throw)															E
Low Alarm (Double Pole Double Throw)															F
High & Low Alarm (Double Pole Double Throw)															G
High & High Alarm (Single Pole Double Throw)															H
Low & Low Alarm (Single Pole Double Throw)															J
High & High Alarm (Double Pole Double Throw)															K
Low & Low Alarm (Double Pole Double Throw)															L

2.0 INSTALLATION

2.1 Float Installation

The meter float is usually packaged separately and must be installed before the meter is placed in operation. Often a float is protected during shipment by a strip of rubber tape that is wrapped around the metering edge of the float. Remove this protective tape just before installing the float. The float may be installed into the flowmeter after it is connected in the pipe line by following a simple procedure discussed in the Maintenance Section 4.4.

2.2 Orienting Horizontal End Fittings

V/A MASTER flowmeters with horizontal end fittings are shipped from the factory with the end fitting connections oriented as ordered. If piping requirements necessitate a change both the inlet and outlet fittings can be rotated horizontally a full 360 degrees. Use the following procedures to re-orient the end fittings.

2.2.1 Model 10A4500

Loosen the two rear set screws that secure the end fittings. The location of these screws is shown in Figure 2-1 under the "STEP 2" procedure for the Model 10A4600 meter. Once the set screws have been loosened, a short length of dowel stick or a threaded pipe may be inserted into the end fitting (or in the case of a flanged connection, a pipe may be threaded into a companion flange) to be used as a lever to turn the end fittings to the desired position. After the end fitting has been rotated to the desired position, **re-tighten the set screws. The operator protection shield may have to be removed to re-align the scale on the tube. The operator protection shield must be installed before the meter is returned to service.**

2.2.2 Model 10A4600

In addition to the set screws of Model 10A4500, the Model 10A4600 meter also uses four packing compression screws that must be loosened before the end fitting may be turned. Loosen the two rear set screws and the packing gland screws before attempting to turn the end fittings (Refer to Figure 2-1). After loosening the rear set screws and the packing gland screws, **remove the packing gland screw(s) that interferes with the turning of the end fitting.** As shown in Figure 2-1, a short length of dowel stick or a threaded pipe may be inserted into the end fitting (or in the case of a flanged connection, a pipe may be threaded into a companion flange) to be used as a lever to turn the end fittings to the desired position. After the end fitting has been rotated to the desired position, **replace any packing gland screw(s) that were removed and tighten the set screws and packing gland screws. The operator protection shield may have to be removed to re-align the scale on the tube. The operator protection shield must be installed before the meter is returned to service.**

<p style="text-align: center;">CAUTION</p>

<p style="text-align: center;">Tighten the packing gland screws evenly to avoid strains on the glass tube. Tighten the packing glands only as tight as necessary to prevent leakage.</p>
--

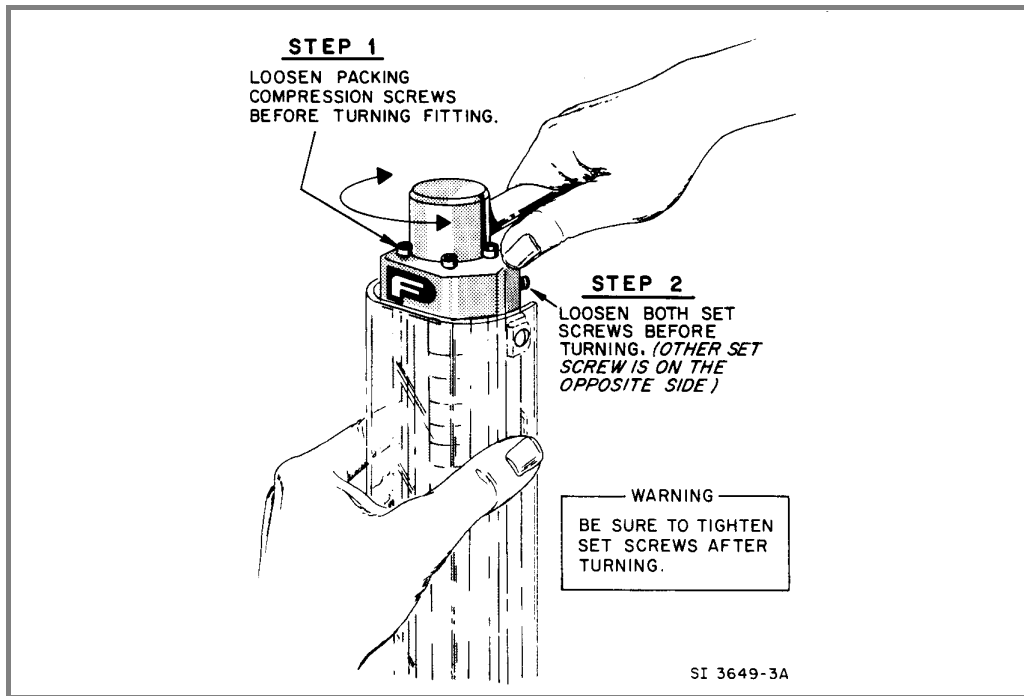

FIGURE 2-1. ROTATING THE END FITTING ON HORIZONTAL CONNECTIONS

2.3 Surge Chambers and Accumulators

A variable area flowmeter is less likely to be damaged, and can be most accurately read when the flow of fluid is smooth. However, it is occasionally necessary to install a meter in a line where reciprocating pumps or compressors are used. In these cases, surge chambers or accumulators are recommended to dampen the shock waves in the line.

Surge chambers, when used for liquid service, may have a gas padding pressure applied to the top of one chamber. When it is objectionable to have a gas in contact with the liquid, accumulators are used. Accumulators are similar to surge chambers except that they include a rubber bag (or other suitable material) in top of the chamber that isolates the gas from the liquid. The rubber bag in the accumulator is usually filled and sealed in the factory with a suitable gas to a pressure approximately 60% of the pumping pressure.

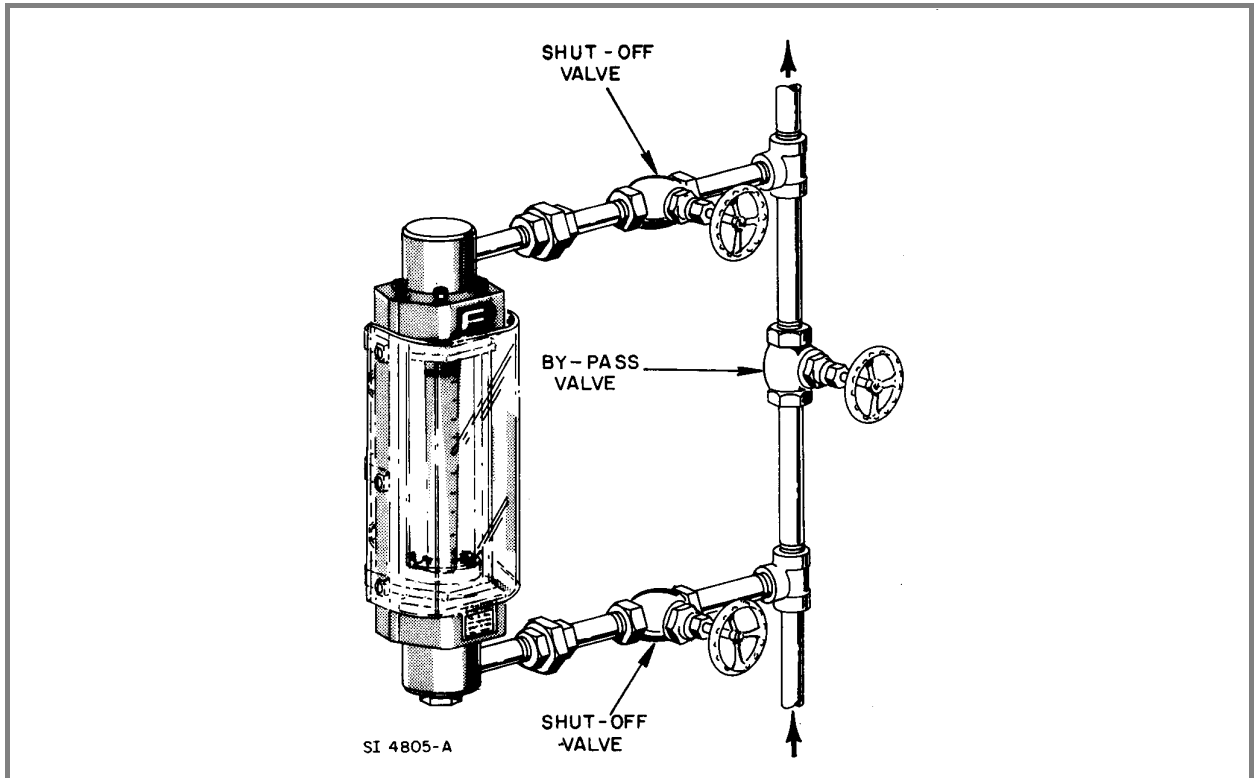

FIGURE 2-2. TYPICAL VERTICAL PIPING INSTALLATION USING HORIZONTAL CONNECTIONS

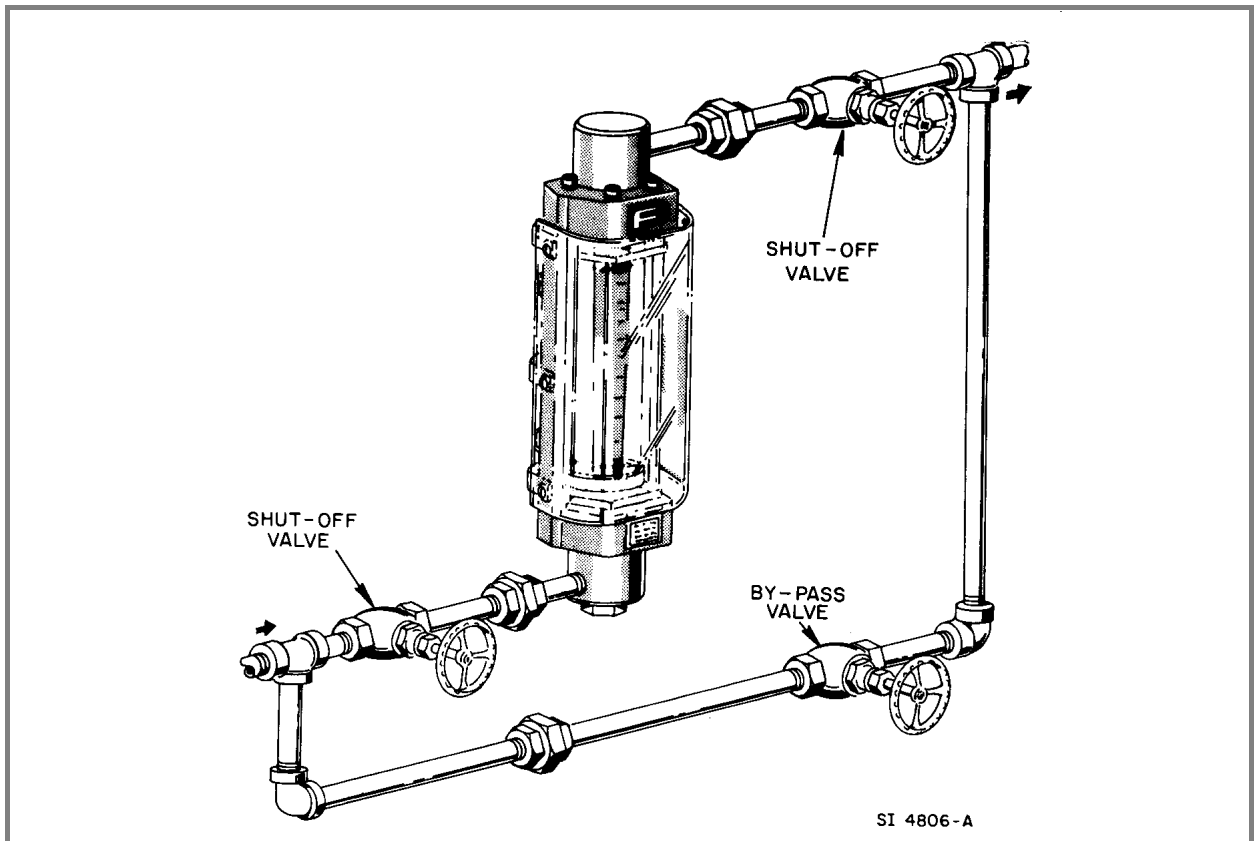

FIGURE 2-3. TYPICAL HORIZONTAL PIPING INSTALLATION

2.4 Mounting and Piping

2.4.1 General

The Series 10A4500/4600 V/A MASTER flowmeters may be installed directly in the pipe line or mounted on an instrument panel with optional mounting hardware. Regardless of the mounting method, the meter must be installed vertically with the outlet (highest scale graduation) at the top. Use a spirit level or plumb bob to check the vertical alignment.

Refer to Figure 2-4 for outline dimensions of the basic meter.

If possible, choose a location to mount the flowmeter that is well lighted so that the meter float is easily seen. To minimize the possibility of operator injury:

- The meter should never be subjected to excessive vibration.
- Avoid the use of quick acting valves or devices in the fluid stream to prevent shock waves from damaging the meter.
- The use of a pressure relief valve and/or rupture disc is recommended in the pipeline containing the flowmeter.

It is recommended that a conventional three valve manifold be installed around the meter. This manifold permits the process to be operated while the meter is being cleaned. Figures 2-2 and 2-3 illustrate typical piping installation of the flowmeter.

2.4.2 Liquid Service

When the flowmeter is used for liquid service, the inlet piping should be kept as large as economically practical; i.e., either the same size as the meter connection or one pipe size larger.

Control valves, elbows or tees may be used in the inlet or discharge piping without regard to the distance from the meter.

2.4.3 Gas Service

When the flowmeter is used for gas service, any reductions on the inlet and outlet piping should be kept to a minimum; i.e., either the same size as the meter connection or one pipe size smaller.

A control valve may be used in either the inlet or discharge piping. However, ABB Automation recommends the control valve be placed on the discharge side, especially when operated at close to the minimum psia rating. The control valve should be as close as possible to the meter outlet but after the location of any pressure measurement.

Since gas is compressible, the metering pressure must be known to determine correction factors that are applied to the indicated flow value. A pressure gauge (supplied by the user) should be placed on the downstream side of the meter (ahead of the control valve or any reduction in piping).

If the flowmeter is connected to a high pressure gas cylinder, use at least two stepdown pressure regulators.

2.4.4 Pipe Mounting

If the pipe lines are adequately supported, the flowmeter can be supported by the connection piping, except in the case of PVC fittings. A flowmeter with PVC process connections must be supported to relieve the strain on the connections. Alternately, the meter can be panel mounted to carry the weight of the meter.

2.4.5 Panel Mounting

2.4.5.1 General

The flowmeter may be mounted on either the front or rear of the panel. When the flowmeter is specified as rear panel mounted at time of purchase, the necessary hardware will be supplied by ABB Automation.

When the flowmeter is to be front panel mounted, nuts, bolts, and lockwashers for this use may be obtained from ABB Automation by ordering P/N 614B831U01 or purchased locally. All meter bodies are provided with mounting holes for front panel mounting.

2.4.5.2 Rear Panel Installation (refer to Figures 2-6 and 5-5)

A meter that is to be mounted on the rear of a panel (i.e., flush mounting) requires a cut-out and holes drilled to secure the meter, window (which is the operator protection shield), and bezel. The panel should be rigid, vertical and free from severe vibration. The minimum distance between adjacently mounted meters is determined by the piping requirements and the meter size.

WARNING
DO NOT OPERATE THE FLOWMETER WITHOUT THE OPERATOR PROTECTION SHIELD IN PLACE. TO DO SO MAY RESULT IN OPERATOR INJURY.

Refer to Figure 2-6 in order to make the necessary cut-out and holes, and proceed as follows:

- 1) Fasten the meter directly onto the rear of the panel using four 10-32 x 3/4 inch screws threaded into the tapped holes provided on the meter facing.
- 2) Attach the side shields and bar nut in place using four screws placed in the top and bottom holes of each bar nut. Verify that the side shields are positioned so as to be in contact with the sides of the meter body.
- 3) Fasten the bezel and window assembly onto the front of the panel by screwing the six remaining screws through the threaded holes provided on the bar nuts.
- 4) Connect the process piping to the meter to complete the installation. Piping for liquid service is discussed in Section 2.4.2 and gas service is discussed in Section 2.4.3.

2.4.5.3 Front Panel Installation (refer to Figure 2-5)

- 1) Remove the curved operator protection shield as follows:
 - Grasp both sides of the shield firmly with two hands
 - Squeeze one side of the shield inward to disengage the locking tabs while employing a rolling motion to raise the disengaged side of the shield out of the meter body
 - Move the shield away from the locking tabs on the other side and remove shield.
- 2) Remove the meter tube and float. This procedure is discussed in the Maintenance Section 4.
- 3) Remove the white plastic backing from behind the tube.
- 4) Enter the mounting screws through the front of the meter. Push the screws through the meter and panel. Install nuts and lockwashers from the rear of the panel to clamp the assembly.
- 5) Replace the white backing, meter tube and float and the operator protection shield to complete the procedure.

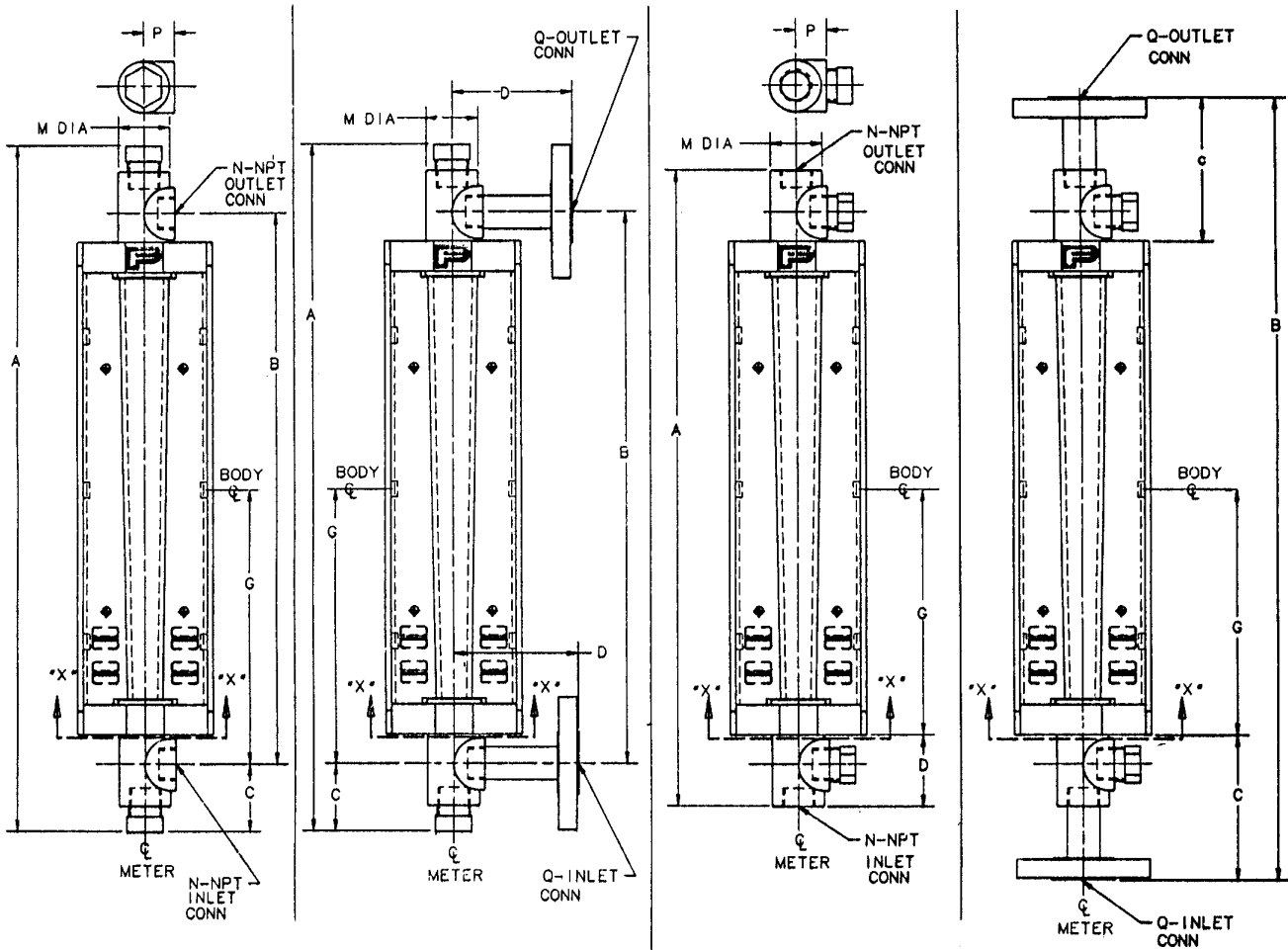

METER TUBE SIZE	1/2		3/4 TO 1		1-1/2 TO 2	
DIM	INCH	mm	INCH	mm	INCH	mm
A	19-5/16	490	21-3/16	538	26-7/16	671
B	16-1/2	419	17-1/2	445	20-1/2	521
C	1-13/32	37	1-27/32	47	2-31/32	75
D	3-1/2	89	4	102	5	127
E	3-3/8	86	4-3/8	111	5-11/16	144
F	2-5/8	67	3-27/64	87	4-7/8	124
G	8-1/4	210	8-3/4	222	10-1/4	260
L	1-1/2	38	1-59/64	49	2-5/8	67
M	1-1/4	32	1-1/2	38	2-1/2	64
N	1/2	13	3/4	19	1-1/2	38
P	3/4	19	1-1/8	29	1-7/8	48
Q	1/2	13	1	25	1-1/2	38

METER TUBE SIZE	1/2		3/4 TO 1		1-1/2 TO 2	
DIM	INCH	mm	INCH	mm	INCH	mm
A	18-9/16	471	20	508	24-5/16	618
B	20-5/8	524	22-1/8	562	27-11/16	703
C	2-21/32	68	3-5/32	80	5-7/32	133
D	1-5/8	41	2-3/32	53	3-17/32	90
E	3-3/8	86	4-3/8	111	5-11/16	144
F	2-5/8	67	3-27/64	87	4-7/8	124
G	7-21/32	194	7-29/32	201	8-5/8	219
L	1-1/2	38	1-59/64	49	2-5/8	67
M	1-1/4	32	1-1/2	38	2-1/2	64
N	1/2	13	3/4	19	1-1/2	38
P	3/4	19	1-1/8	29	1-7/8	48
Q	1/2	13	1	25	1-1/2	38

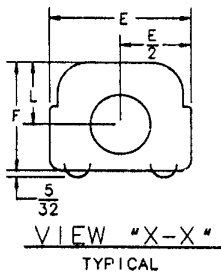

OD-10-2749

FIGURE 2-4. OUTLINE DIMENSIONS OF BASIC METER

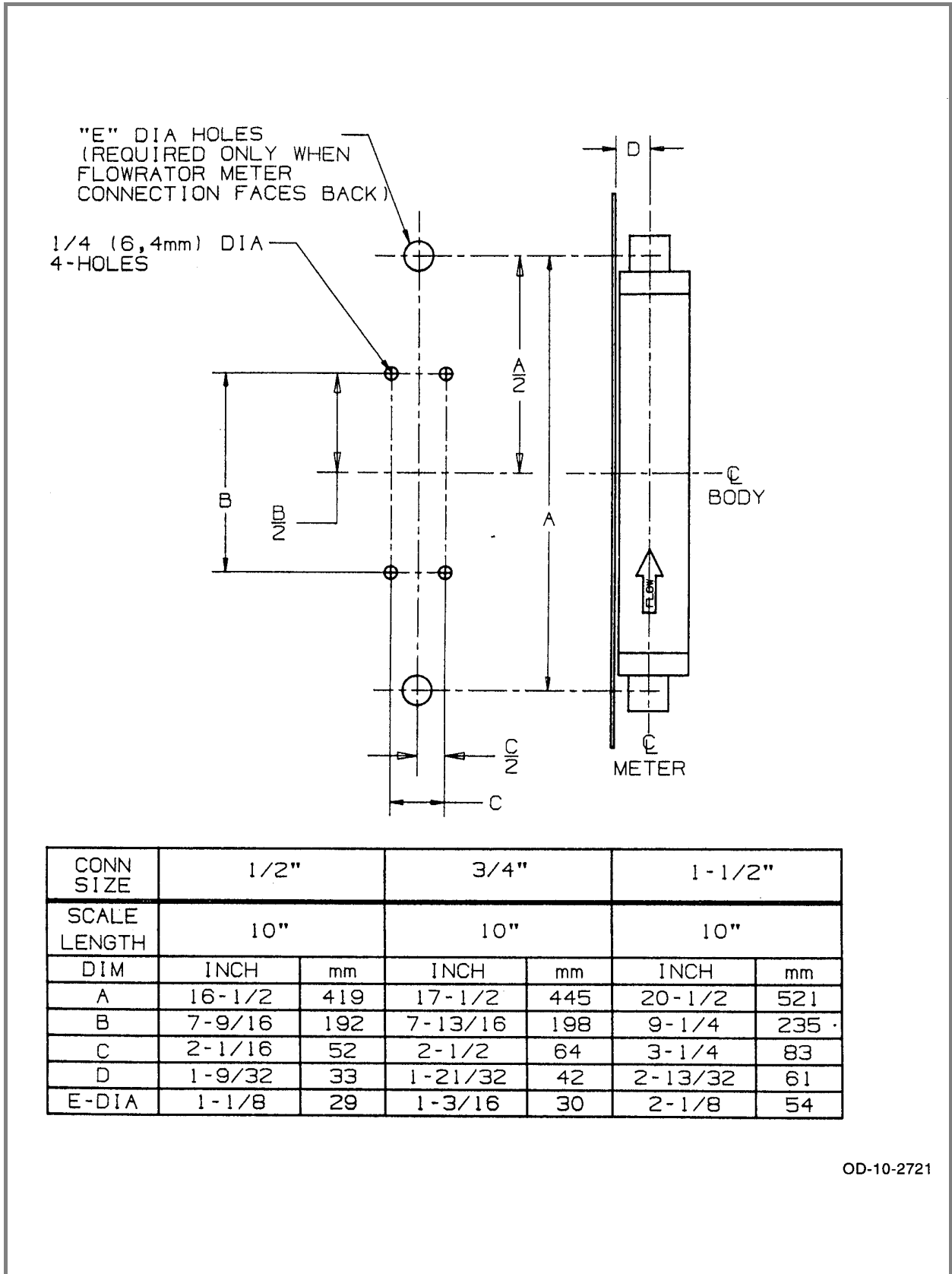

CONN SIZE	1/2"		3/4"		1-1/2"	
SCALE LENGTH	10"		10"		10"	
DIM	INCH	mm	INCH	mm	INCH	mm
A	16-1/2	419	17-1/2	445	20-1/2	521
B	7-9/16	192	7-13/16	198	9-1/4	235
C	2-1/16	52	2-1/2	64	3-1/4	83
D	1-9/32	33	1-21/32	42	2-13/32	61
E-DIA	1-1/8	29	1-3/16	30	2-1/8	54

OD-10-2721

FIGURE 2-5. OUTLINE DIMENSIONS FOR FRONT PANEL MOUNTING

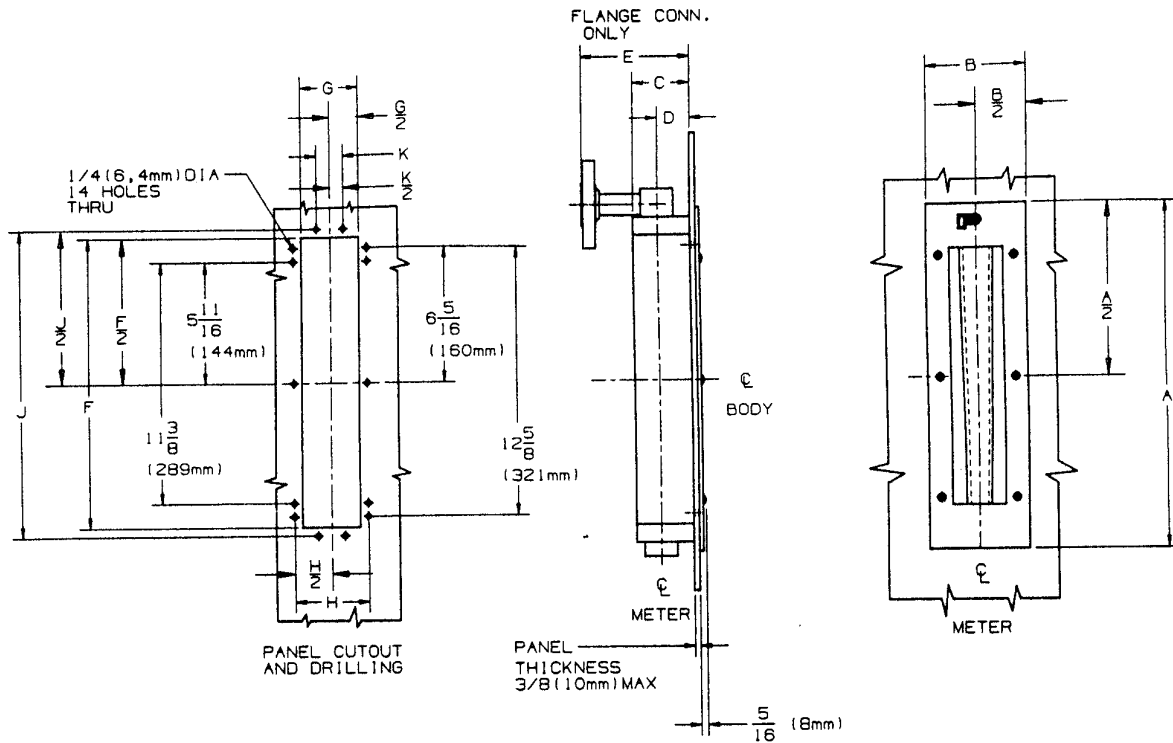

CONN SIZE	1/2"		3/4" & 1"		1-1/2"	
SCALE LENGTH	10"		10"		10"	
DIM	INCH	mm	INCH	mm	INCH	mm
A	16-3/16	411	16-3/16	411	17-3/4	451
B	4-9/16	116	5-1/4	133	6-1/8	156
C	2-5/8	67	3-7/16	87	4-7/8	124
D	1-1/2	38	1-15/16	49	2-5/8	67
E	5	127	5-15/16	151	7-5/8	194
F	13-5/8	346	13-7/8	352	15-5/16	389
G	2-11/16	68	3-3/8	86	4-1/4	108
H	3-7/16	87	4-1/8	105	5	127
J	14-7/16	367	14-13/16	376	16-1/4	413
K	1-1/4	32	1-11/16	43	2-3/8	60

OD-10-2723

FIGURE 2-6. OUTLINE DIMENSIONS FOR REAR PANEL MOUNTING

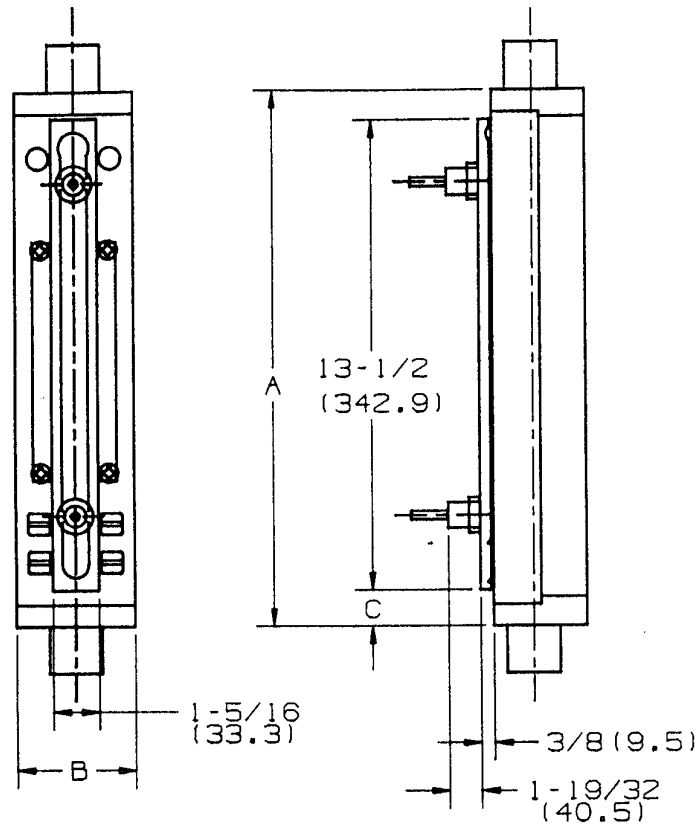

CONN SIZE	1/2"		3/4"-1"		1-1/2"-	
SCALE LENGTH	10"		10"		10"	
DIM	INCH	mm	INCH	mm	INCH	mm
A	15-5/16	389	15-13/16	402	17-1/4	438
B	3-3/8	86	4-3/8	111	5-11/16	145
C	1-3/64	27	1-13/32	36	1-13/16	46

NOTE

1) DIMENSIONS IN PARENTHESIS () ARE MILLIMETERS

OD-10-2720

FIGURE 2-7. OUTLINE DIMENSIONS FOR ALARM OPTION

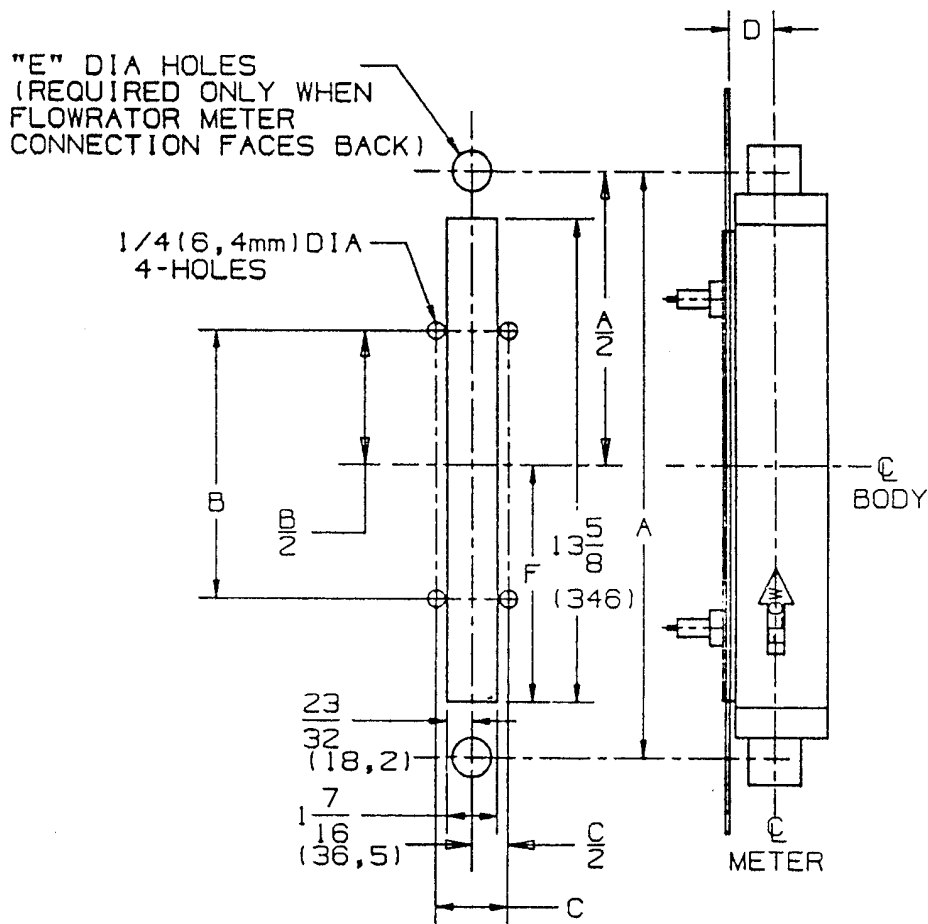

NOTE

1) DIMENSIONS IN PARENTHESIS () ARE MILLIMETERS

CONN SIZE	1/2"		3/4"		1-1/2"	
SCALE LENGTH	10"		10"		10"	
DIM	INCH	mm	INCH	mm	INCH	mm
A	16-1/2	419	17-1/2	445	20-1/2	521
B	7-9/16	192	7-13/16	198	9-1/4	235
C	2-1/16	52	2-1/2	64	3-1/4	33
D	1-9/32	33	1-21/32	42	2-13/32	61
E-DIA	1-1/8	29	1-3/16	30	2-1/8	54
F	6-43/64	170	6-9/16	167	6-7/8	175

OD-10-2722

FIGURE 2-8. OUTLINE DIMENSIONS FOR FRONT PANEL MOUNTING WITH ALARM OPTION

3.0 PLACING IN OPERATION

3.1 General

Prior to placing the meter into operation, the meter float must be installed as discussed in the Maintenance Section 4.4.

Meter readings must be taken from the scale at the graduation that coincides with the reading edge of the float. Figure 3-1 illustrates various types of floats and their reading edges.

The indicated value shown by the meter is accurate for the conditions stated on the meter scale. A liquid service meter is sensitive to density changes. A gas service meter is sensitive to specific gravity, pressure and temperature. When specified, a correction factor bulletin may be furnished for guided tubes. When necessary, calibration data is furnished for non-direct reading tubes.

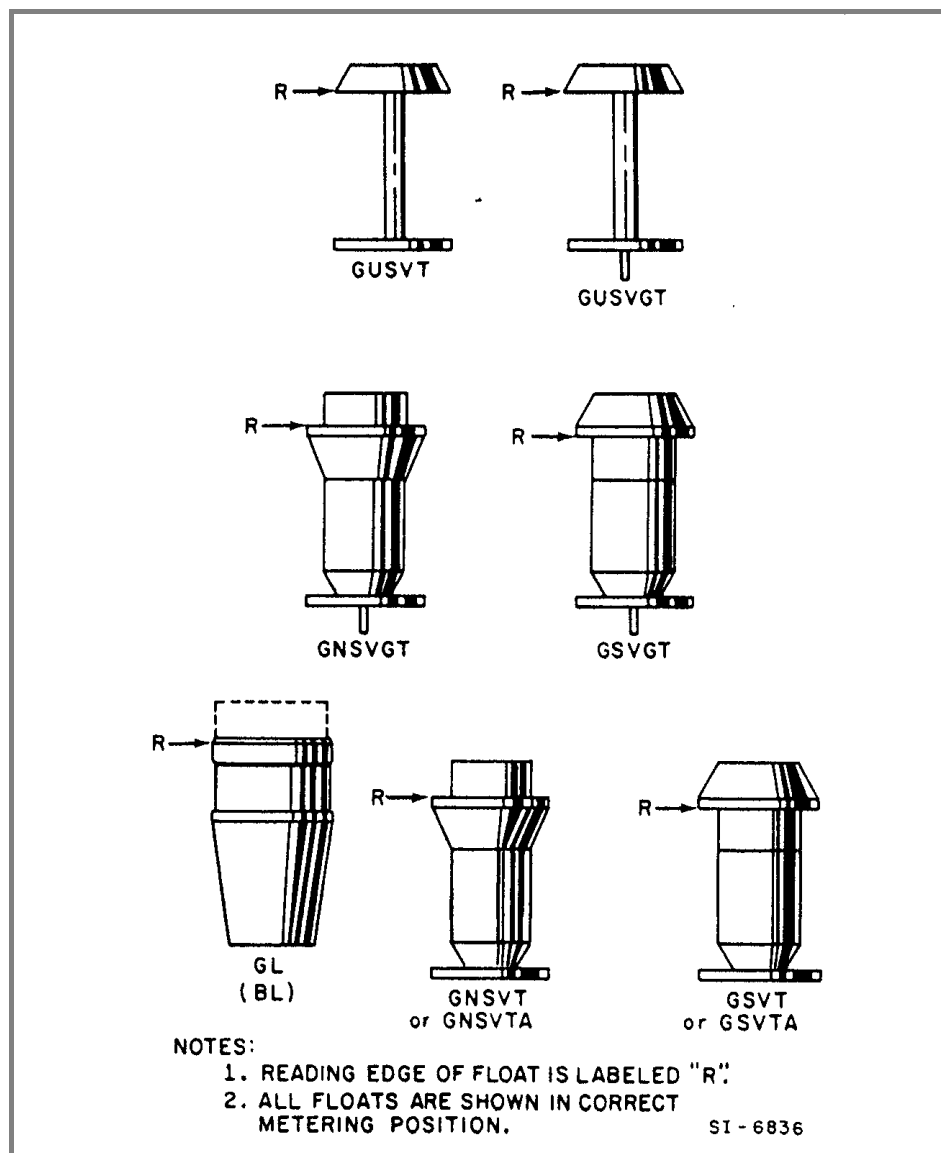

FIGURE 3-1. FLOAT READING EDGES

3.2 Liquid Service

To prevent meter tube breakage or damage to the meter float, the flow of liquid through the meter should be started gradually. Assuming that both the inlet and outlet shut-off valves are closed and that the bypass valve is open, proceed as follows:

- 1) Slowly open the shut-off valve at the meter inlet just enough to equalize the static pressure, then open the valve all the way.
- 2) Slowly open the shut-off valve at the meter outlet approximately 1/2 turn and allow the float to stabilize.
- 3) Gradually close the bypass valve and simultaneously open the shut-off valve at the meter outlet.

The shut-off valve at the meter outlet may be used to throttle the fluid flow, if desired. When it is desired to protect the meter from full line pressure or from pressure shock, the shut-off valve at the meter inlet may be used to throttle the flow.

3.3 Gas Service

The same start-up procedures apply for gas service as for liquid service (as discussed in Section 3.2, above) with one exception. See Section 2.4.3 for information on control/throttling valves.

Meters are designed for specific service conditions. However, if the meter is applied to a new gas service and float bounce occurs, it may be the result of:

- extreme low pressure operation
- heavy float
- operation near tube zero (at very low diameter ratios)
- having more than several pipe diameters between the flowmeter and the nearest valve or other throttling device

Refer service problems of this nature to the local ABB Automation service engineer.

3.4 Alarms

The alarm system consists of three integral components:

- The magnetic float.
- The sensor switch assembly(s).
- The alarm control amplifier.

Refer to Figures 2-7, 3-2 through 3-8 and 5-4 for typical alarm system installation.

Refer to Figure 3-13 for outline dimensions of the alarm control amplifier.

The sensor switches use the position of the float as their input signal for actuation.

To set the sensor switches:

- 1) Place the sensor(s) into the keyway at the top of the mounting bracket, with the flatwasher between the knurled nut and the mounting bracket. The minimum sensor must be inserted first when minimum and maximum sensors are used.
- 2) Slide the sensor to the desired minimum and/or maximum set-point position.
- 3) Adjust sensor(s) to within 1/32 inch (0.8 mm) of meter backplate as shown in Figure 3-2 and lock into place using the knurled nut.

To achieve an accurate alarm set point, the sensor switches should be set under flow conditions while verifying alarm operation at desired minimum and/or maximum set-points.

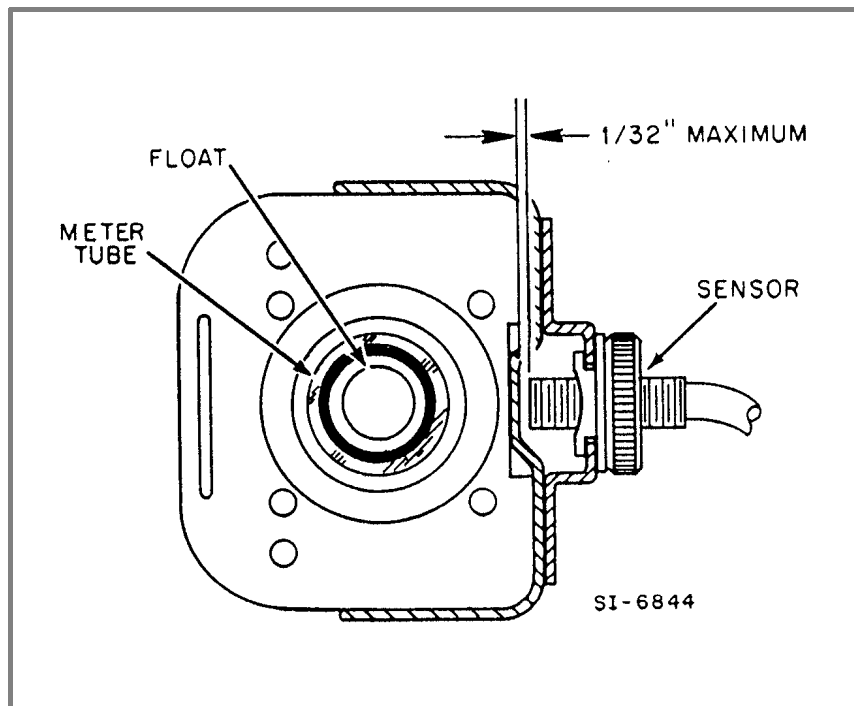

FIGURE 3-2. ALARM SENSOR POSITIONING

3.4.1 Alarm Specifications

Non-Hazardous locations:

Wiring shall comply with the National Electrical Code (ANSI/NFPA 70) and local code requirements.

Hazardous locations:

WARNING
Prior to installation the user shall determine that the glass tube V/A meter is suitable for use in the specific hazardous location.

The control amplifier has intrinsically safe circuit connections. However, the amplifier itself is only suitable for non-hazardous locations. Wiring between sensor switches and the control amplifier shall be installed in accordance with ANSI/ISA RP 12.6 Installation of Intrinsically Safe Systems for Hazardous (Classified) Locations.

Amplifier relay contacts are unpowered and are rated at 4 A, 250 V. Contacts are shown de-energized (refer to applicable Figures 3-3 through 3-12). Contacts are not to be paralleled to increase current rating.

TABLE 3-1 CABLE LENGTHS

TRANSMITTER LOCATION	MAXIMUM LENGTH (Note 1)*
Non-Hazardous or Div. 2	2.5 mi. (4 km)
Class I, Div. I, Groups A and B	6000 ft. (1829 m)
Class I, Div. I, Groups C and D	2.5 mi. (4 km)
Class II, Div. I, Groups E, F and G	2.5 mi. (4 km)

*Cable Capacitance: less than 60 picofarad/ft (197 picofarad/m)
 Inductance: less than 0.2 microhenry/ft (0.656 microhenry/m)

Note:

1. Field wiring between sensor switches and control amplifiers should be twisted pair wire, #22 AWG or larger. Maximum cable length shall be per Table 3-1. The sensor switches are provided with five feet (1.5 m) of cable. All additional field wiring is supplied by user.

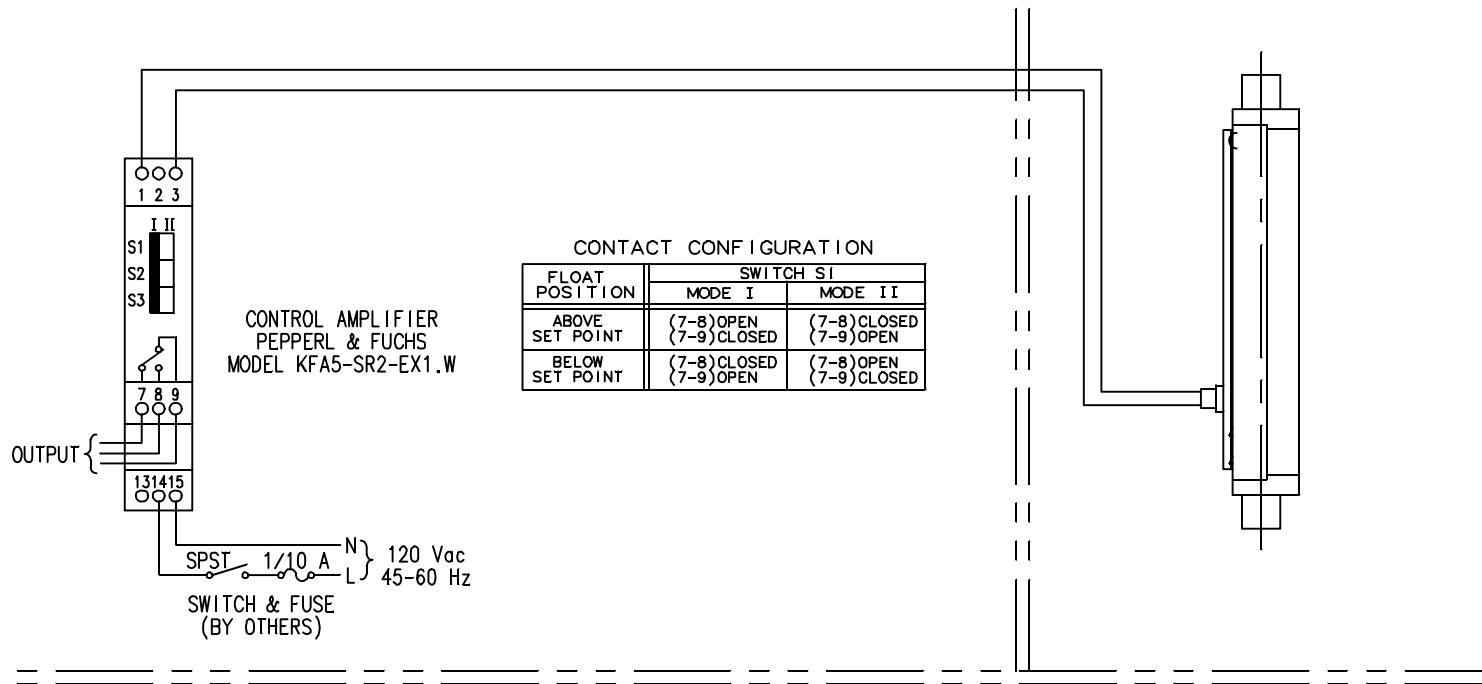

ELECTRICAL INSTALLATION REQUIREMENTS

NON-HAZARDOUS LOCATIONS:
WIRING SHALL COMPLY WITH THE NATIONAL ELECTRICAL CODE(ANSI/NFPA 70) AND LOCAL CODE REQUIREMENTS.

HAZARDOUS LOCATIONS:

-WARNING-
PRIOR TO INSTALLATION, THE USER SHALL DETERMINE THAT THE GLASS TUBE V/A METER IS SUITABLE FOR USE IN THE SPECIFIC HAZARDOUS LOCATION.

THE CONTROL AMPLIFIER HAS INTRINSICALLY SAFE CIRCUIT CONNECTIONS, HOWEVER THE AMPLIFIER ITSELF IS ONLY SUITABLE FOR NON-HAZARDOUS LOCATIONS. WIRING BETWEEN SENSOR SWITCHES AND THE CONTROL AMPLIFIER SHALL BE INSTALLED IN ACCORDANCE WITH ANSI/ISA RP 12.6. INSTALLATION OF INTRINSICALLY SAFE SYSTEMS FOR HAZARDOUS (CLASSIFIED) LOCATIONS.

NOTES:

1. FIELD WIRING BETWEEN SENSOR SWITCHES AND CONTROL AMPLIFIER(S) SHOULD BE TWISTED PAIR, 25 AWG OR LARGER. MAXIMUM CABLE LENGTH PER TABLE 1. THE SENSOR SWITCHES ARE PROVIDED WITH 1.5m (5 FT) OF CABLE. ALL ADDITIONAL FIELD WIRING BY OTHERS.
2. AMPLIFIER RELAY CONTACTS ARE UNPOWERED AND ARE RATED AT 2A, 250V. CONTACTS ARE SHOWN DE-ENERGIZED. CONTACTS ARE NOT TO BE PARALLELED TO INCREASE CURRENT RATING.

TABLE 1 CABLE LENGTH

TRANSMITTER LOCATION	MAXIMUM LENGTH (NOTE 1)	
NON-HAZARDOUS OR DIV 2	1mi	1.5km
CLASS I, DIV 1, GROUPS A & B	3000ft	900m
CLASS I, DIV 1, GROUP C & D CLASS II, DIV 1, GROUP E, F & G	1mi	1.5km

CABLE CAPACITANCE: LESS THAN 60 picofarad/ft (197 picofarad/m)

INDUCTANCE: LESS THAN 0.2 microhenry/ft (0.656 microhenry/m)

ID-10-1124

FIGURE 3-3. SINGLE (LOW) ALARM SINGLE POLE DOUBLE THROW RELAY OUTPUT

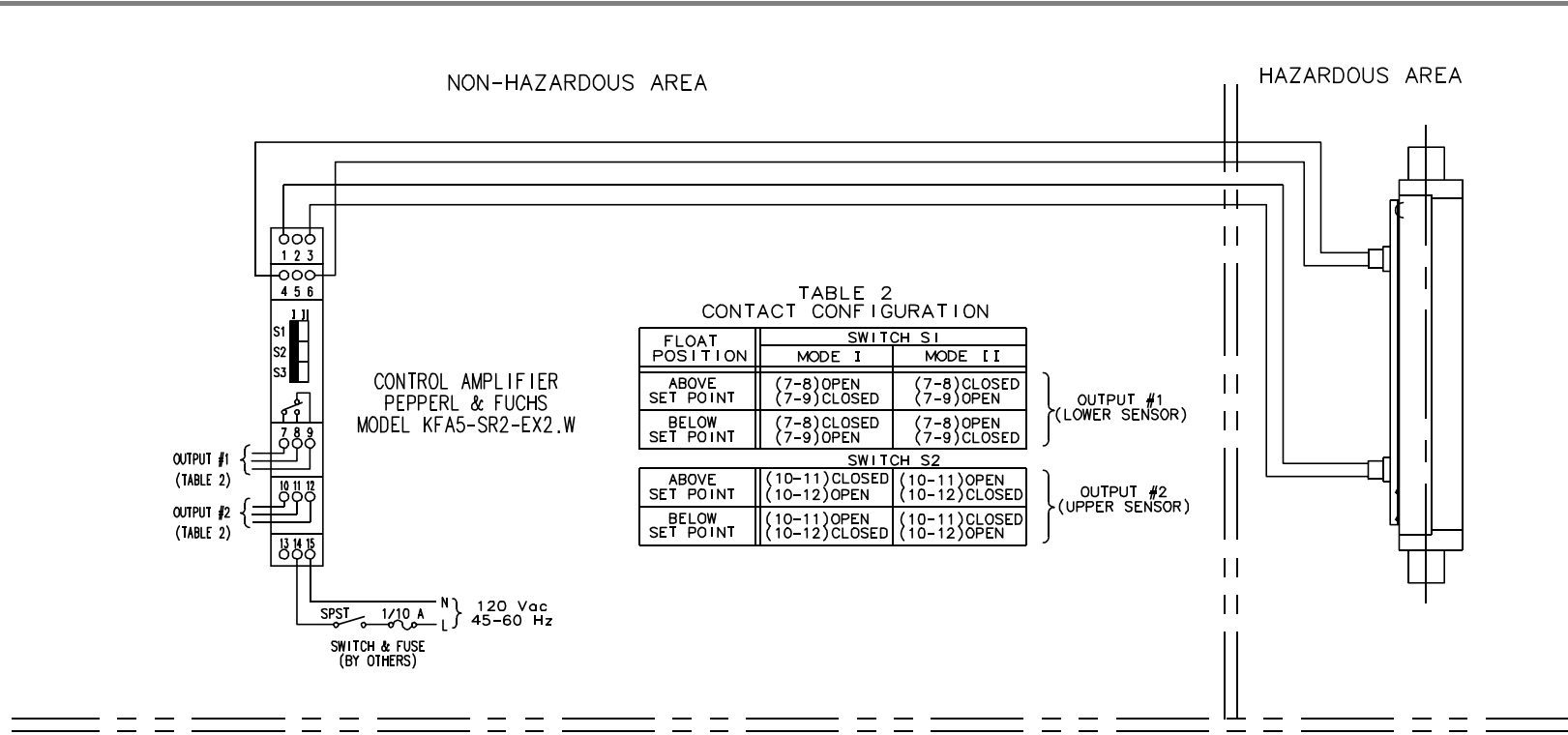

ELECTRICAL INSTALLATION REQUIREMENTS

NON-HAZARDOUS LOCATIONS:
WIRING SHALL COMPLY WITH THE NATIONAL ELECTRICAL CODE(ANSI/NFPA 70) AND LOCAL CODE REQUIREMENTS.

HAZARDOUS LOCATIONS:

-WARNING-
PRIOR TO INSTALLATION, THE USER SHALL DETERMINE THAT THE GLASS TUBE V/A METER IS SUITABLE FOR USE IN THE SPECIFIC HAZARDOUS LOCATION.

THE CONTROL AMPLIFIER HAS INTRINSICALLY SAFE CIRCUIT CONNECTIONS, HOWEVER THE AMPLIFIER ITSELF IS ONLY SUITABLE FOR NON-HAZARDOUS LOCATIONS. WIRING BETWEEN SENSOR SWITCHES AND THE CONTROL AMPLIFIER SHALL BE INSTALLED IN ACCORDANCE WITH ANSI/ISA RP 12.6, INSTALLATION OF INTRINSICALLY SAFE SYSTEMS FOR HAZARDOUS (CLASSIFIED) LOCATIONS.

NOTES:

1. FIELD WIRING BETWEEN SENSOR SWITCHES AND CONTROL AMPLIFIER(S) SHOULD BE TWISTED PAIR, 25 AWG OR LARGER. MAXIMUM CABLE LENGTH PER TABLE 1. THE SENSOR SWITCHES ARE PROVIDED WITH 1.5m (5 FT) OF CABLE. ALL ADDITIONAL FIELD WIRING BY OTHERS.
2. AMPLIFIER RELAY CONTACTS ARE UNPOWERED AND ARE RATED AT 2A, 250V. CONTACTS ARE SHOWN DE-ENERGIZED. CONTACTS ARE NOT TO BE PARALLELED TO INCREASE CURRENT RATING.

TABLE 1 CABLE LENGTH

TRANSMITTER LOCATION	MAXIMUM LENGTH (NOTE 1)	
NON-HAZARDOUS OR DIV 2	1mi	1.5km
CLASS I, DIV 1, GROUPS A & B	3000ft	900m
CLASS I, DIV 1, GROUP C & D CLASS II, DIV 1, GROUP E, F & G	1mi	1.5km

CABLE CAPACITANCE: LESS THAN 60 picofarad/ft (197 picofarad/m)

INDUCTANCE: LESS THAN 0.2 microhenry/ft (0.656 microhenry/m)

ID-10-1125 REV 0

FIGURE 3-4. DUAL (HIGH/LOW) ALARM SINGLE POLE DOUBLE THROW RELAY OUTPUT

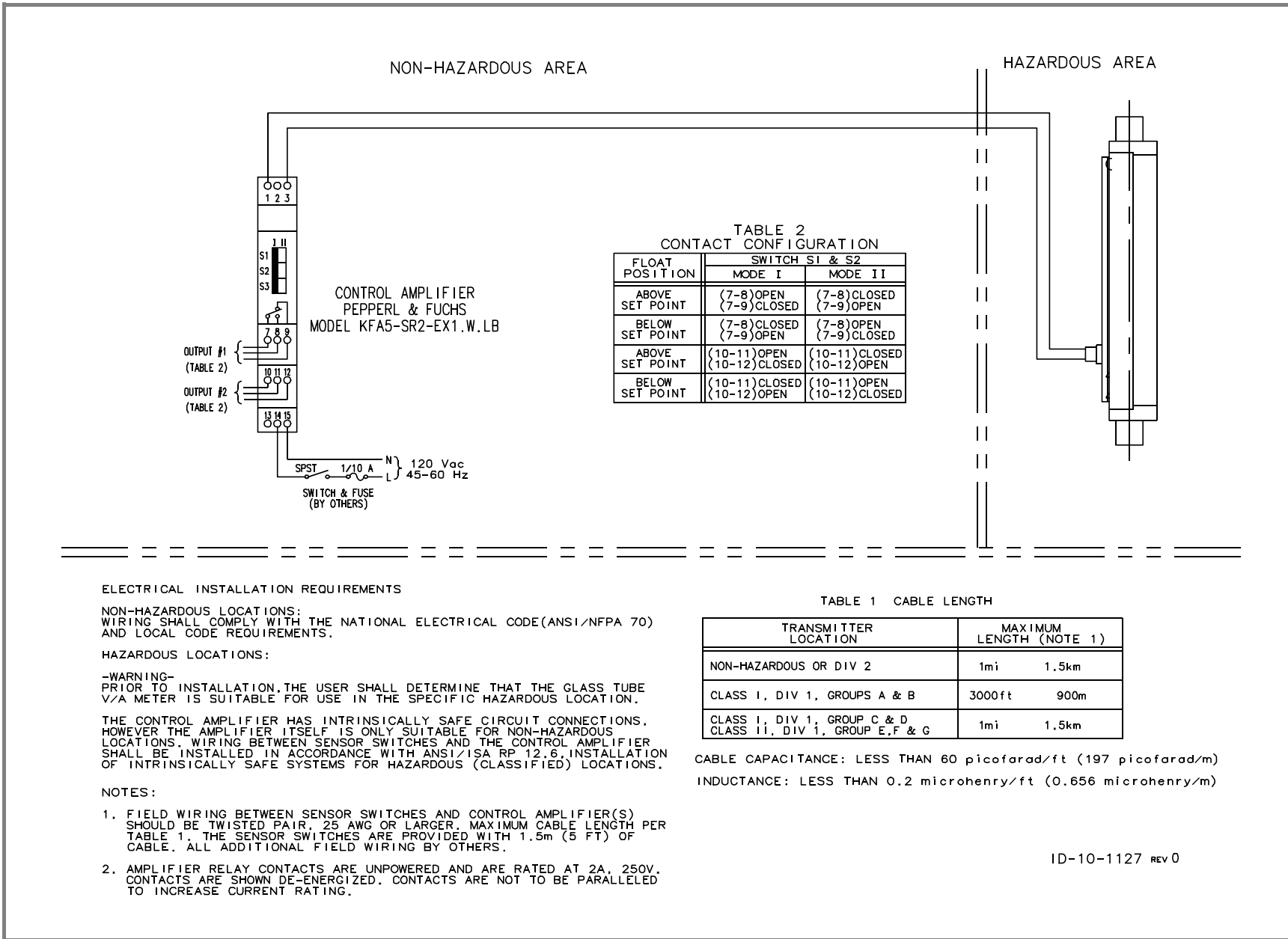
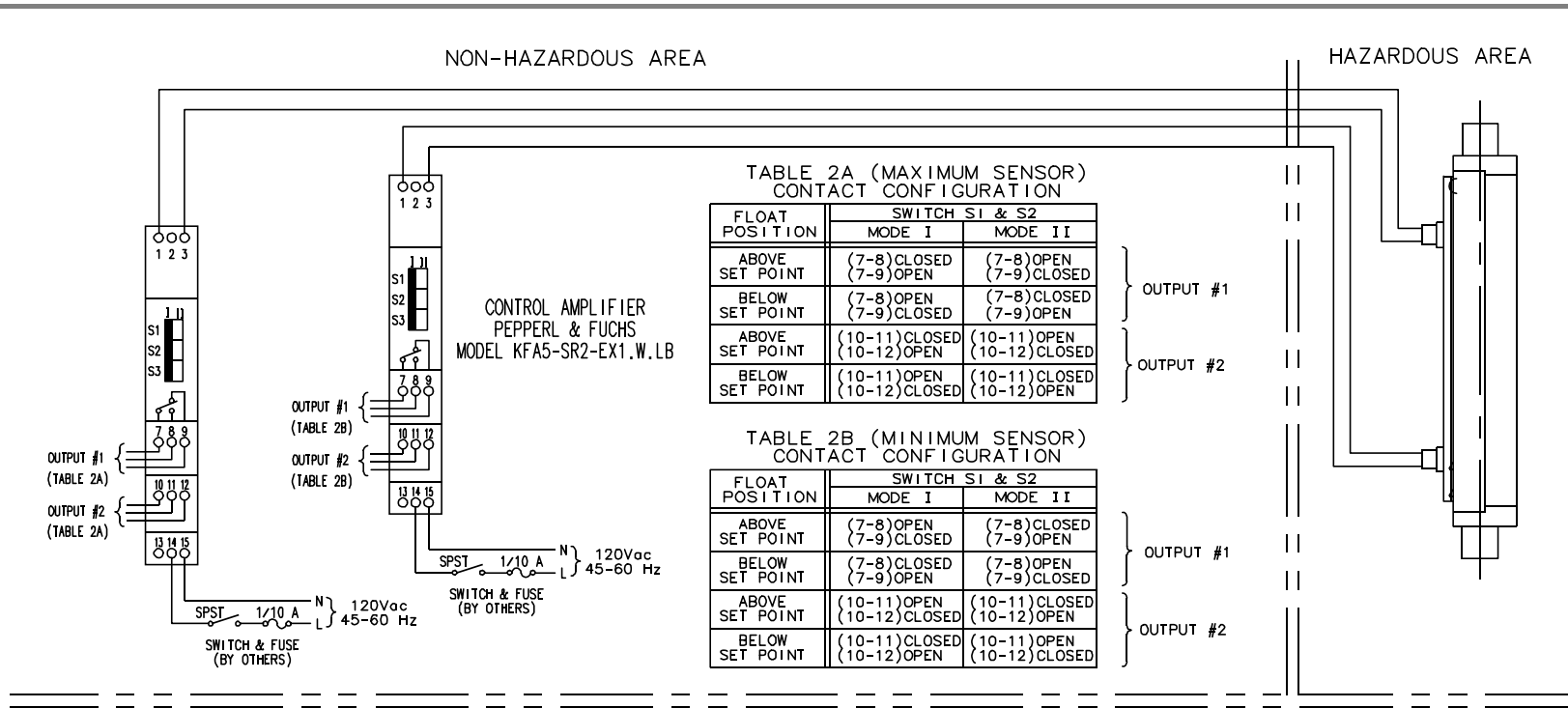

FIGURE 3-5. SINGLE (LOW) ALARM DOUBLE POLE DOUBLE THROW RELAY OUTPUT



ELECTRICAL INSTALLATION REQUIREMENTS

NON-HAZARDOUS LOCATIONS:
WIRING SHALL COMPLY WITH THE NATIONAL ELECTRICAL CODE(ANSI/NFPA 70)
AND LOCAL CODE REQUIREMENTS.

HAZARDOUS LOCATIONS:

-WARNING-
PRIOR TO INSTALLATION, THE USER SHALL DETERMINE THAT THE GLASS TUBE
V/A METER IS SUITABLE FOR USE IN THE SPECIFIC HAZARDOUS LOCATION.

THE CONTROL AMPLIFIER HAS INTRINSICALLY SAFE CIRCUIT CONNECTIONS,
HOWEVER THE AMPLIFIER ITSELF IS ONLY SUITABLE FOR NON-HAZARDOUS
LOCATIONS. WIRING BETWEEN SENSOR SWITCHES AND THE CONTROL AMPLIFIER
SHALL BE INSTALLED IN ACCORDANCE WITH ANSI/ISA RP 12.6, INSTALLATION
OF INTRINSICALLY SAFE SYSTEMS FOR HAZARDOUS (CLASSIFIED) LOCATIONS.

NOTES:

1. FIELD WIRING BETWEEN SENSOR SWITCHES AND CONTROL AMPLIFIER(S)
SHOULD BE TWISTED PAIR, 25 AWG OR LARGER. MAXIMUM CABLE LENGTH PER
TABLE 1. THE SENSOR SWITCHES ARE PROVIDED WITH 1.5m (5 FT) OF
CABLE. ALL ADDITIONAL FIELD WIRING BY OTHERS.
2. AMPLIFIER RELAY CONTACTS ARE UNPOWERED AND ARE RATED AT 2A, 250V.
CONTACTS ARE SHOWN DE-ENERGIZED. CONTACTS ARE NOT TO BE PARALLELED
TO INCREASE CURRENT RATING.

TABLE 1 CABLE LENGTH

TRANSMITTER LOCATION	MAXIMUM LENGTH (NOTE 1)	
NON-HAZARDOUS OR DIV 2	1mi	1.5km
CLASS I, DIV 1, GROUPS A & B	3000ft	900m
CLASS I, DIV 1, GROUP C & D CLASS II, DIV 1, GROUP E, F & G	1mi	1.5km

CABLE CAPACITANCE: LESS THAN 60 picofarad/ft (197 picofarad/m)

INDUCTANCE: LESS THAN 0.2 microhenry/ft (0.656 microhenry/m)

ID-10-1128 REV 0

FIGURE 3-6. DUAL (HIGH/LOW) ALARM DOUBLE POLE DOUBLE THROW RELAY OUTPUT

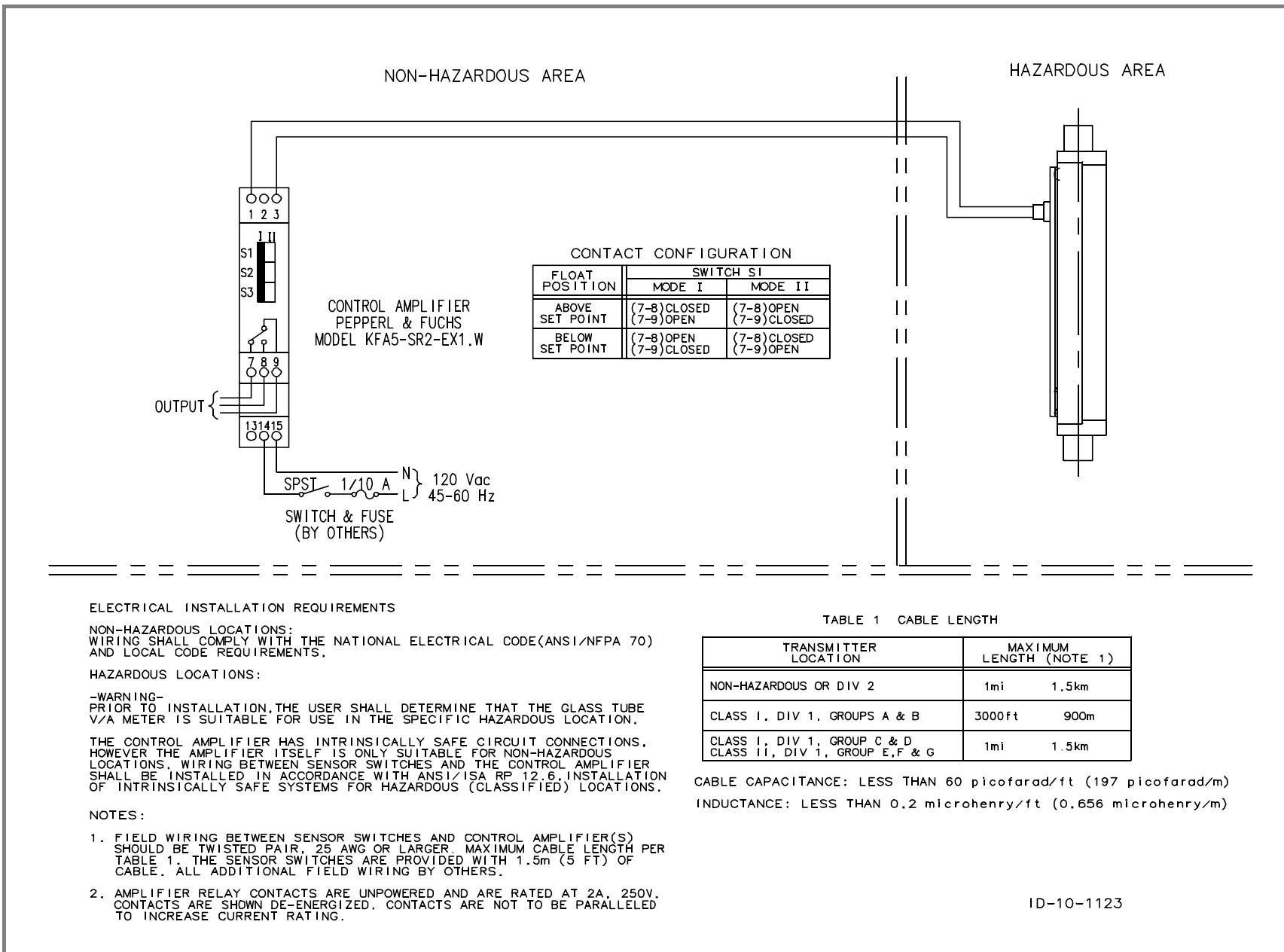

FIGURE 3-7. SINGLE (HIGH) ALARM SINGLE POLE DOUBLE THROW RELAY OUTPUT

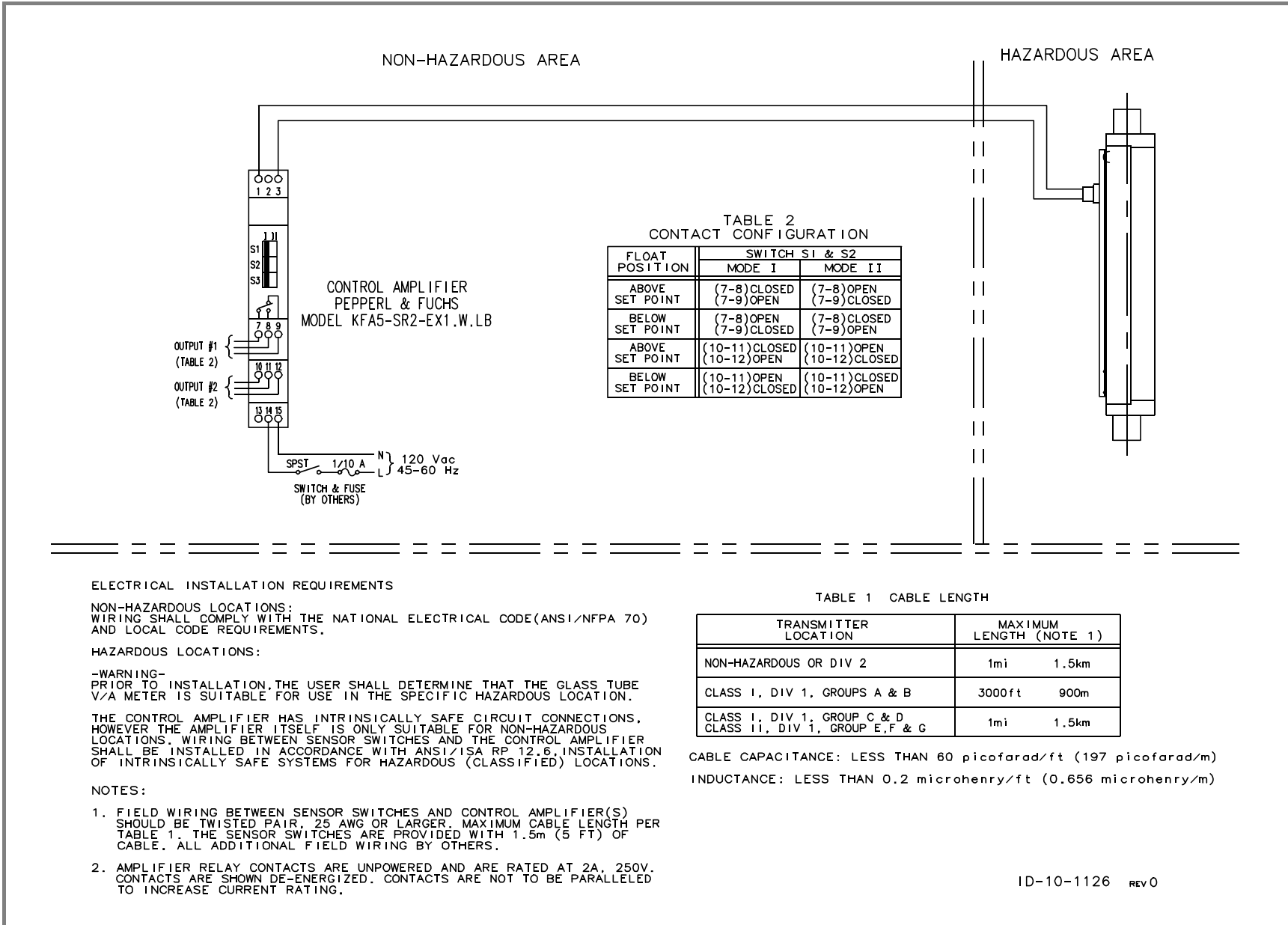

FIGURE 3-8. SINGLE (HIGH) ALARM DOUBLE POLE DOUBLE THROW RELAY OUTPUT

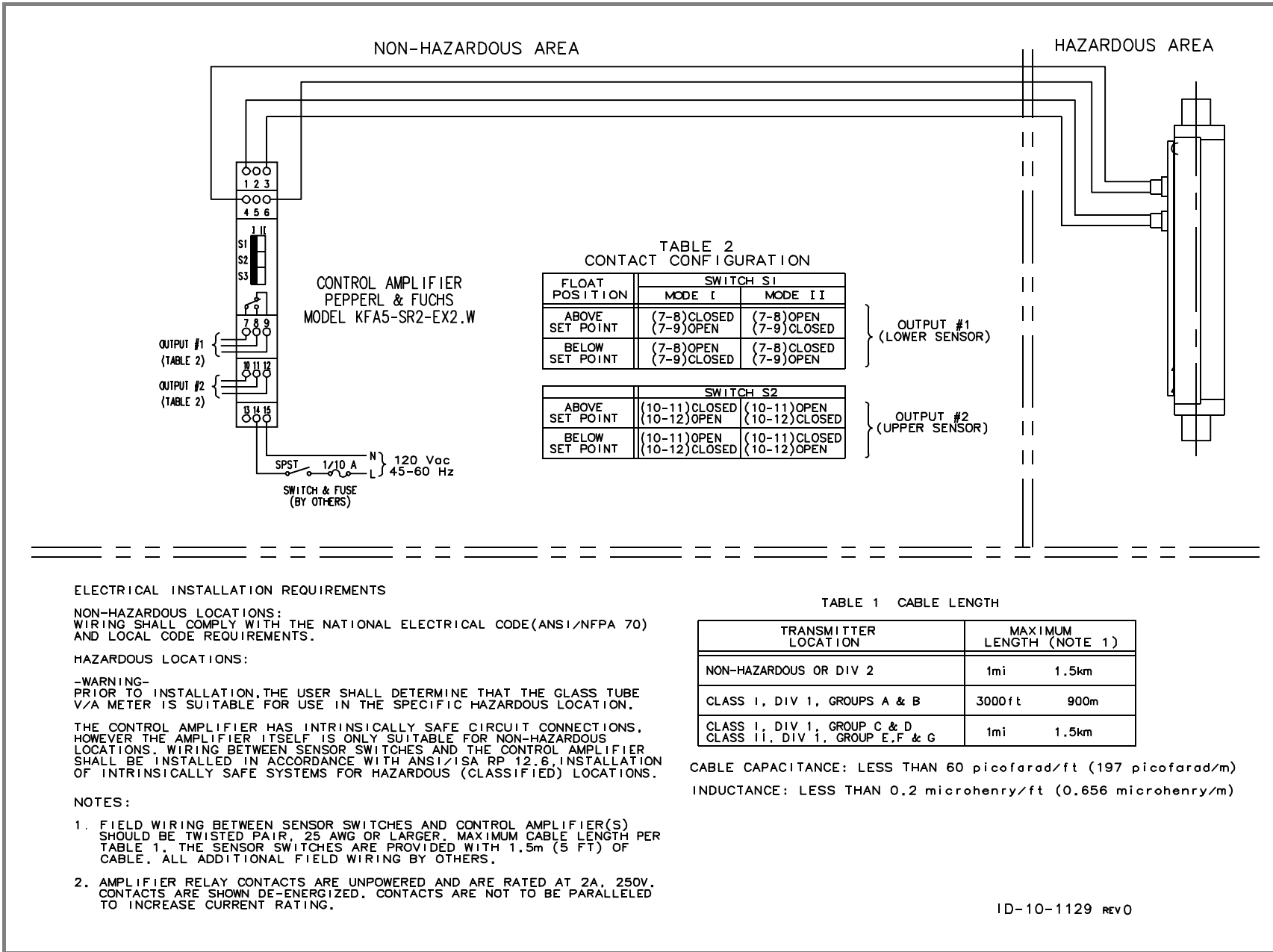
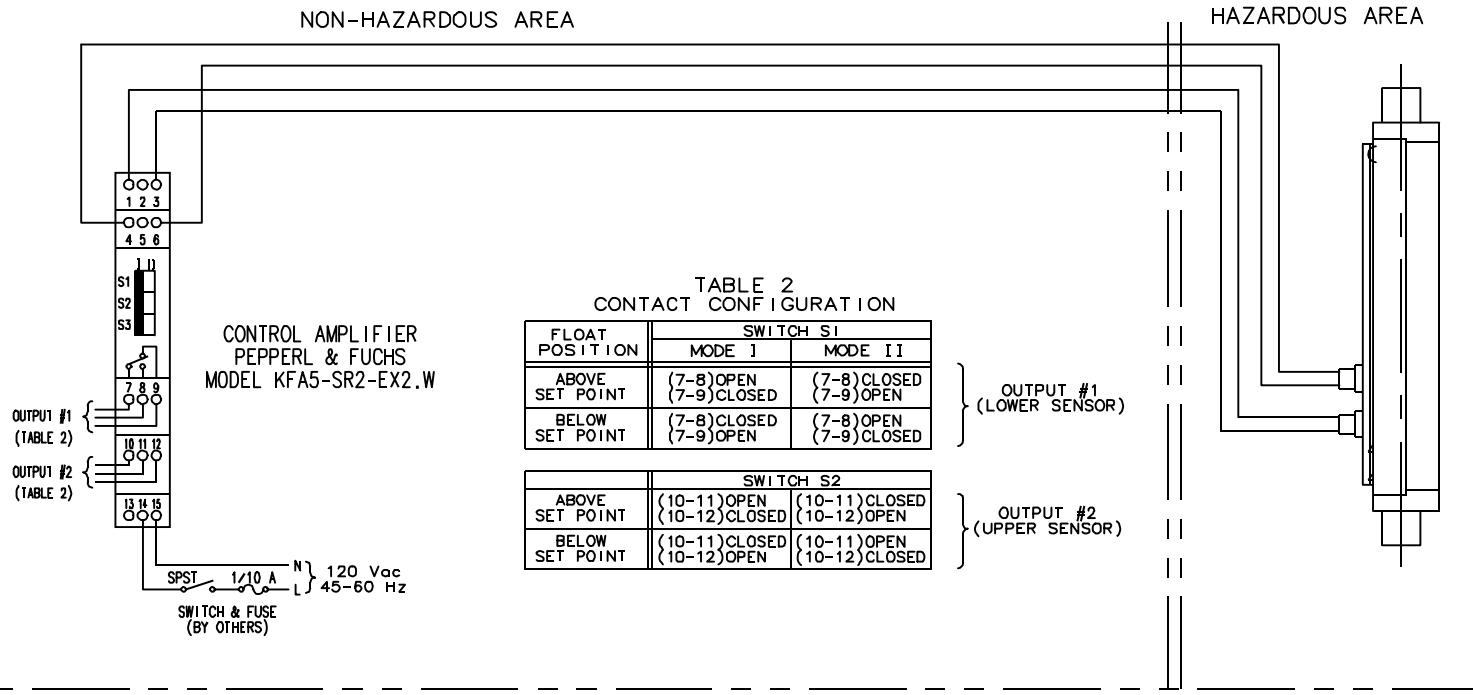

FIGURE 3-9. DUAL (HIGH/HIGH) ALARM SINGLE POLE DOUBLE THROW RELAY OUTPUT



ELECTRICAL INSTALLATION REQUIREMENTS

NON-HAZARDOUS LOCATIONS:
WIRING SHALL COMPLY WITH THE NATIONAL ELECTRICAL CODE(ANSI/NFPA 70) AND LOCAL CODE REQUIREMENTS.

HAZARDOUS LOCATIONS:

-WARNING-
PRIOR TO INSTALLATION, THE USER SHALL DETERMINE THAT THE GLASS TUBE V/A METER IS SUITABLE FOR USE IN THE SPECIFIC HAZARDOUS LOCATION.

THE CONTROL AMPLIFIER HAS INTRINSICALLY SAFE CIRCUIT CONNECTIONS. HOWEVER THE AMPLIFIER ITSELF IS ONLY SUITABLE FOR NON-HAZARDOUS LOCATIONS. WIRING BETWEEN SENSOR SWITCHES AND THE CONTROL AMPLIFIER SHALL BE INSTALLED IN ACCORDANCE WITH ANSI/ISA RP-12.6. INSTALLATION OF INTRINSICALLY SAFE SYSTEMS FOR HAZARDOUS (CLASSIFIED) LOCATIONS.

NOTES:

1. FIELD WIRING BETWEEN SENSOR SWITCHES AND CONTROL AMPLIFIER(S) SHOULD BE TWISTED PAIR, 25 AWG OR LARGER. MAXIMUM CABLE LENGTH PER TABLE 1. THE SENSOR SWITCHES ARE PROVIDED WITH 1.5m (5 FT) OF CABLE. ALL ADDITIONAL FIELD WIRING BY OTHERS.
2. AMPLIFIER RELAY CONTACTS ARE UNPOWERED AND ARE RATED AT 2A, 250V. CONTACTS ARE SHOWN DE-ENERGIZED. CONTACTS ARE NOT TO BE PARALLELED TO INCREASE CURRENT RATING.

TABLE 1 CABLE LENGTH

TRANSMITTER LOCATION	MAXIMUM LENGTH (NOTE 1)	
NON-HAZARDOUS OR DIV 2	1mi	1.5km
CLASS I, DIV 1, GROUPS A & B	3000ft	900m
CLASS I, DIV 1, GROUP C & D CLASS II, DIV 1, GROUP E, F & G	1mi	1.5km

CABLE CAPACITANCE: LESS THAN 60 picofarad/ft (197 picofarad/m)

INDUCTANCE: LESS THAN 0.2 microhenry/ft (0.656 microhenry/m)

ID-10-1130 REV 0

FIGURE 3-10. DUAL (LOW/LOW) ALARM SINGLE POLE DOUBLE THROW RELAY OUTPUT

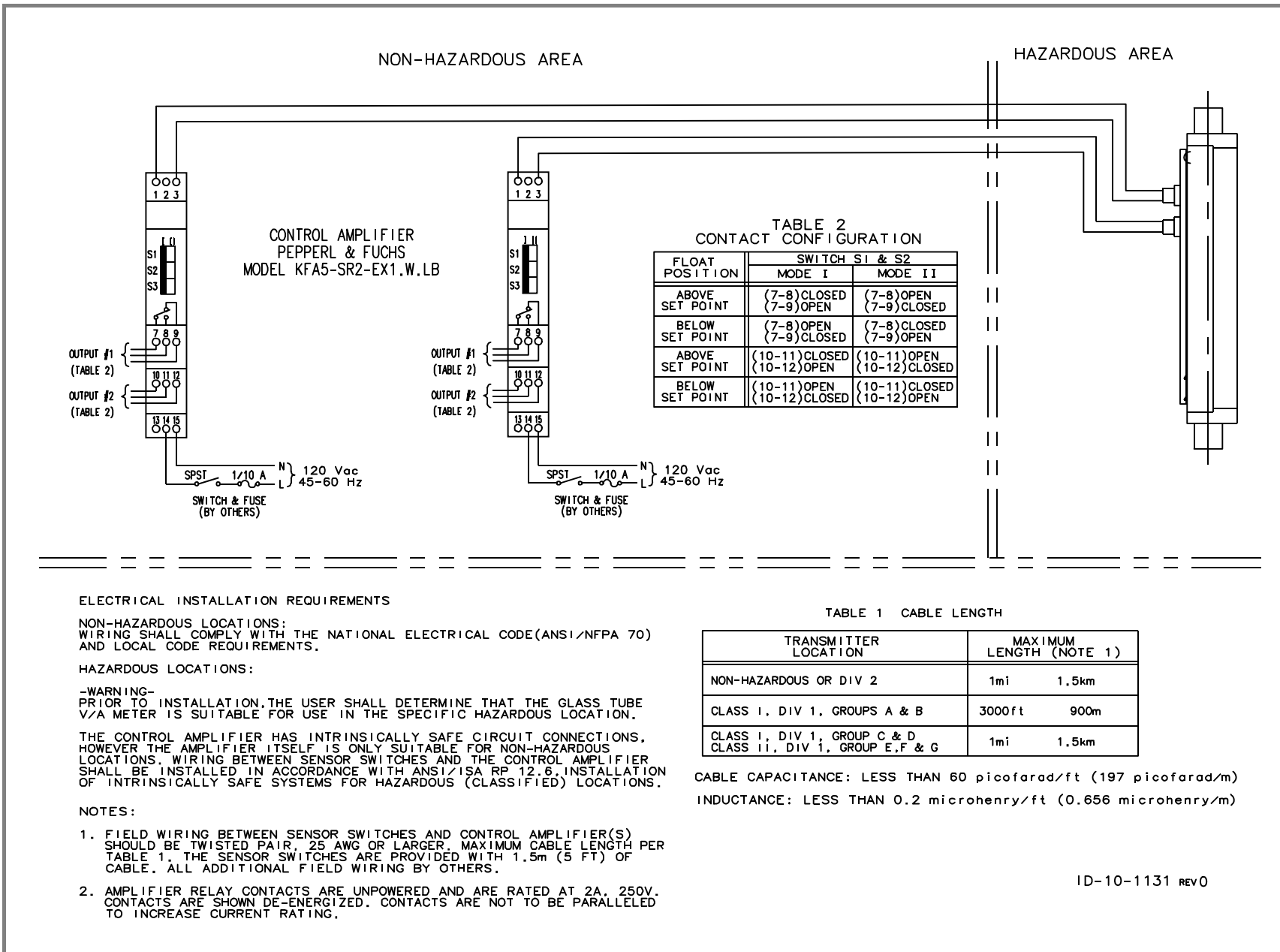
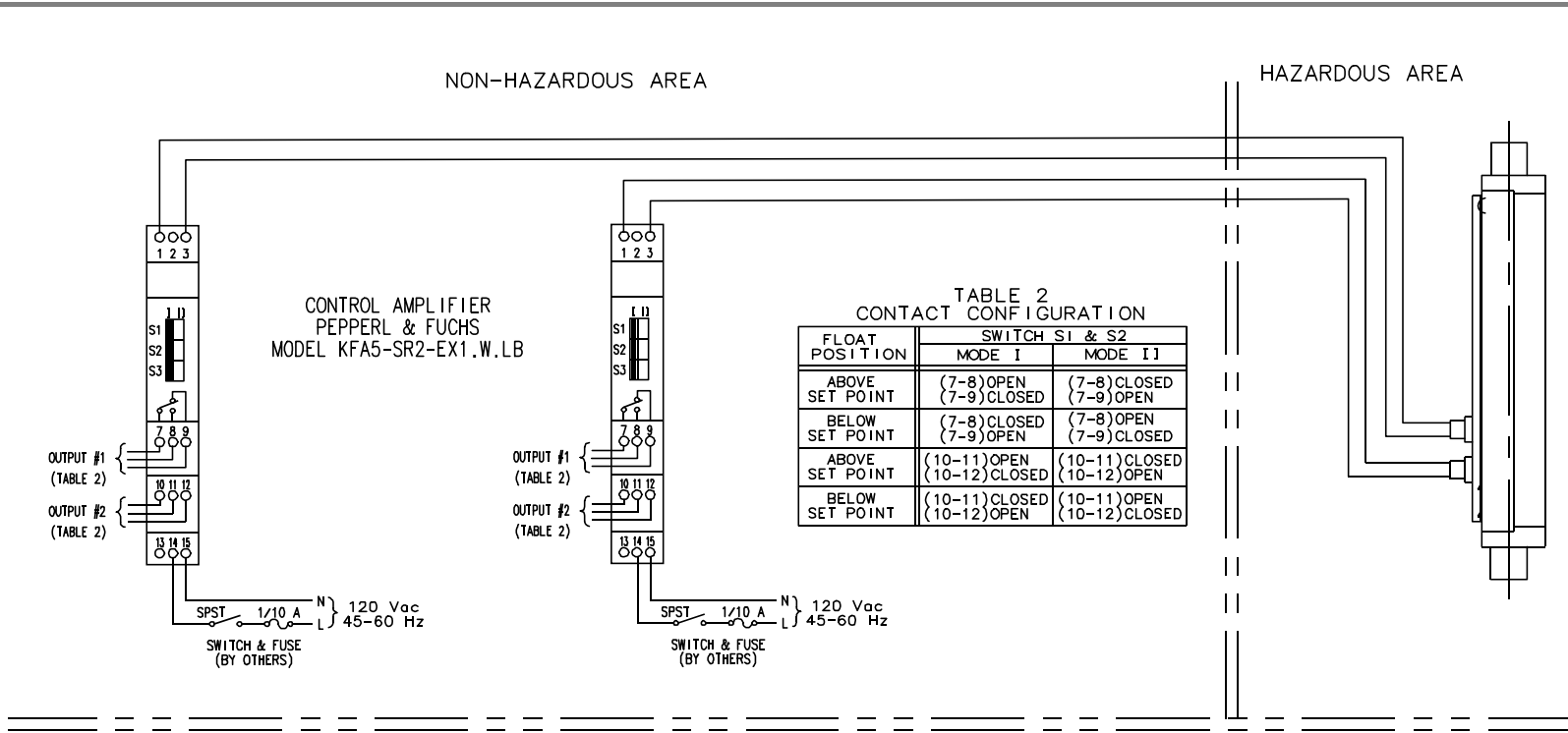

FIGURE 3-11. DUAL (HIGH/HIGH) ALARM DOUBLE POLE DOUBLE THROW RELAY OUTPUT



ELECTRICAL INSTALLATION REQUIREMENTS

NON-HAZARDOUS LOCATIONS:
WIRING SHALL COMPLY WITH THE NATIONAL ELECTRICAL CODE (ANSI/NFPA 70) AND LOCAL CODE REQUIREMENTS.

HAZARDOUS LOCATIONS:

-WARNING-
PRIOR TO INSTALLATION, THE USER SHALL DETERMINE THAT THE GLASS TUBE V/A METER IS SUITABLE FOR USE IN THE SPECIFIC HAZARDOUS LOCATION.

THE CONTROL AMPLIFIER HAS INTRINSICALLY SAFE CIRCUIT CONNECTIONS, HOWEVER THE AMPLIFIER ITSELF IS ONLY SUITABLE FOR NON-HAZARDOUS LOCATIONS. WIRING BETWEEN SENSOR SWITCHES AND THE CONTROL AMPLIFIER SHALL BE INSTALLED IN ACCORDANCE WITH ANSI/ISA RP 12.6, INSTALLATION OF INTRINSICALLY SAFE SYSTEMS FOR HAZARDOUS (CLASSIFIED) LOCATIONS.

NOTES:

1. FIELD WIRING BETWEEN SENSOR SWITCHES AND CONTROL AMPLIFIER(S) SHOULD BE TWISTED PAIR, 25 AWG OR LARGER. MAXIMUM CABLE LENGTH PER TABLE 1. THE SENSOR SWITCHES ARE PROVIDED WITH 1.5m (5 FT) OF CABLE. ALL ADDITIONAL FIELD WIRING BY OTHERS.
2. AMPLIFIER RELAY CONTACTS ARE UNPOWERED AND ARE RATED AT 2A, 250V. CONTACTS ARE SHOWN DE-ENERGIZED. CONTACTS ARE NOT TO BE PARALLELED TO INCREASE CURRENT RATING.

TABLE 1 CABLE LENGTH

TRANSMITTER LOCATION	MAXIMUM LENGTH (NOTE 1)	
NON-HAZARDOUS OR DIV 2	1mi	1.5km
CLASS I, DIV 1, GROUPS A & B	3000ft	900m
CLASS I, DIV 1, GROUP C & D CLASS II, DIV 1, GROUP E, F & G	1mi	1.5km

CABLE CAPACITANCE: LESS THAN 60 picofarad/ft (197 picofarad/m)

INDUCTANCE: LESS THAN 0.2 microhenry/ft (0.656 microhenry/m)

ID-10-1132 REV 0

FIGURE 3-12. DUAL (LOW/LOW) ALARM DOUBLE POLE DOUBLE THROW RELAY OUTPUT

NOTES

- 1) ALL DIMENSIONS ARE IN INCHES. DIMENSIONS IN PARENTHESIS [] ARE IN MILLIMETERS [mm].
- 2) DIMENSIONS ARE GUARANTEED ONLY IF THIS PRINT IS CERTIFIED.
- 3) THIS DRAWING IS A THIRD ANGLE PROJECTION AS SHOWN. 
- 4) ALL DIMENSIONS SUBJECT TO MANUFACTURING TOLERANCES OF +/-1/8 [3] .

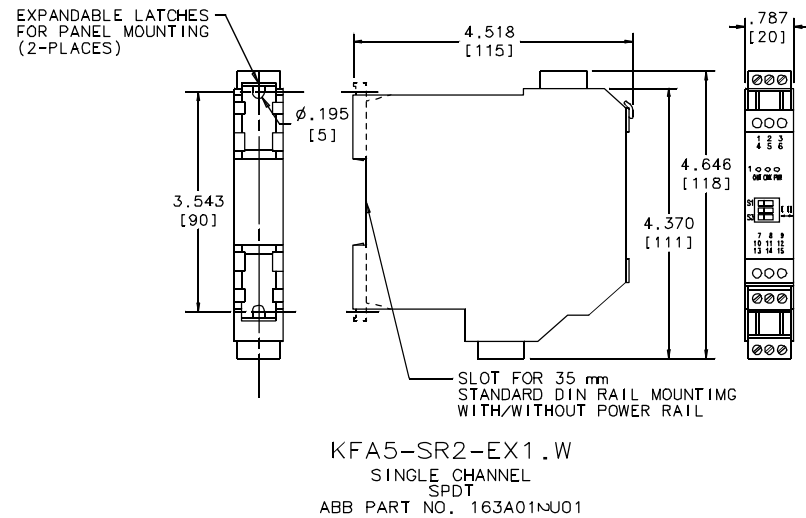
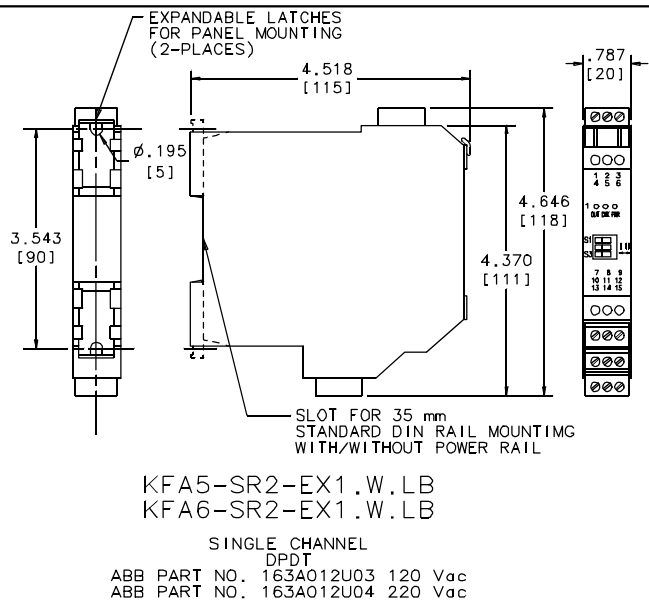
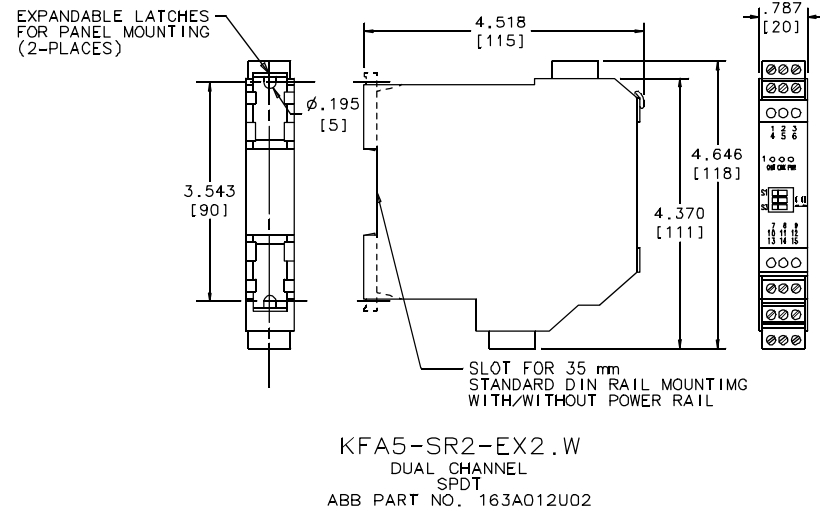

Ref. OD-10-2820

FIGURE 3-13. OUTLINE DIMENSIONS OF CONTROL AMPLIFIER

4.0 MAINTENANCE

4.1 General

WARNING

Failure to comply with the following precautions may result in operator injury. Glass tubes are not recommended for either hot or strong alkalis, fluorine, hydrofluoric acid, steam or water over 200° F (93° C). Meter tubes should be periodically inspected for signs of wear. Erosion, stress cracks or nicks provide early warning for tube replacement. With certain fluids, the glass may erode evenly so that wear is not visibly noticeable. If wear is suspected the tube must be replaced.

The only maintenance required is occasional cleaning of the tube, float and operator protection shield. The meter should be cleaned frequently enough to preserve accuracy and float visibility.

The meter tube and the float are precision manufactured parts. Never subject the meter tube to unnecessary shock or strain. When removing the tube, be careful not to drop the meter float. Handle the float with care because a nick or scratch will destroy the meter's accuracy. Read the information in the front of this bulletin regarding glass and its handling.

4.2 Cleaning Operator Protection Shield

WARNING

DO NOT OPERATE THE FLOWMETER WITHOUT THE OPERATOR PROTECTION SHIELD IN PLACE. TO DO SO MAY RESULT IN OPERATOR INJURY.

Remove the operator protection shield as described in Section 2.4.5.3. Clean the shield with a solution of soap or detergent and water. If this does not clean the shield sufficiently, use kerosene and follow up with soap or detergent and water. Rinse well with clean water and dry with a soft cloth.

CAUTION

Do not clean the protective shield with cleaners containing strong mineral acids or organic solvents such as ketones, chlorinated hydrocarbons and aromatics. Using such cleaners may impair the protective and optical qualities of the shield.

4.3 10A4500 Flowmeter Tube and Float Removal and Installation

4.3.1 10A4500 Flowmeter Tube and Float Removal (refer to Figure 5-1)

To remove the meter tube and float from a 10A4500 Flowmeter, proceed as follows:

WARNING
Remove pressure from the meter before attempting to remove the meter tube or operator protection shield.

- 1) Close the valves on either side of the meter. If the meter contains liquid, the liquid must be drained before proceeding.
- 2) Remove the operator protection shield as described in Section 2.4.5.3.
- 3) Grasp the meter tube, and rotate back and forth to break the seal between the tube and O-ring. When the tube is free, slowly but firmly push the tube upward into the spring loaded outlet end fitting until the bottom of the tube clears the inlet end fitting. When the tube is clear, move the bottom of the tube outward from the meter body and then lower the tube from the outlet end fitting.
- 4) Remove the float by inverting the tube. Meters with a 1/2 inch tube have an outlet float stop pressed into the outlet end bell of the tube that must be removed first. In all other sizes the outlet float stop is held in the outlet end fitting.
- 5) Clean the meter tube and float with a mild detergent and water, or a suitable solvent. A soft cloth or a brush may be used to clean the tube.

4.3.2 10A4500 Flowmeter Tube and Float Installation

To install a 10A4500 Flowmeter tube and float, proceed as follows:

- 1) Inspect the O-rings on the end fittings for nicks or cuts. Replace any defective O-rings. The O-rings should be coated sparingly with a silicone grease (or a lubricant that is compatible with the process fluid) to prevent damage at installation. Check to see that the tube rest gasket is in place on the inlet end fitting.
- 2) Install the inlet float stop, the float and the outlet float stop (1/2 inch tube only) into the tube. Check Figure 3-1 to see that the float is correctly oriented.
- 3) Place the end of the meter tube with the highest scale graduation against the spring loaded washer in the outlet end fitting and push the tube upward until the bottom of the tube will clear the inlet end fitting.
- 4) Move the bottom of the tube in until it is centered over the inlet end fitting, then allow the tube to move downward over the O-ring on the inlet end fitting. Rotate the tube as required to make the reference mark at the bottom of the tube face forward. Make certain that the tube is firmly seated on the inlet end fitting tube rest gasket.
- 5) **Replace the operator protection shield to complete the installation.**

4.4 10A4600 Flowmeter Tube and Float Removal and Installation

4.4.1 10A4600 Flowmeter Tube and Float Removal (refer to Figure 5-2)

To remove the meter tube and float from a 10A4600 Flowmeter, proceed as follows:

WARNING
Remove pressure from the meter before attempting to remove the meter tube or operator protection shield.

- 1) Close the valves on either side of the meter. If the meter contains liquid, the liquid must be drained before proceeding.
- 2) Remove the operator protection shield as described in 2.4.5.3.
- 3) Remove the four (4) packing gland compression screws from each end of the meter. Move the packing gland and packing axially along the ends of the meter tube away from the end fittings.
- 4) Grasp the meter tube, and slowly but firmly push the tube upward into the outlet end fitting until the bottom of the tube clears the inlet end fitting. When the tube is clear, move the bottom of the tube outward from the meter body and then lower the tube from the outlet end fitting.
- 5) Remove the meter float by inverting the tube. Meters with a 1/2 inch tube have an outlet float stop pressed into the outlet end bell of the tube that must be removed first. In all other sizes the outlet float stop is held in the outlet end fitting.
- 6) Clean the meter tube and float with a mild detergent and water, or a suitable solvent. A soft cloth or a brush may be used to clean the tube.

4.4.2 10A4600 Flowmeter Tube and Float Installation

To install a tube and float into a 10A4600 Flowmeter proceed as follows:

- 1) Remove the packing from the meter tube and inspect the tube for damage. Before replacing the tube, new packing rings should be lightly coated with silicone grease (or a lubricant that is compatible with the process fluid) to prevent the packing rings from sticking to the meter tube. Two packing rings are used on each end of the tube. When TEFLON packing is specified the standard packing is supplemented by a separate TEFLON packing liner (See Figure 5-2). When the TEFLON liner is used a metal washer is used to back-up the liner flange. Inspect the inlet fitting to see that the tube rest gasket is in place.
- 2) Install the inlet float stop, the float and the outlet float stop (1/2 inch tube only) into the tube. Check Figure 3-1 to see that the float is correctly oriented.
- 3) Place the packing glands and packing rings on the tube. Refer to Figure 5-2, for an exploded view of the packing for the 10A4600 meter.
- 4) Place the end of the meter tube with the highest scale graduation in the outlet end fitting and move the tube upward until the bottom of the tube will clear the inlet fitting.

NOTE

Be careful to center the meter tube over the center post and to maintain a minimum angle to prevent tube breakage.

5) Move the bottom of the tube in until it is centered over the inlet end fitting, then allow the tube to move downward over the center post on the inlet fitting. Manually seat the tube on the inlet fitting tube rest gasket. Rotate the tube as required to make the etched scale visible.

6) Push packing and retainers into end fittings and install packing compression screws. Tighten inlet gland screws first so that the tube does not pull up from inlet tube rest gasket, then tighten outlet gland screws. Pull up screws evenly but do not overtighten as tube breakage may result.

7) Replace the operator protection shield to complete the installation.

4.5 Disassembly

To completely disassemble the meter, disconnect the process piping and remove the meter from the panel or other support. Refer to Figure 5-1 (10A4500) or 5-2 (10A4600) for an exploded view of the meter, and proceed as follows:

1) Remove the tube and float as discussed in Sections 4.3 and 4.4.

2) Loosen and remove the two set screws that hold each end fitting to the frame. Pull the fittings from the frame.

4.6 Metal Scales

All 10A4500/4600 Flowmeter bodies will accommodate the installation of metal scales without body modification. The metal scale is used to provide percent of maximum flow or direct reading units.

To install the metal scale, refer to Figure 5-1. Loosen the top and bottom set screws. Tilt bottom of scale slightly toward you and insert top end of scale into upper slot. Slide bottom end of scale forward and drop into bottom slot. Screw the bottom set screw inward until the reference mark on the metal scale is aligned with the reference mark on the meter tube. Tighten the top set screw just tight enough to keep the scale from rattling. Repeat for the other scale if the meter is so equipped.

5.0 PARTS LIST

When ordering parts for the 10A4500/4600 Flowmeter, reference the serial number and model number of the meter.

TABLE 5-1. 10A4500 METER PARTS

KEY	PART DESCRIPTION	QTY	PART NUMBER
1	Body, Meter: 1/2" Meter Tube Size 3/4", 1" Meter Tube Size 1-1/2", 2" Meter Tube Size	1	609B308U01 609B308U02 609B308U03
2	*Shield, Operator Protection: 1/2" Meter Tube Size 3/4", 1" Meter Tube Size 1-1/2", 2" Meter Tube Size	1	351C194U01 351C194U02 351C194U03
3	Tube Backing: 1/2" Meter Tube Size 3/4", 1" Meter Tube Size 1-1/2", 2" Meter Tube Size	1	331C063U01 331C063U02 331C063U03
4	Screw, Hex Socket Set: 1/2" Meter Tube Size 3/4", 1" Meter Tube Size 1-1/2", 2" Meter Tube Size	4	396C210U02 396C210U03 396C210U04
5	End Fitting, Inlet: Brass/Bronze, 1/2" Meter Tube Size 316 SST, 1/2" Meter Tube Size Brass/Bronze, 3/4", 1" Meter Tube Size 316 SST, 3/4", 1" Meter Tube Size Brass/Bronze, 1-1/2", 2" Meter Tube Size 316 SST, 1-1/2", 2" Meter Tube Size	1	301A372U02 301A372U01 301A376U02 301A376U01 301A380U02 301A380U01
6	End Fitting, Outlet: Brass/Bronze, 1/2" Meter Tube Size 316 SST, 1/2" Meter Tube Size Brass/Bronze, 3/4", 1" Meter Tube Size 316 SST, 3/4", 1" Meter Tube Size Brass/Bronze, 1-1/2", 2" Meter Tube Size 316 SST, 1-1/2", 2" Meter Tube Size	1	301A374U02 301A374U01 301A378U02 301A378U01 301A382U02 301A382U01
7	Plug, Pipe: Brass/Bronze, 1/2" Meter Tube Size 316 SST, 1/2" Meter Tube Size Brass/Bronze, 3/4", 1" Meter Tube Size 316 SST, 3/4", 1" Meter Tube Size Brass/Bronze, 1-1/2", 2" Meter Tube Size 316 SST, 1-1/2", 2" Meter Tube Size	2	112A355U15 112A355U12 112A355U28 112A355U25 112A355U42 112A355U39
8	Flange, Threaded: Brass/Bronze, 1/2" Meter Tube Size 316 SST, 1/2" Meter Tube Size Brass/Bronze, 3/4", 1" Meter Tube Size 316 SST, 3/4", 1" Meter Tube Size Brass/Bronze, 1-1/2", 2" Meter Tube Size 316 SST, 1-1/2", 2" Meter Tube Size	2	113A255U02 113A255U01 113A255U04 113A255U03 113A255U06 113A255U05
9	Pipe Nipple, Horizontal: Brass/Bronze, 1/2" Meter Tube Size 316 SST, 1/2" Meter Tube Size Brass/Bronze, 3/4", 1" Meter Tube Size 316 SST, 3/4", 1" Meter Tube Size Brass/Bronze, 1-1/2", 2" Meter Tube Size 316 SST, 1-1/2", 2" Meter Tube Size	2	362N162B16 362N162T60 362N145B16 362N145T60 362N410B16 362N410T60

TABLE 5-1. 10A4500 METER PARTS (continued)

KEY	PART DESCRIPTION	QTY	PART NUMBER
10	Pipe Nipple, Vertical: Brass/Bronze, 1/2" Meter Tube Size 316 SST, 1/2" Meter Tube Size Brass/Bronze, 3/4", 1" Meter Tube Size 316 SST, 3/4", 1" Meter Tube Size Brass/Bronze, 1-1/2", 2" Meter Tube Size 316 SST, 1-1/2", 2" Meter Tube Size	2	362N066B16 362N066T60 362N137B16 362N137T60 362N420B16 362N420T60
11	*Gasket, Tube Rest: 1/2" Meter Tube Size 3/4", 1" Meter Tube Size 1-1/2", 2" Meter Tube Size	1	333C471Q20 333C472Q20 333C473Q20
12	**O" Ring: Buna N: 1/2" Meter Tube Size 3/4", 1" Meter Tube Size 1-1/2", 2" Meter Tube Size VITON: 1/2" Meter Tube Size 3/4", 1" Meter Tube Size 1-1/2", 2" Meter Tube Size EPR: 1/2" Meter Tube Size 3/4", 1" Meter Tube Size 1-1/2", 2" Meter Tube Size	2	101A711U01 101A921U01 101A937U01 101W711U01 101W921U01 101W937U01 101F711U01 101F921U01 101F937U01
13	Float Stop, Inlet: 1/2" Meter Tube Size 3/4", 1" Meter Tube Size 1-1/2", 2" Meter Tube Size	1	304D068U01 304D080U01 304D082U01
14	*Float, Meter - Order By ABB Automation Serial Number and Model Number.		
15	*Tube, Meter - Order By ABB Automation Serial Number and Model Number.		
16	Float Stop, Outlet: 1/2" Meter Tube Size 3/4", 1" Meter Tube Size, 1-1/2", 2" Meter Tube Size	1	304D069U01 304D072U01 304D075U01
17	Tag, Model Number, Serial Number	1	338D318U01
18	Washer, Tube Retainer: 1/2" meter Tube Size 3/4", 1" Meter Tube Size 1-1/2", 2" Meter Tube Size	1	377A204T12 377A205T12 377A206T12
19	Spring, Tube Retainer: 1/2" Meter Tube Size 3/4", 1" Meter Tube Size 1-1/2", 2" Meter Tube Size	1	424A234V91 424A235V91 424A236V91
20	Scales, Metal - Order By ABB Automation Serial Number and Model Number.		
21	Metal Scale Set Screw: 1/2" Meter Tube Size 3/4", 1" Meter Tube Size 1-1/2", 2" Meter Tube Size	As Req'd	048A010T10 048C012T10 048E014T10

* Indicates Recommended Spare Part

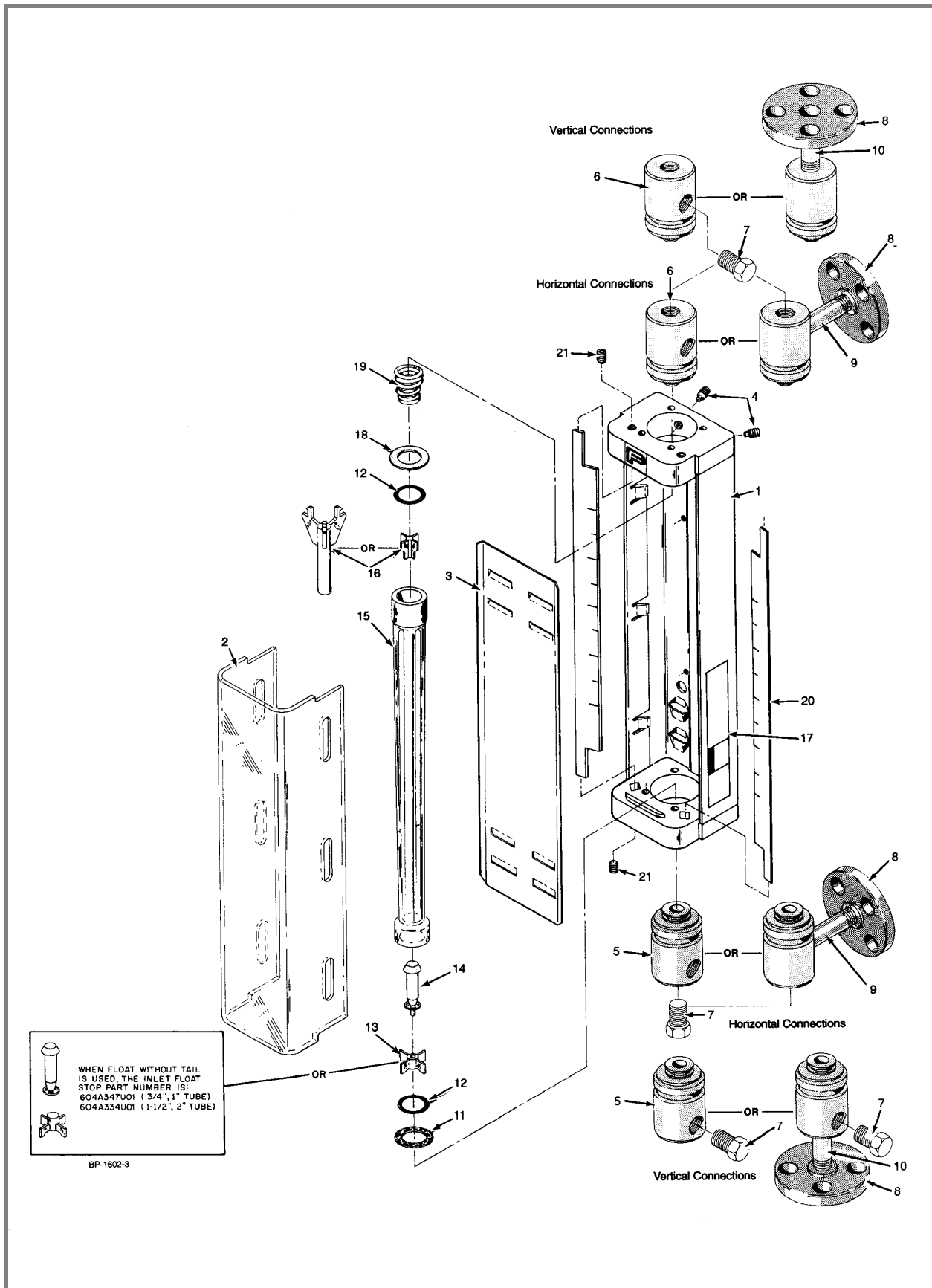

FIGURE 5-1. 10A4500 METER ASSEMBLY

TABLE 5-2. 10A4600 METER PARTS

KEY	PART DESCRIPTION	QTY	PART NUMBER
1	Body, Meter: 1/2" Meter Tube Size 3/4", 1" Meter Tube Size 1-1/2", 2" Meter Tube Size	1	609B308U01 609B308U02 609B308U03
2	*Shield, Operator Protection: 1/2" Meter Tube Size 3/4", 1" Meter Tube Size 1-1/2", 2" Meter Tube Size	1	351C194U01 351C194U02 351C194U03
3	Tube Backing: 1/2" Meter Tube Size 3/4", 1" Meter Tube Size 1-1/2", 2" Meter Tube Size	1	331C063U01 331C063U02 331C063U03
4	Screw, Hex Socket Set: 1/2" Meter Tube Size 3/4", 1" Meter Tube Size 1-1/2", 2" Meter Tube Size	4	396C210U02 396C210U03 396C210U04
5	End Fitting, Inlet: Brass/Bronze, 1/2" Meter Tube Size 316 SST, 1/2" Meter Tube Size Brass/Bronze, 3/4", 1" Meter Tube Size 316 SST, 3/4", 1" Meter Tube Size Brass/Bronze, 1-1/2", 2" Meter Tube Size 316 SST, 1-1/2", 2" Meter Tube Size	1	301A372U02 301A372U01 301A376U02 301A376U01 301A380U02 301A380U01
6	End Fitting, Outlet: Brass/Bronze, 1/2" Meter Tube Size 316 SST, 1/2" Meter Tube Size Brass/Bronze, 3/4", 1" Meter Tube Size 316 SST, 3/4", 1" Meter Tube Size Brass/Bronze, 1-1/2", 2" Meter Tube Size 316 SST, 1-1/2", 2" Meter Tube Size	1	301A374U02 301A374U01 301A378U02 301A378U01 301A382U02 301A382U01
7	Plug, Pipe: Brass/Bronze, 1/2" Meter Tube Size 316 SST, 1/2" Meter Tube Size Brass/Bronze, 3/4", 1" Meter Tube Size 316 SST, 3/4", 1" Meter Tube Size Brass/Bronze, 1-1/2", 2" Meter Tube Size 316 SST, 1-1/2", 2" Meter Tube Size	2	112A355U15 112A355U12 112A355U28 112A355U25 112A355U42 112A355U39
8	Flange, Threaded: Brass/Bronze, 1/2" Meter Tube Size 316 SST, 1/2" Meter Tube Size Brass/Bronze, 3/4", 1" Meter Tube Size 316 SST, 3/4", 1" Meter Tube Size Brass/Bronze, 1-1/2", 2" Meter Tube Size 316 SST, 1-1/2", 2" Meter Tube Size	2	113A255U02 113A255U01 113A255U04 113A255U03 113A255U06 113A255U05
9	Pipe Nipple, Horizontal: Brass/Bronze, 1/2" Meter Tube Size 316 SST, 1/2" Meter Tube Size Brass/Bronze, 3/4", 1" Meter Tube Size 316 SST, 3/4", 1" Meter Tube Size Brass/Bronze, 1-1/2", 2" Meter Tube Size 316 SST, 1-1/2", 2" Meter Tube Size	2	362N162B16 362N162T60 362N145B16 362N145T60 362N410B16 362N410T60
continued			

TABLE 5-2. 10A4600 METER PARTS (continued)

KEY	PART DESCRIPTION	QTY	PART NUMBER
10	Pipe Nipple, Vertical: Brass/Bronze, 1/2" Meter Tube Size 316 SST, 1/2" Meter Tube Size Brass/Bronze, 3/4", 1" Meter Tube Size 316 SST, 3/4", 1" Meter Tube Size Brass/Bronze, 1-1/2", 2" Meter Tube Size 316 SST, 1-1/2", 2" Meter Tube Size	2	362N066B16 362N066T60 362N137B16 362N137T60 362N420B16 362N420T60
11	Screw, Hex Socket: 1/2" Meter Tube Size 3/4", 1" Meter Tube Size 1-1/2", 2" Meter Tube Size	8	008H128T10 008M148T10 038B178T10
12	*Gasket, Tube Rest (not required on PVC fittings): KLINGER SIL C4401: 1/2" Meter Tube Size 3/4", 1" Meter Tube Size 1-1/2", 2" Meter Tube Size TEFLON: 1/2" Meter Tube Size 3/4", 1" Meter Tube Size 1-1/2", 2" Meter Tube Size	1	333C471Q20 333C472Q20 333C473Q20 333C471P30 333C472P30 333C473P30
13	*Packing, With TEFLON Liner: 1/2" Meter Tube Size 3/4", 1" Meter Tube Size 1-1/2", 2" Meter Tube Size	2	605P174U01 605P176U01 605P178U01
14	Liner, Packing: 1/2" Meter Tube Size 3/4", 1" Meter Tube Size 1-1/2", 2" Meter Tube Size	2	334B004P30 334B005P30 334B006P30
15	Washer: 1/2" Meter Tube Size 3/4", 1" Meter Tube Size 1-1/2", 2" Meter Tube Size	2	377A254T12 377A255T12 377A256T12
16	Ring: 1/2" Meter Tube Size 3/4", 1" Meter Tube Size 1-1/2", 2" Meter Tube Size	4	334C172Q10 334C173Q10 334C174Q10
17	*Packing Without Liner: 1/2" Meter Tube Size 3/4", 1" Meter Tube Size 1-1/2", 2" Meter Tube Size	1	605P175U01 605P177U01 605P179U01
18	Ring, Packing: 1/2" Meter Tube Size 3/4", 1" Meter Tube Size 1-1/2", 2" Meter Tube Size	4	334C219Q10 334C220Q10 334C221Q10
19	Washer: 1/2" Meter Tube Size 3/4", 1" Meter Tube Size 1-1/2", 2" Meter Tube Size	2	377A254T12 377A255T12 377A256T12
continued			

TABLE 5-2. 10A4600 METER PARTS (continued)

KEY	PART DESCRIPTION	QTY	PART NUMBER
20	Float Stop, Inlet: 1/2" Meter Tube Size 3/4", 1" Meter Tube Size 1-1/2", 2" Meter Tube Size	1	304D068U01 304D080U01 304D082U01
21	*Float, Meter - Order By ABB Automation Serial Number and Model Number.		
22	*Tube, Meter - Order By ABB Automation Serial Number and Model Number.		
23	Float Stop, Outlet: 1/2" Meter Tube Size 3/4", 1" Meter Tube Size, 1-1/2", 2" Meter Tube Size	1	304D069U01 304D072U01 304D075U01
24	Gland, Packing: 1/2" Meter Tube Size 3/4", 1" Meter Tube Size, 1-1/2", 2" Meter Tube Size	1	307C104U01 307C104U02 307C104U03
25	Tag, Model Number , Serial Number	1	338D318U01
26	Metal Scale Set Screw: 1/2" Meter Tube Size 3/4", 1" Meter Tube Size 1-1/2", 2" Meter Tube Size	As Req'd	048A010T10 048C012T10 048E014T10
27	Scales, Metal - Order By ABB Automation Serial Number and Model Number.		

* Indicates Recommended Spare Part

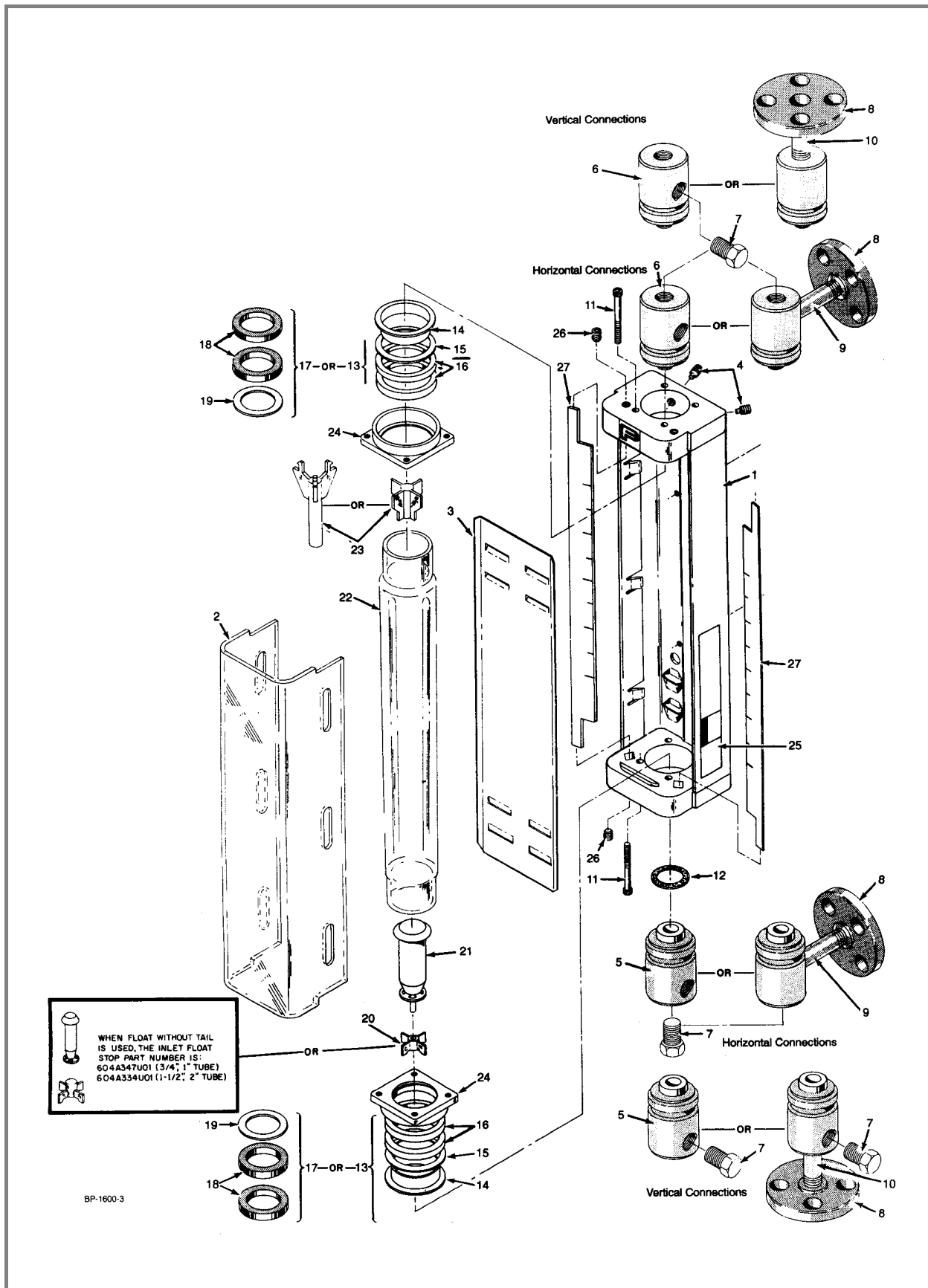
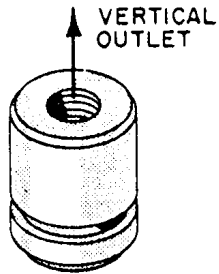

FIGURE 5-2. 10A4600 METER ASSEMBLY

PVC
THREADED CONNECTION
END FITTINGS



METER SIZE	PVC PART NUMBER
1/2 X 1/2	601B123U02
3/4 X 3/4	601B123U04
3/4 X 1	601B123U04
1-1/2 X 1-1/2	601B123U06
1-1/2 X 2	601B123U06

PVC
FLANGED CONNECTION
END FITTINGS

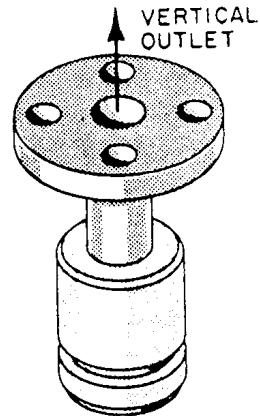

METER SIZE	PVC PART NUMBER
1/2 X 1/2	601B124U02
1 X 3/4	601B124U04
1 X 1	601B124U04
1-1/2 X 1-1/2	601B124U06
1-1/2 X 2	601B124U06

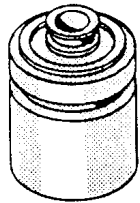

↑
VERTICAL
INLET

METER SIZE	PVC PART NUMBER
1/2 X 1/2	601B123U01
3/4 X 3/4	601B123U03
3/4 X 1	601B123U03
1-1/2 X 1-1/2	601B123U05
1-1/2 X 2	601B123U05

GP-1296

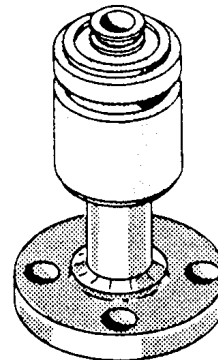

↑
VERTICAL
INLET

METER SIZE	PVC PART NUMBER
1/2 X 1/2	601B124U01
1 X 3/4	601B124U03
1 X 1	601B124U03
1-1/2 X 1-1/2	601B124U05
1-1/2 X 2	601B124U05

FIGURE 5-3. PVC END FITTINGS

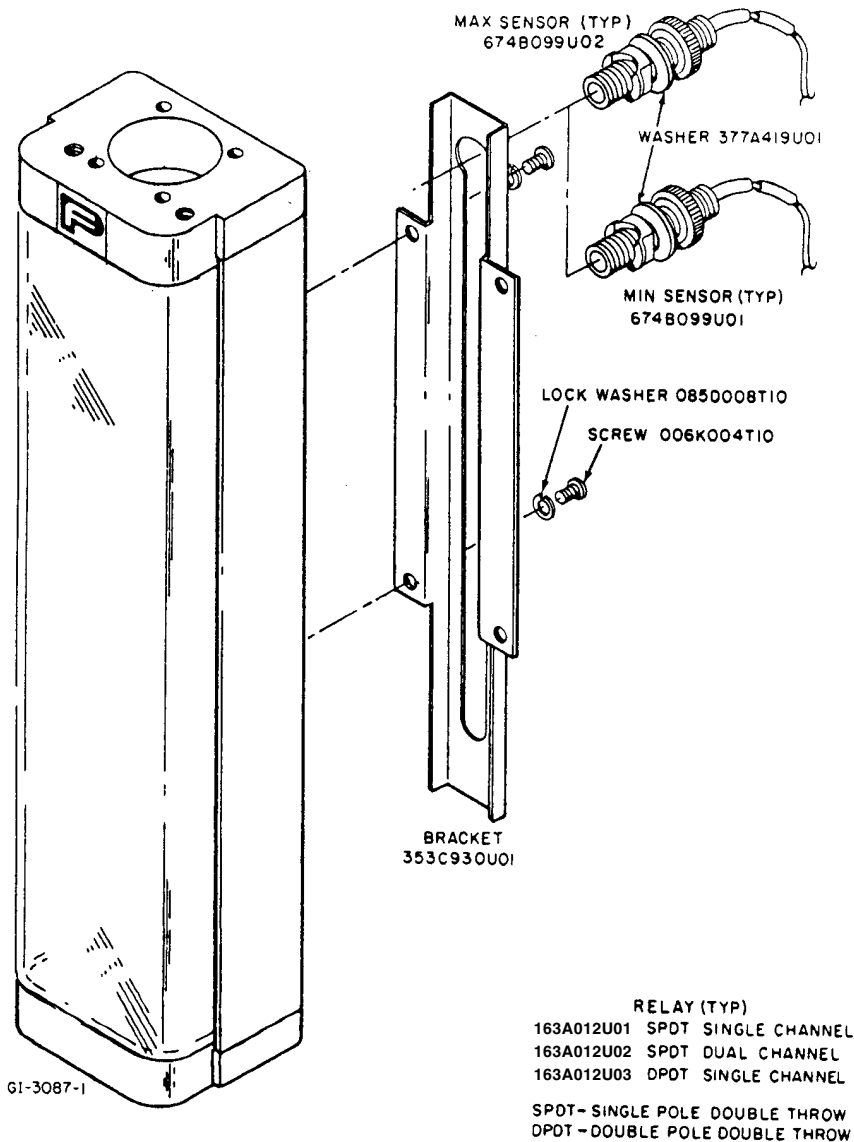

Relay Output	SPDT					DPDT				
	M A X	M I N	M A X / M I N	M A X / M I N	M I N	M A X	M I N	M A X / M I N	M A X / M I N	M I N
674B099U02 Sensor, Max	1		1	2		1		1	2	
674B099U01 Sensor, Min		1	1		2		1	1		2
163A012U01 Relay	1	1								
163A012U02 Relay			1	1	1					
163A012U03 Relay						1	1	2	2	2

FIGURE 5-4. ALARM ASSEMBLY

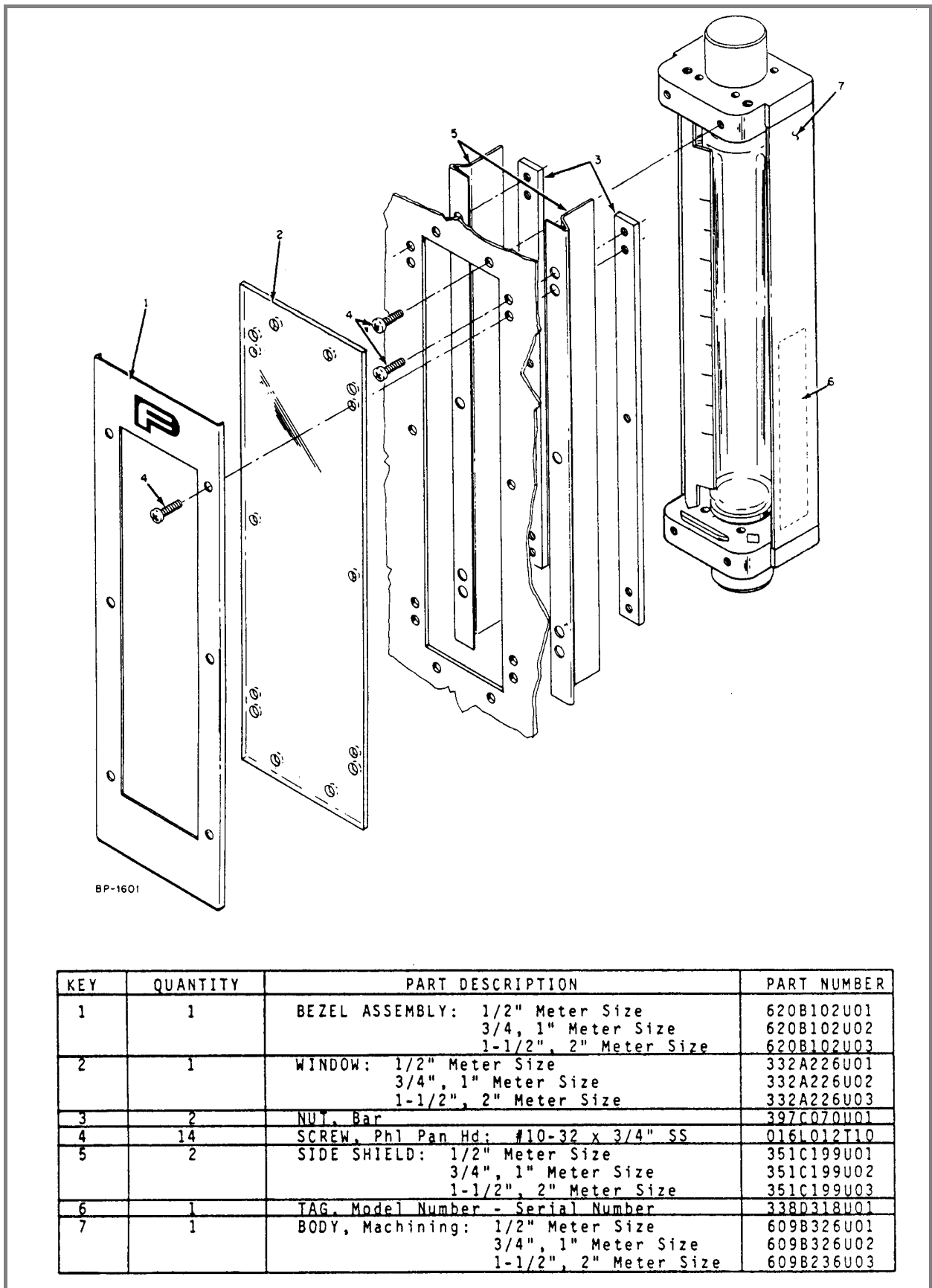

FIGURE 5-5. REAR PANEL MOUNTING

PN24987



The Company's policy is one of continuous product improvement and the right is reserved to modify the information contained herein without notice.
© 2001 ABB Automation Inc. Printed in USA

ABB Automation Inc.
125 East County Line Road
Warminster, PA 18974 USA
Tel. 215-674-6000
FAX: 215-674-7183

ABB Instrumentation Ltd
Howard Road, St. Neots
Cams. England, PE19 3EU
Tel. +44 (0) 1480-475-321
FAX: +44 (0) 1480-217-948

ABB Instrumentation S.p.A
Via Sempione 243
20016 Pero (Milano) Italy
Tel: +39 (02) 33928 1
Fax: +39 (02) 33928 240

ABB Automation Products GmbH
Industriestr. 28
D-65760 Eschborn Germany
Tel: +49 (0) 6196 800 0
Fax: +49 (0) 6196 800 1849