

Type TB82PH Advantage Series™ 2-wire pH/ORP/pION transmitter



CONTENTS

Section	Page
CONTENTS.....	2
USE OF INSTRUCTIONS	2
INTRODUCTION.....	3
PRODUCT IDENTIFICATION	3
EUROPEAN ATEX DIRECTIVE INFORMATION.....	4
TRANSMITTER MOUNTING DETAILS.....	12
ELECTRICAL CONNECTIONS - Power Wiring	13
SENSOR CONNECTIONS – Model TB5 & TBX5	
Sensor Connections	14
OPERATING PROCEDURES	16
Commissioning the Instrument	16
Flow Chart For Basic Operation Mode.....	17
CONFIGURE MODE	18
Flow Chart For Advanced Mode	20
CALIBRATE MODE.....	21
OUTPUT/HOLD MODE.....	21
SECURITY MODE	22
SECONDARY DISPLAY MODE.....	22
MAINTENANCE	22
DISMANTLING AND RE-ASSEMBLY	23
SPECIFICATIONS	24

USE OF INSTRUCTIONS



Warning.

An instruction that draws attention to the risk of injury or death.



Caution.

An instruction that draws attention to the risk of damage to the product, process or surroundings.



Note.

Clarification of an instruction or additional information.



Information.

Further reference for more detailed information or technical details.

Although **Warning** hazards are related to personal injury, and **Caution** hazards are associated with equipment or property damage, it must be understood that operation of damaged equipment could, under certain operational conditions, result in degraded process system performance leading to personal injury or death. Therefore, comply fully with all **Warning** and **Caution** notices.

Information in this manual is intended only to assist our customers in the efficient operation of our equipment. Use of this manual for any other purpose is specifically prohibited and its contents are not to be reproduced in full or part without prior approval of Technical Communications Department, ABB Inc.

Health and Safety

To ensure that our products are safe and without risk to health, the following points must be noted:

1. The relevant sections of these instructions must be read carefully before proceeding.
2. Warning labels on containers and packages must be observed.
3. Installation, operation, maintenance and servicing must only be carried out by suitably trained personnel and in accordance with the information given.
4. Normal safety precautions must be taken to avoid the possibility of an accident occurring when operating in conditions of high pressure and/or temperature.
5. Chemicals must be stored away from heat, protected from temperature extremes and powders kept dry. Normal safe handling procedures must be used.
6. When disposing of chemicals ensure that no two chemicals are mixed.

Safety advice concerning the use of the equipment described in this manual or any relevant hazard data sheets (where applicable) may be obtained from the Company address on the back cover, together with servicing and spares information.

INTRODUCTION

This manual describes the installation, safe usage, commissioning, adjustment, and maintenance procedures related to the Analog versions of the TB82PH and ML82PH pH/ORP/pION Product Family.

PRODUCT IDENTIFICATION

The data plates shown in **Figure 1** identify the instrument. The Nameplate (Reference A) provides information concerning the product identity code (i.e., nomenclature), product name, operating voltage range, output type, serial number, test personnel badge number, and dielectric strength verification stamp.

The Agency Approval label (Reference B) is included when the transmitter is purchased for compliance with hazardous area regulations (e.g., intrinsic safety protection) for a specific country (e.g., CSA, FM, or ATEX).

EC conformance is identified using a CE label (Reference C). Optional tagging, as specified by customer requirements, is provided via an additional tag. (Reference D)

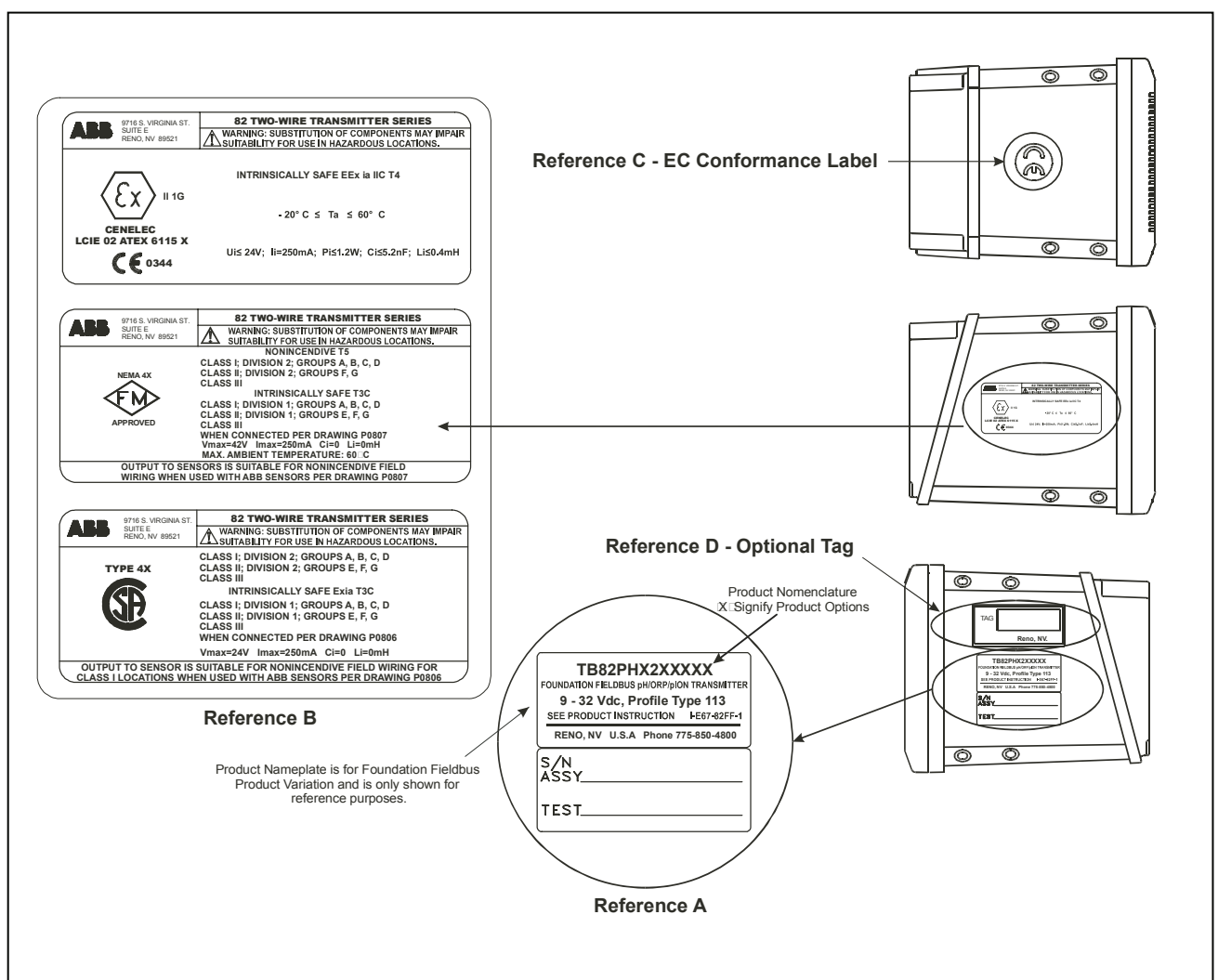

Figure 1 – Product Identification
Labels are shown for information only
Refer to ATEX Certificate for electrical parameters





EUROPEAN ATEX DIRECTIVE INFORMATION

Special conditions for safe use

The TB82/ML82 product variations can be installed in explosive atmospheres designated by the product labeling. These product variations must only be combined with an associated, certified intrinsically safe apparatus. This combination must be compatible as far as intrinsic safety is concerned (See section A6 of the following ATEX certificate). Temperature Class T4 corresponds to an ambient temperature range from -20°C to $+60^{\circ}\text{C}$.

Deutsch

- 1 EG-TYPENPRÜFUNGSZERTIFIKAT
- 2 Gerät oder Schutzsystem für den Einsatz in potenziellen Ex-Bereichen
Richtlinie 94/9/EG
- 3 Nummer des EG-Typenprüfungszertifikats: **LCIE 02 ATEX 6115 X**
- 4 Gerät oder Schutzsystem: pH- oder Leitfähigkeits-Messumformer,
Typ: TB82.../ML82...
- 5 Antragsteller:
- 6 Adresse:
- 7 Dieses Gerät oder Schutzsystem und alle akzeptablen Varianten werden in der Anlage dieses Zertifikats und in den dort genannten Dokumenten angegeben.
- 8 LCIE, Benannte Stelle Nr. 0081 gemäß Artikel 9 der Richtlinie 94/9/EG des Europäischen Parlaments und Rats vom 23. März 1994, bestätigt hiermit, dass dieses Gerät oder Schutzsystem die grundlegenden Gesundheits- und Sicherheitsanforderungen an die Konstruktion und den Aufbau des Geräts oder Schutzsystems erfüllt, das für den Einsatz in potenziellen Ex-Bereichen nach Anhang II dieser Richtlinie vorgesehen ist. Die Prüfung und die Testergebnisse sind im vertraulichen Bericht Nr. 41 023 010 festgehalten.
- 9 Die Erfüllung der grundlegenden Gesundheits- und Sicherheitsanforderungen wurde gemäß der folgenden Richtlinien festgestellt: - EN 50014 (1997) + Anhang 1 und 2, - EN 50020 (1994)
- 10 Wenn die Zertifikatsnummer auf den Buchstaben „X“ endet, bedeutet dies, dass das Gerät oder Schutzsystem den besonderen Bedingungen für den sicheren Einsatz gemäß der Anlage dieses Zertifikats unterliegt.
- 11 Dieses EG-Typenprüfungszertifikat erstreckt sich ausschließlich auf die Konstruktionsprüfung und die Prüfung des genannten Geräts oder Schutzsystems gemäß Richtlinie 94/9/EG.
Das Fertigungsverfahren und die Lieferung dieses Geräts oder Schutzsystems unterliegen weiteren Anforderungen der Richtlinie, die durch dieses Zertifikat nicht abgedeckt werden.
- 12 Die Kennzeichnung des Geräts oder Schutzsystems muss Folgendes enthalten: **Ex II 1 G, EEx ia IIC T4**

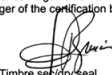
 	
<ol style="list-style-type: none"> 1 ATTESTATION D'EXAMEN CE DE TYPE 2 Appareils et systèmes de protection destinés à être utilisés en atmosphères explosibles Directive 94/9/CE 3 Numéro de l'attestation CE de type LCIE 02 ATEX 6115 X 4 Appareil ou système de protection Transmetteur de pH ou de conductivité Type : TB82.../ML82... 5 Demandeur : ABB Inc. 6 Adresse : 2175 Lockheed way Carson City Nevada 89706 - USA 7 Cet appareil ou système de protection et ses variantes éventuelles acceptées est décrit dans l'annexe de la présente attestation et dans les documents descriptifs cités en annexe. 8 La LCIE, organisme notifié sous la référence 0081 conformément à l'article 9 de la directive 94/9/CE du Parlement européen et du Conseil du 23 mars 1994, certifie que cet appareil ou système de protection est conforme aux exigences essentielles en ce qui concerne la sécurité et la santé pour la conception et la construction d'appareils et de systèmes de protection destinés à être utilisés en atmosphères explosibles, données dans l'annexe II de la directive. Les vérifications et épreuves figurent dans notre rapport confidentiel N° 41 023 010. 9 Le respect des exigences essentielles en ce qui concerne la sécurité et la santé est assuré par la conformité aux documents suivants : - EN 50014 (1997) + amendements 1 et 2 - EN 50020 (1994) 10 Le signe X lorsqu'il est placé à la suite du numéro de l'attestation, indique que ce matériel ou système de protection est soumis aux conditions spéciales pour une utilisation sûre, mentionnées dans l'annexe de la présente attestation. 11 La présente attestation d'examen CE de type porte uniquement sur la conception, l'examen et l'essai de l'équipement ou du système de protection spécifié conformément à la directive 94/9/CE. Toutes autres exigences de la Directive sont applicables au procédé de fabrication et de livraison de cet équipement ou système de protection. Ces derniers ne sont pas couverts par la présente attestation. 12 Le marquage de l'appareil ou du système de protection devra comporter, entre autres indications utiles, les mentions suivantes :  EEx ia IIC T4 	<ol style="list-style-type: none"> 1 EC TYPE EXAMINATION CERTIFICATE 2 Equipment or Protective System intended for use in Potentially explosive atmospheres Directive 94/9/EC 3 EC Type Examination Certificate number LCIE 02 ATEX 6115 X 4 Equipment or Protective system pH or conductivity transmitter Type : TB82.../ML82... 5 Applicant : ABB Inc. 6 Address : 2175 Lockheed way Carson City Nevada 89706 - USA 7 This equipment or protective system and any acceptable variation thereto is specified in the schedule to this certificate and the documents therein referred to. 8 LCIE, notified body number 0081 in accordance with article 9 of the directive 94/9/EC of the European Parliament and Council of 23 March 1994, certifies that this equipment or protective system has been found to comply with the Essential Health and Safety Requirements relating to the design and construction of equipment and protective system intended for use in potentially explosive atmospheres, given in Annex II to the directive. The examination and test results are recorded in confidential report No 41 023 010. 9 Compliance with the Essential Health and Safety Requirements has been assured by compliance with : - EN 50014 (1997) + amendments 1 and 2 - EN 50020 (1994) 10 If the sign X is placed after the certificate number, it indicates that the equipment or protective system is subject to special conditions for safe use specified in the schedule to this certificate. 11 This EC Type examination certificate relates only to the design, examination and tests of the specified equipment or protective system in accordance to the directive 94/9/EC. Further requirements of the Directive apply to the manufacturing process and supply of this equipment or protective system. These are not covered by this certificate. 12 The marking of the equipment or protective system shall include the following :  EEx ia IIC T4
<p>Fontenay-aux-Roses, le 11 septembre 2002</p> <p>Le Directeur de l'organisme certificateur Manager of the certification body</p> <p style="text-align: right;">Par délégitation Michel BRÉNON Directeur adjoint à la Certification</p> <p style="text-align: center;"> Timbre sélectif seal</p> <p style="text-align: right;">page 1/3</p> <p style="font-size: small;">Seul le texte en français peut engager la responsabilité de LCIE. Ce document ne peut être reproduit que dans son intégralité, sans aucune modification. The LCIE's liability applies only on the French text. This document may only be reproduced in full and without any change.</p> <p style="text-align: center;"> LABORATOIRE CENTRAL DES INDUSTRIES ELECTRIQUES <small>Société anonyme à Directoire et Conseil de surveillance au capital de 15 745 984 euros - RCS Nanterre B 408 363 174 33, avenue du Général Leclerc - BP n° 8 - F 92266 FONTENAY-AUX-ROSES CEDEX - Tél. : +33 1 40 95 60 60</small> </p>	

Español

- 1 CERTIFICADO DE EXAMEN DE TIPO CE
- 2 Equipo o sistema de protección para uso en atmósferas potencialmente explosivas: **Directiva 94/9/EC**
- 3 Número de certificado de examen de tipo CE: **LCIE 02 ATEX 6115 X**
- 4 Equipo o sistema de protección
transmisor de pH o de conductividad: Tipo: TB82.../ML82...
- 5 Solicitante:
- 6 Dirección:
- 7 Este equipo o sistema de protección y cualquier variación aceptable del mismo se especifica en el anexo al presente certificado y en los documentos a los que se hace referencia en el mismo.
- 8 El LCIE, organismo notificado número 0081, de acuerdo con el artículo 9 de la Directiva 94/9/EC del Parlamento Europeo y el Consejo del 23 de marzo de 1994, certifica que este equipo o sistema de protección cumple con los Requisitos Esenciales de Salud y Seguridad relacionados con el diseño y la fabricación de equipos y sistemas de protección para uso en atmósferas potencialmente explosivas, en virtud del Anexo II de la Directiva. El examen y los resultados de las pruebas han sido registrados en el informe confidencial No. 41 023 010.
- 9 El cumplimiento con los Requisitos Esenciales de Salud y Seguridad se ha asegurado con el cumplimiento de las normas: -EN 50014 (1997) + enmiendas 1 y 2, -EN 50020 (1994)
- 10 Si el signo X aparece después del número de certificado, indica que el equipo o sistema de protección se encuentra sujeto a condiciones especiales para su uso seguro especificado en el anexo al presente certificado.
- 11 El presente certificado de examen de tipo CE se refiere únicamente al examen de diseño y a las pruebas del equipo o sistema de protección especificado de acuerdo con la Directiva 94/9/EC.
Otros requisitos de la Directiva se aplican al proceso de fabricación y suministro de este equipo o sistema de protección. El presente certificado no cubre dichos requisitos.
- 12 Las marcas identificatorias del equipo o sistema de protección deben incluir lo siguiente: **Ex II 1 G, EEx ia IIC T4**

Deutsch

- (A1) ANLAGE
- (A2) EG-TYPENPRÜFUNGSZERTIFIKAT
LCIE 02 ATEX 6115 X
- (A3) Beschreibung des Geräts oder Schutzsystems

Die Messumformer TB82... oder ML82... liefern ein Ausgangssignal von 4 bis 20 mA als Reaktion auf die Ausgabe des angeschlossenen pH-Sensors (xx82PH) oder des Leitfähigkeitssensors mit vier Elektroden (xx82EC) oder des Leitfähigkeitssensors mit zwei Elektroden (xx82TE) oder des Toroidal-Leitfähigkeitssensors (xx82TC). Das HART-Datenübertragungsprotokoll kann dem 2-Leiter-Regelkreis überlagert werden. Die Modelle ML82 sind elektronisch mit den Modellen TB82 identisch; der Unterschied liegt in der Software. Die Modellausführungen werden in der Beschreibung näher erläutert.

Die Kennzeichnung lautet wie folgt:
 ABB Inc.
 Adresse: ...
 Typ: TB82.../ML82...
 Seriennummer
 Herstellungsjahr
 Ex II 1 G
 EEx ia IIC T4
 LCIE 02 ATEX 6115 X

Das CE-Zeichen muss mit der ID-Nummer der benannten Stelle versehen sein, die für die Überwachung des Qualitätssystems zuständig ist (0081 für LCIE).

Das Gerät muss außerdem mit den üblichen Kennzeichnungen gemäß den einschlägigen Fertigungsstandards für solche Geräte versehen sein.

(A4) Dokumente mit Beschreibungen:

Technische Datei Nr. A27-TB82ATEX-ER02-002A.
 Diese Datei umfasst 43 Punkte (97 Seiten).

Español

- (A1) ANEXO
- (A2) CERTIFICADO DE EXAMEN DE TIPO CE
LCIE 02 ATEX 6115 X
- (A3) Descripción del equipo o sistema de protección

Los transmisores TB82... o ML82... proporcionan una señal de salida de 4-20 mA como respuesta a la salida del sensor de pH conectado (xx82PH) o del sensor de conductividad de cuatro electrodos (xx82EC) o del sensor de conductividad de dos electrodos (xx82TE) o del sensor de conductividad toroidal (xx82TC). Pueden configurarse para el protocolo de comunicación HART superpuesto sobre el lazo de 2 hilos. Los modelos ML82 son electrónicamente idénticos a los modelos TB82, la única diferencia radica en el software. Remítase a las notas descriptivas para verificar el significado de modelo.

Las marcas identificatorias son las siguientes:
 ABB Inc.
 Dirección: ...
 Tipo: TB82.../ML82...
 Número de serie
 Año de fabricación
 Ex II 1 G
 EEx ia IIC T4
 LCIE 02 ATEX 6115 X

La marca identificatoria CE estará acompañada por el número de identificación del organismo notificado responsable de la supervisión del sistema de calidad (0081 para el LCIE).

El equipo también debe presentar las marcas identificatorias convencionales requeridas por las normas de fabricación que se aplican a dichos equipos.

(A4) Documentos descriptivos:

Archivo técnico n° A27-TB82ATEX-ER02-002A.
 Este archivo comprende 43 elementos (97 páginas).



<p>(A1) ANNEXE</p> <p>(A2) ATTESTATION D'EXAMEN CE DE TYPE LCIE 02 ATEX 6115 X</p> <p>(A3) Description de l'équipement ou du système de protection</p> <p>Les transmetteurs TB82... ou ML82... fournissent un signal 4-20 mA en réponse à un signal de sortie du capteur de pH (xx82PH) ou du capteur de conductivité à quatre électrodes (xx82EC) ou deux électrodes (xx82TE) ou du capteur toroïdale de conductivité (xx82TC) qui leur est relié. Ils peuvent être configurés pour une communication HART superposée à la boucle 2 fils. L'électronique des modèles ML82 est la même que celle des modèles TB82, la différence étant dans la programmation. Voir la notice descriptive pour la signification du modèle.</p> <p>Le marquage est le suivant : ABB Inc. Adresse : ... Type : TB82.../ML82... N° de fabrication Année de fabrication Ex II 1 G EEx ia IIC T4 LCIE 02 ATEX 6115 X</p> <p>Le marquage CE est accompagné du numéro d'identification de l'organisme notifié responsable de la surveillance du système de qualité (0081 pour le LCIE).</p> <p>Le matériel devra également comporter le marquage normalement prévu par les normes de construction du matériel électrique concerné.</p> <p>(A4) Documents descriptifs</p> <p>Dossier technique N° A27-TB82ATEX-ER02-002A. Ce document comprend 43 rubriques (97 pages).</p>	<p>(A1) SCHEDULE</p> <p>(A2) EC TYPE EXAMINATION CERTIFICATE LCIE 02 ATEX 6115 X</p> <p>(A3) Description of Equipment or protective system</p> <p>Transmitters TB82... or ML82... provide 4-20 mA output signal in response to the output of the connected pH sensor (xx82PH) or the four electrodes conductivity sensor (xx82EC) or the two-electrode conductivity sensor (xx82TE) or the toroidal conductivity sensor (xx82TC). They can be configured for HART communication protocol superimposed on the 2-wire loop. ML82 models are electronically the same as models TB82, the difference being in the software. Refer to Descriptive Notices for meaning of model.</p> <p>The marking is the following : ABB Inc. Address : ... Type : TB82.../ML82... Serial number Year of construction Ex II 1 G EEx ia IIC T4 LCIE 02 ATEX 6115 X</p> <p>The CE marking shall be accompanied by the identification number of the notified body responsible for surveillance of the quality system (0081 for the LCIE).</p> <p>The equipment must also carry the usual marking required by the manufacturing standards applying to such equipments.</p> <p>(A4) Descriptive documents :</p> <p>Technical file n° A27-TB82ATEX-ER02-002A. This file includes 43 items (97 pages).</p>
--	---

Deutsch

- (A1) ANLAGE
 (A2) EG-TYPENPRÜFUNGSZERTIFIKAT
 LCIE 02 ATEX 6115 X (Fortsetzung)
 (A5) Besondere Bedingungen für den sicheren Einsatz

Das oben definierte eigensichere Gerät kann in Ex-Bereichen aufgestellt werden.

Eine Kombination des Geräts ist ausschließlich mit einem zugehörigen, ebenfalls eigensicheren, zertifizierten Gerät zulässig. Diese Kombination muss zudem im Hinblick auf die Eigensicherheit kompatibel sein (siehe (A6)).

Die Temperaturklasse T4 bezeichnet einen Umgebungstemperaturbereich von -20 °C bis +60 °C.

Die nachstehenden Sensoren sind für den Anschluss an den Klemmenblock TB2 vorgesehen.

TB82PH/ML82PH

Kombinierte pH-Sensoren der Advantage-Serie:
 Kombinierte pH-Sensoren mit Festkörperreferenz:
 Externe Thermokompensator-Sensoren:

TB82EC/ML82EC

Leitfähigkeitssensoren mit vier Elektroden:

TB82TE/ML82TE

Leitfähigkeitssensoren mit zwei Elektroden:

TB82TC/ML82TC

Toroidal-Leitfähigkeitssensor:

- (A6) Grundlegende Gesundheits- und Sicherheitsanforderungen

Die Konstruktion des Geräts entspricht den europäischen Normen EN 50014 (1997) + Anhang 1 und 2 sowie EN 50020 (1994).

Spezielle Parameter für den oder die betroffenen Schutzarten:

Individuelle Prüfungen und Tests:

Keine

Español

- (A1) ANEXO
 (A2) CERTIFICADO DE EXAMEN DE TIPO CE
 LCIE 02 ATEX 6115 X (continuación)
 (A5) Condiciones especiales para la utilización segura

Los aparatos intrínsecamente seguros descritos anteriormente pueden instalarse en atmósferas explosivas.

El aparato debe combinarse únicamente con aparatos asociados intrínsecamente seguros, certificados, y dicha combinación debe ser compatible en lo que respecta a la seguridad intrínseca. (ver (A6)).

La clase de Temperatura T4 corresponde a un rango de temperatura ambiente de entre -20°C y +60°C.

Los siguientes sensores son aptos para la conexión con el bloque terminal TB2.

TB82PH/ML82PH

Sensores de la serie Advantage Combinación de sensores de pH
 Referencia de estado sólido Combinación de sensores de pH
 Sensor termocompensador externo

TB82EC/ML82EC

Sensores de conductividad de cuatro electrodos:

TB82TE/ML82TE

Sensor de conductividad de dos electrodos:

TB82TC/ML82TC

Sensor de conductividad toroidal:

- (A6) Requisitos Esenciales de Salud y Seguridad

El diseño del equipo cumple con las normas europeas EN 50014 (1997 + enmiendas 1 y 2) y EN 50020 (1994).

Parámetros específicos de los modos de protección involucrados:

Exámenes y pruebas individuales:

Ninguno.

(A1) ANNEXE

(A2) ATTESTATION D'EXAMEN CE DE TYPE LCIE 02 ATEX 6115 X (suite)

(A5) Conditions spéciales pour une utilisation sûre

Le matériel ci-dessus défini est un matériel de sécurité intrinsèque; il peut être placé en atmosphère explosible. Il ne peut être associé qu'à un matériel associé de sécurité intrinsèque certifié et cette association doit être compatible du point de vue de la sécurité intrinsèque (voir (A6)).
 Le classement en température T4 correspond à une gamme de températures ambiantes d'emploi comprises entre -20 °C et +60 °C.

Les capteurs désignés ci-dessous peuvent être reliés au connecteurs TB2.

TB82PH/ML82PH
 Capteurs de pH combinés- Série Advantage. TBX551, TBX556, TBX557, TBX561, TBX562, TBX564, TBX566 et TBX567.

Capteurs référence de pH transistorisés. TB551, TB556, TB557, TB561, TB562, TB564, TB566 et TB567.

Capteurs de compensation thermique externes. TB490 et TB590.

TB82EC/ML82EC
 Capteurs de conductivité à quatre électrodes : TB451, TB452, TB454, TB456, TB457, TB458, TB459, TB461, TB463, TB464, TB465, TB466, TB467, TB468, TB471, TB475 et TB477.

TB82TE/ML82TE
 Capteurs de conductivité à deux électrodes : TB25, TB254, TB256, TB26, TB264, TB27 et TB28.

TB82TC/ML82TC
 Capteur toroïdale de conductivité : TB404

(A6) Exigences essentielles en ce qui concerne la sécurité et la santé

La conception de cet équipement satisfait aux normes Européennes EN 50014 (1997 + amendements 1 et 2) et EN 50020 (1994).

Paramètres spécifiques du ou des modes de protection concernés :

TB/ML82PH/EC/TE : $U_i \leq 42 \text{ V}$; $I_i \leq 200 \text{ mA}$; $P_i \leq 1,2 \text{ W}$;
 $C_i \leq 2,5 \text{ nF}$; $t_i \leq 0,4 \text{ mH}$

TB/ML82TC : $U_i \leq 42 \text{ V}$; $I_i \leq 200 \text{ mA}$; $P_i \leq 1,2 \text{ W}$;
 $C_i \leq 5,2 \text{ nF}$; $t_i \leq 0,4 \text{ mH}$

Vérifications et épreuves individuelles :

Néant.

(A1) SCHEDULE

(A2) EC TYPE EXAMINATION CERTIFICATE LCIE 02 ATEX 6115 X (continued)

(A5) Special conditions for safe use

Above defined intrinsically safe apparatus can be installed in explosive atmospheres. The apparatus must only be combined with an associated intrinsically safe apparatus certified and this combination must be compatible as far as intrinsic safety is concerned (see (A6)).
 Temperature class T4 corresponds to an ambient temperature range from -20 °C to +60 °C.

The following sensors are for connexion to the terminal block TB2.

TB82PH/ML82PH
 Advantage Series Sensors Combination pH Sensors. TBX551, TBX556, TBX557, TBX561, TBX562, TBX564, TBX566 and TBX567.

Solid State Reference Combination pH sensors. TB551, TB556, TB557, TB561, TB562, TB564, TB566 and TB567.

External Thermocompensator Sensors. TB490 and TB590.

TB82EC/ML82EC
 Four-Electrode Conductivity Sensors : TB451, TB452, TB454, TB456, TB457, TB458, TB459, TB461, TB463, TB464, TB465, TB466, TB467, TB468, TB471, TB475 and TB477.

TB82TE/ML82TE
 Two Electrode Conductivity Sensors : TB25, TB254, TB256, TB26, TB264, TB27 and TB28.

TB82TC/ML82TC
 Toroidal Conductivity Sensor : TB404

(A6) Essential Health and Safety Requirements

The design of the equipment complies to European standards EN 50014 (1997 + amendments 1 and 2) and EN 50020 (1994).

Specific parameters of the mode(s) of protection concerned :

TB/ML82PH/EC/TE : $U_i \leq 42 \text{ V}$; $I_i \leq 200 \text{ mA}$; $P_i \leq 1,2 \text{ W}$;
 $C_i \leq 2,5 \text{ nF}$; $t_i \leq 0,4 \text{ mH}$

TB/ML82TC : $U_i \leq 42 \text{ V}$; $I_i \leq 200 \text{ mA}$; $P_i \leq 1,2 \text{ W}$;
 $C_i \leq 5,2 \text{ nF}$; $t_i \leq 0,4 \text{ mH}$

Individual examinations and tests :

None.



LCIE

<p>(A1) ATTESTATION D'EXAMEN DE TYPE LCIE 02 ATEX 6115 X du 11 septembre 2002</p> <p>AVENANT LCIE 02 ATEX 6115 X/01</p> <p>(A2) DESIGNATION DE L'EQUIPEMENT OU DU SYSTEME DE PROTECTION : Transmetteur de pH ou de conductivité Types : TB82.../ML82... Construit par : ABB Inc.</p> <p>(A3) OBJET DE L'AVENANT, DESCRIPTION DE L'APPAREIL OU DU SYTEME DE PROTECTION : - Adjonction de la version avec bus Foundation Fieldbus. Seules la carte d'alimentation et la carte du microprocesseur et afficheur sont différentes. - Autres changements mineurs n'affectant pas la sécurité intrinsèque. <u>Modification du marquage :</u> Inchangé. <u>Paramètres spécifiques du ou des modes de protection concernés :</u> Inchangés, mais avec en supplément : Version Foundation Fieldbus : Ui ≤ 24 V ; Ii ≤ 380 mA ; Pi ≤ 5,32 W ; Ci = 0 nF ; Li = 0 mH</p> <p>(A4) DOCUMENTS DESCRIPTIFS : Dossier technique N° A27-TB82ATEX-ER02-002B Rév. B du 3 juillet 2003. Ce dossier comprend 54 rubriques (131 pages).</p> <p>(A5) CONDITIONS SPECIALES POUR UNE UTILISATION SURE : Inchangées.</p> <p>(A6) VERIFICATIONS ET EPREUVES INDIVIDUELLES : Inchangées.</p> <p>(A7) EXIGENCES ESSENTIELLES EN CE QUI CONCERNE LA SECURITE ET LA SANTE : Inchangées. Fontenay-aux-Roses, le 9 octobre 2003</p>	<p>(A1) TYPE EXAMINATION CERTIFICATE LCIE 02 ATEX 6115 X dated September 11th, 2002</p> <p>VARIATION LCIE 02 ATEX 6115 X/01</p> <p>(A2) NAME OF EQUIPMENT OR PROTECTIVE SYSTEM : pH or conductivity transmitter Types : TB82.../ML82... Manufactured by : ABB Inc.</p> <p>(A3) SUBJECT OF THE VARIATION, DESCRIPTION OF EQUIPMENT OR PROTECTIVE SYSTEM : - Addition of the Foundation Fieldbus Version. Only the power supply board and the μP/display board are different. - Other minor changes which not affect intrinsic safety. <u>Modification of the marking :</u> Unchanged. <u>Specific parameters of the concerned mode(s) of protection :</u> Unchanged, but with the following addition : Foundation Fieldbus version : Ui ≤ 24 V ; Ii ≤ 380 mA ; Pi ≤ 5,32 W ; Ci = 0 nF ; Li = 0 mH</p> <p>(A4) DESCRIPTIVE DOCUMENTS : Technical file No. A27-TB82ATEX-ER02-002B Rev. B dated July 3rd, 2003. This file includes 54 items (131 pages).</p> <p>(A5) SPECIAL CONDITIONS FOR SAFE USE : Unchanged.</p> <p>(A6) INDIVIDUAL EXAMINATIONS AND TESTS : Unchanged.</p> <p>(A7) ESSENTIAL HEALTH AND SAFETY REQUIREMENTS : Unchanged.</p>
--	--

Le Directeur de l'organisme certificateur
 Manager of the certification body

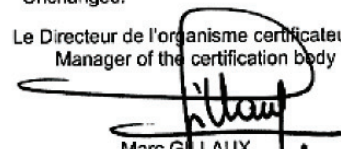

Marc G. LAUX
 Timbre sec/Dry seal

(B) Seul le texte en français peut engager la responsabilité de LCIE. Ce document ne peut être reproduit que dans son intégralité, sans aucune modification.
 The LCIE's liability applies only on the French text. This document may only be reproduced in full and without any change.

<p>LCIE Laboratoire Central des Industries Electriques Une société de Bureau Veritas</p>	<p>33, av du Général Leclerc BP 8 92266 Fontenay-aux-Roses cedex France</p>	<p>Tél : +33 1 40 95 60 60 Fax : +33 1 40 95 86 56 contact@lcie.fr www.lcie.fr</p>	<p>Société anonyme à directeur et conseil de surveillance au capital de 15 745 984 € RCS Nanterre B 408 363 174</p>
--	--	---	--



LCIE

(A1) ATTESTATION D'EXAMEN CE DE TYPE
LCIE 02 ATEX 6115 X du 11 septembre 2002

AVENANT LCIE 02 ATEX 6115 X/02

(A2) DESIGNATION DE L'EQUIPEMENT OU DU SYSTEME
DE PROTECTION :

Transmetteur de pH ou de conductivité
Types : TB82.../ML82...

Construit par : ABB Inc.

(A3) OBJET DE L'AVENANT, DESCRIPTION DE
L'APPAREIL OU DU SYTEME DE PROTECTION :

Options : Foundation Fieldbus and Profibus PA
Communication

Marquage : Inchangé.

(A4) DOCUMENTS DESCRIPTIFS :

Dossier technique N° A27-TB82ATEX-ER02-002C Rév. C du
03/12/2003.
Ce dossier comprend 61 rubriques (145 pages).

(A5) CONDITIONS SPECIALES POUR UNE UTILISATION
SURE :

Inchangées.

(A6) VERIFICATIONS ET EPREUVES INDIVIDUELLES :

Inchangées.

(A7) EXIGENCES ESSENTIELLES EN CE QUI
CONCERNE LA SECURITE ET LA SANTE :

Inchangées.

Paramètres spécifiques du ou des modes de protection
concernés :

Versionn Fieldbus :

Ui ≤ 24 V ; Ii ≤ 380 mA ; Pi ≤ 5,32 W ; Ci = 0 nF ; Li = 0 mH

(A1) EC TYPE EXAMINATION CERTIFICATE
LCIE 02 ATEX 6115 X dated September 11th, 2002

VARIATION LCIE 02 ATEX 6115 X/02

(A2) NAME OF EQUIPMENT OR PROTECTIVE SYSTEM :

pH or conductivity transmitter
Types : TB82.../ML82...

Manufactured by : ABB Inc.

(A3) SUBJECT OF THE VARIATION, DESCRIPTION OF
EQUIPMENT OR PROTECTIVE SYSTEM :

Foundation Fieldbus and Profibus PA Communication options

Marking : Unchanged.

(A4) DESCRIPTIVE DOCUMENTS :

Technical file No. A27-TB82ATEX-ER02-002C Rev. C dated
03/12/2003.
This file includes 61 items (145 pages).

(A5) SPECIAL CONDITIONS FOR SAFE USE :

Unchanged.

(A6) INDIVIDUAL EXAMINATIONS AND TESTS :

Unchanged.

(A7) ESSENTIAL HEALTH AND SAFETY REQUIREMENTS :

Unchanged.

Specific parameters of the concerned mode(s) of protection :

Fieldbus version :

Ui ≤ 24 V ; Ii ≤ 380 mA ; Pi ≤ 5,32 W ; Ci = 0 nF ; Li = 0 mH

Fontenay-aux-Roses, le 31 mars 2004

Le Directeur de l'organisme certificateur
Manager of the certification body

MICHEL BRÉNON

Timbre sec/Dry seal

Page 1/1

(8) Seul le texte en français peut engager la responsabilité du LCIE. Ce document ne peut être reproduit que dans son intégralité, sans aucune modification. A
The LCIE's liability applies only on the French text. This document may only be reproduced in full and without any change.

LCIE	33, av du Général Leclerc	Tél : +33 1 40 95 60 60	Société Anonyme
Laboratoire Central	BP 8	Fax : +33 1 40 95 86 56	au capital de 15 715 984 €
des Industries Electriques	92266 Fontenay-aux-Roses cedex	contact@lcie.fr	RCS Nanterre B 408 363 174
Une société de Bureau Veritas	France	www.lcie.fr	

1/1



LCIE

(A1) ATTESTATION D'EXAMEN CE DE TYPE
LCIE 02 ATEX 6115 X du 11 septembre 2002

(A1) EC TYPE EXAMINATION CERTIFICATE
LCIE 02 ATEX 6115 X dated September 11th, 2002

AVENANT LCIE 02 ATEX 6115 X/03

VARIATION LCIE 02 ATEX 6115 X/03

(A2) DESIGNATION DE L'EQUIPEMENT OU DU SYSTEME
DE PROTECTION :

Transmetteur de pH ou de conductivité
Types : TB82.../ML82...

Construit par : ABB Inc.

(A2) NAME OF EQUIPMENT OR PROTECTIVE SYSTEM :

pH or conductivity transmitter
Types : TB82.../ML82...

Manufactured by : ABB Inc.

(A3) OBJET DE L'AVENANT, DESCRIPTION DE
L'APPAREIL OU DU SYTEME DE PROTECTION :

Modifications de composants.
Modifications de plans.
Suppression du type xxDZ.
Correction de la valeur de Ci pour les versions deux fils
(4-20mA/HART).

Marquage : Inchangé.

(A3) SUBJECT OF THE VARIATION, DESCRIPTION OF
EQUIPMENT OR PROTECTIVE SYSTEM :

Modifications of components
Modifications of drawings.
Deletion of model type xx82DZ.
Correction to Ci parameter of two-wire (4-20 mA/HART) versions.

Marking : Unchanged.

(A4) DOCUMENTS DESCRIPTIFS :

Dossier technique N° A27-TB82ATEX-ER02-002D Rév. C du
12/01/2005.
Ce dossier comprend 61 rubriques (145 pages).

(A5) CONDITIONS SPECIALES POUR UNE UTILISATION
SURE :

Inchangées.

(A6) VERIFICATIONS ET EPREUVES INDIVIDUELLES :

Inchangées.

(A7) EXIGENCES ESSENTIELLES EN CE QUI
CONCERNE LA SECURITE ET LA SANTE :

Inchangées.

Paramètres spécifiques du ou des modes de protection
concernés :

Inchangés. Excepté pour la valeur de Ci des versions deux fils
(4-20 mA/HART) : Ci = 5,2 nF.

(A4) DESCRIPTIVE DOCUMENTS :

Technical file No. A27-TB82ATEX-ER02-002D Rev. D dated
12/01/2005.
This file includes 61 items (145 pages).

(A5) SPECIAL CONDITIONS FOR SAFE USE :

Unchanged.

(A6) INDIVIDUAL EXAMINATIONS AND TESTS :

Unchanged.

(A7) ESSENTIAL HEALTH AND SAFETY REQUIREMENTS :

Unchanged.

Specific parameters of the concerned mode(s) of protection :

Unchanged. Excepted for the Ci parameter for the two-wire
transmitter (4-20 mA/HART) versions : Ci = 5,2 nF.

Fontenay-aux-Roses, le 28 janvier 2005

Le Directeur de l'organisme certificateur
Manager of the certification body

Michel BRÉNON

Timbre sec/Dry seal

Page 1/1

(8) Seul le texte en français peut engager la responsabilité du LCIE. Ce document ne peut être reproduit que dans son intégralité, sans aucune modification.
The LCIE's liability applies only on the French text. This document may only be reproduced in full and without any change.

LCIE 35, av du Général Leclerc
Laboratoire Central BP 8
des Industries Electriques 92266 Fontenay-aux-Roses cedex
Une société de Bureau Veritas France

Tél : +33 1 40 95 60 60 Société Anonyme
Fax : +33 1 40 95 86 56 au capital de 15 745 981 €
contact@lcie.fr RCS Nanterre B 408 363 174
www.lcie.fr



L C I E

- | | |
|--|---|
| <p>1 AVENANT D'ATTESTATION D'EXAMEN CE DE TYPE</p> <p>2 Appareil ou système de protection destiné à être utilisé en atmosphères explosibles (Directive 94/9/CE)</p> <p>3 Numéro de l'avenant :
LCIE 02 ATEX 6115 X / 04</p> <p>4 Appareil ou système de protection :
Transmetteur de pH ou de conductivité
Type : TB82.../ML82...</p> <p>5 Demandeur : ABB, Inc.</p> <p>15 DESCRIPTION DE L'AVENANT</p> <ul style="list-style-type: none"> - Changement d'adresse : ABB, Inc. 9716 South Virginia Street, Suite E Reno, NV 89521 USA - Modifications mineures de composants - Mise à jour des documents , adjonction de capteurs <p>Les résultats des vérifications et essais figurent dans le rapport confidentiel N° 60054758/555247.</p> <p><u>Paramètres spécifiques du ou des modes de protection concerné(s) :</u>
Inchangés.</p> <p><u>Le marquage doit être :</u> Inchangé. Excepté pour l'adresse.</p> <p>16 DOCUMENTS DESCRIPTIFS</p> <p>Dossier de certification N° A27-TB82ATEX-ER02-002E rév. E du 10/01/2007.
Ce dossier comprend 61 rubriques (145 pages).</p> <p>17 CONDITIONS SPECIALES POUR UNE UTILISATION SURE</p> <p>Inchangées. Excepté pour :
<u>TB82PH/ML82PH</u>
Capteurs de pH combinés- Série Advantage, TBX551, TBX556, TBX557, TBX561, TBX562, TBX564, TBX566 et TBX567.</p> <p>Capteurs référence de pH transistorisés, TB551, TB556, TB557, TB561, TB562, TB564, TB566, TB567, AP10, AP20, AP30, 2867, 765, 766 et 767.</p> <p>Capteurs de compensation thermique externes, IB490 et TB590.</p> <p><u>TB82EC/ML82EC</u>
Capteurs de conductivité à quatre électrodes : TB451, TB452, TB454, TB456, TB457, TB458, TB459, TB461, TB463, TB464, TB465, TB466, TB467, TB468, TB471, TB475 et TB477.</p> <p><u>TB82TE/ML82TE</u>
Capteurs de conductivité à deux électrodes : TB25, TB254, TB256, TB26, TB264, TB27, TB28, 2045, 2077, 2278, 2025, 2078 et 2085.</p> <p><u>TB82TC/ML82TC</u>
Capteur toroïdale de conductivité : TB404</p> | <p>1 SUPPLEMENTARY EC TYPE EXAMINATION CERTIFICATE</p> <p>2 Equipment or protective system intended for use in potentially explosive atmospheres (Directive 94/9/EC)</p> <p>3 Supplementary certificate number :
LCIE 02 ATEX 6115 X / 04</p> <p>4 Equipment or protective system :
pH or conductivity transmitter
Type : TB82.../ML82...</p> <p>5 Applicant : ABB, Inc.</p> <p>15 DESCRIPTION OF THE SUPPLEMENTARY CERTIFICATE</p> <ul style="list-style-type: none"> - New company address: ABB, Inc. 9716 South Virginia Street, Suite E Reno, NV 89521 USA - Minor modifications of components - Update of documents, adding new sensors <p>The examination and test results are recorded in confidential report N° 60054758/555247.</p> <p><u>Specific parameters of the mode(s) of protection concerned:</u>
Unchanged</p> <p><u>The marking shall be :</u> Unchanged. Excepted for the address.</p> <p>16 DESCRIPTIVE DOCUMENTS</p> <p>Certification file N° A27-TB82ATEX-ER02-002E rev.E dated 10/01/2007.
This file includes 61 items (145 pages).</p> <p>17 SPECIAL CONDITIONS FOR SAFE USE</p> <p>Inchangées. Excepté pour :
<u>TB82PH/ML82PH</u>
Advantage Series Sensors Combination pH Sensors, TBX551, TBX556, TBX557, TBX561, TBX562, TBX564, TBX566 and TBX567.</p> <p>Solid State Reference Combination pH sensors, TB551, TB556, TB557, TB561, TB562, TB564, TB566, TB567, AP10, AP20, AP30, 2867, 765, 766 and 767.</p> <p>External Thermocompensator Sensors, TB490 and TB590.</p> <p><u>TB82EC/ML82EC</u>
Four-Electrode Conductivity Sensors : TB451, TB452, TB454, TB456, TB457, TB458, TB459, TB461, TB463, TB464, TB465, TB466, TB467, TB468, TB471, TB475 and TB477.</p> <p><u>TB82TE/ML82TE</u>
Two Electrode Conductivity Sensors : TB25, TB254, TB256, TB26, TB264, TB27, TB28, 2045, 2077, 2278, 2025, 2078 and 2085.</p> <p><u>TB82TC/ML82TC</u>
Toroidal Conductivity Sensor : TB404</p> |
|--|---|

Seul le texte en français peut engager la responsabilité du LCIE. Ce document ne peut être reproduit que dans son intégralité, sans aucune modification.
The LCIE's liability applies only on the French text. This document may only be reproduced in its entirety and without any change.

Page 1 sur 2
01A-Annexe ILLCE_typ_app_av - rev1.DOC

LCIE	33, av du Général Leclerc	Tel : +33 1 40 95 60 60	Société Anonyme
Laboratoire Central	BP 8	Fax : +33 1 40 95 56 56	au capital de 15 715 981 €
des Industries Electriques	92256 Fontenay-aux-Roses cedex	contact@lcie.fr	RCS Nanterre B 408 363 174
Une société de Bureau Veritas	France	www.lcie.fr	

1



- | | |
|--|--|
| <p>1 AVENANT D'ATTESTATION D'EXAMEN CE DE TYPE (suite)</p> <p>2 Appareil ou système de protection destiné à être utilisé en atmosphères explosibles (Directive 94/9/CE)</p> <p>3 Numéro de l'avenant :
LCIE 02 ATEX 6115 X / 04</p>
<p>18 EXIGENCES ESSENTIELLES DE SECURITE ET DE SANTE
Inchangées.</p> <p>19 VERIFICATIONS ET ESSAIS INDIVIDUELS
Néant.</p> | <p>1 SUPPLEMENTARY EC TYPE EXAMINATION CERTIFICATE (continued)</p> <p>2 Equipment or protective system intended for use in potentially explosive atmospheres (Directive 94/9/EC)</p> <p>3 Supplementary certificate number :
LCIE 02 ATEX 6115 X / 04</p>
<p>18 ESSENTIAL HEALTH AND SAFETY REQUIREMENTS
Unchanged.</p> <p>19 ROUTINE VERIFICATIONS AND TESTS
None.</p> |
|--|--|

Fontenay-aux-Roses, le 19 février 2007

Le responsable de certification ATEX
ATEX certification manager

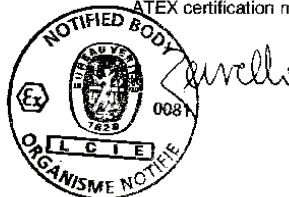

Seul le texte en français peut engager la responsabilité du LCIE. Ce document ne peut être reproduit que dans son intégralité, sans aucune modification.
The LCIE's liability applies only on the French text. This document may only be reproduced in its entirety and without any change.

Page 2 sur 2
01A-Annexe III_CE_typ_app_av - rev1.DOC

11/03

TRANSMITTER MOUNTING DETAILS



Warning.

For installation in Hazardous Areas, i.e. areas with danger of fire and/or explosion, irrespective of the protection mode used, the installation must be carried out in accordance with local authority regulations. Ensure also that the temperature of the transmitter does not exceed the value indicated in the Agency Approval Label.

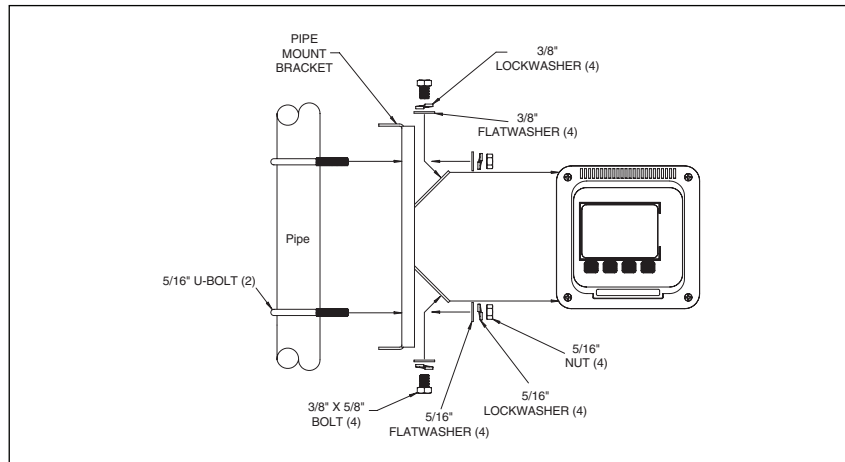

Figure 3 – Pipe Mounting Detail



Note.

When mounting the transmitter, choose a location that has ample clearance for the removal of the front bezel and rear cover. The location should provide easy access for maintenance procedures and not be in a highly corrosive environment. Excessive mechanical vibrations and shocks as well as relay and power switches should not be in the immediate area. Signal wiring should not be placed in conduit or open trays that contain power wiring for heavy electrical equipment.

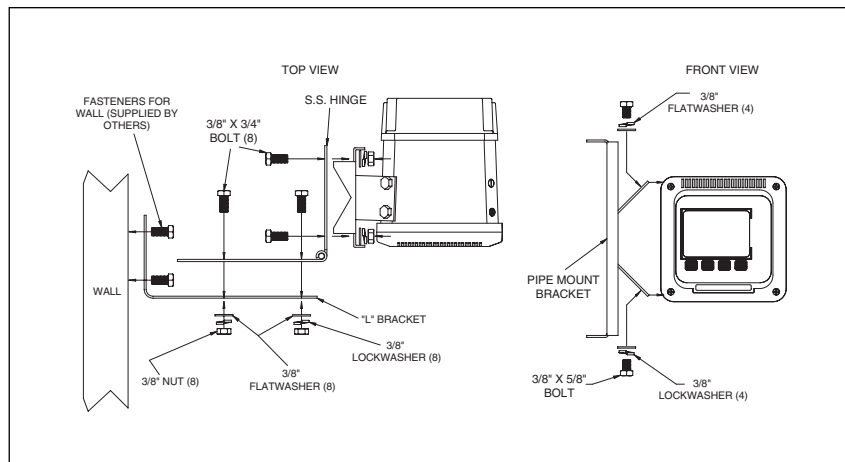

Figure 4 – Hinge Mounting Detail



Caution.

Besides the normal precautions for storage and handling of electronic equipment, the transmitter contains static sensitive devices. Since semiconductors can be damaged by the direct discharge of static electricity, avoid contact with terminal block conductors and electronic components on the circuit board.

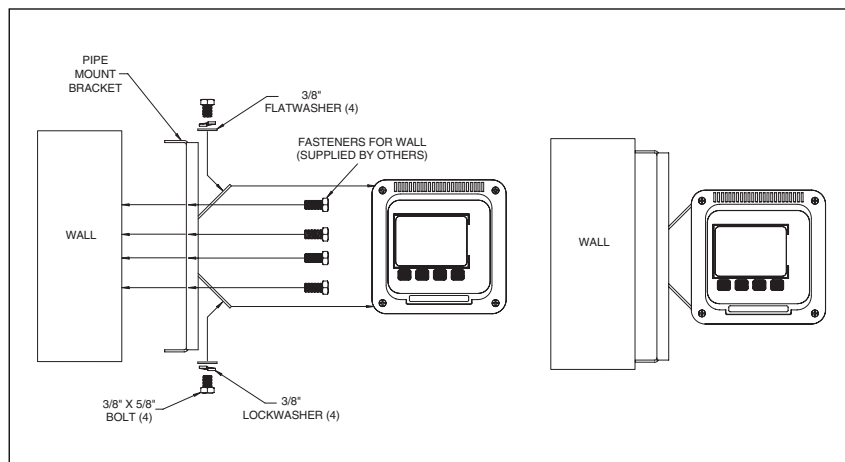

Figure 5 – Wall Mounting Detail

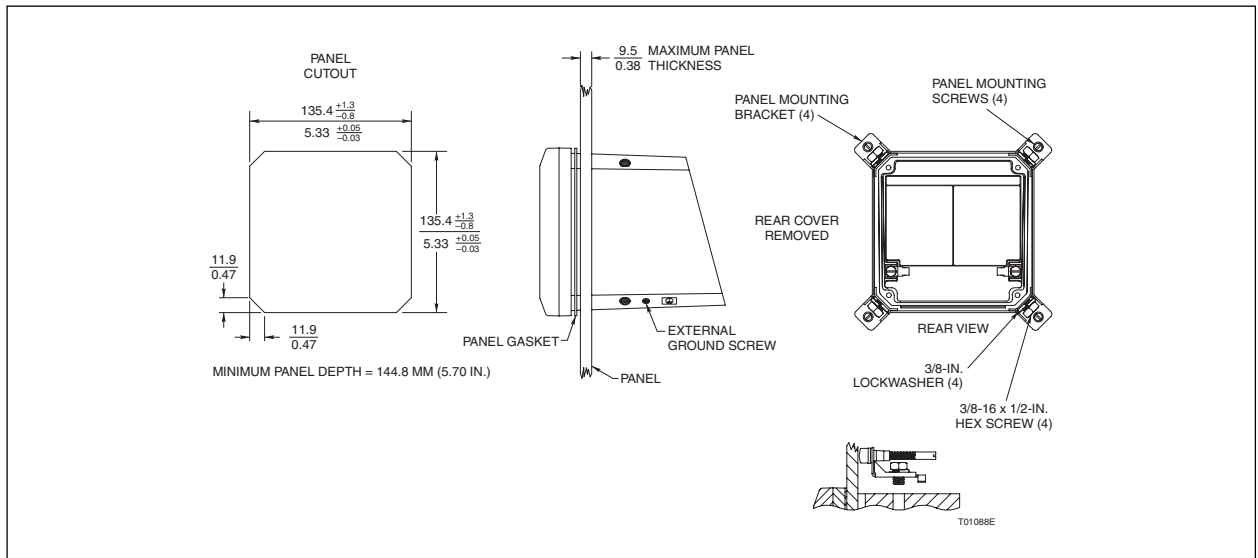

Figure 6 – Panel Mounting Detail

ELECTRICAL CONNECTIONS - Power Wiring



Warning.

Use this equipment only in those classes of hazardous locations listed on the nameplate. Uses in other hazardous locations can lead to unsafe conditions that can injure personnel and damage equipment.

The TB82PH Transmitter is powered by DC voltage. See the appropriate power requirements in the Specification Section for the particular type of TB82 Transmitter in use (Analog, HART, PROFIBUS or Foundation Fieldbus (FF)). Power is connected to the POWER/OUTPUT area on TB1, terminals 1 and 2 (see Figure 7).

The terminal blocks located in the rear of the transmitter accept wire sizes from 12 to 24 AWG. Pin-style terminations should be used for all connections. The terminal block label identifies all electrical connections and should be followed when wiring the transmitter.

Normal grounding practice is to terminate all grounds at the control room side, in which case the field side of the screen should be adequately protected to avoid contact with metallic objects. The transmitter case should be grounded. Ground connections are provided internally (in the terminal compartment) and externally.

For IS systems the grounding should be at the safety barrier earth connection. For bus-powered systems the grounding of the screen should be close to the power supply unit. The specific noise immunity and emitted interference are only guaranteed when bus screening is fully effective (e.g., ensuring that screening is maintained through any existing junction boxes.) Appropriate equipotential bonding must be provided to avoid differences in potential among the individual plant components.

To ensure fault-free communication on fieldbus (FF or PA) installations, the bus must be properly terminated at both ends. Only approved bus terminators must be used for intrinsically safe circuits.

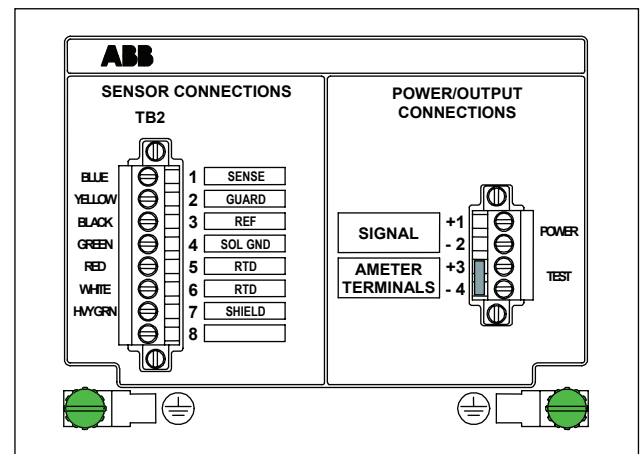

Figure 7 - Power Connections

SENSOR CONNECTIONS – Model TB5 & TBX5 Sensor Connections

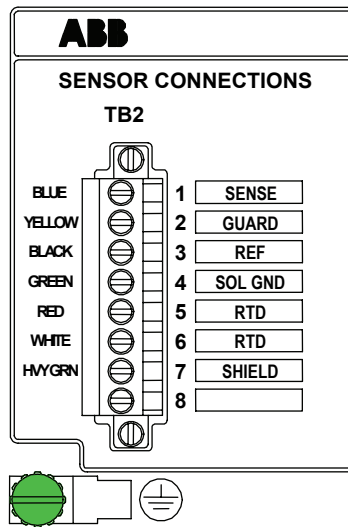

Figure 8 – Sensor Connections

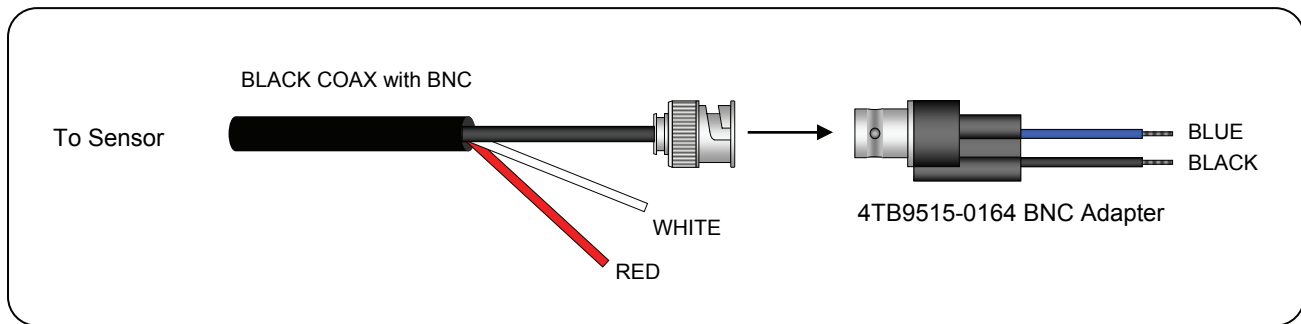

Figure 9 - TB5 BNC cable & BNC adapter

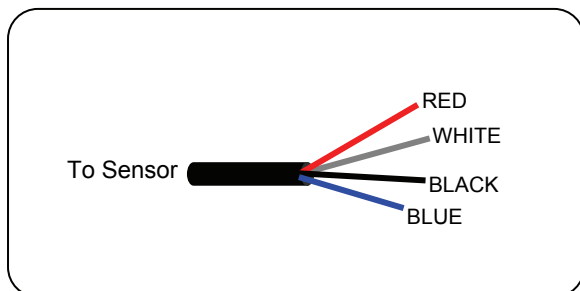

Figure 10 – TB5 cable with pin leads

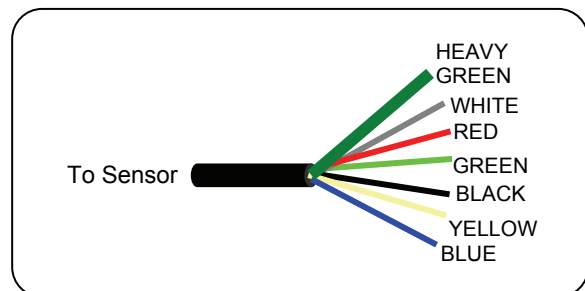

Figure 11 - TBX5 Advantage Sensor Cable

AP100, AP200, AP300 7660 and 7650 sensors have different color-coding in the cable assemblies than TB5 and TBX5 sensors. Use the table below to properly connect the sensor cable to the TB82PH.

TB82PH Terminal TB2			ABB Sensor Models					
Color	Number	Description	TB5	TBX5	AP100 ³	AP121/AP200	AP300	7650/7660
Blue	1	Measuring electrode	Blue ¹	Blue	Clear	Clear	Blue	Clear
Yellow	2	Shield for measuring electrode	None	Yellow	None	Red	None	None
Black	3	Reference	Black ¹	Black	Black	Blue	Black	Black
Green	4	Solution (diagnostic) Ground	None	Green	None	Green/Yellow	None	None
Red ²	5	RTD	Red	Red	Red	Gray & White	Red	Red ⁴ (2 total)
White ²	6	RTD	White	White	White	Green	White	White
Heavy Green	7	Shield (Screen)	None	Heavy Green (Shield)	None	None	None	Yellow
None	8	Not Used	None	None	None	None	None	None

Notes:

1. BNC adapter required on sensors provided with BNC termination (See **Figure 9**).
2. Red and White wires not present on sensors sold without temperature compensators
3. Cut away and discard gray wire on AP100 sensors (if present)
4. Place both red wires in terminal 5

*** Note.**
 TB5, AP100, AP300 and 7650/7660 sensors do not have a solution ground rod required to fully utilize all the TB82PH on-line sensor diagnostics. When configuring the transmitter for use with these sensors the DIAGS (diagnostics) choice must be set to OFF. See the Configure Mode section for details.

*** Note.**
 If an automatic temperature compensator is not used the TB82PH must be configured for manual temperature compensation. See the Configure Mode section for details.

OPERATING PROCEDURES

Figure 12 shows the TB82PH keypad and display with all possible icons in the display activated. For any given operation only the icons involved in the operation will be shown.

Key Functions

Exit to MEASURE - Escapes back to the Measure Mode from all other modes or programming states of operation.

FAULT Info - Accesses information on diagnostic or error conditions.

SELECT - Selects the mode or programming state of operation shown in the secondary display region

ENTER - Accepts the mode or programming state of operation shown in the secondary display region

NEXT - Increments through a series of programming states

YES - Affirms the action that is about to take place

NO - Denies the action that is about to take place.

MENU - Increments through the modes of operation

▲ Increases numerals & moves through a series of parameters

▶ Moves the flashing data entry value one space to the right

▼ Decreases numeric values & moves through a series of parameters

Figure 13 shows the TB82PH in the MEASURE mode of operation. Pressing the key at the far right, underneath the MENU icon, provides access to all other instrument functions.

Figure 14 shows the display after the MENU key has been pressed once. The CALIBRATE menu can now be accessed by pressing the key underneath the SELECT icon. If the MENU key is pressed **again** the display will change to the next menu function choice, OUT/HOLD. Pressing again will activate the CONFIGURE menu choice, and so on.

There are six MENU functions:

MEASURE - Normal operational display

CALIBRATE - Allows calibration of the pH (ORP) and temperature sensors, restoring calibration to the original factory values, tuning of the analog output and also allows the ability to view or change the sensor's slope and offset.

OUT/HOLD - Allows the output to be re-ranged, held or released (Analog version only)

CONFIGURE - Sets up how the transmitter operates

SECURITY - Sets password protection to the CONFIGURE, CALIBRATE and OUTPUT menus

DISPLAY - Displays temperature in °F or °C, current output in mA, reference impedance, mV input, spike output status and software revision. Sets what will be displayed under the secondary display when in the measure mode.

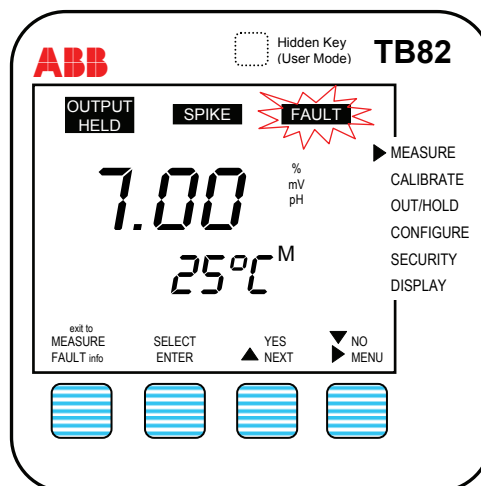

Figure 12

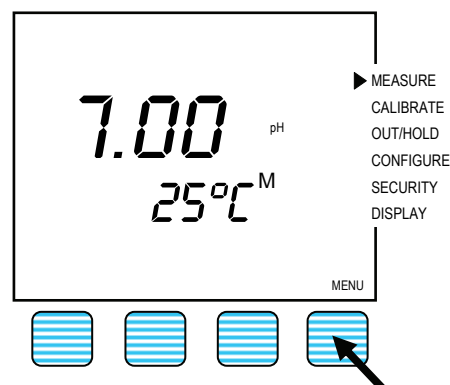

Figure 13

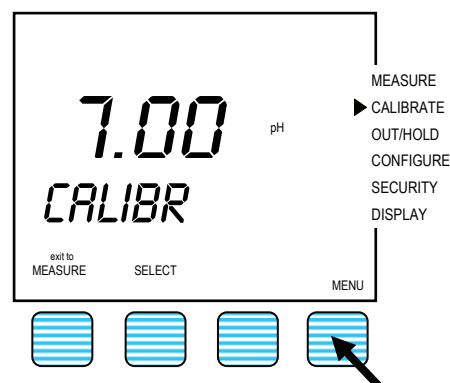

Figure 14

Commissioning the Instrument

To commission the TB82:

1. Configure the instrument as required for the application.
2. Calibrate the sensor(s).
3. Set up parameters on the receiving devices (e.g. PLC, DCS recorder) to properly recognize the TB82 outputs.

Flow Chart For Basic Operation Mode

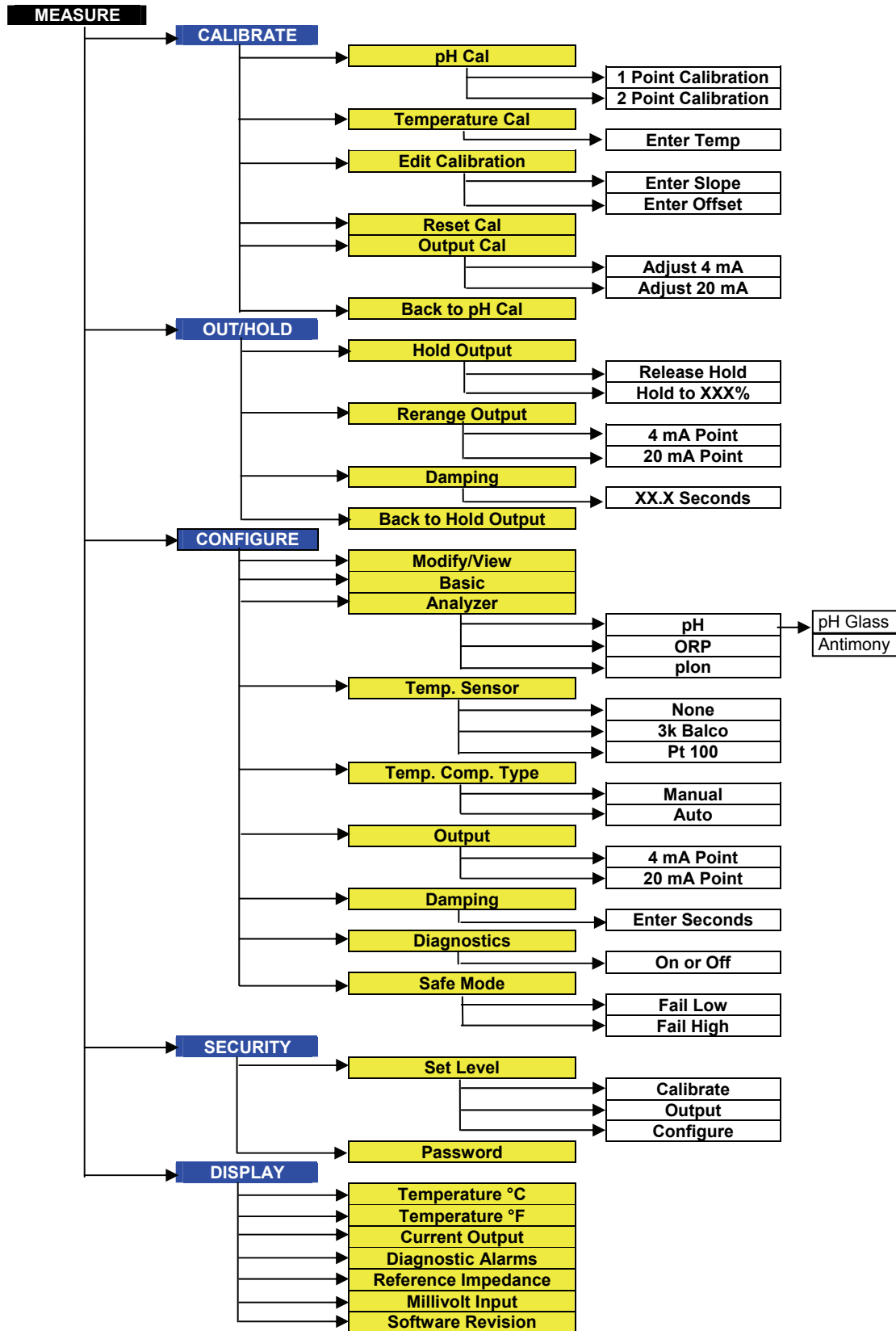

CONFIGURE MODE

Before the instrument can be put into a process measurement loop it must be configured. The TB82PH Transmitter operation (non-fieldbus versions) can be set in either a BASIC or ADVANCED Mode. BASIC mode is sufficient for 95% of all measurements. ADVANCED functions are described in *Italic* print in the 'alternatives' section of the default configuration table and in the 'Configure Mode - Flow Chart for ADVANCED Mode' section. **Figures 15** through **25** show typical screen flows for a BASIC pH Configuration.

Default Configuration

Parameter	Default	Alternative
Mode	BASIC	ADVANCED
Analyzer	pH	ORP, plon, <i>Ion Concentration</i>
Analyzer input	pH Glass	Antimony, <i>Custom sensor</i> <i>Reference Impedance</i>
Temperature Sensor	None	3K Balco Pt100 RTD
Temperature Compensation Type	Manual	Auto, <i>Auto Solution</i>
Output	4 mA = 0.00 pH 20 mA = 14.00 pH	Any 1 pH to 16 pH span, any span above 100 mV from -1999 mV to +1999 mV, <i>non-linear function generator,</i>
Damping	00.5 seconds	Adjustable to 99.9 seconds
Diagnostics	Off	On
Safe Mode*	Fail low	Fail high
Spike*	0% Spike Magnitude	0 to 100% magnitude

Note: Alternatives in *Italics* are available in ADVANCED mode only
* Safe Mode and Spike functions not available on fieldbus versions

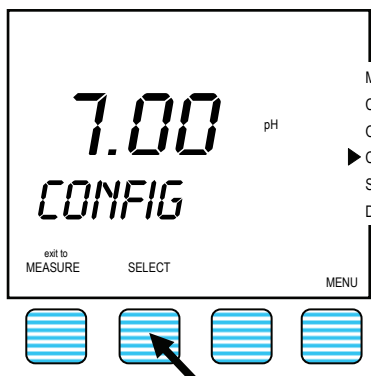

Figure 15

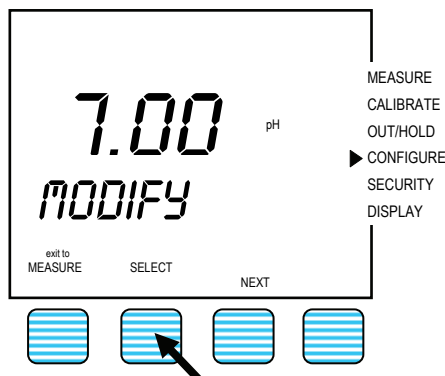

Figure 16

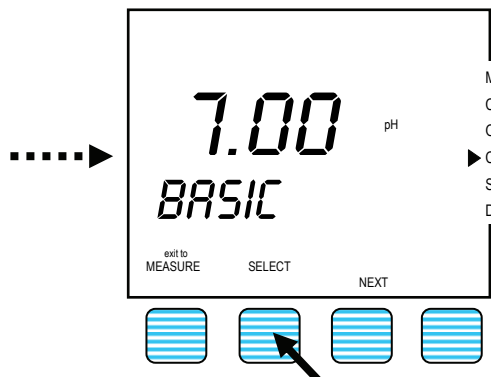

Figure 17

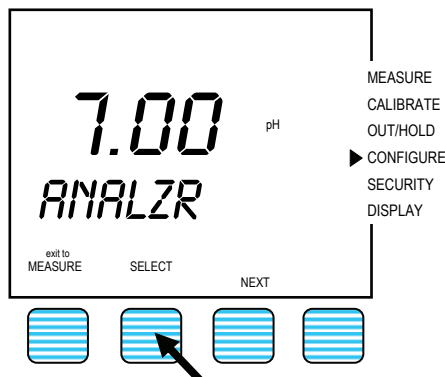

Figure 18

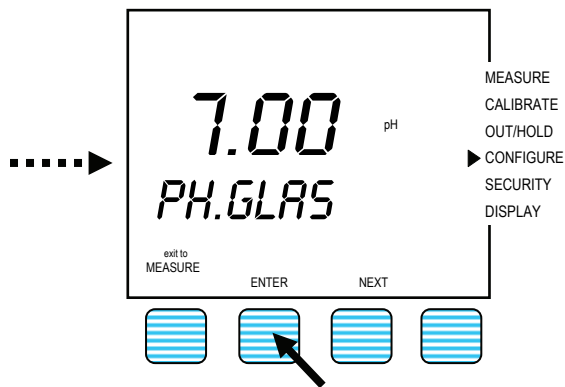

Figure 19

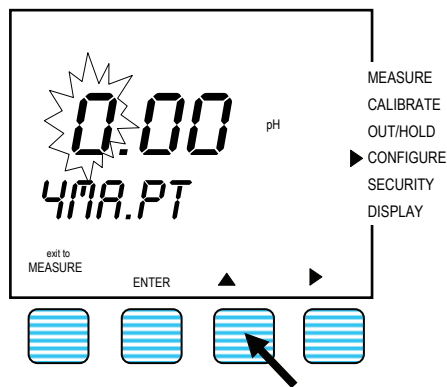

Figure 20

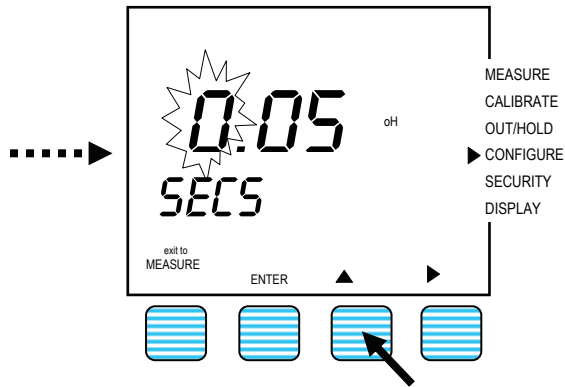

Figure 21

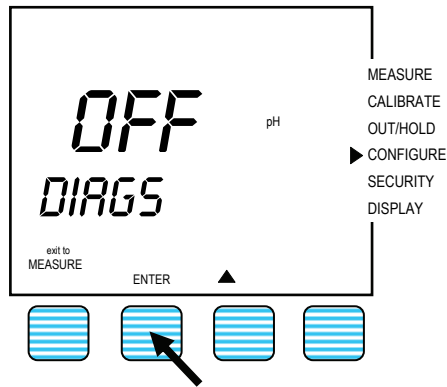

Figure 22

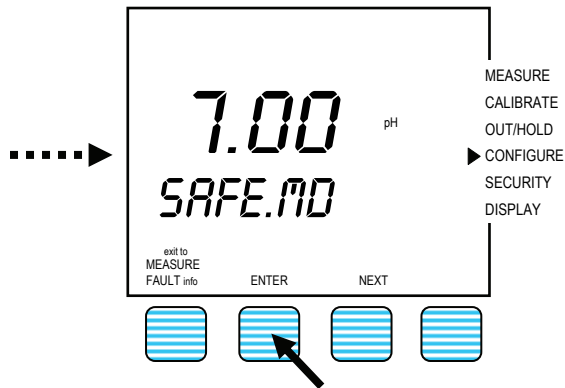

Figure 23

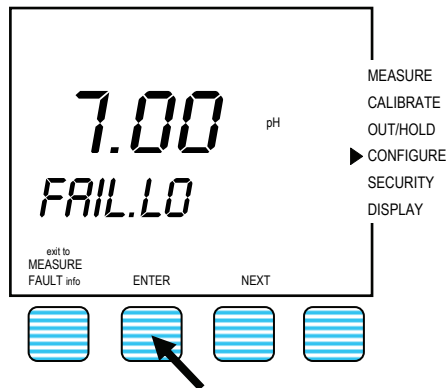

Figure 24

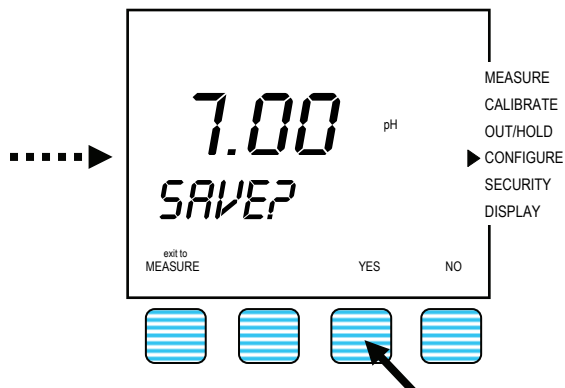
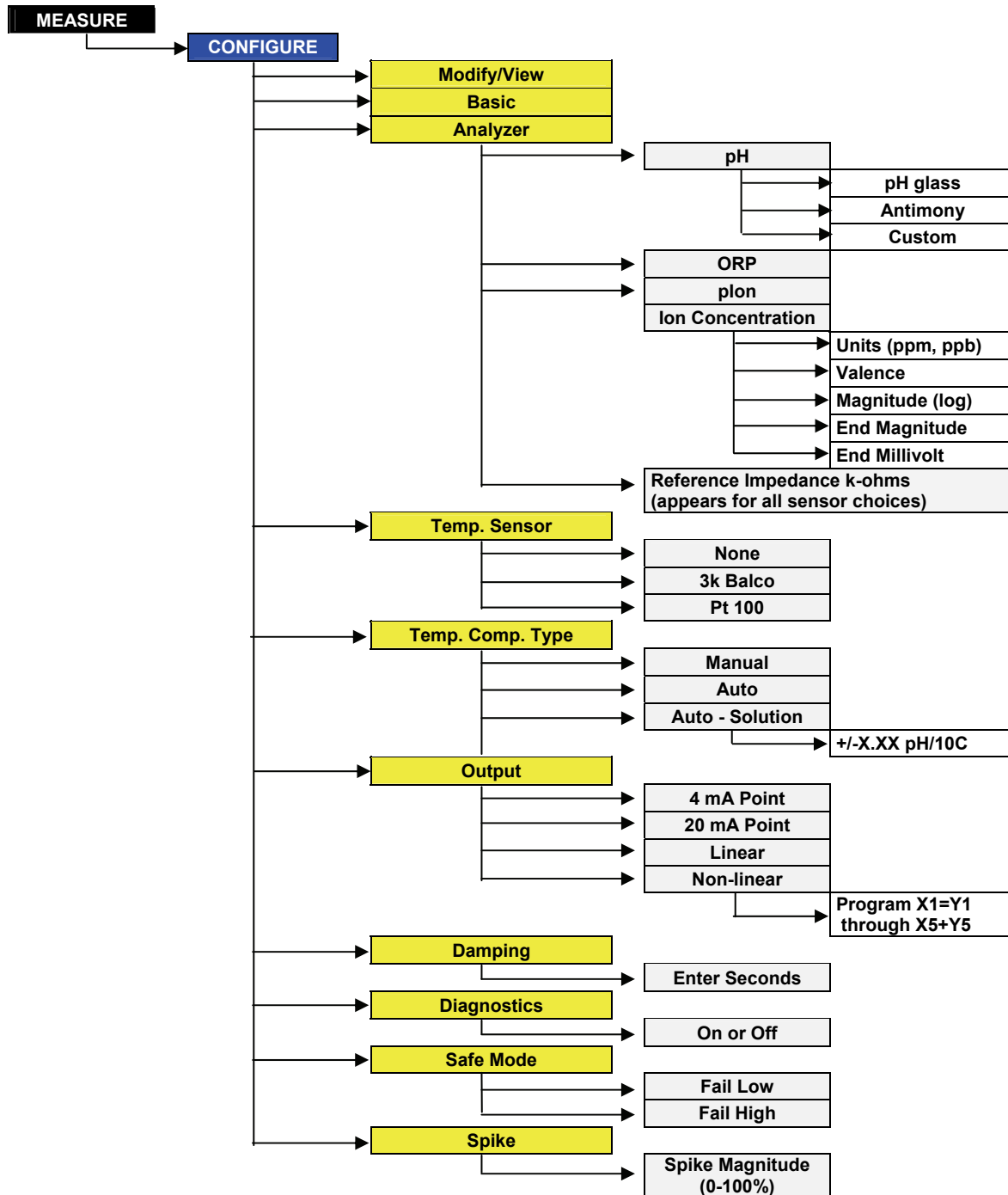

Figure 25

Caution.
 If a programming change has been made, pressing the Exit to MEASURE key will activate the SAVE? display (Figure 25). YES and NO keys will also appear. Press the YES key to save the changes. If the NO key is pressed any configuration or programming changes will not be saved.

Note.
 Diagnostics is a function valid only with a TBX5 Advantage pH sensors or an AP200 with a solution ground rod that is connected to Terminal TB2-4 (green, SOL GND). Diagnostics must be turned 'OFF' if TB5, AP100, AP300, 7650/7660, ORP or sensors without an integral solution ground are used.

Flow Chart For Advanced Mode



CALIBRATE MODE

Before an instrument can properly measure pH the sensor must be calibrated to the instrument. Periodic update calibrations must be performed during the time the sensor is in service. The frequency of re-calibration is application dependent. This mode also defines calibration of the temperature input and fine tuning the 4-20 mA output for non-fieldbus versions.

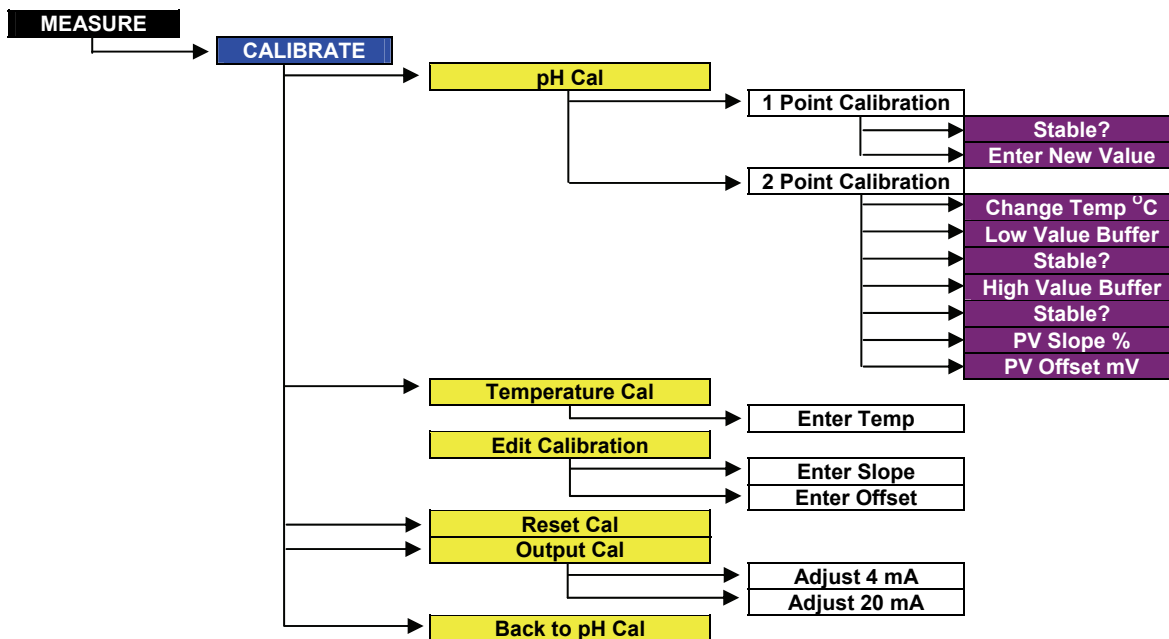

Caution.
 The Reset Calibrate State will reset all calibration values; therefore, the process sensor and temperature sensor will require calibration after performing the Reset Calibrate procedure.

OUTPUT/HOLD MODE

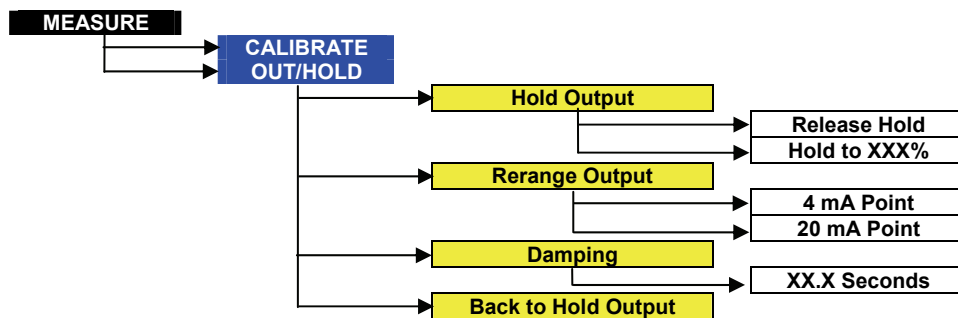

Output/Hold screen flow only valid for non-fieldbus versions.

SECURITY MODE

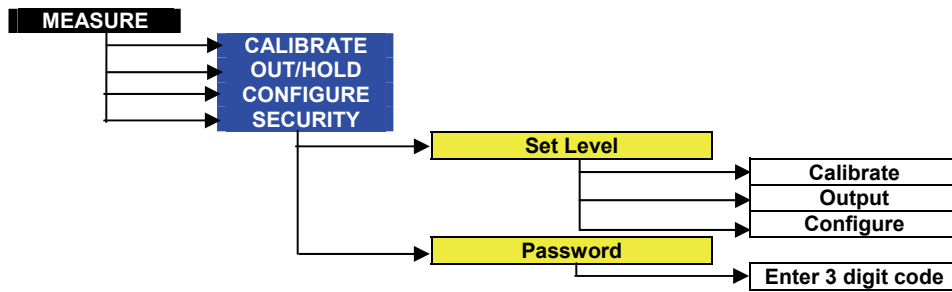

SECONDARY DISPLAY MODE

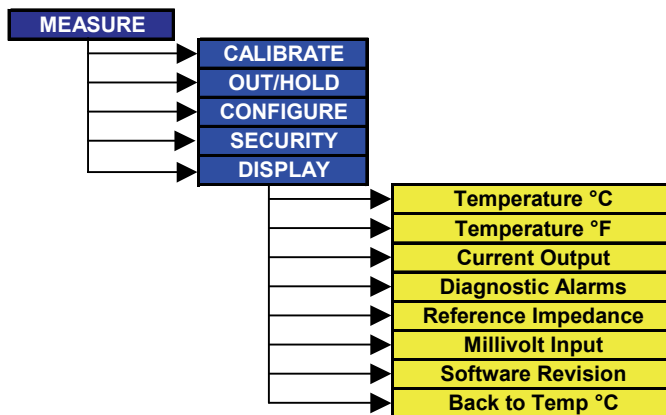

*** Note.**
 If an 'M' appears after the temperature display (e.g. 25°C^M) the TB82PH is programmed for manual temperature compensation (default 25°C).

MAINTENANCE

Preventative Maintenance Tasks	Interval (months)
Check, tighten and clean all wiring and connections	12
Clean and lubricate all gaskets and o-rings	Each time seals are disturbed
Analyzer Validation	Per user's requirements (minimum 12)
Clean and inspect sensor	As required by application (minimum monthly)
Sensor calibration	As required by application (minimum monthly)

DISMANTLING AND RE-ASSEMBLY

Warning.
Substitution of any components other than those assemblies listed in this section will compromise the certification listed on the transmitter nameplate. Invalidating the certifications can lead to unsafe conditions that can injure personnel and damage equipment.

Caution.
Dismantling and reassembly should not be carried out on site because of the risk of damage to components and printed circuits. The dismantling and reassembly procedures should be carried out in the listed order to avoid instrument damage.

Dismantling

1. Use the bladed screwdriver to loosen the four captive screws that secure the Front Bezel and/or Rear Cover Assemblies (depending on which component is being replaced) and remove the cover(s).
2. Remove Power Supply and/or Input PCB Assemblies by unscrewing the two Phillips screws and unplug the assemblies from their connectors.

3. Remove Microprocessor/Display PCB Assembly by unscrewing the four Phillips screws and unplug the keypad cable by lifting the locking arms on the side of the connector and remove the cable from the connector.
4. Remove the cable hubs by screwing the retaining nut and removing the hub from the Shell Assembly.

Reassembly

Check that the gaskets are not damaged and have a thin layer of silicone grease. If the gaskets are damaged, replace gaskets.

1. Install the Microprocessor/Display by securing the assembly with the four Phillips screws and installing the keypad cable into the connector and locking it into place by pushing down the two locking arms on the side of the connector.
2. Install the Power Supply and/or Input PCB Assemblies into their respective connector and secure the assemblies with the two Phillips screws per assembly.
3. Attach cable hubs by installing the gaskets onto the hubs and insert the hubs into the ports in the Shell assembly. Secure the hubs by tightening the nut onto the hub threads.
4. Install the Front Bezel and/or Rear Cover Assemblies and secure by tightening the four captive screws per assembly using a bladed screwdriver.

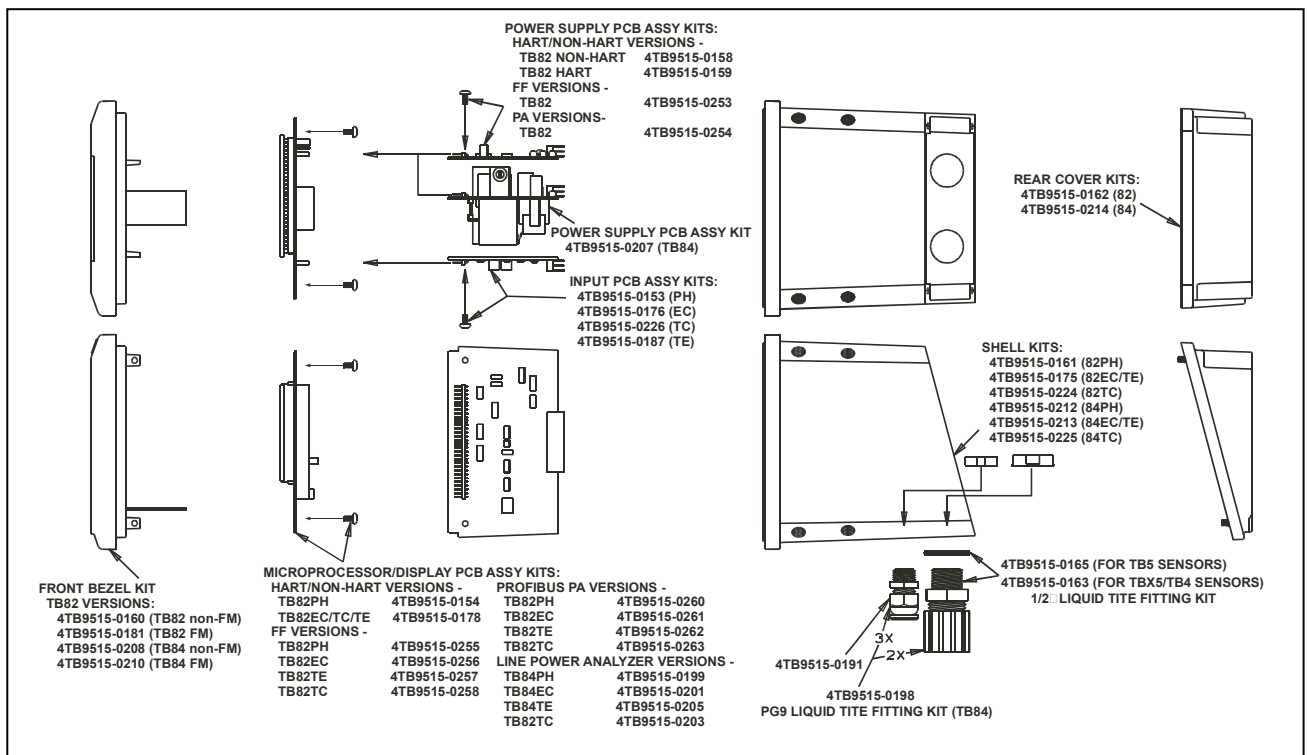

Figure 26 - TB82PH Transmitter Exploded View

SPECIFICATIONS

Property	Characteristic/Value
Process Display Range pH ORP pION Temperature	-2.00 to +16.00 pH -1999 to +1999 mV -1999 to +1999 mV 0 to 140°C
Power Requirements Analog HART Versions PROFIBUS PA FOUNDATION Fieldbus (FF)	14.0 to 55 VDC (14.0 to 42 VDC for agency certified applications). See Figure 27 below 14.0 to 55 VDC (14.0 to 42 VDC for agency certified applications). See Figure 27 below 9 to 32 VDC (9 to 24 VDC for agency certified applications) 15 mA quiescent current 9 to 32 VDC (9 to 24 VDC for agency certified applications) 15 mA quiescent current
Ambient Temperature Effect pH ORP pION Temperature	±0.007 pH/°C @ 95% Relative Humidity ±0.4 mV/°C @ 95% Relative Humidity ±0.4 mV/°C @ 95% Relative Humidity ±0.16°C/°C @ 95% Relative Humidity
Maximum Sensor Cable Length	100 ft (30.5 m)
Environmental Operating temperature LCD Range Storage temperature	-20° to 60°C (-4° to 140°F) -20° to 60°C (-4° to 140°F) -40° to 70°C (-40° to 158°F)
Enclosure Classification	NEMA 4X IP65
Size Height Minimum panel depth Maximum panel cutout Recommended panel cutout	144 mm high x 144 mm wide x 171 mm long (5.67 in. high x 5.67 in. wide x 6.75 in. long) 145 mm (5.70 in.) 136.7 mm x 136.7 mm (5.38 in. x 5.38 in.) 135 mm x 135 mm (5.33 in. x 5.33 in.)
Weight	1.9 kg (4.2 lb) without mounting hardware 3.4 kg (7.5 lb) with Pipe Mounting Hardware

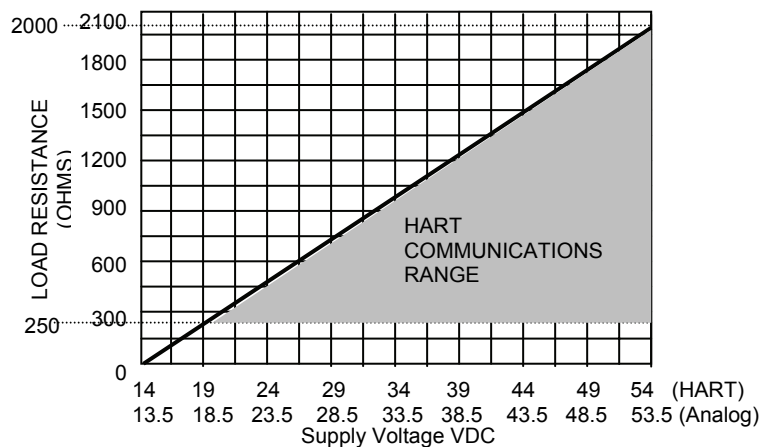

Figure 27 – Supply Voltage Requirements, HART and Analog Versions

Products and customer support

Automation Systems

For the following industries:

- Chemical & Pharmaceutical
- Food & Beverage
- Manufacturing
- Metals and Minerals
- Oil, Gas & Petrochemical
- Pulp and Paper

Drives and Motors

- AC and DC Drives, AC and DC Machines, AC Motors to 1kV
- Drive Systems
- Force Measurement
- Servo Drives

Controllers & Recorders

- Single and Multi-loop Controllers
- Circular Chart and Strip Chart Recorders
- Paperless Recorders
- Process Indicators

Flexible Automation

- Industrial Robots and Robot Systems

Flow Measurement

- Electromagnetic Flowmeters
- Mass Flowmeters
- Turbine Flowmeters
- Wedge Flow Elements

Marine Systems & Turbochargers

- Electrical Systems
- Marine Equipment
- Offshore Retrofit and Refurbishment

Process Analytics

- Process Gas Analysis
- Systems Integration

Transmitters

- Pressure
- Temperature
- Level
- Interface Modules

Valves, Actuators and Positioners

- Control Valves
- Actuators
- Positioners

Water, Gas & Industrial Analytics Instrumentation

- pH, Conductivity and Dissolved Oxygen Transmitters and Sensors
- Ammonia, Nitrate, Phosphate, Silica, Sodium, Chloride, Fluoride, Dissolved Oxygen and Hydrazine Analyzers
- Zirconia Oxygen Analyzers, Katharometers, Hydrogen Purity and Purge-gas Monitors, Thermal Conductivity

Customer support

We provide a comprehensive after sales service via a Worldwide Service Organization. Contact one of the following offices for details on your nearest Service and Repair Centre.

USA

ABB Inc.

Tel: +1 800 HELP 365 (435 7365)

Fax: +1 860 298 7669

UK

ABB Limited

Tel: +44 (0)1453 826661

Fax: +44 (0)1453 829671

China

ABB Engineering (Shanghai) Limited

Tel: +86 (0) 21 6105 6666

Fax: +86 (0) 21 6105 6992

Client Warranty

Prior to installation, the equipment referred to in this manual must be stored in a clean, dry environment, in accordance with the Company's published specification. Periodic checks must be made on the equipment's condition. In the event of a failure under warranty, the following documentation must be provided as substantiation:

- A listing evidencing process operation and alarm logs at time of failure.
- Copies of all storage, installation, operating and maintenance records relating to the alleged faulty unit.

Contact us

ABB Inc.

Process Automation

843 N Jefferson Street
PO Box 831
Lewisburg 24901-9509
USA

Tel: +1 304 647 4358

Fax: +1 304 645 4236

ABB Limited

Process Automation

Oldends Lane
Stonehouse
Gloucestershire GL10 3TA
UK

Tel: +44 1453 826 661

Fax: +44 1453 829 671

ABB Engineering (Shanghai) Ltd.

Process Automation

No5, Lane 369, Chuangye Road
201319, Shanghai
P.R. China

Phone: +86 (0) 21 6105 6666

Fax: +86 (0) 21 6105 6992

www.abb.com

Note

We reserve the right to make technical changes or modify the contents of this document without prior notice. With regard to purchase orders, the agreed particulars shall prevail. ABB does not accept any responsibility whatsoever for potential errors or possible lack of information in this document.

We reserve all rights in this document and in the subject matter and illustrations contained therein. Any reproduction, disclosure to third parties or utilization of its contents in whole or in parts – is forbidden without prior written consent of ABB.

Copyright© 2012 ABB

All rights reserved

TB82PH-ATEX-EN-C



Sales



Service



Software