

ECHELLE 1:2

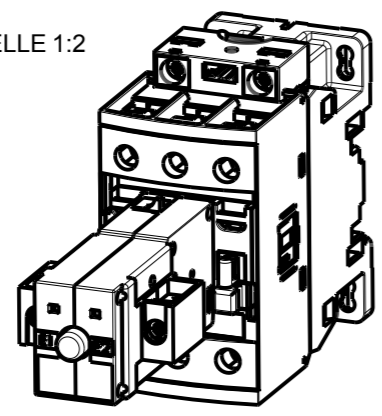

(*) : minimum distance to grounded component

DIMENSIONS+DRILLING/AF26...38TRI+WB75		1SBB505098R1101	-	-	-	-
Part name		Part number	Material	Heat treatment	Surface treatment	Finishing
Associated standards :						
SQR Number: -		masse (g) :	density (g/cm3) :	1,000	Thickness (mm):	0,0
Geometry without dimensions		Chamfer: -	Main draft: -	Angle Tol: -	Round edge: -	
A.1	CREATION DE PLAN	28/02/2012	-	Stephane Bovis		-
Modif	Description	DATE	N°ECN	Author	Control	
ABB		State : Conception		Observations: -		
Author: Bovis S		Creation: 28/02/2012	Control: -	First ECN: -	Scale: 1:1	Main Tol: -
Title : STAR		Running number		Doc	Size	Type
DIMENSIONS+DRILLING/AF26...38TRI+WB75		1SBB505098D3501		N°Page	Rev.lte	
						A.1