Wireless Controller ARC600

Product Guide



Contents

1. Description.....	3	9. Mounting.....	20
2. Complete communication system.....	4	10. Ordering data.....	20
3. Application.....	5	11. Accessories and ordering data.....	20
4. Battery condition monitoring.....	9	12. Tools.....	20
5. Motor overload protection.....	9	13. Terminal diagrams.....	21
6. Physical interfaces.....	10	14. References.....	22
7. Communication.....	14	15. Document revision history.....	23
8. Technical data.....	15		

Disclaimer

The information in this document is subject to change without notice and should not be construed as a commitment by ABB. ABB assumes no responsibility for any errors that may appear in this document.

© Copyright 2019 ABB.

All rights reserved.

Trademarks

ABB is a registered trademark of the ABB Group. All other brand or product names mentioned in this document may be trademarks or registered trademarks of their respective holders.

1. Description

Wireless Controller ARC600 is a compact, solution based device for remote controlling and monitoring of secondary substations, such as network disconnectors, load break switches and ring main units (RMU) in distribution networks. It enables the SCADA system to wirelessly monitor and control the field devices over the public communication infrastructure (cellular network). Wireless Controller ARC600 utilizes the built-in wireless communication features for reliable and secure end-to-end communication providing remote monitoring and control of three switching devices and can be expanded as required by using external I/O expansion modules.

The use of Wireless Controller ARC600 in distribution networks improves the quality of power distribution and reduces the outage time in the affected areas. Areas directly adjacent to these affected areas show reduced outages and overall effects.

This also reduces the capital expenditures in the distribution network by allowing integration of legacy devices and contributes to more direct cost savings by facilitating preventative maintenance. The operational expenditure can be reduced by lowering the System Average Interruption Duration Index (SAIDI) and System Average Interruption Frequency Index (SAIFI), resulting in lower penalties for undelivered energy. Wireless Controller ARC600 is also ideally suited to be retrofitted to existing applications thus enabling the remote control of these devices and further extending the life cycle of the switching devices itself.

Typically, the IEC-104 protocol is utilized for communication to the SCADA system but for the existing installations with a IEC-101 line or modem, Wireless Controller ARC600 supports also IEC-101 communication (including dial-up) to the SCADA system.

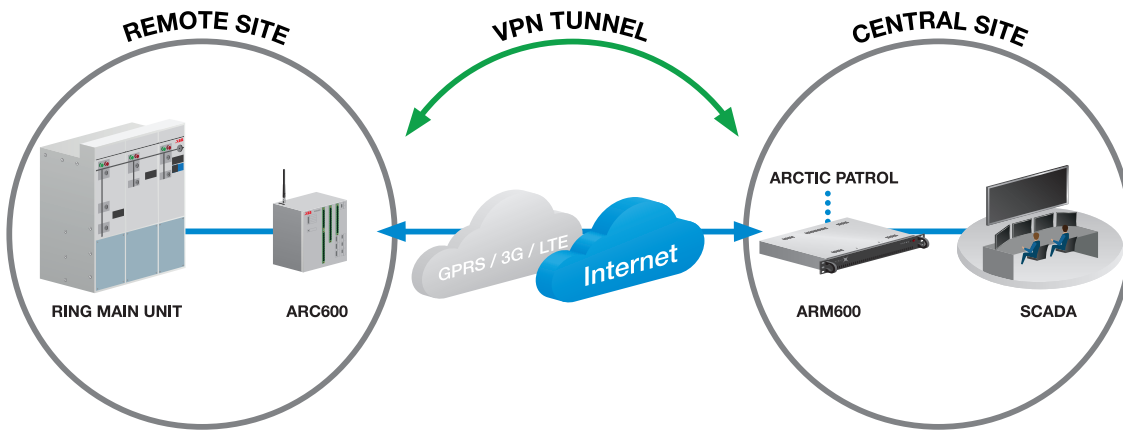

Figure 1. Communication system overview with Wireless Controller ARC600 and ring main unit

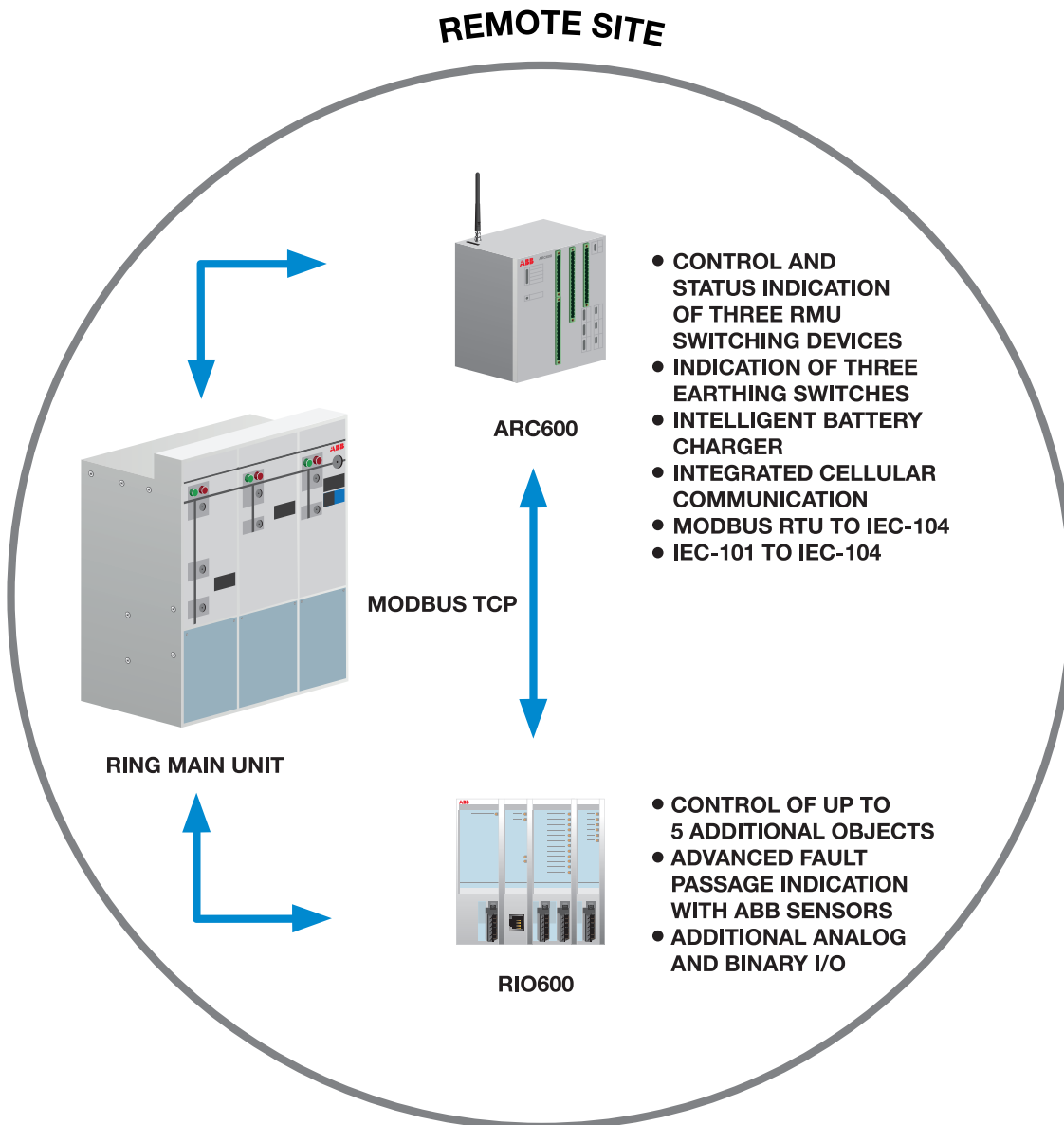

Figure 2. Wireless Controller ARC600 at remote site connected with ring main unit and RIO600. RTU monitoring and control combined with directional fault passage indication example.

2. Complete communication system

Wireless Controller ARC600 is typically part of a complete communication system which consists of Arctic 600 series gateways or controllers and a central M2M Gateway ARM600 communication server. The M2M gateway is an essential part of the total communication solution and offers features that are needed to build a reliable end-to-end communication system.

- Static IP addressing for Arctic 600 series devices – Possibility to use operator independent standard SIM cards
- VPN Concentrator – Secure communication between a central location and remote sites
- Arctic Patrol – Centralized device management application for the Arctic 600 series devices monitoring and controlling
- Firewall – A network security system to control the incoming and outgoing network traffic

3. Application

The functionalities of Wireless Controller ARC600 have been developed to monitor and control switching devices inside a secondary substation. Connected to the central control system (SCADA/DMS) that manages the utility network, they serve as the core of the secondary substation automation system.

Key features

- Highly reliable control and monitoring of up to three switching devices per ARC600
 - Status information of three switching devices and three earthing disconnectors
 - Disconnector position and earthing status indications with front LEDs
 - Local and remote use of the disconnectors
- Overload protection of actuator motors
 - Load current measured in the motor circuit
 - Current limit based motor overload protection (software fuse)
 - Measurement of disconnector open and close times
- Fault Passage Indication (FPI) support for improved fault management
 - Support for external medium voltage directional fault indication and for multifunction low voltage power quality metering
- Integrated wireless communication
 - Always on two-way communication based on cellular networks (GPRS, 3G, LTE)
 - Communication monitoring and automatic connection re-establishment
 - High level data security through internal VPN and Firewall
 - Support for Arctic Patrol centralized device management application
- Protocol converter
 - Conventional IEC-101 and Modbus serial devices can be connected in a reliable way to the modern TCP/IP based IEC-104 and Modbus TCP control systems
- Built-in battery charger with advanced battery control
 - Temperature compensated charging
 - Battery monitoring/testing (condition monitoring)
 - Deep discharge protection
- IEC-101 SCADA compliancy
 - IEC 60870-5-101 slave (including dial-up) to support the existing system installations
 - Possibility for future SCADA migration from IEC-101 to IEC-104 is supported as the operating mode is selected using the parameter settings
 - IEC-101 operation mode as unbalanced slave
- Heater control to limit the effects of ambient temperature variations such as condensation
- Robust aluminium casing design and easy DIN rail mounting

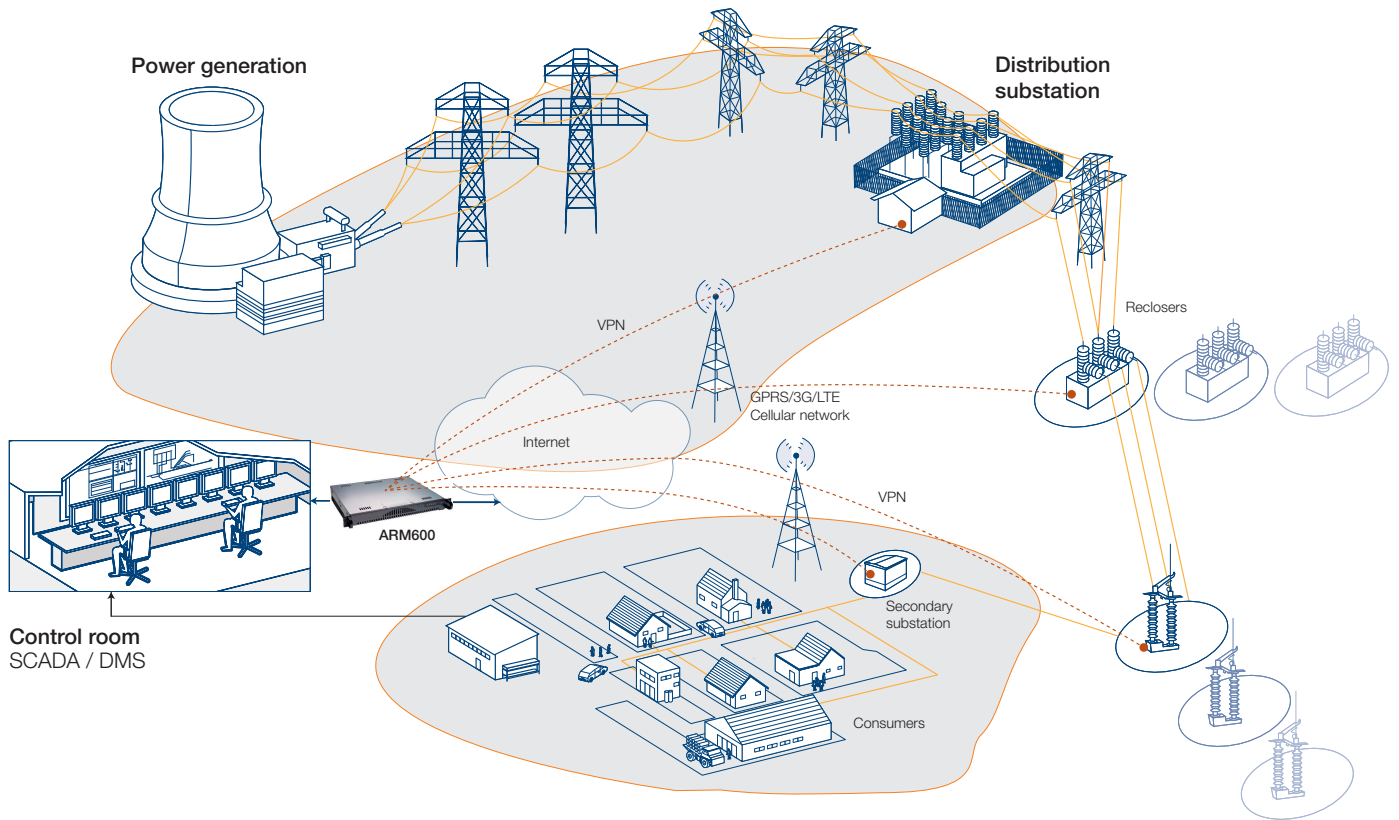

Figure 3. Communication solution in distribution automation overview

Application examples



Figure 4. Within the UEMC 50 the ARC600 unit is used for the remote control of a disconnecter. The motor operating device is placed in the same UEMC 50 enclosure as the other equipment.

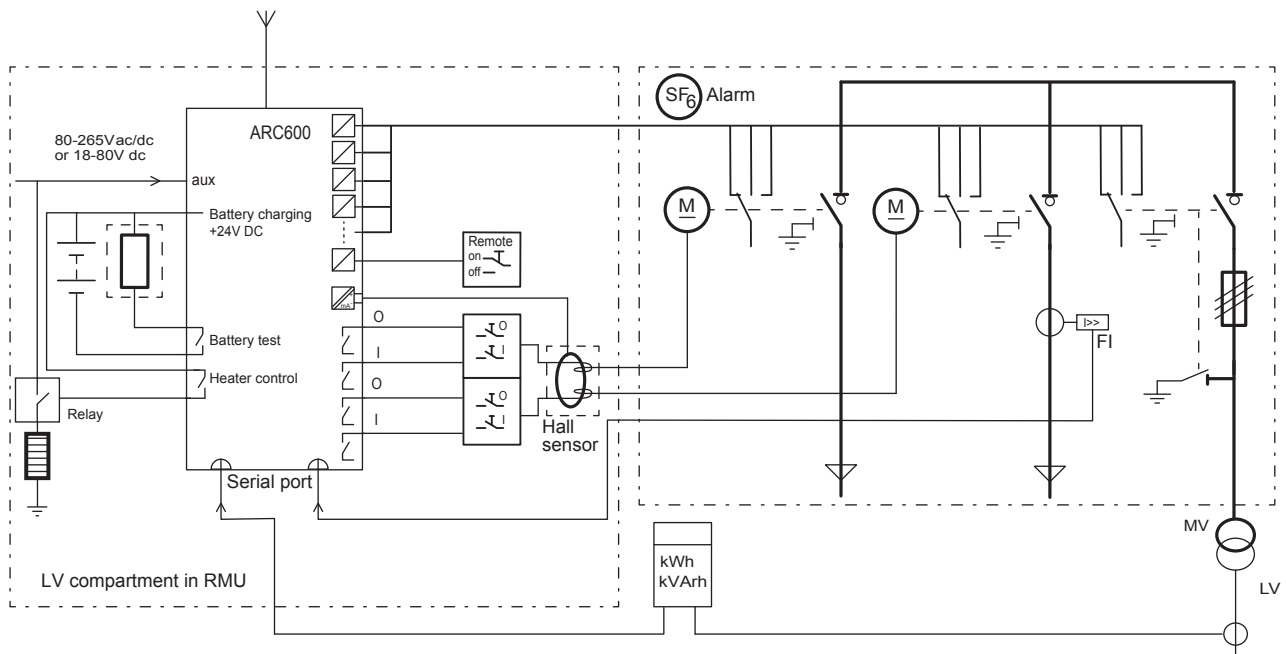

Figure 5. An ARC600 unit used for the remote control of a Ring Main Unit and fault indication

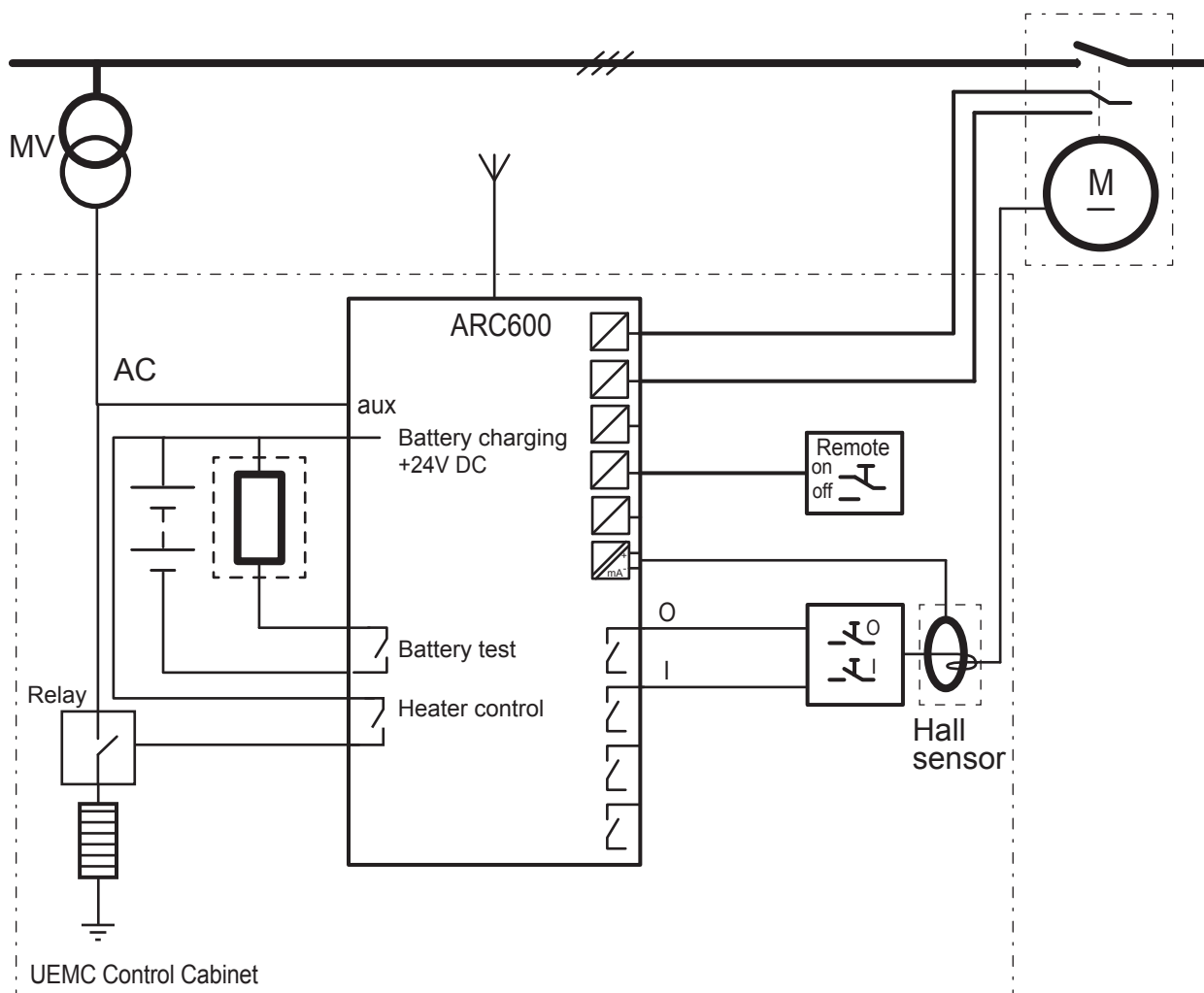

Figure 6. Within the UEMC control cabinet, the ARC600 unit is used for the remote control of a disconnecter. The motor operating device is fitted to the disconnecter.

4. Battery condition monitoring

Wireless Controller ARC600 is equipped with a condition monitoring based battery charger. This allows scheduled monitoring of the backup batteries inside the control cabinet which enables the optimization of lifetime and maintenance intervals of the backup batteries. The backup battery can be either manually or periodically tested by switching off the charger and switching on the external dummy load.

Manual testing can be initiated from a central control system via the IEC-104 protocol. Based on the current and voltage measurements taken from the battery, an assessment is made regarding the battery's condition and remaining operational capacity (in Ah). Based on these measurements of the battery's current and voltage levels, an IEC 60870-5-104 alarm event is then generated in the system.

ARC600 has also protection against complete battery discharge.

5. Motor overload protection

Wireless Controller ARC600 protects the disconnecter motor by using overcurrent detection. The current of the disconnecter motor is continuously measured and if the preset value is exceeded, the current supply to the motor is cut. The preset current value should be set so that the current supply to the motor is cut before the motor protection fuse opens the circuit. This leads to less site visits to reset the fuse. Typically, rust or ice might cause the disconnecter blades to get stuck in the closed position, resulting in either damage to the disconnecter motor due to overcurrent or operation of the protection fuse.

6. Physical interfaces

Wireless Controller ARC600 is equipped with numerous inputs and outputs to interface with the controllable substation equipment. ARC600 has 17 binary inputs, 10 binary outputs and 2 analog inputs. There are also two serial ports (RS-232, RS-485) and one LAN/WAN port for device connectivity.

Front panel LEDs

ARC600 is equipped with groups of LEDs indicating the complete operational status of the device. The LEDs are located on the front panel and are identified by the accompanying labels.

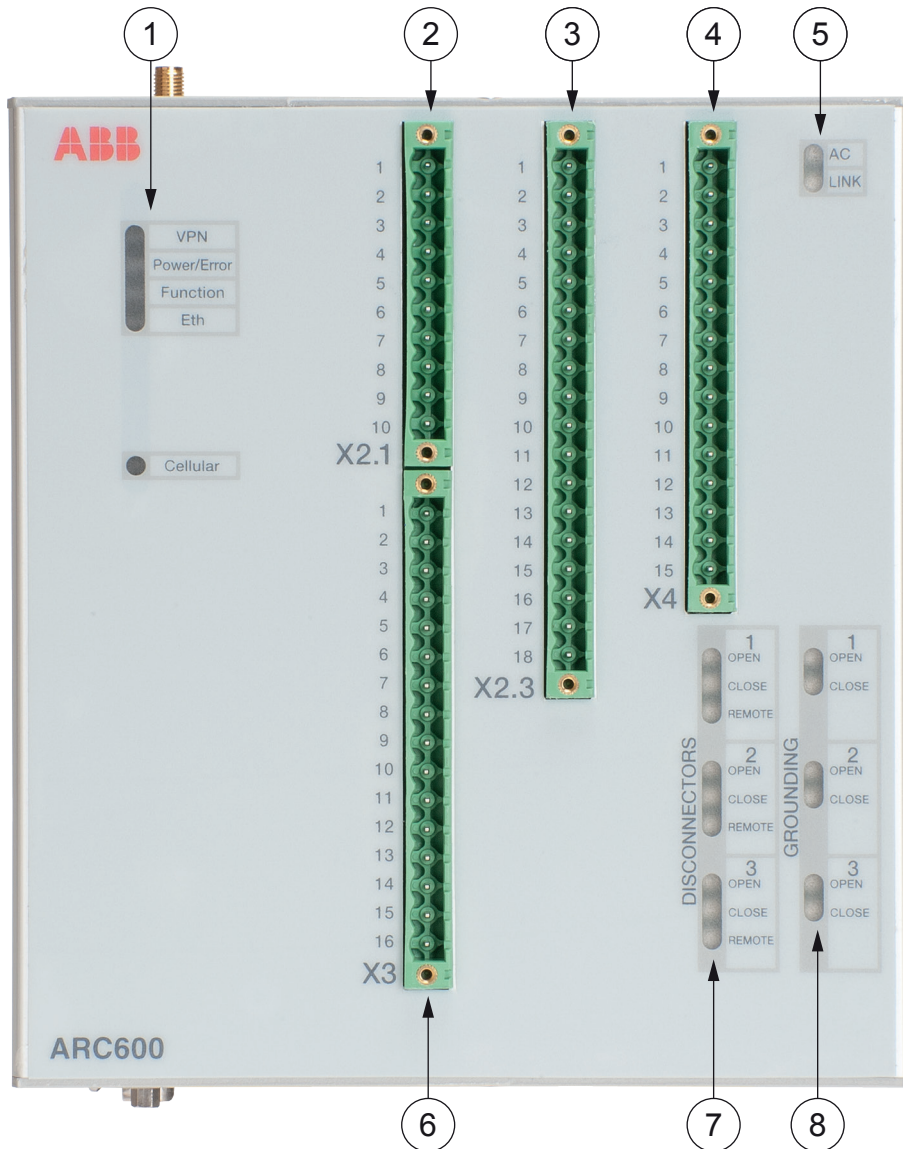

Figure 7. Front panel

- 1 System status LEDs
- 2 X2.1 connector
- 3 X2.3 connector
- 4 X4 connector
- 5 AC and LINK LEDs
- 6 X3 connector
- 7 Disconnector status LEDs
- 8 Grounding disconnector status LEDs

Table 1. Description of available LEDs

Label		State	Description
VPN		On	VPN connection is up
		Flashing	VPN connection is starting
		Off	VPN connection is disabled
Power/Error		On	Operating power is turned on
		Off	Operating power is turned off
Function		On	Device is starting
		Flashing	Device is operating normally
Eth		On	Ethernet link is up
		Flashing	Ethernet link is transferring data
		Off	Ethernet link is down
Cellular		Flashing	Cellular connection is starting or transferring data
		Off	Cellular connection is inactive
AC		On	Connected to AC power
		Off	Not connected to AC power
LINK		On	IEC 60870-5-104 control link to SCADA is active
		Off	IEC 60870-5-104 control link to SCADA is active
DISCONNECTORS 1...3	OPEN	On/Off	Open position indication for disconnecter
	CLOSE		Close position indication for disconnecter
	REMOTE	On	Remote control indication
		Off	Local control indication
GROUNDING 1...3	OPEN	On/Off	Open position indication for grounding disconnecter
	CLOSE		Close position indication for grounding disconnecter

Serial panel

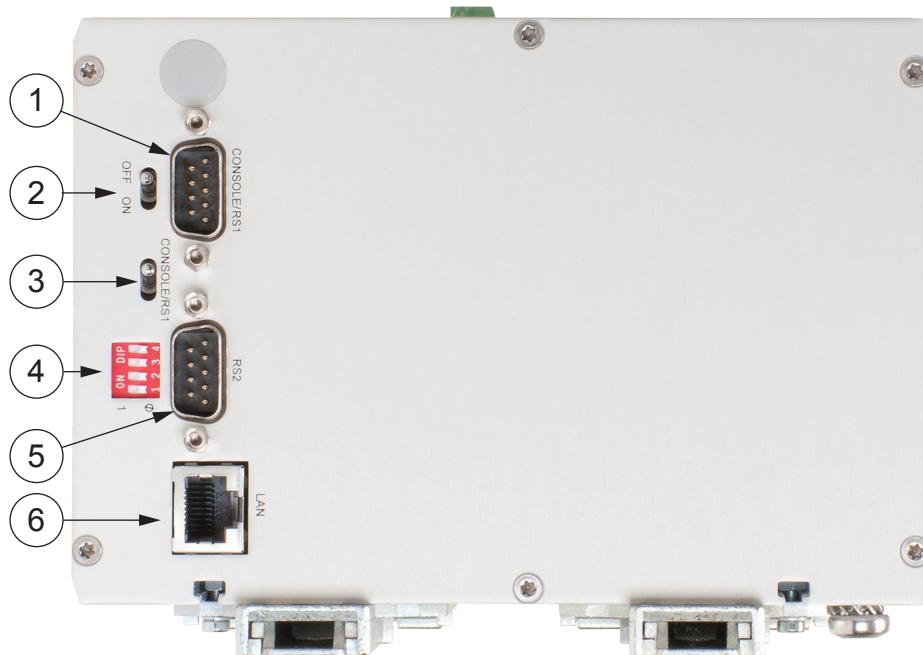

Figure 8. Serial panel

- 1 Console serial port (DIP switch selectable application or console port RS1)
- 2 Power switch
- 3 Serial console switch (RS1)
- 4 Serial port 2 hardware configuration DIP switches
- 5 Serial port 2
- 6 Ethernet connector

Antenna panel

ARC600 has a SIM card insertion slot with SIM card tray and SMA type antenna connector on the antenna panel.



Figure 9. Antenna panel

- 1 SIM card tray connector
- 2 SIM card tray release button
- 3 Antenna connector SMA (female)

7. Communication

Wireless Controller ARC600 provides a complete solution for monitoring and controlling field devices. A secure communication channel can be formed for remote serial (RS-232/RS-485) or Ethernet field devices over a GPRS, 3G or LTE connection. ARC600 makes it possible to have cost-effective communication networks over long distances at high data rates (up to 100 Mbps).

Several interfaces are available for field device connectivity: digital inputs and outputs, analog inputs, serial and Ethernet ports. Industrial protocols IEC-104, IEC-101 and Modbus TCP are supported for the SCADA connectivity. The inputs and outputs of ARC600 can be accessed and controlled with the IEC-104 and IEC-101 protocols.

With the Wireless Controller ARC600 protocol conversion feature, conventional IEC-101, Modbus RTU and Modbus TCP devices can be connected in a reliable way to modern TCP/IP based IEC-104 control systems.

Modbus to IEC-104 conversion

ARC600 provides support for generic Modbus RTU and Modbus TCP devices such as ABB's RIO600. In addition, support is also provided for the preselected Modbus parameters for Fault Passage Indicators (FPI). Currently, Horstmann Compass B and Kries IKI-50 are supported. ARC600 polls the fault indicator devices, connected to the serial port, using Modbus protocol and converts the values to IEC 60870-5-104. Up to four fault indicators can be connected to one device. IEC 60870-5-104 is used to communicate towards a SCADA via the Arctic M2M Gateway over the available customer chosen cellular data network.

IEC-101 to IEC-104 conversion

With ARC600, conventional IEC 60870-101 serial devices can be attached to a modern TCP/IP based IEC 60870-5-104

control system. This is enabled by the protocol conversion from IEC 60870-5-101 to IEC 60870-104. In this case, ARC600 (IEC-101 master) uses local synchronous data polling where it continuously sends requests and the IEC-101 device (IEC-101 slave) responds. In the direction of the control room, the communication protocol is IEC-104 and ARC600 can send events asynchronously as they arise while SCADA performs only slow-period background scans. Another advantage of the local protocol conversion is an advanced data acknowledgement mechanism. IEC-104 allows multiple packets, and multiple events in a single packet, to be acknowledged collectively and the packets can be buffered up to the time of acknowledgement from SCADA.

Modbus RTU to Modbus conversion

Modbus field devices use usually serial mode (RTU or ASCII) protocol while the SCADA communication uses TCP/IP based Modbus TCP protocol. The Modbus user community has defined the functionality for required protocol integration, that is, how the Modbus RTU devices can talk to the Modbus TCP SCADA system. This functionality is a protocol conversion and it is implemented in ARC600. Many industrial devices like PLCs and RTUs support RS-485 Modbus RTU mode. In RS-485 mode, ARC600 can integrate unlimited number of serial slaves to TCP/IP network (SCADA).

ARC600 has two application serial ports. Serial port 1 is configurable to either console or data mode and it supports only RS-232, while serial port 2 is configurable to multiple serial modes (RS-232/RS-422/RS-485). Serial port connectors are 9-pin D-sub (male) connectors. More information is available in the Technical data section of this product guide or technical manual available at www.abb.com/substationautomation.

8. Technical data

Table 2. Dimensions

Description	Value
Height × Width × Depth	175 × 160 × 108 mm
Weight	2.4 kg
Protection class	IP30

Table 3. Hardware

Description	Value		
Processor environment	Processor	32 bit RISC	
	Memory	128 MB Flash 128 MB RAM	
Other	Sensor	Temperature	
	Internal clock	Real time	
Power	Power supply	90...264 V AC or 85...200 V DC 20...30 V DC (external battery)	
		Frequency range	45...65 Hz
	Input current, 100% load, 230 V AC	0.8 A	
	Efficiency, typical (230 V AC, 100% load)	>83%	
	Isolation	Input/ground	1500 V AC RMS 50 Hz 1 min
		Output	3000 V AC RMS 50 Hz 1 min
		Output/ground	500 V DC
	Inrush current 25°C, 230 V AC	<25 A <5 ms	
	Input fuse	T3.15 A high breaking	
	Power consumption	10 W typical (when not charging battery), 60 W (full charging)	
Overvoltage transient protection	VDR 275 V AC 72 J		
Holdup time (230 V, 100% load)	>50 ms		
Casing	Aluminium shell		
Approvals	CE		
Environmental conditions	Temperature range	-30...+55°C (non condensing) -40...+70°C (storage)	
		Relative humidity	5...85% RH

Table 4. Battery recommendations

Description	Yasa NP 17-12	Yasa NPL 24-12
Rated voltage	12 V	12 V
Capacity	17 Ah	24 Ah
Weight	6.1 kg	9 kg
Size (L × W × H)	181 × 76 × 167 mm	166 × 175 × 125 mm

Table 5. Supply for external devices and input circuits (X2.1 pin 6)

Description	Value
Output voltage	21...29 V
Output current	1 A continuous, 3 A peak
Output overvoltage protection level	30.5 V

Table 6. Temperature-compensated charger for batteries

Description	Value
Rated charging voltage	27.4 V at 20°C
Output power	60 W
Fuse	4 A
Temperature compensation	-40 mV/°C
Output overvoltage protection level	30.5 V

Table 7. Supported protocols

Master protocol	Slave protocol
IEC 60870-5-104	IEC 60870-5-101
IEC 60870-5-104	Modbus TCP
IEC 60870-5-104	Modbus RTU/ASCII
IEC 60870-5-104	Modbus (RTU) profile for Horstmann Compass B
IEC 60870-5-104	Modbus (RTU) profile for Kries IKI-50
IEC 60870-5-101	Modbus RTU
IEC 60870-5-101	Modbus TCP
IEC 60870-5-101	Modbus (RTU) profile for Horstmann Compass B
IEC 60870-5-101	Modbus (RTU) profile for Kries IKI-50
Modbus TCP	Modbus RTU
TCP/IP	Serial gateway - serial port data stream (such as DNP3)

Table 8. Supported protocols for I/O controlling

Master protocol
IEC 60870-5-104
IEC 60870-5-101

Wireless Controller	1MRS758465 D
ARC600	
Product version: 3.4.7	

Table 9. Default I/O configuration

Description		Value
Digital inputs (0...60 V DC, >18 V DC detected as 1)	Digital inputs for the disconnecter status control <ul style="list-style-type: none"> • Disconnecter 1: Open/closed, local/remote use, grounding open/closed – 5 pcs • Disconnecter 2: Open/closed, local/remote use, grounding open/closed – 5 pcs • Disconnecter 3: Open/closed, local/remote use, grounding open/closed – 5 pcs 	15
	Extra general purpose digital inputs reserved for other use	2
	Total number of digital inputs	17
Digital outputs (1 A/30 V DC continuous carry)	Digital outputs for the disconnecter open/close command <ul style="list-style-type: none"> • Disconnecter 1: Open/close – 2 pcs • Disconnecter 2: Open/close – 2 pcs • Disconnecter 3: Open/close – 2 pcs 	6
	Digital output for the load cut (motor overload protection)	1
	Digital output for the test load of the battery test (test load)	1
	Digital output for the external heater	1
	Extra general purpose digital output reserved for other use	1
	Total number of digital outputs	10
	Analog inputs (-5...+5 V measurement, ± 300 mV for -10...+55°C, 0 V...+5 V)	Load measurement (DC motor load current)
Extra reserved for other use		1
Total number of analog inputs		2

Table 10. I/O specifications

Description		Value
Digital inputs	Number of digital inputs	17
	Operating range	18...60 V DC (>18 V DC detected as 1)
	Current drain	3.5...12.5 mA
	Power consumption/input	<0.8 W
	Input polarity	bipolar
	Isolation	3 kV
Digital outputs	Number of digital outputs	10
	Output pin rated voltage	24 VDC
	Continuous carry 30 VDC	1 A

Table 11. Network interfaces

Description		Value	
Ethernet ports	Ethernet/LAN	10/100 Base-T. Shielded RJ-45	
		1.5 kV isolation transformer	
		Ethernet IEEE 802-3, 802-2	
Serial ports	Serial 1/Console	RS-232 DTE	
		Male DB-9 connector	
		IEC 60870-5-101 protocol support	
		Full serial and modem signals	
		300...460 800 bps	
		Data bits: 7 or 8	
		Stop bits: 1 or 2	
		Parity: None, Even, Odd	
		Flow control: None, RTS/CTS	
		Protection: 15 kV ESD and short circuit	
		Console: RS-232, 19200 bps, 8 data bits, 1 stop bit, no parity (8N1)	
		Serial 2	RS-232 DTE, RS-422, RS-485 (selectable)
			Male DB-9 connector
	IEC 60870-5-101 protocol support		
	Full serial and modem signals		
	300...460 800 bps		
	Data bits: 7 or 8		
	Stop bits: 1 or 2		
	Parity: None, Even, Odd		
	Flow control: None, RTS/CTS		
Protection: 15 kV ESD and short circuit			

Table 12. Wireless network interfaces (WAN)

Product	Air interface	Frequency	Maximum data rate
	GPRS/EDGE	1900/1800/900/850 MHz	85.2 Kbps/236.8 kbps
	WCDMA/HSPA+	2100/1900/900/850 MHz	21 Mbit/s
	LTE	2600 (band 7)/2100 (band 1)/1800 (band 3)/900 (band 8)/800 (band 20) MHz	100 Mbit/s

Table 13. Antenna connectors

Description	Type
Antenna connector	SMA (female, 50 Ω)

Wireless Controller	1MRS758465 D
ARC600	
Product version: 3.4.7	

Table 14. Electromagnetic compatibility tests

Description		Reference
Emission tests according to the test specification IEC 61850-3 (Edition 2.0 2013-12)	Radiated disturbance	CISPR 16-2-3
	Conducted disturbance	CISPR 16-2-1
Immunity tests according to the test specification IEC 61850-3 (Edition 2.0 2013-12)	Electrostatic discharge (ESD)	EN 61000-4-2 (2008-12)
	Radiated radiofrequency electromagnetic field	EN 61000-4-3 (2006-02)
	Electrical fast transient (EFT)	EN 61000-4-4 (2012-04)
	Surge	EN 61000-4-5 (2005-11)
	Conducted radiofrequency electromagnetic field	EN 61000-4-6 (2008-10)
	Power frequency magnetic field	EN 61000-4-8 (2009-09)
	Voltage dips	EN 61000-4-11 (2004-03)

Table 15. RoHS and REACH compliancy

Description	Reference
Directive	RoHS directive 2002/95/EC
	REACH directive 2006/1907/EC

9. Mounting

The devices have been equipped with mounting arrangements that are specially designed to enable DIN rail mounting inside the control cabinets. A set of DIN rail mounting clips is included with the devices.

The order number consists of a string of codes generated from the device's hardware and software modules. Use ABB Library to access the selection and ordering information and to generate the order number.

10. Ordering data

The product label contains basic information about the unit such as product name, serial number and Ethernet MAC address.

The product label is found on top of the device.

Table 16. Ordering data

Description	ARC600A2324NA
Radio IF	LTE
Data speed max	100 Mbps

11. Accessories and ordering data

Certain equipment accessories can be attached to the devices to increase the flexibility and functionality of the devices according to the application requirements within the network. More information regarding these additions should be requested and discussed when planning and ordering the equipment from ABB Distribution Automation. Replacement

parts for the devices are also available from ABB. This includes all external parts or components of the sold device that could have been damaged or lost. ABB does not supply internal components or parts. The external replacement parts, on the other hand, can be ordered from ABB After-Sales Service via [Parts-OnLine](#).

Table 17. Accessories

Description	Order code
Test load resistor	2RCA028171
NTC resistor	2RCA028226
Hall sensor	2RCA028227
3G puck antenna (SMA male)	2RCA037240
DIN rail mounting kit (metal)	2RCA037241
I/O connector set	2RCA037242
Power cord (European plug)	2RCA037647
SMA(m)/FME(m) adapter ¹⁾	2RCA037659
Laird LTE antenna 700...2700 MHz (SMA male)	2RCA037660

1) Needed for single SIM Arctic products, if the third party antenna's connector type is FME female

More information is also available from aftersales.relays@fi.abb.com.

12. Tools

The devices can be configured using a graphical user interface via a Web based browser. A conventional console interface is

also provided. Software updates or configuration adjustments for the devices can be made remotely by uploads over the network from the central control center.

13. Terminal diagrams

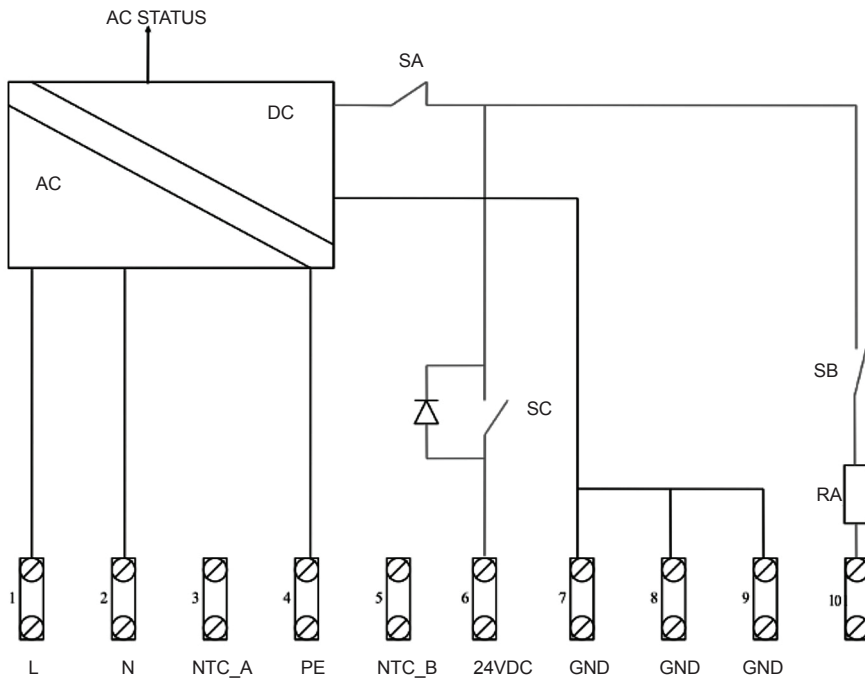

Figure 10. X2.1 connector schematics

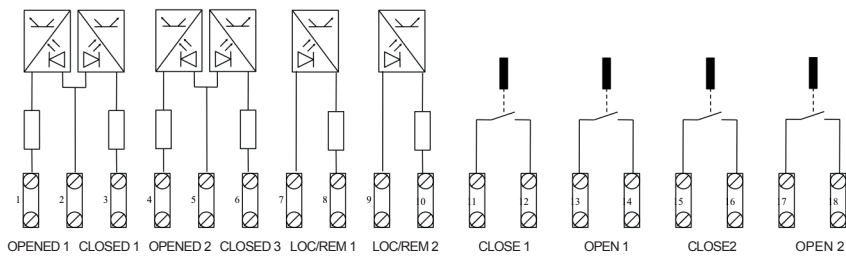

Figure 11. X2.3 connector schematics

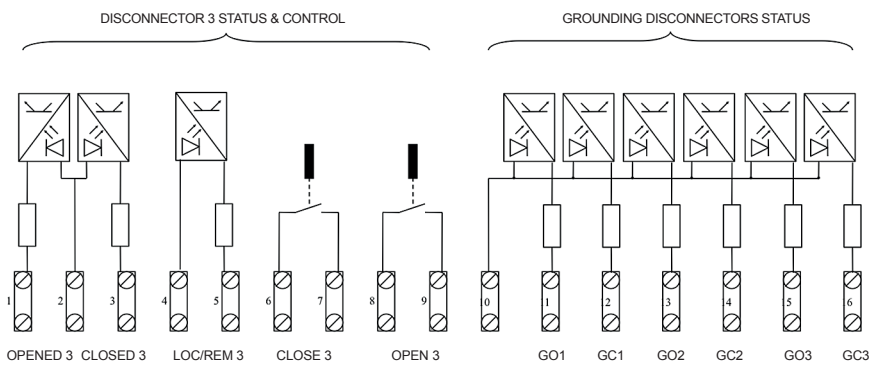

Figure 12. X3 connector schematics

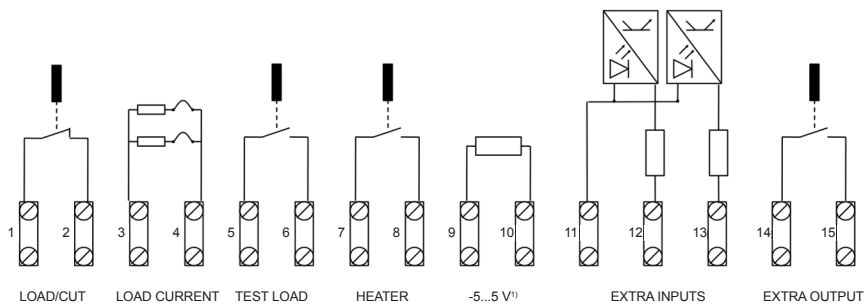

Figure 13. X4 connector schematics

¹⁾ Can be used as a 4...20 mA input using external resistor

14. References

The www.abb.com/substationautomation portal provides information on the entire range of distribution automation products and services.

Wireless Controller	1MRS758465 D
ARC600	
Product version: 3.4.7	

15. Document revision history

Document revision/date	Product version	History
A/2015-12-18	A	First release
B/2017-06-07	3.3	Content updated
C/2017-09-22	3.4	Content updated to correspond to the product version
D/2019-04-24	3.4.7	Content updated to correspond to the product version



ABB Distribution Solutions
Distribution Automation

P.O. Box 699

FI-65101 VAASA, Finland

Phone +358 10 22 11

www.abb.com/mediumvoltage

www.abb.com/substationautomation