

PRODUCT GUIDE

RED615

Line differential protection and control



Table of contents

004	Description
004	Standard configurations
010	Protection functions
010	Application
013	Supported ABB solutions
014	Control
015	Measurements
015	Power quality
015	Fault location
015	Disturbance recorder
016	Event log
016	Recorded data
016	Condition monitoring
017	Trip-circuit supervision
017	Self-supervision
017	Current circuit supervision
017	Protection, communication and supervision

Table of contents

018	Access control Inputs and outputs
018	Inputs and outputs
019-023	Station communication
024-053	Technical data
054	Local HMI
055	Mounting methods
055	Relay case and plug-in unit
055	Selection and ordering data
056	Accesories and ordering data
056	Tools
057	Cyber security
058-059	Terminal diagrams
060	Certificates
060	References
061-062	Functions, codes, and symbols
062	Document revision history

RED615

Line differential protection and control

1. Description

RED615 is a phase-segregated two-end line differential protection and control relay designed for utility and industrial power systems, including radial, looped and meshed distribution networks with or without distributed power generation. RED615 is also designed for the protection of line differential applications with a transformer within the protection zone. RED615 relays communicate between substations over a fiber optic link or a galvanic pilot wire connection. RED615 is a member of ABB's Relion® product family and part of its 615 protection and control product series. The 615 series relays are characterized by their compactness and withdrawable-unit design. Re-engineered from the ground up, the 615 series has been guided by the IEC 61850 standard for communication and interoperability of substation automation equipment.

The relay provides unit type main protection for overhead lines and cable feeders in distribution networks. The relay also features current-based protection functions for remote backup for downstream protection relays and local back-up for the line differential main protection. Standard configurations D and E include directional overcurrent and voltage based protection functions.

The relay is adapted for the protection of overhead line and cable feeders in isolated neutral, resistance grounded, compensated (impedance grounded)

and solidly grounded networks. Once the relay has been given the application specific settings, it can directly be put into service.

The 615 series relays support a range of communication protocols including IEC 61850 with Edition 2 support, process bus according to IEC 61850-9-2 LE, Modbus® and DNP3.

2. Standard configurations

RED615 is available in two alternative standard configurations. The standard signal configuration can be altered by means of the signal matrix or the graphical application functionality of the Protection and Control Relay Manager PCM600. Further, the application configuration functionality of PCM600 supports the creation of multi-layer logic functions utilizing various logical elements including timers and flip-flops. By combining protection functions with logic function blocks the relay configuration can be adapted to user specific application requirements.

The relay is delivered from the factory with default connections described in the functional diagrams for binary inputs, binary outputs, function-to-function connections and alarm LEDs. Some of the supported functions in RED615 must be added with the Application Configuration tool to be available in the Signal Matrix tool and in the relay. The positive measuring direction of directional protection functions is towards the outgoing feeder.

Figure 1. Functionality overview for standard configuration D

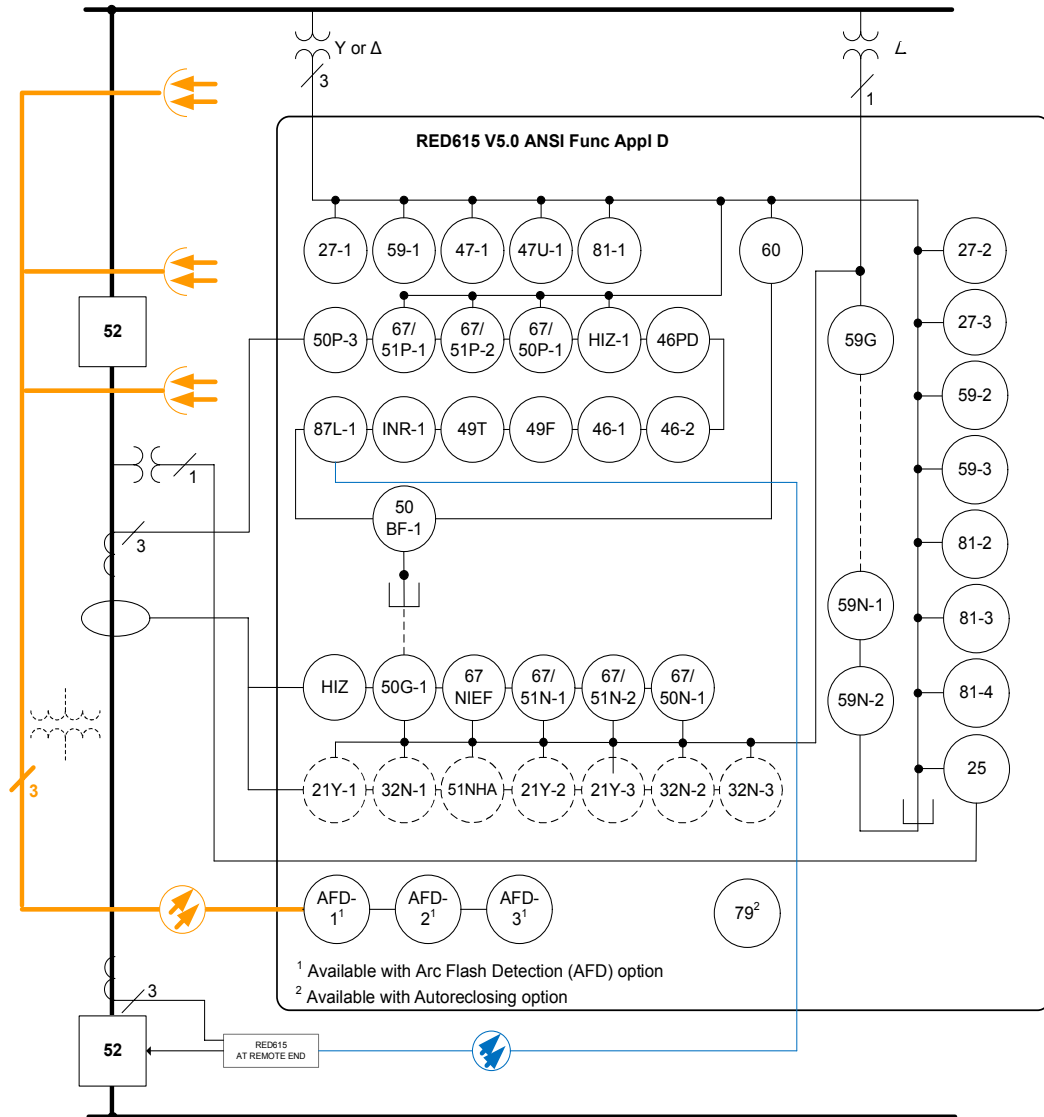

Figure 2. Functionality overview for standard configuration E

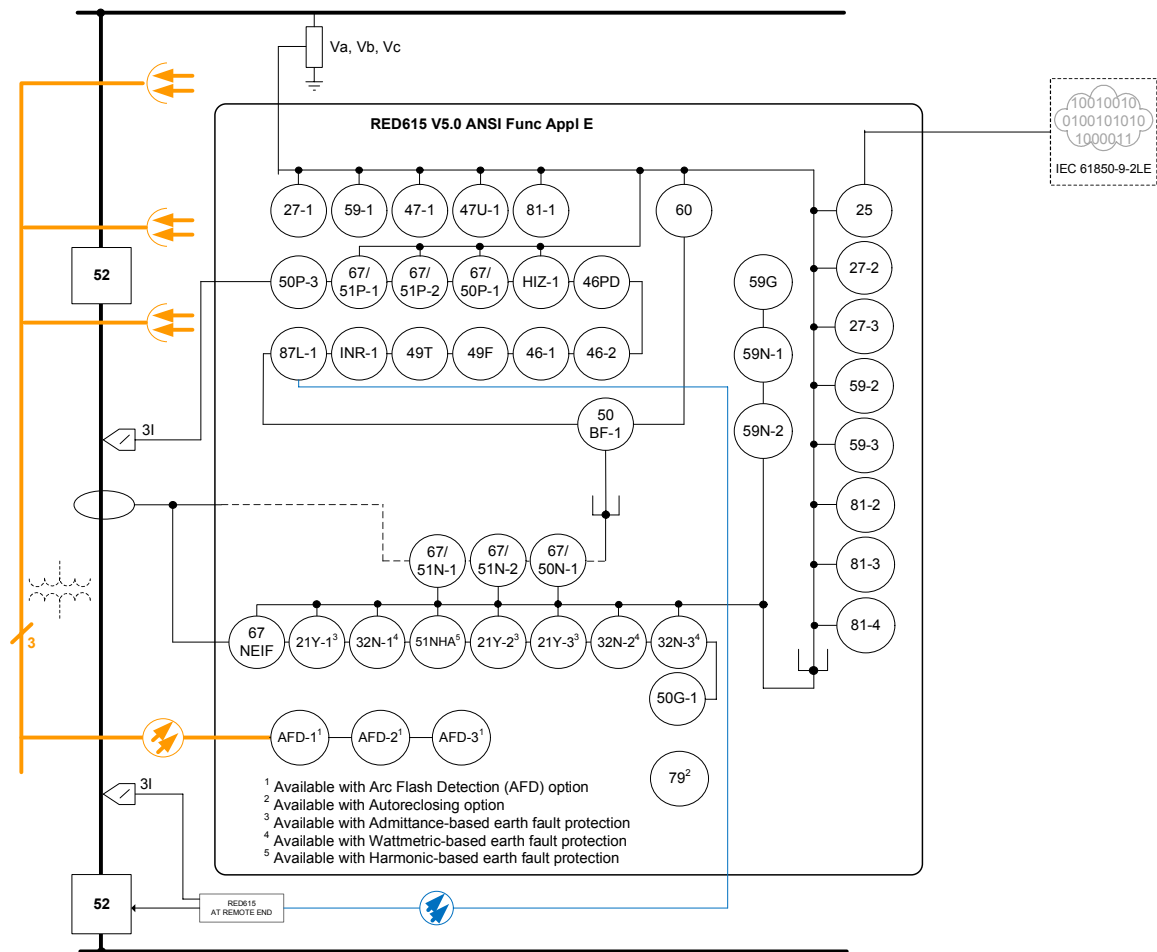

Table 1. Standard configurations

Description	Std. conf.
Line differential protection with directional O/C, directional E/F, voltage & frequency based protection & measurements, synchro-check and CB condition monitoring (RTD option, optional power quality and fault locator)	D
Line differential protection with directional O/C, directional E/F, voltage and frequency based protection & measurements and CB condition monitoring (Sensor inputs, optional power quality, fault locator and synchro-check with IEC61850-9-2LE)	E

Table 2. Supported functions

Function	IEC 61850	ANSI	C	D
Protection				
Three-phase non-directional overcurrent protection, instantaneous stage	PHIPTOC	50P-3	1	1
Three-phase directional overcurrent protection, low stage	DPHLPDOC	67/51P	2	2
Three-phase directional overcurrent protection, high stage	DPHHPDOC	67/50P	1	1
Non-directional ground-fault protection, high stage	EFHPTOC	50G	1 ⁴⁾	1 ⁴⁾
Directional ground-fault protection, low stage	DEFLPDEF	67/51N	2 ^{5) 9)}	2 ^{5) 10)}
Directional ground-fault protection, high stage	DEFHPDEF	67/50N		1 ^{5) 10)}
Admittance-based ground-fault protection ¹⁾	EFPADM	21YN	(3) ^{1) 4) 9)}	(3) ^{1) 4) 11)}
Wattmetric-based ground-fault protection ¹⁾	WPWDE	32N	(3) ^{1) 4) 9)}	(3) ^{1) 4) 11)}
Transient/intermittent ground-fault protection	INTRPTEF	67NIEF	1 ^{9) 15)}	1 ^{11) 15)}
Harmonics-based ground-fault protection ¹⁾	HAEFPTOC	51NHA	(1) ^{1) 15) 19)}	(1) ^{1) 15) 19)}
Negative-sequence overcurrent protection	NSPTOC	46	2	2
Phase discontinuity protection	PDNSPTOC	46PD	1	1
			1 ⁹⁾	1 ⁹⁾
			1 ¹²⁾	1 ¹²⁾
Residual overvoltage protection	ROVPTOV	59G/59N	1 ^{12) 19)}	1 ^{12) 19)}
			2	2
Three-phase undervoltage protection	PHPTUV	27	1 ¹⁹⁾	1 ¹⁹⁾
			2	2
Three-phase overvoltage protection	PHPTOV	59	1 ¹⁹⁾	1 ¹⁹⁾
Positive-sequence undervoltage protection	PSPTUV	47U	1	1
Negative-sequence overvoltage protection	NSPTOV	47	1	1
Frequency protection	FRPFRQ	81	4 ¹⁹⁾	4 ¹⁹⁾
Three-phase thermal protection for feeders, cables and distribution transformers	T1PTTR	49F	1	1
Three-phase thermal protection for feeders, cables and distribution transformers	T2PTTR	49T	1	1
Binary signal transfer	BSTGGIO	BST	1	1
Circuit breaker failure protection	CCBRBRF	50BF	1	1
Three-phase inrush detector	INRPHAR	INR	1	1
Switch onto fault	CBPSOF	SOTF	1 ^{19)*}	1 ^{19)*}
Master trip	TRPPTRC	86/94	2	2
Multipurpose protection 2)	MAPGAPC	MAP	18 ¹⁹⁾	18 ¹⁹⁾
Fault locator	SCEFRFLO	21FL	(1) ¹⁹⁾	(1) ¹⁹⁾
Line differential protection with in-zone power transformer	LNPLDF	87L	1	1
High-impedance fault detection	PHIZ	HIZ	1 ¹⁹⁾	
Power quality				
Current total demand distortion	CMHAI	PQI	(1) ^{17) 19)}	(1) ^{17) 19)}
Voltage total harmonic distortion	VMHAI	PQVPH	(1) ^{17) 19)}	(1) ^{17) 19)}
Voltage variation	PHQVVR	PQSS	(1) ^{17) 19)}	(1) ^{17) 19)}
Voltage unbalance	VSQVUB	PQVUB	(1) ^{17) 19)}	(1) ^{17) 19)}
Control				
Circuit breaker control	CBXCBR	52	1	1
Disconnecter control	DCXSWI	29DS	2 ¹⁹⁾	2 ¹⁹⁾
Grounding switch control	ESXSWI	29GS	1 ¹⁹⁾	1 ¹⁹⁾
			1 ¹⁹⁾	1 ¹⁹⁾
Disconnecter position indication	DCSXSWI	52-TOC, 29DS	2 ¹⁹⁾	2 ¹⁹⁾
Grounding switch indication	ESSXSWI	29GS	2 ¹⁹⁾	2 ¹⁹⁾
Autoreclosing	DARREC	79	(1)	(1)
Synchronism and energizing check	SECRSYN	25	1 ¹⁹⁾	(1) ^{26) 19)}
Condition monitoring and supervision				

Table 2. Supported functions, continued

Function	IEC 61850	ANSI	C	D
Condition monitoring and supervision				
Circuit breaker condition monitoring	SSCBR	52CM	1	1
Trip circuit supervision	TCSSCBR	TCM	2	2
Current circuit supervision	CCSPVC	CCM	1	1
Fuse failure supervision	SEQSPVC	60	1	1
Protection communication supervision	PCSITPC	PCS	1	1
Runtime counter for machines and devices	MDSOPT	OPTM	1 ¹⁹⁾	1 ¹⁹⁾
Measurement				
Load profile record	LDPRLRC	LOADPROF	1	1
Three-phase current measurement	CMMXU	IA, IB, IC	1	1
Sequence current measurement	CSMSQI	I1, I2, I0	1	1
Residual current measurement	RESCMMXU	IG	1	1
Three-phase voltage measurement	VMMXU	VA, VB, VC	2	1 (1) ^{19) 26)}
Residual voltage measurement	RESVMMXU	VG	1	
Sequence voltage measurement	VSMSQI	V1, V2, V0	1	1
Single-phase power and energy measurement	SPEMMXU	SP, SE	1	1
Three-phase power and energy measurement	PEMMXU	P, E	1	1
RTD/mA measurement ^{EX)}	XRGGIO130	X130 (RTD)	(1)	
Frequency measurement	FMMXU	f	1	1
IEC 61850-9-2 LE sampled value sending ^{23), 26)}	SMVSENDER	SMVSENDER	(1)	(1)
IEC 61850-9-2 LE sampled value receiving (voltage sharing) ^{23), 26)}	SMVRCV	SMVRECEIVER	(1)	(1)
Other				
Minimum pulse timer (2 pcs)	TPGAPC	62TP	2 2 ¹⁹⁾ ¹¹⁾	3 ¹⁹⁾ 1
Minimum pulse timer (2 pcs, second resolution)	TPSGAPC	62TPS	1 ¹⁹⁾	1 ¹⁹⁾
Minimum pulse timer (2 pcs, minute resolution)	TPMGAPC	62TPM	1 ¹⁹⁾	1 ¹⁹⁾
Pulse timer (8 pcs)	PTGAPC	62PT	2 ¹⁹⁾	2 ¹⁹⁾
Time delay off (8 pcs)	TOFGAPC	62TOF	2 2 ¹⁹⁾	2 2 ¹⁹⁾
Time delay on (8 pcs)	TONGAPC	62TON	2 2 ¹⁹⁾	2 2 ¹⁹⁾
Set-reset (8 pcs)	SRGAPC	SR	4 ¹⁹⁾	4 ¹⁹⁾
Move (8 pcs)	MVGAPC	MV	2 ¹⁹⁾	2 ¹⁹⁾
Generic control point (16 pcs)	SPCGAPC	SPC	2 ¹⁹⁾	2 ¹⁹⁾
Analog value scaling (4 pcs) ¹⁾	SCA4GAPC	SCA4	4 ¹⁹⁾	4 ¹⁹⁾
Integer value move (4 pcs) ¹⁾	MVI4GAPC	MVI4	1 ¹⁹⁾	1 ¹⁹⁾
Generic up-down counters	UDFCNT	CTR	4 ¹⁹⁾	4 ¹⁹⁾

() = optional

1) One of the following can be ordered as an option; Admittance based E/F, Wattmetric based E/F or Harmonics based E/F. The option is an addition to the existing E/F of the original configuration. The optional E/F has also a predefined configuration in the relay. The optional E/F can be set on or off

2) Multi-purpose protection is used for, for example, RTD/mA based protection, or Analogue Goose

3) Light only

4) Io selectable by parameter, Io measured as default

5) Io selectable by parameter, Io calculated as default

6) Io calculated is always used

7) IoB calculated is always used

8) IoB calculated and 3IB are always used

9) Uo selectable by parameter, Uo measured as default

10) Uo calculated and negative sequence voltage selectable by parameter, Uo calculated as default

11) Uo calculated is always used

12) Uo measured is always used

13) IoB measured is always used

- 14) IoB measured and 3IB are always used
- 15) Io measured is always used
- 16) IoB selectable by parameter, IoB measured as default
- 17) Power quality option includes Current total demand distortion, Voltage total harmonic distortion and Voltage variation
- 18) Available in IED and SMT but not connected to anything in logic
- 19) Must be added with ACT to be available in SMT and in protection relay
- 20) Uob measured is always used for unbalance protection with ungrounded single Y connected capacitor bank.
- 21) The lumb measurements values will be taken from this block and put in Measurment view.
- 22) Master Trip included and connected to corresponding HSO in the configuration only when BIO0007 module is used. If additionally the ARC option is selected, then ARCSARC is connected in the configuration to the corresponding Master Trip input.
- 23) Only available with COM0031-0037
- 24) Power quality option includes only Current total demand distortion
- 25) Unbalance voltage measurement for capacitor bank for REV615
- 26) Only available with IEC 61850-9-2
- LV) The function block is to be used on the low voltage side in the application
- HV) The function block is to be used on the high voltage side in the application
- NT) The function block is to be used on the neutral side in the application
- TR) The function block is to be used on the terminal side in the application
- BS) The function block is to be used on the bus side in the application
- EX) This function to be excluded from the Integration Test Data generation

3. Protection functions

The relay offers two-stage phase-segregated line differential protection, phase overcurrent protection, negative-sequence overcurrent protection and circuit breaker failure protection. Depending on the chosen standard configuration, the basic functionality can be extended by thermal overload protection, non-directional or directional overcurrent protection, directional or non-directional ground-fault protection, sensitive ground-fault protection, phase discontinuity protection, transient/intermittent ground-fault protection, residual overvoltage protection, phase-voltage and frequency based protection and three-pole multi-shot auto-reclosing functions for overhead line feeders. For standard configurations B, D and E, admittance-based, watt-metric-based or harmonics-based ground-fault protection is offered as an option in addition to the directional ground-fault protection.

The line differential protection function includes a stabilized low stage and an instantaneous high stage. The stabilized low stage provides sensitive differential protection and remains stable during, for example, current transformer saturation conditions. The low-stage operation can be restrained using second harmonic detection if an out-of-zone power transformer is to be energized. The instantaneous high stage offers less sensitive differential protection but enables fast operation during high fault currents. If there is an in-zone transformer in the protection zone, the vector group is automatically compensated based on the winding types and clock number setting values. The operating time characteristic for the low stage can be set to definite time or inverse definite time mode. The direct intertrip function ensures that both ends are always simultaneously tripped, independent of the fault current contribution.

4. Application

RED615 can be used in a variety of applications requiring an absolutely selective unit type protection system. The zone-of protection of a line differential protection system is the feeder section defined by the location of the current transformers in the local and the remote substation. RED615 can also be used for line differential protection if there is an in-zone transformer in the protected feeder section.

Combining horizontal GOOSE communication over a station bus and binary signal transfer over the protection communication link offers new

application possibilities beyond traditional line differential protection. One interesting application based on inter-substation signal transfer is loss of mains (LOM) protection in networks with distributed generation. The performance of the combination of binary signal transfer and horizontal GOOSE communication performance as to speed, selectivity and reliability are hard to match with conventional loss-of-mains protection.

RED615 is the ideal relay for the protection of feeders in network configurations containing closed loops. Under normal operating conditions the feeder loop is closed. The aim of the closed loop is to secure the availability of power for the end users. As a result of the closed loop configuration, any fault spot in the system will be fed with fault current from two directions. Using plain overcurrent protection, either directional or non-directional, it is difficult to obtain fast and selective short circuit protection. With RED615 line differential protection relays the faulty part of the network can be selectively isolated, thus securing power distribution to the healthy part of the network.

The standard configuration E includes one conventional residual current (I_o) input and three combi-sensor inputs for phase currents and phase voltages. The connection of the three combi-sensors is made with RJ-45 type of connectors.

Sensors offer certain benefits compared to conventional current and voltage instrument transformers. For example, current sensors do not saturate at high currents, they consume less energy and they weigh less. In voltage sensors the risk of ferro-resonance is eliminated. The sensor inputs also enable the use of the relay in compact medium voltage switchgears, such as ABB's ReliaGear ND Digital, Advance Digital, and SafeGear Digital, with limited space for conventional measuring transformers, thus requiring the use of sensor technology. Further, the adapters also enable the use of sensors with Twin-BNC connectors.

Under certain operational circumstances, such as maintenance of primary equipment or substation extension projects there will be a need to interconnect network parts, which normally are separated. To avoid major re-parameterization of the protection devices of the network when the network topology is changed, line differential protection relays can be used to obtain absolutely selective feeder protection in looped networks.

Figure 3. Line differential protection of a feeder using the standard configurations D

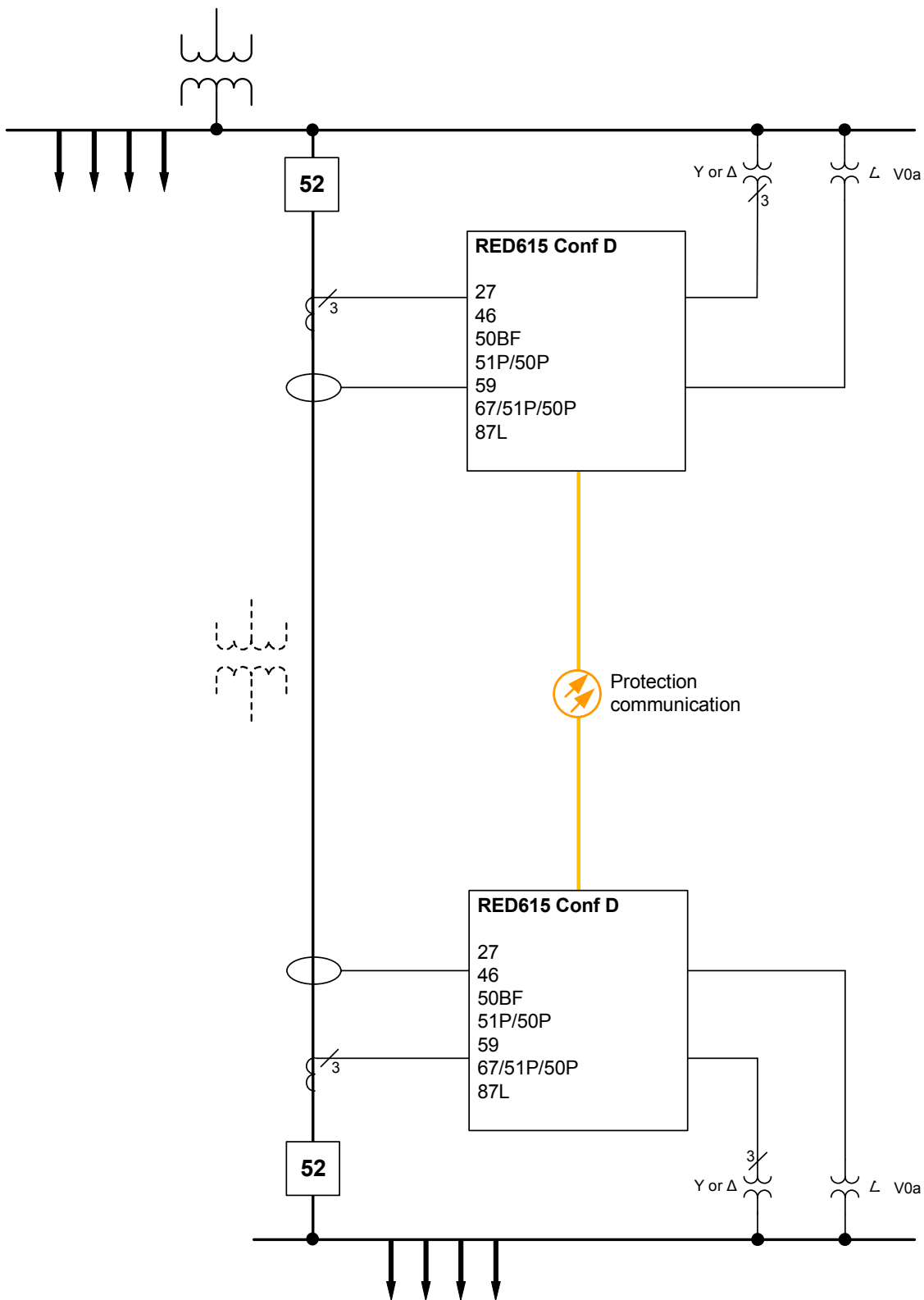

Figure 3 illustrates line differential protection for an interconnecting feeder between two primary distribution substations using standard configuration D. Additionally, protection is offered for a in-zone power transformer, when available and located in the protection zone.

Protection is offered for an in-zone power transformer, when available and located in the protection zone.

Figure 4. Line differential protection of a feeder using the standard configuration E

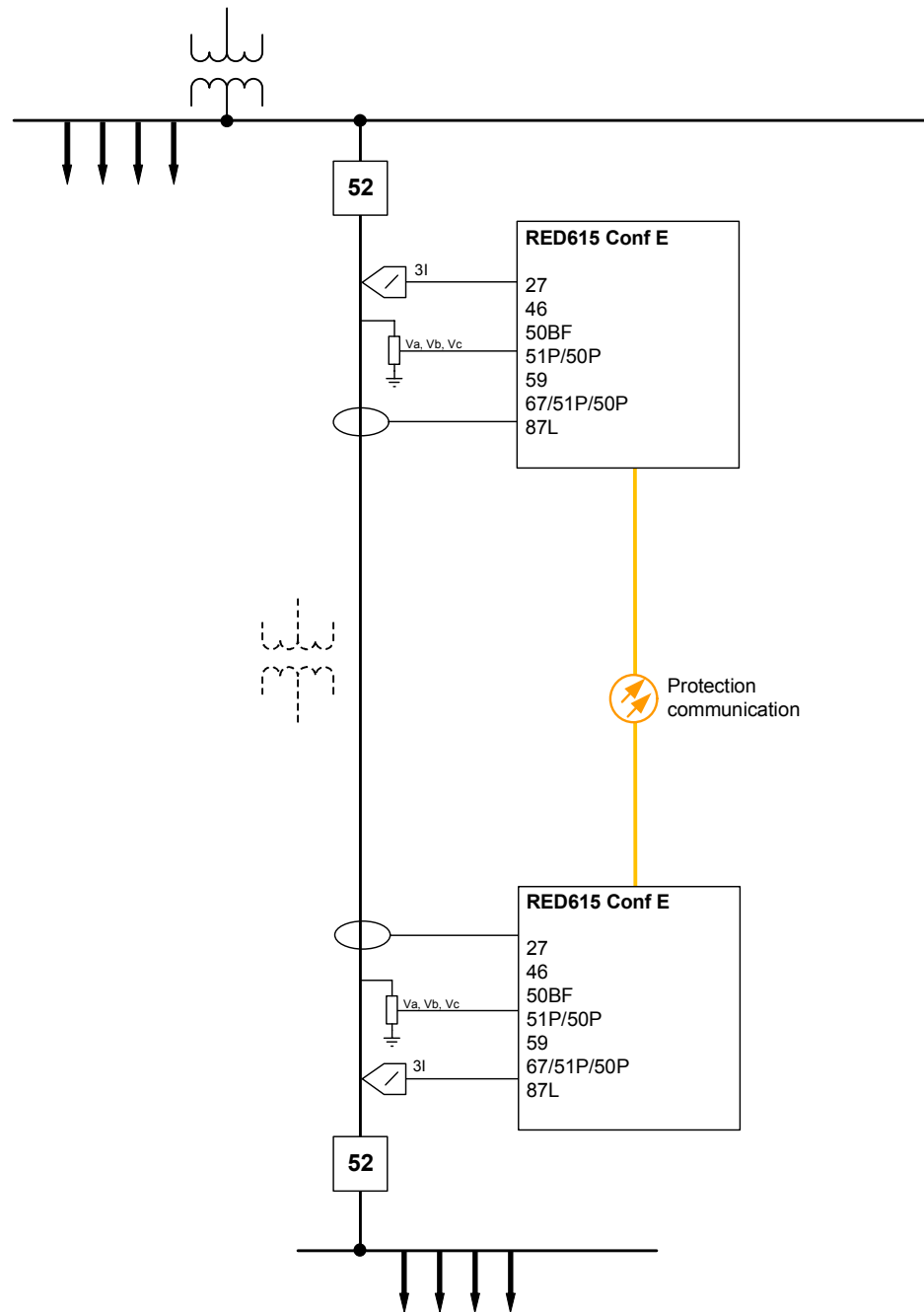

Figure 4 illustrates line differential protection of a feeder using the standard configuration E, in which current sensors (Rogowski coil) and voltage sensors (voltage divider) are used for the measurements. Additionally, protection is offered for an in-zone power transformer, when available and located in the protection zone.

The standard configuration E has been preconfigured especially for ABB switchgears, for example, SafeGear Digital. However, the use of this configuration is not restricted for this purpose only. Standard configurations D and E are not designed for using all the available functionality content in one relay at the same time. Frequency protection functions and third instances of voltage protection functions must be added with the Application Configuration tool. To ensure the performance of the relay, the user-specific configuration load is verified with the Application Configuration tool in PCM600.

5. Supported ABB solutions

The 615 series protection relays together with the Substation Management Unit COM600F constitute a genuine IEC 61850 solution for reliable power distribution in utility and industrial power systems. To facilitate the system engineering, ABB's relays are supplied with connectivity packages. The connectivity packages include a compilation of software and relay-specific information, including single-line diagram templates and a full relay data model. The data model includes event and parameter lists. With the connectivity packages, the relays can be readily configured using PCM600 and integrated with COM600F or the network control and management system MicroSCADA Pro.

The 615 series relays offer native support for IEC 61850 Edition 2 also including binary and analog horizontal GOOSE messaging. In addition, process bus with the sending of sampled values of analog currents and voltages and the receiving of sampled values of voltages is supported. Compared to traditional hard-wired, inter-device signaling, peer-to-peer communication over a switched Ethernet LAN offers an advanced and versatile platform for power system protection. Among the distinctive features of the protection system approach, enabled by the full implementation of the IEC 61850 substation automation standard, are fast communication capability, continuous supervision of the protection and communication system's integrity, and an inherent flexibility regarding reconfiguration and upgrades. This protection relay series is able to optimally utilize interoperability provided by the IEC 61850 Edition 2 features.

At substation level, COM600F uses the data content of the bay level devices to enhance substation level functionality.

COM600F features a Web browser-based HMI, which provides a customizable graphical display for visualizing single-line mimic diagrams for switchgear bay solutions. The Web HMI of COM600F also provides an overview of the whole substation, including relay-specific single-line diagrams, which makes information easily accessible. Substation devices and processes can also be remotely accessed through the Web HMI, which improves personnel safety.

In addition, COM600F can be used as a local data warehouse for the substation's technical documentation and for the network data collected by the devices. The collected network data facilitates extensive reporting and analyzing of network fault situations by using the data historian and event handling features of COM600F. The historical data can be used for accurate monitoring of process and equipment performance, using calculations based on both real-time and historical values. A better understanding of the process dynamics is achieved by combining time-based process measurements with production and maintenance events.

COM600F can also function as a gateway and provide seamless connectivity between the substation devices and network-level control and management systems, such as MicroSCADA Pro and System 800xA.

GOOSE Analyzer interface in COM600F enables the following and analyzing the horizontal IEC 61850 application during commissioning and operation at station level. It logs all GOOSE events during substation operation to enable improved system supervision.

Table 3. Supported ABB solutions

Title	Version
Substation Management Unit COM600F	5.0 or later (Edition 2)
MicroSCADA Pro SYS 600	9.4 or later (Edition 2)
System 800xA	5.1 or later

Figure 5. ABB power system example using Relion relays, COM600F and MicroSCADA Pro/ System 800xA

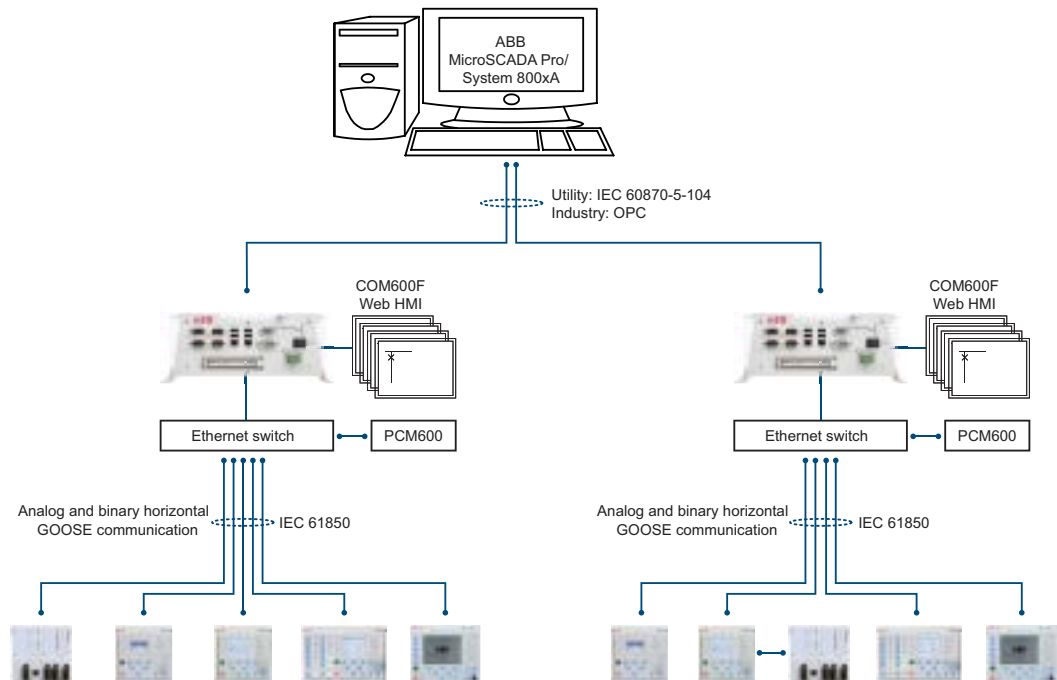

6. Control

RED615 integrates functionality for the control of a circuit breaker via the front panel HMI or by means of remote controls. In addition to the circuit-breaker control the relay features two control blocks which are intended for motor-operated control of disconnectors or circuit breaker truck and for their position indications. Further, the relay offers one control block which is intended for motor-operated control of one grounding switch control and its position indication.

Two physical binary inputs and two physical binary outputs are needed in the relay for each controllable primary device taken into use. The number of unused binary inputs and binary outputs varies depending on the chosen standard configuration. Further, some standard configurations also offer optional hardware modules that increase the number of available binary inputs and outputs.

If the amount of available binary inputs or outputs of the chosen standard configuration is not sufficient, the standard configuration can be modified to release some binary inputs or outputs

which have originally been configured for other purposes, when applicable, or an external input or output module such as RIO600 can be integrated to the relay. The binary inputs and outputs of the external I/O module can be used for the less time critical binary signals of the application. The integration enables the releasing of some initially reserved binary inputs and outputs of the relay in the standard configuration.

The suitability of the relay's binary outputs which have been selected for controlling of primary devices should be carefully verified, for example, the make and carry as well as the breaking capacity should be considered. In case the requirements for the control-circuit of the primary device are not met, the use of external auxiliary relays should be considered.

The large graphical LCD of the relay's HMI includes a single-line diagram (SLD) with position indication for the relevant primary devices. Interlocking schemes required by the application are configured using the signal matrix or the application configuration functionality of PCM600.

7. Measurements

The relay continuously measures the phase currents, the symmetrical components of the currents and the residual current. If the relay includes voltage measurements, it also measures the residual voltage. The relay also calculates the demand value of the current over a user-selectable, pre-set time frame, the thermal overload of the protected object, and the phase unbalance based on the ratio between the negative-sequence and positive-sequence current. Furthermore, the relay monitors the phase differential, bias and remote-end phase currents. The measured values can be accessed via the local HMI or remotely via the communication interface of the relay. The values can also be accessed locally or remotely using the Web HMI.

The relay is provided with a load profile recorder. The load profile feature stores the historical load data captured at a periodical time interval (demand interval). The records are in COMTRADE format.

8. Power quality

In the EN standards, power quality is defined through the characteristics of the supply voltage. Transients, short-duration and long-duration voltage variations and unbalance and waveform distortions are the key characteristics describing power quality. The distortion monitoring functions are used for monitoring the current total demand distortion and the voltage total harmonic distortion.

Power quality monitoring is an essential service that utilities can provide for their industrial and key customers. A monitoring system can provide information about system disturbances and their possible causes. It can also detect problem conditions throughout the system before they cause customer complaints, equipment malfunctions and even equipment damage or failure. Power quality problems are not limited to the utility side of the system. In fact, the majority of power quality problems are localized within customer facilities. Thus, power quality monitoring is not only an effective customer service strategy but also a way to protect a utility's reputation for quality power and service.

The protection relay has the following power quality monitoring functions.

- Voltage variation
- Voltage unbalance
- Current harmonics
- Voltage harmonics

The voltage unbalance and voltage variation functions are used for measuring short-duration voltage variations and monitoring voltage unbalance conditions in power transmission and distribution networks.

The voltage and current harmonics functions provide a method for monitoring the power quality by means of the current waveform distortion and voltage waveform distortion. The functions provides a short-term three-second average and a long-term demand for total demand distortion TDD and total harmonic distortion THD.

9. Fault location

RED615 features an optional impedance-measuring fault location function suitable for locating short-circuits in radial distribution systems. Ground faults can be located in effectively and low-resistance grounded networks. Under circumstances where the fault current magnitude is at least of the same order of magnitude or higher than the load current, ground faults can also be located in isolated neutral distribution networks. The fault location function identifies the type of the fault and then calculates the distance to the fault point. An estimate of the fault resistance value is also calculated. The estimate provides information about the possible fault cause and the accuracy of the estimated distance to the fault point.

10. Disturbance recorder

The relay is provided with a disturbance recorder featuring up to 12 analog and 64 binary signal channels. The analog channels can be set to record either the waveform or the trend of the currents and voltages measured.

The analog channels can be set to trigger the recording function when the measured value falls below or exceeds the set values. The binary signal channels can be set to start a recording either on the rising or the falling edge of the binary signal or on both.

By default, the binary channels are set to record external or internal relay signals, for example, the start or trip signals of the relay stages, or external blocking or control signals. Binary relay signals, such as protection start and trip signals, or an external relay control signal via a binary input, can be set to trigger the recording. Recorded information is stored in a non-volatile memory and can be uploaded for subsequent fault analysis.

11. Event log

To collect sequence-of-events information, the relay has a nonvolatile memory capable of storing 1024 events with the associated time stamps. The non-volatile memory retains its data even if the relay temporarily loses its auxiliary supply. The event log facilitates detailed pre- and post-fault analyses of feeder faults and disturbances. The considerable capacity to process and store data

and events in the relay facilitates meeting the growing information demand of future network configurations.

The sequence-of-events information can be accessed either via local HMI or remotely via the communication interface of the relay. The information can also be accessed locally or remotely using the Web HMI.

Figure 6. Recording and event capabilities overview

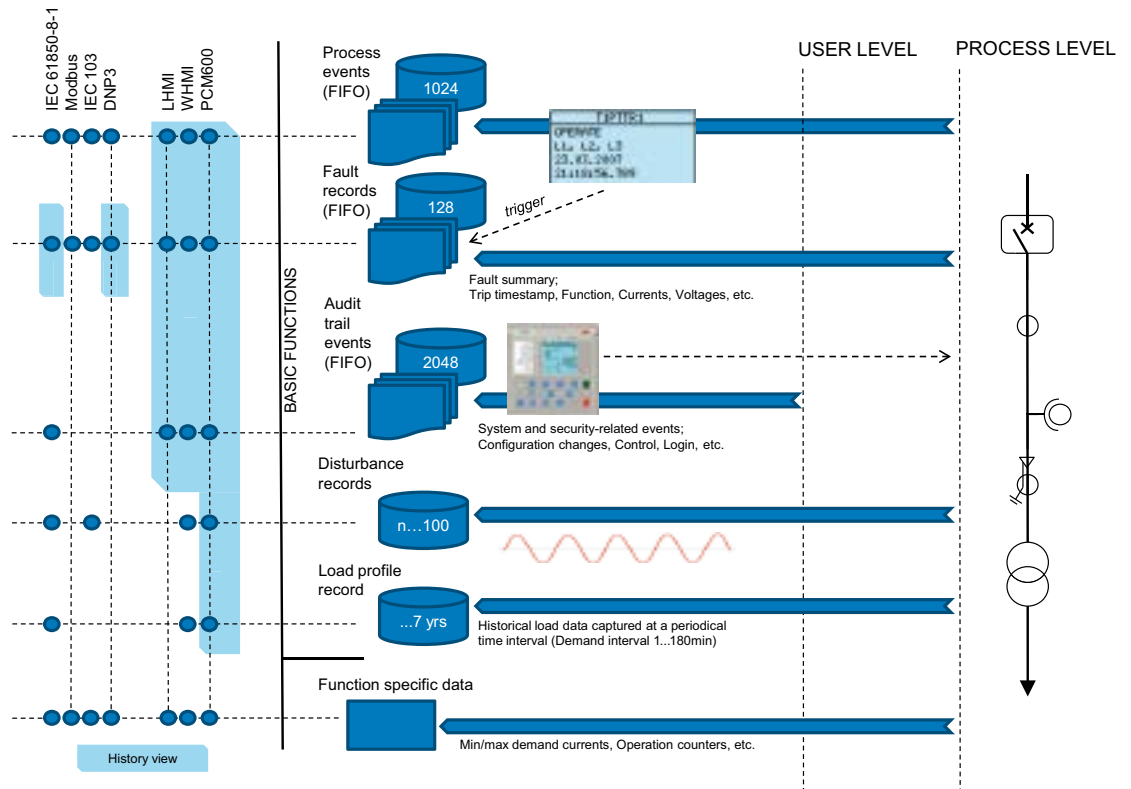

12. Recorded data

The relay has the capacity to store the records of the 128 latest fault events. The records can be used to analyze the power system events. Each record includes, for example, phase, differential and bias current values and a time stamp. The fault recording can be triggered by the start or the trip signal of a protection block, or by both. The available measurement modes include DFT, RMS and peak-to-peak. Fault records store relay measurement values at the moment when any protection function starts. In addition, the maximum demand current with time stamp is separately recorded. The records are stored in the non-volatile memory.

13. Condition monitoring

The condition monitoring functions of the relay constantly monitor the performance and the condition of the circuit breaker. The monitoring comprises the spring charging time, SF6 gas pressure, the travel time and the inactivity time of the circuit breaker.

The monitoring functions provide operational circuit breaker history data, which can be used for scheduling preventive circuit breaker maintenance.

In addition, the relay includes a runtime counter for monitoring of how many hours a protected device has been in operation thus enabling scheduling of time-based preventive maintenance of the device.

14. Trip-circuit supervision

The trip-circuit supervision continuously monitors the availability and operability of the trip circuit. It provides open circuit monitoring both when the circuit breaker is in its closed and in its open position. It also detects loss of circuit-breaker control voltage.

15. Self-supervision

The relay's built-in self-supervision system continuously monitors the state of the relay hardware and the operation of the relay software. Any fault or malfunction detected is used for alerting the operator. A permanent relay fault blocks the protection functions to prevent incorrect operation.

16. Current circuit supervision

The relay includes current circuit supervision. Current circuit supervision is used for detecting faults in the current transformer secondary circuits. On detecting of a fault the current circuit supervision function activates an alarm LED and blocks the line differential protection and negative-sequence overcurrent protection functions to avoid unintended operation. The current circuit supervision function calculates the sum of the phase currents from the protection cores and compares the sum with the measured single reference current from a core balance current transformer or from separate cores in the phase current transformers.

17. Protection communication and supervision

The communication between the relays is enabled by means of a dedicated fiber optic communication channel. 1310 nm multimode or single-mode fibers with LC connectors are used for line differential communication. The channel is used for transferring the phase segregated current value data between the relays. The current phasors from the two relays, geographically located apart from each other, must be time coordinated so that the current differential algorithm can be executed correctly. The so called echo method is used for time synchronization. No external devices such as GPS clocks are thereby needed for the line differential protection communication.

As an option to the fiber optic communication link a galvanic connection over a pilot wire link composed of a twisted pair cable and RPW600 link-end communication modems can be established. The optional pilot wire communication link is also an ideal and cost efficient retrofit solution for electromechanical line differential protection installations. Compared to conventional combined

sequence line differential protection solutions with analog pilot wire communication, RED615 relays in combination with RPW600 communication modems offer a modern phase-segregated line differential protection solution over existing pilot wire cables.

The pilot wire link supports the same protection and communication functionality as the fiber optic link. The quality of service (QoS) is indicated by the modems and the communication link is continuously supervised by the relay. The RPW600 modem offers a 5 kV (RMS) level of isolation between the pilot wire terminals and ground. The RPW600 modems (master and follower) are galvanically connected to either end of the pilot wire and optically connected to the relays using short optical single-mode cables. Using 0.8 mm² twisted pair cables pilot wire link distances up to 8 km are typically supported. However, twisted pair pilot wire cables in good conditions may support even longer distances to be covered. The length of the supported pilot wire link also depends on the noise environment in the installation. Should the need arise to replace the pilot wire cables with fiber optic cables, the single mode fiber optic LC connectors of the relays can be utilized for direct connection of the fiber optic communication link.

Apart from the continued protection communication, the communication channel can also be used for binary signal transfer (BST) that is, transferring of user configurable binary information between the relays. There are a total of eight BST signals available for user definable purposes. The BST signals can originate from the relay's binary inputs or internal logics, and be assigned to the remote relay's binary outputs or internal logics.

The protection communication supervision continuously monitors the protection communication link. The relay immediately blocks the line differential protection function in case that severe interference in the communication link, risking the correct operation of the function, is detected. An alarm signal will eventually be issued if the interference, indicating permanent failure in the protection communication, persists. The two high-set stages of the overcurrent protection are further by default released.

Figure 7. Fiber optic protection communication link

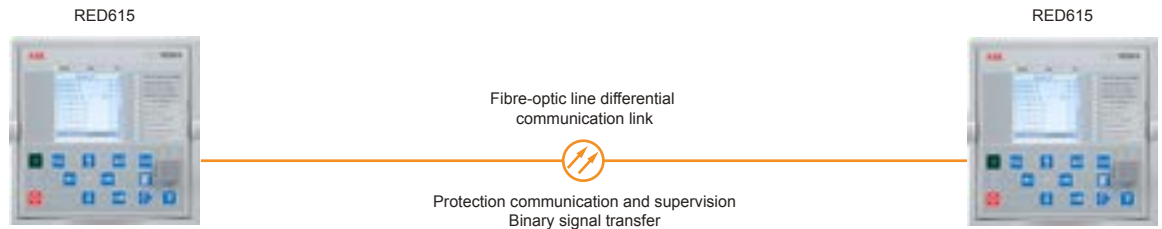
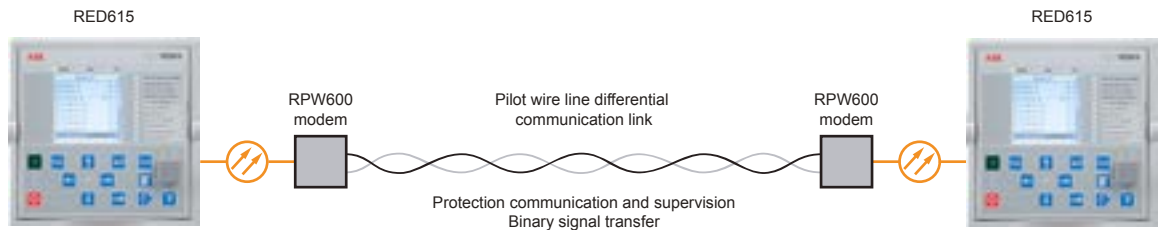

Figure 8. Pilot wire protection communication link



18. Access control

To protect the relay from unauthorized access and to maintain information integrity, the relay is provided with a four-level, role based authentication system with administrator-programmable individual passwords for the viewer, operator, engineer and administrator levels. The access control applies to the local HMI, the Web HMI and PCM600.

19. Inputs and outputs

Depending on the standard configuration selected, the relay is equipped with three phase-current inputs and one residual current input for non-directional ground-fault protection and current circuit supervision, or three phase-current inputs, one residual-current input and one residual voltage input for directional ground-fault protection and current circuit supervision.

The standard configuration E includes one conventional residual current (Io 0.2/1 A) input and three sensor inputs for the direct connection of three combi-sensors with RJ-45 connectors. As an alternative to combi-sensors, separate current and voltage sensors can be utilized using adapters.

Furthermore, the adapters also enable the use of sensors with Twin-BNC connectors. The phase-current inputs are rated 1/5 A. Two optional residual-current inputs are available, that is, 1/5 A or 0.2/1 A. The 0.2/1 A input is normally used in applications requiring sensitive ground-fault protection and featuring core-balance current transformers. The residual-voltage input covers the rated voltages 60...210 V.

The phase-current input 1 A or 5 A, the residual-current input 1 A or 5 A, alternatively 0.2 A or 1 A, and the rated voltage of the residual voltage input are selected in the relay software. In addition, the binary input thresholds 16...176 V DC are selected by adjusting the relay's parameter settings. All binary inputs and outputs contacts are freely configurable with the signal matrix or application configuration functionality of PCM600.

See the Input/output overview table and the terminal diagrams for more information about the inputs and outputs.

Table 4. Input/output overview

Std. conf.	Order code digit		Analog channels			Binary channels			
	5-6	7-8	CT	VT	Combi-sensor	BI	BO	RTD	mA
D	AE/AF	AG	4	5		16	4 PO + 6 SO	-	-
	FE/FF	AD	4	5		12	4 PO + 6 SO	2	1
E	DA	AH	1	-	3	8	4 PO + 6 SO	-	-

20. Station communication

The relay supports a range of communication protocols including IEC 61850 Edition 2, IEC 61850-9-2 LE, Modbus® and DNP3. Operational information and controls are available through these protocols. However, some communication functionality, for example, horizontal communication between the relays, is only enabled by the IEC 61850 communication protocol.

The IEC 61850 protocol is a core part of the relay as the protection and control application is fully based on standard modelling. The relay supports Edition 2 and Edition 1 versions of the standard. With Edition 2 support, the relay has the latest functionality modelling for substation applications and the best interoperability for modern substations. It incorporates also the full support of standard device mode functionality supporting different test applications. Control applications can utilize the new safe and advanced station control authority feature.

The IEC 61850 communication implementation supports monitoring and control functions. Additionally, parameter settings, disturbance recordings and fault records can be accessed using the IEC 61850 protocol. Disturbance recordings are available to any Ethernet-based application in the standard COMTRADE file format. The relay supports simultaneous event reporting to five different clients on the station bus. The relay can exchange data with other devices using the IEC 61850 protocol.

The relay can send binary and analog signals to other devices using the IEC 61850-8-1 GOOSE (Generic Object Oriented Substation Event) profile. Binary GOOSE messaging can, for example, be employed for protection and interlocking-based protection schemes. The relay meets the GOOSE performance requirements for tripping

applications in distribution substations, as defined by the IEC 61850 standard (<10 ms data exchange between the devices). The relay also supports the sending and receiving of analog values using GOOSE messaging. Analog GOOSE messaging enables easy transfer of analog measurement values over the station bus, thus facilitating for example the sending of measurement values between the relays when controlling parallel running transformers.

The relay also supports IEC 61850 process bus by sending sampled values of analog currents and voltages and by receiving sampled values of voltages. With this functionality the galvanic interpanel wiring can be replaced with Ethernet communication. The measured values are transferred as sampled values using IEC 61850-9-2 LE protocol. The intended application for sampled values shares the voltages to other 615 series relays, having voltage based functions and 9-2 support. 615 relays with process bus based applications use IEEE 1588 for high accuracy time synchronization.

For redundant Ethernet communication, the relay offers two optical Ethernet network interfaces. Ethernet network redundancy can be achieved using the high-availability seamless redundancy (HSR) protocol or the parallel redundancy protocol (PRP) or a with self-healing ring using RSTP in managed switches. Ethernet redundancy can be applied to Ethernet-based IEC 61850, Modbus and DNP3 protocols.

All communication card variants support self-healing ring based Ethernet redundancy. Communication card variants with two optical interfaces for station bus communication have support for HSR and PRP redundancy protocols. These variants include also support for IEEE 1588 based time synchronization.

The IEC 61850 standard specifies network redundancy which improves the system availability for the substation communication. The network redundancy is based on two complementary protocols defined in the IEC 62439-3 standard: PRP and HSR protocols. Both the protocols are able to overcome a failure of a link or switch with a zero switch-over time. In both the protocols, each network node has two identical Ethernet ports dedicated for one network connection. The protocols rely on the duplication of all transmitted information and provide a zero switch-over time if

the links or switches fail, thus fulfilling all the stringent real-time requirements of substation automation.

In PRP, each network node is attached to two independent networks operated in parallel. The networks are completely separated to ensure failure independence and can have different topologies. The networks operate in parallel, thus providing zero-time recovery and continuous checking of redundancy to avoid failures.

Figure 9. Parallel redundancy protocol (PRP) solution

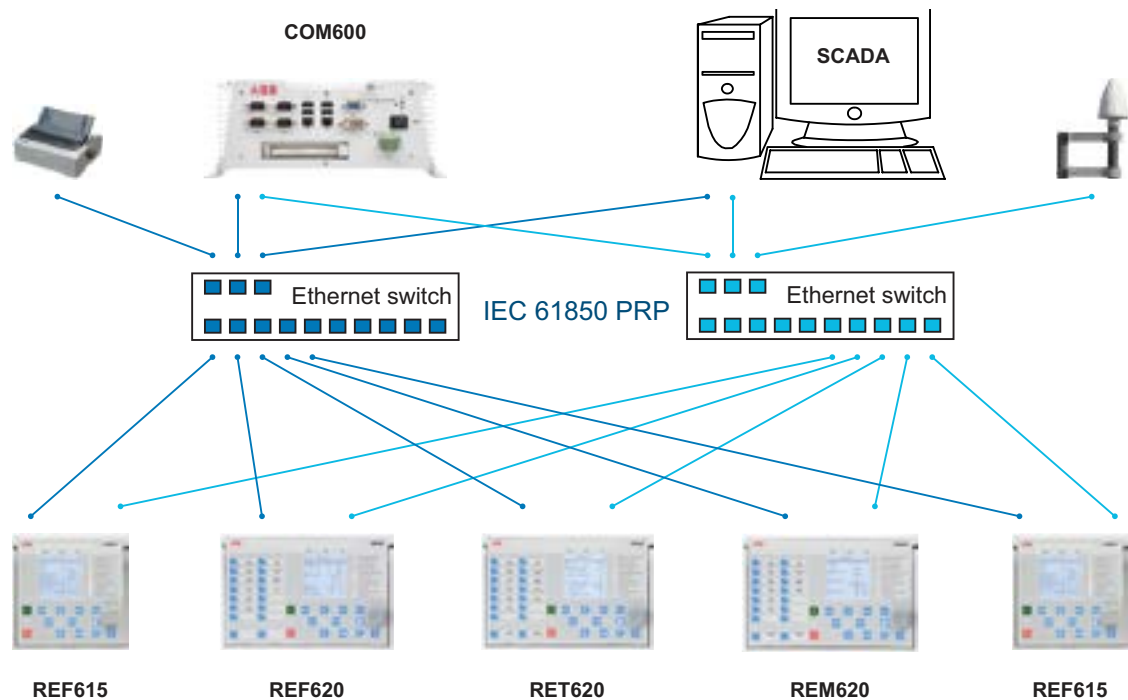

HSR applies the PRP principle of parallel operation to a single ring. For each message sent, the node sends two frames, one through each port. Both the frames circulate in opposite directions over the ring. Every node forwards the frames it receives from one port to another to reach the next node. When the originating sender node receives the

frame it sent, the sender node discards the frame to avoid loops. The HSR ring with 615 series relays supports the connection of up to 30 relays. If more than 30 relays are to be connected, it is recommended to split the network into several rings to guarantee the performance for real-time applications.

Figure 10. High availability seamless redundancy (HSR) solution

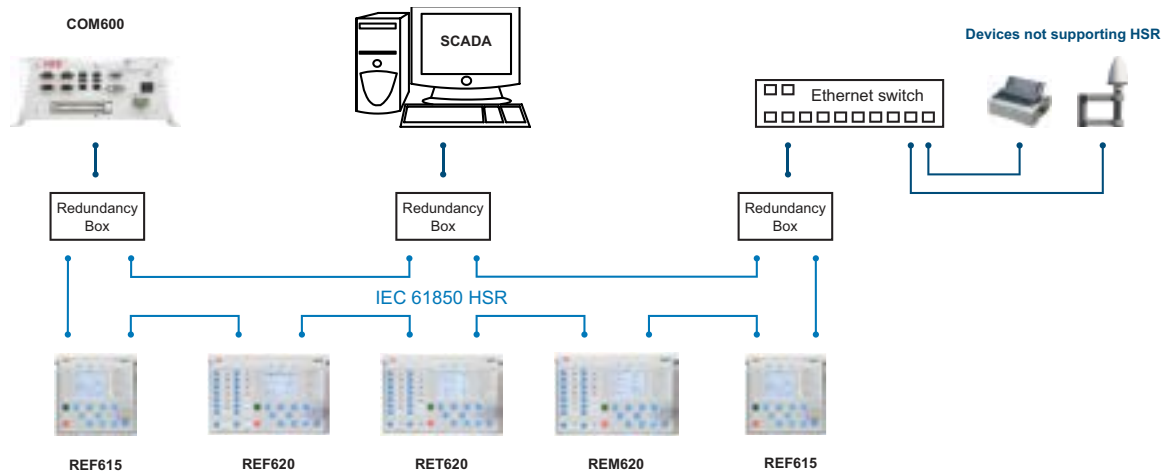

The choice between the HSR and PRP redundancy protocols depends on the required functionality, cost and complexity.

The self-healing Ethernet ring solution enables a cost-efficient communication ring controlled by a managed switch with standard Rapid Spanning Tree Protocol (RSTP) support. The managed switch controls the consistency of the loop, routes the data and corrects the data flow in case of a communication switch-over. The relays in the ring topology act as unmanaged switches forwarding unrelated data traffic. The Ethernet ring solution

supports the connection of up to 30 615 series relays. If more than 30 relays are to be connected, it is recommended to split the network into several rings. The self-healing Ethernet ring solution avoids single point of failure concerns and improves the reliability of the communication.

The self-healing Ethernet ring solution avoids single point of failure concerns and improves the reliability of the communication. The solution can be applied for the Ethernet based IEC 61850, Modbus and DNP3 protocols.

Figure 11. Self-healing Ethernet ring solution

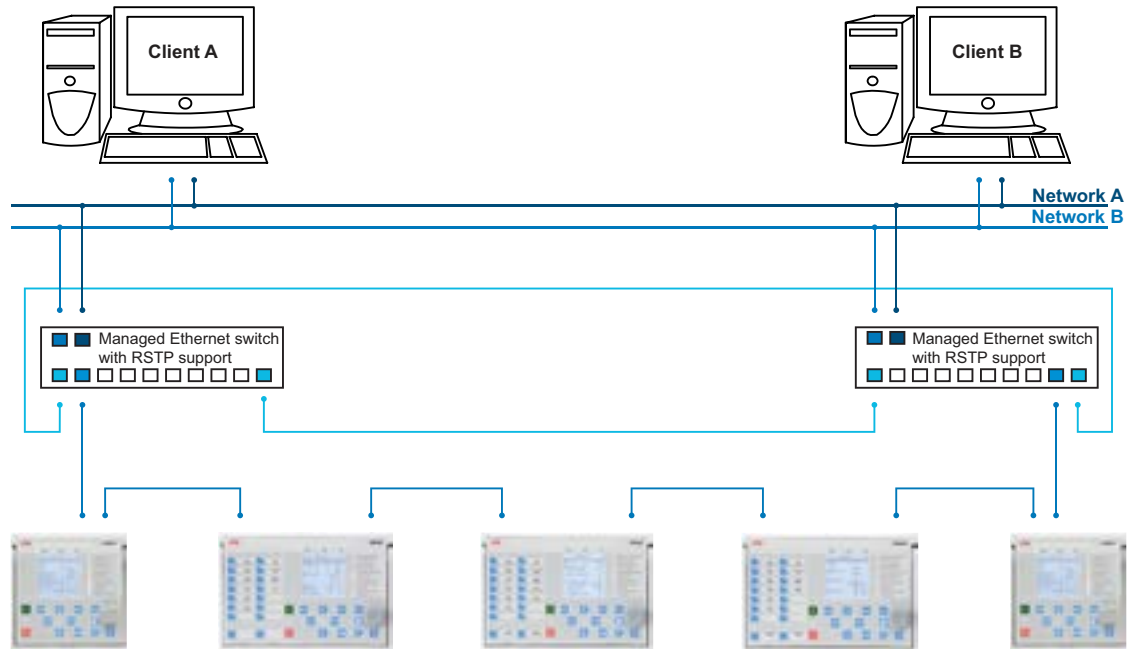

All communication connectors, except for the front port connector, are placed on integrated optional communication modules. The relay can be connected to Ethernet-based communication systems via the RJ-45 connector (100Base-TX) or the fiber optic LC connector (100Base-FX).

Modbus implementation supports RTU, ASCII and TCP modes. Besides standard Modbus functionality, the relay supports retrieval of time-stamped events, changing the active setting group and uploading of the latest fault records. If a Modbus TCP connection is used, five clients can be connected to the relay simultaneously. Further, Modbus serial and Modbus TCP can be used in parallel, and if required both IEC 61850 and Modbus protocols can be run simultaneously.

DNP3 supports both serial and TCP modes for connection up to five masters. Changing of the active setting and reading fault records are supported. DNP serial and DNP TCP can be used in parallel. If required, both IEC 61850 and DNP protocols can be run simultaneously.

When the relay uses the RS-485 bus for the serial communication, both two- and four-wire connections are supported. Termination and pull-up/down resistors can be configured with jumpers on the communication card so external resistors are not needed.

The relay supports the following time synchronization methods with a time-stamping resolution of 1 ms.

Ethernet-based

- SNTP (Simple Network Time Protocol)

With special time synchronization wiring

- IRIG-B (Inter-Range Instrumentation Group - Time Code Format B)

Remote-end station time reference

- Line differential

The relay supports the following high accuracy time synchronization method with a time-stamping resolution of 4 μ s required especially in process bus applications.

- PTP (IEEE 1588) v2 with Power Profile

The IEEE 1588 support is included in all variants having a redundant Ethernet communication module.

IEEE 1588 v2 features

- Ordinary Clock with Best Master Clock algorithm
- One-step Transparent Clock for Ethernet ring topology
- 1588 v2 Power Profile
- Receive (slave): 1-step/2-step
- Transmit (master): 1-step

- Layer 2 mapping
- Peer to peer delay calculation
- Multicast operation

Required accuracy of grandmaster clock is +/-1 μ s. The relay can work as a master clock per BMC algorithm if the external grandmaster clock is not available for short term.

The IEEE 1588 support is included in all variants having a redundant Ethernet communication module.

In addition, the relay supports time synchronization via Modbus, and DNP3 serial communication protocols.

Table 5. Supported station communication interfaces and protocols

Interfaces/Protocols	Ethernet		Serial	
	100BASE-TX RJ-45	100BASE-FX LC	RS-232/RS-485	Fiber optic ST
IEC 61850-8-1	•	•	-	-
IEC 61850-9-2 LE	•	•	-	-
MODBUS RTU/ASCII	-	-	•	•
MODBUS TCP/IP	•	•	-	-
DNP3 (serial)	-	-	•	•
DNP3 TCP/IP	•	•	-	-

• = Supported

21. Technical data

—
Table 6. Dimensions

Description	Value	
Width	Frame	177 mm
	Case	164 mm
Height	Frame	177 mm (4U)
	Case	160 mm
Depth	201 mm (153 + 48 mm)	
Weight	Complete protection relay	4.1 kg
	Plug-in unit only	2.1 kg

—
Table 7. Power supply

Description	Type 1	Type 2
Nominal auxiliary voltage U_n	100, 110, 120, 220, 240 V AC, 50 and 60 Hz	24, 30, 48, 60 V DC
	48, 60, 110, 125, 220, 250 V DC	
Maximum interruption time in the auxiliary DC voltage without resetting the relay	50 ms at U_n	
Auxiliary voltage variation	38...110% of U_n (38...264 V AC)	50...120% of U_n (12...72 V DC)
	80...120% of U_n (38.4...300 V DC)	
Start-up threshold		19.2 V DC (24 V DC × 80%)
Burden of auxiliary voltage supply under quiescent (P_q)/operating condition	DC <13.0 W (nominal)/<18.0 W (max.)	DC <13.0 W (nominal)/<18.0 W (max.)
	AC <16.0 W (nominal)/<21.0 W (max.)	
Ripple in the DC auxiliary voltage	Max 15% of the DC value (at frequency of 100 Hz)	
Fuse type	T4A/250 V	

—
Table 8. Energizing inputs

Description	Value	
Rated frequency	50/60 Hz	
Current inputs	Rated current, I_n	0.2/1 A
	Thermal withstand capability:	1/5 A ¹⁾
		• Continuously
	• For 1 s	100 A
	Dynamic current withstand:	20 A
• Half-wave value		250 A
Input impedance	<100 mΩ	1250 A
Voltage inputs	Rated voltage	<20 mΩ
	Voltage withstand:	60...210 V AC
		• Continuous
	• For 10 s	360 V AC
Burden at rated voltage	<0.05 VA	

1) Ordering option for residual current input

Table 9. Energizing inputs (sensors)

Description	Value	
Current sensor inputs	Rated current voltage (in secondary side) Rated current	75 mV...9000 mV ¹⁾
	Continuous voltage withstand	125 V
	Input impedance at 50/60 Hz	2...3 M Ω ²⁾
Voltage sensor inputs	Rated voltage	6 kV...30 kV ³⁾
	Continuous voltage withstand	50 V
	Input impedance at 50/60 Hz	3 M Ω ²⁾

1) Equals the current range of 40...4000 A with a 80 A, 3 mV/Hz Rogowski

2) Depending on the used nominal current (hardware gain)

3) This range is covered (up to 2*rated) with sensor division ratio of 10 000:1

Table 10. Binary inputs

Description	Value
Operating range	$\pm 20\%$ of the rated voltage
Rated voltage	24...250 V DC
Current drain	1.6...1.9 mA
Power consumption	31.0...570.0 mW
Threshold voltage	16...176 V DC
Reaction time	<3 ms

Table 11. RTD/mA measurement (XRGGIO130)

Description	Value		
RTD inputs	Supported RTD sensors	100 Ω platinum TCR 0.00385 (DIN 43760) 250 Ω platinum TCR 0.00385 100 Ω nickel TCR 0.00618 (DIN 43760) 120 Ω nickel TCR 0.00618 250 Ω nickel TCR 0.00618 10 Ω copper TCR 0.00427	
	Supported resistance range	0...2 k Ω	
	Maximum lead resistance (three-wire measurement)	25 Ω per lead	
	Isolation	2 kV (inputs to protective ground)	
	Response time	<4 s	
	RTD/resistance sensing current	Maximum 0.33 mA rms	
	Operation accuracy	Resistance	$\pm 2.0\%$ or $\pm 1 \Omega$
		Temperature	$\pm 1^\circ\text{C}$ 10 Ω copper: $\pm 2^\circ\text{C}$
	mA inputs	Supported current range	0...20 mA
		Current input impedance	44 $\Omega \pm 0.1\%$
Operation accuracy		$\pm 0.5\%$ or $\pm 0.01 \text{ mA}$	

—
Table 12. Signal output X100: SO1

Description	Value
Rated voltage	250 V AC/DC
Continuous contact carry	5 A
Make and carry for 3.0 s	15 A
Make and carry for 0.5 s	30 A
Breaking capacity when the control-circuit time constant L/R<40 ms	1 A/0.25 A/0.15 A
Minimum contact load	100 mA at 24 V AC/DC

—
Table 13. Signal outputs and IRF output

Description	Value
Rated voltage	250 V AC/DC
Continuous contact carry	5 A
Make and carry for 3.0 s	10 A
Make and carry 0.5 s	15 A
Breaking capacity when the control-circuit time constant L/R<40 ms, at 48/110/220 V DC	1 A/0.25 A/0.15 A
Minimum contact load	10 mA at 5 V AC/DC

—
Table 14. Double-pole power output relays with TCS function

Description	Value
Rated voltage	250 V AC/DC
Continuous contact carry	8 A
Make and carry for 3.0 s	15 A
Make and carry for 0.5 s	30 A
Breaking capacity when the control-circuit time constant L/R<40 ms, at 48/110/220 V DC (two contacts connected in series)	5 A/3 A/1 A
Minimum contact load	100 mA at 24 V AC/DC
Trip-circuit supervision (TCS):	
1) Control voltage range	20...250 V AC/DC
2) Current drain through the supervision circuit	~1.5 mA
3) Minimum voltage over the TCS contact	20 V AC/DC (15...20 V)

—
Table 15. Single-pole power output relays

Description	Value
Rated voltage	250 V AC/DC
Continuous contact carry	8 A
Make and carry for 3.0 s	15 A
Make and carry for 0.5 s	30 A
Breaking capacity when the control-circuit time constant L/R<40 ms, at 48/110/220 V DC	5 A/3 A/1 A
Minimum contact load	100 mA at 24 V AC/DC

—
Table 16. High-speed output HSO with BIO0007

Description	Value
Rated voltage	250 V AC/DC
Continuous contact carry	6 A
Make and carry for 3.0 s	15 A
Make and carry for 0.5 s	30 A
Breaking capacity when the control-circuit time constant $L/R < 40$ ms, at 48/110/220 V DC (two contacts connected in series)	5 A/3 A/1 A
Operate time	<1 ms
Reset	<20 ms, resistive load

—
Table 17. Front port Ethernet interfaces

Ethernet interface	Protocol	Cable	Data transfer rate ^W
Front	TCP/IP protocol	Standard Ethernet CAT 5 cable with RJ-45 connector	10 Mbits/s

—
Table 18. Protection communication link

Connector	Fibre type	Wave length	Typical max. length ¹⁾	Permitted path attenuation ²⁾
LC	MM 62.5/125 or 50/125 μm	1300 nm	2 km	<8 dB
LC	SM 9/125 μm ³⁾	1300 nm	20 km	<8 dB

1) Maximum length depends on the cable attenuation and quality, the amount of splices and connectors in the path

2) Maximum allowed attenuation caused by connectors and cable altogether

3) Use single-mode fiber with recommended minimum length of 3 m to connect RED615 to the pilot wire modem RPW600

—
Table 19. IRIG-B

Description	Value
IRIG time code format	B004, B005 ¹⁾
Isolation	500V 1 min
Modulation	Unmodulated
Logic level	5 V TTL
Current consumption	<4 mA
Power consumption	<20 mW

1) According to the 200-04 IRIG standard

—
Table 20. Degree of protection of flush-mounted protection relay

Description	Value
Front side	IP54
Rear side, connection terminals	IP 10
Left and right side	IP 20
Top and bottom	IP 20

Table 21. Environmental conditions

Description	Value
Operating temperature range	-25...+55°C (continuous)
Short-time service temperature range	-40...+70°C (<16h) ¹⁾²⁾
Relative humidity	<93%, non-condensing
Atmospheric pressure	86...106 kPa
Altitude	Up to 2000 m
Transport and storage temperature range	-40...+85°C

1) Degradation in MTBF and HMI performance outside the temperature range of -25...+55 °C

2) For relays with an LC communication interface the maximum operating temperature is +70 °C

Table 22. Electromagnetic compatibility tests

Description	Type test value	Reference
1 MHz/100 kHz burst disturbance test		IEC 61000-4-18 IEC 60255-26, class III IEEE C37.90.1-2002
• Common mode	2.5 kV	
• Differential mode	2.5 kV	
3 MHz, 10 MHz and 30 MHz burst disturbance test		IEC 61000-4-18 IEC 60255-26, class III
• Common mode	2.5 kV	
Electrostatic discharge test		IEC 61000-4-2 IEC 60255-26 IEEE C37.90.3-2001
• Contact discharge	8 kV	
• Air discharge	15 kV	
Radio frequency interference test		IEC 61000-4-6 IEC 60255-26, class III IEC 61000-4-3 IEC 60255-26, class III ENV 50204 IEC 60255-26, class III IEEE C37.90.2-2004
	10 V (rms) f = 150 kHz...80 MHz 10 V/m (rms) f = 80...2700 MHz 10 V/m f = 900 MHz 20 V/m (rms) f = 80...1000 MHz	
Fast transient disturbance test		IEC 61000-4-4 IEC 60255-26 IEEE C37.90.1-2002
• All ports	4 kV	
Surge immunity test		IEC 61000-4-5 IEC 60255-26
• Communication	1 kV, line-to-ground	
• Other ports	4 kV, line-to-ground 2 kV, line-to-line	
Power frequency (50 Hz) magnetic field immunity test		IEC 61000-4-8
• Continuous	300 A/m	
• 1...3 s	1000 A/m	
Pulse magnetic field immunity test	1000 A/m 6.4/16 µs	IEC 61000-4-9
Damped oscillatory magnetic field immunity test		IEC 61000-4-10
• 2 s	100 A/m	

—
Table 22. Electromagnetic compatibility tests (continued)

Description	Type test value	Reference
• 1 MHz	400 transients/s	
Voltage dips and short interruptions	30%/10 ms 60%/100 ms 60%/1000 ms >95%/5000 ms	IEC 61000-4-11
Power frequency immunity test	Binary inputs only	IEC 61000-4-16 IEC 60255-26, class A
• Common mode	300 V rms	
• Differential mode	150 V rms	
Conducted common mode disturbances	15 Hz...150 kHz Test level 3 (10/1/10 V rms)	IEC 61000-4-16
Emission tests		EN 55011, class A IEC 60255-26 CISPR 11 CISPR 12
• Conducted		
0.15...0.50 MHz	<79 dB (μV) quasi peak <66 dB (μV) average	
0.5...30 MHz	<73 dB (μV) quasi peak <60 dB (μV) average	
• Radiated		
30...230 MHz	<40 dB (μV/m) quasi peak, measured at 10 m distance	
230...1000 MHz	<47 dB (μV/m) quasi peak, measured at 10 m distance	
1...3 GHz	<76 dB (μV/m) peak <56 dB (μV/m) average, measured at 3 m distance	
3...6 GHz	<80 dB (μV/m) peak <60 dB (μV/m) average, measured at 3 m distance	

—
Table 23. Insulation tests

Description	Type test value	Reference
Dielectric tests	2 kV, 50 Hz, 1 min 500 V, 50 Hz, 1 min, communication	IEC 60255-27
Impulse voltage test	5 kV, 1.2/50 μs, 0.5 J 1 kV, 1.2/50 μs, 0.5 J, communication	IEC 60255-27
Insulation resistance measurements	>100 MΩ, 500 V DC	IEC 60255-27
Protective bonding resistance	<0.1 Ω, 4 A, 60 s	IEC 60255-27

—
Table 24. Mechanical tests

Description	Reference	Requirement
Vibration tests (sinusoidal)	IEC 60068-2-6 (test Fc) IEC 60255-21-1	Class 2
Shock and bump test	IEC 60068-2-27 (test Ea shock) IEC 60068-2-29 (test Eb bump) IEC 60255-21-2	Class 2
Seismic test	IEC 60255-21-3	Class 2

—
Table 25. Environmental tests

Description	Type test value	Reference
Dry heat test	• 96 h at +55°C • 16 h at -70°C ¹⁾	IEC 60068-2-2
Dry cold test	• 96 h at -25°C • 16 h at -40°C	IEC 60068-2-1
Damp heat test	• 6 cycles (12 h + 12 h) at +25°C...+55°C, humidity >93%	IEC 60068-2-30
Change of temperature test	• 5 cycles (3 h + 3 h) at -25°C...+55°C	IEC60068-2-14
Storage test	• 96 h at -40°C • 96 h at +85°C	IEC 60068-2-1 IEC 60068-2-2

1) For relays with an LC communication interface the maximum operating temperature is +70°C

—
Table 26. Product safety

Description	Reference
LV directive	2006/95/EC
Standard	EN 60255-27 (2013) EN 60255-1 (2009)

—
Table 27. EMC compliance Table 24. Product safety

Description	Reference
EMC directive	2004/108/EC
Standard	EN 60255-26 (2013)

—
Table 28. RoHS compliance

Description
Complies with RoHS directive 2002/95/EC

Protection functions

Table 29. Three-phase non-directional overcurrent protection (PHxPTOC)

Description	Type test value	Reference		
Operation accuracy	PHIPTOC	$\pm 1.5\%$ of set value or $\pm 0.002 \times I_n$ (at currents in the range of $0.1 \dots 10 \times I_n$) $\pm 5.0\%$ of the set value (at currents in the range of $10 \dots 40 \times I_n$)		
Start time ¹⁾²⁾		Minimum	Typical	Maximum
	PHIPTOC:			
	$I_{Fault} = 2 \times \text{set Start value}$	16 ms	19 ms	23 ms
	$I_{Fault} = 10 \times \text{set Start value}$	11 ms	12 ms	14 ms
Reset time		Typically 40 ms		
Reset ratio		Typically 0.96		
Retardation time		<30 ms		
Operate time accuracy in definite time mode		$\pm 1.0\%$ of the set value or ± 20 ms		
Operate time accuracy in inverse time mode		$\pm 5.0\%$ of the theoretical value or ± 20 ms ³⁾		
Suppression of harmonics		RMS: No suppression DFT: -50 dB at $f = n \times f_n$, where $n = 2, 3, 4, 5, \dots$ Peak-to-Peak: No suppression P-to-P+backup: No suppression		

1) Set Operate delay time = 0,02 s, Operate curve type = IEC definite time, Measurement mode = default (depends on stage), current before fault = $0.0 \times I_n$, $f_n = 50$ Hz, fault current in one phase with nominal frequency injected from random phase angle, results based on statistical distribution of 1000 measurements

2) Includes the delay of the signal output contact

3) Includes the delay of the heavy-duty output contact

Table 30. Three-phase non-directional overcurrent protection (PHxPTOC) main settings

Parameter	Function	Value (Range)	Step
Start value	PHIPTOC	$1.00 \dots 40.00 \times I_n$	0.01
Operate delay time	PHLPTOC and PHHPTOC	40...200000 ms	10
	PHIPTOC	20...200000 ms	10
Operating curve type ¹⁾	PHIPTOC	Definite time	

1) For further reference, see the Operation characteristics table

Table 31. Three-phase directional overcurrent protection (DPHxPDOC)

Characteristic	Value			
Operation accuracy	DPHLPDOC	Depending on the frequency of the current/voltage measured: $f_n \pm 2$ Hz Current: $\pm 1.5\%$ of the set value or $\pm 0.002 \times I_n$ Voltage: $\pm 1.5\%$ of the set value or $\pm 0.002 \times U_n$ Phase angle: $\pm 2^\circ$		
	DPHHPDOC	Current: $\pm 1.5\%$ of the set value or $\pm 0.002 \times I_n$ (at currents in the range of $0.1 \dots 10 \times I_n$) $\pm 5.0\%$ of the set value (at currents in the range of $10 \dots 40 \times I_n$) Voltage: $\pm 1.5\%$ of the set value or $\pm 0.002 \times U_n$ Phase angle: $\pm 2^\circ$		
Start time ¹⁾²⁾	$I_{Fault} = 2.0 \times \text{set Start value}$	Minimum	Typical	Maximum
		39 ms	43 ms	47 ms
Reset time	Typically 40 ms			
Reset ratio	Typically 0.96			
Retardation time	<35 ms			
Operate time accuracy in definite time mode	$\pm 1.0\%$ of the set value or ± 20 ms			
Operate time accuracy in inverse time mode	$\pm 5.0\%$ of the theoretical value or ± 20 ms ³⁾			
Suppression of harmonics	DFT: -50 dB at $f = n \times f_n$, where $n = 2, 3, 4, 5, \dots$			

1) Measurement mode and Pol quantity = default, current before fault = $0.0 \times I_n$, voltage before fault = $1.0 \times U_n$, $f_n = 50$ Hz, fault current in one phase with nominal frequency injected from random phase angle, results based on statistical distribution of 1000 measurements

2) Includes the delay of the signal output contact

3) Maximum Start value = $2.5 \times I_n$, Start value multiples in range of 1.5...20

Table 32. Three-phase directional overcurrent protection (DPHxPDOC) main settings

Parameter	Function	Value (Range)	Step
Start value	DPHLPDOC	$0.05 \dots 5.00 \times I_n$	0.01
	DPHHPDOC	$0.10 \dots 40.00 \times I_n$	0.01
Time multiplier	DPHxPDOC	$0.05 \dots 15.00$	0.01
Operate delay time	DPHxPDOC	$40 \dots 200000$ ms	10
Directional mode	DPHxPDOC	1 = Non-directional	
		2 = Forward	
		3 = Reverse	
Characteristic angle	DPHxPDOC	$-179 \dots 180^\circ$	1
Operating curve type ¹⁾	DPHLPDOC	Definite or inverse time Curve type: 1, 2, 3, 4, 5, 6, 7, 8, 9, 10, 11, 12, 13, 14, 15, 17, 18, 19	
	DPHHPDOC	Definite or inverse time Curve type: 1, 3, 5, 9, 10, 12, 15, 17	

1) For further reference, see the Operating characteristics table

—
Table 33. Non-directional ground-fault protection (EFxPTOC)

Characteristic		Value		
Operation accuracy	EFHPTOC	$\pm 1.5\%$ of set value or $\pm 0.002 \times I_n$ (at currents in the range of $0.1 \dots 10 \times I_n$) $\pm 5.0\%$ of the set value (at currents in the range of $10 \dots 40 \times I_n$)		
Start time ¹⁾²⁾		Minimum	Typical	Maximum
	EFHPTOC and EFLPTOC: $I_{Fault} = 2 \times \text{set Start value}$	23 ms	26 ms	29 ms
Reset time		Typically 40 ms		
Reset ratio		Typically 0.96		
Retardation time		<30 ms		
Operate time accuracy in definite time mode		$\pm 1.0\%$ of the set value or ± 20 ms		
Operate time accuracy in inverse time mode		$\pm 5.0\%$ of the theoretical value or ± 20 ms ³⁾		
Suppression of harmonics		RMS: No suppression DFT: -50 dB at $f = n \times f_n$, where $n = 2, 3, 4, 5, \dots$ Peak-to-Peak: No suppression		

1) Measurement mode and Pol quantity = default, current before fault = $0.0 \times I_n$, voltage before fault = $1.0 \times U_n$, $f_n = 50$ Hz, fault current in one phase with nominal frequency injected from random phase angle, results based on statistical distribution of 1000 measurements

2) Includes the delay of the signal output contact

3) Maximum Start value = $2.5 \times I_n$, Start value multiples in range of 1.5...20

—
Table 34. Non-directional ground-fault protection (EFxPTOC) main settings

	Function	Value (Range)	Step
Start value	EFHPTOC	$0.10 \dots 40.00 \times I_n$	0.01
Time multiplier	EFHPTOC	0.05...15.00	0.01
Operate delay time	EFHPTOC	40...200000 ms	10
Operating curve type ¹⁾	EFHPTOC	Definite or inverse time Curve type: 1, 3, 5, 9, 10, 12, 15, 17	

1) For further reference, see the Operating characteristics table

Table 35. Directional ground-fault protection (DEFxPDEF)

Characteristic	Value		
Operation accuracy	Depending on the frequency of the measured current: $f_n \pm 2$ Hz		
	DEFLPDEF	Current: $\pm 1.5\%$ of the set value or $\pm 0.002 \times I_n$ Voltage $\pm 1.5\%$ of the set value or $\pm 0.002 \times U_n$ Phase angle: $\pm 2^\circ$	
	DEFHPDEF	Current: $\pm 1.5\%$ of the set value or $\pm 0.002 \times I_n$ (at currents in the range of $0.1 \dots 10 \times I_n$) $\pm 5.0\%$ of the set value (at currents in the range of $10 \dots 40 \times I_n$) Voltage: $\pm 1.5\%$ of the set value or $\pm 0.002 \times U_n$ Phase angle: $\pm 2^\circ$	
Start time ¹⁾²⁾		Minimum	Typical
	DEFHPDEF		Maximum
	$I_{Fault} = 2 \times \text{set Start value}$	42 ms	46 ms
	DEFLPDEF	58 ms	62 ms
	$I_{Fault} = 2 \times \text{set Start value}$		66 ms
Reset time	Typically 40 ms		
Reset ratio	Typically 0.96		
Retardation time	<30 ms		
Operate time accuracy in definite time mode	$\pm 1.0\%$ of the set value or ± 20 ms		
Operate time accuracy in inverse time mode	$\pm 5.0\%$ of the theoretical value or ± 20 ms ³⁾		
Suppression of harmonics	RMS: No suppression DFT: -50 dB at $f = n \times f_n$, where $n = 2, 3, 4, 5, \dots$ Peak-to-Peak: No suppression		

1) Set Operate delay time = 0.06 s, Operate curve type = IEC definite time, Measurement mode = default (depends on stage), current before fault = $0.0 \times I_n$, $f_n = 50$ Hz, ground-fault current with nominal frequency injected from random phase angle, results based on statistical distribution of 1000 measurements

2) Includes the delay of the signal output contact

3) Maximum Start value = $2.5 \times I_n$, Start value multiples in range of 1.5...20

—
Table 36. Directional ground-fault protection (DEFxPDEF) main settings

Parameter	Function	Value (Range)	Step
Start value	DEFLPDEF	$0.010 \dots 5.000 \times I_n$	0.005
	DEFHPDEF	$0.10 \dots 40.00 \times I_n$	0.01
Directional mode	DEFLPDEF and DEFHPDEF	1 = Non-directional 2 = Forward 3 = Reverse	-
Time multiplier	DEFLPDEF	0.05...15.00	0.01
	DEFHPDEF	0.05...15.00	0.01
Operate delay time	DEFLPDEF	50...200000 ms	10
	DEFHPDEF	40...200000 ms	10
Operating curve type ¹⁾	DEFLPDEF	Definite or inverse time Curve type: 1, 2, 3, 4, 5, 6, 7, 8, 9, 10, 11, 12, 13, 14, 15, 17, 18, 19	
	DEFHPDEF	Definite or inverse time Curve type: 1, 3, 5, 15, 17	
Operation mode	DEFxPDEF	1 = Phase angle 2 = $I_o \sin$ 3 = $I_o \cos$ 4 = Phase angle 80 5 = Phase angle 88	

1) For further reference, see the Operating characteristics table

—
Table 37. Admittance-based ground-fault protection (EFPADM)

Characteristic	Value		
Operation accuracy ¹⁾	At the frequency $f = f_n$ $\pm 1.0\%$ or ± 0.01 mS (In range of 0.5... 100 mS)		
Start time ²⁾	Minimum	Typical	Maximum
	56 ms	60 ms	64 ms
Reset time	40 ms		
Operate time accuracy	$\pm 1.0\%$ of the set value of ± 20 ms		
Suppression of harmonics	-50 dB at $f = n \times f_n$, where $n = 2, 3, 4, 5, \dots$		

1) $U_o = 1.0 \times U_n$

2) Includes the delay of the signal output contact, results based on statistical distribution of 1000 measurements

—
Table 38. Admittance-based ground-fault protection (EFPADM) main settings

Parameter	Function	Value (Range)	Step
Voltage start value	EFPADM	$0.01 \dots 2.000 \times U_n$	0.01
Directional mode	EFPADM	1 = Non-directional 2 = Forward 3 = Reverse	-
Operation mode	EFPADM	1 = Yo 2 = Go 3 = Bo 4 = Yo, Go 5 = Yo, Bo 6 = Go, Bo 7 = Yo, Go, Bo	-
Operate delay time	EFPADM	60...200000 ms	10
Circle radius	EFPADM	0.05...500.00 mS	0.01
Circle conductance	EFPADM	-500.00...500.00 mS	0.01
Circle susceptance	EFPADM	-500.00...500.00 mS	0.01
Conductance forward	EFPADM	-500.00...500.00 mS	0.01
Conductance reverse	EFPADM	-500.00...500.00 mS	0.01
Susceptance forward	EFPADM	-500.00...500.00 mS	0.01
Susceptance reverse	EFPADM	-500.00...500.00 mS	0.01
Conductance tilt Ang	EFPADM	-30...30°	1
Susceptance tilt Ang	EFPADM	-30...30°	1

—
Table 39. Wattmetric-based ground-fault protection (WPWDE)

Characteristic	Value
Operation accuracy ¹⁾	Depending on the frequency of the measured current: $f_n \pm 2$ Hz Current and voltage: $\pm 1.5\%$ of the set value or $\pm 0.002 \times I_n$ Power: $\pm 3\%$ of the set value or $\pm 0.002 \times P_n$
Start time ¹⁾²⁾	Typically 63 ms
Reset time	Typically 40 ms
Reset ratio	Typically 0.96
Operate time accuracy in definite time mode	$\pm 1.0\%$ of the set value or ± 20 ms
Operate time accuracy in IDMT mode	$\pm 5.0\%$ of the set value or ± 20 ms
Suppression of harmonics	-50 dB at $f = n \times f_n$, where $n = 2, 3, 4, 5, \dots$

1) I_0 varied during the test, $U_0 = 1.0 \times U_n$ = phase to ground voltage during ground fault in compensated or un-grounded network, the residual power value before fault = 0.0 pu, $f_n = 50$ Hz, results based on statistical distribution of 1000 measurements

2) Includes the delay of the signal output contact

—
Table 40. Wattmetric-based ground-fault protection (WPWDE) main settings

Parameter	Function	Value (Range)	Step
Directional mode	WPWDE	2 = Forward 3 = Reverse	-
Current start value	WPWDE	$0.010 \dots 5.000 \times I_n$	0.001
Voltage start value	WPWDE	$0.010 \dots 1.000 \times U_n$	0.001
Power start value	WPWDE	$0.003 \dots 1.000 \times P_n$	0.001
Reference power	WPWDE	$0.050 \dots 1.000 \times P_n$	0.001
Characteristic angle	WPWDE	-179...180°	1
Time multiplier	WPWDE	0.05...2.00	0.01
Operating curve type ¹⁾	WPWDE	Definite or inverse time Curve type: 5, 15, 20	
Operate delay time	WPWDE	60...200000 ms	10
Min operate current	WPWDE	$0.010 \dots 1.000 \times I_n$	0.001
Min operate voltage	WPWDE	$0.01 \dots 1.00 \times U_n$	0.01

1) For further reference, see the Operating characteristics table

—
Table 41. Transient/intermittent ground-fault protection (INTRPTEF)

Characteristic	Value
Operation accuracy (U _o criteria with transient protection)	Depending on the frequency of the measured current: $f_n \pm 2$ Hz $\pm 1.5\%$ of the set value or $\pm 0.002 \times U_o$
Operate time accuracy	$\pm 1.0\%$ of the set value or ± 20 ms
Suppression of harmonics	DFT: -50 dB at $f = n \times f_n$, where $n = 2, 3, 4, 5$

—
Table 42. Transient/intermittent ground-fault protection (INTRPTEF) main settings

Parameter	Function	Value (Range)	Step
Directional mode	INTRPTEF	1 = Non-directional 2 = Forward 3 = Reverse	-
Operate delay time	INTRPTEF	40...1200000 ms	10
Voltage start value	INTRPTEF	$0.05 \dots 0.50 \times U_n$	0.01
Operation mode		1 = Intermittent EF 2 = Transient EF	-
Peak counter limit	INTRPTEF	2...20	1
Min operate current	INTRPTEF	$0.01 \dots 1.00 \times I_n$	0.01

Table 43. Harmonics-based ground-fault protection (HAEFPTOC)

Characteristic	Value
Operation accuracy	Depending on the frequency of the measured current: $f_n \pm 2$ Hz $\pm 5\%$ of the set value or $\pm 0.004 \times I_n$
Start time ¹⁾²⁾	Typically 77 ms
Reset time	Typically 40 ms
Reset ratio	Typically 0.96
Retardation time	<35 ms
Operate time accuracy in definite time mode	$\pm 1.0\%$ of the set value or ± 20 ms
Operate time accuracy in IDMT mode ³⁾	$\pm 5.0\%$ of the set value or ± 20 ms
Suppression of harmonics	-50 dB at $f = f_n$, -3 dB at $f = 13 \times f_n$

1) Fundamental frequency current = $1.0 \times I_n$, harmonics current before fault = $0.0 \times I_n$, harmonics fault current $2.0 \times$ Start value, results based on statistical distribution of 1000 measurements

2) Includes the delay of the signal output contact

3) Maximum Start value = $2.5 \times I_n$, Start value multiples in range of 2...20

Table 44. Harmonics-based ground-fault protection (HAEFPTOC) main settings

Parameter	Function	Value (Range)	Step
Start value	HAEFPTOC	$0.05 \dots 5.00 \times I_n$	0.01
Time multiplier	HAEFPTOC	0.05...15.00	0.01
Operate delay time	HAEFPTOC	100...200000 ms	10
Operating curve type ¹⁾	HAEFPTOC	Definite or inverse time Curve type: 1, 2, 3, 4, 5, 6, 7, 8, 9, 10, 11, 12, 13, 14, 15, 17, 18, 19	
Minimum operate time	HAEFPTOC	100...200000 ms	10

1) For further reference, see the Operation characteristics table

Table 45. Negative-sequence overcurrent protection (NSPTOC)

Characteristic	Value
Operation accuracy	Depending on the frequency of the measured current: f_n $\pm 1.5\%$ of the set value or $\pm 0.002 \times I_n$
Start time ¹⁾²⁾	Minimum Typical Maximum
	$I_{Fault} = 2 \times$ set Start value 23 ms 26 ms 28 ms
	$I_{Fault} = 10 \times$ set Start value 15 ms 18 ms 20 ms
Reset time	Typically 40 ms
Reset ratio	Typically 0.96
Retardation time	<35 ms
Operate time accuracy in definite time mode	$\pm 1.0\%$ of the set value or ± 20 ms ³⁾
Operate time accuracy in inverse time mode	$\pm 5.0\%$ of the theoretical value or ± 20 ms ³⁾
Suppression of harmonics	DFT: -50 dB at $f = n \times f_n$, where $n = 2, 3, 4, 5, \dots$

1) Negative sequence current before fault = 0.0, $f_n = 50$ Hz, results based on statistical distribution of 1000 measurements

2) Includes the delay of the signal output contact

3) Maximum Start value = $2.5 \times I_n$, Start value multiples in range of 1.5...20

—
Table 46. Negative-sequence overcurrent protection (NSPTOC) main settings

Parameter	Function	Value (Range)	Step
Start value	NSPTOC	$0.01...5.00 \times I_n$	0.01
Time multiplier	NSPTOC	0.05...15.00	0.01
Operate delay time	NSPTOC	40...200000 ms	10
Operating curve type ¹⁾	NSPTOC	Definite or inverse time Curve type: 1, 2, 3, 4, 5, 6, 7, 8, 9, 10, 11, 12, 13, 14, 15, 17, 18, 19	

1) For further reference, see the Operation characteristics table

—
Table 47. Phase discontinuity protection (PDNSPTOC)

Characteristic	Value
Operation accuracy	Depending on the frequency of the measured current: $f_n \pm 2$ Hz $\pm 2\%$ of the set value
Start time	<70 ms
Reset time	Typically 40 ms
Reset ratio	Typically 0.96
Retardation time	<35 ms
Operate time accuracy in definite time mode	$\pm 1.0\%$ of the set value or ± 20 ms
Suppression of harmonics	DFT: -50 dB at $f = n \times f_n$, where $n = 2, 3, 4, 5, \dots$

—
Table 48. Phase discontinuity protection (PDNSPTOC) main settings

Parameter	Function	Value (Range)	Step
Start value	PDNSPTOC	10...100%	1
Operate delay time	PDNSPTOC	100...30000 ms	1
Min phase current	PDNSPTOC	$0.05...0.30 \times I_n$	0.01

—
Table 49. Residual overvoltage protection (ROVPTOV)

Characteristic	Value
Operation accuracy	Depending on the frequency of the measured voltage: $f_n \pm 2$ Hz $\pm 1.5\%$ of the set value or $\pm 0.002 \times U_n$
Start time ¹⁾²⁾	Minimum Typical Maximum $U_{Fault} = 2 \times \text{set Start value}$ 48 ms 51 ms 54 ms
Reset time	Typically 40 ms
Reset ratio	Typically 0.96
Retardation time	<35 ms
Operate time accuracy in definite time mode	$\pm 1.0\%$ of the set value or ± 20 ms
Suppression of harmonics	DFT: -50 dB at $f = n \times f_n$, where $n = 2, 3, 4, 5, \dots$

1) Residual voltage before fault = $0.0 \times U_n$, $f_n = 50$ Hz, residual voltage with nominal frequency injected from random phase angle, results based on statistical distribution of 1000 measurements

2) Includes the delay of the signal output contact

Table 50. Residual overvoltage protection (ROVPTOV) main settings

Parameter	Function	Value (Range)	Step
Start value	ROVPTOV	$0.010...1.000 \times U_n$	0.001
Operate delay time	ROVPTOV	40...300000 ms	1

1) For further reference, see the Operation characteristics table

Table 51. Three-phase undervoltage protection (PHPTUV)

Characteristic	Value
Operation accuracy	Depending on the frequency of the voltage measured: $f_n \pm 2$ Hz $\pm 1.5\%$ of the set value or $\pm 0.002 \times U_n$
Start time ¹⁾²⁾	Minimum Typical Maximum
UFault = $0.9 \times$ set Start value	62 ms 66 ms 70 ms
Reset time	Typically 40 ms
Reset ratio	Depends on the set Relative hysteresis
Retardation time	<35 ms
Operate time accuracy in definite time mode	$\pm 1.0\%$ of the set value or ± 20 ms
Operate time accuracy in inverse time mode	$\pm 5.0\%$ of the theoretical value or ± 20 ms ³⁾
Suppression of harmonics	DFT: -50 dB at $f = n \times f_n$, where $n = 2, 3, 4, 5, \dots$

1) Start value = $1.0 \times U_n$, Voltage before fault = $1.1 \times U_n$, $f_n = 50$ Hz, undervoltage in one phase-to-phase with nominal frequency injected from random phase angle, results based on statistical distribution of 1000 measurements

2) Includes the delay of the signal output contact

3) Minimum Start value = 0.50, Start value multiples in range of 0.90...0.20

Table 52. Three-phase undervoltage protection (PHPTUV) main settings

Characteristic	Function	Value	Step
Start value	PHPTUV	$0.05...1.20 \times U_n$	0.01
Time multiplier	PHPTUV	0.05...15.00	0.01
Operate delay time	PHPTUV	60...300000 ms	10
Operating curve type ¹⁾	PHPTUV	Definite or inverse time Curve type: 5, 15, 21, 22, 23	

1) For further reference, see the Operation characteristics table

Table 53. Three-phase overvoltage protection (PHPTOV)

Characteristic	Value
Operation accuracy	Depending on the frequency of the measured voltage: $f_n \pm 2$ Hz $\pm 1.5\%$ of the set value or $\pm 0.002 \times U_n$
Start time ¹⁾²⁾	Minimum Typical Maximum
$U_{Fault} = 1.1 \times$ set Start value	23 ms 27 ms 31 ms
Reset time	Typically 40 ms
Reset ratio	Depends on the set Relative hysteresis
Retardation time	<35 ms
Operate time accuracy in definite time mode	$\pm 1.0\%$ of the set value or ± 20 ms
Operate time accuracy in inverse time mode	$\pm 5.0\%$ of the theoretical value or ± 20 ms ³⁾
Suppression of harmonics	DFT: -50 dB at $f = n \times f_n$, where $n = 2, 3, 4, 5, \dots$

1) Start value = $1.0 \times U_n$, Voltage before fault = $0.9 \times U_n$, $f_n = 50$ Hz, overvoltage in one phase-to-phase with nominal frequency injected from random phase angle, results based on statistical distribution of 1000 measurements

2) Includes the delay of the signal output contact

3) Maximum Start value = $1.20 \times U_n$, Start value multiples in range of 1.10...2.00

Table 54. Three-phase overvoltage protection (PHPTOV) main settings

Parameter	Function	Value (Range)	Step
Start value	PHPTOV	0.05...1.60 × U _n	0.01
Time multiplier	PHPTOV	0.05...15.00	0.01
Operate delay time	PHPTOV	40...300000 ms	10
Operating curve type ¹⁾	PHPTOV	Definite or inverse time Curve type: 5, 15, 17, 18, 19, 20	

1) For further reference, see the Operation characteristics table

Table 55. Positive-sequence undervoltage protection (PSPTUV)

Characteristic	Value
Operation accuracy	Depending on the frequency of the measured voltage: f _n ±2 Hz ±1.5% of the set value or ±0.002 × U _n
Start time ¹⁾²⁾	Minimum Typical Maximum
U _{Fault} = 0.99 × set Start value	52 ms 55 ms 58 ms
U _{Fault} = 0.9 × set Start value	44 ms 47 ms 50 ms
Reset time	Typically 40 ms
Reset ratio	Depends on the set Relative hysteresis
Retardation time	<35 ms
Operate time accuracy in definite time mode	±1.0% of the set value or ±20 ms
Suppression of harmonics	DFT: -50 dB at f = n × f _n , where n = 2, 3, 4, 5,...

1) Start value = 1.0 × U_n, positive-sequence voltage before fault = 1.1 × U_n, f_n = 50 Hz, positive sequence undervoltage with nominal frequency injected from random phase angle, results based on statistical distribution of 1000 measurements

2) Includes the delay of the signal output contact

Table 56. Positive-sequence undervoltage protection (PSPTUV) main settings

Parameter	Function	Value (Range)	Step
Start value	PSPTUV	0.010...1.200 × U _n	0.001
Operate delay time	PSPTUV	40...120000 ms	10
Voltage block value	PSPTUV	0.01...1.00 × U _n	0.01

Table 57. Negative-sequence overvoltage protection (NSPTOV)

Characteristic	Value
Operation accuracy	Depending on the frequency of the voltage measured: f _n ±1.5% of the set value or ±0.002 × U _n
Start time ¹⁾²⁾	Minimum Typical Maximum
U _{Fault} = 1.1 × set Start value	33 ms 35 ms 37 ms
U _{Fault} = 2.0 × set Start value	24 ms 26 ms 28 ms
Reset time	Typically 40 ms
Reset ratio	Typically 0.96
Retardation time	<35 ms
Operate time accuracy in definite time mode	±1.0% of the set value or ±20 ms
Suppression of harmonics	DFT: -50 dB at f = n × f _n , where n = 2, 3, 4, 5,...

1) Negative-sequence voltage before fault = 0.0 × U_n, f_n = 50 Hz, negative-sequence overvoltage with nominal frequency injected from random phase angle, results based on statistical distribution of 1000 measurements

2) Includes the delay of the signal output contact

—
Table 58. Negative-sequence overvoltage protection (NSPTOV) main settings

Parameter	Function	Value (Range)	Step
Start value	NSPTOV	$0.010...1.000 \times U_n$	0.001
Operate delay time	NSPTOV	40...120000 ms	1

—
Table 59. Frequency protection (FRPFRQ)

Characteristic		Value
Operation accuracy	f>/f<	±5 mHz
	df/dt	±50 mHz/s (in range df/dt < 5 Hz/s) ±2.0% of the set value (in range 5 Hz/s < df/dt < 15 Hz/s)
Start time	f>/f<	<80 ms
	df/dt	<120 ms
Reset time		<150 ms
Operate time accuracy		±1.0% of the set value or ±30 ms

—
Table 60. Frequency protection (FRPFRQ) main settings

Parameter	Function	Value (Range)	Step
Operation mode	FRPFRQ	1 = Freq<	-
		2 = Freq>	
		3 = df/dt	
		4 = Freq< + df/dt	
		5 = Freq> + df/dt	
		6 = Freq< OR df/dt	
		7 = Freq> OR df/dt	
Start value Freq>	FRPFRQ	$0.9000...1.2000 \times f_n$	0.0001
Start value Freq<	FRPFRQ	$0.8000...1.1000 \times f_n$	0.0001
Start value df/dt	FRPFRQ	$-0.2000...0.2000 \times f_n/s$	0.005
Operate Tm Freq	FRPFRQ	80...200000 ms	10
Operate Tm df/dt	FRPFRQ	120...200000 ms	10

—
Table 61. Three-phase thermal protection for feeders, cables and distribution transformers (T1PTTR)

Characteristic	Value
Operation accuracy	Depending on the frequency of the measured current: $f_n \pm 2$ Hz Current measurement: ±1.5% of the set value or $\pm 0.002 \times I_n$ (at currents in the range of $0.01...4.00 \times I_n$)
Operate time accuracy ¹⁾	±2.0% of the theoretical value or ±0.50 s

1) Overload current > 1.2 × Operate level temperature

—
Table 62. Three-phase thermal protection for feeders, cables and distribution transformers (T1PTTR) main settings

Parameter	Function	Value (Range)	Step
Env temperature Set	T1PTTR	-50...100°C	1
Current reference	T1PTTR	0.05...4.00 × I _n	0.01
Temperature rise	T1PTTR	0.0...200.0°C	0.1
Time constant	T1PTTR	60...60000 s	1
Maximum temperature	T1PTTR	20.0...200.0°C	0.1
Alarm value	T1PTTR	20.0...150.0°C	0.1
Reclose temperature	T1PTTR	20.0...150.0°C	0.1
Current multiplier	T1PTTR	1...5	1
Initial temperature	T1PTTR	-50.0...100.0°C	0.1

—
Table 63. Three-phase thermal overload protection, two time constants (T2PTTR)

Characteristic	Value
Operation accuracy	Depending on the frequency of the measured current: f _n ±2 Hz Current measurement: ±1.5% of the set value or ±0.002 × I _n (at currents in the range of 0.01...4.00 × I _n)
Operate time accuracy ¹⁾	±2.0% of the theoretical value or ±0.50 s

1) Overload current > 1.2 × Operate level temperature

—
Table 64. Three-phase thermal overload protection, two time constants (T2PTTR) main settings

Parameter	Function	Value (Range)	Step
Temperature rise	T2PTTR	0.0...200.0°C	0.1
Max temperature	T2PTTR	0.0...200.0°C	0.1
Operate temperature	T2PTTR	80.0...120.0%	0.1
Short time constant	T2PTTR	6...60000 s	1
Weighting factor p	T2PTTR	0.00...1.00	0.01
Current reference	T2PTTR	0.05...4.00 × I _n	0.01
Operation	T2PTTR	1 = on 5 = off	-

—
Table 65. Binary signal transfer (BSTGGIO)

Characteristic	Value	Step
Signalling delay	Fiber optic link <5 ms	0.05
CB fault delay	Galvanic pilot wire link <10 ms	10

—
Table 66. Circuit breaker failure protection (CCBRBRF)

Characteristic	Value
Operation accuracy	Depending on the frequency of the measured current: f _n ±2 Hz ±1.5% of the set value or ±0.002 × I _n
Operate time accuracy	±1.0% of the set value or ±20 ms
Reset time	Typically 40 ms
Retardation time	<20 ms

—
Table 67. Circuit breaker failure protection (CCBRBRF) main settings

Parameter	Function	Value (Range)	Step
Current value	CCBRBRF	0.05...2.00 × I _n	0.05
Current value Res	CCBRBRF	0.05...2.00 × I _n	0.05
CB failure mode	CCBRBRF	1 = Current 2 = Breaker status 3 = Both	-
CB fail trip mode	CCBRBRF	1 = Off 2 = Without check 3 = Current check	-
Retrip time	CCBRBRF	0...60000 ms	10
CB failure delay	CCBRBRF	0...60000 ms	10
CB fault delay	CCBRBRF	0...60000 ms	10

—
Table 68. Three-phase inrush detector (INRPHAR)

Characteristic	Value
Operation accuracy	At the frequency $f = f_n$ Current measurement: ±1.5% of the set value or $\pm 0.002 \times I_n$ Ratio I _{2f} /I _{1f} measurement: ±5.0% of the set value
Reset time	+35 ms / -0 ms
Reset ratio	Typically 0.96
Operate time accuracy	+35 ms / -0 ms

—
Table 69. Three-phase inrush detector (INRPHAR) main settings

Parameter	Function	Value (Range)	Step
Start value	INRPHAR	5...100%	1
Operate delay time	INRPHAR	20...60000 ms	1

—
Table 70. Switch onto fault (CBPSOF)

Characteristic	Value
Operate time accuracy	±1.0% of the set value or ±20 ms

—
Table 71. TSwitch onto fault (CBPSOF) main settings

Parameter	Function	Value (Range)	Step
SOTF reset time	CBPSOF	0...60000 ms	1

—
Table 72. Multipurpose protection (MAPGAPC)

Characteristic	Value
Operate time accuracy	±1.0% of the set value or ±20 ms

—
Table 73. Multipurpose protection (MAPGAPC) main settings

Parameter	Function	Value (Range)	Step
Start value	MAPGAPC	-10000.0...10000.0	0.01
Operate delay time	MAPGAPC	0...200000 ms	0.01
Operation mode	MAPGAPC	1 = Over 2 = Under	-

—
Table 74. Fault locator (SCEFRFLO)

Characteristic	Value
Measurement accuracy	At the frequency $f = f_n$ Impedance: $\pm 2.5\%$ or $\pm 0.25 \Omega$ Distance: $\pm 2.5\%$ or ± 0.16 km/0.1 mile XC0F_CALC: $\pm 2.5\%$ or $\pm 50 \Omega$ IFLT_PER_ILD: $\pm 5\%$ or ± 0.05

—
Table 75. Fault locator (SCEFRFLO) main settings

Parameter	Function	Value (Range)	Step
Z Max phase load	SCEFRFLO	1.0...10000.00 Ω	0.1
Ph leakage Ris	SCEFRFLO	20...1000000 Ω	1
Ph capacitive React	SCEFRFLO	10...1000000 Ω	1
R1 line section A	SCEFRFLO	0.000...1000.000 Ω /pu	0.001
X1 line section A	SCEFRFLO	0.000...1000.000 Ω /pu	0.001
R0 line section A	SCEFRFLO	0.000...1000.000 Ω /pu	0.001
X0 line section A	SCEFRFLO	0.000...1000.000 Ω /pu	0.001
Line Len section A	SCEFRFLO	0.000...1000.000 pu	0.001

—
Table 76. Line differential protection with in-zone power transformer (LNPLDF)

Characteristic	Value
Operation accuracy ¹⁾	Depending on the frequency of the current measured: $f_n \pm 2$ Hz Low stage $\pm 2.5\%$ of the set value High stage $\pm 2.5\%$ of the set value
High stage, operate time ²⁾³⁾	Minimum Typical Maximum 22 ms 25 ms 29 ms
Reset time	<40 ms
Reset ratio	Typically 0.96
Retardation time (Low stage)	<40 ms
Operate time accuracy in definite time mode	$\pm 1.0\%$ of the set value or ± 20 ms
Operate time accuracy in inverse time mode	$\pm 5.0\%$ of the set value or ± 20 ms 4)

1) With the symmetrical communication channel (as when using dedicated fiber optic).

2) Without additional delay in the communication channel (as when using dedicated fiber optic).

3) Including the delay of the output contact. When differential current = $2 \times$ High operate value and $f_n = 50$ Hz with galvanic pilot wire link + 5 ms.

4) Low operate value multiples in range of 1.5...20.

—
Table 77. Line differential protection with in-zone power transformer (LNPLDF) main settings

Parameter	Function	Value (Range)	Step
Low operate value	LNPLDF	10...200 % I_n	1
High operate value	LNPLDF	200...4000 % I_n	1
Start value 2.H	LNPLDF	10...50 %	1
Time multiplier	LNPLDF	0.05...15.00	0.01
Operate curve type	LNPLDF	1=ANSI Ext. inv. 3=ANSI Norm. inv. 5=ANSI Def. Time 9=IEC Norm. inv. 10=IEC Very inv. 12=IEC Ext. inv. 15=IEC Def. Time	-
Operate delay time	LNPLDF	45...200000 ms	1
CT ratio correction	LNPLDF	0.200...5.000	0.001

—
Table 78. High-impedance fault detection (PHIZ) main settings

Parameter	Function	Value (Range)	Step
Security Level	PHIZ	1...10	1
System type	PHIZ	1 = Grounded 2 = Ungrounded	-

—
Table 79. Operation characteristics

Characteristic	Value
Operating curve type	1 = ANSI Ext. inv.
	2 = ANSI Very. inv.
	3 = ANSI Norm. inv.
	4 = ANSI Mod inv.
	5 = ANSI Def. Time
	6 = L.T.E. inv.
	7 = L.T.V. inv.
	8 = L.T. inv.
	9 = IEC Norm. inv.
	10 = IEC Very inv.
	11 = IEC inv.
	12 = IEC Ext. inv.
	13 = IEC S.T. inv.
	14 = IEC L.T. inv.
	15 = IEC Def. Time
	17 = Programmable
	18 = RI type
	19 = RD type
	Operating curve type (voltage protection)
15 = IEC Def. Time	
17 = Inv. Curve A	
18 = Inv. Curve B	
19 = Inv. Curve C	
20 = Programmable	
21 = Inv. Curve A	
22 = Inv. Curve B	
23 = Programmable	

Power quality functions

—
Table 80. Three-phase underimpedance protection (UZPDIS) main settings

Characteristic	Value
Operation accuracy	±1.5% of the set value or ±0.2% of reference voltage
Reset ratio	Typically 0.96 (Swell), 1.04 (Dip, Interruption)

—
Table 81. Voltage variation (PHQVVR) main settings

Parameter	Function	Value (Range)	Step
Voltage dip set 1	PHQVVR	10.0...100.0%	0.1
Voltage dip set 2	PHQVVR	10.0...100.0%	0.1
Voltage dip set 3	PHQVVR	10.0...100.0%	0.1
Voltage swell set 1	PHQVVR	100.0...140.0%	0.1
Voltage swell set 2	PHQVVR	100.0...140.0%	0.1
Voltage swell set 3	PHQVVR	100.0...140.0%	0.1
Voltage Int set	PHQVVR	0.0...100.0%	0.1
VVa Dur Max	PHQVVR	100...3600000 ms	100

—
Table 82. Voltage unbalance (VSQVUB)

Characteristic	Value
Operation accuracy	±1.5% of the set value or $\pm 0.002 \times U_n$
Reset ratio	Typically 0.96

—
Table 83. Voltage unbalance (VSQVUB) main settings

Parameter	Function	Value (Range)	Step
Operation	VSQVUB	1 = on 5 = off	-
Unb detection method	VSQVUB	1 = Neg Seq 2 = Zero Seq 3 = Neg to Pos Seq 4 = Zero to Pos Seq 5 = Ph vectors Comp	

—
Table 84. Autoreclosing (DARREC)

Characteristic	Value
Operate time accuracy	$\pm 1.0\%$ of the set value or ± 20 ms

—
Table 85. Synchronism and energizing check (SECRSYN)

Parameter	Value (Range)
Operation accuracy	Depending on the frequency of the voltage measured: $f_n \pm 1$ Hz Voltage: $\pm 3.0\%$ of the set value or $\pm 0.01 \times U_n$ Frequency: ± 10 mHz Phase angle: $\pm 3^\circ$
Reset time	<50 ms
Reset ratio	Typically 0.96
Operate time accuracy in definite time mode	$\pm 1.0\%$ of the set value or ± 20 ms

—
Table 86. Synchronism and energizing check (SECRSYN) main settings

Parameter	Function	Value (Range)	Step
Live dead mode	SECRSYN	-1 = Off 1 = Both Dead 2 = Live L, Dead B 3 = Dead L, Live B 4 = Dead Bus, L Any 5 = Dead L, Bus Any 6 = One Live, Dead 7 = Not Both Live	-
Difference voltage	SECRSYN	$0.01 \dots 0.50 \times U_n$	0.01
Difference frequency	SECRSYN	$0.001 \dots 0.100 \times f_n$	0.001
Difference angle	SECRSYN	$5 \dots 90^\circ$	1
Synchrocheck mode	SECRSYN	1 = Off 2 = Synchronous 3 = Asynchronous	-
Dead line value	SECRSYN		0.1
Live line value	SECRSYN		0.1
Max energizing V	SECRSYN		0.01
Control mode	SECRSYN	1 = Continuous 2 = Command	-
Close pulse	SECRSYN	200...60000 ms	10
Phase shift	SECRSYN	$-180 \dots 180^\circ$	1
Minimum Syn time	SECRSYN	0...60000 ms	10
Maximum Syn time	SECRSYN	100...6000000 ms	10
Energizing time	SECRSYN	100...60000 ms	10
Closing time of CB	SECRSYN	40...250 ms	10

Condition monitoring and supervision functions

Table 87. Circuit-breaker condition monitoring (SSCBR)

Characteristic	Value
Current measuring accuracy	$\pm 1.5\%$ or $\pm 0.002 \times I_n$ (at currents in the range of $0.1 \dots 10 \times I_n$) $\pm 5.0\%$ (at currents in the range of $10 \dots 40 \times I_n$)
Operate time accuracy	$\pm 1.0\%$ of the set value or ± 20 ms
Travelling time measurement	+10 ms / -0 ms

Table 88. Current circuit supervision (CCSPVC)

Characteristic	Value
Operate time ¹⁾	<30 ms

¹⁾ Including the delay of the output contact

Table 89. Current circuit supervision (CCSPVC) main settings

Parameter	Function	Value (Range)	Step
Start value	CCSPVC	$0.05 \dots 0.20 \times I_n$	0.01
Max operate current	CCSPVC	$1.00 \dots 5.00 \times I_n$	0.01

Table 90. Fuse failure supervision (SEQSPVC)

Parameter	Function	Value (Range)	Step
Operate time ¹⁾	NPS function	$U_{\text{Fault}} = 1.1 \times \text{set Neg Seq voltage}$ Lev	<33 ms
		$U_{\text{Fault}} = 5.0 \times \text{set Neg Seq voltage}$ Lev	<18 ms
	Delta function	$\Delta U = 1.1 \times \text{set Voltage change rate}$	<30 ms
		$\Delta U = 2.0 \times \text{set Voltage change rate}$	<24 ms

¹⁾ Includes the delay of the signal output contact, $f_n = 50$ Hz, fault voltage with nominal frequency injected from random phase angle, results based on statistical distribution of 1000 measurements

Table 91. Runtime counter for machines and devices (MDSOPT)

Characteristic	Value
Motor runtime measurement accuracy ¹⁾	$\pm 0.5\%$

¹⁾ Of the reading, for a stand-alone relay, without time synchronization

Measurement functions

—
Table 92. Three-phase current measurement (CMMXU)

Characteristic	Value
Operation accuracy	Depending on the frequency of the measured current: $f_n \pm 2$ Hz $\pm 0.5\%$ or $\pm 0.002 \times I_n$ (at currents in the range of $0.01 \dots 4.00 \times I_n$)
Suppression of harmonics	DFT: -50 dB at $f = n \times f_n$, where $n = 2, 3, 4, 5, \dots$ RMS: No suppression

—
Table 93. Sequence current measurement (CSMSQI)

Characteristic	Value
Operation accuracy	Depending on the frequency of the measured current: $f/f_n = \pm 2$ Hz $\pm 1.0\%$ or $\pm 0.002 \times I_n$ at currents in the range of $0.01 \dots 4.00 \times I_n$
Suppression of harmonics	DFT: -50 dB at $f = n \times f_n$, where $n = 2, 3, 4, 5, \dots$

—
Table 94. Residual current measurement (RESCMMXU)

Characteristic	Value
Operation accuracy	Depending on the frequency of the measured current: $f/f_n = \pm 2$ Hz $\pm 0.5\%$ or $\pm 0.002 \times I_n$ at currents in the range of $0.01 \dots 4.00 \times I_n$
Suppression of harmonics	DFT: -50 dB at $f = n \times f_n$, where $n = 2, 3, 4, 5, \dots$ RMS: No suppression

—
Table 95. Three-phase voltage measurement (VMMXU)

Characteristic	Value
Operation accuracy	Depending on the frequency of the voltage measured: $f_n \pm 2$ Hz At voltages in range $0.01 \dots 1.15 \times U_n$ $\pm 0.5\%$ or $\pm 0.002 \times U_n$
Suppression of harmonics	DFT: -50 dB at $f = n \times f_n$, where $n = 2, 3, 4, 5, \dots$ RMS: No suppression

—
Table 96. Residual voltage measurement (RESVMMXU)

Characteristic	Value
Operation accuracy	Depending on the frequency of the measured current: $f/f_n = \pm 2$ Hz $\pm 0.5\%$ or $\pm 0.002 \times U_n$
Suppression of harmonics	DFT: -50 dB at $f = n \times f_n$, where $n = 2, 3, 4, 5, \dots$ RMS: No suppression

—
Table 97. Sequence voltage measurement (VSMSQI)

Characteristic	Value
Operation accuracy	Depending on the frequency of the voltage measured: $f_n \pm 2$ Hz At voltages in range $0.01 \dots 1.15 \times U_n$ $\pm 0.5\%$ or $\pm 0.002 \times U_n$
Suppression of harmonics	DFT: -50 dB at $f = n \times f_n$, where $n = 2, 3, 4, 5, \dots$

—
Table 98. Three-phase power and energy measurement (PEMMXU)

Characteristic	Value
Operation accuracy	At all three currents in range $0.10...1.20 \times I_n$ At all three voltages in range $0.50...1.15 \times U_n$ At the frequency $f_n \pm 1$ Hz $\pm 1.5\%$ for apparent power S $\pm 1.5\%$ for active power P and active energy1) $\pm 1.5\%$ for reactive power Q and reactive energy2) ± 0.015 for power factor
Suppression of harmonics	DFT: -50 dB at $f = n \times f_n$, where $n = 2, 3, 4, 5, \dots$

1) |PF| > 0.5 which equals |cosφ| > 0.5

2) |PF| < 0.86 which equals |sinφ| > 0.5

—
Table 99. RTD/mA measurement (XRGGIO130)

Description	Value		
RTD inputs	Supported RTD sensors	100 Ω platinum TCR 0.00385 (DIN 43760) 250 Ω platinum TCR 0.00385 100 Ω nickel TCR 0.00618 (DIN 43760) 120 Ω nickel TCR 0.00618 250 Ω nickel TCR 0.00618 10 Ω copper TCR 0.00427	
	Supported resistance range	0...2 kΩ	
	Maximum lead resistance (threewire measurement)	25 Ω per lead	
	Isolation	2 kV (inputs to protective ground)	
	Response time	<4 s	
	RTD/resistance sensing current	Maximum 0.33 mA rms	
	Operation accuracy	Resistance	± 2.0% or ±1 Ω
		Temperature	±1°C 10 Ω copper: ±2°C
	mA inputs	Supported current range	0...20 mA
		Current input impedance	44 Ω ± 0.1%
Operation accuracy		±0.5% or ±0.01 mA	

—
Table 100. Frequency measurement (FMMXU)

Characteristic	Value
Operation accuracy	±5 mHz (in measurement range 35...75 Hz)

Other functions

—
Table 101. Pulse timer (PTGAPC)

Characteristic	Value
Operate time accuracy	$\pm 1.0\%$ of the set value or ± 20 ms

—
Table 102. Time delay off (8 pcs) (TOFPAGC)

Characteristic	Value
Operate time accuracy	$\pm 1.0\%$ of the set value or ± 20 ms

—
Table 103. Time delay on (8 pcs) (TONGAPC)

Characteristic	Value
Operate time accuracy	$\pm 1.0\%$ of the set value or ± 20 ms

22. Local HMI

The relay is available with a large display. The large display is suited for relay installations where the front panel user interface is frequently used and a single line diagram is required.

The LCD display offers front-panel user interface functionality with menu navigation and menu views. The display also offers increased front-panel usability with less menu scrolling and improved information overview. In addition, the large display includes a user-configurable single line diagram (SLD) with position indication for the associated primary equipment. Depending on the chosen standard configuration, the relay displays the related measuring values, apart from the default single line diagram. The SLD view can also be accessed using the Web browser-based user

interface. The default SLD can be modified according to user requirements by using the Graphical Display Editor in PCM600. The user can create up to 10 SLD pages.

The local HMI includes a push button (L/R) for local/remote operation of the relay. When the relay is in the local mode, it can be operated only by using the local front panel user interface. When the relay is in the remote mode, it can execute commands sent from a remote location. The relay supports the remote selection of local/remote mode via a binary input. This feature facilitates, for example, the use of an external switch at the substation to ensure that all relays are in the local mode during maintenance work and that the circuit breakers cannot be operated remotely from the network control center.

Figure 12. Large display



Table 104. Large display

Character size ¹⁾	Rows in the view	Characters per row
Small, mono-spaced (6 × 12 pixels)	10	20
Large, variable width (13 × 14 pixels)	7	8 or more

¹⁾ Depending on the selected language

23. Mounting methods

By means of appropriate mounting accessories, the standard relay case can be flush mounted, semi-flush mounted or wall mounted. The flush mounted and wall mounted relay cases can also be mounted in a tilted position (25°) using special accessories.

Further, the relays can be mounted in any standard 19" instrument cabinet by means of 19" mounting panels available with cut-outs for one or two relays.

Mounting methods

- Flush mounting
- Semi-flush mounting
- Semi-flush mounting in a 25° tilt
- Rack mounting
- Wall mounting
- Mounting to a 19" equipment frame

Panel cut-out for flush mounting

- Height: 161.5 ±1 mm
- Width: 165.5 ±1 mm

Figure 14. Flush mounting

Figure 15. Semi-flush mounting

Figure 16. Semi-flush mounting in a 25° tilt

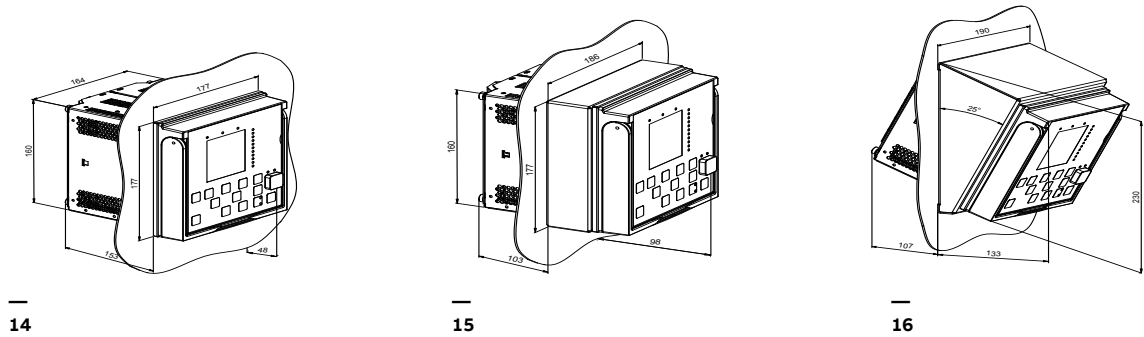

14

15

16

24. Relay case and plug-in unit

The relay cases are assigned to a certain type of plug-in unit. For safety reasons, the relay cases for current measuring relays are provided with automatically operating contacts for short-circuiting the CT secondary circuits when a relay unit is withdrawn from its case. The relay case is further provided with a mechanical coding system preventing the current measuring relay units from being inserted into relay cases intended for voltage measuring relay units.

25. Selection and ordering data

Use [ABB Library](#) to access the selection and ordering information and to generate the order number.

Product Selection Tool (PST), a Next-Generation Order Number Tool, supports order code creation for ABB Distribution Automation ANSI products with emphasis on but not exclusively for the Relion product family. PST is an easy to use, online tool always containing the latest product information. The complete order code can be created with detailed specification and the result can be printed and mailed. Registration is required.

26. Accessories and ordering data

Table 105. Mounting accessories

Item	Order number
Pilot Wire communication package including two Pilot Wire modems: RPW600AM (master) and RPW600AF (follower)	RPW600AMF
Diagnostics kit including the RPW-diagnostic tool, a diagnostic cable and a CD with necessary drivers and information	RPW600ADP
3.0 meter LC-LC single-mode fiber-optic patch cable for connecting one Pilot Wire modem to the RED615 relay ¹⁾	1MRS120547-3

1) Two patch cables are required for connecting the Pilot Wire communication package (RPW600AMF).

Table 106. Mounting accessories

Item	Order number
Semi-flush mounting kit	1MRS050696
Wall mounting kit	1MRS050697
Inclined semi-flush mounting kit	1MRS050831
19" rack mounting kit with cut-out for one relay	1MRS050694
19" rack mounting kit with cut-out for two relays	1MRS050695
Functional grounding flange for RTD modules ¹⁾	2RCA036978A0001

27. Tools

The protection relay is delivered as a preconfigured unit. The default parameter setting values can be changed from the front panel user interface (local HMI), the Web browser-based user interface (Web HMI) or Protection and Control IED Manager PCM600 in combination with the relay-specific connectivity package.

PCM600 offers extensive relay configuration functions. For example, depending on the protection relay, the relay signals, application, graphical display and single-line diagram, and IEC 61850 communication, including horizontal GOOSE communication, can be modified with PCM600.

When the Web HMI is used, the protection relay can be accessed either locally or remotely using a Web

browser (Internet Explorer). For security reasons, the Web HMI is disabled by default but it can be enabled via the local HMI. The Web HMI functionality can be limited to read-only access.

The relay connectivity package is a collection of software and specific relay information, which enables system products and tools to connect and interact with the protection relay. The connectivity packages reduce the risk of errors in system integration, minimizing device configuration and setup times. Further, the connectivity packages for protection relays of this product series include a flexible update tool for adding one additional local HMI language to the protection relay. The update tool is activated using PCM600, and it enables multiple updates of the additional HMI language, thus offering flexible means for possible future language updates.

Table 107. Tools

Characteristic	Value
PCM600	2.8
Web browser	IE 11.0
RED615 Connectivity Package	5.1 or later

Table 108. Supported functions

Function	Web HMI	PCM600
Relay parameter setting	•	•
Saving of relay parameter settings in the relay	•	•
Signal monitoring	•	•
Disturbance recorder handling	•	•
Alarm LED viewing	•	•
Access control management	•	•
Relay signal configuration (Signal Matrix)	-	•
Modbus® communication configuration (communication management)	-	•
DNP3 communication configuration (communication management)	-	•
Saving of relay parameter settings in the tool	-	•
Disturbance record analysis	-	•
XRIO parameter export/import	•	•
Graphical display configuration	-	•
Application configuration	-	•
IEC 61850 communication configuration, GOOSE (communication configuration)	-	•
Phasor diagram viewing	•	-
Event viewing	-	•
Saving of event data on the user's PC	•	•
Online monitoring	-	•

• = Supported

28. Cyber security

The relay supports role based user authentication and authorization. It can store 2048 audit trail events to a non-volatile memory. The non-volatile memory is based on a memory type which does not need battery backup or regular component exchange to maintain the memory storage. FTP and

Web HMI use TLS encryption with a minimum of 128 bit key length protecting the data in transit. In this case the used communication protocols are FTPS and HTTPS. All rear communication ports and optional protocol services can be deactivated according to the required system setup.

27. Terminal diagrams

Figure 17. Terminal diagram of standard configuration D

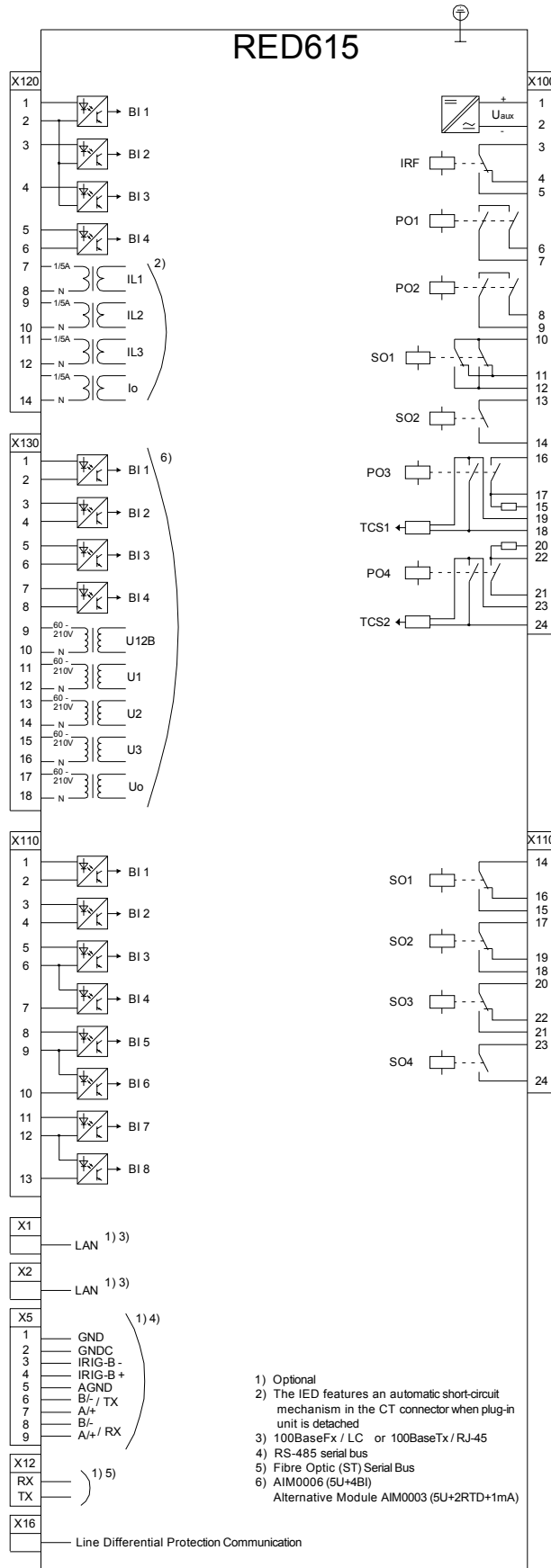
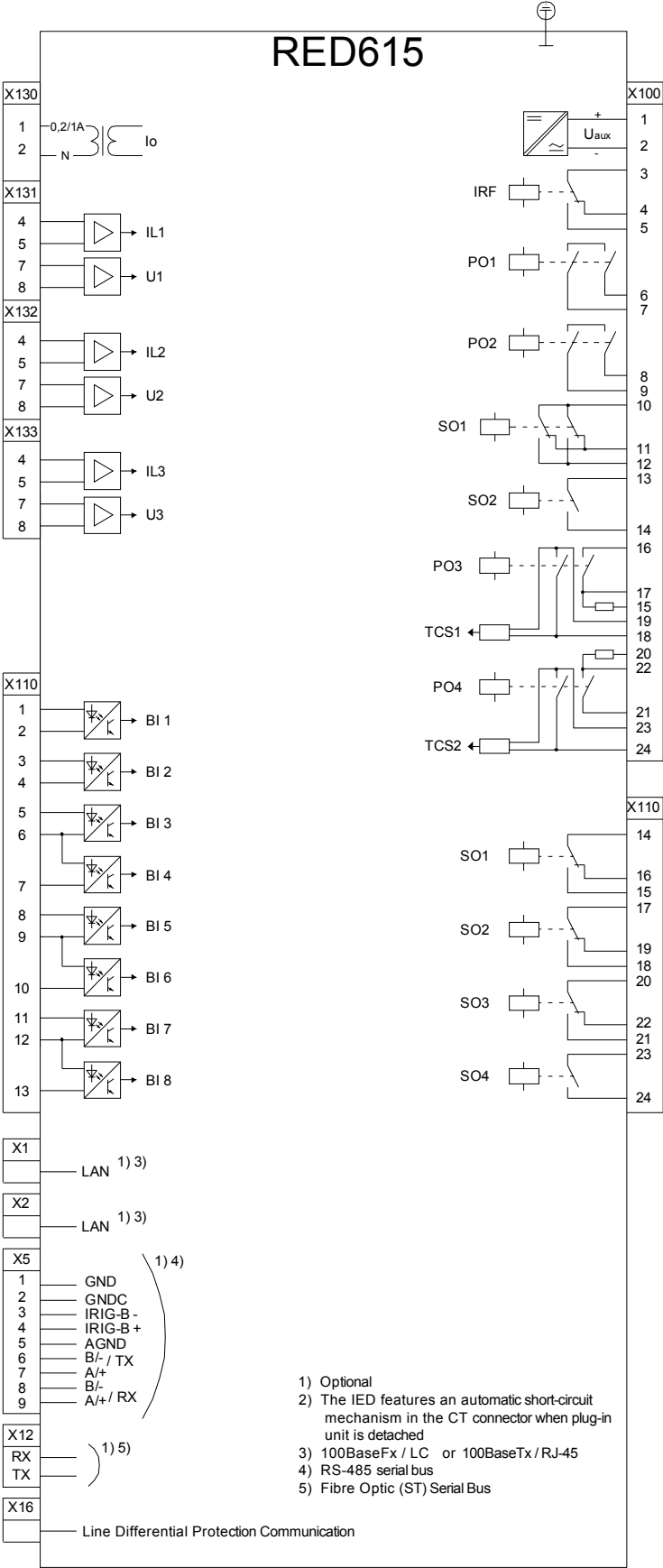

Figure 18. Terminal diagram of standard configuration E



28. Certificates

DNV GL has issued an IEC 61850 Edition 2 Certificate Level A1 for Relion® 615 series. Certificate number: 74105701-OPE/INC 15-1136.

DNV GL has issued an IEC 61850 Edition 1 Certificate Level A1 for Relion® 615 series. Certificate number: 74105701-OPE/INC 15-1145.

Additional certificates can be found on the **product page**.

29. References

The **www.abb.com/substationautomation** portal provides information on the entire range of distribution automation products and services. The latest relevant information on the RED615 protection and control relay is found on the product page. Scroll down the page to find and download the related documentation.

For information regarding the RPW600 modems please refer to the RPW600 User's Guide, document id 6621-2260. The document is available for download on the RED615 product page. Scroll down the page to find and download the related documentation.

30. Functions, codes and symbols

Table 109. Functions included in the relay

Function	IEC 61850	ANSI
Protection		
Three-phase non-directional overcurrent protection, instantaneous stage	PHLPTOC1	50P-3
Three-phase non-directional overcurrent protection, low stage	DPHLPDOC	67/51P
Three-phase non-directional overcurrent protection, high stage	DPHHPDOC	67/50P
Three-phase non-directional overcurrent protection, Non-directional ground-fault protection, high stage	PHIPTOC1	50P/51P (1)
Directional ground-fault protection, low stage	EFHPTOC	50G
Directional ground-fault protection, high stage	DEFHPDEF	67/51N
Admittance-based ground-fault protection	DEFHPDEF	67/50N
Wattmetric-based ground-fault protection	EFPADM	21YN
Transient/intermittent ground-fault protection	WPWDE	32N
Harmonics-based ground-fault protection	INTRPTEF	67NIEF
Negative-sequence overcurrent protection	HAEFPTOC	51NHA
Phase discontinuity protection	NSPTOC	46
Residual overvoltage protection	PDNSPTOC	46PD
Three-phase undervoltage protection	ROVPTOV	59G/59N
Three-phase overvoltage protection	PHPTUV	27
Positive-sequence undervoltage protection	PHPTOV	59
Negative-sequence overvoltage protection	PSPTUV	47U
Frequency protection	NSPTOV	47
Three-phase thermal protection for feeders, cables and distribution transformers	FRPFRQ	81
Three-phase thermal protection for feeders, cables and distribution transformers	T1PTTR	49F
Three-phase thermal protection for feeders, cables and distribution transformers	T2PTTR	49T
Binary Signal transfer	BSTGGIO	BST
Circuit breaker failure protection	CCBRBRF	50BF
Three-phase inrush detector	INRPHAR	INR
Switch onto fault	CBPSOF	SOTF
Master trip	TRPPTRC	86/94
Multipurpose protection	MAPGAPC	MAP
Fault locator	SCEFRFLO	21FL
Line differential protection with in-zone power transformer	LNPLDF	87L
High-impedance fault detection	PHIZ	HIZ
Power quality		
Current total demand distortion	CMHAI	PQI
Voltage total harmonic distortion	VMHAI	PQVPH
Voltage variation	PHQVVR	PQSS
Voltage unbalance	VSQVUB	PQVUB
Control		
Circuit breaker control	CBXCBR	52
Disconnecter control	DCXSWI	29DS
Grounding switch control	ESXSWI	29GS
Disconnecter position indication	DCSXSXI	52-TOC, 29DS
Grounding switch indication	ESSXSXI	29GS
Autoreclosing	DARREC	79
Synchronism and energizing check	SECRSYN	25
Conditioning monitoring and supervision		
Circuit breaker condition monitoring	SSCBR	52CM
Trip circuit supervision	TCSSCBR	TCM

Table 109. Functions included in the relay, continued

Function	IEC 61850	ANSI
Conditioning monitoring and supervision		
Current circuit supervision	CCSPVC	CCM
Fuse failure supervision	SEQSPVC	60
Protection communication supervision	PCSITPC	PCS
Runtime counter for machines and devices	MDSOPT	OPTM
Measurement		
Disturbance recorder	RDRE	DFR
Load profile record	LDPRLRC	LOADPROF
Fault record	FLTRFRC	FAULTREC
Three-phase current measurement	CMMXU	IA, IB, IC
Sequence current measurement	CSMSQI	I1, I2, IO
Residual current measurement	RESCMMXU	IG
Three-phase voltage measurement	VMMXU	VA, VB, VC
Residual voltage measurement	RESVMMXU	VG
Sequence voltage measurement	VSMSQI	V1, V2, V0
Single-phase power and energy measurement	SPEMMXU	SP, SE
Three-phase power and energy measurement	PEMMXU	P, E
RTD/mA measurement	XRGGIO130	X130 (RTD)
Frequency measurement	FMMXU	f
"IEC 61850-9-2 LE sampled value sending "	SMVSENDER	SMVSENDER
"IEC 61850-9-2 LE sampled value receiving (voltage sharing) "	SMVRCV	SMVRECEIVER
Other		
"Minimum pulse timer (2 pcs)"	TPGAPC	62TP
Minimum pulse timer (2 pcs, second resolution)	TPSGAPC	62TPS
Minimum pulse timer (2 pcs, minute resolution)	TPMGAPC	62TPM
Pulse timer (8 pcs)	PTGAPC	62PT
Time delay off (8 pcs)	TOFGAPC	62TOF
Time delay on (8 pcs)	TONGAPC	62TON
Set-reset (8 pcs)	SRGAPC	SR
Move (8 pcs)	MVGAPC	MV
"Generic control point (16 pcs)"	SPCGAPC	SPC
"Analog value scaling (4 pcs)"	SCA4GAPC	SCA4
"Integer value move (4 pcs)"	MVI4GAPC	MVI4
Generic up-down counters	UDFCNT	CTR

31. Document revision history

Document revision/date	Product version	History
A/2016-05-20	5.0 FP1	First release

Notes



—

ABB Inc.

4300 Coral Ridge Drive
Coral Springs, FL 33065
Phone: +1 954 752 6700

abb.com/mediumvoltage
abb.com/substationautomation