

# Stanilite®

## Platinum Spitfire® LED weatherproof Nexus® non-maintained



### Range

Platinum range

### Product group

Spitfire LED



### Features

- Superior photometric classification
- LED technology 100,000 hours plus lamp life
- Dual LED
- Low power consumption and LED light source for reduced operation and maintenance costs
- Polycarbonate IP67 weatherproof enclosure
- Advanced charging technology combined with Lithium iron phosphate battery for long life and low maintenance
- Nexus monitored, wireless
- RF frequency range 920 - 925 MHz
- Surface mount
- Low maintenance - ideal for car parks and coolrooms
- Ambient operating temperature; 10°C to 40°C

Catalogue no.	Description
<b>Nexus products</b>	
SGSFBWPNRF2LEDP	Platinum Spitfire dual LED weatherproof surface mount Nexus RF
<b>Spare parts</b>	
03-01310P	Battery LiFePO4 3.2V 3.2Ah

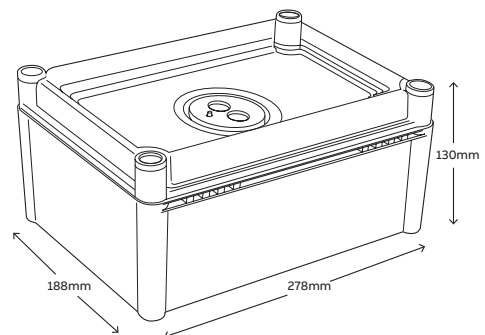

Dimensions		
Length	Width	Height
278mm	188mm	130mm
Weight		
Model	Weight	
Nexus RF	2.8kg	
Construction		
Part	Construction	
Lamp head	White polycarbonate	
Weatherproof enclosure	Polycarbonate	

<b>Light source</b>		
	<b>Model</b>	<b>Light source</b>
	Dual LED	3W

<b>Power consumption</b>		
	<b>Model</b>	<b>Power consumption</b>
	Nexus RF	1.0W

Note:

- Complies to IEC 60598-1:2014, IEC 60598-2-22:2014, IEC 60598-2-1:1979+A1:1987 and SS 563-2:2010