

K-DAR Field Test Unit

Effective: March 1977

Supersedes I.L. 41-493.1C, dated February 1975

Addendum #1 added

APPLICATION

This test unit is used to check (not to calibrate) the ohmic reach of the K-DAR family of relays and single-phase distance relays. All required test devices are self-contained and are designed to minimize test time. The unit requires only a single-phase 115-120 volt ac supply capable of carrying 25 amperes intermittently.

CONSTRUCTION

Fig. 1 shows the internal schematic of the unit. The unit consists of a current circuit, a voltage circuit, input and output cables, and auxiliary items (on-off switches, fuses, indicating lights, and a blocking diode). The overall dimensions of the test unit are approximately 19x11x9 inches and the weight of the unit is approximately sixty pounds. Fig. 3 shows the outline and switch locations.

Current Circuit

The current circuit consists of two 500-watt resistors, one air-gap reactor, a fault angle selector switch with taps P1 to P6, four range selector switches (high, medium, low and very low), three fault selector toggle switches, marked "off-AB", "off-BC", AND "off-CA/3 ϕ ", relay selector toggle switch, marked "KD, KD-1, KD-4(L), KD-41, KD-5, KD-4(S)," and fault type switch "3 ϕ -OFF- $\phi\phi$ ".

The resistors are mounted between front and rear panels. The reactor and current transformers are mounted on the rear panel.

Voltage Circuit

The voltage circuit consists of: one 200-watt resistor, an air-gap autotransformer, a variable autotransformer, a center-tapped inductor, and a rotary voltage selector switch.

Trip Indicator Circuit

The trip indicator circuit consists of: a 1/2watt resistor, a contact light, a diode which prevents false indications due to the arc suppression circuit in the phase-to-phase relay unit.

Cables

The input and output cables have plugs which engage sockets on the rear panel of the test unit.

Auxiliary Items

Other components of the test unit are: an "ON"- "OFF" master switch and associated pilot light, binding posts (ammeter, voltmeter) one 10-amp and two 30-amp fuses (mounted on the rear panel) which protect the voltage output and supply circuits respectively.

OPERATION

A basic schematic diagram of the test unit is shown in Fig. 2.

The test unit supplies the following electrical quantities to the K-DAR relays: a) balanced three-phase voltage triangle of variable magnitude, b) single-phase current of various fixed magnitudes and phase angle with respect to one of the delta voltages. c) voltage triangle that duplicates phase-to-phase fault condition.

Voltage Circuits

The three-phase voltage is obtained through a "phase splitter" which uses a resistor (tapped for various relays) in series with an airgap autotransformer to make the conversion from single phase. The three-phase test circuit uses a variable autotransformer

All possible contingencies which may arise during installation, operation or maintenance, and all details and variations of this equipment do not purport to be covered by these instructions. If further information is desired by purchaser regarding this particular installation, operation or maintenance of this equipment, the local ABB representative should be contacted.

K-DAR FIELD TEST UNIT

and the "phase-splitter." The phase-to-phase test circuit also uses these components in conjunction with a center-tapped inductor. The switching from "3 ϕ - Fault voltage triangle to " ϕ - ϕ " fault triangle is accomplished through operation of "3 ϕ - OFF - $\phi\phi$ " switch.

Current Circuits

A tapped resistor-reactor combination works in conjunction with a current transformer to give the

current magnitudes at the various phase angles. See CHARACTERISTICS for different angle magnitude settings available.

The available angle settings and available current ranges are listed below.

Single Phase Relay Testing

This unit may be used to test single-phase distance relays as described later.

TABLE I

P-SWITCH SETTING	CURRENT RANGE SWITCH SETTING			
	"HIGH"	"MEDIUM"	"LOW"	"VERY LOW"
P1	25.0 amp at 80°	10.1 amp at 86°	5.0 amp at 87°	2.0 amp at 87°
P2	23.6 amp at 70°	9.6 amp at 75°	4.8 amp at 75°	1.92 amp at 75°
P3	20.4 amp at 56°	8.3 amp at 60°	4.15 amp at 60°	1.6 amp at 60°
P4	16.5 amp at 43°	6.7 amp at 45°	3.35 amp at 45°	1.34 amp at 45°
P5	14.8 amp at 30°	6.0 amp at 30°	3.0 amp at 30°	1.20 amp at 30°
P6	24.3 amp at 3°	9.9 amp at 2°	4.8 amp at 1°	1.98 amp at 1°

CHARACTERISTICS

The test unit can check the relay reach at several angles as shown in Fig. 4.

The angles listed apply to $\phi\phi$ unit testing. For 3 ϕ unit test the angle value is increased by 30°.

Current values are measured at 120 volts ac input and are given here for reference only. The fault angle values should be within 2 degrees of the nominal value. The current value should be within 3 percent.

Accuracy

The accuracy of the check using the test unit consists of the accuracy of the calibration of the test unit itself, the relay accuracy, and the accuracy of the instruments used. The error varies from tap-to-tap, and from one type relay to another. In the worst case condition the error should not exceed 7 per cent. In most cases for higher ohmic relay setting, this error should not exceed 3 per cent at maximum torque angle or at angles very close to it. If the relay is checked at fault angle settings different from recommended, the error may be greater.

Repetitive checks will give highly consistent results provided the same unit is used. Therefore, it is possible to disregard errors of the test unit, if test unit readings are compared with those taken at previous check periods.

TEST PROCEDURE

CAUTION: The various ranges of current are obtained by using a current transformer. To avoid open-circuiting the secondary, these current range switches must never be turned "ON" unless a relay is connected to the unit and one of the current switches AB, BC, or CA is "ON". Also the resistors in the test unit are intermittently rated, therefore, the master switch should be "OFF" unless the tester is actually energizing the relay and determining the trip point.

NEVER change any switch position while master switch is "ON".

Step-by-Step Procedure for K-DAR Distance Type Relay Testing

1. Connect the output cable plug to the test unit

socket on the rear panel, and output test plugs to the relay being tested. The plugs are marked TOP and BOTTOM to indicate where they are to be plugged into the relay test switch assemblies.

2. Make sure master switch in in "OFF" position. (R. hand bottom-Front view.)
3. Connect the input cable to the receptacle on the rear panel and to a 115-120 volts, 60-cycle outlet with a 25 ampere capacity.
4. Determine type of relay being tested and set the relay select switch at the proper position. (R. hand - Above Master Switch.)
5. Calculate the reach setting at maximum torque angle from $Z_{\theta} = \frac{TS \sin \theta}{(1 + M) \sin \alpha}$ where α is nominal factory maximum torque angle setting as per Relay Instruction Leaflet. The angle θ - above is the actual maximum torque angle setting of the relay. On the basis of this reach setting, select High, Medium, Low, Very Low current range as per Table II. Select proper fault angle P-setting from Table III.
6. Determine type of fault to be tested (ϕ - ϕ or 3ϕ) and set current fault selector switch to the proper position. (R. Hand - Top Switch - Front View). Note: This switch has "OFF" position between the " ϕ - ϕ " and " 3ϕ " position.

If this is a 3ϕ fault, then the current toggle switch and the voltage rotary switch will be on CA/ 3ϕ . If not, then these switches will be on the ϕ - ϕ fault wanted, either AB, BC or CA.

7. When testing KD-1 or KD-41 type relays, block contacts open on relay unit not being used, and REMOVE the lead from terminal 11 on the upper test plug.

Note that for a given P-switch setting the angle of current lag is different for the phase-to-phase and three-phase units. For example, when checking a KD relay on the Medium Range at 75° , use P2 settings, but use P4 setting when checking the 3-phase unit.

Multiplying Factor Method:

1. Make sure ammeter link is in place.
2. Turn master switch on and adjust variable auto-transformer until the relay just trips. Turn master switch off. Record variable auto-transformer reading (V.R.) angle and range position.
3. Determine multiplying factor (M.F.) from table IV.
4. Calculate reach by means of the formula:

Phase-to-Phase Reach (Relay ohms) =
V.R. x (MF) $\phi\phi$

3-Phase-to-Phase Reach (Relay ohms) =
V.R. x (MF) 3ϕ
5. Compare test results with nominal reach, Z_d , where $Z_d = Z_{\theta} \cos d$. Where d is defined as per Fig. 4, as the difference between the maximum torque angle of the relay and the test box angle P (Table III).

**TABLE II
RECOMMENDED CURRENT RANGES**

RELAY SETTING (OHMS)	RANGE	
	$\phi - \phi$ UNIT	3 ϕ UNIT
KD-4 AND KD-5 (.2-4.35 OHMS)		
.2 - .84	High	High
.85 - 2.90	Medium	Medium
2.91 - 4.35	Medium	Low
KD, KD-4 AND KD-1, KD-41 (.75 - 21 OHMS)		
.73 - 1.07	High	High
1.08 - 2.44	Medium	High
2.45 - 6.60	Medium	Medium
6.61 - 9.9	Low	Low
9.91 - 14.12	Low	Low
14.31 - 21.1	Very Low	Very Low
KD-4, KD-41 (1.1 - 30 OHMS)		
1.1 - 1.32	High	High
1.33 - 2.44	Medium	High
2.45 - 4.60	Medium	Medium
4.61 - 7.05	Low	Medium
7.06 - 7.50	Low	Low
7.51 - 14.12	Very Low	Low
14.12 - 31.0	Very Low	Very Low

TABLE III
FAULT ANGLE SETTINGS

P-SWITCH SETTING	ANGLE SETTINGS FOR GIVEN CURRENT RANGE			
	ϕ - ϕ UNIT		3 ϕ UNIT Δ	
	"HIGH"	"MEDIUM", "LOW", "VERY LOW"	"HIGH"	"MEDIUM", "LOW", "VERY LOW"
P1	80°	86°	110°	116°
P2	70°	75°	100°	105°
P3	56°	60°	86°	90°
P4	43°	45°	73°	75°
P5	30°	30°	60°	60°
P6	3°	1°	33°	31°

Select P-setting closest to the maximum torque angle setting of the relay, then select next higher and next lower P-setting. Note that for KD-5 3 ϕ -unit with nominal maximum torque angle of 35° it is impossible to have the angle lower than 33°-32°, hence use P5 and P4 settings only.

Δ This angle includes 30° correction for 3 ϕ -unit phase relationship.

Instrument Method: (alternative)

1. Connect ammeter to ammeter binding posts and voltmeter to terminals A and B on the test unit when testing phase-to-phase unit and connect voltmeter to terminals B and C when testing the 3-phase unit.
2. Turn Master Switch ON and adjust the variable auto-transformer until the relay just trips. Record current and V_{AB} for phase-to-phase unit

and V_{BC} - for 3-phase unit. Turn Master Switch OFF.

3. Calculate reach from formulas:

$$\text{Reach (relay ohms)} = \frac{V_{AB}}{I_L} \text{ (Phase-to-phase)}$$

or -

$$\text{Reach (relay ohms)} = \frac{V_{BC}}{\sqrt{3} I_L} \text{ (Three-phase)}$$

Note that for 3 phase test V_{BC} voltage should be measured.

4. Compare test results with nominal reach Z_d , where $Z_d = Z_{\theta} \cos d$, where d -angle difference between the maximum torque angle of the relay and the test box angle P (Table III).

**TABLE IV
MULTIPLYING FACTORS**

ANGLE SETTING	CURRENT RANGE			
	HIGH	MEDIUM	LOW	VERY LOW
A. PHASE-TO-PHASE UNIT - (M.F.) $\phi\phi$				
P1	.020	.051	.100	.250
P2	.021	.053	.104	.275
P3	.0245	.0615	.123	.315
P4	.0325	.075	.155	.413
P5	.046	.108	-	-
B. THREE PHASE - (M.F.) 3ϕ				
P2	.0230	.062	.122	.310
P3	.0290	.072	.140	-
P4	.037	.091	.182	.460
P5	.040	.102	.193	-
P6	.024	.061	.118	.288

KD Relay Test Example:

Assume T = 5.8, M = + 0.12, S = 2, Maximum torque angle $\theta = 60^\circ$

then

$$Z_{\theta} = \frac{TS \sin \theta}{(1 + M) \sin 75^\circ} = \frac{5.8 \times 2 \sin 60^\circ}{(1 + 0.12) \sin 75^\circ}$$

$$= 10.4 \frac{\sin 60^\circ}{\sin 75^\circ} = 10.4 \times 0.90 = 9.35 \text{ ohms}$$

From Table II and III use the settings for the $\phi\phi$ and 3ϕ units as tabulated below.

CURRENT RANGE SETTINGS FROM TABLE II		FAULT ANGLE FROM TABLE II	ANGLE d	NOMINAL REACH AT P.F. ANGLE $Z_d = Z\theta \cos d$	M.F. FROM TABLE IV
"Low"	Phase-to-Phase Unit	P2 (75°)	15°	9.03	.104
		P3 (60°)	0°	9.35	.123
		P4 (45°)	15°	9.03	.155
"Low"	3 Phase Unit	P4 (75°)	15°	9.03	.182
		P5 (60°)	0°	9.35	.193
		P6 (32°)	28°	8.35	.118

Proceed as follows for $\phi\phi$ unit check:

A) AB fault (75° check)

1. Master Switch - Off Position
2. $\phi\phi$ - 3 ϕ Switch in $\phi\phi$ position.
3. Auto Transformer dial set for maximum voltage setting.
4. Insert plugs in relay and test unit and connect to power supply.
5. KD-5, KD-4 (S) - KD, etc. switch in KD-position.
6. From Table III, set P2 for 75° test. Turn "LOW" current switch on.
7. Place current toggle switch in "AB" position; turn voltage switch to "AB" position.
8. Turn Master Switch on, adjust variable auto-transformer until relay just trips, as indicated by small red light.

Assume that dial reads 87.

Indicated reach = V.R. x (MF) $\phi\phi$ = 87 x .104 = 9.05 ohms

Compare to nominal reach of 9.03 ohms.

B) BC Fault (75° Check)

Repeat step 8 with "BC" current switch on and voltage switch in "BC" position.

C) CA Fault (75° Check)

Repeat step 8 with "CA" current switch on and voltage switch in "CA" position.

D) AB Fault (60°)

Return to step 6, by setting fault angle switch to P₃. Repeat steps 7 and 8. Compare to nominal reach of 9.35 ohms.

E) BC Fault (60°)

Repeat step 8 with "BC" current switch on and voltage switch in "BC" position.

F) CA Fault (60°)

Repeat step 8 with "CA" current switch on and voltage switch in "CA" position.

G) AB Fault (45°)

Return to step 6, by setting fault angle switch to P₄. Repeat steps 7 and 8. Compare to nominal reach of 9.03 ohms.

H) BC Fault (45°)

Repeat step 8 with "BC" current switch on and voltage switch in "BC" position.

I) CA Fault (45°)

Repeat step 8 with "CA" current switch on and voltage switch in "CA" position.

K-DAR FIELD TEST UNIT

Now returning to step 6, proceed as follows for 3 ϕ -unit check:

6. From Table III, set fault angle switch to P4 and turn "low" current switch on.
7. Place current toggle switch in CA-3 ϕ position. Turn voltage switch to CA/3 ϕ position.
8. Assume dial reading is 50 of then-indicated reach.

$$50 \times .182 = 9.10$$

Compare to nominal reach of 9.03 ohms
Repeat step (8) for 60° check with unit set in P₅.
Repeat step (8) for 32° check with unit set in P₆.

Step-by-Step Procedure for KS Testing

1. Make sure master switch is in Off position.
2. $\phi\phi/3\phi$ switch in $\phi\phi$ position.
3. Set variac dial for maximum setting.
4. Connect the input cable to receptacle on rear panel and to 115 volt, 60 cycle outlet with 25 ampere capacity. Connect the output cable plug to test unit socket on rear panel, and output test plugs to the relay being tested.
5. Note that no contact light circuit is possible.
6. Calculate the forward reach setting at maximum torque angle from
$$Z_L = \frac{TS}{1 \pm M} \frac{\sin \theta}{\sin 75^\circ}$$
Check this value as outlined below
7. Choose current range from Table 1 as listed under phase-to-phase unit.
8. Turn on "CA" current toggle switch.
9. Turn voltage switch to "CA" position.
10. a. Connect ammeter to ammeter binding posts and voltmeter to terminals A and B on the test unit.
b. Turn Master Switch "ON" and adjust the variable auto-transformer until the relay just trips. Record current and V_{AB}. Turn Master Switch "OFF".

- c. Calculate reach from formulas:

$$\text{KS Forward Reach (relay ohms)} = \frac{V_{AB} (\text{phase-to-phase})}{I_L}$$

- d. Compare test results with nominal reach, Z_d, where:

$$Z_d = Z_\theta \cos d$$

Where d is the angle between the KS maximum torque angle and the test box angle setting as shown in Table 1.

11. Return to step 8. Set current toggle switch to "AB" position.
12. Set voltage switch to "AB" position.
13. Proceed as per step 10 above

KS Phase B Compensator Check

The above forward reach tests check calibration of phase A and C compensator and phase B voltage circuit continuity. A calibration check of the phase B compensator, if desired, can be best done by measuring the induced secondary voltage with a high resistance voltmeter (5000 ohm/volt) by the following procedure:

1. Turn $\phi\phi$ -3 ϕ switch to ϕ - ϕ position.
2. Connect ammeter to ammeter binding posts.
3. Set in current switch to tap P₆ -
4. Turn on "BC" current toggle switch, and "Medium".
5. Temporarily disconnect the "L" leads of M_A and M_C of the KS relay.
6. Connect high resistance voltmeter to terminal 8 and the fixed end of R_{2B}.
7. Turn Master Switch on and read ammeter and voltmeter.
8. The voltage reading, V_C, should be:

$$V_C = (T_B + T_B') I \frac{\sin \theta}{\sin 75^\circ}$$

where, I = ammeter reading

$$T_B + T_B' = \text{KS compensator settings.}$$

$$\theta = \text{Maximum torque angle or relay.}$$

Procedure for Single-Phase Distance Relay Testing

The test unit may be used to test any single-phase distance relay, for instance, the HZ or HZM.

Since the burden of the relay circuits varies considerably, it is necessary to use an ammeter and voltmeter when testing the relay. If the total series impedance of the current circuit is less than .75 ohm, it is not necessary to use a phase angle meter. The angles listed in Table I for phase-to-phase testing will hold to within 2° or 3° for single phase testing.

The instruction leaflet for the relay being tested should be consulted. Balance point checks for a particular voltage, such as 10V, or 30 V, are not possible with the test unit since only 4 fixed values of current (corresponding to Low, Medium, and High impedance range) are available at any given angle. However, by using I.L. curves of impedance vs. phase angle and impedance vs. voltage, it is possible to interpolate between test unit results and thereby check the relay calibration.

Follow this Procedure When Testing Single-Phase Distance Relays:

1. Make sure Master Switch is in Off position, except when actually determining relay balance point.
2. Disconnect output cable from test unit. Throw relay selector switch to any position. Throw AB, BC, and CA current switches to ON. Remove link from terminals marked "Ammeter" on lower left side of test unit front panel. Connect relay current circuit and ammeter between these terminals, with the left side terminal being polarity. This completes the current circuit through the test unit, ammeter, and relay. It may be desirable to insert a toggle switch in the relay current circuit to facilitate timing tests.
3. Throw $3\phi-\phi\phi$ switch to 3ϕ - position. Connect relay potential circuit and the voltmeter across test unit voltmeter terminals A and B, with terminal A being polarity.
4. Select High, Medium, Low range, or Very Low. These ranges provide approximately maximum 2.0, 5.0, 10, and 25 amperes, respectively. Select test unit tap, based on desired phase angle of current lag voltage. (See Table 1 under Phase-to-Phase.)
5. Turn Master Switch on and adjust variable auto-transformer until balance point is obtained. Read values of current and voltage at balance point.
6. Turn Master Switch OFF.

TEST TABLE

DISTANCE RELAY TEST USING K-DAR TEST SET, SET ID # XYZ

TYPE KD-4 STYLE NUMBER 292B885A15 ID# ABC1234 RANGE 0.75 - 20

TESTER JOHN DOE DATE 1 / 17 / 73 APPLICATION ZONE 1 - FAIRVIEW LINE 1 2 3

$\phi\phi$ UNIT Z = 5.04 T = 5.8 S = 1 M = + .15 R = .06 I = .03 R/L or L/R MAX TORQUE 75°

3ϕ UNIT Z = 5.05 T = 5.8 S = 1 M = + .15 R = .06 I = .03 R/L or L/R MAX TORQUE 75°

CURRENT: HIGH LOW VERY LOW (see pg. 4)

P SETTING (see pg. 4)	NOMINAL ANGLE (see pg. 5)	d *	COS d	Z COS d	MUL FACTOR (see pg. 6)	DIAL THEORETICAL **	DIAL - TEST READINGS		
							AB	BC	CA
P 1	86	11	.980	4.93	.051	97			
P 2	75	0	1.000	5.04	.053	95			
P 3	60	15	.965	4.85	.0615	79			

* = Max Torque
 ** Dial Theoretical = $\frac{Z \cos d}{\text{Mul. Factor}}$

CURRENT: HIGH LOW VERY LOW (see pg. 4)

P SETTING (see pg. 5)	NOMINAL ANGLE (see pg. 5)	COS d	Z COS d	MUL FACTOR (see pg. 6)	DIAL THEORETICAL **	DIAL TEST
P 4	75	1.000	5.04	.091	55.3	
P 5	60	.965	4.85	.102	47.5	

SUBSEQUENT FIELD CHECKS

DATE	DIAL READINGS			DATE	DIAL READINGS			DATE	DIAL READINGS		
	$\phi\phi$	3ϕ	3ϕ DIAL READING		$\phi\phi$	3ϕ	3ϕ DIAL READING		$\phi\phi$	3ϕ	3ϕ DIAL READING
	P				P				P		
	$\phi\phi$				$\phi\phi$				$\phi\phi$		
	P				P				P		
	3ϕ				3ϕ				3ϕ		
	P				P				P		
	3ϕ DIAL READING				3ϕ DIAL READING				3ϕ DIAL READING		

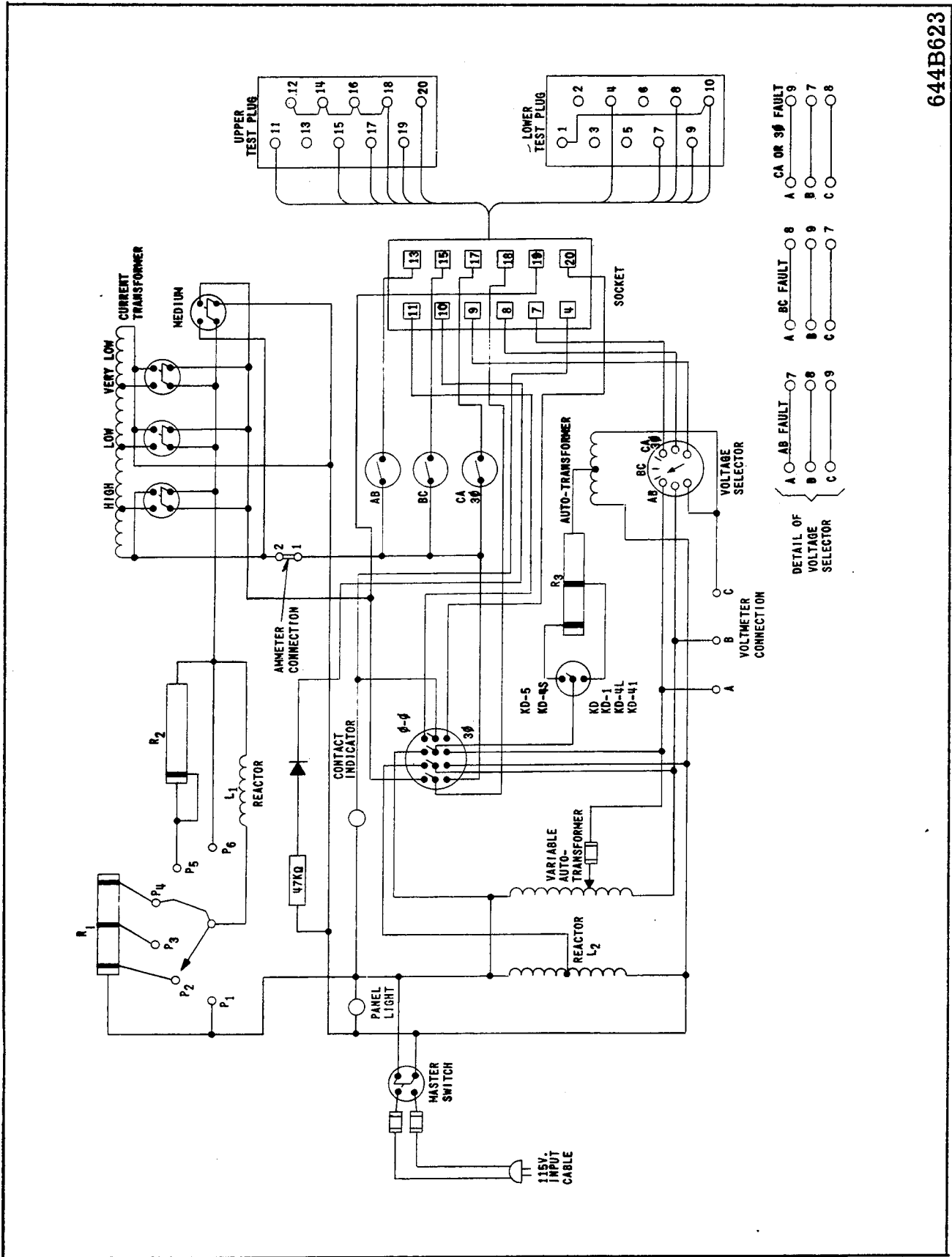

644B623

Fig. 1 Internal Schematic

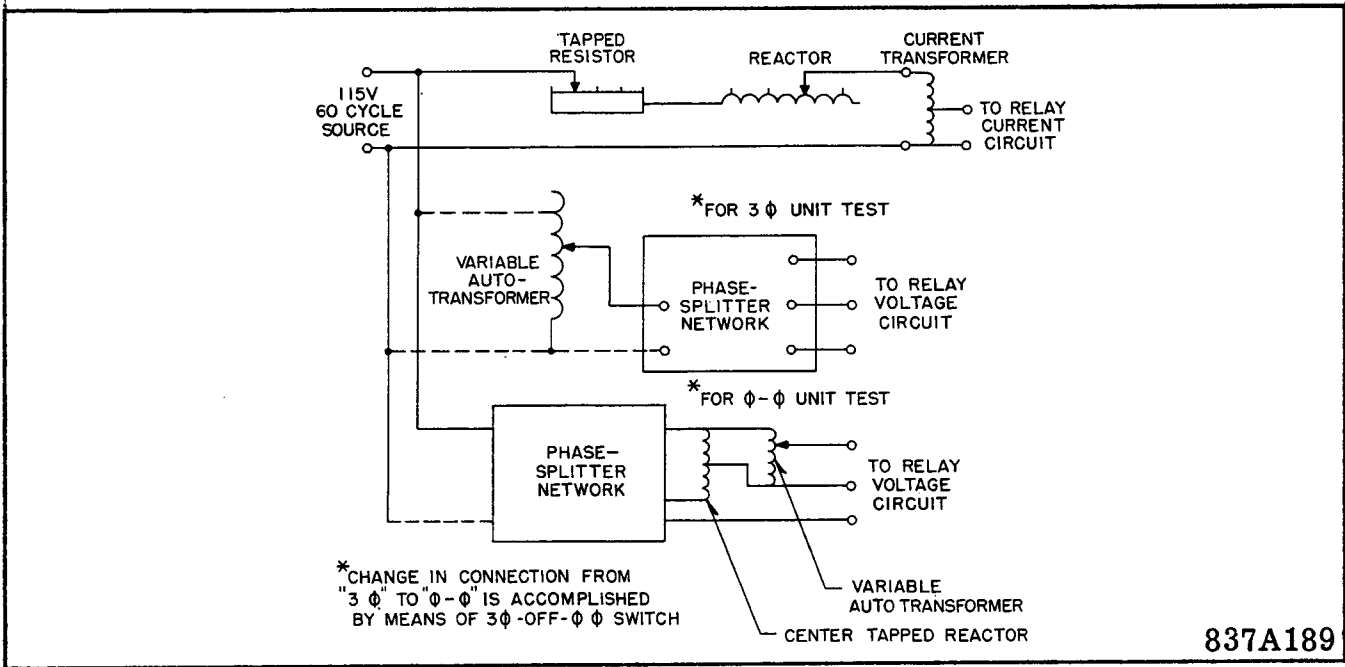

Fig. 2 Basic Schematic Diagram

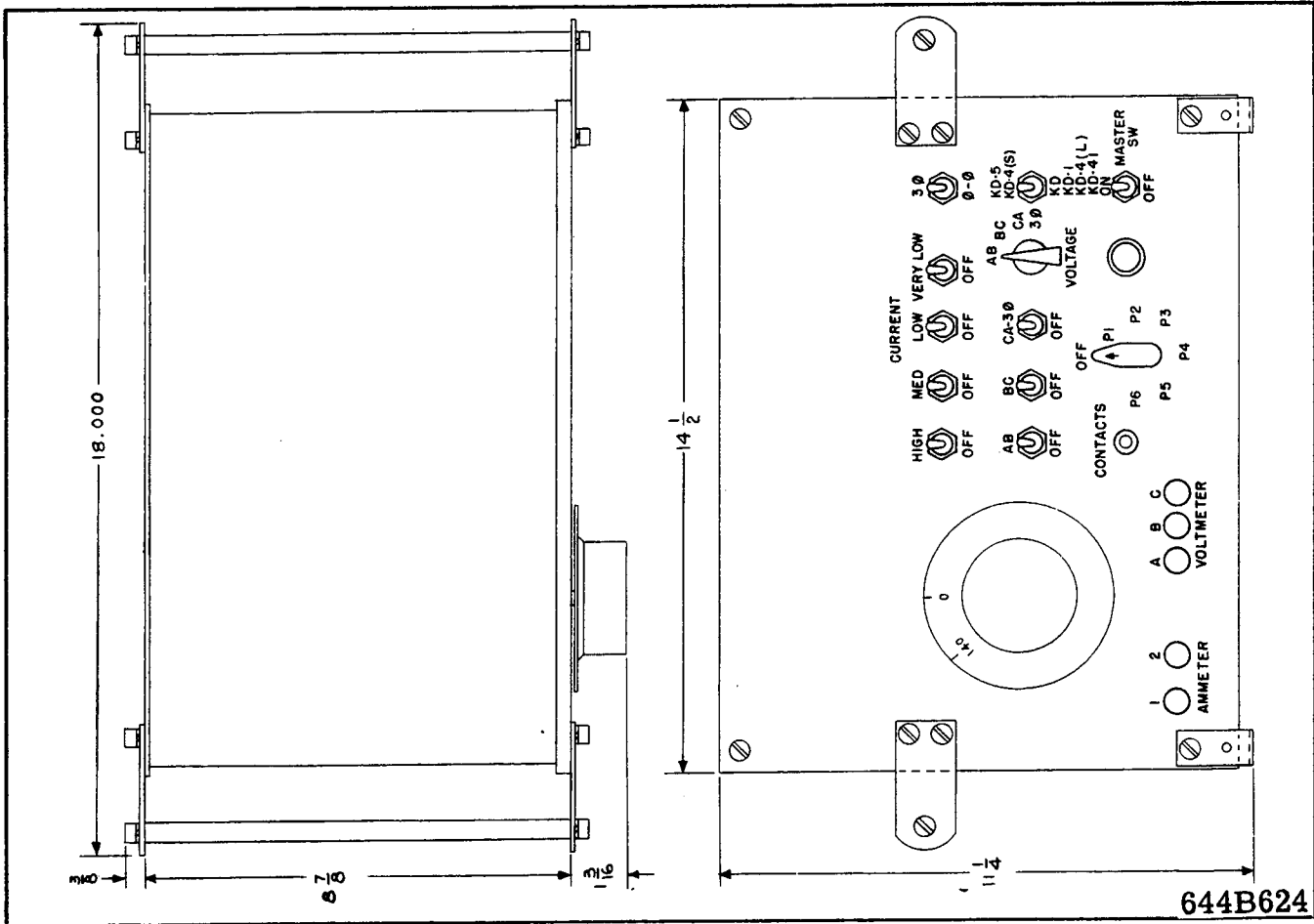

Fig. 3 Outline Drawing

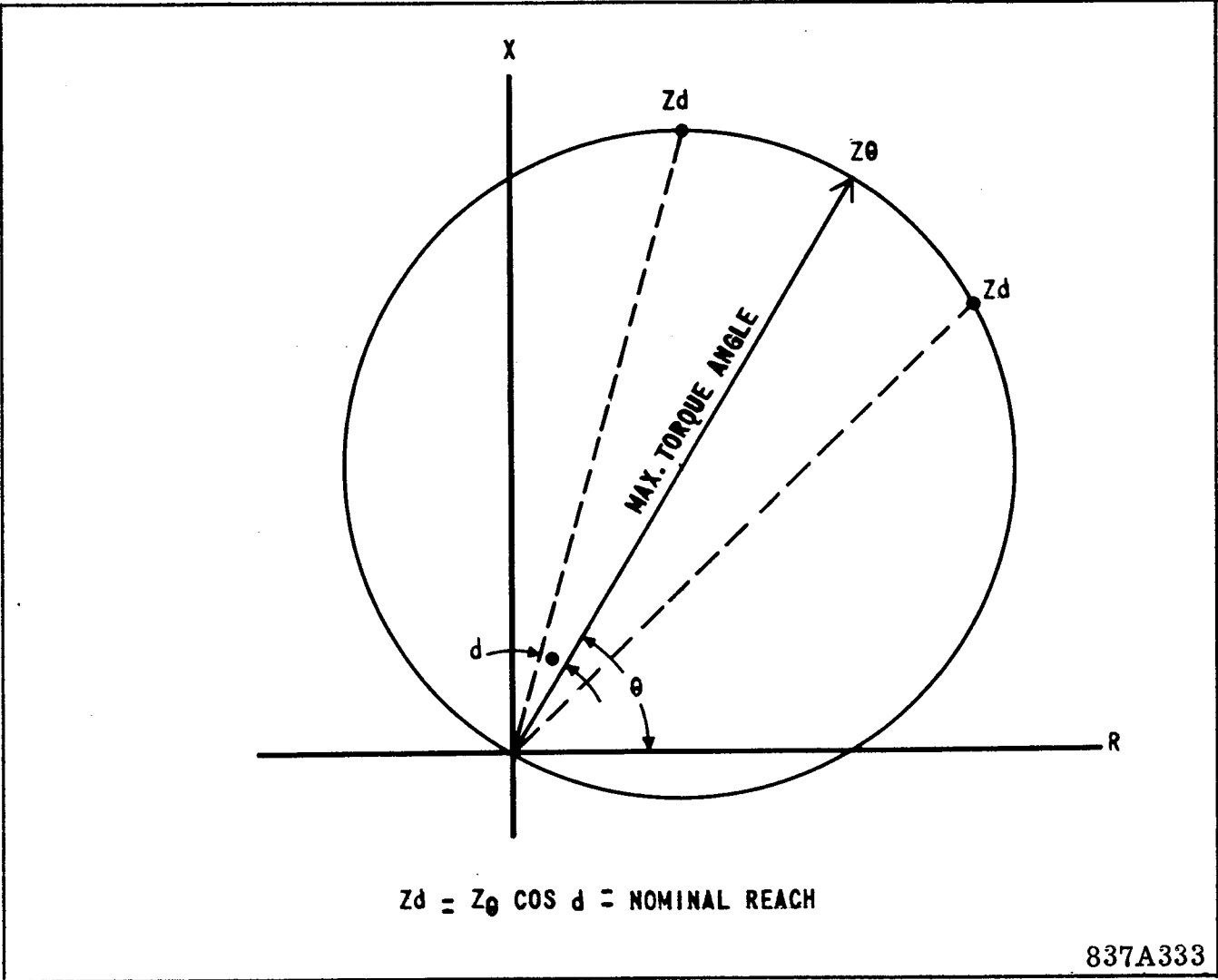

Fig. 4 Test Unit Check Points

ADDENDUM NO.1 FOR KD-10 AND KD-11 RELAY TESTING

TEST PROCEDURE

CAUTION: The various ranges of current are obtained by using a current transformer. To avoid open-circuiting the secondary, these current range switches must never be turned "ON" unless a relay is connected to the unit and one of the current switches AB, BC, or CA is "ON". Also the resistors in the test unit are intermittently rated, therefore, the master switch should be "OFF" unless the tester is actually energizing the relay and determined the trip point.

NEVER change any switch position while master switch is "ON".

Step-by-Step Procedure for K-DAR Distance Type Relay Testing

1. Connect the output cable plug to the test unit socket on the rear panel, and output test plugs to the relay being tested. The plugs are marked TOP and BOTTOM to indicate where they are to be plugged into the relay test switch assemblies.
2. Make sure master switch is in "OFF" position. (R. hand bottom-Front view.)
3. Connect the input cable to the receptacle on the rear panel and to a 115-120 volts, 60 hertz outlet with 15 ampere capacity.
4. Set the relay select switch (R. hand-above "Master Switch") into "KD-4" position when testing KD-10 and for "KD-41" position when testing KD-11 relay.
5. Establish relay reach and maximum torque angle from tap plate settings and name plate information. Note that if relay is recalibrated for a maximum torque angle a , different from the standard factory setting, its reach is $Z_{\theta} = \frac{TS \sin \theta}{(1 + M) \sin a}$ where a is nominal factory maximum torque angle setting as per Relay Instruction Leaflet. The angle θ - above is the actual maximum torque angle setting of the relay.
6. Select High, Medium, Low, Very Low current range as per Table II. Select proper fault angle P-setting from Table III.

Note that for a given P-switch setting the angle of cur-

rent lag is different for the phase-to-phase and three-phase units. For example, when checking a KD relay on the Medium Range at 75°, use P2 settings, but use P4 setting when checking the 3-phase unit.

7. Determine type of fault to be tested (ϕ - ϕ or 3ϕ) and set current fault selector switch to the proper position. (R. Hand - Top Switch - Front View).
Note: This switch has "OFF" position between the " ϕ - ϕ " and " 3ϕ " position.

If this is a 3ϕ fault, then the current toggle switch and the voltage rotary switch will be on CA/ 3ϕ . If not, then these switches will be on the ϕ - ϕ fault wanted, either AB, BC or CA.

When testing KD-10 or KD-11 type relays, block contacts open on relay unit not being used, and REMOVE the lead from terminal 11 on the upper test plug.

Further note that a few special relays have different contact arrangement than standard relays, in this case observe contact operation on the relay.

Multiplying Factor Method:

1. Make sure ammeter link is in place.
2. Turn master switch on and adjust variable auto-transformer until the relay just trips. Turn master switch off. Record variable auto-transformer reading (V.R.) angle and range position.
3. Determine multiplying factor (M.F.) from Table V.
4. Calculate reach by means of the formula:

$$\text{Phase-to-Phase Reach (Relay ohms)} = \text{V.R.} \times (\text{MF}) \phi\phi$$

$$\text{3-Phase-to-Phase Reach (Relay ohms)} = \text{V.R.} \times (\text{MF}) 3\phi$$

5. Compare test results with nominal reach, Z_d , where $Z_d = Z_{\theta} \cos d$. Where d is defined as per Fig. 4, as the difference between the maximum torque angle of the relay and the test box angle P (Table III).

KD-10 & 11
0.2-4.5 Ω

**TABLE IV
MULTIPLYING FACTORS**

ANGLE SETTING	CURRENT RANGE							
	HIGH		MEDIUM		LOW		VERY LOW	
	S = 1	S = 2 S = 3	S = 1	S = 2 S = 3	S = 1	S = 2 S = 3	S = 1	S = 2 S = 3
A. PHASE-TO-PHASE UNIT - (M.F.) φφ								
P1	.208	.020	.051	.051	-	-	-	-
P2	.021	.021	.053	.053	-	-	-	-
P3	.0265	.0245	.0615	.060	-	-	-	-
P4								
P5								
B. THREE PHASE - (M.F.) 3φ								
P2								
P3	-	-	-	-	-	-	-	-
P4	.036	.033	-	.088	-	.171	-	-
P5	.040	.036	-	.097	-	.187	-	-
P6	.025	.023	-	.058	-	.113	-	-

KD-10 & 11
0.75-21.0 Ω

**TABLE IV
MULTIPLYING FACTORS**

ANGLE SETTING	CURRENT RANGE							
	HIGH		MEDIUM		LOW		VERY LOW	
	S = 1	S = 2 S = 3	S = 1	S = 2 S = 3	S = 1	S = 2 S = 3	S = 1	S = 2 S = 3
A. PHASE-TO-PHASE UNIT - (M.F.) φφ								
P1	.019	-	.050	.051	.100	.100	-	.250
P2	.020	-	.052	.053	.104	.106	-	.260
P3	.024	-	.060	.061	.121	.119	-	.300
P4								
P5								
B. THREE PHASE - (M.F.) 3φ								
P2	-	-	-	-	-	-	-	.300
P3	.028	.027	.069	.069	.140	.138	-	Use P2
P4	.036	.035	.090	.088	.182	.179	-	.440
P5	.040	.038	.102	.097	.199	.193	-	Use P6
P6	-	-	-	-	-	-	-	.310

KD-10 & 11
1.3-36.0 Ω

**TABLE IV
MULTIPLYING FACTORS**

ANGLE SETTING	CURRENT RANGE							
	HIGH		MEDIUM		LOW		VERY LOW	
	S = 1	S = 2 S = 3	S = 1	S = 2 S = 3	S = 1	S = 2 S = 3	S = 1	S = 2 S = 3
A. PHASE-TO-PHASE UNIT - (M.F.) φφ								
P1	.019	-	.049	-	.098	-	.250	.250
P2	.020	-	.053	-	.103	-	.264	.275
P3	.0245	-	.0615	-	.121	-	.303	.294
P4								
P5								
B. THREE PHASE - (M.F.) 3φ								
P2	-	-	-	-	-	-	-	.310
P3	.026	-	-	.072	-	.140	-	-
P4	.036	-	-	.093	-	.182	-	.440
P5	.040	-	-	.102	-	.193	-	-
P6	-	-	-	-	-	-	-	.288

THIS PAGE RESERVED FOR NOTES

THIS PAGE RESERVED FOR NOTES



ABB Inc.

4300 Coral Ridge Drive
Coral Springs, Florida 33065

Telephone: +1 954-752-6700

Fax: +1 954-345-5329

www.abb.com/substation_automation

IL 41-493.1 - Revision D