

Industrial^{IT} for Energy Management

From the turbine, generator, transformer and circuitbreaker including the related protection, all the way up to the control and load management, ABB offers a full spectrum of products and system solutions to improve the stability and optimize the operation of electrical networks.

A wide range of standard products and solutions are available for a cost-efficient and reliable load management.

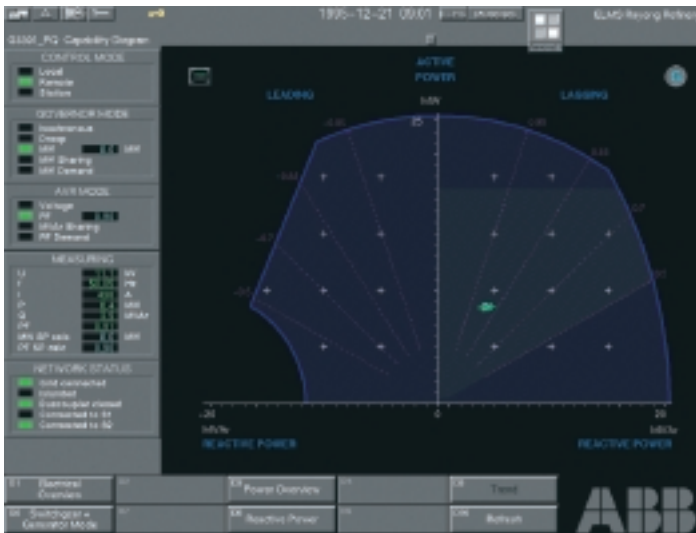

- Intelligent Alarm Filtering.
- Consistency Analysis.
- Disturbance Data Analysis.

Industrial^{IT} for Energy Management helps you to:

Avoid Black-outs

In case of a lack of power, Load Shedding secures the electrical power to critical loads by switching off non-critical loads according to dynamic priority tables.

Peak Shaving/Electricity cost saving

When all the in-house generation is maximized and the power demand still tends to violate the contracted maximum value, the system will start to shed some of the low priority loads.

Capabilities of Industrial^{IT} for Energy Management

- Fast Load Shedding at loss of power supply sources.
- Slow Load Shedding in case of overload (Peak Shaving).
- Active and Reactive Power Control.
- Power Sharing.
- Synchronization.
- Re-acceleration and re-starting.
- Mode Control.
- Generator and Turbine Control with integration of Excitation and Governor Controller.
- Transformer and Tapchanger Control.
- Circuitbreaker Control with integration of protection relays.
- Motor Control with integration of Motor Control Centers.
- SCADA functionality including:
 - Time Tagged Events (1 ms accuracy).

Minimal Operator Requirements

Several generators generate the electrical energy, which normally implies extra control activities for the operators. Additional functions such as intelligent alarm filtering, consistency analysis, operator guidance and single window concept minimize your operator requirements.

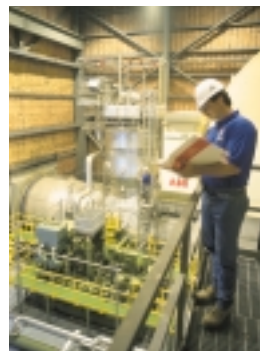

Achieve stable operation

The Power Control function shares the active and reactive power between the different generators and ties lines in such a way that the working points of the machines are as far as possible away from the border of the individual PQ-capability diagrams so that the plant can withstand bigger disturbances.

Optimized Network Design

Because the setpoints for the generators, turbines and transformers are calculated in such a way that no component will be overloaded and the electrical network can be used up to its limits, over-dimensioning of the network is no longer needed.

Minimize Cabling and Engineering

All the signals and information which are available in protection/control relays, governor/excitation con-

trollers and other microprocessor based equipment can be easily transmitted to Industrial IT for Energy Management via serial communication links. This avoids marshalling cubicles, interposing relays, cable ducts, spaghetti wiring, cabling engineering and provides extra functionality such as parameter setting/reading, stored events, disturbance data analysis and a single window to all electrical related data.

Integrated System Solutions

ABB provides a common automation architecture for integrated system solutions that include safety, instrumentation, electrical and analytic systems.

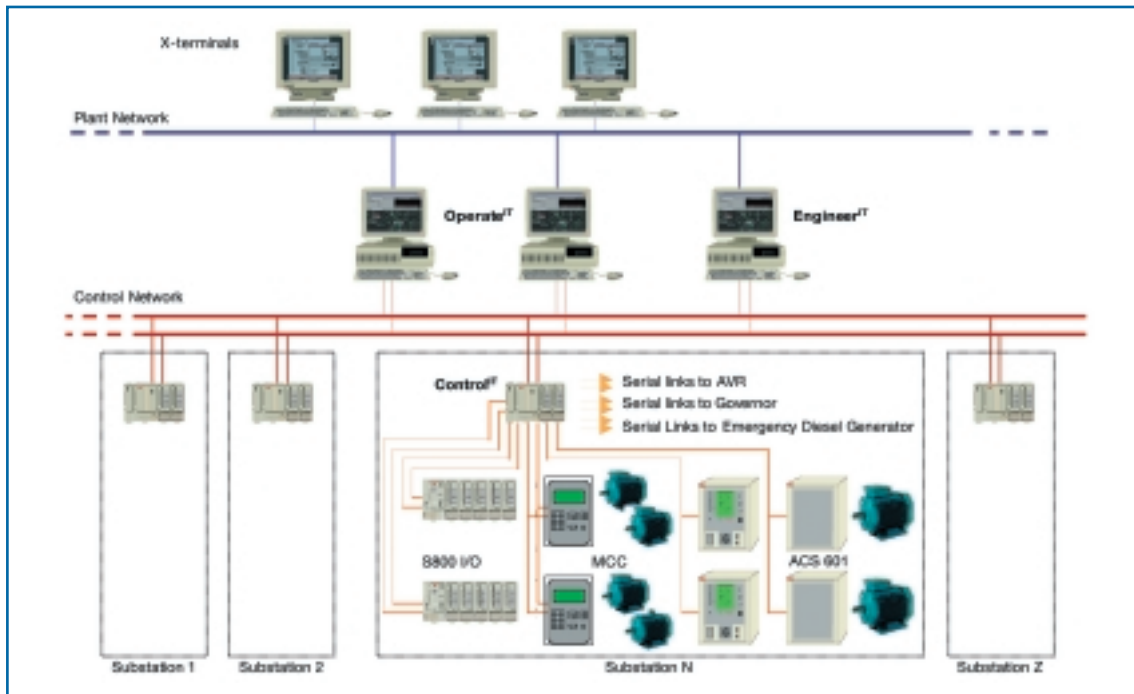

Configuration example of Industrial IT for Energy Management integrated with protection relays, Motor Control Centres, Governor Controllers and Process DCS.



ABB b.v.

Marten Meesweg 5
NL-3068 AV Rotterdam
Phone: +31 (0)10 4078622
Fax: +31 (0)10 4078458
E-mail: otto.wal@nl.abb.com