

Metallic Systems

SP Fitting Type C90



Technical Characteristics

Conforms to BSI Kitemark KM-35161
Low voltage directive
Inherent Low Fire Hazard

Approvals and Standards



Degree of mechanical protection

Very High

Degree of protection

IP65 - with all [Adaptasteel](#) liquid resistant conduit in the series

UV protection

Very High

Fitting characteristics



90° combined fitting & elbow

Application

For insertion into threaded entries & knockouts using a locknut

Normal operating temperature range

Application	Min Temp	Max Temp
Static	- 50°C	+300°C
Dynamic	- 45°C	+250°C

For use with - Conduit series

Type [SP](#), [SN](#) & [LFH-SP](#)

Fire performance

Test Standard

Performance Rating

EN45545	ILFH
NFF16-101	ILFH
LUL-1085	ILFH
BS6855	ILFH
DIN 5510-2	ILFH



Testing data

Click or see page [3](#)

Type of material

Nickel Plated Brass

Image



Metallic Systems

SP Fitting Type C90



Dimensional Data

Part No	Thread A	Nominal Dimensions (mm)				F
		B	C	D	E	
SP16/M16/C90	M16 x 1.5	12.5	38.0	35.0	11.1	25.4
SP16/M20/C90	M20 x 1.5	12.5	38.0	35.0	14.9	25.4
SP20/M20/C90	M20 x 1.5	12.5	39.0	36.0	14.9	28.5
SP25/M25/C90	M25 x 1.5	13.5	45.0	40.0	18.2	35.0
SP32/M32/C90	M32 x 1.5	17.5	53.0	48.0	24.8	42.0

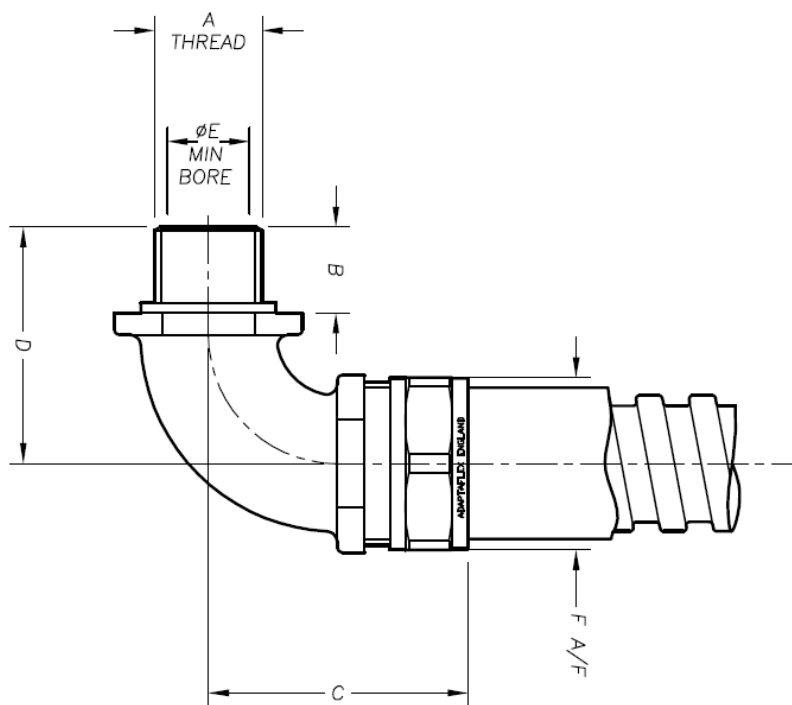

Cable Management Products Ltd.

CMG House - Station Road - Coleshill - B46 1HT - United Kingdom

Tel: +44(0)1675 468 222 - Fax: +44(0)1675 464 930

Technical Support e-mail: cmg.conduitsystems@abb.com - www.adaptaflex.com

Metallic Systems

SP Fitting Type C90



Chemical Resistance Chart

Key:

Suitable :



Limited Suitability :



Unsuitable :



Not Tested :



Astm No.1	Diesel oil	Methyl Bromide	Sulphur Dioxide (Gas)
Astm No.2	Diethylamine	MEK	Sulphuric Acid (10%)
Astm No.3	Ethanol	Nitric Acid (10%)	Sulphuric Acid (70%)
Acetic Acid (10%)	Ether	Nitric Acid (70%)	Toluene
Acetone	Ethylamine	Oxalic Acid	Transformer Oil
Aluminium Chloride	Ethylene Glycol	Ozone (Gas)	1,1,1-Trichloroethane
Aniline	Ethyl Ethanoate	Paraffin oil	Trichloroethylene
Benzaldehyde	Freon 32	Petrol	Turpentine
Benzene	Hydrochloric Acid (10%)	Phenol	Vegetable Oil
Carbon tetrachloride	Hydrochloric Acid (36%)	Sea Water	Vinyl Acetate
Chlorine water	Hydrogen Peroxide (35%)	Silver Nitrate	Water
Chloroform	Hydrogen Peroxide (87%)	Skydrol	White Spirit
Citric Acid	Lactic Acid	Sodium Chloride	Zinc Chloride
Copper Sulphate	Lubricating oil	Sodium Hydroxide (10%)	
Cresol	Methanol	Sodium Hydroxide (60%)	

The information above is given as a guide only and is based on published technical data and experience. The chemical resistance of the above products is dependant on factors such as chemical exposure, concentration of the chemical and temperature. The above chemicals are valid for a temperature of 23°C. Use of the above table is at the users own discretion and risk. Those using it must satisfy themselves that their application presents no health and safety risks. The end user should assess compatibility with their application and contact Thomas & Betts for further information.

ADHERENCE TO THE CURRENT WIRING REGULATIONS BS7671 OR NEC WIRING REGULATIONS (FOR USA) IS STRONGLY ADVISED.

MINIMUM BEND RADIUS FOR FLEXING IS DEPENDANT UPON MINIMUM TEMPERATURE, BENDING FREQUENCY AND CHEMICAL ENVIRONMENT.

Thread Data

Metric	Standard thread conforming to EN60423 & BS3643			
	Thread Size mm	Ext Thread Outside Diameter	Int Thread Inside Diameter	Pitch
M16	16.0	14.4	1.5	
M20	20.0	18.4	1.5	
M25	25.0	23.4	1.5	
M32	32.0	30.4	1.5	

Cable Management Products Ltd.

CMG House - Station Road - Coleshill - B46 1HT - United Kingdom

Tel: +44(0)1675 468 222 - Fax: +44(0)1675 464 930

Technical Support e-mail: cmg.conduitsystems@abb.com - www.adaptaflex.com