

---

ELECTRONIC SHIFT OPERATIONS MANAGEMENT SYSTEM

# ABB Ability™ Asset Suite eSOMS

## Clearance tag sharing



---

**The tagout/lockout process is perhaps the most important and time-consuming function that a plant's operation and maintenance staff performs, because it is critical to both personnel and plant safety.**



# Overview.

Errors in the tagout/lockout process can result in work delays, safety stand-downs, regulatory fines and personnel injury or death. Automating this process can result in significant gains in both efficiency and safety.

This paper details the concepts behind, and the benefits of, applying tag sharing in the ABB Ability™ Asset Suite eSOMS Clearance module. The Asset Suite eSOMS Clearance module is designed to assist in implementing, controlling, and executing a plant's tagout/lockout procedure. The system enforces the logic of plant-specific procedures to ensure personnel compliance. Clearances facilitates access and linkage to equipment isolation, work status, and schedule information through interfaces to third-party work control, maintenance management, and scheduling software systems.

The system incorporates a revolutionary method for tag and lock sharing that has been proven to save a significant amount of manpower resources during both normal plant operation and outages, without compromising personnel or plant safety. This paper also reports actual user experiences with tag sharing, including a quantitative analysis of the results and an estimate of the cost savings that were realised.

eSOMS is designed such that personnel need only hang one tag per component per tagout. This design is implemented through a relational concept of folders and tagouts. In eSOMS, folders are used to store and manage one or more related tagouts.

In the example below, a folder for plant unit 1 non-outage tagouts has been expanded to reveal four related tagouts for the isolation of plant systems within that folder. Two simple rules apply, which form the basis for implementing eSOMS tag sharing:

1. A tag to be hung on equipment that is already tagged by another tagout within the same folder will not be issued another tag or physical locking device (i.e., the equipment will have only one physical tag).
2. A tag to be hung on equipment that is already tagged by another tagout within a different folder will be issued another tag or physical locking device (i.e., the equipment will have multiple physical tags).

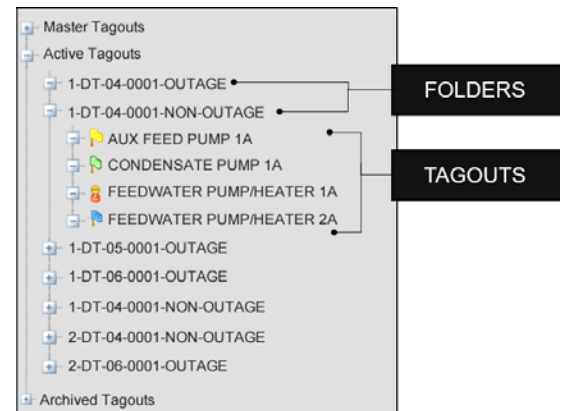

This simple but powerful concept is the basis for significant time and cost savings resulting from the elimination of duplicate, manpower-intensive, tag hang, removal, and audit activities. It also provides users the flexibility to implement a system that incorporates tag sharing, does not incorporate tag sharing, or incorporates a combination of both.

# Tag sharing in action.

The tag sharing concept can be illustrated with a simple example:

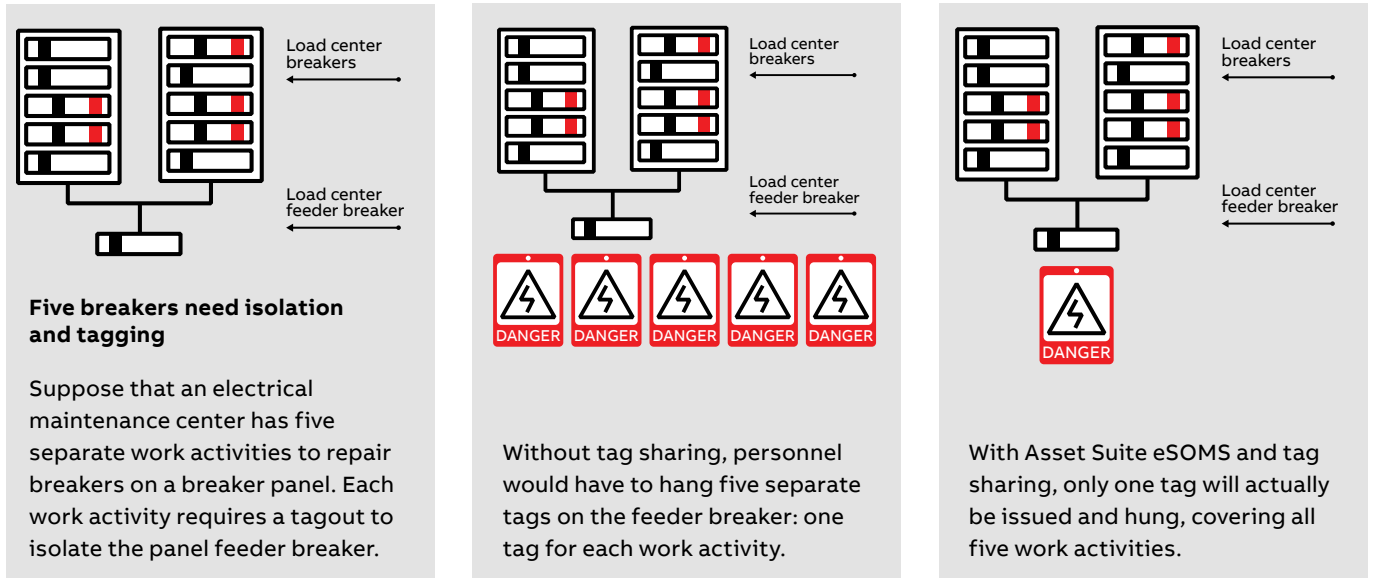

Though there will be only one physical tag hung, there will be five electronic tagouts preventing the tag from being removed. It is not until the last work activity is completed that the tag will be removed and the breaker returned to service. In this simple example, the elimination of four tags from the clearance process can represent a significant saving in real-world applications, considering the amount of time it can take to hang, verify hanging, remove, verify removal, and audit tags in the field.

Here's what real eSOMS users say about tag sharing:

‘...just completed first refueling outage using the eSOMS Clearance module. The tagging process went well, the best ever’.

“The system worked without a hitch throughout the outage and proved to be quite easy for the shops to learn and use’.

## Applications.

Although the benefits of tag sharing are obvious, not all Asset Suite eSOMS users can readily take advantage of this capability in the software. Since tag sharing relies upon the accurate and consistent identification of equipment being tagged, only eSOMS users that have a relatively rigorous and consistent equipment identification system will be able to fully implement a tag sharing environment.

In the illustration in the previous section, it is assumed that the feeder breaker is consistently identified across all work activities and tagouts for tag sharing to work correctly. If, for example, one of the tagouts identifies the feeder breaker as 1-BRK-1-1A and another tagout identifies it as BREAKER-1A, the software will interpret it as attempting to tag two different components and issue two tags instead of one. Although this is conservative from the standpoint of personnel and equipment safety, it is clearly not the most efficient method for accomplishing the task.

## User experience.

To gauge the effectiveness of tag sharing in the nuclear power industry, a questionnaire was sent out to eSOMS customers in the nuclear power industry. Users were asked to report their experience with tag sharing during major plant outages. The core data requested included:

- Total number of isolations processed – this includes both physical isolations and ‘electronic’ isolations from tag sharing
- Number of physical isolations processed – the actual number of physical tags hung

Based upon this information a tag share ratio was calculated:

$$\text{Tag share ratio} = \frac{\text{Number of physical isolations processed}}{\text{Total number of isolations processed}}$$

The tag share ratio is a measure of the percentage of tags hung with tag sharing versus the number of tags that would have been hung without tag sharing.

To estimate of the cost savings achieved as a result of the man-hours saved from not having to process the physical isolations eliminated by tag sharing, the following range of parameters were used:

- Time saved per isolation = 10-20 minutes\*
- Personnel costs = \$50-\$100 per hour

The estimated cost savings are reported as a range based upon the above parameters and the data reported. The cost savings do not include the avoidance cost of purchasing electricity for the days saved in a shorter outage.

**The survey results are reported in the following table and also include qualitative feedback from the users. For the purpose of confidentiality, actual customer or plant names are not reported.**

\*Includes first and second verifications on placement, first and second verifications on release, and tag auditing.

# Tag sharing survey results.

Plant type	Outage duration	Total # of isolations processed	# of physical isolations processed	Tag share ratio	Range of cost savings*	User comments
1-Unit BWR 1,095 MW	Not provided	18,366	11,157	61%	\$60,075 - 240,300	Not provided
2-Unit BWR 1,045 MW	31 days	15,806	6,068	38%	\$81,150 - 324,600	<ul style="list-style-type: none"> <li>• 'Substantial manpower and time savings over previous outages'.</li> <li>• 'Entire work force involved (Plant Manager on down), was quite impressed with the system and its results'.</li> <li>• 'Utilised the capability for the shops to sign themselves on/off as clearance/work order holders...worked very well... and greatly reduced the time required to obtain tag lists for walk-down and to sign on and off of clearances'.</li> <li>• 'The shop supervisors really liked being able to go into the system to get info on clearances and get tag lists, etc'.</li> <li>• 'The system worked without a hitch throughout the outage and proved to be quite easy for the shops to learn and use. In fact, we were unable to provide training for the shops until the outage started. We had a couple of hectic days but, the shop personnel picked it up quickly and we were on our way'.</li> </ul>
1-Unit BWR 1,205 MW	31 days	11,750	4,544	39%	\$60,050 - 240,200	Not provided
1-Unit BWR 670 MW	Not provided	14,957	5,176	35%	\$81,508 - 326,033	Not provided
2-Unit PWR 485 MW	59 days	19,720	3,960	20%	\$131,333 - 525,333	Not provided
2-Unit PWR 485 MW	36 days	13,630	2,571	19%	\$92,158 - 368,633	Not provided
2-Unit PWR 485 MW	32 days	7,420	1,981	27%	\$45,325 - 181,300	Not provided
2-Unit PWR 503 MW	26 days	7,700	2,102	27%	\$46,650 - 186,600	'The average number of tags hung in our 3 refueling outages prior to using eSOMS Clearances was 3670'.
1-Unit PWR 1,150 MW	27 days	14,860	5,110	34%	\$81,250 - 325,000	<ul style="list-style-type: none"> <li>• '...just completed first refueling outage using the eSOMS Clearance module. The tagging process went well, the best ever'.</li> <li>• 'We saw the time and man power savings of tag sharing. Additional time savings showed up when we needed add or change tagging boundaries to support additional work scope and schedule changes'.</li> <li>• 'The ability to efficiently reproduce a frequently used clearance, such as for a filter change-out, made life less stressful in the Tagging Office and helped reduce errors'.</li> <li>• 'The Tagging Office received less complaints from the Nuclear Systems Operators about the tagging system. Management was very happy and surprised at how well tagging went during the outage'.</li> <li>• 'The ability to conflict check on clearances 'Not Hung' paid off by essentially eliminating redoing clearances in the refueling outage due to conflicts discovered at time of 'Authorisation' or in the tag hanging process'.</li> <li>• 'Another thing we did prior to the outage with the help of our IT group was to copy the Production version of the Clearance Module to a Test region. We then got the Refueling Outage Tagging Office personnel together and went through the first 72 hours of our outage, electronically updating the clearances based on the outage schedule. This helped everyone visualise what would actually occur during the outage'.</li> </ul>
2-Unit PWR 1,148 MW	31 days	8,839	5,208	59%	\$30,258 - 121,033	'Tag sharing resulted in a significant savings in man-hours and manrem'.
2-Unit PWR 1,148 MW	43 days	10,945	7,245	66%	\$30,833 - 123,333	Not provided
1-Unit PWR 1,150 MW	35 days	14,732	3,649	25%	\$92,358 - 369,433	Not provided

\*USD

---

## Learn more.

To learn more about the benefits of tag sharing through Asset Suite eSOMS, contact ABB today!

[info.pges@abb.com](mailto:info.pges@abb.com)





—  
[abb.com/enterprise-software](http://abb.com/enterprise-software)  
[info.pges@abb.com](mailto:info.pges@abb.com)