

1SDH000460R0002 B2410

# Emax





# WARNING



**HAZARDOUS VOLTAGE  
CAN SHOCK, BURN  
OR CAUSE DEATH.**

Do not attempt to handle, install, use or service this product before reading instruction book

- READ THIS DOCUMENT AND THE INSTRUCTION MANUAL CAREFULLY BEFORE ATTEMPTING TO INSTALL, OPERATE OR SERVICE THIS CIRCUIT BREAKER.
- File these instructions with other instruction books, drawings and descriptive data of the circuit breaker.
- Keep this documents available for the installation, operation and maintenance about this equipment. Use of these instructions will facilitate proper maintenance of the equipment.
- Install the Circuit breaker within the design limitations as described in the Installation instructions shipped with the circuit breaker. These circuit breakers are designed to operate within the current and voltage limitations on the switch nameplate. Do not apply these switches to systems with current and/or voltages that exceed these limits.
- Follow your company's safety procedures.
- **Do not remove covers, open doors or work on equipment unless power has been turned off and all circuits de-energized, and after making sure of that with a measuring instrument.**



## WARNING:

- Detailed descriptions of standard repair procedures, safety principles and service operations are not included. It is important to note that this documents contain warnings and cautions against certain specific service methods that could cause personal injury to service personnel, damage equipment, or render it unsafe. These warnings do not cover all conceivable ways in which service, whether or not recommended by ABB, might be performed, or the possible hazardous consequences of each conceivable way, nor could ABB investigate all such ways.
- Anyone using service procedures or tools, whether or not recommended by ABB, must satisfy himself thoroughly that neither personal safety, nor equipment safety, will be jeopardized by the service method or tools selected. Should further information be required or specific problems arise that are not sufficiently covered, refer the matter to an ABB service representative.
- This publication is written only for qualified persons and is not intended to be a substitute for adequate training and experience in the safety procedures for this device.
- The purchaser, installer or ultimate user is responsible for ensuring that warning signs are attached and all access doors and operating handles are securely locked when the gear is left unattended, even momentarily.
- All information contained in this document is based on the latest product information available at the time of printing. We reserve the right to make changes at any time and without prior notice.

Dwg.		Resp. Off.		Title <b>Installation, service and maintenance instructions for low voltage air circuit-breakers</b>	Language
App.		Take over Off.			<b>EN</b>
Model	B2342	B2410		Apparatus <b>Emax</b>	Scale
<b>ABB</b>		<b>ABB SACE</b>		Doc. no.	<b>1SDH000460R0002</b>

# Index

1.	Description . . . . .	4	8.4.12.	Extractable . . . . .	27
1.1.	General characteristics. . . . .	4	9.	Measures to be taken for any operating anomalies .	28
1.2.	External front view of the circuit-breaker . . . . .	4	10.	Accessories. . . . .	29
1.3.	Rating plate . . . . .	4	10.1.	Electrical accessories . . . . .	29
1.3.1.	Circuit-breaker rating plate. . . . .	4	10.2.	Mechanical locks . . . . .	32
1.3.2.	Disconnecter rating plate . . . . .	4	10.3.	Notes for Emax LTT Low Temperature accessories .	33
1.4.	Moving part construction characteristics . . . . .	5	10.4.	Spare parts and retrofitting. . . . .	33
1.5.	Fixed part construction characteristics . . . . .	5	11.	Protection releases - General notes . . . . .	34
2.	Checking on receipt . . . . .	6	11.1.	Safety notes. . . . .	34
3.	Storage, lifting and weights . . . . .	6	11.1.1.	Notes for dielectric stiffness tests . . . . .	34
4.	Installation . . . . .	7	11.2.	Abbreviations and notes . . . . .	35
4.1.	Installation room . . . . .	7	11.2.1.	Abbreviations . . . . .	35
4.2.	Installation of the fixed circuit-breaker . . . . .	7	12.	SACE PR121/P RELAY . . . . .	36
4.3.	Installation of the fixed part of the withdrawable circuit-breaker . . . . .	7	12.1.	IDENTIFICATION . . . . .	36
4.3.1.	Preparation of the fixed part . . . . .	7	12.2.	Specifications. . . . .	36
4.3.2.	Installation of the fixed part (Fig. 12). . . . .	8	12.2.1.	General characteristics. . . . .	36
4.3.3.	Installation of the fixed part on board a ship (Fig. 11) .	8	12.2.2.	Compatibility CB . . . . .	37
4.4.	Installation of the flange on the compartment door (Fig. 13) . . . . .	8	12.2.3.	Standards . . . . .	37
5.	Electrical connections . . . . .	9	12.2.4.	Environmental characteristics . . . . .	37
5.1.	Connections to the power circuit . . . . .	9	12.2.5.	Electrical characteristics . . . . .	37
5.1.1.	Shapes of the terminals . . . . .	9	12.2.5.1.	Primary current . . . . .	37
5.1.2.	Examples of positioning the connection busbars according to the types of terminals . . . . .	9	12.2.5.2.	Power supply . . . . .	37
5.1.3.	Assembly procedure for the connection busbars . . . . .	11	12.3.	User interface . . . . .	38
5.2.	Earthing . . . . .	11	12.3.1.	Dip switches . . . . .	38
5.3.	Wiring the circuit-breaker auxiliary circuits . . . . .	11	12.3.2.	LED . . . . .	38
5.3.1.	Interfacing elements for fixed circuit-breakers . . . . .	11	12.3.3.	Rating Plug . . . . .	39
5.3.2.	Withdrawable circuit-breaker . . . . .	12	12.3.4.	iTest button . . . . .	39
5.4.	Conversion of the auxiliary contacts or of the signalling contacts (disconnected - test isolated - connected), from normally closed (opening) to normally open (closing) or vice versa . . . . .	13	12.3.5.	Test connector . . . . .	40
6.	Putting into service . . . . .	14	12.4.	PROTECTION FUNCTIONS. . . . .	40
6.1.	General procedures. . . . .	14	12.4.1.	Protection L. . . . .	40
7.	Instructions for use . . . . .	15	12.4.1.1.	Thermal memory L . . . . .	40
7.1.	Operating and signalling parts . . . . .	15	12.4.2.	Protection S. . . . .	40
7.2.	Circuit-breaker closing and opening procedures . . . . .	16	12.4.2.1.	Thermal memory S . . . . .	41
7.3.	Racking-in/out operation. . . . .	17	12.4.3.	Protection I . . . . .	41
8.	Maintenance . . . . .	19	12.4.4.	Protection G. . . . .	41
8.1.	Warning . . . . .	19	12.4.5.	Neutral Protection . . . . .	41
8.2.	Maintenance programme. . . . .	19	12.4.6.	Protection against instantaneous short-circuit "Iinst" .	42
8.2.1.	Switch life . . . . .	19	12.4.7.	Summary table of protections . . . . .	42
8.2.2.	Maintenance program . . . . .	20	12.4.8.	Trip curves . . . . .	42
8.3.	First level maintenance operations . . . . .	20	12.4.8.1.	Trip curves for functions L-I . . . . .	42
8.3.1.	Preliminary operations: . . . . .	20	12.4.8.2.	Trip curves for functions L-S( $t = k/I^2$ )-I . . . . .	43
8.3.2.	Checks and general cleaning: . . . . .	20	12.4.8.3.	Trip curves for functions L-S( $t=k$ )-I. . . . .	43
8.3.3.	Switch connections and connections between the switch and the control panel . . . . .	20	12.4.8.4.	Trip curves for function G . . . . .	44
8.3.4.	Dismantling tab and cap . . . . .	21	12.5.	Main functions . . . . .	44
8.3.5.	Mechanical control . . . . .	21	12.5.1.	Measurement . . . . .	44
8.3.6.	Electrical and mechanical accessories . . . . .	22	12.5.2.	Self-monitoring . . . . .	44
8.3.7.	Protection releases . . . . .	22	12.6.	Putting into service and recommendations . . . . .	45
8.3.8.	Test with SD Testbus2 (optional) . . . . .	22	12.6.1.	Installation . . . . .	45
8.3.9.	Maintenance operations; final checks . . . . .	22	12.6.2.	Connections . . . . .	45
8.3.10.	Interlock. . . . .	23	12.6.3.	CS and TC connection check . . . . .	45
8.4.	Second level maintenance operations. . . . .	23	12.6.4.	Connection of current sensor for external neutral. .	45
8.4.1.	Preliminary operations: . . . . .	23	12.7.	Parameter and default settings . . . . .	45
8.4.2.	General checks and cleaning: . . . . .	23	12.8.	Troubleshooting. . . . .	46
8.4.3.	Connections between the switch and the control panel .	23	12.8.1.	Troubleshooting. . . . .	46
8.4.4.	Dismantling the tab, cap and arcing chambers . . . . .	24	12.8.2.	In the case of a fault . . . . .	46
8.4.5.	Mechanical control . . . . .	25	12.9.	External units . . . . .	47
8.4.6.	Electrical and mechanical accessories . . . . .	25	12.9.1.	PR030/B. . . . .	47
8.4.7.	Checking contact wear . . . . .	25	12.9.2.	PR010/T. . . . .	47
8.4.8.	Protection releases . . . . .	26	12.9.3.	BT030-USB . . . . .	47
8.4.9.	Test with SD Testbus2 (optional) . . . . .	26	12.9.4.	EKIP T&P . . . . .	47
8.4.10.	Maintenance operations; final checks: . . . . .	27	12.9.5.	HMI030 . . . . .	47
8.4.11.	Interlock. . . . .	27	12.9.6.	Flex interface . . . . .	48
			12.9.6.1.	Notes about the HMI030 and Flex Interface connection	48
			12.9.7.	Ekip Connect . . . . .	48
			13.	Overall dimensions . . . . .	49
			14.	Circuit diagrams . . . . .	63

Model	B2342	B2410		Apparatus	<b>Emax</b>	Scale
				Doc. No	<b>1SDH000460R0002</b>	Page No 3/74

# 1. Description

## 1.1. General characteristics

The SACE Emax series of circuit-breakers and disconnectors consists of a steel sheet structure which houses the operating mechanism, the poles and the auxiliary parts. Each pole, insulated from the others, contains the circuit-breaking parts and the current transformer of the corresponding phase.

The structure of the poles differs according to whether the circuit-breaker is selective or current-limiting.

The fixed version circuit-breaker has its own terminals for connection to the power circuit; in the withdrawable version the circuit-breaker comprises the moving part of the apparatus, which is completed with a fixed part fitted with the terminals for connection to the power circuit of the installation. The moving part and the fixed part coupled by means of special contacts installed in the fixed part.

## 1.2. External front view of the circuit-breaker

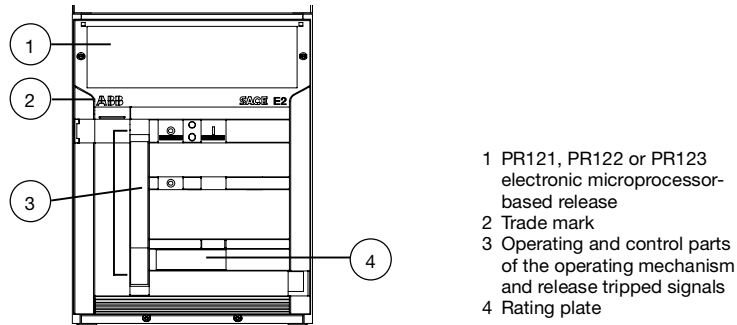

Fixed circuit-breaker

Fig. 1

## 1.3. Rating plate

### 1.3.1. Circuit-breaker rating plate

Switch example

<b>SACE E2B 16</b>	I <sub>u</sub> =1600A U <sub>e</sub> =690V I <sub>cw</sub> =42kAx1s					IEC 60947-2 made in Italy by ABB-SACE 
U <sub>e</sub> (V)	230	415	440	525	690	
I <sub>cu</sub> (kA)	42	42	42	42	42	
I <sub>cs</sub> (kA)	42	42	42	42	42	
cat. B	~ 50-60Hz					

Fig. 2a

### 1.3.2. Disconnector rating plate

Circuit-breaker example

<b>SACE E2B/MS 16</b>	I <sub>u</sub> =1600A U <sub>e</sub> =690V I <sub>cw</sub> =42kAx1s				IEC 60947-3 made in Italy by ABB-SACE 
U <sub>e</sub> (V)	400/415	690	250	500	
I <sub>e</sub> (kA)	1600	1600	1600	1600	
Cat.	AC - 23A		DC - 23A		
	~ 50-60Hz		1P --- 2P		

Fig. 2b

Model	B2342	B2410		Apparatus	<b>Emax</b>	Scale
				Doc. no.	<b>1SDH000460R0002</b>	Page No 4/74

### 1.4. Moving part construction characteristics

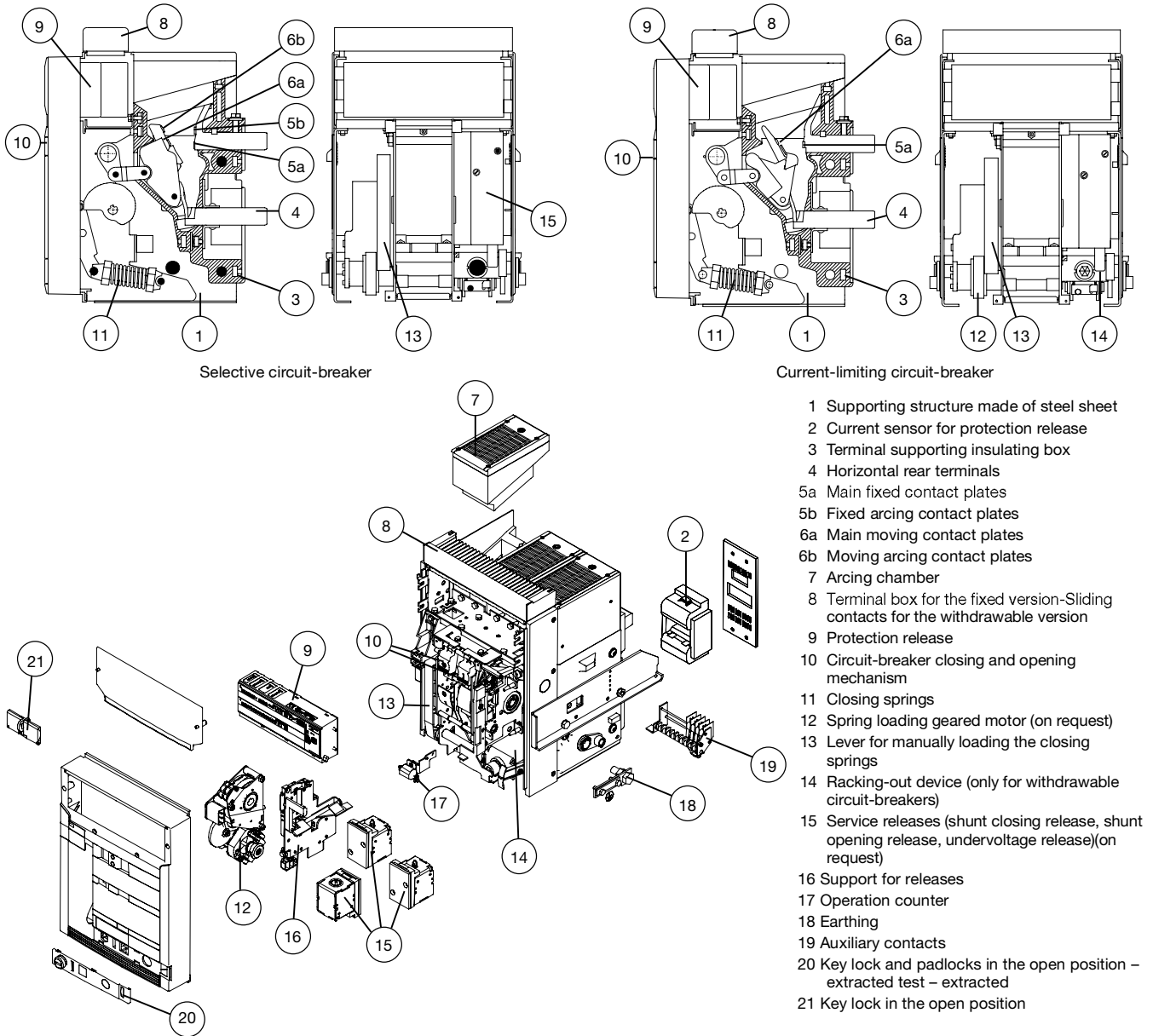

Fig. 3

### 1.5. Fixed part construction characteristics

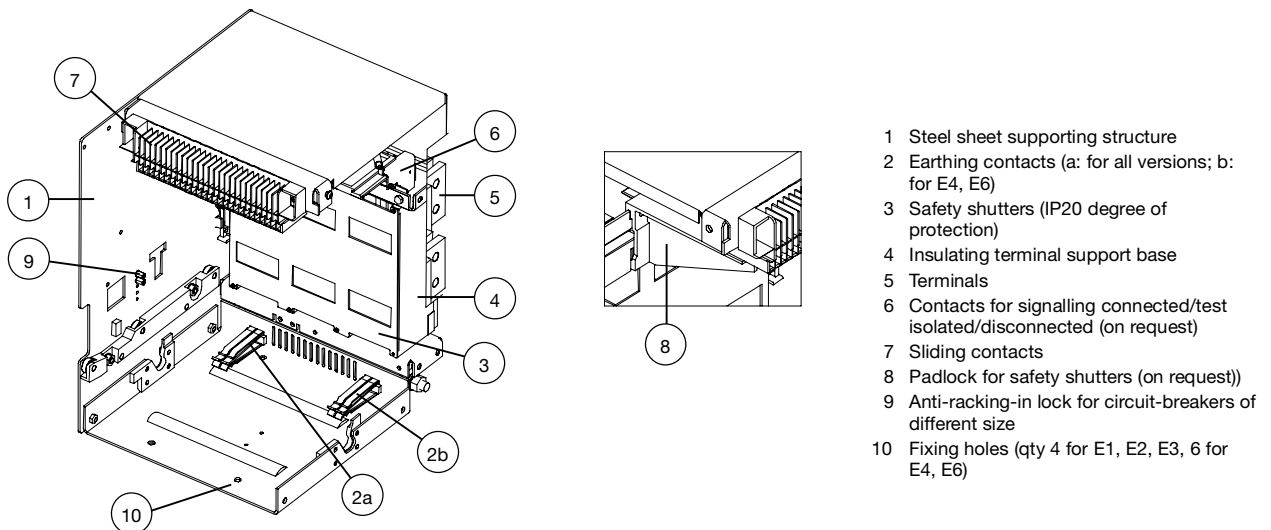

Fig. 4

Model	B2342	B2410		Apparatus	<b>Emax</b>	Scale
				Doc. No	<b>1SDH000460R0002</b>	Page No 5/74

## 2. Checking on receipt

Examine the state of the material received and its consistency with the content of the order. Should any damage or errors be found on unpacking, which must be carried out carefully, make the relative notification within and not over 5 days from the receipt of the material. The notification must indicate the number of the shipping note.

## 3. Storage, lifting and weights

The circuit-breaker, protected by an external wooden crate, is fixed by means of screws to the transport pallet or to the bottom of the packing case.

If the circuit-breaker has to remain in the warehouse even for a short time before being put into service, after checking it on receipt, it must be put back in its container and covered with a waterproof sheet.



### CAUTION:

- Use a dry, dust-free room free of aggressive chemical agents as a storage room,
- Storage temperature: -40°C ... +70°C
- Position the circuit-breaker and any fixed part on a horizontal surface, not in direct contact with the floor, but on a suitable support surface (Fig. 5);
- The maximum number of stackable circuit-breakers is indicated in figure 6,
- Keep the circuit-breaker in the open position and with the closing springs unloaded to avoid unnecessary stresses and the risk of accidents to the person.

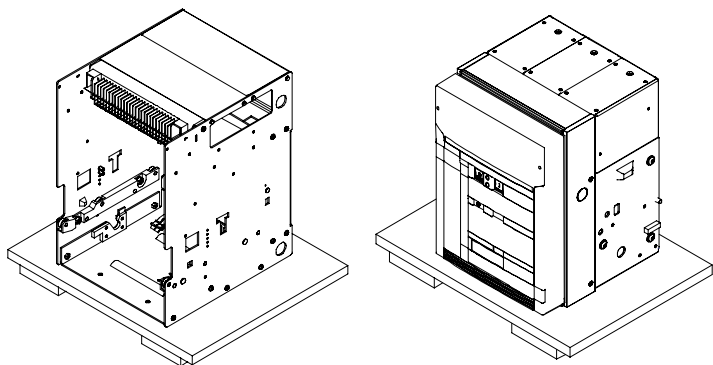

Fig. 5

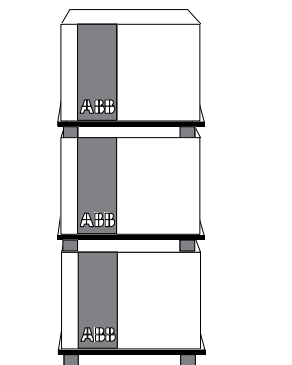

Fig. 6

With regard to lifting, follow the instructions: the circuit-breakers must be placed on a sturdy supporting surface and lifted, preferably, by means of a special fork-lift truck. However, the use of ropes is allowed. In this case, the lifting ropes must be hooked up as shown in the figures (the lifting plates are always supplied with the circuit-breaker).

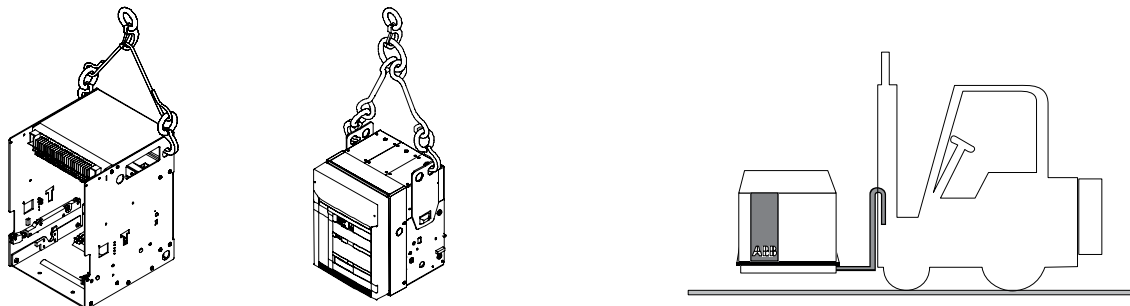

Fig. 7

Table of the circuit-breaker weights (Kg.)

Selective circuit-breaker	Fixed version		Withdrawable version	
	3 poles	4 poles	3 poles	4 poles
E1	45	54	70	82
E2	50	61	78	93
E3	66	80	104	125
E4	97	117	147	165
E4/f		120		170
E6	140	160	210	240
E6/f		165		250

Current limiting	Fixed version		Withdrawable version	
	3 poles	4 poles	3 poles	4 poles
E2L	52	63	80	95
E3L	72	83	110	127

### Notes:

- The weights indicated in the table are intended for circuit-breakers complete with PR121, PR122 or PR123 releases and relative current sensors, excluding the accessories.
- The withdrawable version includes the moving part in the same conditions as above, and the fixed part with horizontal rear terminals.

Model	B2342	B2410		Apparatus	<b>Emax</b>	Scale
				Doc. no.	<b>1SDH000460R0002</b>	Page No 6/74

## 4. Installation

### 4.1. Installation room

Install the circuit-breaker in a dry, dust-free, non-corrosive room, and in such a way that it is not subject to shocks or vibrations. Where this is not possible, install it inside a switchboard with a suitable degree of protection.

For the preparation of the installation room, please refer to the "Overall dimensions" paragraph, which gives information on the following points:

- minimum installation volumes of the circuit-breakers and derived versions
- distances to be respected for circuit-breakers in compartments
- overall dimensions of the circuit-breakers
- fixing drillings
- compartment door drillings.

The installation, commissioning and any ordinary and extraordinary maintenance have to be done by skilled personnel, with a detailed knowledge of the apparatus.

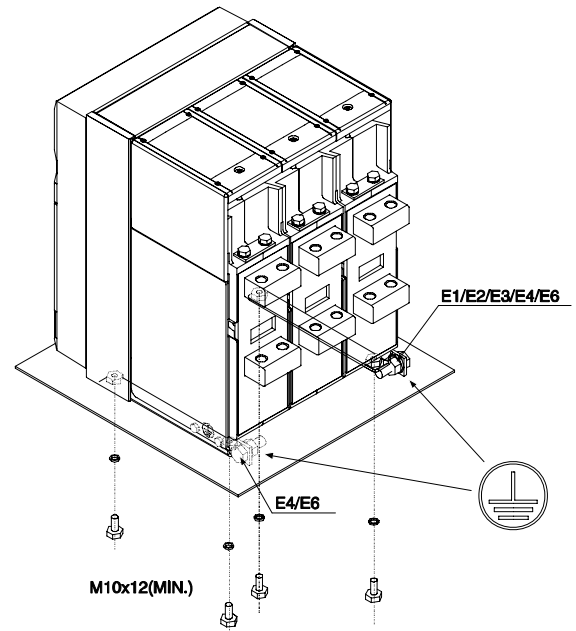

Fig.8



**WARNING: The installation, commissioning and any ordinary and extraordinary maintenance of the circuit-breaker and accessories must be performed by skilled personnel, with a detailed knowledge of the equipment.**



**WARNING ELECTRICAL SHOCK HAZARD: Disconnect and lock and tag out all electrical power feeds to avoid any potential shock hazard when you are assembling, installing maintaining or removing the circuit breaker from service. Some operations must be performed when the circuit-breaker is energized. In this case, reasonable care and compliance with all safe working practices is required.**

### 4.2. Installation of the fixed circuit-breaker

Fix the circuit-breaker to a horizontal surface using the screws (M10 x 12 min.).

### 4.3. Installation of the fixed part of the withdrawable circuit-breaker

#### 4.3.1. Preparation of the fixed part

##### Assembly of the anti-racking-in lock

Before installing the fixed part, it is necessary to check the presence of the anti-racking-in lock for circuit-breakers with different electrical characteristics from those of the fixed part. If the anti-racking-in lock has been supplied separately, proceed to assemble it as follows.

- On the self-adhesive plate (4), find the assembly position of the stop bolts in relation to the circuit-breaker which has to be housed in the fixed part.
- Insert the hexagonal-head screws (1) in the holes found in the previous item as shown in the figure.
- Fix the screws with the washers (2) and the hexagonal stops (3).

Make sure that the anti-racking-in lock corresponding to the one installed on the fixed part is present on the circuit-breaker (moving part).

- Anti-racking-in plate on the moving part (5).

Example for E1B 08 according to the nameplate diagram

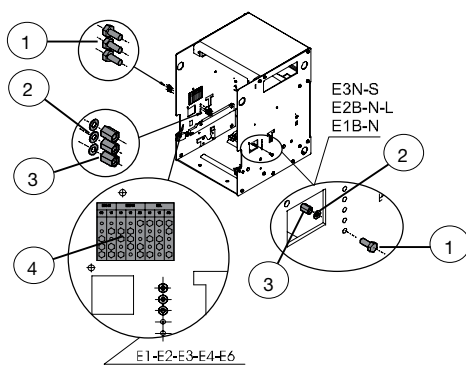

Fig. 9

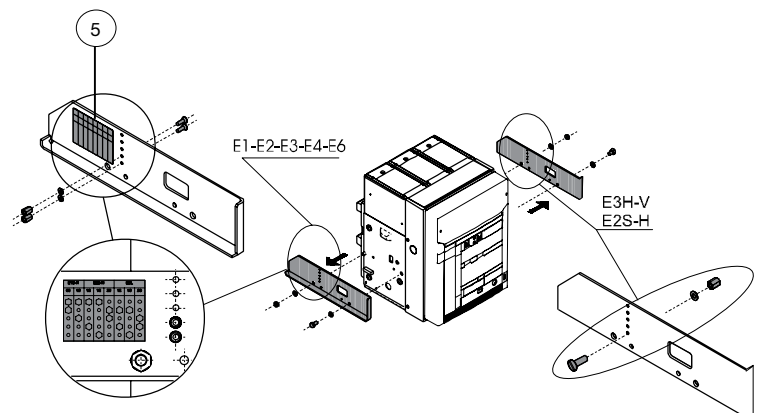

Fig. 10

Model	B2342	B2410		Apparatus	<b>Emax</b>	Scale
				Doc. No	<b>1SDH000460R0002</b>	Page No 7/74

#### 4.3.2. Installation of the fixed part (Fig. 12)

Attach the fixed part by means of the screws (1), washers (2) and nuts (3) (M8 x 16), supplied by ABB SACE. If other screws are used, make sure that the head of the screws does not extend more than 5.5 mm from the base of the fixed part.

#### 4.3.3. Installation of the fixed part on board a ship (Fig. 11)

Regarding the fixing points of the SACE Emax withdrawable version air circuit-breakers, for applications on board a ship, additional fixing on the sides of the fixed part itself is recommended (the M12 screws and the spacers are not provided in the supply).

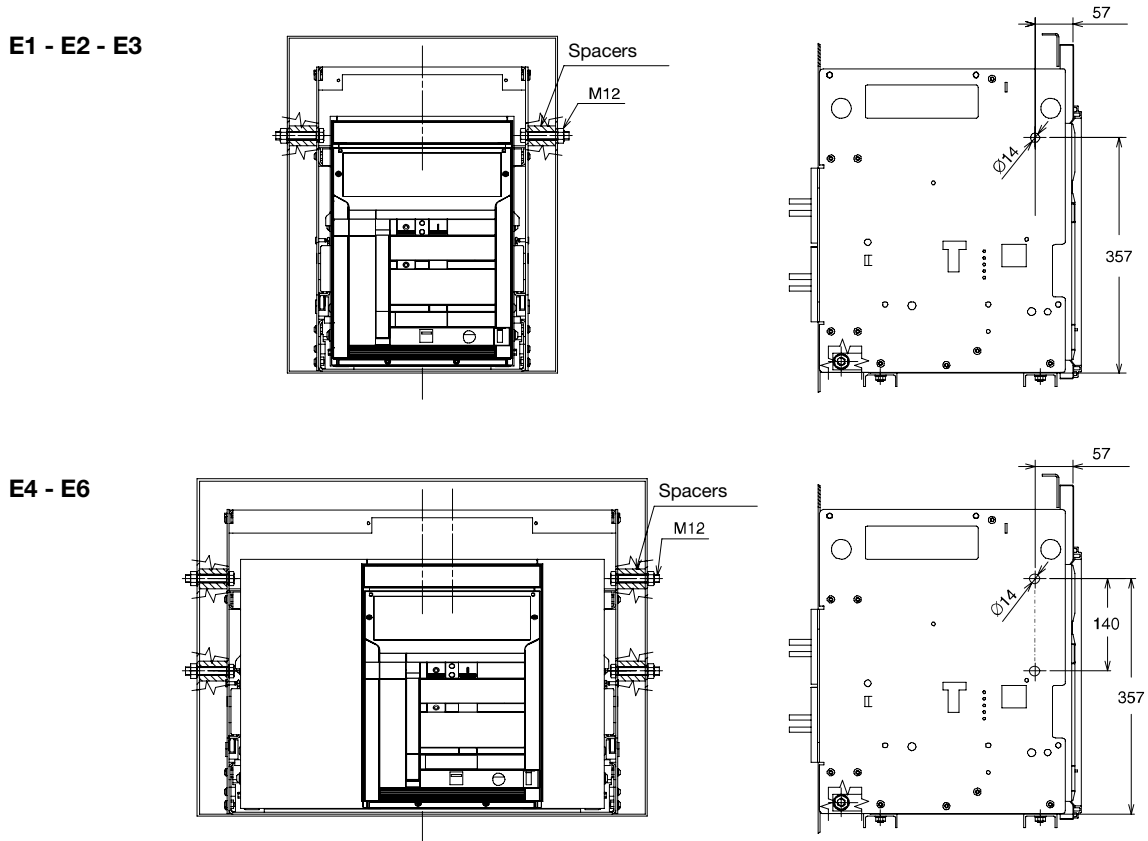
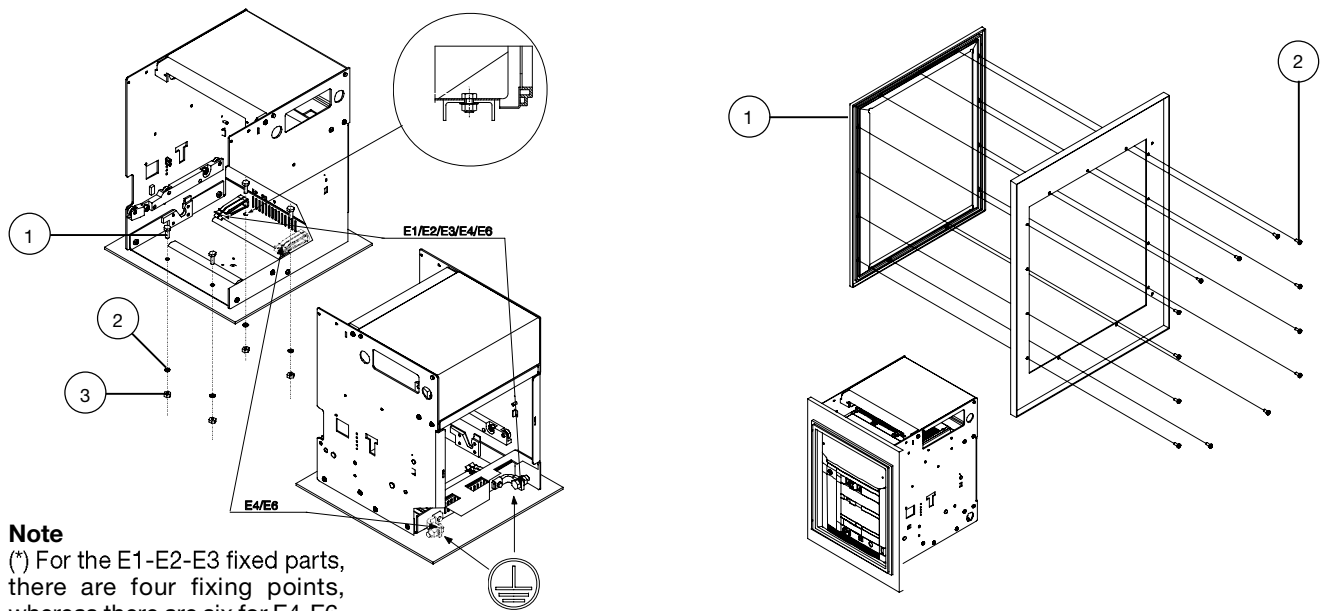

Fig. 11

#### 4.4. Installation of the flange on the compartment door (Fig. 13)

- Make the compartment door drillings specified in the "Overall dimensions" paragraph.
- Attach the flange (1) on the front of the compartment door, fixing it from the inside by means of the self-tapping screws (2).



**Note**  
 (\*) For the E1-E2-E3 fixed parts, there are four fixing points, whereas there are six for E4-E6.

Fig. 12

Fig. 13

Model	B2342	B2410		Apparatus	<b>Emax</b>	Scale
				Doc. no.	<b>1SDH000460R0002</b>	Page No 8/74



## 5. Electrical connections

### 5.1. Connections to the power circuit

#### 5.1.1. Shapes of the terminals

##### Fixed circuit-breaker

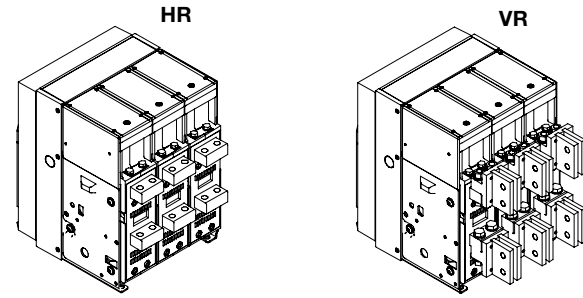

Horizontal rear terminals

Vertical rear terminals

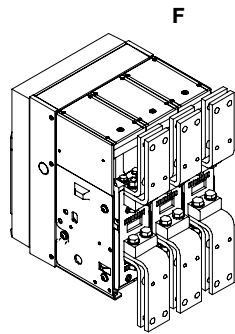

Front terminals

##### Fixed part for withdrawable circuit-breaker

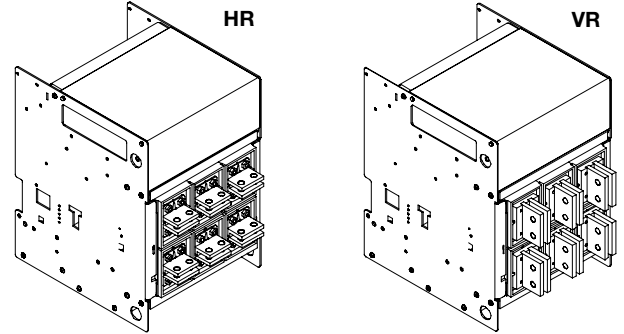

Horizontal rear terminals

Vertical rear terminals

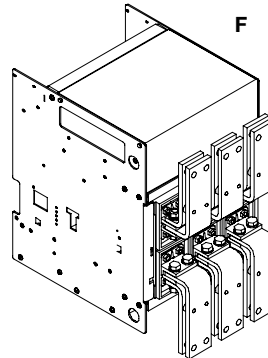

Front terminals

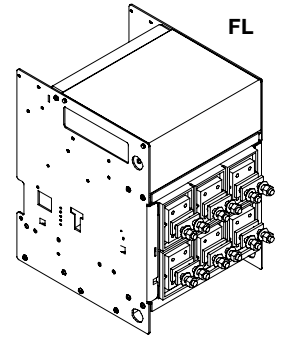

Flat terminals

Fig. 14

Fig. 15

#### Note

The drawings are provided to show the type of terminal in graphic form. The exact shape of the terminals is given in the "Overall dimensions" chapter.

#### 5.1.2. Examples of positioning the connection busbars according to the types of terminals

The connection busbars enable the connection between the terminals of the circuit-breakers and the busbars of the switchgear. Their sizing must be carefully studied by the switchgear designer. Some examples of possible constructions in relation to the shape and size of the circuit-breaker terminals are given in this paragraph. The various types of terminals are of constant dimensions for each size of circuit-breaker: it is normally advisable to exploit the whole contact surface of the terminal, so the width of the connection busbars should be the same as that of the terminal. Different connection capacities can be obtained by adjusting the thickness and number of busbars in parallel. In some cases, reductions in the width of the connection in relation to that of the terminal are allowable as shown in the following examples.

Circuit-breaker	I <sub>u</sub> [A]	Vertical terminals				Horizontal and front terminals				
		Continuous current-carrying capacity [A]			Busbar cross-section [mm <sup>2</sup> ]	Continuous current-carrying capacity [A]			Busbar cross-section [mm <sup>2</sup> ]	
		35°C	45°C	55°C		35°C	45°C	55°C		
<b>E1B/N 08</b>	800	800	800	800	1x(60x10)	800	800	800	1x(60x10)	
<b>E1B/N 10</b>	1000	1000	1000	1000	1x(80x10)	1000	1000	1000	2x(60x8)	
<b>E1B/N 12</b>	1250	1250	1250	1250	1x(80x10)	1250	1250	1200	2x(60x8)	
<b>E1B/N 16</b>	1600	1600	1600	1500	2x(60x10)	1550	1450	1350	2x(60x10)	
<b>E2S 08</b>	800	800	800	800	1x(60x10)	800	800	800	1x(60x10)	
<b>E2N/S 10</b>	1000	1000	1000	1000	1x(60x10)	1000	1000	1000	1x(60x10)	
<b>E2N/S 12</b>	1250	1250	1250	1250	1x(60x10)	1250	1250	1250	1x(60x10)	
<b>E2B/N/S 16</b>	1600	1600	1600	1600	2x(60x10)	1600	1600	1530	2x(60x10)	
<b>E2B/N/S 20</b>	2000	2000	2000	1800	3x(60x10)	2000	2000	1750	3x(60x10)	
<b>E2L 12</b>	1250	1250	1250	1250	1x(60x10)	1250	1250	1250	1x(60x10)	
<b>E2L 16</b>	1600	1600	1600	1500	2x(60x10)	1600	1500	1400	2x(60x10)	
<b>E3H/V 08</b>	800	800	800	800	1x(60x10)	800	800	800	1x(60x10)	
<b>E3S/H 10</b>	1000	1000	1000	1000	1x(60x10)	1000	1000	1000	1x(60x10)	

Model	B2342	B2410		Apparatus	<b>Emax</b>	Scale
				Doc. No	<b>1SDH000460R0002</b>	Page No 9/74

Circuit-breaker	I <sub>n</sub> [A]	Vertical terminals			Busbar cross-section [mm <sup>2</sup> ]	Horizontal and front terminals			Busbar cross-section [mm <sup>2</sup> ]
		Continuous current-carrying capacity [A]				Continuous current-carrying capacity [A]			
		35°C	45°C	55°C		35°C	45°C	55°C	
<b>E3S/H/V 12</b>	1250	1250	1250	1250	1x(60x10)	1250	1250	1250	1x(60x10)
<b>E3S/H/V 16</b>	1600	1600	1600	1600	1x(100x10)	1600	1600	1600	1x(100x10)
<b>E3S/H/V 20</b>	2000	2000	2000	2000	2x(100x10)	2000	2000	2000	2x(100x10)
<b>E3N/S/H/V 25</b>	2500	2500	2500	2500	2x(100x10)	2500	2450	2400	2x(100x10)
<b>E3N/S/H/V 32</b>	3200	3200	3100	2800	3x(100x10)	3000	2880	2650	3x(100x10)
<b>E3L 20</b>	2000	2000	2000	2000	2x(100x10)	2000	2000	1970	2x(100x10)
<b>E3L 25</b>	2500	2500	2390	2250	2x(100x10)	2375	2270	2100	2x(100x10)
<b>E4H/V 32</b>	3200	3200	3200	3200	3x(100x10)	3200	3150	3000	3x(100x10)
<b>E4S/H/V 40</b>	4000	4000	3980	3500	4x(100x10)	3600	3510	3150	6x(60x10)
<b>E6V 32</b>	3200	3200	3200	3200	3x(100x10)	3200	3200	3200	3x(100x10)
<b>E6H/V 40</b>	4000	4000	4000	4000	4x(100x10)	4000	4000	4000	4x(100x10)
<b>E6H/V 50</b>	5000	5000	4850	4600	6x(100x10)	4850	4510	4250	6x(100x10)
<b>E6H/V 63</b>	6300	6000	5700	5250	7x(100x10)	--	--	--	-

Fig. 16

### Positioning the first anchoring baffle of the busbars according to the short-circuit current

Anchoring to the switchgear

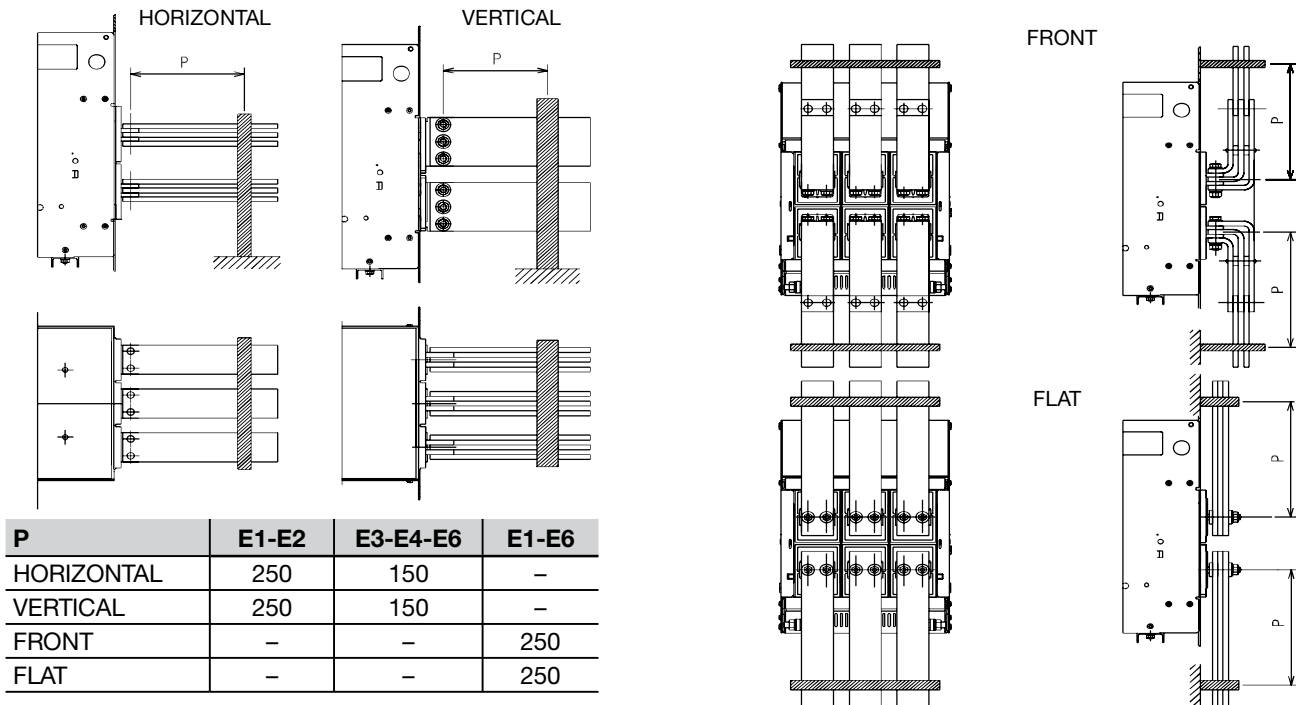

Fig. 17

Model	B2342	B2410		Apparatus	<b>Emax</b>	Scale
				Doc. no.	<b>1SDH000460R0002</b>	Page No 10/74

### 5.1.3. Assembly procedure for the connection busbars

Check the state of the contact surfaces of the connections very carefully: they must be very clean with no burrs, dents or traces of rust which must be eliminated using a fine file or an emery cloth to prevent localized increases in temperature. On completion of the operation, remove all traces of grease or dust with a cloth soaked in a suitable solvent. When aluminium connections the contact surfaces must be tinned.

The connections must not exert any strain on the terminals in any direction.

Always insert a large-diameter flat washer and a spring washer between them (to spread the tightening pressure over a greater area). Make the contact between connection and terminal and tighten the fixing screws completely.

Always use two wrenches (so as not to strain the insulating parts excessively), applying the tightening torque indicated in Fig. 18. Check tightness after 24 hours.

M12 high strength screws

Tightening torque of the main terminals: 70 Nm













Fixed part terminals	No. of screws for phase	No. of screws for neutral	Fixed circuit-breaker terminals	No. of screws for phase	No. of screws for neutral
	E1/E2 → 2	2		E1/E2 → 2	2
	E3 → 3	3		E3 → 3	3
	E4 → 4	2		E4 → 4	2
	E4/f → 4	4		E4/f → 4	4
	E6 → 6	3		E6 → 6	3
	E6/f → 6	6		E6/f → 6	6

Fig. 18

### 5.2. Earthing

The fixed circuit-breaker and the fixed part of the withdrawable circuit-breaker have one or two terminals on the rear, marked with the special symbol, for connection to earth (Fig. 9 and Fig. 12).

Each terminal is complete with a bolt for fixing the connection. A conductor with a cross-section conforming to current standards must be used for the connection.

Before assembling the connection, clean and degrease the area around the screw.

After the assembly, tighten the bolt with a torque of 70 Nm.

### 5.3. Wiring the circuit-breaker auxiliary circuits

#### 5.3.1. Interfacing elements for fixed circuit-breakers

A special terminal box is provided, fitted with screw terminals for connecting the auxiliary circuits.

The terminals are marked with alphanumerical identification codes as for the electrical circuit diagram.

The terminal box is identified by code XV on the electrical circuit diagram.

The terminal box is immediately accessible when the compartment door is open.

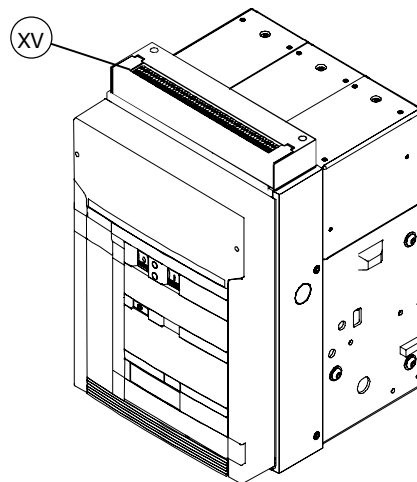

Fig. 19

Model	B2342	B2410		Apparatus	<b>Emax</b>	Scale
				Doc. No	<b>1SDH000460R0002</b>	Page No 11/74

### 5.3.2. Withdrawable circuit-breaker

For connection of the moving part to the auxiliary circuits, a connection with sliding contacts is available on the fixed part (see figure), identified by code X on the electrical circuit diagram.

The terminals of the fixed connector are immediately accessible when the compartment door is open.

Furthermore a terminal box identified by code XF is available for connecting the position contacts of the moving part in relation to the fixed part.

The connector and terminal box have screw terminals.

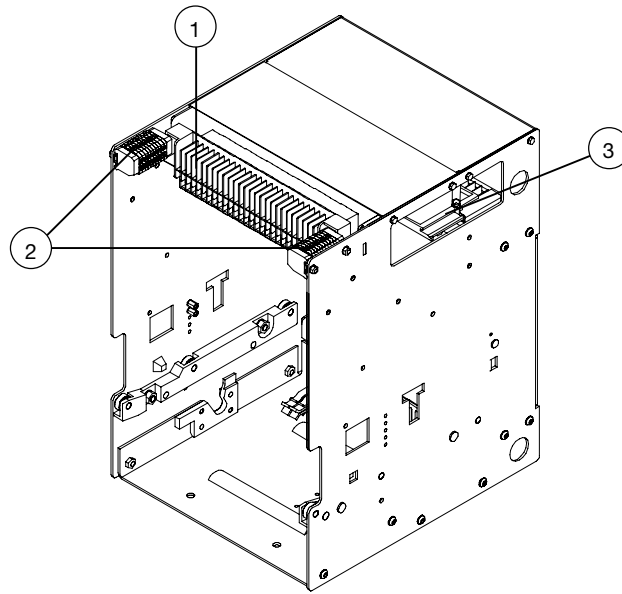

**E1 - E2 - E3**  
10 contacts in position

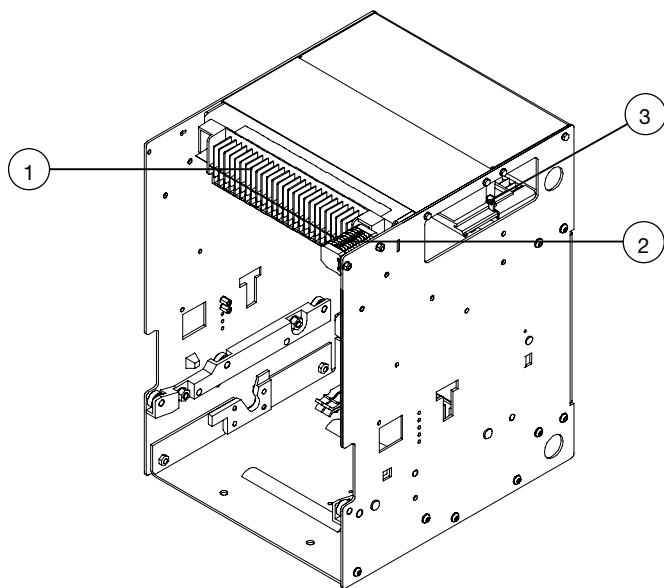

**E1 - E2 - E3 - E4 - E6**  
5 contacts in position

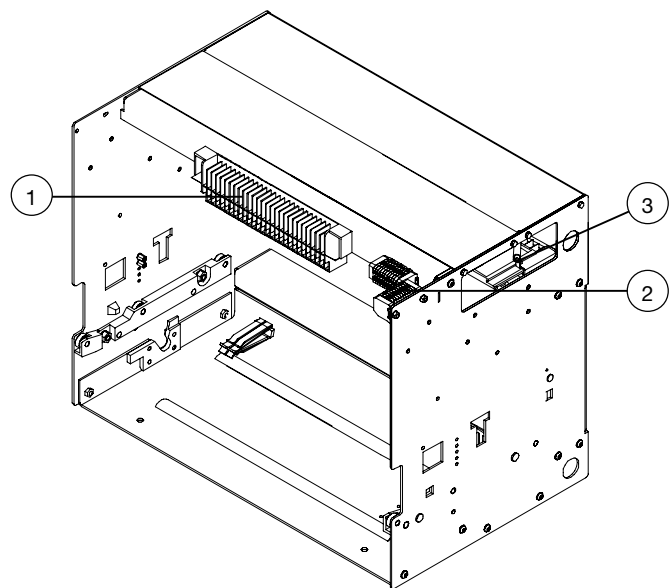

**E4 - E6**  
10 contacts in position

**Caption**

- 1 Sliding contacts (X)
- 2 Terminal box for position contacts (XF)
- 3 Position contacts

Fig. 20

Model	B2342	B2410		Apparatus	<b>Emax</b>	Scale
				Doc. no.	<b>1SDH000460R0002</b>	Page No <b>12/74</b>

5.4. Conversion of the auxiliary contacts or of the signalling contacts (disconnected - test isolated - connected), from normally closed (opening) to normally open (closing) or vice versa

The contacts are wired at the factory as shown on the electrical circuit diagram. If it is necessary to change their state for installation requirements, proceed as follows.

**a) Auxiliary contacts**

To access the auxiliary contacts, carry out the following operations:

- remove the front protection (3) of the release by taking action on the blocks (1) as shown in the figure
- remove the protection release (4) removing the side nuts (2) and then sliding the release out from the front of the circuit-breaker.

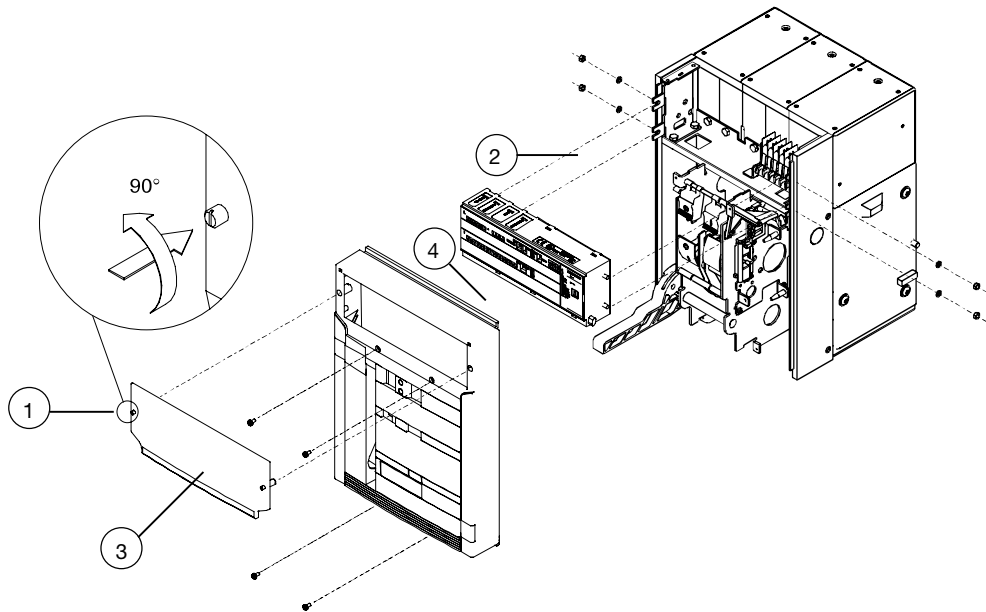
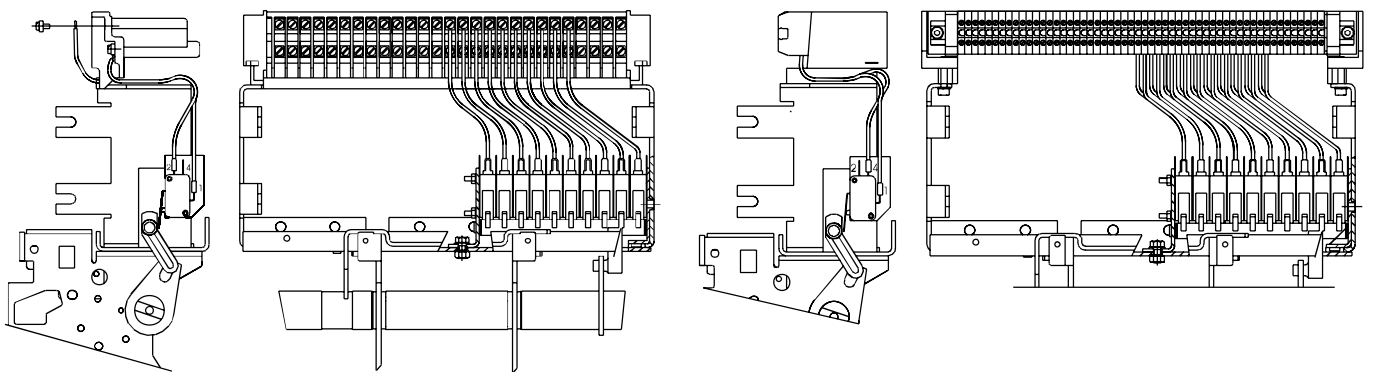

Fig. 21

Being of the two-way type (changeover contacts), the auxiliary contacts can be modified from break contacts to make contacts and vice versa simply by moving the output conductor from one position to the other, as shown in the figure (example for PR121).



N.C. contact

Sliding contacts

N.O. contact

Terminal box

Fig. 22

**b) Signalling contacts disconnected - test isolated - connected**

To change the state of the position contact, proceed in the same way as explained for the auxiliary contacts.

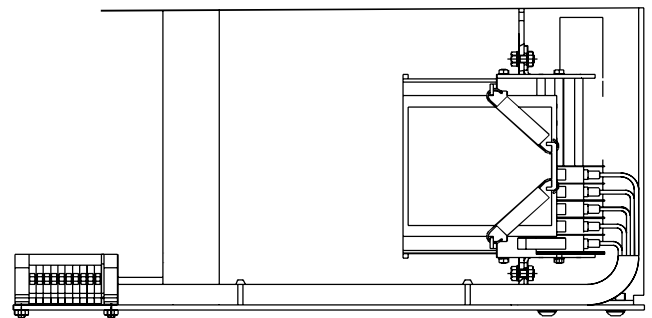

Model	B2342	B2410		Apparatus	<b>Emax</b>	Scale
				Doc. No	<b>1SDH000460R0002</b>	Page No 13/74

## 6. Putting into service

### 6.1. General procedures

- Check tightness of the power connections at the circuit-breaker terminals
- Carry out all the preparatory operations on the release
- Make sure that the value of the auxiliary circuit power supply voltage is between 85 and 110% of the rated voltage of the electrical applications
- Make sure that there is an adequate air circulation in the place of installation to avoid overheating
- Also carry out the checks specified in the following table.

Item inspected	Procedure	Positive check
1 Manual operating mechanism	Carry out some opening and closing operations (see the chapter 7.2). <b>CAUTION</b> <b>When there is an undervoltage release, the circuit-breaker can only be closed after the release has been electrically energized.</b>	The spring loading lever moves correctly
2 Geared motor (if any)	Supply the spring loading geared motor at the corresponding rated voltage.  Carry out some closing and opening operations.  Note. Supply the undervoltage release at the corresponding rated voltage (if any).	The springs are loaded correctly. The signals are correct. The geared motor stops with the springs loaded.  The geared motor reloads the springs after each closing operation.
3 Undervoltage release (if any)	Supply the undervoltage release at the corresponding rated voltage and carry out the circuit-breaker closing operation.  Disconnect voltage to the release. Supply the undervoltage release at the corresponding rated voltage and carry out the circuit-breaker closing operation.	The circuit-breaker closes correctly. The signals are correct.  The circuit-breaker opens. The signal changes over..
4 Shunt opening release (if any)	Close the circuit-breaker. Supply the shunt opening release at the corresponding rated voltage.	The circuit-breaker opens correctly. The signals are correct..
5 Shunt closing release (if any)	Open the circuit-breaker. Loading the springs. Supply the shunt closing release at its rated voltage.	The circuit-breaker closes correctly. The signals are correct.
6 Circuit-breaker lock in the open position (with key or padlocks)	Open the circuit-breaker, turn the key and remove it from its seat. Attempt circuit-breaker closing operation.	Both manual and electrical closing are prevented.
7 Auxiliary contacts of the circuit-breaker	Insert the auxiliary contacts in suitable signalling circuits. Carry out some circuit-breaker closing and opening operations.	The signals are given correctly..
8 Auxiliary contacts for signalling circuit-breaker connected, test isolated and disconnected	Insert the auxiliary contacts in suitable signalling circuits. Then put the circuit-breaker in the connected, test isolated and disconnected position.	The signals due to the relative operations are given correctly..
9 Lock devices for circuit-breakers connected and disconnected. Interlocking devices between circuit-breakers side by side and one on top of another (if any)	Carry out the operating tests.	The locks function correctly.
10 For withdrawable circuit-breakers: racking -in/out device	Carry out some racking-in and out operations.	Racking-in operation: the circuit-breaker racks in correctly. The first turns of the crank handle do not meet with particular resistance.



**WARNING: When undervoltage release has been activated by an undervoltage event, the circuit-breaker can only be closed after the release has been electrically energized. Ensure that an undervoltage condition existed at the time the release was activated. If not, investigate circuit-breaker and associated equipment to ensure they are in proper working order. If application is critical, investigate immediately.**

Model	B2342	B2410		Apparatus	<b>Emax</b>	Scale
				Doc. no.	<b>1SDH000460R0002</b>	Page No <b>14/74</b>

## 7. Instructions for use

### 7.1. Operating and signalling parts

- 1 Pushbutton for the manual opening operation
- 2 Lever for manual loading of the closing springs
- 3 Mechanical indicator for circuit-breaker open "O" and closed "I"
- 4 Mechanical indicator for protection release tripped (on request)
- 5 Pushbutton for the manual closing operation
- 6 Signalling device for springs loaded - unloaded
- 7 Operation counter (on request)
- 8 Key lock on the closing operation
- 9 Mechanical indicator for circuit-breaker connected, test isolated and disconnected
- 10 Seat for the racking-in/out lever
- 11 Lever releasing the racking-in/out operation
- 12 Key lock on the racking-in/out operation (on request)
- 13 Padlock on the manual closing operation (on request)
- 14 Padlock on the racking-in/out operation (on request)

Fixed circuit-breaker

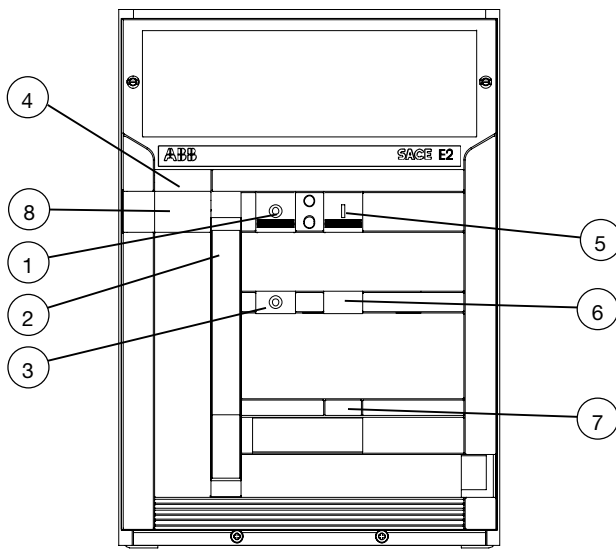

Withdrawable circuit-breaker

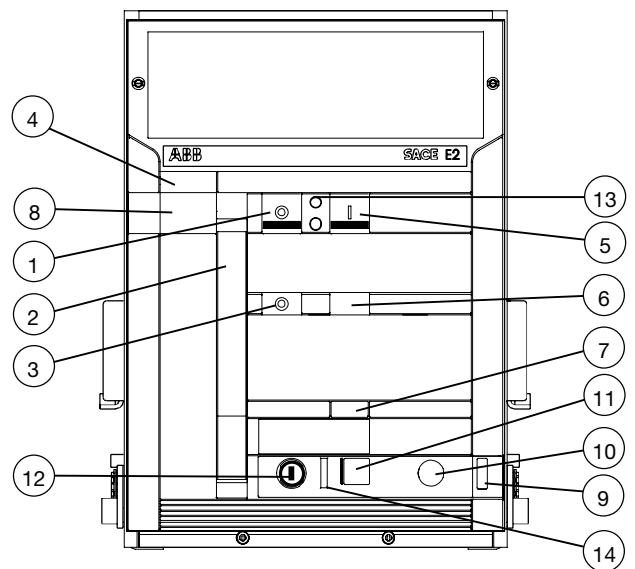

Fig. 23

**Note**

On request, a transparent cover can be installed on the front of the circuit-breaker to increase the degree of protection to IP54. The cover has a locking key.  
As an alternative to the transparent cover, a protection can be mounted on the manual closing and opening controls, which only allows operation of the pushbuttons by means of a special tool..

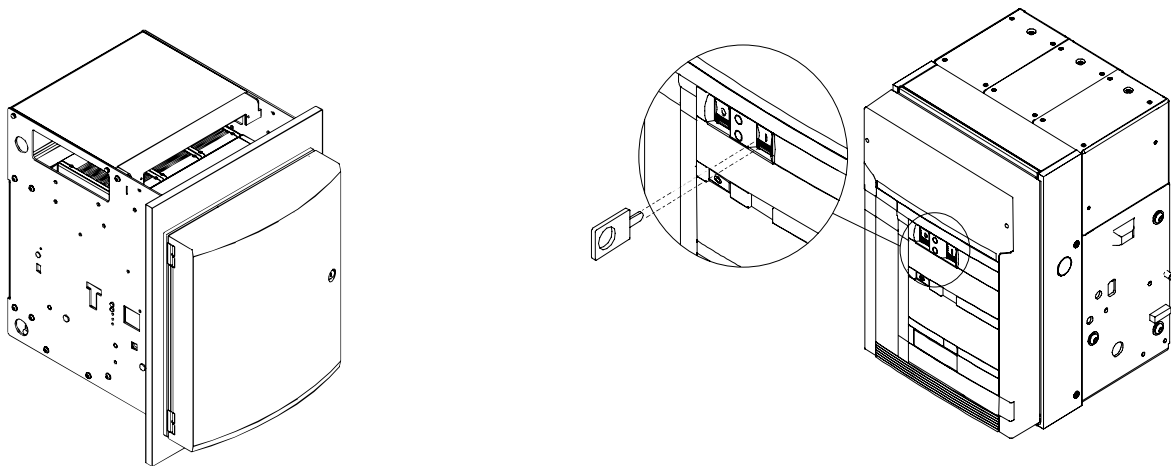

Fig. 24

Model	B2342	B2410		Apparatus	<b>Emax</b>	Scale
				Doc. No	<b>1SDH000460R0002</b>	Page No 15/74

## 7.2. Circuit-breaker closing and opening procedures

The operation of the circuit-breaker can be either manual or electrical.

### a) Manual loading of the closing springs

- Make sure that the indicator (3) shows "O" (circuit-breaker open)
- Make sure that the indicator (6) is WHITE (springs unloaded)
- Repeatedly activate the lever (2) until the indicator (6) changes its color to YELLOW

### b) Electrical loading of the closing springs

The electrical loading of the circuit-breaker is possible when the following accessories (supplied on request) are present:

- geared motor for automatic loading of the closing springs
- shunt closing release
- shunt opening release.

The geared motor automatically reloads the springs after each closing operation until the yellow indicator appears (6, Fig. 25). When the power is cut off during loading, the geared motor stops and automatically starts reloading the springs again when the power returns. It is, in any case, always possible to complete the reloading operation manually.

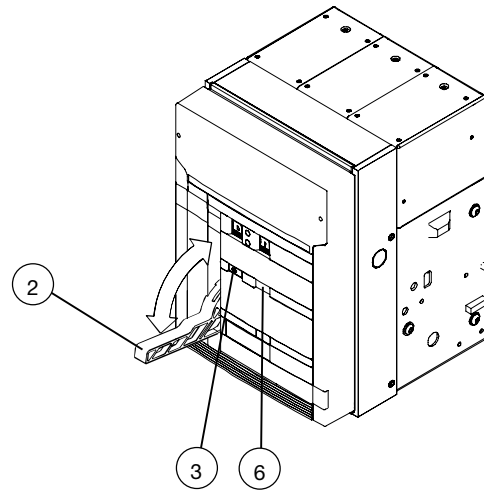

Fig. 25

### c) Closing the circuit-breaker

The operation can only be carried out with the closing springs fully loaded. For manual closing, press the pushbutton (5) marked with the letter "I". When there is a shunt closing release, the operation can be carried out remotely by means of the special control circuit. The special indicator (3) changes to indicate "I" to signal that the circuit-breaker has closed. Furthermore, the indicator of the state of the springs (6) goes to the WHITE position. Even with the closing springs unloaded, the operating mechanism retains enough energy for the opening operation. The geared motor, if any, immediately starts the automatic spring reloading operation.

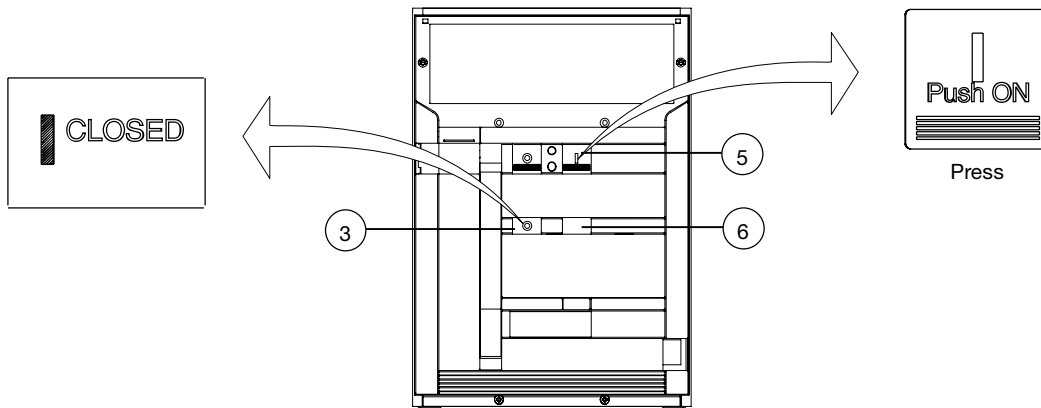

Fig. 26

### d) Opening the circuit-breaker

For manual opening of the circuit-breaker, press pushbutton "O" (1). When there is a shunt opening release, the operation can also be carried out remotely by means of the special control circuit. Opening having taken place is signaled by the letter "O" appearing in the indicator (3).

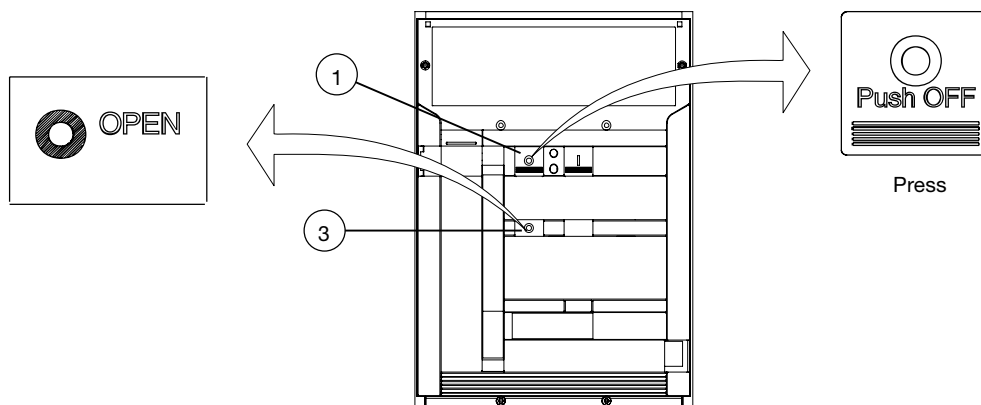

Fig. 27

Model	B2342	B2410		Apparatus	<b>Emax</b>	Scale
				Doc. no.	<b>1SDH000460R0002</b>	Page No <b>16/74</b>



### 7.3. Racking-in/out operation



**WARNING:**

- A) Open the circuit-breaker before carrying out any racking-in/out operation.
- B) The circuit-breaker (moving part) and fixed part are fitted with a lock which prevents the fixed part from being racked into the circuit-breakers with a different rated current: the congruence of the anti-racking-in lock must be checked by the operator before carrying out the racking-in operation to avoid any unnecessary stress.
- C) Before the racking-in operation, remove any padlock on the segregation shutter of the isolation terminals on the fixed part.



**WARNING ELECTRICAL SHOCK HAZARD:** Ensure that the circuit-breaker is either disconnected from all power sources and that the circuit breaker is open before performing any racking-in/out operation.

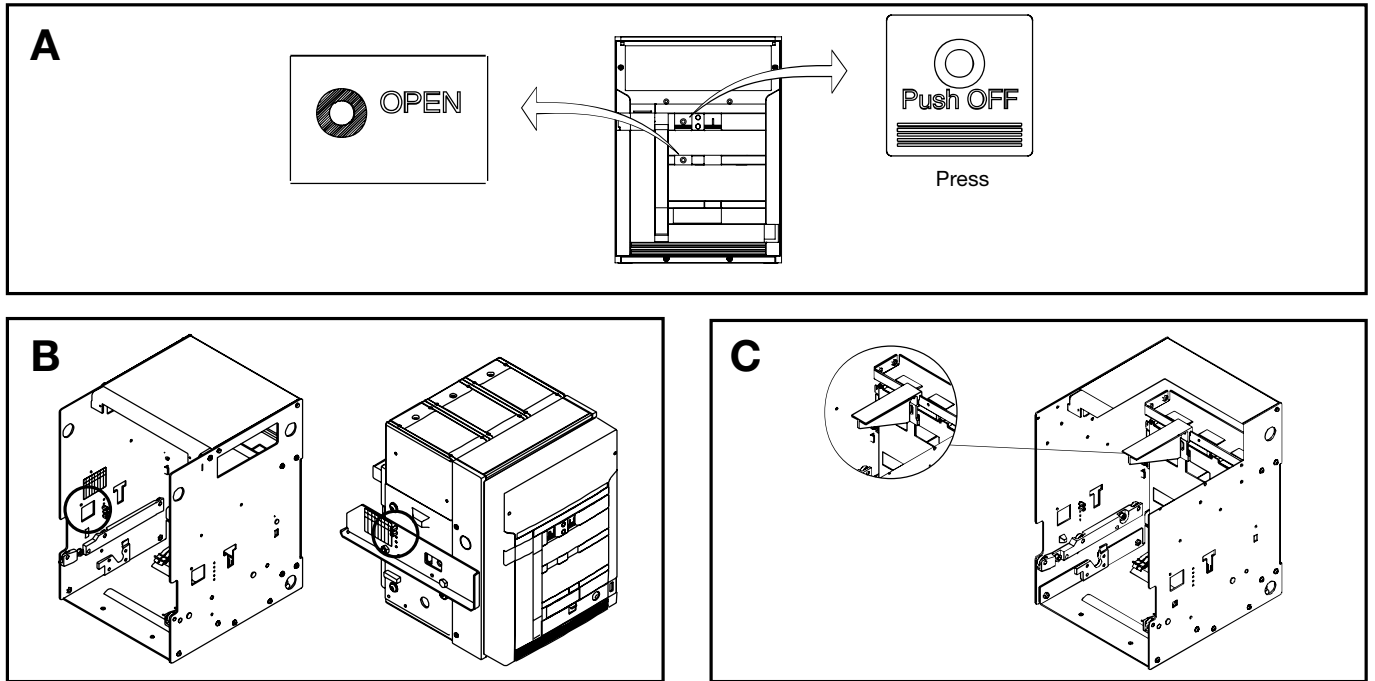

Fig. 28

**NOTE**

In relation to the fixed part, the circuit-breaker (moving part) can take up different positions, identified as follows:

- DISCONNECTED: the moving part is inserted in the fixed part WITHOUT any connection between the power terminals and WITHOUT coupling the sliding contacts for the auxiliary circuits: in this position all electrical operation of the circuit-breaker is prevented. On the front the indicator (9, Fig. 23) indicates DISCONNECTED. The switchgear compartment door can be closed.
- TEST ISOLATED: the moving part is inserted in the fixed part WITHOUT any connection between the power terminals, but WITH the sliding contacts coupled for the auxiliary circuits. In this position, the circuit-breaker can be operated for the offline tests. The indicator (9, Fig. 23) indicates TEST ISOLATED.
- CONNECTED: the moving part is fully inserted in the fixed part WITH the connection of both the power terminals and the sliding contacts for the auxiliary circuits. The circuit-breaker is operational. The indicator (9, Fig. 23) indicates CONNECTED.

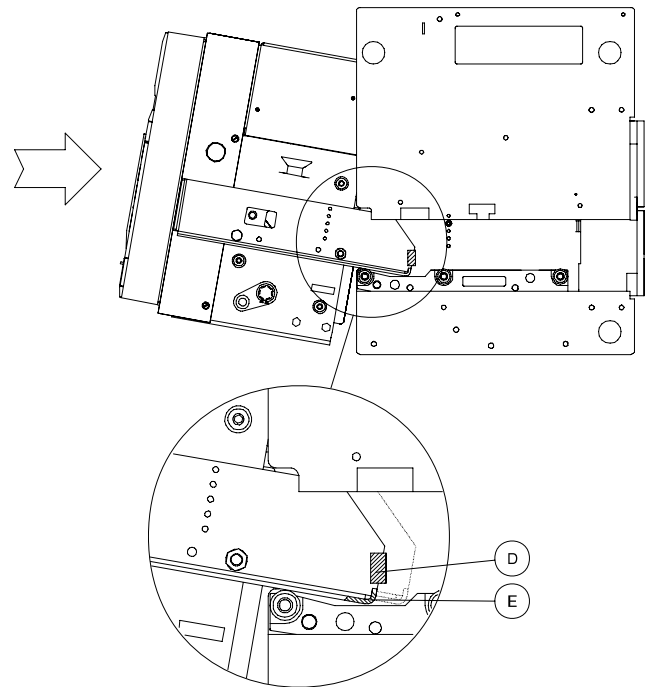

Fig. 29

Model	B2342	B2410		Apparatus	<b>Emax</b>	Scale
				Doc. No	<b>1SDH000460R0002</b>	Page No 17/74

**a) Positioning the moving part in the fixed part in the DISCONNECTED position**

Lift the moving part as shown in the paragraph (3) and insert it in the fixed part guide, tilting it as shown in figure 29.

The manual connection must allow the edge (E) of the circuit-breaker guide to slide under the blocks (D) of the fixed part. Remove the lifting devices.

Push the moving part as far as the stop in the fixed part.

Close the compartment door.

**b) Passing from the DISCONNECTED to the TEST ISOLATED position.**

- Make sure that the indicator (9) is in the DISCONNECTED position.

- For the connection procedure, make sure that the key (12) is in the correct position and/or the padlock (14), if any, has been removed.

- Make sure that the circuit-breaker is open.

- Push the moving part right into the fixed part.

- Lower the releasing lever (11).

- Insert the crank handle in the corresponding coupling (10).

- Proceed to turn the crank handle clockwise until the TEST ISOLATED indication appears on the indicator (9). During the initial turns, the crank handle must oppose no any particular resistance to rotation.

- Should it be necessary to carry out offline circuit-breaker operations, the crank handle must be removed.

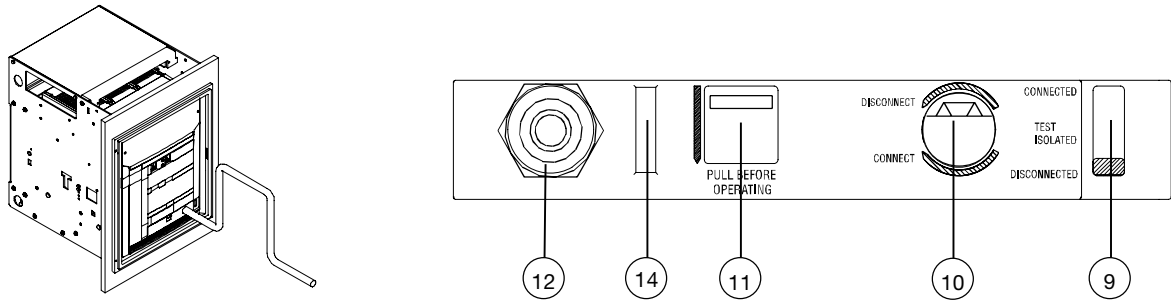

Fig. 30

**c) Passing from the TEST ISOLATED position to the CONNECTED position**

- Make sure that the circuit-breaker is open.

- Lower the releasing lever (11).

- Insert the crank handle in the corresponding coupling (10).

- Proceed to turn the crank handle clockwise until the CONNECTED indication appears on the indicator (9).

- Remove the crank handle to enable the circuit-breaker to close.

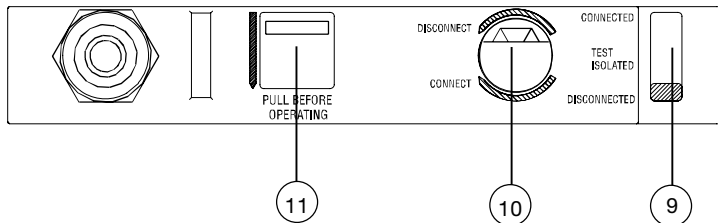

Fig. 31

**d) Passing from the CONNECTED position, to the TEST ISOLATED position, to the DISCONNECTED position**

- Repeat the connection procedures changing the direction for turning the crank handle to anti-clockwise. Open the door in the disconnected position.

Model	B2342	B2410		Apparatus	<b>Emax</b>	Scale
				Doc. no.	<b>1SDH000460R0002</b>	Page No <b>18/74</b>

## 8. Maintenance

### 8.1. Warning



**WARNING: Before carrying out any maintenance task, you must:**

- Open the circuit-breaker and check that the operating mechanism springs are unloaded;
- In the case of a withdrawable circuit breaker, remove the circuit breaker from the fixed part before working on it;
- For action on fixed version circuit-breakers or on fixed parts disconnect the power circuit and the auxiliary circuits and visibly earth the terminals both on the power supply side and on the load side;
- Make safe in compliance with current laws.



**WARNING ELECTRICAL SHOCK HAZARD: Shock Hazard or Injury.**

ABB declines all responsibility for damage to things and injury to people due to failure to comply with the instructions contained in this document. Maintenance tasks must be performed by qualified staff who are thoroughly familiar with the equipment.

### 8.2. Maintenance programme

#### 8.2.1. Switch life

With regular maintenance, SACE Emax circuit-breakers, either with or without opening or closing releases, can withstand the following operation without replacement of parts. <sup>(1)</sup>

Rated uninterrupted current		Mechanical life <sup>(2)</sup>		Electrical life <sup>(2)</sup>		
I <sub>u</sub> (40 °C) [A]		No. of operations x 1000	Frequency operations/hour	440 V ~ No. of operations x 1000	690 V ~ No. of operations x 1000	Free operations/hour
<b>E1 B-N</b>	800	25	60	10	10	30
	1000-1250	25	60	10	8	30
	1600	25	60	10	8	30
<b>E2 B-N-S</b>	800	25	60	15	15	30
	1000-1250	25	60	15	15	30
	1600	25	60	12	10	30
	2000	25	60	10	8	30
<b>E2 L</b>	1250	20	60	4	3	20
	1600	20	60	3	2	20
<b>E3 N-S-H-V</b>	800	20	60	12	12	20
	1000-1250	20	60	12	12	20
	1600	20	60	10	10	20
	2000	20	60	9	9	20
	2500	20	60	8	7	20
	3200	20	60	6	5	20
<b>E3 L</b>	2000	15	60	2	1,5	20
	2500	15	60	1,8	1,3	20
<b>E4 S-H-V</b>	3200	15	60	7	7	10
	4000	15	60	5	4	10
<b>E6 H-V</b>	3200	12	60	5	5	10
	4000	12	60	4	4	10
	5000	12	60	3	2	10
	6300	12	60	2	1,5	10
<b>Emax LTT - Low temperature version</b>						
<b>E1 B-N</b>	800-1600	8	60	8	8	30
<b>E2 B-N-S</b>	800-1600	8	60	8	8	30
<b>E2 L</b>	1250-1600	8	60	3	2	20
<b>E3 N-S-H-V</b>	800-2000	8	60	8	8	20
<b>E3 N-S-H-V</b>	2500	8	60	8	7	20
<b>E3 N-S-H-V</b>	3200	8	60	6	5	20
<b>E3 L</b>	2000-2500	8	60	1,6	1,3	20

(1) Data referring to standard installation conforming to product standards. For other applications, consult ABB Sace.

(2) Extreme atmospheric conditions, polluted atmosphere or vibrations may shorten the application's life. Consult ABB Sace.

Model	B2342	B2410		Apparatus	<b>Emax</b>	Scale
				Doc. No	<b>1SDH000460R0002</b>	Page No 19/74

### 8.2.2. Maintenance program

The table shows the maintenance intervals and the frequency of periodical intervention and routine maintenance tasks. The following rules should also be followed:

- Even circuit-breakers that are little used or remain on or off for long periods should be subject to the maintenance programme.
- For circuit breakers fitted with SACE PR121 installation of the mechanical operation counter (supplied on request) is recommended; the SACE PR122 and SACE PR123 releases with Vaux enable the number of operations performed by the circuit breaker in use to be displayed at any moment on the display.
- During operation, inspect the switch from the outside to check for dust, dirt or damage of any kind.

Maintenance operations	Interval	
	Installation in normal environments	Installation in dusty environments <sup>(1)/(2)</sup> and low temperature environment <sup>(3)</sup> [ (1) = level of measured dust > 1 mg/m <sup>3</sup> ]
<b>First level</b>	One year or 20% mechanical life or 20% electric life	6 months or 10% mechanical life or 10% electric life
<b>Second level</b>	Three years or 50% mechanical life or 50% electric life or after intervention on short circuit	18 months or 25% mechanical life or 25% electric life or after intervention on short circuit

(1) Data referring to standard installation in accordance with product standards. For other applications, consult ABB Sace.

(2) Extreme atmospheric conditions, polluted atmosphere or vibrations may shorten the life of the application. Consult ABB Sace.

(3) Emax LTT for low temperature environment application (-40°C ... +70°C)

### 8.3. First level maintenance operations

#### 8.3.1. Preliminary operations:

- open the switch and check that the control springs are unloaded
- in the case of a withdrawable circuit breaker, remove the circuit breaker from the fixed part before working on it

 **WARNING: before working on fixed switches or switches on fixed parts, disconnect the supply to the power circuit and to the auxiliary circuits and earth the terminals in a visible manner both on the supply and on the load side.**

#### 8.3.2. Checks and general cleaning:

- Check that the apparatus (switching part) is clean, removing dust and any traces of excess oil or grease using dry and clean rags (possibly using non-corrosive detergent).
- For excessive deposits, a laminated dilutant such as Henkel 273471 or the equivalent can be used.
- Check that the rating plates of the apparatus are in place.
- Clean the rating plates with dry and clean cloths.
- Eliminate any dust, mould, traces of condensation or oxidation also inside the fixed part of the apparatus if the switch is extractable.
- Check that there are no foreign bodies in the switch cabinet.

#### 8.3.3. Switch connections and connections between the switch and the control panel

- Use brushes and dry cloths to remove any dust or dirt (if necessary, use non-corrosive detergent).
- For excessive deposits, a laminated dilutant such as Henkel 273471 or the equivalent can be used.
- Check that there are no traces of overheating on the terminals. This problem is due to discolouring of the contact parts; the contact parts are normally silver in colour.
- Check that the bolts fixing the connections to the terminals are tight (M12 - 70Nm).

 **WARNING: before working on fixed switches or switches on fixed parts, disconnect the supply to the power circuit and to the auxiliary circuits and earth the terminals in a visible manner both on the supply and on the load side.**

- Check that the connecting screws of the cables of the terminal boards are tight (0.7 Nm).

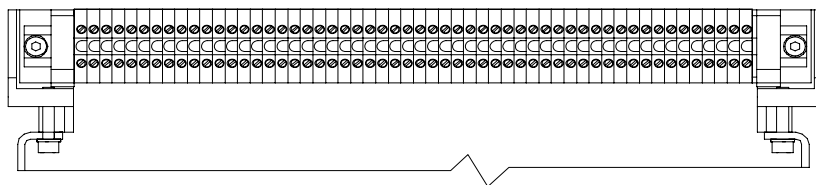

Fig. 32

Model	B2342	B2410		Apparatus	<b>Emax</b>	Scale
				Doc. no.	<b>1SDH000460R0002</b>	Page No <b>20/74</b>

### 8.3.4. Dismantling tab and cap

- The tab (1) of the release by rotating the screws (2) as shown in figure 33.
- Remove the front cap (3) by loosening the four screws (4).

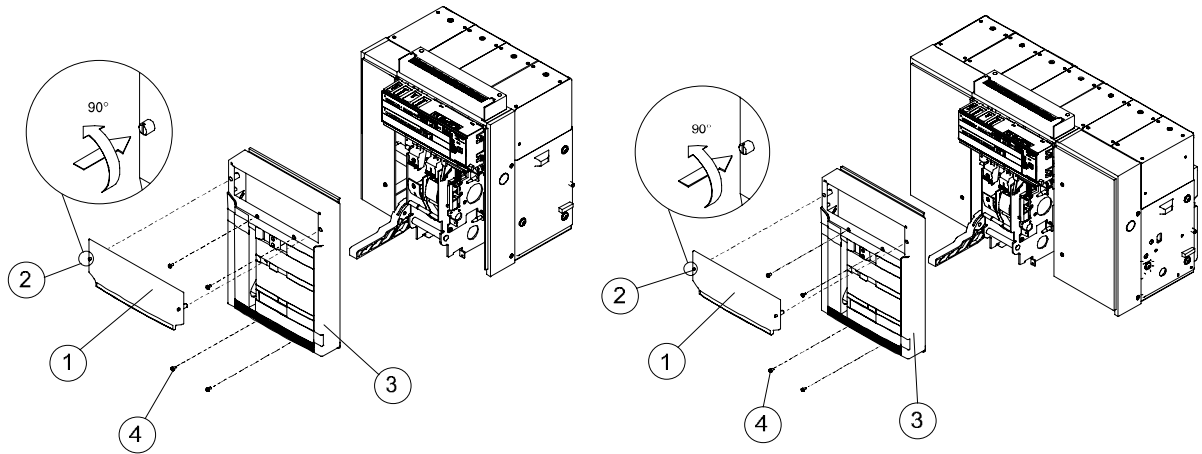

Fig. 33

- If there is a minimum release, remove the coils support and release the control springs, closing and opening the switch.

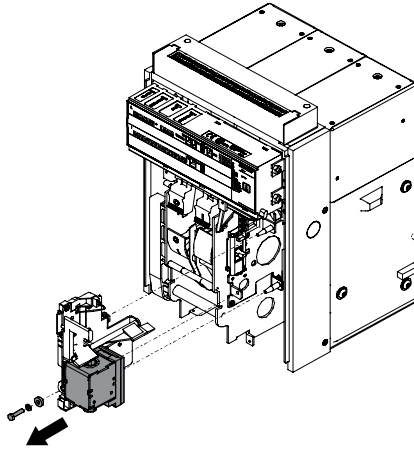

Fig. 34

### 8.3.5. Mechanical control

- Clean at the points indicated in figure 35. For excessive deposits, a laminated dilutant such as Henkel 273471 or the equivalent can be used.
- Lubricate, at the points indicated in fig. 35, the opening-closing shafts and hooks with MOBILGREASE 28 (EXXON MOBIL).
- Check that the opening and closing shafts are free to rotate.

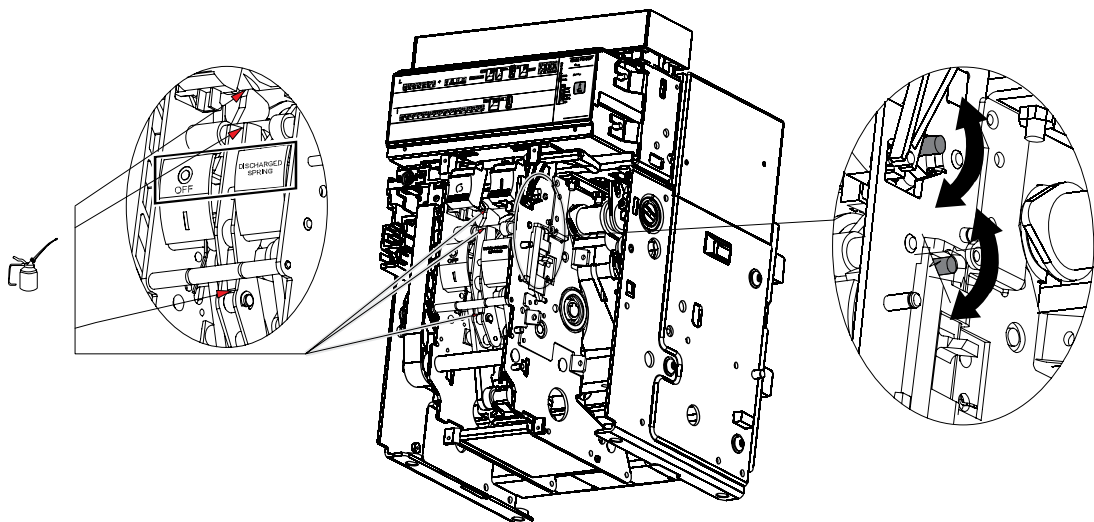

Fig. 35

Model	B2342	B2410		Apparatus	<b>Emax</b>	Scale
				Doc. No	<b>1SDH000460R0002</b>	Page No 21/74

### 8.3.6. Electrical and mechanical accessories

- Check that the accessories are fixed to the switch
- Check that the electrical accessories are connected to the switch
- Reduction gear: after 10000 operations check brushes for wear and replace the reduction gear if necessary.
- Check that the releases (SOR-UVR-SRC) are in good condition (no excessive wear, overheating, breakages) Fig. 36.
- Check that the mechanical operation counter is operating correctly (if applicable) by running an operation on the switch.

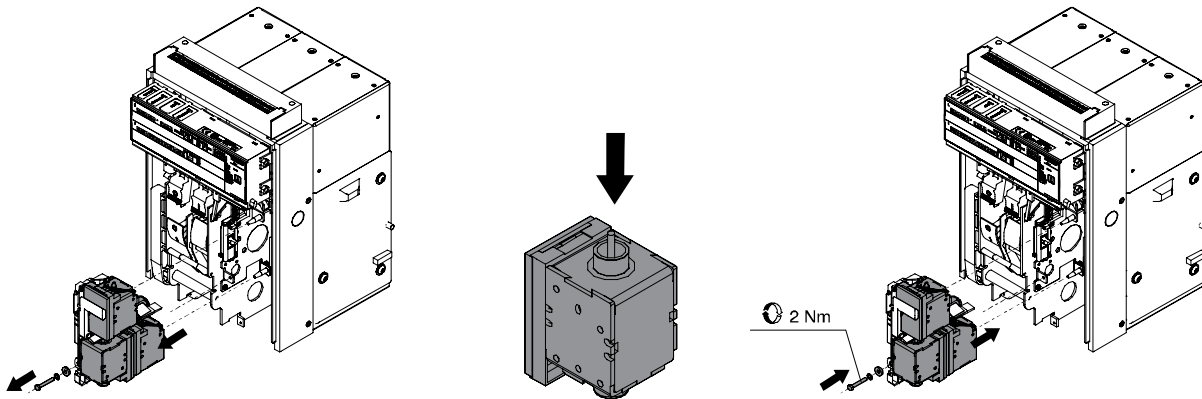

Fig. 36

### 8.3.7. Protection releases

- Supply the protection release from a PR030/B battery unit.
- Check that the protection release is working correctly: run "Trip Test" (PR121, PR122, PR123) and "Autotest" (PR122, PR123) for release.
- Use release PR122 or PR123 to check that there are no alarms on the display and via front LEDs.
- Use release PR121 to check that there are no alarms via front LEDs.
- Check that the cables are correctly connected to the release modules and to the release (if applicable).
- On PR122 and PR123 check the wear percentage to the switch contacts.
- At the end, remove the battery unit PR030/B from the relay.

Consult this manual for details about release PR121.

Consult manual 1SDH000460R0102 for details about releases PR122-PR123.

### 8.3.8. Test with SD Testbus2 (optional)

- Connect unit BT030 or BT030-USB to the relay to be tested.
- Run the programme SD.TestBus2 on a PC with a Bluetooth or USB connection, depending on the version of BT030 used.
- Once the connection between the relay and PC has been installed, check that there are no alarm signals from the relay; otherwise, consult the paragraphs 'Error Messages' and/or 'Troubleshooting' in this manual.
- In normal operating conditions the trip test and the autotest can be run (depending on the type of relay); for future checks, we advise inserting the current date in the User Data and/or Tag Name area. These data will be stored inside the relay.
- Remove the BT030 or BT030-USB from the relay.

Consult this manual for details about release PR121.

Consult manual 1SDH000460R0102 for details about releases PR122-PR123.

### 8.3.9. Maintenance operations; final checks

- Refit all parts and if necessary reconnect the auxiliary supply.
- Refit the cap as indicated in figure 37.

- Return the movable part to the TEST-ISOLATED position.
- Use the different auxiliaries in turn to run the following 10 operations:

- Opening (both local and remote as applicable)
- Closing (both local and remote as applicable)
- Release by trip test from the relay

- Check the operations according to this sequence:

- Open - Springs unloaded
- Open - Springs loaded
- Closed - Springs unloaded
- Closed - Springs loaded

- Check operation of the accessories, if present
- Check operation of reduction gear (if present)
- Check operation of minimum voltage release (if present)
- Check operation of opening release (if present)
- Check operation of closing release (if present)
- Check operation of auxiliary contacts of switch (if present)
- Check operation of lock of switch in open position (with key or padlocks) (if present)

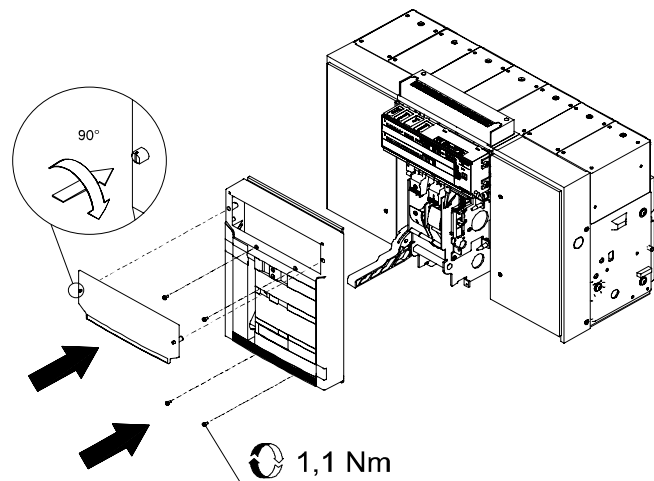

Fig. 37

Model	B2342	B2410		Apparatus	<b>Emax</b>	Scale
				Doc. no.	<b>1SDH000460R0002</b>	Page No <b>22/74</b>

### 8.3.10. Interlock

- Check that the interlock devices have been correctly installed and operate correctly between adjacent and superimposed switches (if present). The operating test cannot be run in the Test or Extracted positions.

### 8.4. Second level maintenance operations

#### 8.4.1. Preliminary operations:

- open the switch and check that the control springs are unloaded
- in the case of a circuit breaker, remove the circuit breaker from the fixed part before working on it



**WARNING:** before working on fixed switches or switches on fixed parts, disconnect the supply to the power circuit and to the auxiliary circuits and earth the terminals in a visible manner both on the supply and on the load side.

#### 8.4.2. General checks and cleaning:

- Check the cleanliness of the apparatus (switch part), removing dust and any traces of excess oil or grease with dry cloths (if necessary, use non-corrosive detergent)
- For excessive deposits, a laminated dilutant such as Henkel 273471 or the equivalent can be used.
- Check that the rating plates of the apparatus are in place
- Clean the rating plates with dry and clean cloths
- Eliminate any dust, mould, traces of condensation or oxidation also inside the fixed part of the apparatus if the switch is extractable
- Check that there are no factors such as overheating or cracks that may compromise switch insulation
- Check the circuit-breaking couple for damage (for the extractable switch, see feature A, fig 39).
- The couple must be silver in colour without trace of erosion or smoke
- Check that there are no foreign bodies in the switch cabinet
- Check that the fixing screws are tightened on the fixed side to the control panel (M8 - 25Nm).

#### 8.4.3. Connections between the switch and the control panel

- Use brushes and dry cloths to remove dust or dirt on the insulating parts (if necessary, use non-corrosive detergent - For excessive deposits, a laminated dilutant such as Henkel 273471 or the equivalent can be used).
- Check that there are no traces of overheating on the terminals. The problem is detected by discoloration of the parts in contact; the contact points are normally silver in colour.
- Check the tightness of the bolts fixing the connections to the terminals (M12 - 70Nm).



**WARNING:** Before working on fixed switches or switches on fixed parts, disconnect the supply to the power circuit and to the auxiliary circuits and earth the terminals in a visible manner both on the supply and on the load side.

- Check that the connecting screws of the cables of the terminal boards are tight (0.7 Nm).

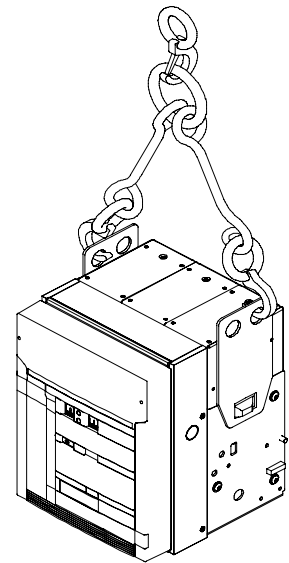

Fig. 38

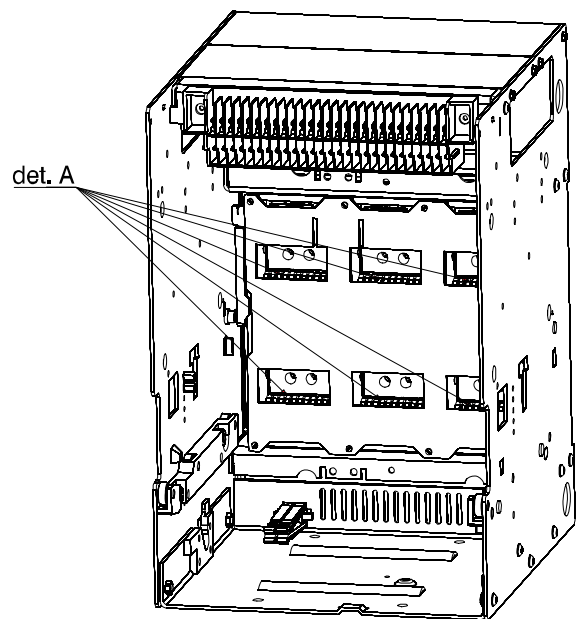

Fig. 39

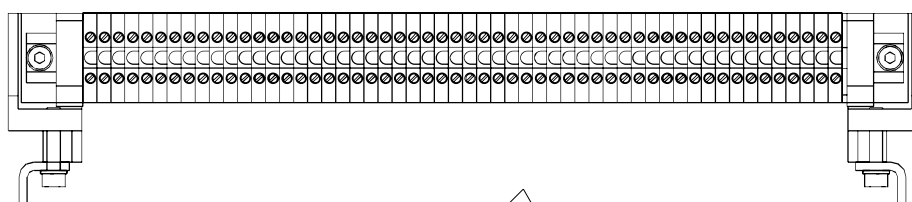

Fig. 40

Model	B2342	B2410		Apparatus	<b>Emax</b>	Scale
				Doc. No	<b>1SDH000460R0002</b>	Page No 23/74

#### 8.4.4. Dismantling the tab, cap and arcing chambers

- Remove the flange (1) of the release, turning the screws (2) as shown in the figures
- Remove the front escutcheon plate (3) by removing the four screws (4)
- Remove, if present, one or both side guards (5) by removing the front (6) and lateral (7) screws
- Remove the arcing chambers (8) by removing the screws (9).

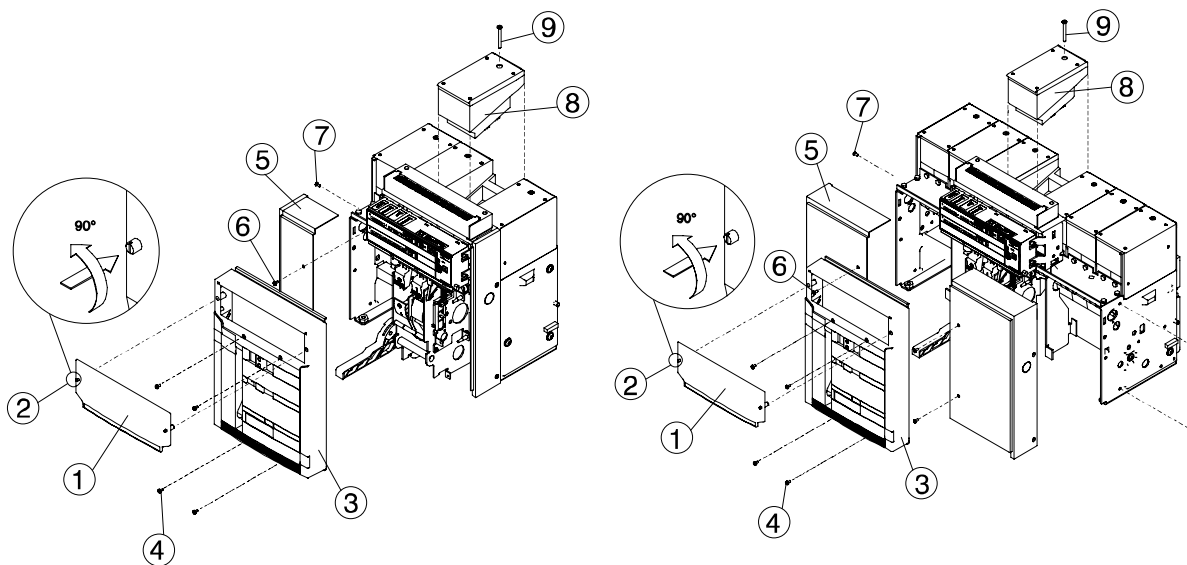

Fig. 41

- If there is a minimum release, dismantle the coil support and unload the control springs by opening and closing the switch.

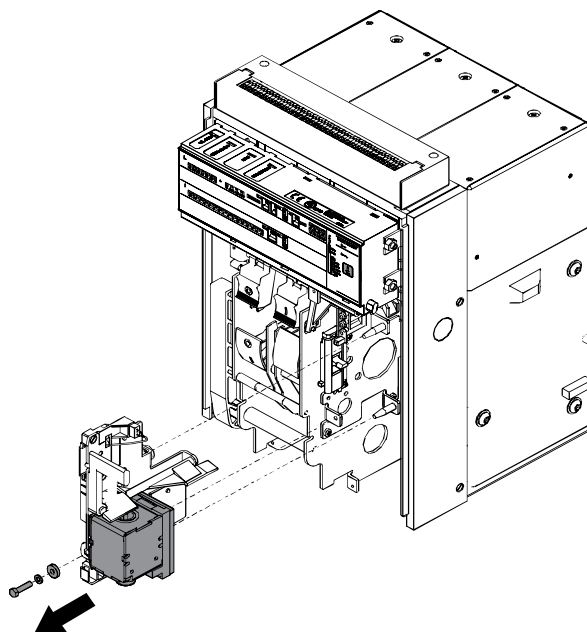

Fig. 42

Model	B2342	B2410		Apparatus	<b>Emax</b>	Scale
				Doc. no.	<b>1SDH000460R0002</b>	Page No <b>24/74</b>



#### 8.4.5. Mechanical control

- Cleaning (for excessive deposits, a laminated dilutant such as Henkel 273471 or the equivalent can be used) and lubricate, at the points indicated in fig. 43, part A, as for First Level, the opening and closing shafts and hooks with MOBILGREASE 28 (EXXON MOBIL).
- Cleaning (for excessive deposits, a laminated dilutant such as Henkel 273471 or the equivalent can be used) and lubricate with MOBILGREASE 28 (EXXON MOBIL) the supports of the operating shaft, including those on the sides of the switch (see fig. 43 part B).
- Check that the opening and closing shafts are free to rotate.

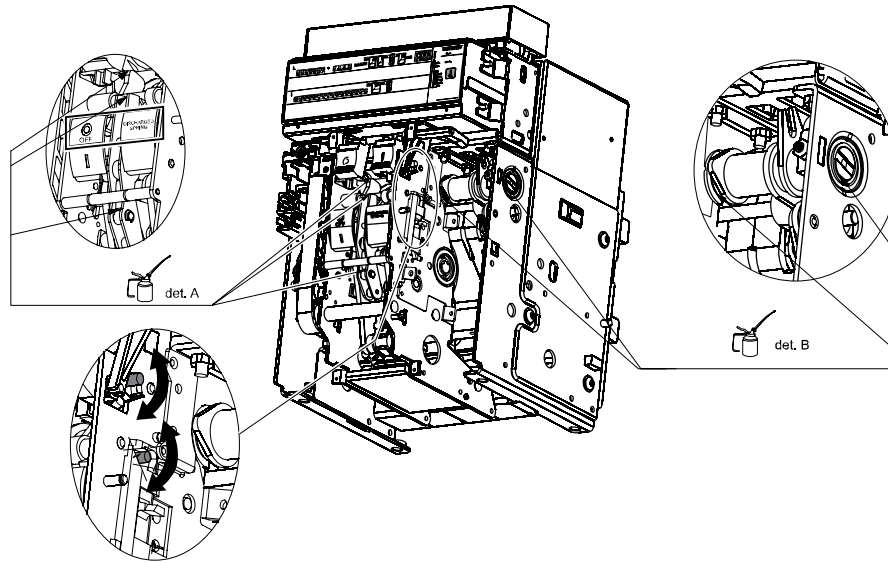

Fig. 43

- In the case of deformed or oxidated springs, missing rings or serious wear to the controls contact ABB Sace (\*).
- (\*) Subject to the customer's approval, ABB can replace "A" type parts.

#### 8.4.6. Electrical and mechanical accessories

- Check that the accessories are tightly fixed to the switch.
- Check that the electrical accessories are wired correctly to the switch.
- Reduction gear: after 10000 operations check brushes for wear and replace the reduction gear if necessary.
- Check that the releases (YO, YU, YC) are in good condition (no excessive wear, overheating, breakages) fig 44.
- Check that the mechanical operation counter is operating correctly (if applicable) by running an operation on the switch.

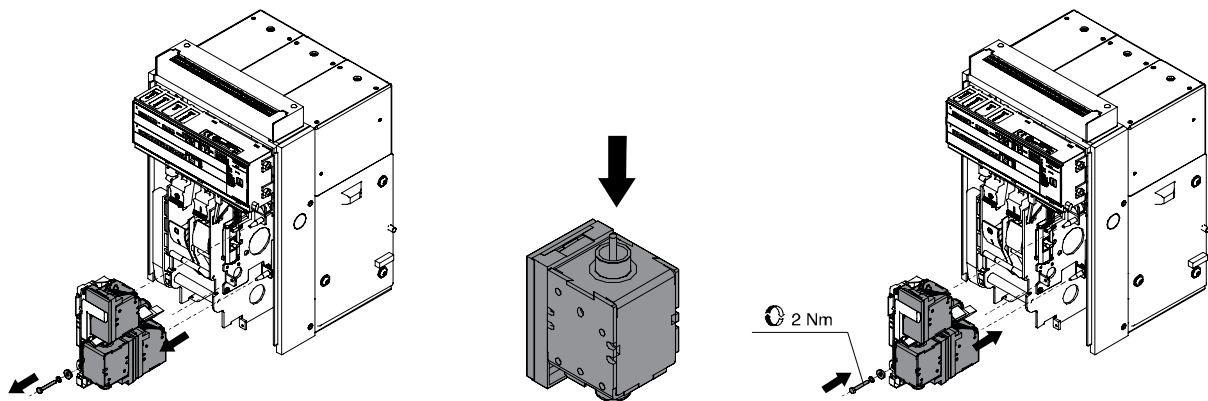

Fig. 44

#### 8.4.7. Checking contact wear

With the switch open and arcing chambers removed:

- 1) Check the state of the blowout magnet chambers: the body of the chamber must be undamaged and the plates must not be corroded or damaged.
- 2) Remove the dust with compressed air and remove traces of smoke and any waste with a brush of appropriate type.
- 3) Check the state of the contacts.
- 4) Visually check that the main plates and the blowout magnets are in place.
- 5) Check for oxidation or beads and if they are detected, request help from the qualified ABB technician (\*).

Model	B2342	B2410		Apparatus	<b>Emax</b>	Scale
				Doc. No	<b>1SDH000460R0002</b>	Page No 25/74

6.1) Check the blowout magnets distances (distance A fig 45).

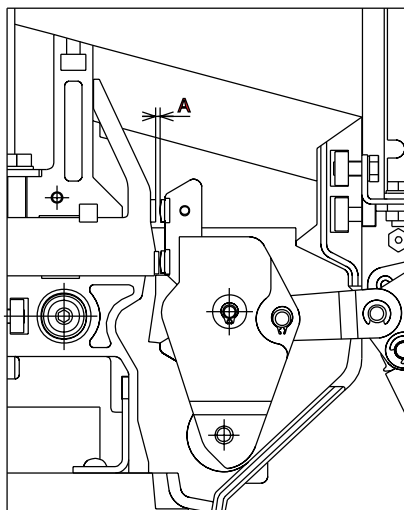

Circuit Breaker	A
E1 - E2 - E3	$\geq 1\text{mm}$ -->OK
E4 - E6	$\geq 0,8\text{mm}$ -->OK

Fig. 45

6.2) close the circuit-breaker and check the gap A

- If the gap A is not correct, contact ABB Sace (\*)
- If the gap A is correct, open the circuit breaker and refit the arc chambers.

(\*) Subject to the customer's approval, ABB can replace "A" type parts.

#### 8.4.8. Protection releases

- Supply the protection release with a PR030/B battery unit.
- Check operation of the protection release: release test with "Trip Test" (PR121, PR122, PR123) and "Autotest" (PR122, PR123).
- Use release PR122 or PR123 to check for the absence of alarms on the display and via front LEDs.
- Use release PR121 to check that there are no alarm signals via front LEDs.
- Check correct wiring of the cables to the modules of the release and to the release (if applicable).
- On PR122 and PR123 check the percentage of wear to the contacts of the switch.
- At the end, remove the battery unit PR030/B from the relay.

Consult this manual for details about release PR121.

Consult manual 1SDH000460R0011 for details about releases PR122-PR123.

#### 8.4.9. Test with SD Testbus2 (optional)

- Connect unit BT030 or BT030-USB to the relay to be tested.
- Run the programme SD.TestBus2 on a PC with a Bluetooth or USB connection, depending on the version of BT030 used.
- Once the relays and the PC have been connected, check that there are no alarm signals from the relay. If there are alarm signals, consult the paragraphs 'Error Messages' and/or 'Troubleshooting' in this manual
- In normal operating conditions, the trip test and the autotest can be run (depending on the type of relay),
- For future checks, we advise inserting the current date in the User Data and/or Tag Name area.
- Remove the BT030 or BT030-USB from the relay.

Consult this manual for details about release PR121.

Consult manual 1SDH000460R0102 for details about releases PR122-PR123.

Model	B2342	B2410		Apparatus	<b>Emax</b>	Scale
				Doc. no.	<b>1SDH000460R0002</b>	Page No <b>26/74</b>

#### 8.4.10. Maintenance operations; final checks:

- Refit each part and if necessary reconnect the auxiliary supply.
- Refit the cap as indicated in figure 46.

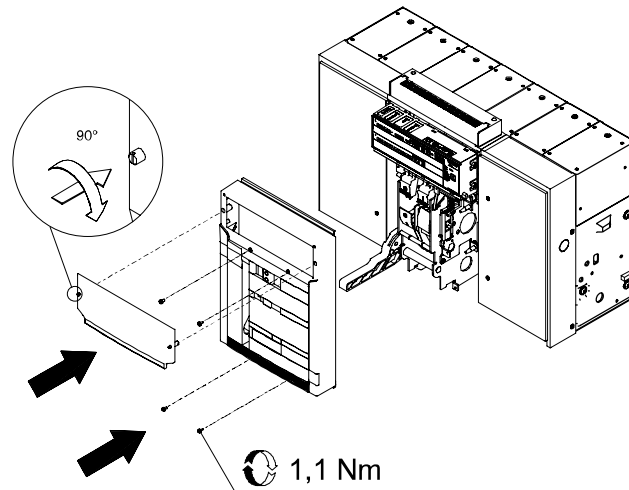

Fig. 46

- Return the movable part to the position TEST-ISOLATED.
- Use the different auxiliaries in turn to run the following 10 operations:
  - opening (both local and remote as applicable)
  - closing (both local and remote as applicable)
  - release by trip test from the relay
- Check the operations according to this sequence:
  - Open - Springs unloaded
  - Open - Springs loaded
  - Closed - Springs unloaded
  - Closed - Springs loaded
- Check operation of the accessories, if present
- Check operation of reduction gear (if present)
- Check operation of minimum voltage release (if present)
- Check operation of opening release (if present)
- Check operation of closing release (if present)
- Check operation of auxiliary contacts of switch (if present)
- Check operation of lock of switch in open position (with key or padlocks) (if present)

#### 8.4.11. Interlock

Check that the interlock devices have been correctly installed and operate correctly between adjacent and superimposed switches (if present). The operating test cannot be run in the Test or Extracted positions.

#### 8.4.12. Extractable

In the extractable versions, check the operational efficiency of the insertion and extraction of the switch from the fixed part, performing the movement by means of the operating lever supplied and checking that the shutters for segregating the parts carrying live voltage are closed after extraction. Check correct operation of the inserted and extracted switch lock devices (if present).

Model	B2342	B2410		Apparatus	<b>Emax</b>	Scale
				Doc. No	<b>1SDH000460R0002</b>	Page No <b>27/74</b>

### 9. Measures to be taken for any operating anomalies

The switch does not open when the opening button is pressed								<b>Anomalies</b>		
The switch does not open when the YO operating release is tripped										
The switch does not open when the YU minimum voltage release is tripped										
The switch does not open when the protection relay release test is run										
The switch does not shut when the close button is pressed										
The switch does not shut when the YC closing coil is tripped										
The closing springs cannot be loaded by the manual loading lever										
The closing springs cannot be loaded by the spring loading motor										
The crank does not fit in the moving part										
The moving part does not rack into the fixed part										
The switch cannot be locked in the open position										
								<b>Possible causes</b>	<b>Checks and remedies</b>	
								•	The opening solenoid of the relay is not inserted correctly	Check that opening solenoid is connected correctly
								• • •	Warning that tripped relay has not been reset	Press the mechanical pushbutton to reset signal relay tripped
								•	Auxiliary circuit power supply voltage too low	Measure the voltage: it must not be less than 85% of the rated nominal coil voltage
								•	Different power supply voltage from the one indicated on the rating plate of the releases	Check the rating plate voltage of the releases
								•	Operating circuit faulty	Check connections, fuses, interlocks, protection circuit-breakers and consent contacts
								• • •	Screws for clamping loose wires and auxiliary circuits	Check tightness of the screws connecting the wires
								•	Incorrect electrical connections in the power supply circuit	Check the connections with the corresponding circuit diagram
								•	Damaged coil	Replace the coil
								•	Operating mechanism blocked	Operate by hand. If the fault persists please contact ABB SACE
								• •	Key locked in open position	Unlock by inserting the key
								• •	Circuit-breaker in intermediate position between connected and test	Complete the insertion operation
								• •	Undervoltage release not energized	Check the corresponding power supply circuit and the power supply voltage
								• •	Shunt opening release permanently energized	Check the power supply circuit
								•	Racking-in or out operation not carried out correctly	See paragraph 7.3
								• • •	Locked control	Contact ABB SACE
								• •	Extraction crank inserted	Extract crank
								•	Switch in extracted position	Turn switch to test or inserted position
								•	Protection fuse tripped, spring-loading motor	Replace fuse
								•	Reduction gear fault due to automatic loading of springs	Replace reduction gear
								•	Movable part incompatible with the fixed part	Check that the movable part is compatible with the fixed part
								• •	Switch closed	Press the opening button and activate the lock
								•	Faulty open lock	Contact ABB SACE

 **WARNING:** Is lit and circuit-breaker's misoperation or nonoperation in your application could cause bodily injury, property damage or is otherwise critical, remove the circuit-breaker immediately until it can be inspected or repaired.

Model	B2342	B2410		Apparatus	<b>Emax</b>	Scale
				Doc. no.	<b>1SDH000460R0002</b>	Page No 28/74

## 10. Accessories

### 10.1. Electrical accessories

#### Shunt opening/closing (YO/YC) and second shunt opening release (YO2)

This allows remote opening or closing control of the apparatus. Given the characteristics of the circuit-breaker operating mechanism, opening (with the circuit-breaker closed) is always possible, whereas closing is only possible when the closing springs are loaded. Most of the releases can operate with either direct or alternating current. This release carries out an instantaneous service (\*), but can be supplied permanently (\*\*).

In uses where the shunt closing release is supplied permanently, to carry out the circuit-breaker reclosing operation after opening, it is necessary to momentarily de-energize the shunt closing release (the circuit-breaker operating mechanism reclosing is, in fact, fitted with an antipumping device).

In some versions it is necessary to have a very high degree of safety for the remote opening control of the circuit-breaker, and, in particular, the duplication of the control circuit of the shunt opening release is required. In order to achieve this, you can fit the SACE Emax circuit-breakers with a second shunt opening release. The second shunt opening release is located in the same seat as the undervoltage release and its technical characteristics are the same as the standard shunt opening release

(\*) In the case of instantaneous service, the minimum duration of the current impulse must be 100 ms.

(\*\*) In the case of permanent power supply to the shunt opening release, you must wait for at least 30 ms before giving the opening control to the shunt closing release.

Reference figures in the electrical circuit diagrams: YO (4) - YC (2) - YO2 (8)

Power supply (Un)	24 V DC	Operating limits (CEI EN 60947-2 Standards)	(YO-YO2) : 70...110% Un	
	30 V AC/DC		(YC) : 85...110% Un	
	48 V AC/DC		Inrush power consumption (Ps)	DC = 200 W
	60 V AC/DC		Inrush power time ~100 ms	AC = 200 VA
	110-120 V AC/DC		Continuous power (Pc)	DC = 5 W
	120-127 V AC/DC			AC = 5 VA
	220-240 V AC/DC		Opening time (YO - YO2)	(max) 60 ms
	240-250 V AC/DC		Closing time (YC)	60 ms ± 10 ms
	380-400 V AC		Insulation voltage	2500V 50 Hz (for 1 min.)
	440 V AC			

#### Undervoltage release (YU)

The undervoltage release opens the circuit-breaker in the case of a considerable drop or lack of its power supply voltage. It can be used for remote tripping (by means of normally closed type pushbuttons), as a lock on closing or to control the voltage in the primary and secondary circuits. The release power supply is therefore branched on the supply side of the circuit-breaker or from an independent source. Circuit-breaker closing is only allowed with the release powered (the closing lock is carried out mechanically). Most releases can operate with either direct or alternating current.

Power supply (Un)	24 V DC
	30 V AC/DC
	48 V AC/DC
	60 V AC/DC
	110-120 V AC/DC
	120-127 V AC/DC
	220-240 V AC/DC
	240-250 V AC/DC
	380-400 V AC
	440 V AC

Circuit-breaker opening takes place with power supply voltage values of the release equivalent to 35 - 70% Un.

Circuit-breaker closing is possible with power supply voltage of the release equivalent to 85-110% Un.

it can be fitted with a signalling contact for undervoltage release energized (C. aux YU)..

Reference figures in the electrical circuit diagrams: YU (6)

Inrush power consumption (Ps):	DC = 200 W
	AC = 200 VA
Continuous power (Pc):	DC = 5 W
	AC = 5 VA
Opening time (YU):	≤ 80 ms
Insulation voltage	2500V 50 Hz (per 1 min.)

Model	B2342	B2410		Apparatus	<b>Emax</b>	Scale
				Doc. No	<b>1SDH000460R0002</b>	Page No <b>29/74</b>

### Time delay device for undervoltage release (D)

The undervoltage release can be combined with an electronic time-delay device for installing outside the circuit-breaker, which enables a delay in the tripping of the release with preset, adjustable times. The use of the delayed undervoltage release is recommended when the power supply network of the release can be subject to power cuts or short-lived voltage drops, in order to avoid trips.

When it is not supplied, circuit-breaker closing is prevented.

The time-delay device has to be combined with an undervoltage release with the same voltage as the time-delay device.

Reference figures in the electrical circuit diagrams: YU + D; (7).

The characteristics of the time-delay device are:

Power supply (D):	24-30 V AC/DC
	48 V AC/DC
	60 V AC/DC
	110-127 V AC/DC
	220-250 V AC/DC
Adjustable opening time (YU+D):	0,5-1-1,5-2-3 s

### Geared motor for automatic closing spring loading (M)

This automatically loads the circuit-breaker operating mechanism closing springs. After circuit-breaker closing, the geared motor immediately sees to reloading the closing springs.

When there is no power supply or during maintenance work, the closing springs can still be loaded manually (by means of the special lever on the operating mechanism).

Power supply	24-30 V AC/DC
	48-60 V AC/DC
	100-130 V AC/DC
	220-250 V AC/DC
Operation limits:	85...110% Un (Norme CEI EN 60947-2)
Inrush power consumption (Ps):	DC = 500 W
	AC = 500 VA
Rated power (Pn):	DC = 200 W
	AC = 200 VA
Inrush time	0,2 s
Loading time:	4-5 s
Insulation voltage	2500 V 50 Hz (per 1 min.)

It is always supplied with limit contacts and microswitch for signalling closing springs loaded.

Reference figure in the electrical circuit diagrams: M (1)

### Mechanical and electrical trip signalling for overcurrent releases

The following signals are available following tripping of the overcurrent release:

#### a) Mechanical trip signalling for overcurrent releases

This enables a visual signalling on the operating mechanism by pushing the trip pushbutton in when the circuit-breaker has been opened following tripping of an overcurrent release. The circuit-breaker can only be closed again by putting the pushbutton back into its normal position included in the standard configuration.

Reference figure in the electrical circuit diagrams: S51 (13).

#### b) Electrical and mechanical trip signalling for overcurrent releases

This enables a visual signalling on the operating mechanism (mechanical) and remotely (electrically by means of a changeover switch) of the circuit-breaker being opened following a trip of the overcurrent releases. To reset the circuit-breaker, it is necessary to reset the mechanical indicator pushbutton.

Reference figure in the electrical circuit diagrams: S51 (13).

#### c) Coil for resetting the mechanical release trip indicator

This enables a visual signalling on the operating mechanism (mechanical) and remotely (electrically by means of a changeover switch) of the circuit-breaker being opened following a trip of the overcurrent releases. With this accessory, you can reset the mechanical indicator with an electronic relay using a remote control and this enables the circuit-breaker to be reset.

Power supply:	24-30 V AC/DC
	220-240 V AC/DC
	110-130 V AC/DC

Reference figure in the electrical circuit diagrams: S51 (14)

Model	B2342	B2410		Apparatus	<b>Emax</b>	Scale
				Doc. no.	<b>1SDH000460R0002</b>	Page No <b>30/74</b>

### Auxiliary contacts

Auxiliary contacts installed on the circuit-breaker are available to enable an indication of the circuit-breaker's status. A special version of the auxiliary contacts is also available (gold plated contacts) for a rated voltage under 24 V (digital signal).

Un	In max	T	Un	In max	cosφ
125 V DC	0,3 A	10 ms	250 V AC	5 A	0,3
250 V DC	0,15 A	10 ms			

The versions available are:

#### a) Electrical signalling for circuit-breaker open/closed

It is possible to have electrical signalling of the circuit-breaker status (open/closed) 4, 10 or 15 auxiliary contacts.

The auxiliary contacts can have the following configurations:

- 4 break/make contacts for PR121 (2 normally open + 2 normally closed)
- 4 + 2 break/make contacts for PR122/ PR123 (2 normally open + 2 normally closed + 2 for the release)
- 10 break/make contacts for PR121 (5 normally open + 5 normally closed);
- 10 + 2 break/make contacts for PR122/ PR123 (5 normally open + 5 normally closed + 2 for the release)
- 15 supplementary break/make contacts which can be mounted outside the circuit-breaker

The basic configuration described above can be modified by the user to indicate normally open or normally closed by repositioning the faston connector on the microswitch. When 10 contacts for PR122/ PR123 are required, zone selectivity and the PR120/K module are not available.

Reference Fig. in the electrical circuit diagrams: Q/1÷10 (21-22)

#### b) Electrical signalling for circuit-breaker connected/test isolated/disconnected

In addition to mechanical signalling of the position of the circuit-breaker, it is possible to have electrical signalling by means of 5 or 10 auxiliary contacts which are installed on the fixed part.

Only available for circuit-breakers in withdrawable versions for installing on the fixed part.

The auxiliary contacts can have the following configurations:

- 5 contacts; group consisting of 2 connected signalling contacts, 2 disconnected signalling contacts and 1 test position signalling contact (main contacts isolated, but sliding contacts connected)
- 10 contacts; group consisting of 4 connected signalling contacts, 4 disconnected signalling contacts and 2 test position signalling contacts (main contacts isolated, but sliding contacts connected)

Reference figure in the electrical circuit diagrams: S75I (31-32) - S75T (31-32) - S75E (31-32)

#### c) Contact for signalling closing springs loaded

This consists of a microswitch which allows remote signalling of the state of the circuit-breaker operating mechanism closing springs. The contact is always supplied with the spring loading geared motor.

Reference figure in the electrical circuit diagrams: S33 M/2 - (11)

#### d) Contact for signalling undervoltage release energized (C.aux YU)

The undervoltage releases can be fitted with a contact (by choice, normally closed or open) for signalling undervoltage energized for remote signalling of the state of the undervoltage release.

Reference figure in the electrical circuit diagrams: (12)

### Transformers and operation counters

#### a) Current sensor for the neutral conductor outside the circuit-breaker

The sensor allows neutral protection by means of connection to the overcurrent release and is available only for three-pole circuit-breakers. It is supplied on request.

Reference figure in the electrical circuit diagrams: UI/N

#### b) Homopolar toroid for the power supply earthing conductor (star center of the transformer)

PR122 and PR123 microprocessor-based electronic releases may be used in combination with an external toroid located on the conductor, which connects the star center of the MV/LV transformer (homopolar transformer) to earth: in this case, the earth protection is defined as Source Ground Return.

The In of the toroid can be regulated to 100 A, 250 A, 400 A, 800 A by using different combinations of the connections.

Reference figure in the electrical circuit diagrams: UI/0.

#### c) Homopolar toroid for residual current protection

The toroid enables the residual current protection to be activated and can be combined with the PR122/P LSIRc, PR122/P LSIG releases (with PR120/V) and PR123/P. The accessory is for installation on the busbars and is available in different sizes: up to 3200A for three- and four-pole circuit-breakers, up to 4000A for three-pole circuit-breakers.

#### d) Mechanical operations counter

This is connected to the operating mechanism by means of a simple lever mechanism. It indicates the number of circuit-breaker mechanical operations. The indication is visible on the front of the circuit-breaker from the outside.

Model	B2342	B2410		Apparatus	<b>Emax</b>	Scale
				Doc. No	<b>1SDH000460R0002</b>	Page No <b>31/74</b>

## 10.2. Mechanical locks

### a-b) Lock in open position

Different mechanisms are available which enable the circuit-breaker to be locked in the open position.

These devices can be controlled by:

- a key (a): a special circular lock with different keys (for a single circuit-breaker) or with the same keys (for several circuit-breakers). In the latter case, up to four different key code numbers are available.
- padlocks (b): up to 3 padlocks (not supplied): Ø 4 mm..

### c) Circuit-breaker lock in connected - test isolated - disconnected position

This device can be controlled by a special circular lock with different keys (for a single circuit-breaker) or with the same keys (for several circuit-breakers available up to four different key code numbers) and by padlocks (up to 3 padlocks, not supplied - Ø 4 mm). Only available for circuit-breakers in withdrawable versions for installing on the moving part.

### d) Accessories for lock in test isolated - disconnected position

In addition to the circuit-breaker lock in the connected - test isolated - disconnected position, this allows locking only in the disconnected or test isolated positions. Only available for circuit-breakers in withdrawable versions for installing on the moving part.

### e) Accessories for shutter padlocks

They enable the shutters to be padlocked (installed on the fixed part) in the closed position. Only available for circuit-breakers in withdrawable versions for installing on the fixed part.

### f) Mechanical lock on compartment door

This prevents the compartment door from being opened when the circuit-breaker is closed (and connected in the case of withdrawable circuit-breakers) and prevents circuit-breaker closing with the compartment door open.

## Transparent protection covers

### a) Protection covers for opening and closing pushbuttons

These protection covers, applied over the opening and closing pushbuttons, prevent the corresponding circuit-breaker operations except by using a special tool.

### b) IP54 door protection

This is provided by means of a transparent plastic escutcheon plate which fully protects the front of the circuit-breaker and ensures a degree of protection to IP54. Mounted on hinges, it is fitted with a key lock.

## Interlock between circuit-breakers

This mechanism makes the mechanical interlock between two or three circuit-breakers (even of different sizes and in any fixed/withdrawable version) by means of a flexible cable. The electrical circuit diagram for the electrical changeover by means of a relay (to be provided by the customer) is supplied with the mechanical interlock. The circuit-breakers can be installed vertically or horizontally.

4 types of interlocks are available:

- type A: between 2 circuit-breakers (power supply + emergency)
- type B: between 3 circuit-breakers (2 power supplies + emergency)
- type C: between 3 circuit-breakers (2 power supplies + bus-tie)
- type D: between 3 circuit-breakers (3 power supplies / a single closed circuit-breaker)

The emergency power supply is generally supplied in order to substitute the normal power supply in two cases:

- to supply safety services for people.
- to supply essential parts of the installation for other than the safety services.

The change over from the normal supply to the emergency supply, can be done manually (with a local or remote control) or automatically. For the change over, the circuit-breakers must be supplied with the necessary accessories for the electrical remote control and for electrical and mechanical interlocks provided for the changing over.

The accessories can be for example:

- the shunt opening release
- the shunt closing release
- the motor operator
- the auxiliary contacts

Model	B2342	B2410		Apparatus	<b>Emax</b>	Scale
				Doc. no.	<b>1SDH000460R0002</b>	Page No <b>32/74</b>



For the change over, the customer can use a suitable electronic relay, whose diagram is supplied by ABB SACE. The mechanical interlocks between two or three circuit-breakers are made by means of cables that can be used for circuit-breakers installed, either side-by-side or one over the other.

**Table of feasible mechanical interlocks between two or three circuit-breakers**

Type of interlock	Number of circuit-breakers	Type of circuit-breaker	Possible interlocks
A	TWO	A normal power supply unit and an emergency unit.	The first circuit-breaker can be closed only if the second (emergency) breaker is open.
B	THREE	Two normal power supply units and an emergency unit.	The first and third circuit-breakers can be closed only if the second (emergency) breaker is open. The latter can be closed only if the first and third are open.
C	THREE	A unit of 2 supplies and a bus-tie. The two half-busbars can be supplied by a single transformer (bus-tie closed) or simultaneously by both (bus-tie open).	One or two circuit-breakers out of three can be closed at the same time.
D	THREE	A unit of 3 supplies / a single closed circuit-breaker. Three supplies (generators or transformers) on the same busbar for which parallel operation is not allowed.	Only one of the three circuit-breakers can be closed.

### 10.3. Notes for Emax LTT Low Temperature accessories

The SACE Emax VF LTT, circuit breaker designed for low temperature environment, is accessoriable only with the standard opening, closing and undervoltage releases at 220V AC/DC.

The geared motor for the automatic charging of the spring is available with a special version for low temperature at 220V AC/DC. Mechanical and electrical signalling for overcurrent releases accessories, auxiliary contacts, terminals and fixed parts are in common to the Emax VF product.

Transparent pushbuttons protection covers, IP54 door protection, interlocks, homopolar toroid, time delay device for undervoltage release and external neutral current sensors are not available <sup>(1)</sup>.

(1) Consult ABB SACE

### 10.4. Spare parts and retrofitting

#### Spare parts

The spare parts available are:

- Complete single pole (\*) (Type "A")
- Arcing chamber
- Stored energy operating mechanism (\*) (Type "A")
- Closing springs kit (\*) (Type "A")
- Current sensors and release connecting cables
- Contact kits for clamp disconnection for a fixed part of the removable circuit breaker
- Creeping earth contacts (for withdrawable version)
- Frontal shield kit complete with caps and side shields
- Safety shutters fixed part shutters
- Transparent protection for PR121, PR122 and PR123 releases
- Opening solenoid for maximum current release PR121 / PR122 / PR123
- Testing front connecting cap for relay
- SACE PR030/B power supply unit
- Lubricating grease for stored energy operating mechanism
- Terminal board for fixed
- Creeping contacts, fixed part
- Creeping contacts, movable part
- Dust tab for door of cell
- Extraction crank
- Lifting plates pair
- Front escutcheon plate for Ronis-type key lock

**For further details, ask for the ABB SACE spare parts catalogue.**

(\*) Subject to the customer's approval, ABB can replace "A" type parts.

#### Retrofitting kits

The kits enable SACE Otomax and Novomax G30 circuit-breakers to be replaced, coupling the new circuit-breaker in the old switchboard.

Model	B2342	B2410		Apparatus	<b>Emax</b>	Scale
				Doc. No	<b>1SDH000460R0002</b>	Page No <b>33/74</b>

## 11. Protection releases - General notes

The ABB SACE Emax series of air circuit-breakers can be equipped with electronic relay PR121/P.

The available accessories and functions are listed in the table below.

Function/Unit	PR121
<b>Current protections</b> (L, S, I, G)	<b>S</b>
<b>Thermal memory</b>	<b>S</b>
<b>Local bus for external accessory units</b>	<b>S</b>
<b>Front connector for test unit and temporary power supply</b>	<b>S</b>
<b>Compatibility with Ekip Connect</b>	<b>S</b>
<b>HMI030</b> (Display via switchgear for ABB SACE relay)	<b>O</b>
Flex Interface (External signalling unit)	<b>O</b>
<b>PR030/B</b> (External power supply unit)	<b>T</b>
<b>BT030-USB</b> (External Bluetooth and USB powering and communication unit)	<b>T</b>
Ekip T&P (External unit for power supply, communication and testing via USB)	<b>T</b>
PR010/T (External unit for tests)	<b>T</b>

### Key:

- S** : standard function/unit
- O** : optional fixed unit
- T** : optional unit for temporary connection.

The main characteristics of relay PR121 are:

1. Highly accurate current reading (up to 1.5%).
2. Continuous control of the connection of the current sensors and trip coil.
3. Recording of the cause for tripping, also in the self-supply condition.
4. Extended neutral selection.
5. Connection to a PC via wireless Bluetooth (with BT030-USB) or USB (with BT030-USB or Ekip T&P).
6. Serial connection for external modules HMI030 and Flex Interface.
7. "Real time" date and time (adjustable with BT030-USB or Ekip T&P).
8. Software applications available for relay maintenance and tests.

### 11.1. Safety notes

 **WARNING: this symbol gives information about operations, actions or circumstances that can cause injuries to the personnel, damage to the unit or economic losses.**

Read this manual carefully and completely.

The use of this device should be reserved for qualified and expert personnel only.

If in doubt, about its safe usage, the unit must be put out of service to prevent any accidental use.

#### You must assume that safe usage is impossible if:

1. the unit shows visible signs of damage.
2. the unit does not function (for example with autotest or with the trip test unit).
3. the unit has been damaged in transit.

 **WARNING: Prior to servicing and/or replacing, the circuit-breaker must be open. Also remember to disconnect all power supplies connected.**

#### 11.1.1. Notes for dielectric stiffness tests

 **WARNING: Dielectric stiffness tests on the releases, inputs and outputs, are not permitted.**

Model	B2342	B2410		Apparatus	<b>Emax</b>	Scale
				Doc. no.	<b>1SDH000460R0002</b>	Page No <b>34/74</b>

## 11.2. Abbreviations and notes

### 11.2.1. Abbreviations

Abbreviations	Meaning
YO	Opening coil
YC	Closing coil
CB	Circuit-Breaker (for example Emax)
CS	Current Sensor (current transformer)
Ekip Connect	Communication software for PC, for electronic devices installed in ABB SACE CB
Emax	Series of ABB SACE air circuit-breakers
HW	Hardware
i-Test	"i-Test" button on the front of relay
In	Rated current of the Rating Plug installed in the circuit-breaker
LTT	Low Temperature Technology. Special CB version for low temperatures (-40°C ... +70°C)
MT	Thermal memory
Relè	also called "protection unit" or "protection release"
RMS	Root mean square value
SW	Software
TC	Trip Coil (opening solenoid)
Trip	CB opening, generated by the release
i-Test	"i-Test" button on the front of relay
Vaux	Auxiliary power supply

Model	B2342	B2410		Apparatus	<b>Emax</b>	Scale
				Doc. No	<b>1SDH000460R0002</b>	Page No <b>35/74</b>

## 12. SACE PR121/P RELAY

### 12.1. IDENTIFICATION

The PR121/P units available, in accordance with the IEC Standards, with the various default and optional protections and modules, are illustrated in the figure below:

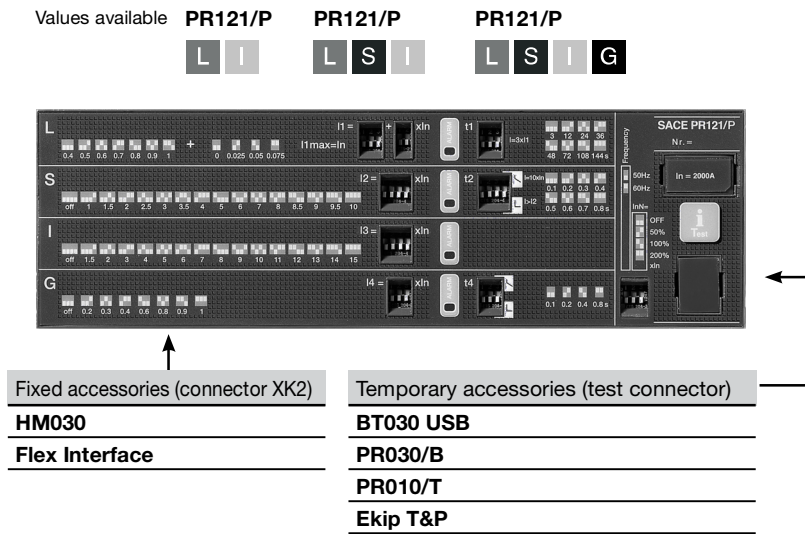

### 12.2. Specifications

#### 12.2.1. General characteristics

Relay PR121/P is an electronic unit for Emax CB. Its function is to monitor and protect against abnormal current.

The unit installed on the CB is connected to the current sensors for primary current reading and to the Trip Coil for circuit-breaker opening control.

The sensors provide the primary current measurement and the energy for powering the relay, even in the absence of external power supply.

Connected directly to an opening mechanism, the Trip Coil allows the CB to open. The control is transmitted to the Trip coil in accordance with the protection settings.

Dip switches on the front allow the main protections and settings to be regulated, while the state of the relay is indicated by the leds of the front interface.

Depending on the version, the protections available are as follows:

Symbol	Protection against
L	overload with inverse long time delay
S	short-circuit with adjustable delay
I	instantaneous short-circuit
G	earth fault with adjustable delay

The relay unit also provides a fixed protection against instantaneous short-circuit at high current values, called linst protection.

A set of accessories adds optional functions to the basic version.

Temporary accessories:

- PR030/B powers the relay so as to display its state (by means of the LEDs) and allow the installation operations to be performed.
- BT030-USB for relay powering and communication, so as to allow different sorts of information to be supervised via a PC, such as the Trip and measurements log file, and for regulating settings and functions that cannot be adjusted by means of the front dip switches, such as the Thermal Memory.

- PR010/T allows the relay to be supplied, enables the protections to be tested and test reports to be saved.

- Ekip T&P, similarly to BT030-USB, can be used to power and communicate with the relay via a PC. It also allows units like PR010/T to be tested, again via a PC.

Communication with ABB SACE devices is facilitated by the Ekip Connect SW supplied with BT030-USB and Ekip T&P modules, or available from the Internet website.

Fixed accessories:

- The HMI030 panel interface expands the monitoring functions of the relay and displays the current measurements of all the phases in real time.

- Flex Interface modules allow the alarm or state signals of the relay to be matched to programmable electromechanical contacts. They also allow a complete network of several units to be created and can also be connected to external modules (e.g. HMI030). Consult the following chapters or the dedicated manuals for details about each individual unit.

Model	B2342	B2410		Apparatus	<b>Emax</b>	Scale
				Doc. no.	<b>1SDH000460R0002</b>	Page No <b>36/74</b>

### 12.2.2. Compatibility CB

PR121/P can be installed on 3-pole CBs with and without an external neutral, or on 4-pole Emax CBs of any model.

The CB model establishes the rated uninterrupted current the circuit-breaker is able to support (I<sub>u</sub>).

The adjustable protections (L, S, I and G) refer to the I<sub>n</sub> model, defined by the interchangeable Rating plug module installed on the relay.

### 12.2.3. Standards

The PR121/P has been designed to work in accordance with the following international standard:

**IEC 60947-2 Low voltage apparatus. Circuit-breakers.**

### 12.2.4. Environmental characteristics

Operating temperature (Standard version)	-25 °C ... +70 °C
Operating temperature (LTT version for low temperatures)	-40 °C ... +70 °C
Storage temperature	-40 °C ... +70 °C
Relative humidity	0% ... 98% with condensation
Degree of protection (with PR121/P installed in the circuit-breaker)	IP 30

### 12.2.5. Electrical characteristics

#### 12.2.5.1. Primary current

Rated operating frequency	50/60 Hz ±10%
Peak factor	2,1 @ 2xI <sub>n</sub> in conformity to IEC 60947 Annex F (Consult ABB for a dedicated analysis if there are higher peak factors)

#### 12.2.5.2. Power supply

The relay unit needs a power source: this can be supplied by current sensors installed on the internal poles of the circuit-breaker or by means of an auxiliary source:

- All that's needed to supply the relay by means of internal current sensors is the presence of minimum three-phase turn-on current, as shown in the table below.
- Provided by a galvanically-separated power supplier, the external auxiliary power supply ensures continuous for the unit (even when there is no current flow, or in the open circuit-breaker condition) and adds to the accessory functions of the relay allowing HMI030 and Flex Interface external devices to be used.

To improve the supply condition, ABB recommends use of the auxiliary supply source when there are low load current values and/or distorted signals.

Primary current characteristics	Range	
	CB E1, E2, E3	CB E4, E6
Minimum three-phase busbar current	>100 A (*)	>200 A
Frequency, Peak factor	see par. 12.2.5.1	
Auxiliary power supply characteristics	Range	
DC voltage (galvanically separated)	24 Vdc ±20%	
Maximum ripple	5%	
Inrush current @ 24V	~10 A for 5ms	
Rated power @ 24V	~1 W	

NOTE:

(\*): Emax E1 and E2 I<sub>u</sub>=250A: minimum three-phase busbar current >30A.



**WARNING:** Since the auxiliary voltage needs to be isolated from the ground, "galvanically separated converters" in accordance with the IEC standard 60950 (UL 1950) or the equivalent IEC 60364-41 and CEI 64-8 have to be used to guarantee a current in common mode or leakage current (as defined in IEC 478/1 and CEI 22/3) no greater than 3.5 mA.

Model	B2342	B2410		Apparatus	<b>Emax</b>	Scale
				Doc. No	<b>1SDH000460R0002</b>	Page No 37/74

### 12.3. User interface

The graphic interface of relay PR121/P allows the protections and general state of the relay itself to be adjusted and displayed.

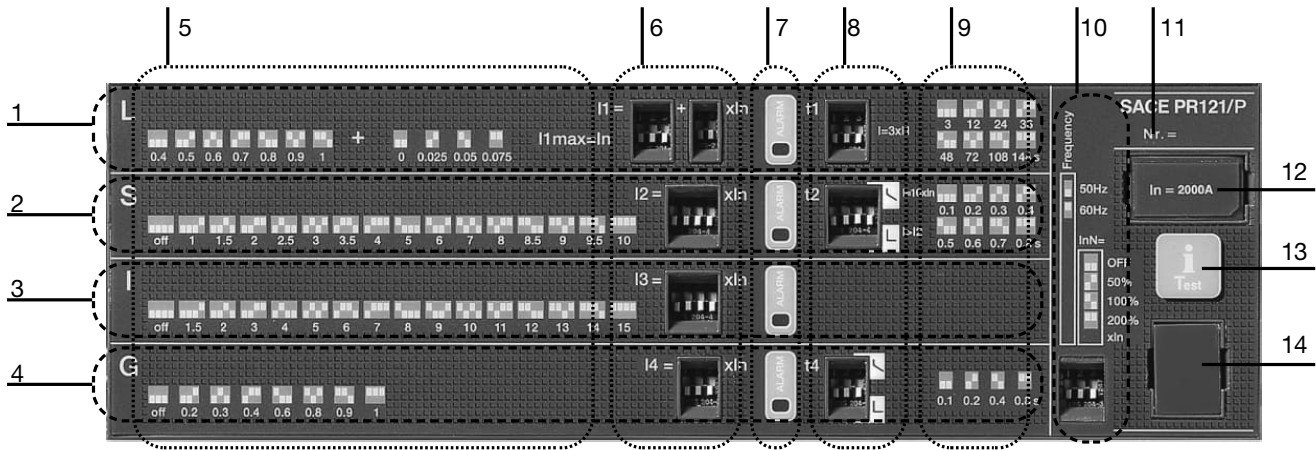

Rifer.	Description
1	Alarm indicator LED for protection function L
2	Section dedicated to protection S (not present for models PR121/P LI)
3	Alarm indicator LED for protection function I
4	Alarm indicator LED for protection function G (not present for models PR121/P LSI and PR121/P LI)
5	Dip switch position indications, with reference to the L, S, I, G protection thresholds
6	Dip switch for setting the thresholds of protections L (I1), S (I2), I (I3), G (I4)
7	LEDs for signalling Alarm state of protections L, S, I and G, Pre-alarm L, Power status indicator
8	Dip switch for setting the tripping times of protections L (t1), S (t2), G (t4)
9	Dip switch position indications, with reference to the thresholds of the tripping times L, S, G
10	Position indicator for the DIP switches for setting the neutral protection
11	Serial number of the relay
12	Rating plug
13	"i Test" test and info button
14	Test connector for external modules PR030/B, BT030-USB, Ekip T&P, PR010/T)

#### 12.3.1. Dip switches

The dip switches on the front of unit PR121/P are used for regulating the tripping thresholds of each protection and the tripping time. The available combinations are given alongside each group of dip switches.

**The dip switches for regulating the tripping times of protections S (t2) and G (t4) can also be used for selecting the tripping curve:**

- Fixed time tripping curve. The following relation is used:  $t=k$ .
- Inverse time tripping curve. The relation between the tripping time and over-current is given by the formula:  $t=k/I^2$

The dip switch settings can be changed when the relay unit is on and without alarms: updating is immediate. The unit need not be restarted.

**WARNING: The settings are inhibited if the relay is in the alarm condition (signalled by LEDs): settings changed by the user when the relay is in the alarm condition will not be recorded until the alarm condition ceases.**

An example of the dip switch setting for the protection L function, with 2000A Rating Plug ( $I_n = 2000A$ ) is given below.



$$I_1 = 0,4 + 0,025 \times I_n$$

$$I_1 = 850A$$

#### 12.3.2. LED

The following table shows how the LEDs are managed in accordance with the IEC standard 60073 (and clause 4.2.3.2 in particular).

Model	B2342	B2410		Apparatus	<b>Emax</b>	Scale
				Doc. no.	<b>1SDH000460R0002</b>	Page No <b>38/74</b>

There are 2 to 4 red leds for checking the state of the protections: the number of leds depends on the way the relay has been configured and on the protections installed.  
The led of protection L can also come on in the orange colour, thereby providing further information.

All the led combinations and the corresponding information are given in the table below.

Type of information	Flashing slowly (0,5Hz)	Flashing fast (2Hz)			LED flashing with two 0.5 sec pulses every 2 sec		LED flashing with one pulse every 3 sec	LED on permanently		
	All LEDs	All LEDs	Single LED		All LEDs	LED	LED	All LEDs	Single LED	
	RED	RED	RED	ORANGE	RED	ORANGE	ORANGE	RED	RED	ORANGE
TC: Error or disconnected		<input checked="" type="checkbox"/>								
CS: Error or disconnected	<input checked="" type="checkbox"/>									
Rating Plug: Error or Installation not performed					<input checked="" type="checkbox"/>					
Protection timing alarm <sup>(1)</sup> .			<input checked="" type="checkbox"/>							
Last trip <sup>(1)</sup>									<input checked="" type="checkbox"/>	
Test button pressed and no failure detected <sup>(2)</sup>								<input checked="" type="checkbox"/>		
Hardware Trip <sup>(3)</sup>									<input checked="" type="checkbox"/> <sup>(4)</sup>	<input checked="" type="checkbox"/>
L prealarm										<input checked="" type="checkbox"/>
Configuration error <sup>(5)</sup>				<input checked="" type="checkbox"/>						
Settings inconsistency						<input checked="" type="checkbox"/>				
Normal operation of the relay (Alive LED ON) <sup>(6)</sup>							<input checked="" type="checkbox"/>			

- (1) The led of the protection that has tripped or is being timed comes on to display the information. If it is the last trip, the led remains on for 2 sec or with fixed light if power source is external (from PR030/B).
- (2) The information is displayed with all the leds on for as long as the test button remains depressed, or for 2 seconds if it is pressed once.
- (3) If enabled, the hardware trip causes the CB to open within 1 sec. It activates in the case of “Cs Error” or “Rating plug Error”, or when the protection of Ne is “ON” in the 3P circuit-breaker without Ne ext (wiring error).  
The cause of tripping (CS Error, Rating Plug Error) is displayed in the presence of Vaux and/or PR030/B (connected during the event).  
The generic “Hw trip” signal remains in the absence of Vaux and/or PR030/B and is displayed by pressing the “I-test” key.
- (4) Orange L led and red I led on.
- (5) The values entered differ from those stored. Therefore, the relay must be installed (see par. 12.7).
- (6) In the absence of other information, correct operation of the unit is signalled 3 s after the unit itself has been powered. The “normal relay operation” signal can be disabled in units BT030-USB, Ekip T&P and PR010/T but in this case, the unit on signal (Alive LED OFF) will no longer be active.
- (7) see par. 12.4.1.
- (8) see par. 12.4.



**WARNING:** the leds only function when the relay is on: make sure that the minimum power supply conditions have been complied with in order to read the signals.

### 12.3.3. Rating Plug

The rating plug defines the rated current  $I_n$ , which is essential for regulating the protections. This is because the regulation of all the protections refers to  $I_n$  (e.g.:  $I_1 = 0.4 \cdot I_n$ ).  
The rating plug is installed on the relay on a dedicated front connector and is available to the user.

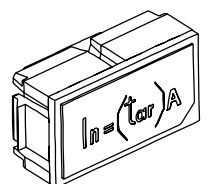

A relay can be equipped with various Rating Plug models, up to the value  $I_u$  (uninterrupted rated current  $I_u$  of the CB given on the rating plate of the front guard).  
Example: CB E1B800 has  $I_u = 800$  A, and can be fitted with a rating plug with  $I_n \leq 800$  A.

The module is interchangeable, with the relay off and the CB open.

The relay continuously checks for the presence of the rating plug and signals its absence or any assembly errors.



**WARNING:** Replacement of the rating plug with the relay on or the CB closed could lead to faulty relay operation or undesired opening of the CB.

### 12.3.4. iTest button

The itest button can be used for different functions:

Model	B2342	B2410		Apparatus	<b>Emax</b>	Scale
				Doc. No	<b>1SDH000460R0002</b>	Page No 39/74

- when the unit is off, it allows the last event recorded by the relay to be checked (when pressed for about 1 second). The function is available for 48 hours after the relay has been switched off (absence of internal or external power supply).
- with the unit powered by PR030/B alone and with the CB off, it allows the relay to be installed in the CB (see sect. 12.6).
- with the unit powered by PR030/B and the CB closed, it allows the LED test (when pressed for 3 seconds) and the trip coil operating mechanism (when pressed for 7 seconds) to be tested, with consequent opening of the CB.
- It allows the Trip signal to be reset (when pressed for about 1 second) after a tripping event, with the unit on.



**WARNING: in the case of operating temperatures between -40°C and -25°C, in versions where this is envisaged, the information only remains stored for 24 hours.**

### 12.3.5. Test connector

Installed at the front on the relay, the connector allows PR030/B modules to be connected for temporary power supply of the relay, and BT030-USB, PR010/T, Ekip T&P for powering, communication and testing via a PC (or via the unit itself in the case of PR010/T). Consult the chapters dedicated to the accessory modules for further details.

## 12.4. PROTECTION FUNCTIONS

Depending on the model, relay PR121/P handles up to 5 independent protection functions. Current signalling from the current sensors is processed by the microprocessor of the relay which, depending on the protection levels and time settings, gives alarms, accomplishes timing processes and sends commands.

All the adjustable protections process according to the true root mean square value of the current values read by means of the current sensors.

A time indication ("alarm" led) is available on the front of the unit and activates during an alarm for each protection. It deactivates when the alarm ceases or if the protection trips.



**WARNING:** when activated, the protections must guarantee the following rule:

$I_1(\text{protection L}) < I_2(\text{protection S})$  and  $I_2(\text{protection S}) < I_3(\text{protezione I})$ .

Incorrect protection settings lead to an error signal from the relay (inconsistent settings).

The unit is equipped with a "protection-backup" function. If the first command transmitted to the trip coil fails to open the circuit-breaker immediately (TC partially faulty) further commands are transmitted to the trip coil until the circuit-breaker opens.

### 12.4.1. Protection L

- Protection L is the only adjustable protection that cannot be disabled since it is for self-protection against overloading of the relay itself.
- - The type of curve setting is  $t=k/I^2$  and the tripping time is calculated according to the value of  $I_f \cdot t_1$ .
- - For fault currents  $I_f \leq 12I_n$ , the tripping time of the protection is given by the expression:  $t(s) = \frac{I_f \cdot t_1}{(I_f/I_1)^2}$ . If the calculated value is less than 1 second, the real tripping time is forced to 1 second ( $t(s) = 1s$ ).
- - For fault currents  $I_f > 12I_n$ , the tripping time is always  $t(s) = 1s$ .

#### NOTES:

- $t(s)$  = envisaged tripping time;
- $I_f$  = fault current; given in [In] (example: 0.7In)
- $I_1, t_1$  = protection L parameters set by the user, given in [In] and [s]

Protection L has 3 operation conditions established by the primary current level  $I_f$  and by the setting of the protection itself  $I_1$ :

$I_f \leq 0.9 \times I_1$	No alarm, all settings possible. No time setting in progress.
$0.9 \times I_1 < I_f < (1.05 \dots 1.2) \times I_1$	Prealarm L signal, all settings possible. No opening time setting in progress.
$(1.05 \dots 1.2) \times I_1 < I_f$	Alarm L signal, no setting possible. Opening time setting in progress.



**WARNING: the protection L threshold range ensures that:**

- the relay does not set to the alarm status for current values of less than  $1.05 \times I_1$ ;
- the relay will set to the alarm status for current values exceeding  $1.2 \times I_1$ .

#### 12.4.1.1. Thermal memory L

The thermal memory function can be enabled to protect the cables. It is based on the "τL" parameter defined as trip time of the curve ( $t_1$ ) selected @1.25xI1. This function can be enabled through PR010/T, or Ekip Connect. The trip time of the release surely is 100% of the time selected after a τL time has elapsed from the last overload or last trip, or else trip time will be reduced depending on the overload and time elapsed.

IPR121/P is equipped with two instruments to make up this thermal memory. The first one is only effective when the release is powered (it also records overloads that have not lasted long enough to trip the release); the second operates even when the release is not powered, reducing any trip times when it closes again straight after and is enabled as soon as the circuit-breaker is tripped. The PR121/P release determines which one to use according to the situation.

### 12.4.2. Protection S

The protection, which can be disabled, can be the fixed time ( $t=k$ ) or inverse time ( $t=k/I^2$ ) type.

The tripping time with inverse time curve is given by the expression:  $t(s) = \frac{100 \cdot t_2}{(I_f)^2}$ . If the calculated value is less than  $t_2$ , the

Model	B2342	B2410		Apparatus	<b>Emax</b>	Scale
				Doc. no.	<b>1SDH000460R0002</b>	Page No 40/74



real tripping time is forced to  $t_2$  ( $t(s) = t_2$ .)

NOTES:

- $t(s)$ = envisaged tripping time;
- $I_f$ = fault current; given in [In] (example: 1.7In)
- $I_2, t_2$ = protection S parameters set by the user, given in [In] and [s]

#### 12.4.2.1. Thermal memory S

The thermal memory function can be enabled for cable protection when the curve with inverse time is selected. This is based on the “tS” parameter defined as the trip time of the curve ( $t_2$ ) selected at  $1.5 \times I_2$ . The other characteristics are the same as those for thermal memory “L”.

#### 12.4.3. Protection I

This protection can be disabled; it is of the fixed time ( $t=k$ ) type, and is designed for a nil intentional delay.

#### 12.4.4. Protection G

The protection, which can be disabled, can be the fixed time ( $t=k$ ) or inverse time ( $t=k/I^2$ ) type.

The tripping time with inverse time curve is given by the expression:  $t(s) = \frac{2}{(I_f/I_4)^2}$ ; If the calculated value is less than  $t_4$ , the real tripping time is forced to  $t_4$  ( $t(s) = t_4$ ).

NOTES:

- $t(s)$ = envisaged tripping time;
- $I_f$ = fault current; given in [In] (example: 3.7In)
- $I_4, t_4$ = protection G parameters set by the user, given in [In] and [s]

The PR121/P unit can provide earth fault protection, achieved inside the relay by vectorially adding together the phase and neutral currents. The fault current is defined by the following formula:

$$\vec{I}_G = \vec{I}_1 + \vec{I}_2 + \vec{I}_3 + \vec{I}_N$$

If there is no fault in the circuit, the modulo-sum of these currents is always nil.

Vice versa, the fault current will acquire an increasingly higher value, depending on the entity of the fault.



**WARNING: protection G is disabled for current values exceeding 8In (for  $I_4 \geq 0,8In$ ), higher than 6In (for  $0,5In \leq I_4 < 0,8In$ ) and higher than 4In (for  $I_4 < 0,5In$ )**



**ATTENZIONE: With  $I_u \geq 800A$ : In the absence of Vaux and with  $I_4 < 100A$ , the SW forces the minimum threshold to 100A and LED show “Settings inconsistency” error. With  $I_u \geq 250A$ : In the absence of Vaux and with  $I_4 < 30A$ , the SW forces the minimum threshold to 30A and LED show “Settings inconsistency” error.**

#### 12.4.5. Neutral Protection

Unit PR121/P allows the current signal of the neutral pole to be processed with different ratios in relation to the phase values. The following values can be set for this protection:  $I_nN = \text{Off} - 50\% - 100\% - 200\% * I_n$ . The neutral protection is set by default at a current value equal to 50% of the phase regulation.

Regulation of the neutral value ( $I_nN$ ) must conform to the following formula:  $(I_1 \times I_nN) \leq I_u$ .

The relay performs the test automatically for four-pole circuit-breakers and transmits a fault signal following failure to conform to this formula. If the circuit-breaker is the three-pole type with external neutral, no tests will be performed by the relay and correction of the settings is at the user’s charge.

- E.g. With CB E1B800 ( $I_u = 800A$ ), Rating plug 400A ( $I_n = 400A$ ) and  $I_1 = 1I_n$ , the  $I_nN$  setting can be: 50-100-200%.  
 With CB E1B800 ( $I_u = 800A$ ), Rating plug 800A ( $I_n = 800A$ ) and  $I_1 = 1I_n$ , the  $I_nN$  can be: 50-100%.

The  $I_1 = 1I_n$  setting is the maximum setting of the protection against overload. The real permissible maximum setting must take account of derating due to the temperature, terminals used and the altitude.



**WARNING: In some installations, where particularly high harmonics occur, the current circulating on the neutral may be higher than that of the phases.**



**WARNING: For three-pole circuit-breakers without external neutral, the Neutral protection setting must be Off, otherwise the sensor presence error will be signalled (Error CS). In these cases, connect T5-T6 to the sliding contacts, as shown in the wiring diagrams.**



**WARNING: Failure to comply with the setting limits for “ $I_1$ ” and “ $I_nN$ ” can cause circuit-breaker damage with consequent risks even for the operator.**



**WARNING: the protection setting is automatically 100% when the current value exceeds  $15.5 \times I_n$  on the neutral.**

Model	B2342	B2410		Apparatus	<b>Emax</b>	Scale
				Doc. No	<b>1SDH000460R0002</b>	Page No <b>41/74</b>

**12.4.6. Protection against instantaneous short-circuit “Iinst”**

The purpose of this protection is to maintain the integrity of the circuit-breaker and installation in the case of particularly high current requiring shorter reaction times than those guaranteed by the instantaneous short-circuit protection. The protection cannot be disabled. It has a single fixed time protection curve and the threshold level is exclusively at the charge of ABB personnel.

**12.4.7. Summary table of protections**

Protection	Disabling	Trip threshold	Trip time	Trip threshold tolerance <sup>(2)</sup>	Trip time tolerance <sup>(2)</sup>
<b>L</b> ( $t=k/I^2$ )	<input type="checkbox"/>	<b>I1</b> = 0.4 - 0.425 - 0.45 - 0.475 - 0.5 - 0.525 - 0.55 - 0.575 - 0.6 - 0.625 - 0.65 - 0.675 - 0.7 - 0.725 - 0.75 - 0.775 - 0.8 - 0.825 - 0.85 - 0.875 - 0.9 - 0.925 - 0.975 - 1 x In	t1 3 - 12 - 24 - 36 - = 48 - 72 - 108 - 144 s <sup>(1)</sup> @I <sub>f</sub> =3I1	Release between 1.05 and 1.2 x I1	± 10% I <sub>f</sub> ≤ 6 x In ± 20% I <sub>f</sub> > 6 x In
<b>S</b> ( $t=k$ )	<input checked="" type="checkbox"/>	<b>I2</b> = 1 - 1.5 - 2 - 2.5 - 3 - 3.5 - 4 - 5 - 6 - 7 - 8 - 8.5 - 9 - 9.5 - 10 x In	Where I <sub>f</sub> > I2 t2 0.1 - 0.2 - 0.3 - 0.4 - = 0.5 - 0.6 - 0.7 - 0.8 s	± 7% I <sub>f</sub> ≤ 6 x In ± 10% I <sub>f</sub> > 6 x In	The best of the two data: ± 10% o ± 40 ms
<b>S</b> ( $t=k/I^2$ )	<input checked="" type="checkbox"/>	<b>I2</b> = 1 - 1.5 - 2 - 2.5 - 3 - 3.5 - 4 - 5 - 6 - 7 - 8 - 8.5 - 9 - 9.5 - 10 x In	t2 0.1 - 0.2 - 0.3 - 0.4 - = 0.5 - 0.6 - 0.7 - 0.8 s @ 10 In	± 7% I <sub>f</sub> ≤ 6 x In ± 10% I <sub>f</sub> > 6 x In	± 15% I <sub>f</sub> ≤ 6 x In ± 20% I <sub>f</sub> > 6 x In
<b>I</b> ( $t=k$ )	<input checked="" type="checkbox"/>	<b>I3</b> = 1,5 - 2 - 3 - 4 - 5 - 6 - 7 - 8 - 9 - 10 - 11 - 12 - 13 - 14 - 15 x In	≤ 30 ms	± 10%	
<b>G</b> ( $t=k$ )	<input checked="" type="checkbox"/>	<b>I4</b> = 0,2 - 0,3 - 0,4 - 0,6 - 0,8 - 0,9 - 1 x In	Where I <sub>f</sub> > I4 t4 0.1 - 0.2 - 0.4 - 0.8 s =	± 7%	The best of the two data: ± 10% o ± 40 ms
<b>G</b> ( $t=k/I^2$ )	<input checked="" type="checkbox"/>	<b>I4</b> = 0,2 - 0,3 - 0,4 - 0,6 - 0,8 - 0,9 - 1 x In	Minimum trip time t4 0.1 - 0.2 - 0.4 - 0.8 s =	± 7%	± 15%

(1)The minimum value of this trip is 1s regardless of the type of curve set (self-protection).

(2)These tolerances apply in the following conditions:

- Self-powered relay (no start-up) with 2 or 3 supplied phases and/or in presence of auxiliary supply. .
- operating temperature within the -25° ...70° range
- primary current values within the operating limits (see par. 12.2.5.1)

For all cases not covered by the above hypotheses, the following tolerances apply:

Protection	rip threshold	Trip time
<b>L</b>	Release between 1,05 e 1,25 x I1	± 20%
<b>S</b>	± 10%	± 20%
<b>I</b>	± 15%	≤ 60ms
<b>G</b>	± 10%	± 20%
<b>Others</b>	± 20%	

**12.4.8. Trip curves**

The trip curves provided are merely for guidance and only show a sub-group of the possible selections.

**12.4.8.1. Trip curves for functions L-I**

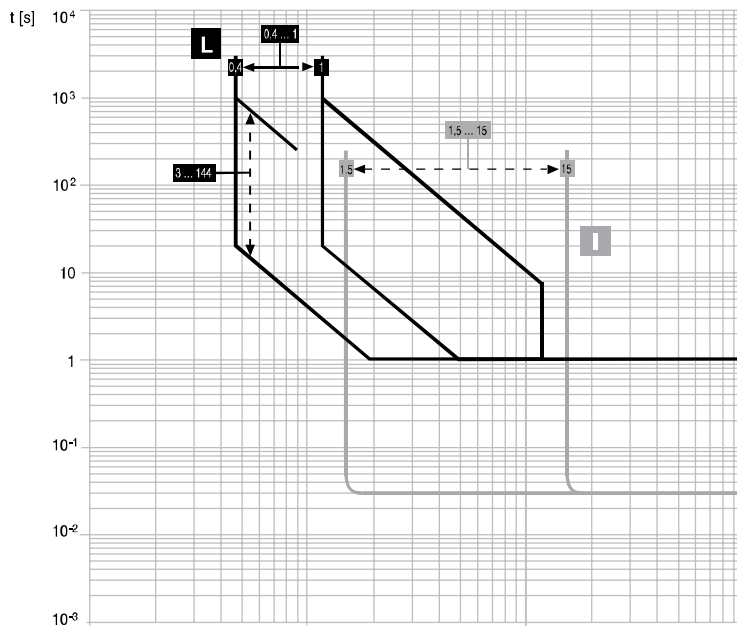

Model	B2342	B2410		Apparatus	<b>Emax</b>	Scale
				Doc. no.	<b>1SDH000460R0002</b>	Page No 42/74

12.4.8.2. Trip curves for functions L-S(t=k/I<sup>2</sup>)-I

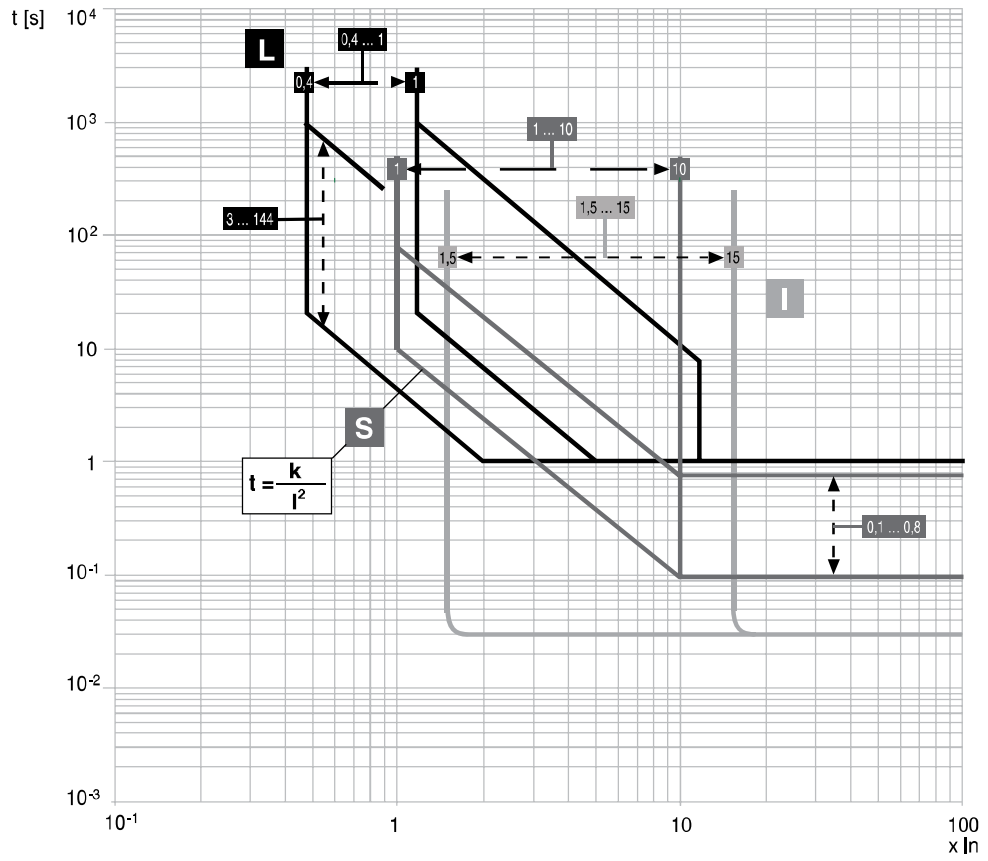

12.4.8.3. Trip curves for functions L-S(t=k)-I

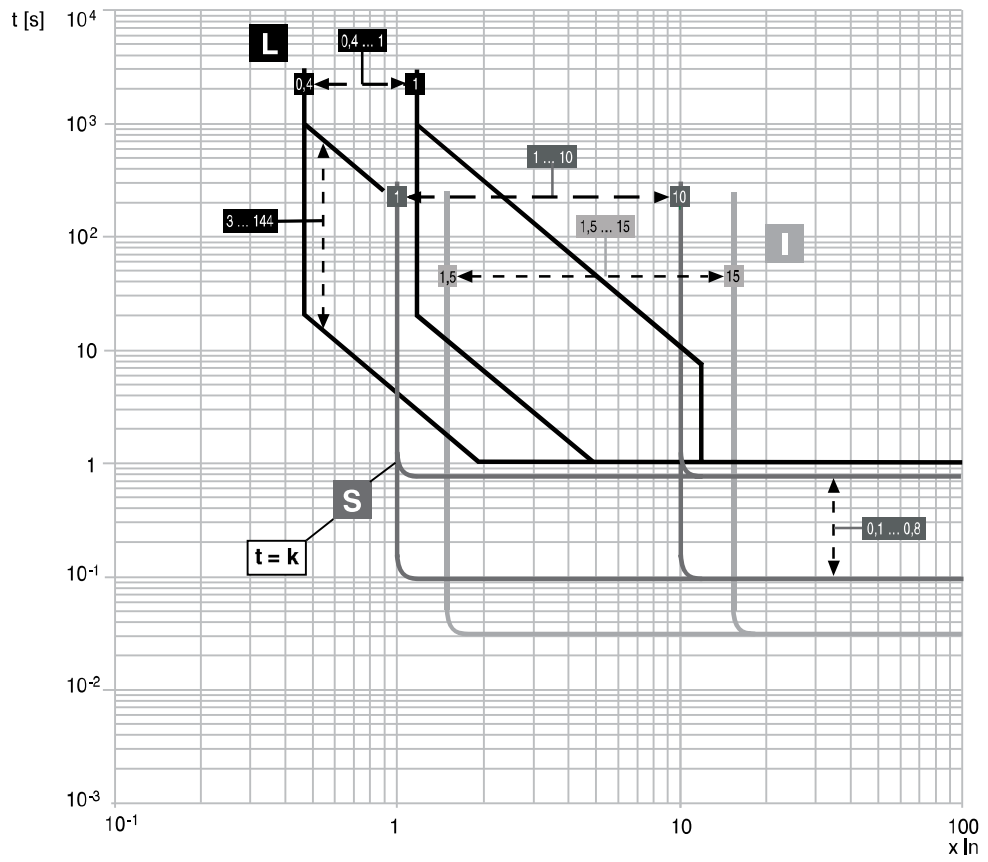

Model	B2342	B2410		Apparatus	<b>Emax</b>	Scale
				Doc. No	<b>1SDH000460R0002</b>	Page No 43/74

#### 12.4.8.4. Trip curves for function G

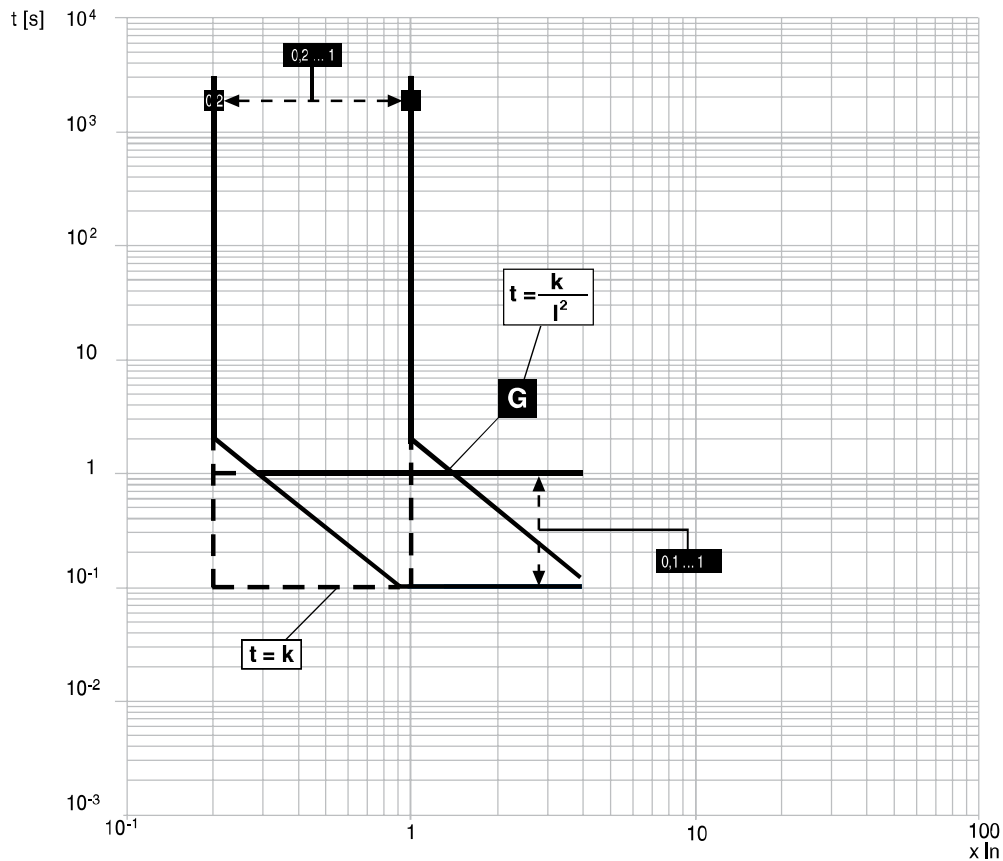

#### 12.5. Main functions

##### 12.5.1. Measurement

The current measuring (ammeter) function is available in all versions of the PR121/P unit. This function is accessible by means of test unit BT030-USB, Ekip T&P (connected to a PC) and PR010/T, or by means of HMI030. The measurement tolerance margins are:

Type of measurement	Range of values measured by the relay	Standard operation range	
		Range	Tolerance %
Phase and neutral current	0,05 ... 16 $I_n$	0,3 ... 6 $I_n$	$\pm 1,5$
Earth fault current	0,05 ... 4 $I_n$	0,3 ... 4 $I_n$	$\pm 1,5$

The relay allows the maximum current reading to be periodically recorded: this function must be enabled with test unit BT030-USB or Ekip T&P, and requires auxiliary voltage.

##### 12.5.2. Self-monitoring

The PR121/P unit provides certain self-monitoring functions that allow faults or setting errors to be identified more easily. Faults are signalled by a combination of led lights.

The functions are as follows:

- Rating Plug validity.
- Checks to find out whether the current sensors (CS) are connected correctly.
- Watchdog for proper connection of the Trip Coil (TC).
- Hw Trip protection. If activated, a CB opening command is transmitted through activation of the TC if sensors are disconnected or if the Rating Plug is not connected/faulty. This function can be activated by means of test unit PR010/T, BT030-USB or Ekip T&P.

Model	B2342	B2410		Apparatus	<b>Emax</b>	Scale
				Doc. no.	<b>1SDH000460R0002</b>	Page No 44/74

## 12.6. Putting into service and recommendations

### 12.6.1. Installation

Circuit-breakers purchased with the relay unit assembled do not require this operation which is, however, necessary in the case of replacement.

Comply with the following instructions to install a PR121/P:

1. With the circuit-breaker open and possibly isolated, install the protection unit on the circuit-breaker by connecting all the cables as shown in the assembly documents.
2. Power the unit with PR030/B only.
3. If there are no other errors apart from the configuration one, press the "i Test" button for a few seconds until all the red leds flash to confirm that installation has taken place.
4. Remove the PR030/B.
5. Power the relay from any other source (Vaux, PR030/B, PR010/T).
6. Make sure that there are no configuration errors (check that the LEDs are on in the Alive LED ON configuration).
7. The circuit-breaker and relay can now be put into service.



**WARNING: Consult ABB about the relay replacement and installation operations if the CB is the LTT version.**

### 12.6.2. Connections



**WARNING: Strict compliance with the instructions given in this document is required for the connections at the user's charge. This will ensure compliance with all the international reference standards and will ensure that the relay functions correctly even in heavy duty environmental and electromagnetic conditions. Pay particular attention to the earth connection.**

### 12.6.3. CS and TC connection check



**WARNING: If the PR121/P has been installed by the user, remember to check (with the CB open and Vaux or PR030/B), prior to putting the circuit-breaker into service, to make sure that the CS and TC cables have been connected correctly. Make the correct connections if this is not the case. If all the red leds come on, it means that there is an error in the CS and/or TC connections**

### 12.6.4. Connection of current sensor for external neutral



**WARNING: Remember to set the InN in the appropriate way if the current sensor for the external neutral conductor must be connected to a three-pole circuit-breaker. During this phase, the circuit-breaker must be open and, if possible, isolated.**

## 12.7. Parameter and default settings

Before the PR121/P is put into service, it is essential for the user to define and carefully adjust the editable parameters to suit his installation requirements.

ABB SACE will apply the adhesive rating plates of all the variables concerning the CB (e.g. Type of CB, Rating Plug size, etc.) so as to provide the user with all the information he needs to define the parameters.

The PR121/P is supplied by ABB SACE with the following preset parameters:

#	Protection	Threshold	Time
1	L	1 In	144 s
2	S	Off	0,1 s
3	I	4 In	--
4	G	Off	0,1 s
5	Mains frequency	50 Hz	
6	Neutral sel	*	

Note:

\* = Off for 3-pole versions

\* = 50% for 4-pole versions

\* = 100% for full-size versions

Model	B2342	B2410		Apparatus	<b>Emax</b>	Scale
				Doc. No	<b>1SDH000460R0002</b>	Page No <b>45/74</b>

## 12.8. Troubleshooting

### 12.8.1. Troubleshooting

The following table lists a series of typical service conditions, to help you understand and solve hypothetical faults or malfunctions.

**N.B.:**

1. Before consulting the following table, check for a few seconds for any optical signals provided by the LEDs.
2. FN indicates the normal operation of the PR121/P.
3. If the following suggestions fail to solve the problem, please contact the ABB SACE customer support service.
4. If possible, use the external communication units and supply a report downloaded by means of Ekip Connect.

N°	Situation	Possible causes	Suggestions
1	The trip test cannot be run	1. The busbar current is $i > 0$ 2. The TC is not connected 3. PR030/B is not connected	1. Normal operation (FN) 2. Check TC connection (see par. 12.6.3) 3. Connect the PR030/B unit
2	Trip times lower than expected	1. Threshold too low 2. Curve too low 3. Incorrect neutral selection	1. Correct threshold 2. Correct curve 3. Correct neutral adjustment
3	Trip times higher than expected	1. Threshold too high 2. Curve too high 3. Curve type " $t=k/I^2$ " 4. Incorrect neutral selection	1. Correct threshold 2. Correct curve 3. Select curve type " $t=k$ " 4. Correct neutral adjustment
4	Rapid trip, with I3=Off	Iinst tripped	FN short-circuit with high I
5	Earth fault current beyond threshold	G function automatically inhibited but no trip occurs	FN
6	Expected trip does not happen	Function OFF	FN enable protection function
7	LEDs irregularly turned on		see par. 12.3.2
8	Unexpected trip		see par. 12.3.2
9	L LED (orange) flashing		FN

### 12.8.2. In the case of a fault

 **WARNING: If the PR121/P is suspected of being faulty, if there are signs of malfunctions or it has generated an unexpected trip, we advise you to strictly follow the recommendations below:**

1. Press the "i Test" button (within 48 hours of CB opening or within 24 hours if the operating temperature is in the  $-40^{\circ}..-25^{\circ}$  range) and make a note of the led that comes on, the type of CB, the number of poles, any accessories connected, In, Serial Number. After 48 or 24 hours, depending on the case, the data are not cancelled. Just the LED display is inhibited.
2. Prepare a brief description of the opening (what LEDs were displayed?, when did it happen?, how many times?, was it always under the same conditions? what type of load? what current? is the event reproducible?).
3. Send/communicate all the information collected, together with the circuit diagram for the circuit-breaker, to your nearest ABB Customer Support service.

The more the information given to the ABB Customer Support service is complete and accurate, the easier the technical analysis on the problem encountered will be, enabling us to take all action to help the user without delay.

 **WARNING: Letting a switch run with a fault that has not been remedied may lead to an apparatus malfunction or shutdown. Remove the apparatus immediately until it can be inspected or repaired if this situation may lead to personal injury, damage or is otherwise critical.**

Model	B2342	B2410		Apparatus	<b>Emax</b>	Scale
				Doc. no.	<b>1SDH000460R0002</b>	Page No <b>46/74</b>

## 12.9. External units

### 12.9.1. PR030/B

PR030/B is an external unit that allows the relay to be powered in order to perform installation, Autotest and Trip Test, and the verifications with the CB open. The unit is connected to the relay by means of the front connector.

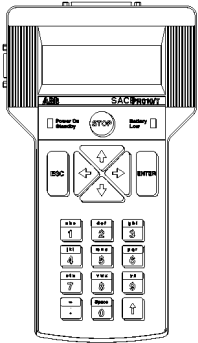
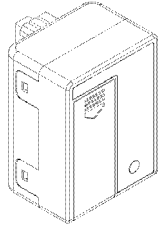

### 12.9.2. PR010/T

The SACE PR010/T unit allows the parameters and log data recorded by the relay to be checked. It also allows threshold operation to be checked as well as the tripping times of the L-S-I-G protection functions. The unit is supplied in a case containing the connection cables, external power supplier and rechargeable batteries, cable and SW for PC.

The SW in the PC allows several files corresponding to the devices with which it is possible to interface, to be loaded into PR010/T. It also allows test reports to be downloaded. Thus the corresponding file must be loaded into the PR010/T unit before it can be used with relay PR121.

The unit is connected to the relay by means of the front connector using a dedicated cable. Consult the Operation Manual of the unit (RH0025) for further details.

### 12.9.3. BT030-USB

Using the BT030-USB unit, PR121/P can communicate with a PC via wireless link or USB flash drive, thereby extending the range of information available to the user.

Communication is enabled via Ekip Connect SW, the installation package of which is in the BT030-USB set. This set also includes the USB cable for use in the wireless configuration.

The unit is connected to the relay by means of the front connector.

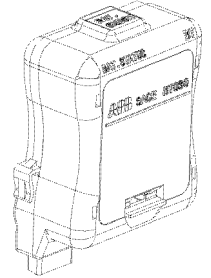

### 12.9.4. EKIP T&P

The Ekip T&P unit allows relay powering, communication and testing via a PC by means of a USB adapter. Similarly to BT030-USB, communication is enabled via Ekip Connect SW, the installation package of which is in the Ekip T&P set. The set includes the USB module and a series of adapters for various types of relay.

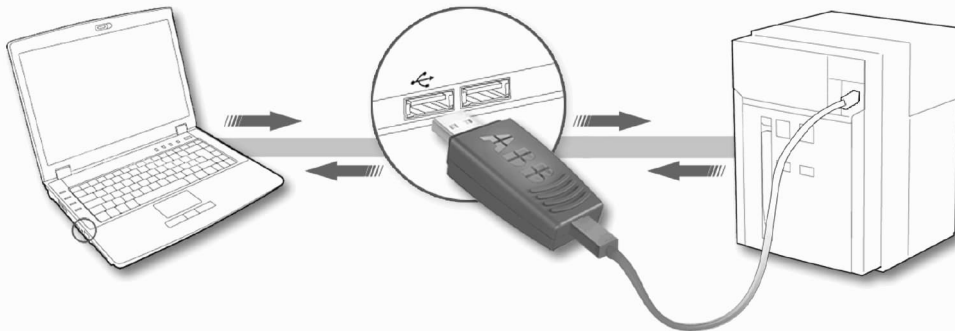

**WARNING:** Ekip T&P must be used for PR121/P with USB module and a dedicated cable for PR121/P (the picture below is for explanatory purposes only). Consult the Ekip Connect SW Operation Manual (1SDH000891R0001) for further details.

### 12.9.5. HMI030

PR121/P can also be connected to the HMI030 switchgear front external unit so as to display the current values measured.

HMI030 connects to the connector on the rear side, on the relay, whose external connection is provided by the contacts on the terminal box in the CB.

Auxiliary power supply for the relay and HMI030 is not required for this function.

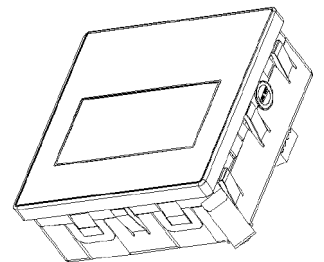

#### HMI030 power supply

Auxiliary power supply	24 V DC +/-20%
Maximum ripple	5%
Rated power @ 24 V	1,2W

Consult the Operation Manual of the unit (1SDH000573R0001) for further details.

Model	B2342	B2410		Apparatus	<b>Emax</b>	Scale
				Doc. No	<b>1SDH000460R0002</b>	Page No <b>47/74</b>

### 12.9.6. Flex interface

Flex interfaces are electronic units that can be installed on DIN rail, with analog and/or digital inputs and outputs that can be connected to the PR121/P relay via Local Bus.

The Flex Interface family for PR121/P relays consists of the MM030 module (connected on one side to the Local Bus of the relay and on the other to all the modules used) and AD series modules. If connected to MM030, the HMI030 module is also part of the Flex Interface family. All the configurations and connection solutions are described in the dedicated operation manuals (as shown in the attached table).

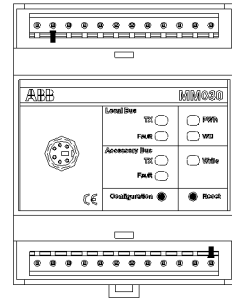

Auxiliary power supply for the relay and Flex Interface is required for this function.

Device	Characteristics	Description	Notes	Reference documentation
MM030		Controls exchanges of information between the relay and accessories of the Flex Interface family		1SDH000622R0001
AD030 DO	8 digital outputs	Receives information from MM03 and operates its digital outputs as a consequence		1SDH000672R0001
AD030 AO	4 analog outputs	Receives information from MM03 and operates its analog outputs as a consequence		1SDH000672R0001
AD030 MI	mixed inputs: 2 analog and 2 digital	Repeats the digital inputs following a request from the MM03		1SDH000672R0001
HMI030	Display	Displays the data received from the relay or MM030	note 1: after being configured in the appropriate way, it can be connected to the relay or straight to the MM030	1SDH000573R0001
			note 2: the HMI030 can be connected to MM030 from MM030 software releases 2.0 onwards	

#### 12.9.6.1. Notes about the HMI030 and Flex Interface connection

Relay connection for HMI030 or Flex Interface units must be made with a shielded stranded two-wire cable (BELDEN 3105A for example) up to 15 m in length. The shield must be earthed on both the circuit-breaker and unit sides.

### 12.9.7. Ekip Connect

Ekip Connect is a software application for personal computers equipped with the Microsoft Windows® operating system, which allows data to be exchanged with one or more ABB low voltage devices.

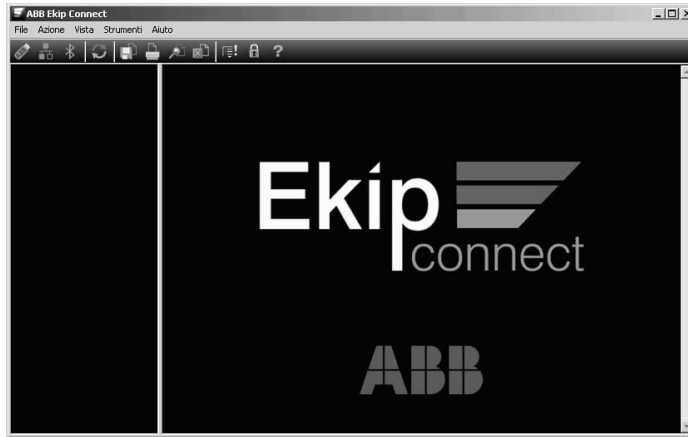

Ekip Connect can be connected to ABB low voltage circuit-breakers equipped with electronic protection relays for the purpose of:

- Putting the CB into service.
- Monitoring the state of all the available signals.
- Reading information (alarms, measurements, parameters).
- Modifying the configuration parameters, especially for protection relays without displays.
- Executing commands.
- Troubleshooting for the relay and communication network.
- Performing tests.

Operating tests in switchboards are facilitated since the parameters and test reports can be saved.

Ekip Connect is free of charge and is either supplied on an installation CD or can be obtained from the Internet address <http://bol.it.abb.com> in the section "Work Tools - Software for moulded case and air circuit-breakers".

Model	B2342	B2410		Apparatus	<b>Emax</b>	Scale
				Doc. no.	<b>1SDH000460R0002</b>	Page No <b>48/74</b>



# 13. Overall dimensions

## Fixed circuit-breaker

Basic version with horizontal rear terminals

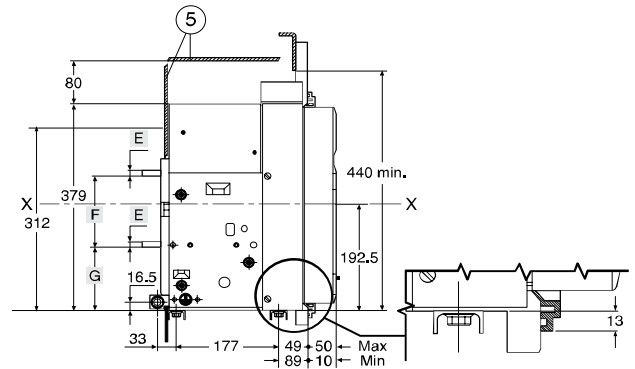
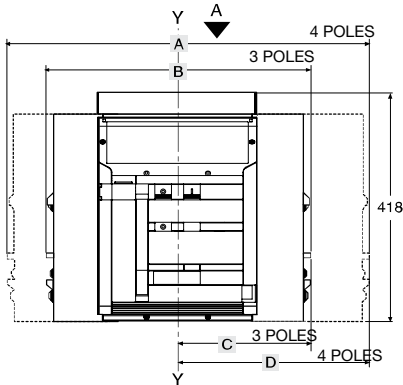

### Legend

- ① Inside edge of compartment door
- ② Segregation (where foreseen)
- ③ Circuit-breaker M10 fixing drilling (use M10 screws)
- ④ N° 1 M12 screw (E1, E2, E3) or n° 2 M12 screws (E4, E6) for earthing (included in the supply)
- ⑤ Insulating or metal-insulated wall

**E1/E2**  
View A

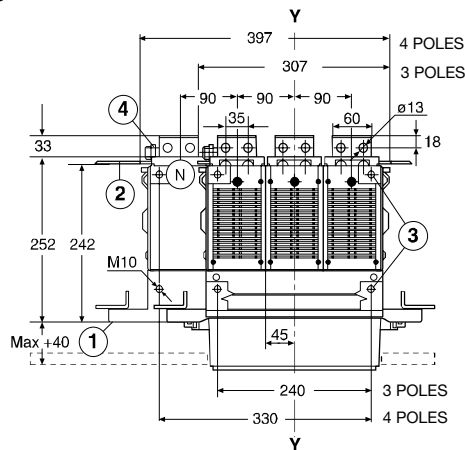

**E3**  
View A

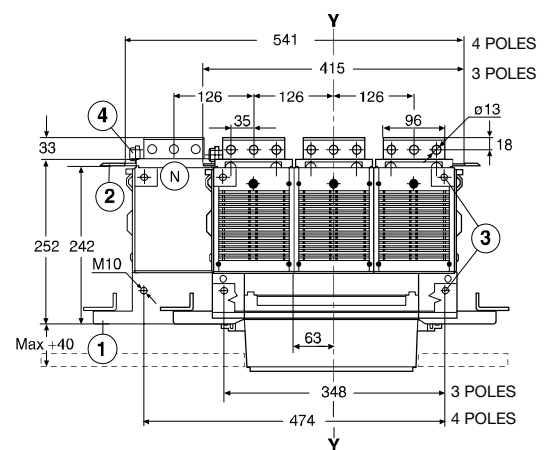

	A	B	C	D	E	F	G
<b>E1</b>	386	296	148	148	10	130	117,5
<b>E2</b>	386	296	148	148	26	114	117,5
<b>E3</b>	530	404	202	202	26	114	117,5
<b>E4</b>	656	566	238	328	26	166	91,5
<b>E4/f</b>	746	-	-	328	26	166	91,5
<b>E6</b>	908	782	328	454	26	166	91,5
<b>E6/f</b>	1034	-	-	454	26	166	91,5

Model	B2342	B2410		Apparatus	<b>Emax</b>	Scale
				Doc. No	<b>1SDH000460R0002</b>	Page No 49/74

# Fixed circuit-breaker

Basic version with horizontal rear terminals

**E4**  
View A

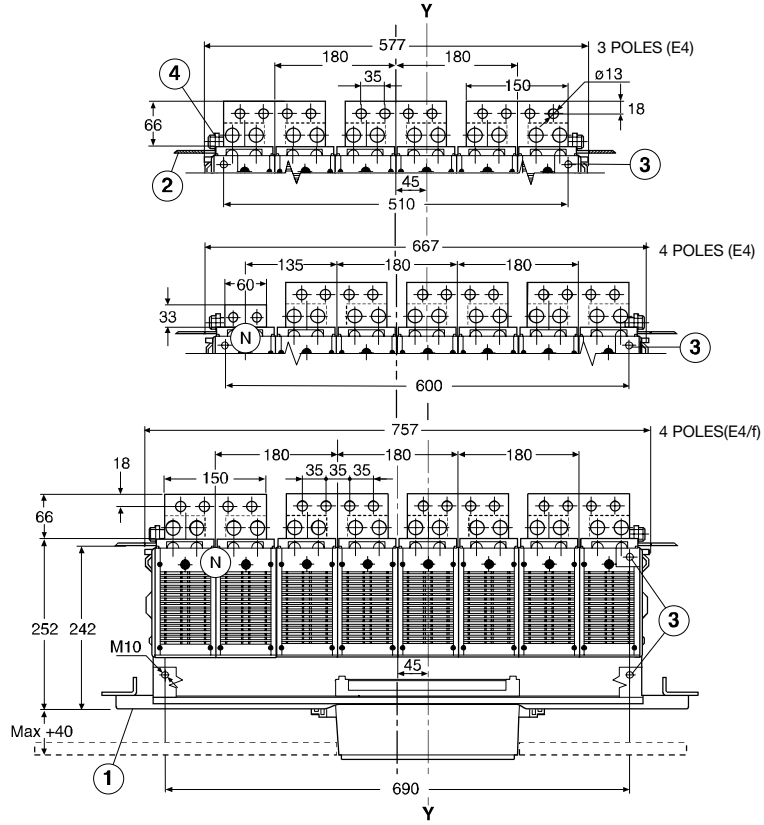

**E6**  
View A

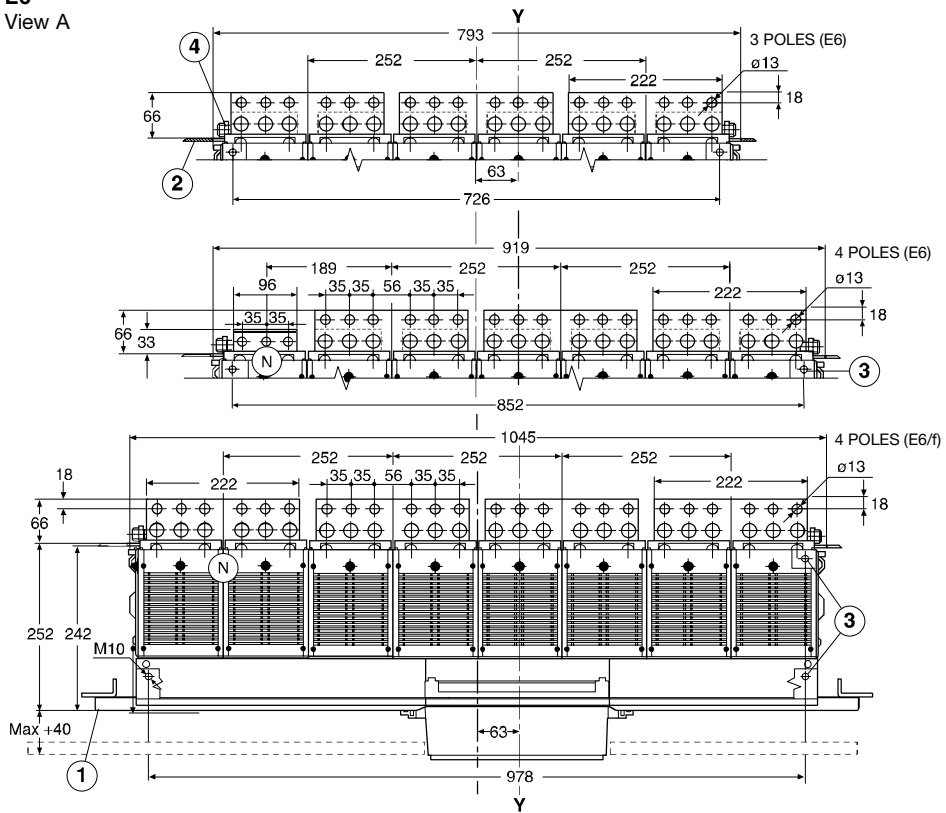

Fig. 36

Model	B2342	B2410		Apparatus	<b>Emax</b>	Scale
				Doc. no.	<b>1SDH000460R0002</b>	Page No 50/74

# Fixed circuit-breaker

Basic version with vertical rear terminals

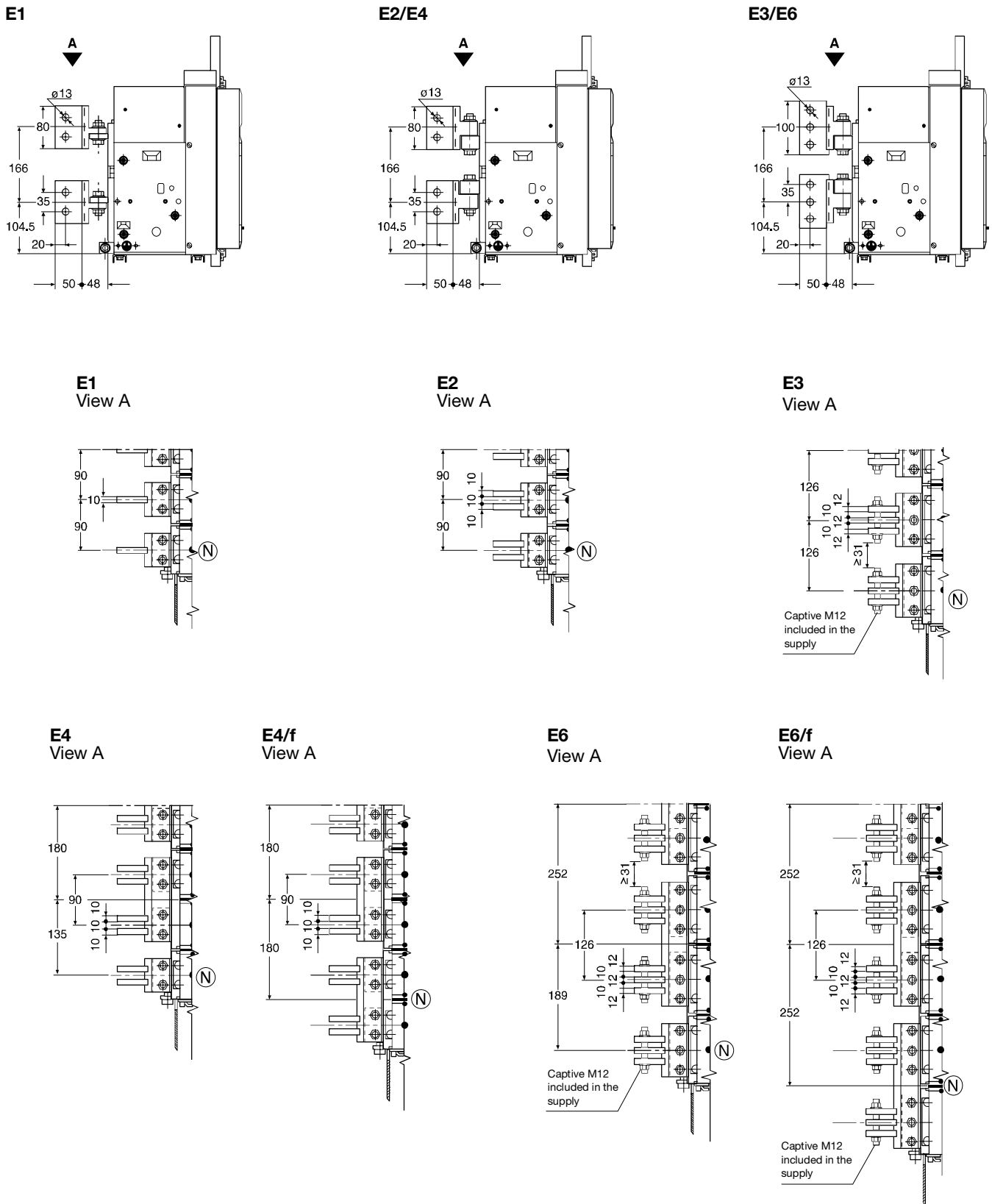

Fig. 36a

Model	B2342	B2410	Apparatus	<b>Emax</b>	Scale
			Doc. No	<b>1SDH000460R0002</b>	Page No <b>51/74</b>

# Fixed circuit-breaker

Basic version with front terminals

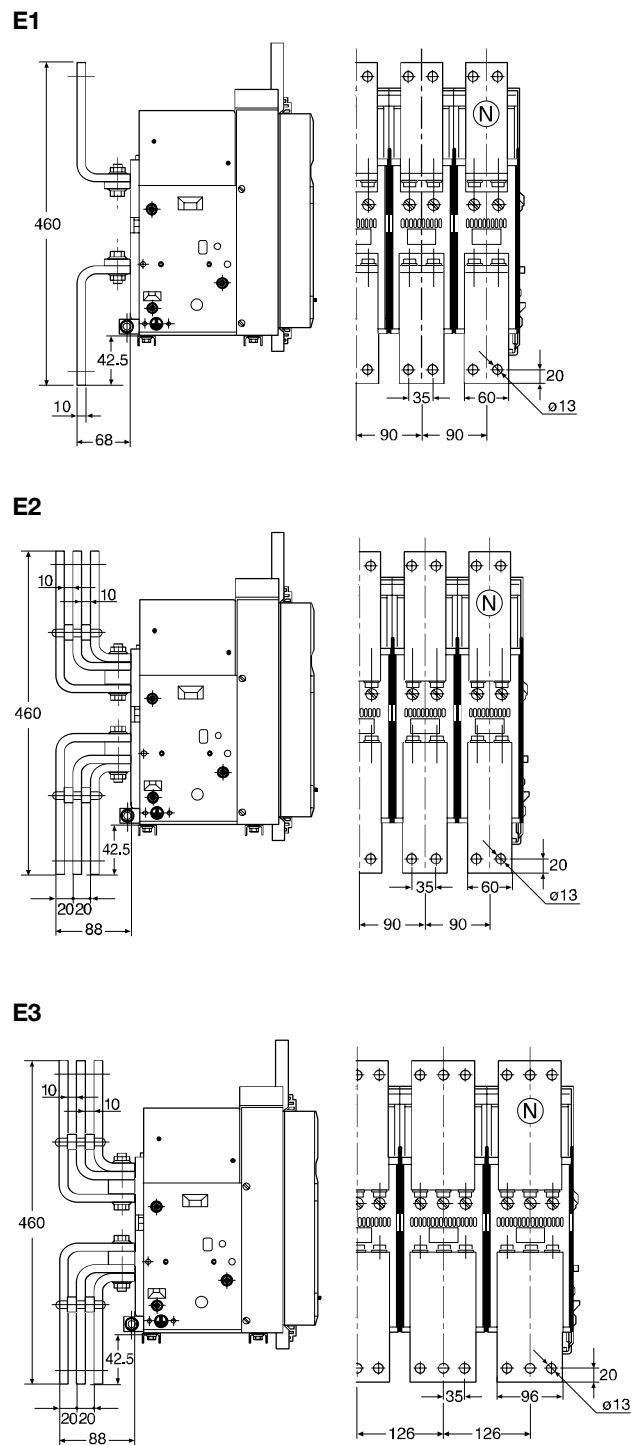

Fig. 37 \_\_\_\_\_

Model	B2342	B2410		Apparatus	<b>Emax</b>	Scale
				Doc. no.	<b>1SDH000460R0002</b>	Page No <b>52/74</b>

# Fixed circuit-breaker

Basic version with front terminals

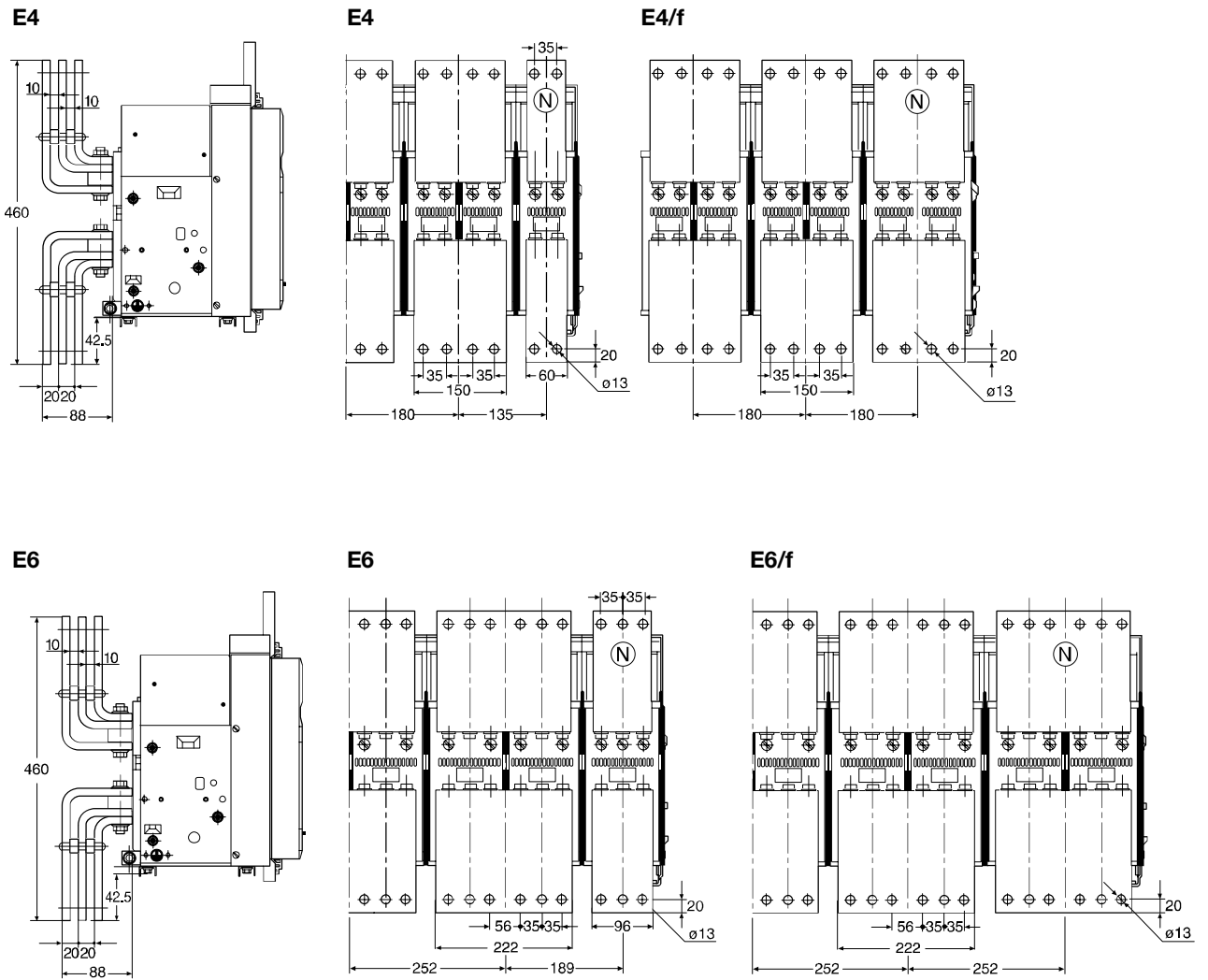
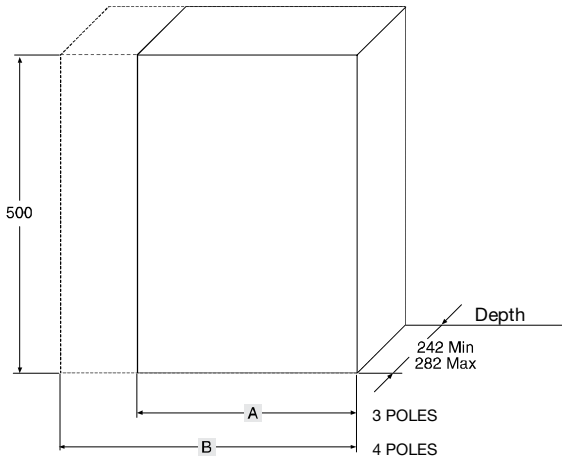

Fig. 38

Model	B2342	B2410		Apparatus	<b>Emax</b>	Scale
				Doc. No	<b>1SDH000460R0002</b>	Page No 53/74

Compartment dimensions



Compartment door drilling

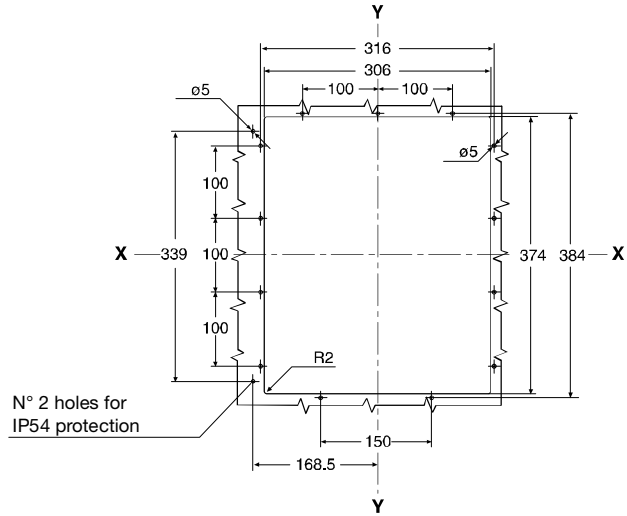

Holes for passing through flexible cables for mechanical interlocks

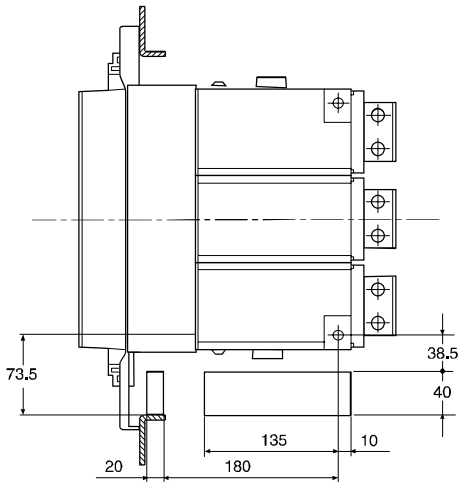

Tightening torque of the main terminals: Nm 70  
Tightening torque of the earthing screw: Nm 70

	High resistance M12 screw Quantity per terminal	
	PHASE	NEUTRAL
E1-E2	2	2
E3	3	3
E4-E4/f	4	2-4
E6-E6/f	6	3-6

	A	B
E1	400	490
E2	400	490
E3	500	630
E4	700	790
E4/f	-	880
E6	1000	1130
E6/f	-	1260

Fig. 39

Model	B2342	B2410		Apparatus	<b>Emax</b>	Scale
				Doc. no.	<b>1SDH000460R0002</b>	Page No <b>54/74</b>

# Withdrawable circuit-breaker

Basic version with horizontal rear terminals

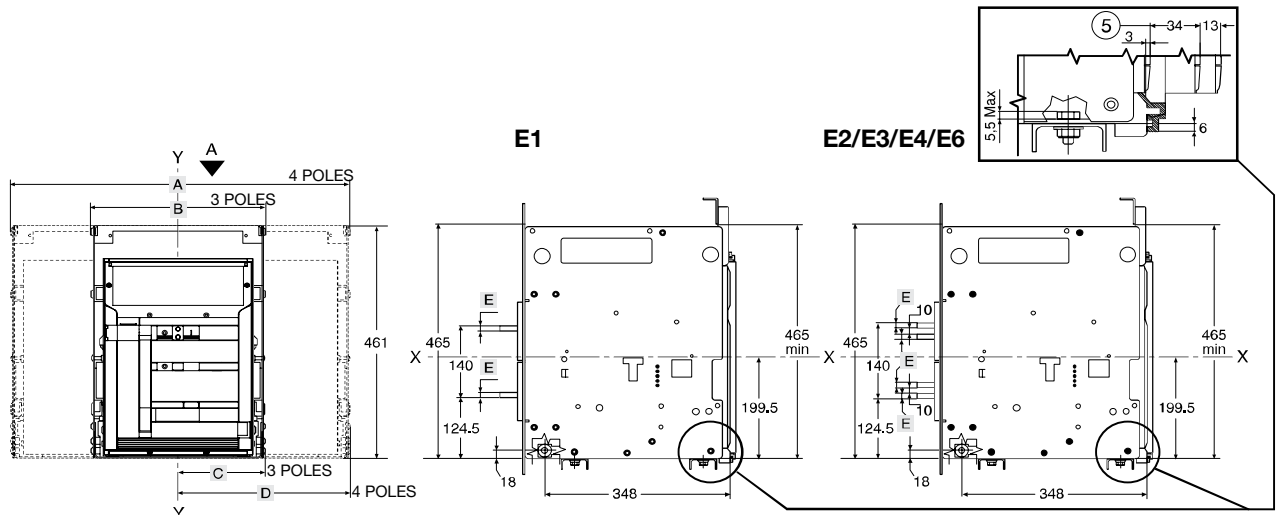

## Legend

- ① Inside edge of compartment door
- ② Segregation (where foreseen)
- ③ Fixing fixed part  $\varnothing 10$  drilling (use M8 screws)
- ④ N° 1 M12 screw (E1, E2, E3) or n° 2 M12 screws (E4, E6) for earthing (included in the supply)
- ⑤ Run from connected for a TEST to isolated
- ⑥ Alternative drilling with 25mm pitch for fixing fixed part
- ⑦ Ventilation drilling on the switchgear

**E1/E2**  
View A

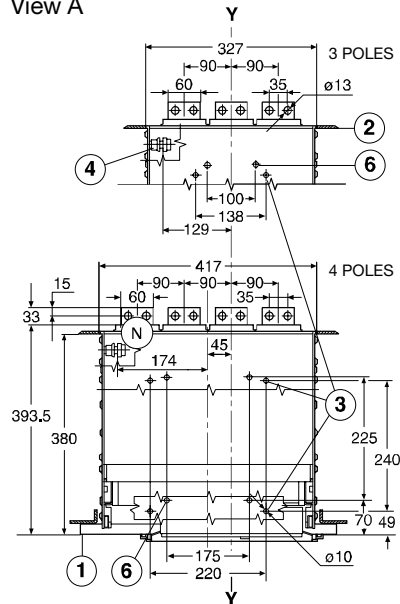

**E3**  
View A

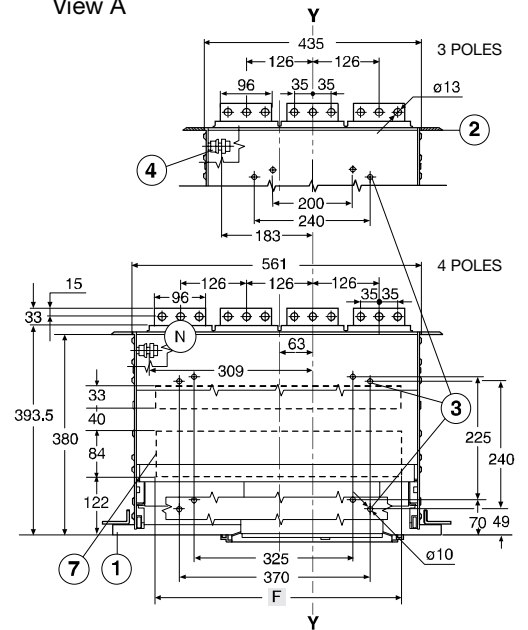

	A	B	C	D	E	F	
						3 poles	4 poles
<b>E1</b>	414	324	162	162	10	-	-
<b>E2</b>	414	324	162	162	8	-	-
<b>E3</b>	558	432	216	216	8	370	490
<b>E4</b>	684	594	252	342	8	530	610
<b>E4/f</b>	774	-	-	342	8	-	700
<b>E6</b>	936	810	342	468	8	750	870
<b>E6/f</b>	1062	-	-	468	8	-	1000

Fig. 40

Model	B2342	B2410		Apparatus	<b>Emax</b>	Scale
				Doc. No	<b>1SDH000460R0002</b>	Page No 55/74

**Withdrawable circuit-breaker**

Basic version with horizontal rear terminals

**E4  
View A**

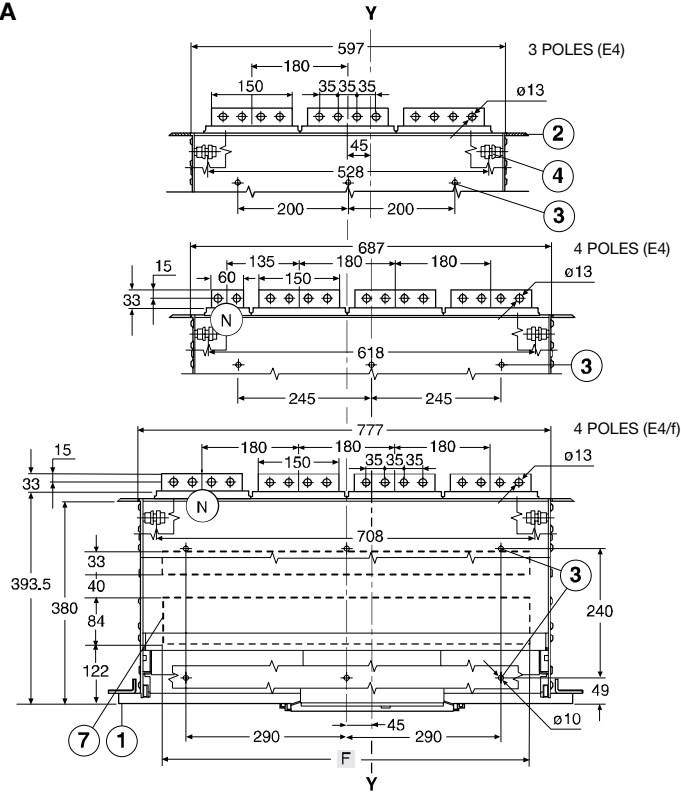

**E6  
View A**

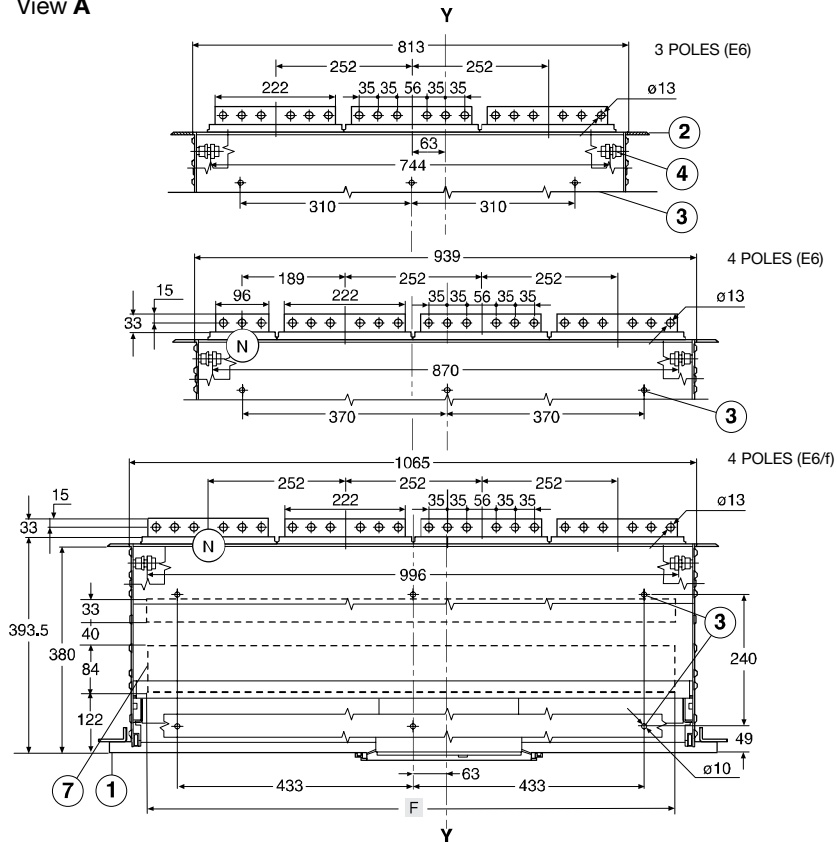

Fig. 41

Model	B2342	B2410		Apparatus	<b>Emax</b>	Scale
				Doc. no.	<b>1SDH000460R0002</b>	Page No <b>56/74</b>



# Withdrawable circuit-breaker

Basic version with vertical rear terminals

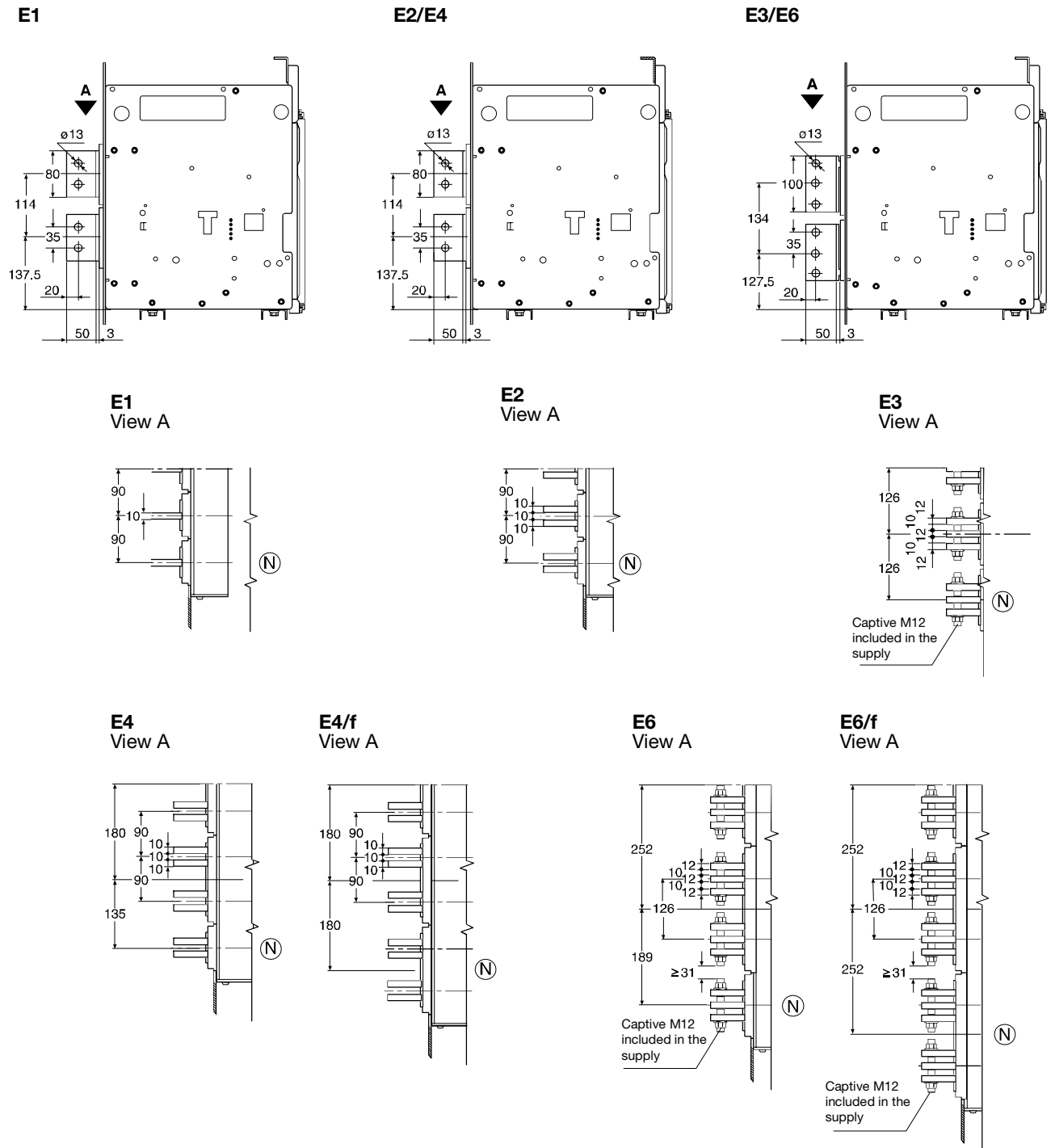

Fig. 42

Model	B2342	B2410		Apparatus	<b>Emax</b>	Scale
				Doc. No	<b>1SDH000460R0002</b>	Page No <b>57/74</b>

# Withdrawable circuit-breaker

Version with front terminals

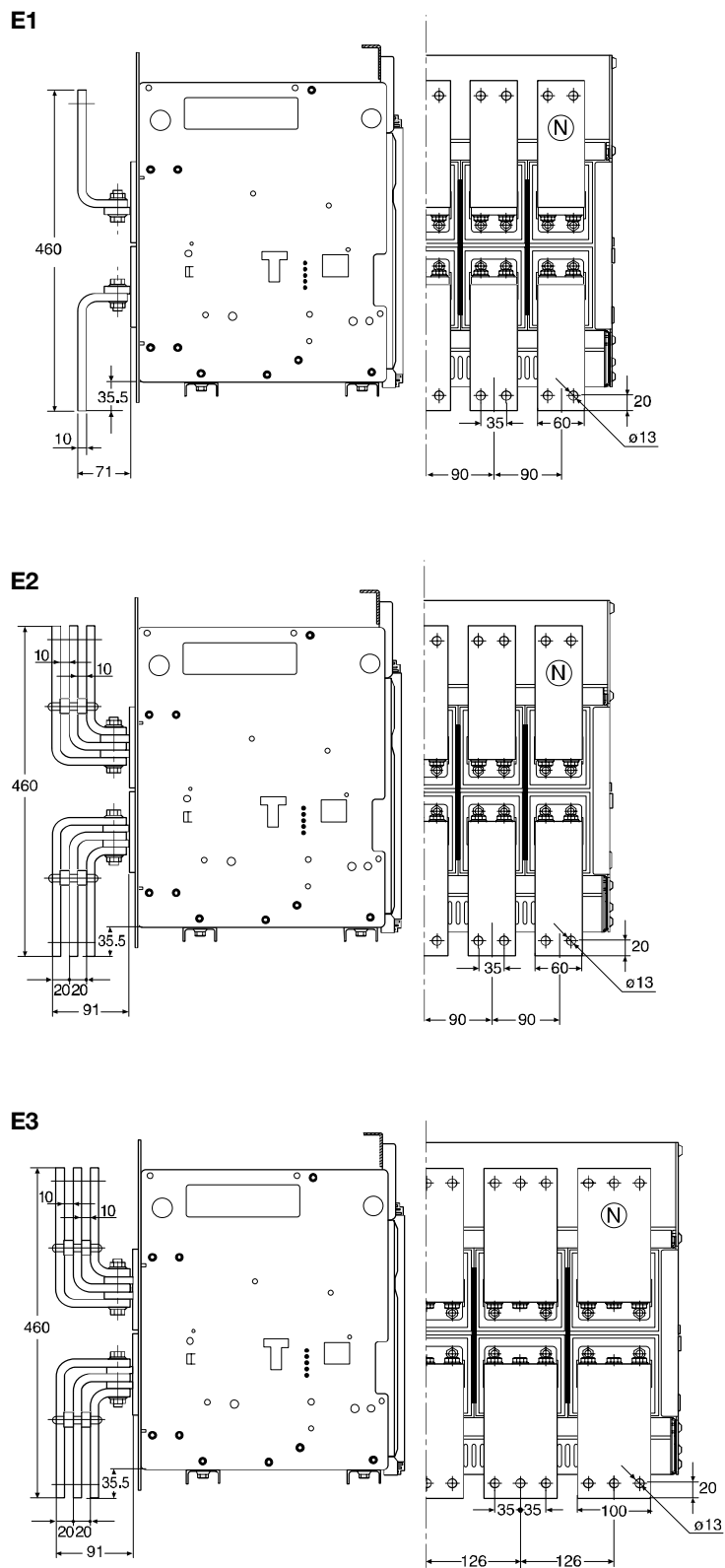

Fig. 43 \_\_\_\_\_

Model	B2342	B2410		Apparatus	<b>Emax</b>	Scale
				Doc. no.	<b>1SDH000460R0002</b>	Page No <b>58/74</b>

**Withdrawable circuit-breaker**

Version with front terminals

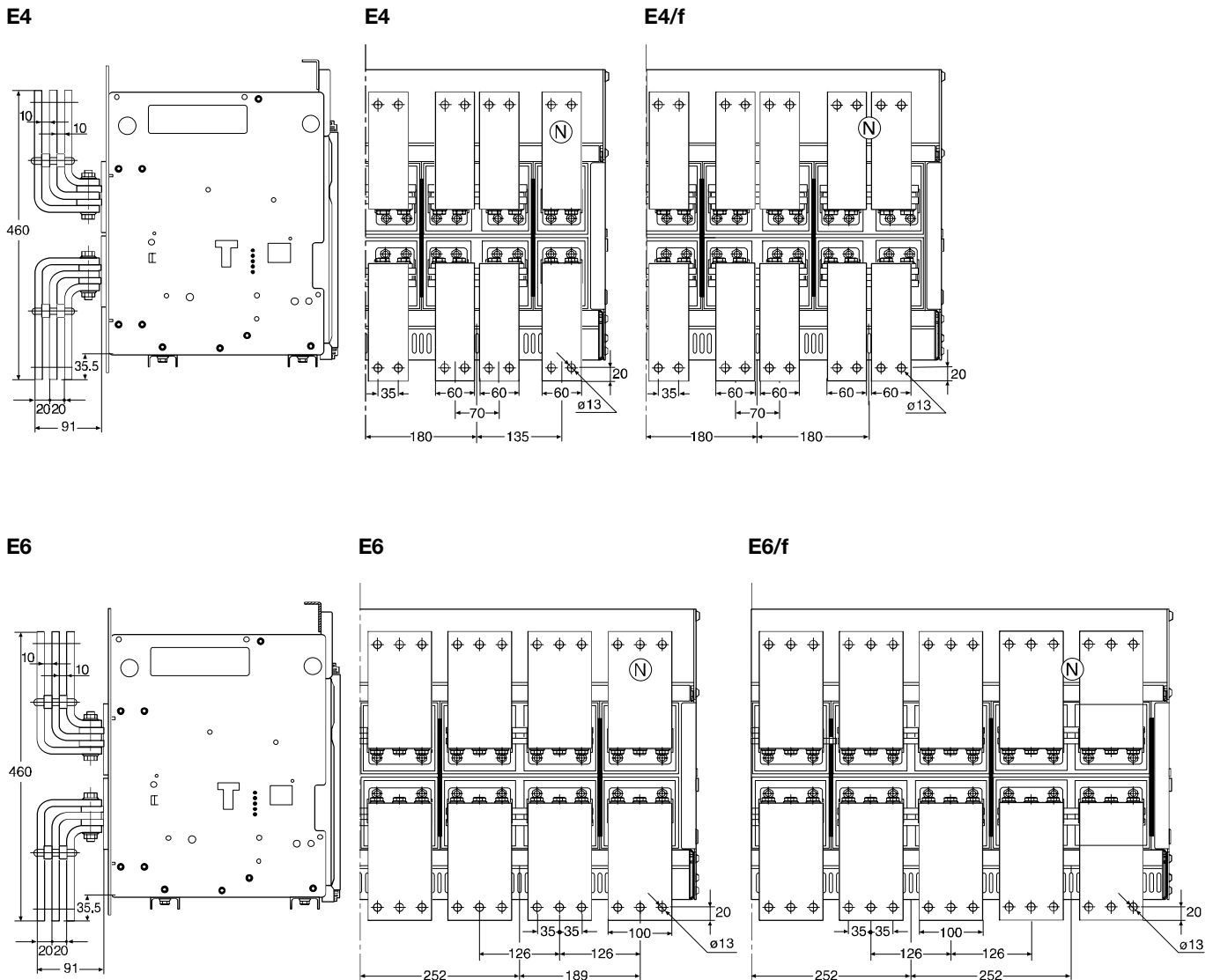

Fig. 44

Model	B2342	B2410		Apparatus	<b>Emax</b>	Scale
				Doc. No	<b>1SDH000460R0002</b>	Page No <b>59/74</b>

**Withdrawable circuit-breaker**

Version with flat terminals

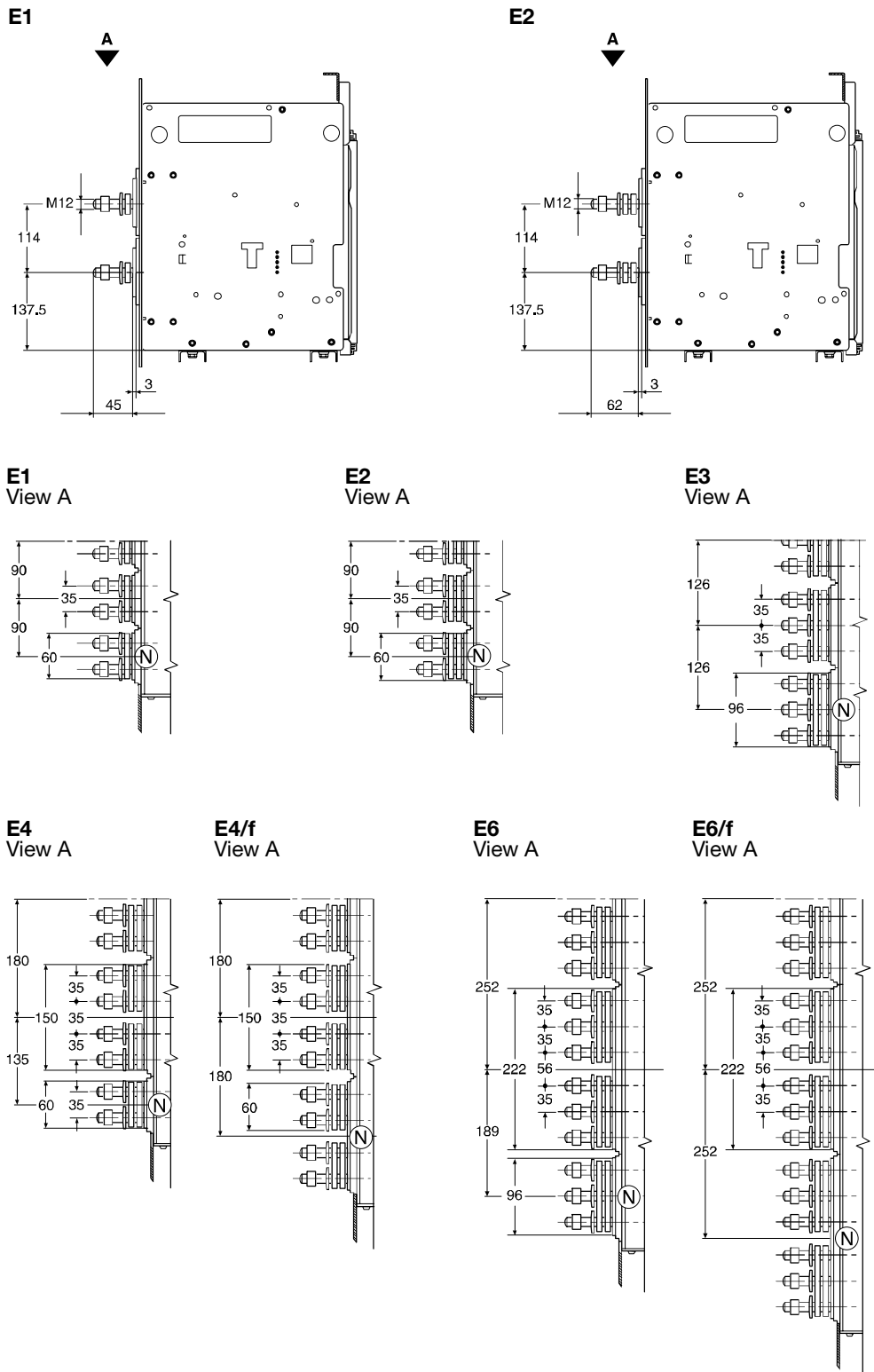
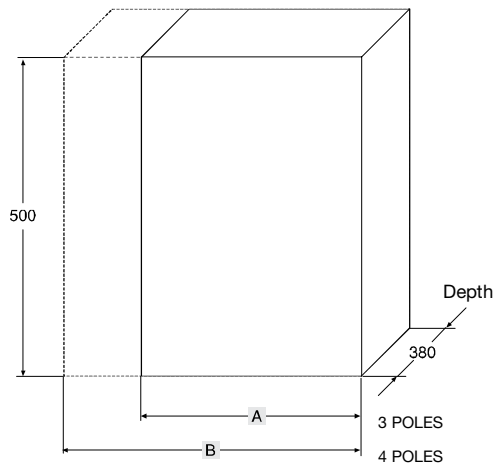

Fig. 45 \_\_\_\_\_

Model	B2342	B2410		Apparatus	<b>Emax</b>	Scale
				Doc. no.	<b>1SDH000460R0002</b>	Page No <b>60/74</b>

# Withdrawable circuit-breaker

## Compartment dimensions



## Compartment door drilling

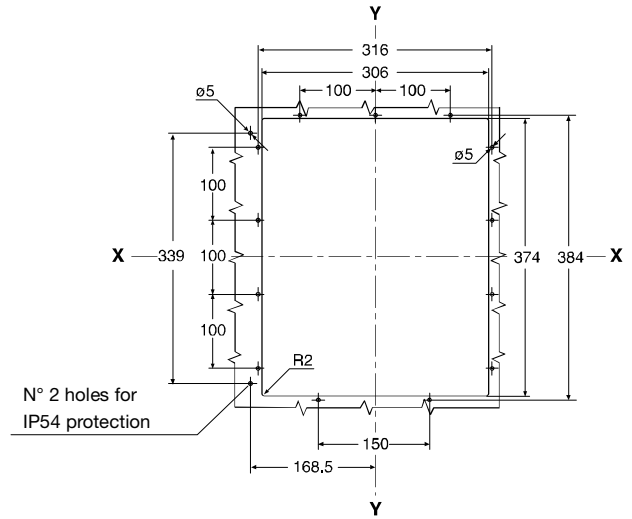

## Holes for passing through flexible cables for mechanical interlocks

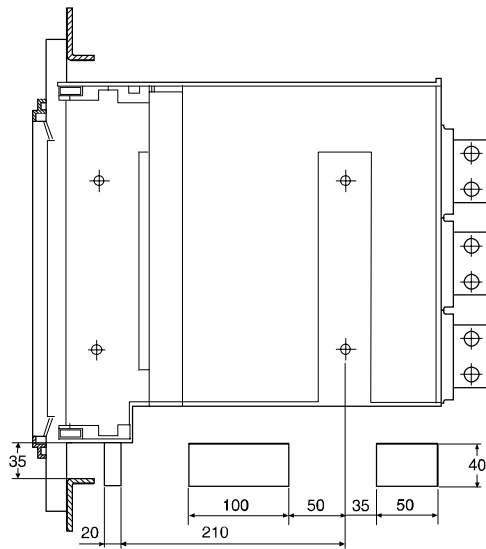

**Tightening torque of the fixing screws: 20 Nm**  
**Tightening torque of the main terminals: 70 Nm**  
**Tightening torque of the earthing screw: 70 Nm**

High resistance M12 screw  
 Qty per terminal

	PHASE	NEUTRAL
<b>E1-E2</b>	2	2
<b>E3</b>	3	3
<b>E4-E4/f</b>	4	2-4
<b>E6-E6/f</b>	6	3-6

	A	B
<b>E1</b>	400	490
<b>E2</b>	400	490
<b>E3</b>	500	630
<b>E4</b>	700	790
<b>E4/f</b>	-	880
<b>E6</b>	1000	1130
<b>E6/f</b>	-	1260

Fig. 46

Model	B2342	B2410	Apparatus	<b>Emax</b>	Scale
			Doc. No	<b>1SDH000460R0002</b>	Page No <b>61/74</b>

# Compartment door mechanical lock

Door drilling

Minimum distance between the circuit-breaker and the switchgear wall

Fixed version

Withdrawable version

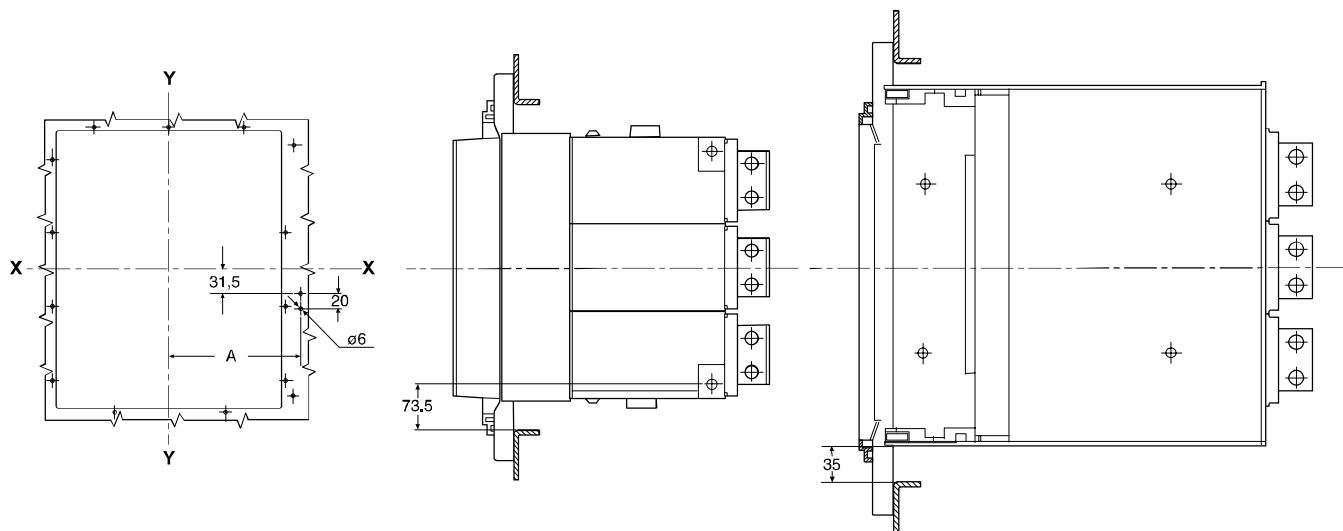

	A	
	3 POLES	4 POLES
E1	180	180
E2	180	180
E3	234	234
E4	270	360
E4/f	-	360
E6	360	486
E6/f	-	486

Fig. 47

Model	B2342	B2410		Apparatus	<b>Emax</b>	Scale
				Doc. no.	<b>1SDH000460R0002</b>	Page No <b>62/74</b>

## 14. Circuit diagrams



**WARNING:**  
Before installing the circuit-breaker, carefully read notes F and O on the circuit diagrams.

### Operating status shown

The circuit diagram is for the following conditions:  
 - withdrawable circuit-breaker, open and racked-in  
 - circuits de-energised  
 - releases not tripped  
 - motor operating mechanism with springs unloaded.

### Versions

The diagram shows a circuit-breaker in withdrawable version; it can be applied to a fixed version circuit-breaker as well.

#### Fixed version

The control circuits are fitted between terminals XV (connector X is not supplied).  
 With this version, the applications indicated in figures 31 and 32 cannot be provided.

#### Withdrawable version

The control circuits are fitted between the poles of connector X (terminal box XV is not supplied).

#### Version without overcurrent release

With this version, the applications indicated in figures 13, 14, 41, 42, 43, 44, 45, 46, 47, 48, 62 cannot be provided.

#### Version with PR121/P electronic release

With this version, the applications indicated in figures 42, 43, 44, 45, 46, 47, 48 cannot be provided.

#### Version with PR122/P electronic release

With this version, the applications indicated in figure 41 cannot be provided.

#### Version with PR123/P electronic release

With this version, the applications indicated in figure 41 cannot be provided.

### Caption

- = Circuit diagram figure number
- \* = See note indicated by the letter
- A1 = Circuit-breaker accessories
- A3 = Accessories applied to the fixed part of the circuit-breaker (for withdrawable version only)
- A4 = Example switchgear and connections for control and signalling, outside the circuit-breaker
- A13 = PR021/K signalling unit (outside the circuit-breaker)
- AY = SACE SOR TEST UNIT Test/monitoring Unit (see note R)
- D = Electronic time-delay device of the undervoltage release, outside the circuit-breaker
- F1 = Delayed-trip fuse
- K51 = PR121/P, PR122/P, PR123/P electronic release with the following protection functions:
  - L overload protection with inverse long time-delay trip-setting I1
  - S short-circuit protection with inverse or definite short time-delay trip-setting I2
  - I short-circuit protection with instantaneous time-delay trip-setting I3
  - G earth fault protection with inverse short time-delay trip-setting I4
- K51/1...8 = Contacts for the PR021/K signalling unit
- K51/GZin(DBin) = Zone selectivity: for protection G (only with Vaux and PR122/P or PR123/P release) or "reverse" direction input for protection D (only with Vaux and PR123/P release)
- K51/GZout(DBout) = Zone selectivity: for protection G (only with Vaux and PR122/P or PR123/P release) or "reverse" direction output for protection D (only with Vaux and PR123/P release)
- K51/IN1 = Digital programmable input (available only with Vaux and release PR122/P or PR123/P with indicator module PR120/K)
- K51/P1...P4 = Programmable electrical signalling (available only with Vaux and release PR122/P or PR123/P with indicator module PR120/K)
- K51/SZin(Dfin) = Zone selectivity: input for protection S or "direct" input for protection D (only with Vaux and PR122/P or PR123/P release)
- K51/SZout(DFout) = Zone selectivity: output for protection S or "direct" output for protection D (only with Vaux and PR122/P or PR123/P release)
- K51/YC = Closing control from PR122/P or PR123/P electronic release with communication module PR120/D-M
- K51/YO = Opening control from PR122/P or PR123/P electronic release with communication module PR120/D-M
- M = Motor for loading the closing springs
- Q = Circuit-breaker
- Q/1...27 = Circuit-breaker auxiliary contacts
- S33M/1...3 = Limit contacts for spring-loading motor
- S43 = Switch for setting remote/local control
- S51 = Contact for electrical signalling of circuit-breaker open due to tripping of the overcurrent release. The circuit-breaker may be closed only after pressing the reset pushbutton, or after energizing the coil for electrical reset (if available)

Model	B2342	B2410		Apparatus	<b>Emax</b>	Scale
				Doc. No	<b>1SDH000460R0002</b>	Page No <b>63/74</b>

- S75E/1.4 = Contacts for electrical signalling of circuit-breaker in disconnected position (only with withdrawable circuit-breakers)
- S75I/1..5 = Contacts for electrical signalling of circuit-breaker in connected position (only with withdrawable circuit-breakers)
- S75T/1..4 = Contacts for electrical signalling of circuit-breaker in test isolated position (only with withdrawable circuit-breakers)
- SC = Pushbutton or contact for closing the circuit-breaker
- SO = Pushbutton or contact for opening the circuit-breaker
- SO1 = Pushbutton or contact for opening the circuit-breaker with delayed trip
- SO2 = Pushbutton or contact for opening the circuit-breaker with instantaneous trip
- SR = Pushbutton or contact for electrical circuit-breaker reset
- TI/L1 = Current transformer located on phase L1
- TI/L2 = Current transformer located on phase L2
- TI/L3 = Current transformer located on phase L3
- TO = Homopolar toroidal current transformer (see note W)
- Vaux = Auxiliary power supply voltage (see note F)
- UI/L1 = Current sensor (Rogowski coil) located on phase L1
- UI/L2 = Current sensor (Rogowski coil) located on phase L2
- UI/L3 = Current sensor (Rogowski coil) located on phase L3
- UI/N = Current sensor (Rogowski coil) located on neutral
- UI/0 = Current sensor (Rogowski coil) located on the conductor connecting to earth the star point of the MV/LV transformer (see note G)
- W1 = Serial interface with control system (external bus): EIA RS485 interface (see note E)
- W2 = Serial interface with the accessories of PR121/P, PR122/P and PR123/P releases (internal bus)
- X = Delivery connector for auxiliary circuits of withdrawable version circuit-breaker
- X1...X7 = Connectors for the accessories of the circuit-breaker
- XF = Delivery terminal box for the position contacts of the withdrawable circuit-breaker (located on the fixed part of the circuit-breaker)
- XK1 = Connector for power circuits of PR121/P, PR122/P and PR123/P releases
- XK2 - XK3 = Connectors for auxiliary circuits of PR121/P, PR122/P and PR123/P releases
- XK4 = Connector to signal open/close
- XK5 = PR120/V module connector
- XO = Connector for YO1
- XV = Delivery terminal box for the auxiliary circuits of the fixed circuit-breaker
- YC = Shunt closing release
- YO = Shunt opening release
- YO1 = Trip coil
- YO2 = Second shunt opening release (see note Q)
- YR = Coil to electrically reset the circuit-breaker
- YU = Undervoltage release (see notes B and Q)

#### Figures Description

- Fig. 1 = Motor circuit to load the closing springs.
- Fig. 2 = Circuit of shunt closing release.
- Fig. 4 = Shunt opening release.
- Fig. 6 = Instantaneous undervoltage release (see notes B and Q).
- Fig. 7 = Undervoltage release with electronic time-delay device, outside the circuit-breaker (see notes B and Q)
- Fig. 8 = Second shunt opening release (see note Q).
- Fig.11 = Contact for electrical signalling of springs loaded.
- Fig.12 = Contact for electrical signalling of undervoltage release energized (see notes B and S).
- Fig.13 = Contact for electrical signalling of circuit-breaker open due to tripping of the overcurrent release. The circuit-breaker may be closed only after pressing the reset pushbutton.
- Fig.14 = Contact for electrical signalling of circuit-breaker open due to tripping of the overcurrent release and electrical reset coil. The circuit-breaker may be closed only after pressing the reset pushbutton or energizing the coil.
- Fig.21 = First set of circuit-breaker auxiliary contacts.
- Fig.22 = Second set of circuit-breaker auxiliary contacts (not available for PR122/P and PR123/P releases)(see note V)
- Fig.23 = Third set of supplementary auxiliary contacts outside the circuit-breaker.
- Fig.31 = First set of contacts for electrical signalling of circuit-breaker in connected, test isolated, disconnected position.
- Fig.32 = Second set of contacts for electrical signalling of circuit-breaker in connected, test isolated, disconnected position.
- Fig.41 = Auxiliary circuits of PR121/P release (see note F).
- Fig.42 = Auxiliary circuits of PR122/P and PR123/P releases (see notes F, M and V).
- Fig.43 = Circuits of the measuring module PR120/V of the PR122/P and PR123/P releases internally connected to the three-pole and four-pole circuit-breaker (optional for the release PR122/P) (see note U).
- Fig.44 = Circuits of the measuring module PR120/V of the PR122/P and PR123/P releases externally connected to the circuit-breaker (optional for the release PR122/P) (see note O, U and X).
- Fig.45 = Circuits of the communication module PR120/D-M of the PR122/P and PR123/P releases (optional) (see note E).
- Fig.46 = Circuits of the indicator module PR120/K of the PR122/P and PR123/P releases - connection 1 (optional) (see note V).

Model	B2342	B2410		Apparatus	<b>Emax</b>	Scale
				Doc. no.	<b>1SDH000460R0002</b>	Page No <b>64/74</b>



- Fig. 47 = Circuits of the indicator module PR120/K of the PR122/P and PR123/P releases - connection 2 (optional) (see note V).
- Fig. 48 = Circuits of the measuring module PR120/V of the PR122/P and PR123/P releases connected inside the three-pole circuit-breaker with outside neutral conductor (optional for the release PR122/P)(see note U).
- Fig. 61 = SACE SOR TEST UNIT Test/monitoring Unit (see note R)
- Fig. 62 = Circuits of the signalling unit PR021/K (outside the circuit-breaker).

### Incompatibilities

The circuits indicated in the following figures cannot be supplied simultaneously on the same circuit-breaker:







- 6 - 7 - 8  
13 - 14  
22 - 46 - 47  
43 - 44 - 48

### Notes

- A) The circuit-breaker is only fitted with the accessories specified in the ABB SACE order acknowledgement. Consult this catalogue for information on how to make out an order.
- B) The undervoltage release is supplied for operation using a power supply branched on the supply side of the circuit-breaker or from an independent source. The circuit-breaker can only close when the release is energized (there is a mechanical lock on closing).  
If the same power supply is used for the closing and undervoltage releases and the circuit-breaker is required to close automatically when the auxiliary power supply comes back on, a 30 ms delay must be introduced between the undervoltage release accept signal and the energizing of the closing release. This may be achieved using an external circuit comprising a permanent make contact, the contact shown in fig. 12 and a time-delay relay.
- E) For connecting the EIA RS485 serial line, see "Technical Application Book – volume 9" communication via BUS with the ABB switches.
- F) The auxiliary voltage Vaux allows actuation of all operations of the PR121/P, PR122/P and PR123/P releases.  
Having requested a Vaux insulated from earth, one must use "galvanically separated converters" in compliance with IEC 60950 (UL 1950) or equivalent standards that ensure a common mode current or leakage current (see IEC 478/1, CEI 22/3) not greater than 3.5 mA, IEC 60364-41 and CEI 64-8.
- G) Earth fault protection is available with the PR122/P and PR123/P releases by means of a current sensor located on the conductor connecting to earth the star center of the MV/LV transformer.  
The connections between terminals 1 and 2 (or 3) of current transformer UI/O and poles T7 and T8 of the X (or XV) connector must be made with a two-pole shielded and stranded cable (type BELDEN 3105A/3105B) no more than 15m long. The shield must be earthed on the circuit-breaker side and current sensor side.
- N) With releases PR122/P and PR123/P, the connections to the zone selectivity inputs and outputs must be made with a two-pole shielded and stranded cable (type BELDEN 3105A/3105B), no more than 300m long. The shield must be earthed on the selectivity input side.
- O) Systems with a rated voltage greater than 690V require the use of an insulation voltage transformer to connect to the busbars (connect according to the diagrams on the sheet provided with the kit 1SDH000460R0508).
- P) With releases PR122/P and PR123/P with communication module PR120/D-M, the coils YO and YC are controlled directly from contacts K51/YO and K51/YC with maximum voltages of 110-120 VDC and 240-250 VAC.
- Q) The second shunt opening release may be installed as an alternative to the undervoltage release.
- R) The SACE SOR TEST UNIT + opening release (YO) is guaranteed to operate starting at 75% of the Vaux of the opening release itself.  
While the YO power supply contact is closing (short-circuit on terminals 4 and 5), the SACE SOR TEST UNIT is unable to detect the opening coil status.  
Consequently:
- For continuously powered opening coil, the TEST FAILED and ALARM signals will be activated
  - If the coil opening command is of the pulsing type, the TEST FAILED signal may appear at the same time. In this case, the TEST FAILED signal is actually an alarm signal only if it remains lit for more than 20s.
- S) Also available in the version with normally-closed contact
- U) The measuring module PR120/V is always supplied with relay PR123/P.
- V) If fig. 22 is present (second set of auxiliary contacts) simultaneously as relay PR122/P (or PR123/P), the contacts for the zone selectivity in fig. 42 (K51/SZin, K51/SZout, K51/GZin and K51/GZout) are not wired. In addition, the indicator module PR120/K in figures 46 and 47 cannot be supplied.
- W) For the connections between TO toroidal transformer and poles of CB X (or XV) connector, use a shielded 4-pole cable with paired braided wires (BELDEN 9696 paired type), length not exceeding 10m. The shielding will be grounded on CB side.
- X) T3 and T4 poles of X (or XV) connector are used to measure voltage when U>690V. In this case, they must be connected to the secondary winding of the TU voltage transformer (see fig. 44). Ask ABB SACE for applications of the residual current protection with voltages higher than 690V.
- Y) The shielding of the connection cable will be grounded on CB side only. The connection must be made with a two-pole shielded and stranded cable (type BELDEN 3105A) no more than 15m long.
- Z) Short-circuit T5 and T6 if the external neutral current sensor (UI/N)is not connected.

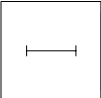
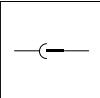
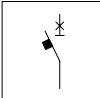
Model	B2342	B2410		Apparatus	<b>Emax</b>	Scale
				Doc. No	<b>1SDH000460R0002</b>	Page No <b>65/74</b>

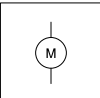
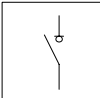
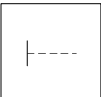
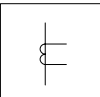
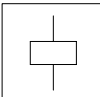
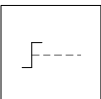
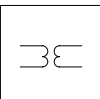
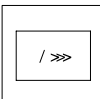
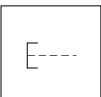
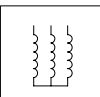
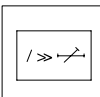
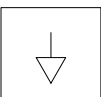
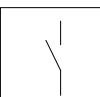
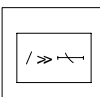
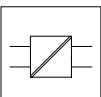
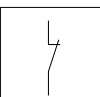
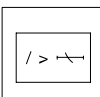
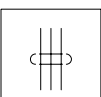
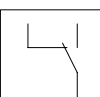
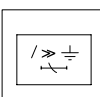
## Circuit diagram symbols (IEC 60617 and CEI 3-14 ... 3-26 Standards)

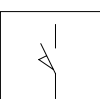
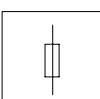
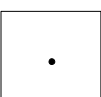
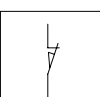
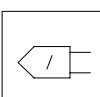
	Shield (may be drawn in any shape)		Terminal		Change-over position contact with momentary circuit breaking (limit contact)
	Time delay		Plug and socket (male and female)		Power isolator with automatic breaking action
	Mechanical or electrical connection		Motor (general symbol)		Switch-disconnector
	Manual mechanical control (general case)		Current transformer		Control coil (general symbol)
	Rotating control		Voltage transformer		Instantaneous overcurrent relay
	Pushbutton control		Winding of three-phase transformer, Star connection		Overcurrent relay with adjustable short time-delay trip
	Equipotentiality		Make contact		Overcurrent relay with inverse short time-delay trip tempo breve inverso
	Galvanically separated converter		Break contact with automatic circuit breaking		Overcurrent relay with inverse long time-delay trip
	Shielded cable conductors (i.e., 3 conductors shown)		Change-over contact		Earth fault overcurrent relay with inverse short time delay
	Conductors or stranded cables (i.e., 3 conductors shown)		Make position contact (limit contact)		Fuse (general symbol)
	Connection of conductors		Break position contact (limit contact)		Current sensor

Model	B2342	B2410		Apparatus	<b>Emax</b>	Scale
				Doc. no.	<b>1SDH000460R0002</b>	Page No <b>66/74</b>

### Circuit diagram - Operating status

Three-pole circuit-breaker with PR121/P, PR122/P or PR123/P electronic release

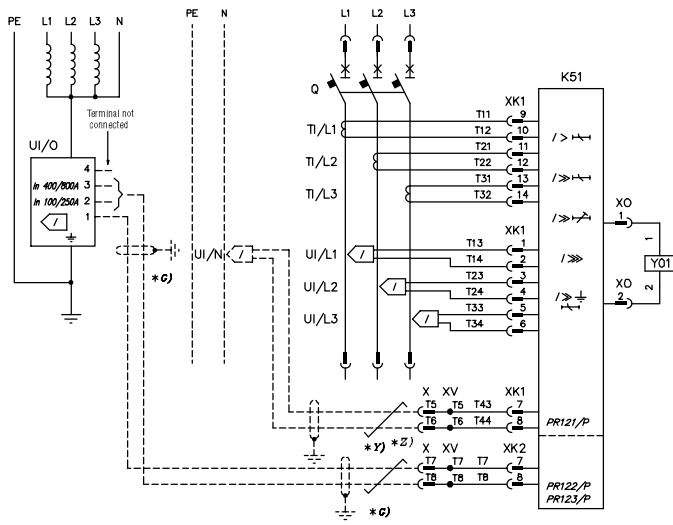

Four-pole circuit-breaker with PR121/P, PR122/P or PR123/P electronic release

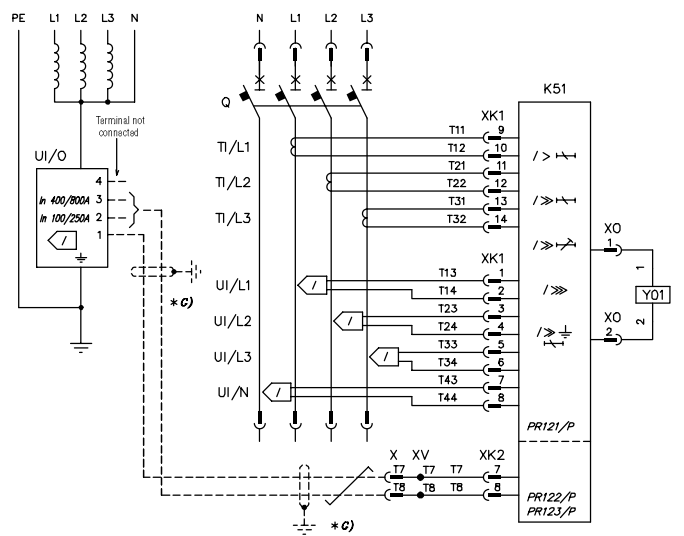

Three-pole circuit-breaker with PR122/P or PR123/P electronic release, residual current protection and  $U_{c} \leq 690V$ .

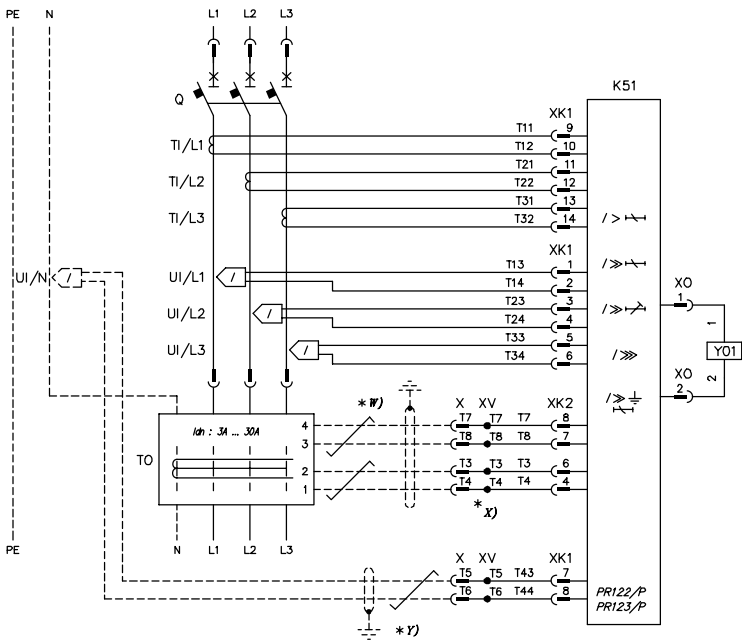

Three- or four-pole switch-disconnector

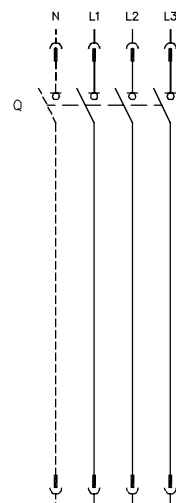

Model	B2342	B2410		Apparatus	<b>Emax</b>	Scale
				Doc. No	<b>1SDH000460R0002</b>	Page No <b>67/74</b>

## Motor operating mechanism, opening, closing and undervoltage releases

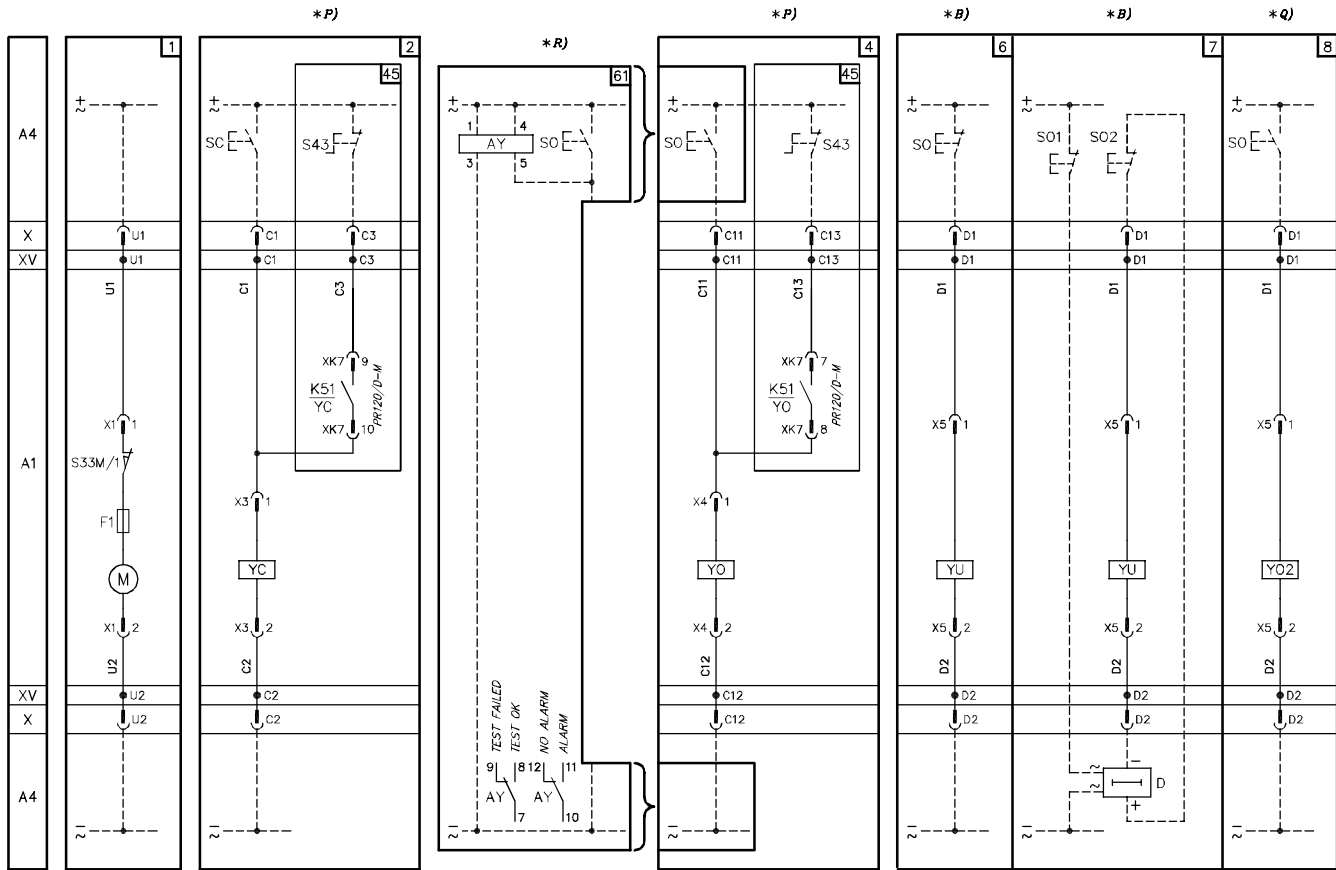

## Signalling contacts

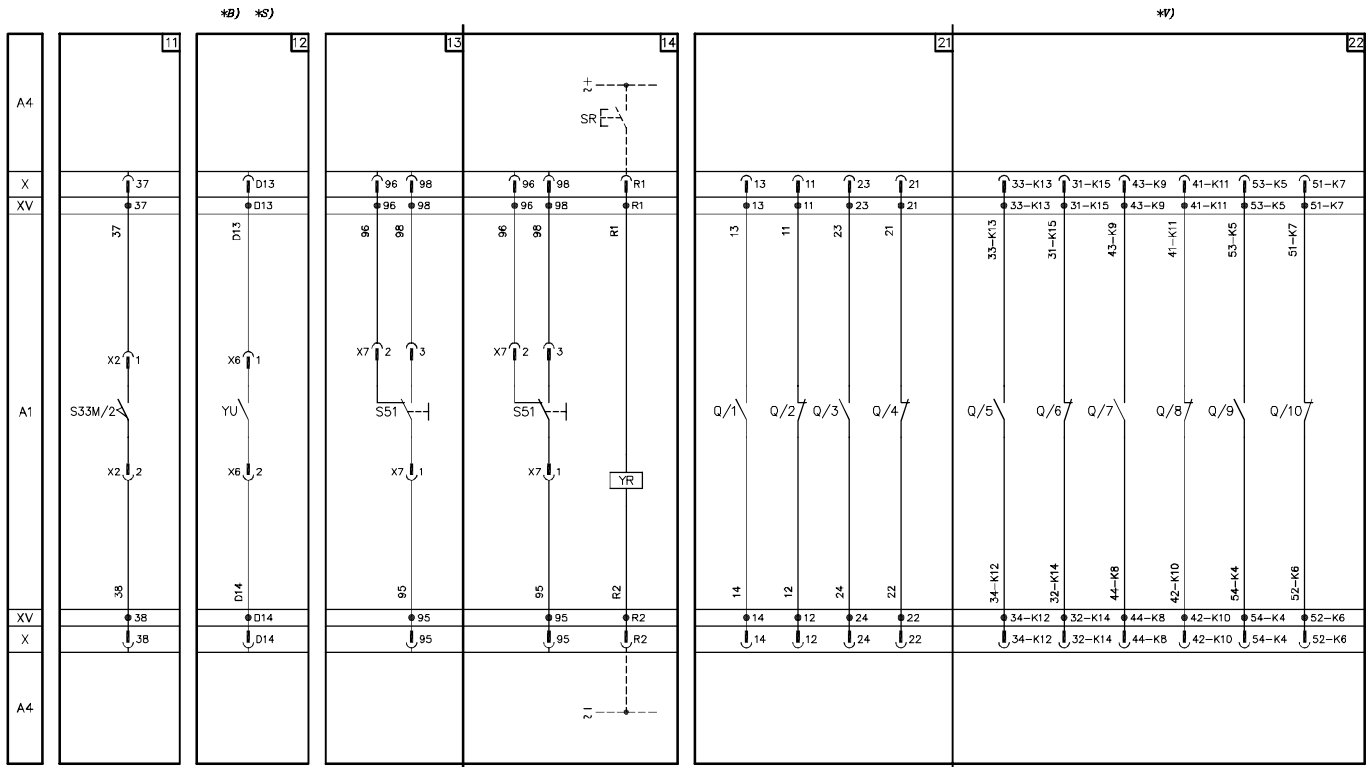

Model	B2342	B2410		Apparatus	<b>Emax</b>	Scale
				Doc. no.	<b>1SDH000460R0002</b>	Page No <b>68/74</b>

# Signalling contacts

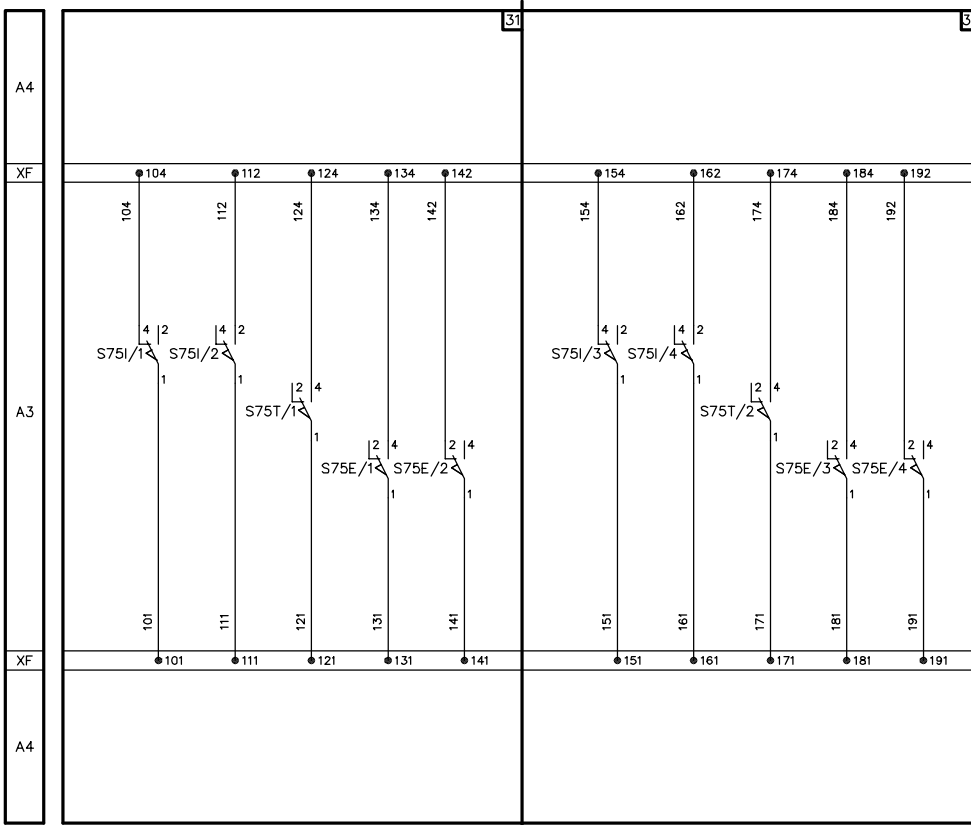
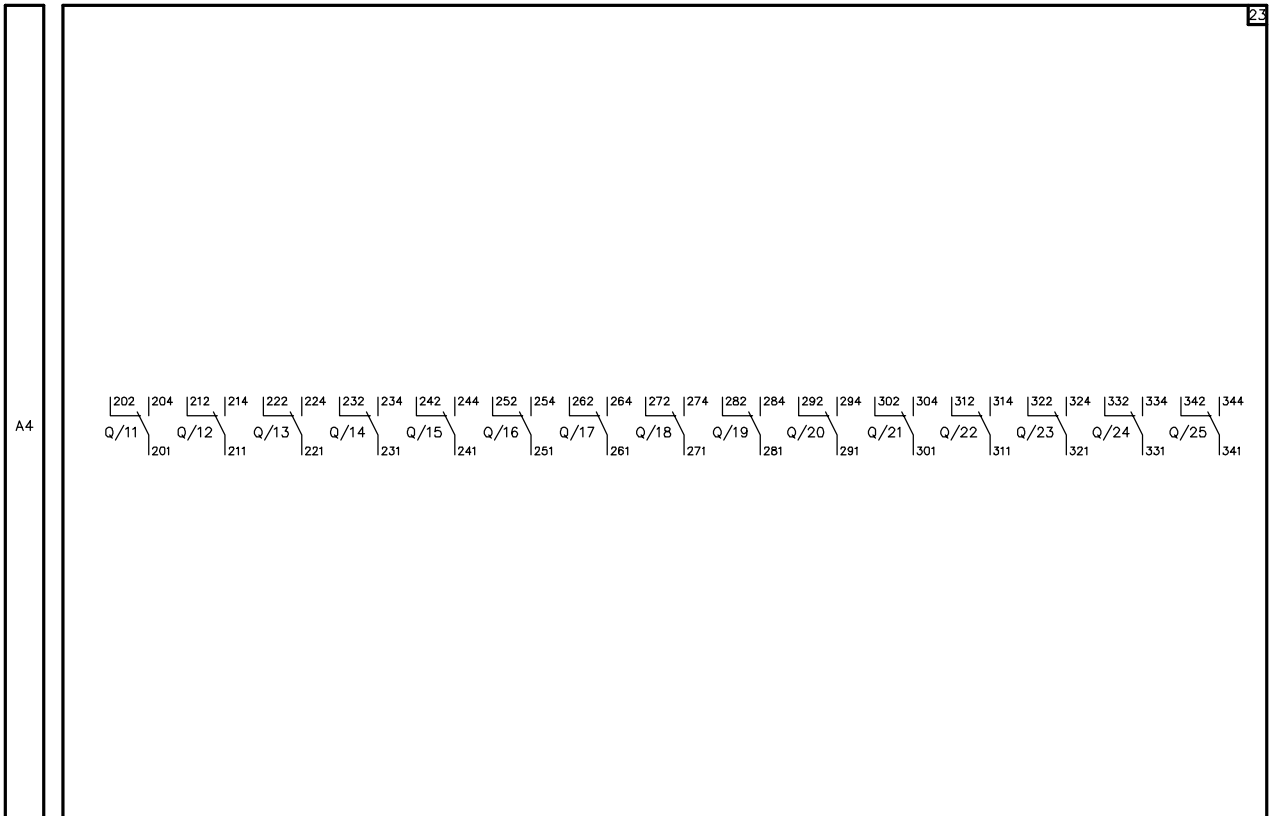

Model	B2342	B2410		Apparatus	<b>Emax</b>	Scale
				Doc. No	<b>1SDH000460R0002</b>	Page No <b>69/74</b>

Auxiliary circuits of the PR121, PR122 and PR123 releases

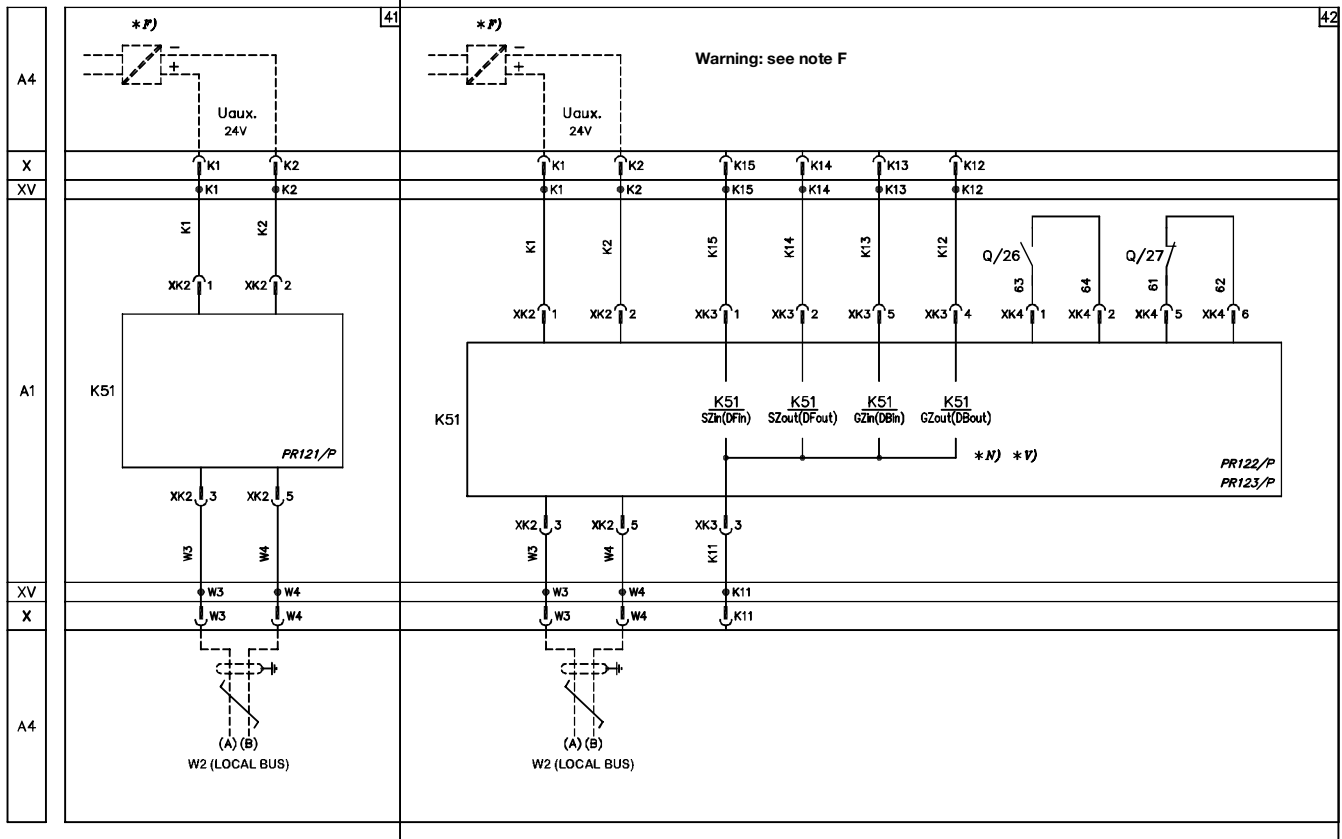

PR120/V measuring module

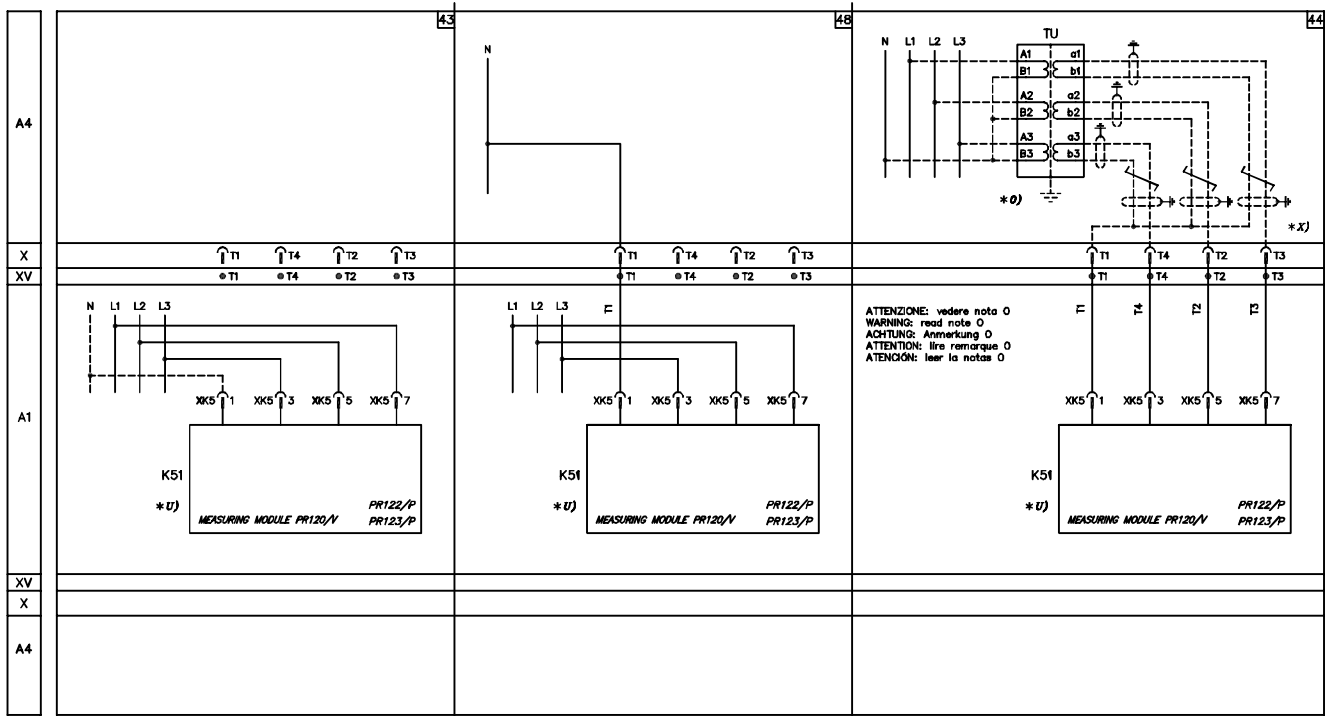

Model	B2342	B2410		Apparatus	<b>Emax</b>	Scale
				Doc. no.	<b>1SDH000460R0002</b>	Page No 70/74

**PR120/D-M communication module**

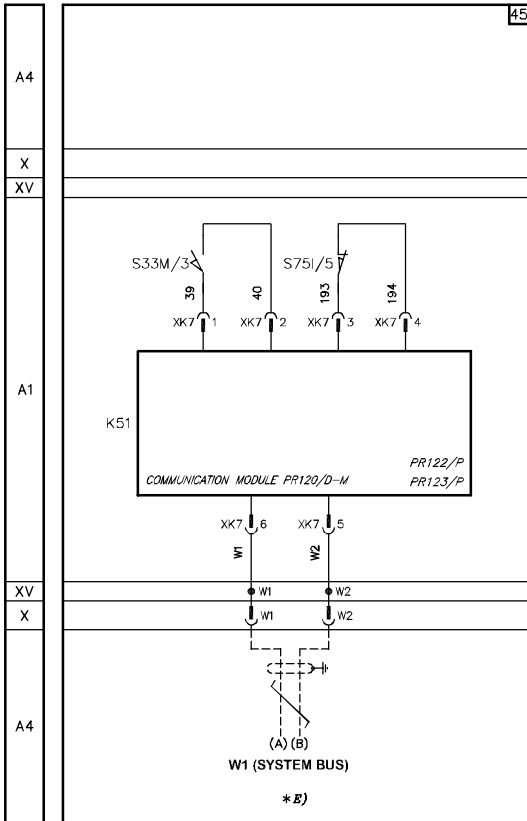

**PR120/K signalling module**

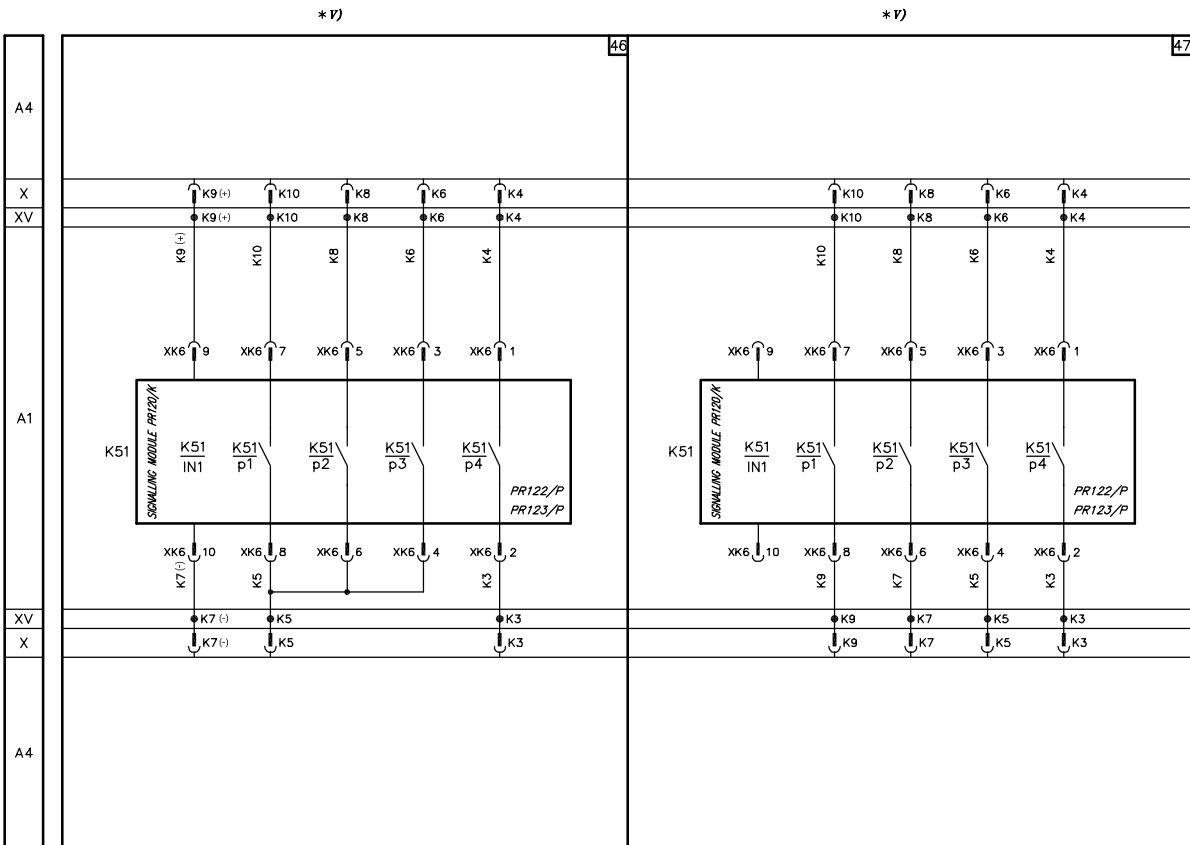

Model	B2342	B2410		Apparatus	<b>Emax</b>	Scale
				Doc. No	<b>1SDH000460R0002</b>	Page No <b>71/74</b>

PR021/K signalling unit

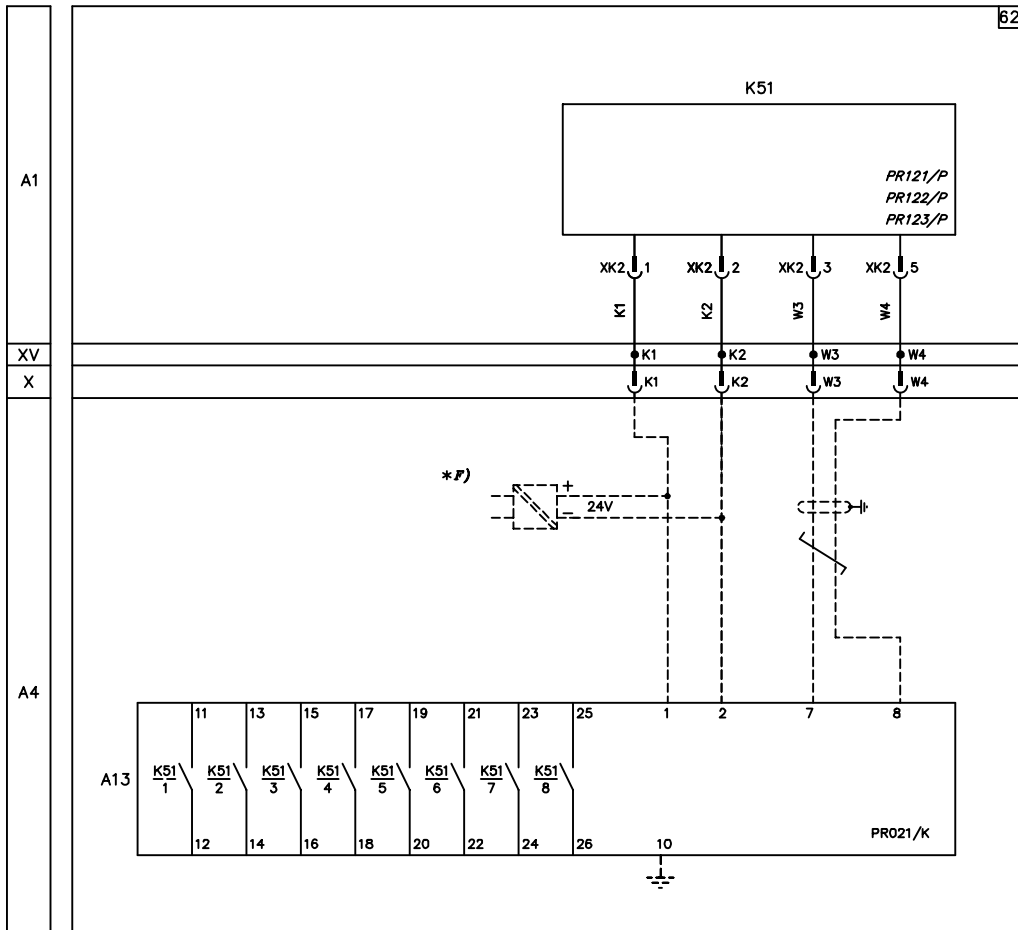

Model	B2342	B2410		Apparatus	<b>Emax</b>	Scale
				Doc. no.	<b>1SDH000460R0002</b>	Page No 72/74







**ABB S.p.A.**  
Via Pescaria, 5  
24123 Bergamo - Italy  
Tel.: +39 035.395.111  
<http://www.abb.com>

*Due to possible developments of standards as well as of materials, the characteristics and dimensions specified in the present catalogue may only be considered binding after confirmation by ABB SACE.*